

রেজিস্টার্ড নং ডি এ-১ “জাতির পিতা বঙ্গবন্ধু শেখ মুজিবুর রহমানের
জন্মশতবার্ষিকী উদ্‌যাপন সফল হোক”



অতিরিক্ত সংখ্যা
কর্তৃপক্ষ কর্তৃক প্রকাশিত

বৃহস্পতিবার ফেব্রুয়ারি ১১, ২০২১

Government of the People's Republic of Bangladesh
Ministry of Housing and Public Works

Notification

Date : 05-11-1426/18-02-2020

S.R.O. No.55-Law/2020.—In exercise of the powers conferred under section 18A of the Building Construction Act, 1952 (Act No. II of 1953) the Government is pleased to make the following Code by repealing the Bangladesh National Building Code, 2006, namely :—

PART I
Chapter 1
Title, Purpose, Scope, Etc

1. **Title and commencement.**—(1) This Code may be called the Bangladesh National Building Code (BNBC) 2020.

(2) It shall come into force at once.

2. **Purpose.**—(1) The purpose of this Code is to establish minimum standards for design, construction, quality of materials, use and occupancy, location and maintenance of all buildings within Bangladesh in order to safeguard, within achievable limits, life, limb, health, property and public welfare.

(2) The installation and use of certain equipment, services and appurtenances related, connected or attached to such buildings are also regulated herein to achieve the same purpose.

(২৫৮৩)
মূল্য : টাকা ১৯৭২.০০

(3) The expressed intent of this Code is to ensure public safety, health and general welfare insofar as they are affected by the construction, alteration, repair, removal, demolition, use or occupancy of buildings, structures or premises, through structural strength, stability, means of egress, safety from fire and other hazards, sanitation, light and ventilation.

3. Scope.—(1) The provisions of this Code shall apply to the design, construction, use or occupancy, alteration, moving, demolition and repair of any building or structure and to any appurtenances installed therein or connected or attached thereto, except such matters as are otherwise provided for in other laws controlling and regulating buildings.

(2) If for any case different sections of this Code provide different specifications for materials, methods of design or construction, or other requirements, the most restrictive specification shall govern.

(3) In case of any conflict between a general requirement and a specific requirement, the specific requirement shall prevail.

(4) Unless otherwise explicitly stated in this Code, all references to part, chapter or section numbers or to provisions not specifically identified by number, shall be construed to refer to such part, chapter, section or provision of this Code.

(5) References made to a section without mentioning a part shall be construed to refer to that section of the part in which the reference is made.

(6) The provisions of any appendix in this Code shall not be mandatory unless they are referred to as such in any section of the Code or they are specifically adopted by any regulation.

(7) Inspection conducted or permission granted for any building or plan of building, under the provisions of this Code, shall not be construed as a warranty of the physical condition of such building or the adequacy of such plan.

(8) Neither the Authority nor any employee thereof shall be liable for damages or any defect or hazardous or illegal condition or inadequacy in such building or plan, nor for any failure of any component of such building which may occur subsequent to such inspection or granting of permission under the provisions of the Code.

4. Existing buildings.—(1) Buildings which are in existence on the date of commencement of this Code may have their use or occupancy continued without undergoing any alteration, abandonment or removal unless in the opinion of the Authority such continued use is hazardous to life and property and provided such use or occupancy was legal on the date of commencement of this Code.

(2) Buildings approved before commencement of this Code and compliant under the repealed Code may continue to be used or occupied unless any deviation is made thereafter or any deterioration has rendered the building unsafe in the opinion of the Authority.

(3) Additions, alterations, modifications or repair to an existing building may be made without requiring the existing building to comply with all the requirements of this Code, provided the additions, alterations, modifications or repairs conform to that required for a new building and such additions or alterations shall not be permitted when the existing building is not in full compliance with the provisions of this Code except when the addition or alteration will result in the existing building or structure being no more hazardous based on life safety, fire safety and sanitation than it was before the addition or alteration was undertaken.

(4) Any building together with the new additions shall not exceed the height, number of storeys and area specified in this Code for new buildings having the relevant occupancy and type of construction.

(5) Non-structural alterations or repairs to an existing building or structure which do not adversely affect any structural member, nor reduce the strength of any part of the building or structure to result in an unsafe condition shall be made with materials and components having the required fire resistance.

(6) Change in use or occupancy in an existing building may be made when such change complies with the requirements of this Code for a new building and provided such change does not render any part or the whole of the affected building or structure any more hazardous based on life safety, fire safety and sanitation than it was before such change was effected.

5. Historic or architecturally valuable buildings.—A building or structure which has been designated by official action as having special historical or archaeological interest, or a building or structure identified by a legally constituted authority as being architecturally valuable, may be undertaken for repairs, alterations and additions necessary for its preservation, restoration, rehabilitation or continued use, provided :

- (a) the proposed repair, alteration or addition to buildings of historical or archaeological significance is approved by the legally constituted authority, such as the Department of Archaeology;
- (b) the proposed repair, alteration or addition to buildings of architectural value does not impair the aesthetic quality and architectural character of such buildings; and
- (c) the restored building or structure will be no more hazardous, if any, based on life safety, fire safety and sanitation than the existing building.

PART I
Chapter 2
Definitions

6. Definitions.—In this Code, unless there is anything repugnant in the subject or context,—

ACCESSORY USE	means any use subordinate to the major use which is normally incidental to the major use.
ALTERATION	means any change, addition or modification in construction such as structural, dimensional, or any removal of any part of a building or any change to or closing of any required means of ingress or egress or a change to the fixtures or equipment or any change in land use or occupancy or use.
APPLICANT	means a person, a firm, a company, a corporation, or a government, semi-government or non-government agency who intends to undertake any work regulated by this Code and who has filed an application to the Building Official for this purpose in a form prescribed in the Code.
APPROVED	means approved by the Authority.
APPROVED PLAN	means the set of plans, designs and specifications of building submitted to the Authority as per provision of this Code and duly approved and sanctioned by the Authority.
ARCHITECT	means a person who has a Bachelor Degree in Architecture and is a member of the Institute of Architects, Bangladesh (IAB).
AUTHORITY	means the Bangladesh Building Regulatory Authority.
AUTHORIZED OFFICER	means BUILDING OFFICIAL.
BASEMENT	means a floor of a building more than 50 percent of which is situated at a depth of 1 m or more below crown of the main entry road.
BUILDING	means any permanent or semi-permanent structure which is constructed or erected for human habitation or for any other purpose and includes but not limited to the foundation, plinth, walls, floors, roofs, stairs, chimneys, fixed platform, verandah, balcony, cornice, projections, extensions, annexes etc. The term building will also include the sanitary, plumbing, electrical, HVAC, appurtenances and all other building service installations which are constructed or erected as an integral part of a building.

BUILDING LINE	means the line up to which the plinth of a building may lawfully extend. Also known as SETBACK LINE.
BUILDING OFFICIAL	means a person who is the jurisdictional administrator of this Code appointed by the Authority.
COMMITTEE	means a Building Construction Committee constituted for any area in the prescribed manner, if necessary.
CONSTRUCT	means ERECT.
CONVERSION	means the change in occupancy or premises to any occupancy or use requiring new occupancy permit.
COVERED AREA	means the ground area above the plinth level which is covered by a building structure. The covered area of a building shall exclude gardens, wells, cornice, sunshade, pergola, septic tank, soak well, unpaved uncovered water body, fountains, drainage structures, boundary wall, gates, porch, uncovered staircase, watchman's cabin, detached pump house, garbage chutes and other uncovered utility structures.
DEVELOPMENT	means carrying out construction of buildings, engineering, mining or other operations in, or over or under land or water. Includes re-development and layout and subdivision of any land. 'To develop' and other grammatical variations shall be interpreted accordingly.
DIPLOMA ARCHITECT	means a person who has a Diploma in Architecture from any recognized Polytechnic or Technical Institute and is a member of the Institution of Diploma Engineers, Bangladesh (IDEB).
DIPLOMA ENGINEER	means a person who has a Diploma in Engineering from any recognized Polytechnic or Technical Institute and is a member of the Institution of Diploma Engineers, Bangladesh (IDEB).
DRAIN	means a conduit or channel for conveying water, sewage, or other waste liquid for subsequent disposal.
DRAINAGE	means the disposal of any liquid with a system meant for this purpose.
ENGINEER	means a person who has a Bachelor Degree in Engineering and is a member of the Institution of Engineers, Bangladesh (IEB).

ERECT	means to erect a new building or re-erect an existing building or to convert a building from one occupancy to another. Also known as CONSTRUCT.
FORMATION LEVEL	means finished ground level of a plot. For hilly areas formation levels shall be the gradient of the plot surface.
GEOTECHNICAL ENGINEER	means engineer with Masters degree in geotechnical engineering having at least 2 (two) years of experience in geotechnical design/construction or graduate in civil engineering/engineering geology having 10 (ten) years of experience in geotechnical design/construction.
ENGINEERING GEOLOGIST	means a person having a postgraduate degree in engineering geology and having 2 years of experience in geotechnical exploration and interpretation.
GOVERNMENT	means the government of the People's Republic of Bangladesh.
GRADE	means the lowest point of elevation of the finished surface of the ground, pavement or footpath within the area between the building and the property line or a line 1.5 m from the building whichever is nearer the building.
HEIGHT OF BUILDING	means the vertical distance from a reference datum to the highest point of the building which includes all building appurtenances like overhead water tank, machine room, communication tower etc. The reference datum shall be the elevation of the nearest footpath or the elevation of the nearest road or street or public way at its centre line, whichever is higher.
HIGH RISE BUILDING	means any building which is more than 10-storey or 33 m high from reference datum. Building appurtenances like overhead water tank, machine room, communication tower etc. will not be considered in determining the height.
OCCUPANCY or USE GROUP	means the purpose for which a building or a part thereof is used or intended to be used.
OCCUPANCY, MAJOR	means the major or principal occupancy of a building or a part thereof which has attached to it subsidiary occupancy or occupancies contingent upon it.

OCCUPIER	means a person paying or liable to pay rent or any portion of rent of a building in respect of which the word is used, or compensation or premium on account of occupation of such building and also a rent-free tenant. Does not include a lodger and the words 'occupancy' and 'occupation' do not refer to the lodger. In such cases, the owner himself or herself is living in his or her own building, he or she shall be deemed to be the occupier thereof.
OWNER OF A BUILDING	means the person, organization or agency at whose expenses the building is constructed or who has the right to transfer the same and includes his or her heirs, assignees and legal representatives, and a mortgagee in possession.
PERMIT	means a written document or certificate issued by the Authority for carrying out a specific activity under the provisions of this Code.
PLANNER	means a person who has a Bachelor or a Postgraduate Degree in Planning and is a member of the Bangladesh Institute of Planners (BIP).
PLINTH AREA	means the elements from the building bases which are exposed above the formation level to form a covered floor area by joining the peripheral points of the elements which are intersected at finished floor plane at the height of plinth level.
PLINTH LEVEL	means height of a covered finished floor which is not more than 1 m above the formation level nor 1.85 m from the crown of adjacent road level.
PLOT	means SITE.
PLUMBING ENGINEER	means an Engineer (Civil/Mechanical) who has experience in the field of plumbing or sanitation.
PUBLIC WAY	means ROAD.
RELIABLE LITERATURE	means RELIABLE REFERENCE.
RELIABLE REFERENCE	means reference materials such as published article, codes, standards or other material judged to be reliable by the professional users and specialists in the subject concerned. This may also be referred to as RELIABLE LITERATURE.

ROAD	means a thoroughfare or public way which has been dedicated or deeded to the public for public use and also known as STREET.
ROAD LINE	means a line defining the side limits of a road.
ROOM HEIGHT	means the clear head room between the finished floor surface and the finished ceiling surface or the underside of the joists or beams, whichever is lower.
SANCTIONED PLAN	means the set of plans, design and specifications of a building submitted to the Authority as per provision of this Code and duly approved and sanctioned by the Authority.
SERVICE ROAD	means a road or lane provided at the rear or side of a plot for service purposes.
SETBACK LINE	means BUILDING LINE.
SITE	means a piece or parcel of land on which a building is intended to be or has already been constructed and also known as PLOT.
SPECIALIST	means a professional who by education, research, practice and experience specializes in a particular branch of a broader discipline and is generally judged to be so by the professional body in the relevant discipline.
STOREY	means the portion of a structure between tops of two successive finished floor surfaces and for the topmost storey, from surface of the finished floor of topmost floor to the top of the roof above.
STOREY, FIRST	means the lowest storey in a building which qualifies as a storey as defined herein; for a building with a basement, it is the storey just above the basements.
STREET	means ROAD.
STREET LEVEL	means the elevation of the centre line of any road or street which a plot fronts.
STREET LINE	means ROAD LINE.
SUPERVISOR, CONSTRUCTION	means an Architect or Engineer or Diploma Architect or Diploma Engineer having experience in supervision of construction works.
UNSAFE BUILDING	means a building which, in the opinion of the Building Official, is structurally unsafe, or insanitary, or lacks proper means of ingress or egress, or which constitutes a hazard to life or property.

PART I
Chapter 3
Abbreviations

7. Abbreviations of names and words.—(1) Names of institutions, organizations and professional societies referred to in this Code are listed below in an alphabetical order, namely :—

ACI	American Concrete Institute; Box 19150, Redford Station, Detroit, MI 48219, USA.
AISC	American Institute of Steel Construction, Inc.; 400 North Michigan Avenue, Chicago, IL 60611, USA.
AISE	Association of Iron and Steel Engineers; Suite 2350, Three Gateway Center, Pittsburgh, PA 15222, USA.
AISI	American Iron and Steel Institute; Suite 300, 1133 15th Street N.W., Washington, DC 20005, USA.
ANSI	American National Standards Institute; 1430 Broadway, New York, NY 10018, USA.
ASHRAE	American Society of Heating, Refrigerating and Air-conditioning Engineers, Inc.; 345 East 47 th Street, New York, NY 10017, USA.
ASME	American Society of Mechanical Engineers; United Engineering Centre, 345 East 47 th Street, New York, NY 10017, USA.
ASTM	American Society for Testing and Materials; 1916 Race Street, Philadelphia, PA 19103, USA.
AWS	American Welding Society; 550 N.W. LeJeune Rd., P.O. Box 351040, Miami, FL 33135, USA.
BIP	Bangladesh Institute of Planners, Planner's Tower (Level-7), 13/A, Bir Uttam C.R. Datta (Sonargaon) Road, Bangla Motor, Dhaka-1000, Bangladesh.
BOCA	Building Officials and Code Administrators International Inc.; 1313 East 60th Street, Chicago, IL 60637, USA.
BPDB	Bangladesh Power Development Board; WAPDA Building, Motijheel Commercial Area, Dhaka-1000, Bangladesh.
BSI	British Standards Institution; 2 Park Street, London W1A 2BS, UK.
BSTI	Bangladesh Standards and Testing Institution; 116A Tejgaon Industrial Area, Dhaka-1208, Bangladesh.
BWDB	Bangladesh Water Development Board; WAPDA Building, Motijheel Commercial Area, Dhaka-1000, Bangladesh.

CDA	Chittagong Development Authority; Station Road, Chittagong, Bangladesh.
CGSM	Canadian General Standards Board; Technical Information Unit, Ottawa, CANADA K1A 1G6.
DOA	Department of Architecture; Sthapatya Bhaban, Shahid Capt. Mansur Ali Sarani, Segunbagicha, Dhaka-1000, Bangladesh.
DPHE	Department of Public Health Engineering; DPHE Bhaban, 14, Shaheed Captain Mansur Ali Sarani, Kakrail, Dhaka-1000, Bangladesh.
EED	Education Engineering Department; Shikkha Bhaban, Dhaka-1000, Bangladesh.
HED	Health Engineering Department; Ministry of Health and Family Welfare, 105-106, Motijheel C/A, Dhaka-1000, Bangladesh.
FM	Factory Manual; Standards Laboratories Department, 1151 Boston Providence Turnpike, Norwood, MA 02062, USA.
FSCD	Fire Service and Civil Defence, Kazi Alauddin Road, Dhaka-1000, Bangladesh.
HBRI	Housing and Building Research Institute, 120/3, Darus-Salam, Mirpur, Dhaka, Bangladesh.
IAB	Institute of Architects Bangladesh, Plot-11, Block-E, Road-7, Sher-e-Bangla Nagar, Agargaon, Dhaka.
IEB	The Institution of Engineers, Bangladesh, Ramna, Dhaka-1000.
IDEB	Institution of Diploma Engineers, Bangladesh, IDEB Bhaban, 160/A, Kakrail VIP Road, Dhaka-1000.
ICBO	International Conference of Building Officials, 5360 South Workman Mill Road, Whittier, CA 90601, USA.
ISO	International Organization for Standardization, 1, Rue de Varembe, Case Postal 56, CH-1211, Genève 20, Switzerland.
ISSMFE	International Society of Soil Mechanics and Foundation Engineering, University Engineering Department, Trumpington St, Cambridge CB21PZ, UK.
KDA	Khulna Development Authority, Shib Bari Crossing, Khulna-9100, Bangladesh.
LGED	Local Government Engineering Department, LGED Bhaban, Sher-e-Bangla Nagar, Agargaon, Dhaka-1207. Bangladesh.

NFPA	National Fire Protection Association, Batterymarch Park, Quincy, MA 02269, USA.
NHA	National Housing Authority, Grihayan Bhaban, 82, Segunbagicha, Dhaka, Bangladesh.
PWD	Public Works Department, Purto Bhaban, Shahid Capt. Mansur Ali Sarani, Segunbagicha; Dhaka-1000, Bangladesh.
RAJUK	Rajdhani Unnayan Kartripakkha, Rajuk Avenue, Motijheel, Dhaka-1000, Bangladesh.
RCSC	Research Council on Structural Connections of the Engineering Foundation, American Institute of Steel Construction (AISC).
RDA	Rajshahi Development Authority, Rajshahi-6203, Bangladesh.
RMA	Rubber Manufacturing Association, 1400 K Street N.W., Washington, DC 20005, USA.
SBCCI	Southern Building Code Congress International, 3617 8th Ave, S. Birmingham, AL 35222, USA.
SMACNA	Sheet Metal and Air Conditioning Contractors' National Association, 8224 Old Courthouse Road, Tysons Corner, Vienna, VA 22180, USA.
SPRI	Single Ply Roofing Institute, 104 Wilmont Road, Suite 201, Deerfield, IL 60015-5195, USA.
UDD	Urban Development Directorate, Ministry of Housing and Public Works, 82, Segunbagicha, Dhaka-1000, Bangladesh.
UL	Underwriters Laboratories Inc., 207 East Ohio Street, Chicago, IL 60611, USA.

(2) The abbreviations of words used in this Code are listed below in an alphabetical order. Abbreviations not explicitly defined herein below shall be construed to have their usual meaning as the context implies.

BDS	Bangladesh Standards; published by the BSTI
BNBC	Bangladesh National Building Code; published by HBRI
BS	British Standard; published by the BSI
CBF	Concentric Braced Frame
CFC	Chlorofluorocarbon

CGI	Corrugated Galvanized Iron
CWPC	Cold Drawn Low Carbon Wire Prestressed Concrete
DCP	Dry Chemical Powder (fire extinguisher)
DDT	Dichlorodiphenyltrichloroethane
DPC	Damp-proof Course
EBF	Eccentric Braced Frame
FAR	Floor Area Ratio
FM	Fineness Modulus
FPA	Flood Prone Area
GI	Galvanized Iron
IBC	International Building Code
IMRF	Intermediate Moment Resisting Frame
IS	Indian Standard; published by the Bureau of Indian Standards
LFD	Load Factor Design
LPG	Liquefied Petroleum Gas
MCSP	Multipurpose Cyclone Shelter Program
OMRF	Ordinary Moment Resisting Frame
RC	Reinforced Concrete
RS	Rolled Steel
RSJ	Rolled Steel Joist
SMRF	Special Moment Resisting Frame
SPA	Surge Prone Area
SRSS	Square Root of the Sum of the Squares
UBC	Uniform Building Code; published by the ICBO
WSD	Working Stress Design
cps	Cycles per second

PART II
Chapter 1
Purpose and Applicability

8. Purpose.—The purpose of this Part is to relate the provisions of the Code to different documents for administration and enforcement of the Code and all legal issues shall be referred to the Building Construction Act, 1952.

9. Applicability.—The requirements of this Code shall be complied within any construction, addition, alteration or repair, use and occupancy, location, maintenance, demolition and removal of a building or structure or any appurtenances connected or attached to it as set forth herein below:

- (a) **Construction:** For construction of a new building, the provisions of this Code shall apply to its design and construction;
- (b) **Removal:** For removal of any portion or the whole of a building, the provisions of this Code shall apply to all parts of the building whether removed or not;
- (c) **Demolition:** For dismantling or demolition of any part or the whole of a building, the provisions of this Code shall apply to any remaining portion and to the work involved in the dismantling or demolition process;
- (d) **Alteration:** For alteration of a building, the provisions of this Code shall apply to the whole building whether existing or new. If the portion of the building to which the alteration is made is completely self-contained with respect to the facilities and safety measures required by this Code, the provisions of this Code shall apply only to that portion and not to the whole building.
- (e) **Maintenance:** Maintenance work shall be undertaken for all new and existing buildings and all parts thereof to continue their compliance with the provisions of this Code. All devices, equipment and safeguards installed as per the requirements of this Code shall be maintained in conformity with the edition of the Code under which installed. The owner of the building or his designated agent shall at all times be responsible for the safe and sanitary maintenance of the building or structure, its means of egress facilities and the safety devices, equipment and services installed therein. The Authorized Officer or his delegated persons as described in relevant documents mentioned in Chapter 2 may cause re-inspection of a building to determine its continued compliance with this Section.

- (f) **Repair:** Application or notice to the Authority administering the Code is not necessary for ordinary repairs to buildings or structures, provided such repairs do not involve the cutting away of any wall or portion thereof, the removal or cutting of any structural or bearing element, the removal or alteration of any required means of egress, or the rearrangement of any parts of a structure affecting the access and exit facilities. All works involving addition to, alteration or change of use of any building or structure shall conform to the requirements set forth in Part 9 of this Code.
- (g) **Land Development:** For development of a land for construction of a building, the provisions of this Code shall apply to the entire development work. For land development purposes the following laws shall also be applicable:
- (i) Building Construction Act 1952;
 - (ii) Private Residential Land Development Rules 2004;
 - (iii) Natural Water Body Protection and Preservation of Open Space and Playground Act 2000.

PART II
Chapter 2
Establishment Of Authority, Etc

10. Establishment of Authority.—The Government may, with the approval of the Ministry of Public Administration, Finance Division and other relevant Ministries and Divisions, by a notification in the official Gazette, establish the Bangladesh Building Regulatory Authority (BBRA).

11. Head office of the Authority.—The head office of the Authority shall be in Dhaka.

12. Constitution of Authority.—(1) The Authority shall consist of the following 5 (five) members, namely:-

- (a) a civil engineer having professional experience of 30 years in design/ construction/teaching/research related to building;
- (b) an architect having professional experience of 30 years in design/ construction/ teaching/ research related to building;
- (c) a planner having professional experience of 30 years in planning/ teaching/research related to building;
- (d) a judge or legal practitioner having professional experience of 30 years in law including the qualification for appointment of a judge of the High Court Division;
- (e) a person having professional experience of 30 years in Bangladesh Civil Service.

(2) The Government shall appoint the members of the Authority and they shall hold office for a period of 3 (three) years.

(3) The Government shall nominate one of the members as the Chairman of the Authority.

13. Responsibilities of the Authority.—The Authority shall—

- (a) be the organization responsible for establishing regulatory framework for building design and construction with efficient and effective compliance mechanism;
- (b) develop building check and control procedure for ensuring high degree of regulatory compliance in planning and the Code requirements and reduce information asymmetry between the end user (building occupant, home owner) and seller (developers, builders);

- (c) streamline and improve transparency through dissemination of information related to built environment including detail land use plan, regulations on safety, water and environmental conservation, health, energy efficiency and urban planning requirements through print and digital media including its website;
- (d) develop an effective licensing system, jointly with the professional bodies by forming a National Council for Licensing of Building Professionals (NCLBP) for conducting examinations for the members of those respective professional bodies;
- (e) update the requirements of building permit and inspection procedure as per this Code;
- (f) require the owner of an existing or under construction high risk building, having major impacts on public safety for inhabitants within and near the building, to carry out review of design and construction by licensed professionals acceptable to the Authority;
- (g) introduce IT based automated procedure for permits and online information system to enable the applicants to track the progress of the permitting process;
- (h) establish an independent quasi-judicial dispute-resolution body that can make binding decisions in disputes between practitioners, developers, stakeholders and permitting authorities on matters related to interpretation of the Code or sufficiency of compliance, which cannot be appealed except to the High Court Division on matters of law;
- (i) recommend punitive and other measures against developers and professionals for violation of the Code and safety measures;
- (j) take measures for updating of the Code in light of research, improved building design and construction technique, availability of new products and technology;
- (k) advise the Government on policy and administration of building regulations including capacity development;
- (l) take up matters from time to time which the Authority deems necessary.

14. Office of the Building Officials, etc.—(1) The Authority shall designate specific geographical jurisdiction as the Office of the Building Official.

(2) The Office of the Building Official shall be established at various local or regional development area or local government levels.

(3) The Authority may, in order to proper functioning of it, subject to the Organogram approved by the Government and having required qualifications, appoint such numbers of Building Officials, technical assistants, inspectors and other employees as required.

(4) The administrative and operational chief of the Code enforcing office shall be designated as the Building Official who shall act on behalf of the Authority.

(5) The Building Official may designate an employee or employees who shall carry out the specified duty and exercise the specified power of the Building Official.

15. Building Construction Committee.—(1) The Building Official shall exercise through a Building Construction Committee comprising four members excluding Building Official.

(2) Building Construction Committee shall consist of one architect, one civil engineer, one town planner and representative from concerned body.

(3) Building Official shall work as ex-officio member-secretary of the Committee.

16. Qualifications of Building Official.—The person to be designated as the Building Official shall be at least an architect, a civil engineer or a town planner in addition to fulfilling any other requirement of the Authority.

17. Administrative jurisdiction of Building Official.—(1) The areas delineated below in Table 2.2.1 shall be under the jurisdiction of the Building Officials located in the offices/authorities mentioned in the right hand column:

Table 2.2.1: Jurisdiction of Building Officials of Designated Offices/Authorities

<u>Sl.</u>	<u>Area</u>	<u>Authority</u>
1	Areas falling under the master plan control of Rajdhani Unnayan Kartipokhkha (RAJUK)	RAJUK
2	Areas falling under the master plan control of Chittagong Development Authority (CDA)	CDA
3	Areas falling under the master plan control of Rajshahi Development Authority (RDA)	RDA
4	Areas falling under the master plan control of Khulna Development Authority (KDA)	KDA
5	Areas falling under the master plan control of any Development Authority to be established in future	Relevant development authority
6	Areas falling under the geographical jurisdiction of any City Corporation where no Development Authority exists	Relevant city corporation
7	Areas falling under the geographical jurisdiction of any Municipality where no Development Authority exists	Relevant municipality

<u>Sl.</u>	<u>Area</u>	<u>Authority</u>
8	Areas not falling under any of the above	Office of The Executive Engineer Public Works Department (PWD)
9	Special areas, if any	To be declared by the government as and when necessary

(2) There may be as many Building Officials as required depending upon the area of jurisdiction, but every Building Official shall be in charge of an independent and well demarcated area.

18. Merging the Jurisdictions under small local bodies.—Small local bodies like Pourashavas, Upazila, Union Parishad, located outside the larger city municipalities and having insufficient funds for individually carrying out the task of the Code enforcing agency may jointly appoint or designate, with the approval of the Authority, a Building Official who shall have a jurisdiction over the combined area of jurisdiction of the concerned local bodies.

19. Restrictions on the Building Official.—(1) The Building Official or any employee designated by him in this behalf shall not in any way, directly or indirectly, be engaged in planning, design, construction, repair, maintenance, modification or alteration of a building, certification of any work or materials, supply of materials, labor, equipment or appliances or any other work regulated by the provisions of this Code.

(2) The Building Official or such designated employee shall not be interested in business, either directly or indirectly, as planner, engineer, architect, builder or supplier or in any other private business transaction or activity within the jurisdiction of the Authority which conflicts with his official duties or with the interest of the Code enforcing agency.

(3) If any Building Official or designated employee violates the restrictions, he shall be liable to punishment as per service rule of the government.

20. Damage Suit.—(1) In the process of discharging the official duties as required and permitted by the Code, the Building Official or any employee shall not be personally liable for any damage that may be caused to any person or property.

(2) Any suit filed against the Building Official or any employee because of an act performed by him in the official discharge of his duties and under the provisions of the Code shall be defended by the legal representative of the Authority until the final decision of the proceedings.

(3) In no case shall the Building Official or any employee be liable for costs in any legal action, suit, or defense proceedings that may be filed in pursuance of the provisions of the Code.

21. Powers and duties of the Building Official.—(1) The Building Official shall be authorized to enforce all the provisions of this Code and for such purposes the Building Official shall have the power of a law enforcing officer.

(2) Applications shall be made in writing to the Building Official for any erection, construction, addition, alteration, modification, repair, improvement, removal, conversion, change of occupancy, and demolition of any building or structure regulated by this Code.

(3) The Building Official shall receive such applications, examine the premises, enforce compliance with this Code and issue permits for the intended work.

(4) All necessary notices and orders to correct illegal or unsafe conditions, to require the specified safeguards during construction, to require adequate access and exit facilities in existing buildings and to ensure compliance with all the requirements of safety, health and general welfare of the public as included in this Code shall be issued by the Building Official.

(5) The Building Official may enter a building or premises at reasonable times to inspect or to perform the duties imposed by this Code if:

- (a) it is necessary to make an inspection to enforce the provisions of this Code; or
- (b) he has reasonable cause to believe that a condition contrary to or in violation of this Code exists making the building or the premises unsafe, hazardous or dangerous.

(6) If the building or premises is occupied, the Building Official shall present credentials to the occupant and request entry.

(7) If the building or premises is unoccupied, the Building Official shall first make a reasonable effort to locate the owner or any other person having charge or control of the building or premises and request entry.

(8) If entry into the building or premises is refused or the owner of the unoccupied building or premises cannot be located, the Building Official shall secure entry as provided by the law.

(9) The Building Official or an employee designated by him in this behalf shall inspect all construction or work for which a permit is required or he may accept reports of inspection by a licensed engineer, architect or planner provided he satisfies the requirements of Table 2.3.4 and may disapprove the report showing specific reason for disapproval.

(10) The work or construction to be inspected shall remain accessible and exposed for inspection purposes until the approval is obtained.

(11) All reports of inspection shall be in writing and certified by the Building Official or the licensed engineer or the architect making the inspection.

(12) Approval of work or construction as a result of such inspection shall not be interpreted to be an approval of a violation of the provisions of this Code or of other law.

(13) The Building Official may require survey of the site and adjoining areas to verify that the structure is located in accordance with the approved plans.

(14) The Building Official or such designated employee shall carry proper identification when inspecting structure or premises in the performance of duties under the provision of this Code.

(15) The Building Official may issue an order for immediate discontinuation of a work and cancellation of a previous permit for such work at any stage if:

- (a) any work is being done contrary to the provision of this Code or other pertinent laws; or
- (b) it is determined by him that the construction is not proceeding according to the approved plan, dangerous or unsafe.

(16) In such cases the Building Official shall notify the owner in writing of such an order by showing the reason for the order, and the conditions under which the cited work will be permitted to resume.

(17) When there is insufficient evidence of compliance with the provisions of this Code, a Building Official shall have the authority to require test as evidence of compliance to be made at no expense to the office of the Building Officials and the test shall be performed by an agency approved by the Building Official.

(18) Any person who shall continue any work after having been served with a stop work order, except such work as that person is directed to perform to remove a violation or unsafe condition, shall be subject to penalties as prescribed by law.

(19) The Building Official may order the current uses of a building discontinued and the building or portion thereof vacated by serving a notice on any person if the Building Official determines that the building or structure or equipment therein regulated by this Code is being used contrary to the provisions of this Code, such person shall discontinue the use within the time prescribed by the Building Official after receipt of such notice to make the structure, or portion thereof, comply with the requirements of this Code.

(20) The Building Official shall maintain records of all applications and drawings received, permits and orders issued, inspections made and reports prepared and submitted by other recognized agencies.

(21) Copies of all relevant papers and documents for enforcement of the Code shall be preserved by the Building Official. All such records shall be kept open to public inspection at all suitable times.

(22) The Building Official may engage, subject to the approval of the Authority, an expert or a panel of experts for opinion on unusual technical issues that may arise in administering the provisions of the Code.

22. Board of Appeal.—(1) The Authority may, with the approval of the Government, constitute a Board of Appeal to hear and decide appeals of orders, decisions or determinations made by the Building Officials related to the application and interpretation of this Code.

(2) The Board of Appeal shall consist of members appointed by the Authority who are noted for their educations and experience in the relevant field of building construction and whose term of office shall be as decided by the Authority.

(3) The Board of Appeal shall provide reasonable interpretation of the provisions of this Code and determine the suitability of alternative materials or methods of design or construction.

(4) The Board of Appeal shall, with the approval of the Government, adopt rules of procedure for conducting its business, and shall communicate all decisions and findings in writing to the appellant with a copy to the Building Official.

(5) The Board of Appeal shall have no discretion for interpretation of the administrative provisions contained in Part 2 of this Code nor shall be empowered to waive any requirement of this Code.

23. Requirement of certification of work.—Any planning, design, supervision of construction, repair, maintenance, modification and alteration of buildings, or any other work regulated by the Code shall be certified by a licensed engineer, architect or planner for its compliance with the provisions of the Code as per Tables 2.3.3 and 2.3.4.

24. Limits of professional conduct.—(1) Any licensed architect, engineer or planner may take assistance from fellow professionals who are not licensed but is member of professional bodies and who shall work under his direct control and he shall be allowed to plan, design and supervise construction, repair, maintenance, alteration and modification of buildings or structures regulated by this Code provided the licensed professional certify compliance of the work with the provisions of the Code.

(2) In case of any violation of the Code the licensed professionals who shall certify will be liable for action through professional bodies and such person may provide any such certificate as long as his or her services are recognized by the Building Official and such recognition is not withdrawn under the provisions of this Code.

25. Violation and penalties.—Any person, firm, corporation or government department or agency who as owner of the property erects, constructs, enlarges, alters, repairs, moves, improves, removes, converts, demolishes, equips, uses, occupies or maintains any building or structure or cause or permit the same to be done in violation of this Code shall be guilty of an offence and the Authority shall take legal action against such offenders as prescribed by law.

Explanation.—For the purpose of this provisions the term “owner” shall include any developer who by appointment, contract or lease is responsible for such activities.

26. Professional violation.—(1) The engineer, architect or planner responsible for design, supervision or certification of any construction or other work of a building or structure shall ensure compliance of such work with the provisions of this Code.

(2) Any violation of the Code or any other professional misconduct insofar as implementation of the provisions of this Code is concerned including making false statements or issuing false certificates or any incidence of proven professional incapability shall be recommended to the respective professional bodies for necessary disciplinary measure including withdrawal of recognition or registration.

27. Obligation of offender.—A person shall not be relieved from the duty of carrying out the requirements or obligations imposed on him or her by virtue of the provisions of this Code even if such person is convicted for an offence under the provisions of this Section.

28. Conviction no bar to further prosecution.—If a person is convicted under the provisions of this Code for failing to comply with any of its requirements or obligations such conviction shall not act as a bar for further prosecution for any subsequent failure on the part of such person to comply.

PART II
Chapter 3
Permits and Inspections

3.1 Permits

No building or structure regulated by this Code shall be erected, constructed, enlarged, altered, repaired, moved, improved, removed, converted or demolished without obtaining permit for each such work from the Building official.

Exceptions:

The following works are exempted from the requirement of a permit unless they do not otherwise violate the provisions of this Code, for the said work or any other adjacent property, regarding general building requirements, structural stability and fire safety requirements of this Code:

- (a) Opening or closing of a window or a door or a ventilator;
- (b) Providing internal doors;
- (c) Providing partitions;
- (d) Providing false ceiling;
- (e) Gardening;
- (f) Painting;
- (g) Plastering and patch work;
- (h) Re-flooring;
- (i) Construction of sunshades on one's own land;
- (j) Re-erection of portion of buildings damaged by earthquake or cyclone or other natural calamities, to the extent and specification as existed prior to such damage; and
- (k) Solid boundary walls less than 1.5 m and open boundary wall less than 2.75 m in height.

3.2 Types of Permit

Building permit shall comprise of the following 4 (four) stages:

- (a) Land use certificate.
- (b) Large and specialized project permit.
- (c) Building permit.
- (d) Occupancy certificate.

Permit of all or any of the above may be necessary for a particular area/city/town/municipality. Requirement in this regard shall be incorporated in the building construction byelaws/rules/regulations valid for that particular area/city/town/municipality.

3.2.1 Validity of Permits from the Date of Issuance

The validity of permits for different purposes from the date of issuance shall be as follows:

- | | |
|--|--|
| (a) Land use certificate | 24 months |
| (b) Large and specialized project permit | 24 months |
| (c) Building permit | 36 months (unless construction up-to plinth level is done) |
| (d) Occupation certificate | Perpetual (unless any change in use and physical properties) |

3.2.2 Permits Obtained Prior to Adoption of Code

If permit for a building or structure or a work regulated by this Code is obtained before adoption of this Code and the building or structure or work for which the permit is obtained is not completed within three years from the date of issuance of such permit, the said permit shall be deemed to have lapsed and fresh permit shall be necessary to proceed further with the work in accordance with the provisions of this Code.

3.3 Constitution of Building Permit Committees

3.3.1 As per the provisions laid out in the Building Construction Act the government may constitute various committees to examine and scrutinize applications mentioned in Clause 3.2 above and approve or refuse permits thereby.

3.3.2 Each committee will have specific Terms of Reference and Work Procedure.

3.4 Application For Permit

3.4.1 Any person who intends to undertake any work on a building or structure or land regulated by this Code shall file application in writing on the prescribed form furnished by the Building official for that purpose.

3.4.2 Application for permit for any work under the provisions of this Code shall be accompanied by necessary documents, drawings, certificates, clearances and other relevant information as required by the Building Official for that particular city/town/municipality/jurisdiction area etc.

3.4.3 The drawings shall have any of the sizes specified in the Table 2.3.1:

Table 2.3.1: Drawing Sizes for Permit Applications

Notation (ISO Standard)	Size (mm)
A 0	841 x 1189
A 1	594 x 841
A 2	420 x 594
A 3	297 x 420
A 4	210 x 297

3.4.4 Operation and Maintenance of Utility Services

The government may undertake works for operation, maintenance, development or execution of any of the following utility services without requiring obtaining permit from the Building Official.

- (a) Railways
- (b) National Highways
- (c) National Waterways
- (d) National Gas grid
- (e) National Power grid
- (f) Major Ports
- (g) Airways and Aerodromes
- (h) Telecommunications
- (i) Electronic Broadcasting Services
- (j) Any other services which the Government may, by notification, declare to be a service for the purpose of this Section if the Government is of the opinion that the operation, maintenance, development or execution of such service is essential to the community.

Buildings constructed in connection with these services shall conform to the specifications of this Code.

3.5 Disposal of Application

3.5.1 Subject to the submission of correct and complete application for the permits included in Sec 3.2 above, should be disposed by the Building Official within the time limit as shown in Table 2.3.2:

Table 2.3.2: Time Limit for Disposal of Application for Permits

Type of Permit	Maximum time allowed for disposal (approval or refusal by the Building official)
Land use certificate	15 days
Large and Specialized Project permit	45 days
Building permit	45 days
Occupancy certificate	15 days

3.5.2 The Building Official shall notify the applicant according to above table as the case may be either approval or refusal of the permit for any work. If the Building Official does not notify the applicant of such approval or refusal within this specified period, the application shall be deemed to have been approved provided the fact is brought to the notice of the Building Official. Such approval shall not be interpreted to authorize any person to do anything in contravention of or against the terms of lease or titles of the land or against any other regulations, bylaws or ordinance operating on the site of the work or any of the provisions of this Code.

3.5.3 Refusal of permit shall be accompanied with reason and the Building Official shall quote the relevant sections of this Code which the application/drawings/submissions contravene. The applicant may correct or remove such reasons and reapply for permit with any fee if applicable. The Building Official shall scrutinize the re-submitted application and if there be no further objection it shall be approved and permit issued.

3.6 Preparation And Signing of Drawings

3.6.1 All drawings submitted for approval shall be prepared and signed by registered professionals as specified in Table 2.3.4, which shall be considered as equivalent to certifying that the drawing on which the signature appears conforms to all the requirements of this Code. Registered Professionals shall put his or her signature with date on the title box of the drawing along with his name, address, professional society membership number, registration number and any other information required by the concerned Building Official.

3.6.2 The drawings shall also contain the signature, name and address of the owner.

3.6.3 Subject to the classification and use of buildings, all drawings for approval and execution shall be prepared and signed by the registered professionals as per building category specified in Tables 2.3.3 and 2.3.4 corresponding to relevant work.

Table 2.3.3: Building Classification Based on Height, Floor Area and Occupancy Type

Building Category	Height of Building	Floor Area	Type of Occupancy
I	Up to 2 Stories or 8 m height (without basement) applicable only for areas beyond the jurisdiction of Development Authority, City Corporation and Pourashava	Up to 250 m ²	A (A1-A2)
II	Up to 5 Stories (with or without basement)	Up to 1000 m ²	A (A1-A5)
III	Up to 10 stories or 33 m height for engineering design and supervision and any height for land survey, sub-soil investigation and architectural design	Up to 7500 m ²	A, B, C, E1, E2, F1, F2 and H1
IV	Any height	Any Size	All Occupancy Type

Table 2.3.4: Eligible Registered/Licensed Professionals for Signing of Design, Drawings, Reports and Documents

Types of Work	Registered Professional	Minimum Experience Requirement in Years for Building Category			
		I	II	III	IV
Land Survey	Civil Engineer	NA	NR	NR	NR
	Planner		NR	NR	NR
	Diploma Engineer (Civil)		3	3	3
	Certified Surveyor		3	3	3
Soil Investigation Report	Geotechnical Engineer having experience in soil investigation and soil test report analysis	NA	NR	NR	NR
	Civil Engineer having experience in soil investigation and soil test report analysis	NA	2	2	5

Types of Work	Registered Professional	Minimum Experience Requirement in Years for Building Category			
		I	II	III	IV
Architectural Design	Architect	NA	NR	2	8
	Civil Engineer	NA	NR	NE	NE
	Diploma Architect	NA	5	NE	NE
Structural Design	Civil Engineer with experience in structural design or PEng.	NA	2	4	8 (having 5 years in Structural design)
	Civil Engineer with M.S in Structural Engineering	NA	1	3	8 (having 4 years in Structural design)
Plumbing Design	Plumbing Engineer	NA	NR	4	8
	Architect	NA	NR	NE	
	Diploma Engineer (Civil)	NA	3	NE	NE
Mechanical (HVAC/Vertical Transportation) Design	Mechanical Engineer	NA	2	4	8
Electrical Design	Electrical Engineer	NA	2	4	8
	Diploma Engineer (Electrical)	NA	3	NE	NE
Construction Supervision	Architect/Engineer in their respective field or PEng.	NA	2	4	8
	Diploma Architect/Diploma Engineer in their respective field	NA	2	4	20*
Building Demolition	Civil Engineer	NA	NR	2	8
	Diploma Engineer (Civil)	NA	2	NE	NE
Completion Report	Architect and Engineer with experience in their respective field	NA	2	4	8

Note: NA: Not Applicable, NE: Not Eligible, NR: Not Required.

*Shall be countersigned by registered/licensed Architect/Engineer eligible for Building Category IV.

3.7 Fees

All applications shall be accompanied by fees as specified by the authority from time to time without which the application shall be deemed to be incomplete.

3.8 Responsibilities and Duties of The Owner

3.8.1 General

The owner of a building or structure regulated by the provisions of this Code shall be responsible for carrying out the work in conformity with the provisions of this Code. Granting of permission for any work or approval of plans or inspection by the Building Official or any of the deputies shall not relieve the owner from such responsibility.

3.8.2 Employment of Technical Personnel

Design, execution and supervision work of any building shall be carried out by authorized Registered Professionals as outlined in Table 2.3.4. Owner shall take the services of as many professionals as required according to type and size of the work.

3.8.3 Right of Entry

The owner shall allow the Building Officials to enter the site for the purpose of enforcing the Code as required by the provision of Sec 2.9.6 and for the purpose of inspection as provided in Section 3.10 below.

3.8.4 Permits from Other Agencies

The owner shall obtain permit as may be applicable from other concerned agencies relating to building, zoning, grades, sewers, water mains, plumbing, fire safety, signs, blasting, street occupancy, gas, electricity, highways and all other permits required in connection with the proposed work.

3.8.5 Information on Progressive Work

The owner shall inform the Building Official about attainment of construction work of different stages as required by the Building Official in prescribed form.

3.8.6 Safety Measures

The owner shall take proper safety measures in and around the construction site.

3.8.7 Notice of Completion

The owner shall notify the Building Official the completion of the work for which permit was granted in prescribed form. The work shall not be accepted as complete, without a certification from the Building Official.

3.8.8 Documents at Site

The owner shall preserve at the site a copy of all permits issued and all drawings approved by the Building Official. Results of tests carried out for determination of conformity of the work with the provisions of this Code shall also be preserved and made available for inspection during execution of the work.

3.8.9 Live Load Posted

Where the live loads for which each floor or portion thereof of a commercial or industrial building is or has been designed to exceed 2.4 kN/m², such design live loads shall be conspicuously posted by the owner in that part of each storey in which they apply, using durable signs. It shall be unlawful to remove or deface such notices.

3.9 Responsibilities and Duties of Technical Personnel

3.9.1 To qualify as Architect, Engineer, Construction Supervisor (Architect or Engineer or Diploma Architect or Diploma Engineer) of any building works one shall have membership of the respective professional body in the country. In addition they shall have to qualify as registered professional through an examination (written/oral) to be conducted by their respective professional body as per requirement of this Code.

3.9.2 Only technical professionals qualified under Sec 3.9.1 shall design, execute and supervise any building which is subjected to approval granted under this Code.

3.9.3 Any lapses on the part of the technical personnel in delivering the requirements of the Code shall call for punitive actions against him/her in the proper forum.

3.10 Inspection

All works relating to a building or structure regulated by the provisions of this Code for which permits are required shall be subject to inspection by the Building Official. Modalities and frequency of such inspections shall conform to the requirements put forward by the approving authority.

3.11 Unsafe Buildings

3.11.1 General

All buildings considered to constitute danger to public safety or property shall be declared unsafe and shall be repaired or demolished as directed by the Building Official.

3.11.2 Examination

The Building Official shall examine or cause examination of every building reported to pose threat to safety or be damaged by wear and tear or accident and shall make a written record of such examination.

3.11.3 Notification

If a building is found to be unsafe, the Building Official shall notify the owner of the building and specify the defects thereof. The notice shall require the owner within a stated time either to complete the required repair or improvement or demolish and remove the building or portion thereof.

3.11.4 Disregard of Notice

In case the owner fails, neglects or refuses to carry out the repair or improvement of an unsafe building or portion thereof as specified in the notice, the Building Official shall cause the danger to be removed either by demolition or repair of the building or portion thereof or otherwise, the cost of which shall be borne by the owner.

3.11.5 Cases of Emergency

If the Building Official considers that an unsafe building or structure constitute imminent danger to human life or health or public property, the Building Official shall at once or with a notice as may be possible promptly cause such building or structure or portion thereof to be rendered safe or removed. In such cases the decision of the Building Official shall be final and binding and he or any of his assigned deputies may at once enter such structure or land on which it stands or the abutting land or structure, with such assistance from and at such cost to the owner as may be deemed necessary. The Building Official may also get the adjacent structures vacated and protect the public by an appropriate fence or such other means as may be necessary.

3.12 Demolition of Buildings

If a building or structure is to be demolished, the owner shall notify all agencies providing utility services to the building. Such agencies shall remove all their appurtenances and equipment and dismantle all service connections to ensure a safe condition. The Building Official shall not grant any permit for demolition of a building until a release is obtained from the utility services stating that all service connections have been removed in the proper manner. The demolition work shall be done under the supervision of demolition expert as per provisions of Table 2.3.4.

3.13 Validity of This Code

3.13.1 Partial Invalidity

In case any provision of this Code is held to be illegal or void, this shall have no effect on the validity of any other provision of the Code nor on the same provision in different cases nor on the Code as a whole, and they shall remain effective.

3.13.2 Invalidity of Existing Buildings

If any provision of this Code is held to be illegal or void by the Authority as applied to an existing building or structure, validity of that provision or any other provision of the Code in its application to buildings hereafter erected shall not be affected.

3.14 Architectural and Environmental Control

3.14.1 Besides enforcing the provisions of this Code for normal buildings and structures, the Building Official shall, for special structures such as those listed in Sec 3.14.2 below, also examine the aesthetics and environmental issues vis-a-vis the existing structures and the characteristics of the area, and exercise architectural and environmental control in accordance with the provisions of this Section.

3.14.2 Special structures for which architectural and environmental control shall be exerted by the Building Official shall include:

- (a) major public building complexes
- (b) buildings in the vicinity of monuments and major sculptures
- (c) buildings and structures near existing structures identified to be architecturally valuable.
- (d) buildings and structures near historic buildings or in a area of historical or archaeological significance.
- (e) buildings near any structures that represents the special characteristics of an area
- (f) any proposed building or structure that represents the special characteristics or forms part of a larger master plan of an area, and
- (g) any development that may have an effect on the environment or characteristics of an area.

3.14.3 The Authority shall, for the purpose of exercising the architectural and environmental control and for identifying existing structures having architectural value, appoint a standing committee comprising noted experts from the fields of Architecture, Archeology, Planning, History, Art, Literature, Engineering or any other discipline which may be deemed relevant. The committee shall examine the aesthetic quality of the proposed building, structure or development and the effect it may have on the characteristics and environment of the area in order to ensure aesthetic continuance of the new structure with the existing ones and aesthetic blending of the new structure with the surroundings. The committee may require additional drawings and information for a detailed study of the proposed work. The committee for the purpose of arriving at their decision, may at their discretion depending on the magnitude of the project and impact it may have on public life, hear the architect of the proposed work who may wish to explain the various features of the project, note comments of other experts in the relevant disciplines, or in exceptional circumstances, institute a public hearing to assess public reaction to the project.

3.14.4 The committee may approve the proposed work, recommend changes in the scheme, or disapprove the scheme, for reasons of aesthetics and environmental control.

3.14.5 The Building Official shall not issue permit for undertaking the proposed work until obtaining a report from the standing committee stating that the intended work is acceptable in respect of its effect on the environment, landscape, architectural characteristics, historical feature or any other aesthetical quality of the locality, area or landscape concerned.

3.15 Making Implementation Procedures

Detailed byelaws and implementation procedure to enforce the provisions of this Code shall be prepared and published by the relevant authorities.

3.16 List of Related Appendices

Appendix A	Form for Application of Land Use/Development/Building Permit
Appendix B	Form for Certificate of Supervision
Appendix C	Form for Sanction or Refusal of Land Use/Development/Building Permit
Appendix D	Form for Appeal against Refusal of any Permit
Appendix E	Form for Completion Certificate
Appendix F	Form for Occupancy Certificate

PART II
Appendix A

(Position and Address of the Building Official)
Form for Land Use/Development/Building Permit
First Application to Develop, Erect, Demolish or to Make
Alteration in any Part of the Building

Type of intended work: Develop Erect Demolish Alter

(Check one)

Name of the owner: _____

Contact address: _____

Post code: _____

Telephone no: _____

Name, address and qualification of the engineer, architect or planner involved in the proposed work:

For planning: _____

For architectural design: _____

For structural design: _____

For civil works design: _____

For other services design: _____

Address of the site

Plot number: _____ Holding number: _____

Dag/Khatian number: _____ Mouza/Block/Sector: _____

Street name: _____ Municipal ward number: _____

Documents enclosed along with this form:

	Name of document	Number of sheets	Number of copies
1.	Key plan	_____	_____
2.	Site plan	_____	_____
3.	Subdivision/layout plan	_____	_____
4.	Building plan	_____	_____
5.	Services plan	_____	_____
6.	Specifications	_____	_____
7.	Ownership title	_____	_____

Date

Signature of the owner

For use of the Building Official. Do not write anything below this line.

Reference number: _____ Date: _____

(To be referred to in all subsequent correspondences)

Received by: _____

PART II
Appendix B

Form for Certificate of Supervision

Reference number: _____

Address of the site:

Plot number: _____ Holding number: _____

Street name: _____

Municipal ward number: _____

Type of intended work (Check one) :

Develop Erect Demolish Alter

Name of the owner: _____

Contact address: _____

Post code: _____

Telephone no: _____

I hereby certify that the building for which the location, the type of work, and the name and address of owner appear above will be supervised by me as per the provisions of the Bangladesh National Building Code.

Signature of the engineer, architect, planner or supervisor

Name of the engineer, architect, planner or supervisor

Address

Qualification

Date

**PART II
Appendix C****(Position and Address of the Building Official)
Form for Sanction or Refusal of Land Use/Development/Building Permit**

Reference number: _____

In response to your application whose reference number appears above, I hereby inform that the documents submitted along with your application have been (check as appropriate)

Approved for implementation by the Authority

Refused by the Authority for violation of the following provisions of the Bangladesh National Building Code:

(List of the sections violated)

Signature of the Officer_____
Permit number_____
Name of the Officer_____
Official stamp_____
Designation_____
Date

PART II
Appendix D

Form for Appeal against Refusal of any Permit

Reference number: _____

The application whose reference number appears above has been refused by the Authority. I hereby appeal against the refusal for the following reasons.

(List of the justifications for the appeal)

Date

Signature of the owner

For use of the Building Official. Do not write anything below this line.

Received by: _____

Date: _____

**PART II
Appendix E****Form for Completion Certificate**

Reference number: _____

Permit number: _____

Address of the site:

Plot number: _____ Holding number: _____

Dag/Khatian number: _____ Mouza/Block/Sector: _____

Street name: _____ Municipal ward number: _____

Documents enclosed along with this form:

Type of work (Check one)

Develop Erect Demolish Alter

Name of the owner: _____

Contact address: _____

Post code: _____

Telephone No: _____

I hereby certify that the work having the above mentioned detailed particulars has been supervised by me and completed in accordance with the plan and design approved by the permit number cited and the provisions of the Bangladesh National Building Code.

Signature of the engineer, architect, planner or supervisor_____
Name of the engineer, architect, planner or supervisor_____
Address_____
Qualification_____
Signature of the owner_____
Date_____
Date**This Part to be completed by the Building Official.**

The work identified by the reference number and permit number at the top of the form is hereby accepted as complete in accordance with the approved plan and design.

Signature of the Officer_____
Name of the Officer_____
Official stamp_____
Designation_____
Date

**PART II
Appendix F****(Position and Address of the Building Official)
Form for Occupancy Certificate**

Reference number: _____

Permit number: _____

Address of the site:

Plot number: _____

Holding number: _____

Dag/Khatian number: _____

Mouza/Block/Sector: _____

Street name: _____

Municipal ward number: _____

Documents enclosed along with this form:

Type of work (Check one)

Develop Erect Demolish Alter

Name of the owner: _____

Contact address: _____

Post code: _____

Telephone no: _____

I hereby certify that the work having the above mentioned detailed particulars has been completed in accordance with the plan and design approved by the permit number cited and the provisions of the Bangladesh National Building Code. The owner has submitted all the required documents for issuance of occupancy certificate. Thus, I, hereby, certify that the holding may be occupied as _____ (mention the occupancy type).

Signature of the Officer_____
Name of the Officer_____
Official stamp_____
Designation_____
Date

PART III
Chapter 1
General Building Requirements

1.1 Scope

This Part of the Code puts forward classification of buildings based on occupancy or nature of use and deals with the general and specific requirements of each of the occupancy groups. Fire resistance requirements are expressed in terms of type of construction which shall conform to the specified fire-resistive properties.

1.2 Terminology

This Section provides an alphabetical list of the terms used in and applicable to this Part of this Code. In case of any conflict or contradiction between a definition given in this Section and that in any other Part of this Code, the meaning provided in this Part shall govern for interpretation of the provisions of this Part.

Accessibility	The provision in a plot or a building or a facility or any part thereof that can be approached, entered and used without assistance by persons with temporary or permanent physical limitations.
Accessibility Route	A continuous unobstructed path that starts from the entry and shall continue through all accessible elements and spaces within a plot and buildings or facilities thereof up to the exit termination.
Accessible	The term accessible or adaptable shall be used as a prefix for spaces or features which are designed for persons having physical limitation; such as accessible toilet, accessible kitchen, accessible lift, and so on.
Adaptable	See ACCESSIBLE
Area Planning Authority	A government or semi-government agency or a local body which has been legally designated to formulate land use or plans of the area under their jurisdiction.
Assembly	In a building or a portion thereof used for gathering of 50 or more persons for deliberation, worship, reading, entertainment, eating, drinking, awaiting transportation, or similar uses not limited to these; or used as a special amusement building, regardless of occupant load.
Atrium	A large volume space within a multistoried building having series of floor openings or corridors or similar elements in and around and floors are connected from there and series of openings or a glazing on roof or a portion thereof constructed with glazing and having a minimum two stories high. The word Atria or Atriums are the plural form of Atrium.

Balcony	A covered and hanging platform at a height of minimum 2.286 m from the plinth level of a building and having access from any floor level and which is laterally open to outer air by three sides up to 2.06 m in height and edges are protected with guards. Within an interior space, a balcony is a portion which are positioned sidewise as similar as Mezzanine.
Baluster	Single vertical member of a guardrail or a Handrail or a member of both which shall be complied with the provisions of this Code.
Balustrade	Plural form of BALUSTER.
Barrier	A wall or a partition or a floor slab or a ceiling within a building which confines and protects flow of smoke and fire from the exposed side of the barrier. The fire rating of barriers shall be complied with the provisions of this Code.
Basement	A floor of a building or a portion thereof which is situated as a whole or partially at depth of minimum 50 percent of ceiling height below formation level shall be called as a basement.
Building Line	The peripheral lines of a building mass or volume up to which the plinth area or any floor area may be lawfully extended within a plot.
Carriageway	A path including over bridge or bridge which is open to the outer air and may or may not be covered or roofed or an underpass, design and designated for vehicles only.
Ceiling Height	Height measured from the top of finished surface of floor level up to the bottom of roof or ceiling or suspended or false ceiling level or Beam drops. In case of multistoried building, Vertical distance in between two slabs from which deduction shall be made for any suspended or false ceiling or Beam drops. For slope or pitch ceiling or roof, the minimum value shall be the ceiling height.
Common Space Condition	See NON-SEPARATED SPACE CONDITION
Control Area	A space or a room within a building enclosed by barriers with the fire rated walls, floor and ceiling, where the quantity of hazardous material shall not be exceeded the maximum allowable quantity per control area for storing, displaying, handling, dispensing or using as per provisions of this Code.
Detached Occupancy	A building separated by distance in a same plot to accommodate different type of occupancies shall be termed as Detached Occupancy.

Development Authority	A government or semi-government agency or a local body which has been legally designated to carry out and/or control any works of land development of an area having jurisdiction.
Far (Floor Area Ratio)	FAR is a ratio between the area of a plot and the sum of floor areas of building or buildings are erected or intended to be erected thereof. In the buildings, there may have some specific and calculated floor areas which shall be treated as bonus or exempted from the total floor area calculation and such areas shall be specified by the authorities having jurisdiction.
Fire	An uncontrolled fire which poses threat to safety of life or property or both.
Fire Separation Distance	A minimum distance which to be maintained between potential sources and/or between structures for fire safety. In case of differences between building setback and the required minimum fire separation distance measurement; the higher value shall be implied.
Flood	A Land or a plot normally dry but submerges or drowns as whole or partially by over flown water from any source.
Flood Level	A measurement of height from an existing ground level or from top level of river water of an area or a locality recorded in a Flood Hazard Map by the authorities having jurisdiction.
Flood Prone Area	At least once in a year a dry ground of an area or a plot or a portion thereof flooded at a height of 1m or more shall be designated as a Flood Prone Area.
Floor Height	In a multistoried building, floor height shall be measured from the top of finished surface of the two successive floor slabs and the measurement of the top most floor shall be from the top of finished surface of the floor slab and the top of the finished roof, in case of the slope roof, measurement shall be taken up to pick of that slope.
Frontage	Irrespective of the entry provision to a plot, full or partial length of any sides of a plot which are abutted to roads or streets shall be designated as frontage.
Formation Level	Finished ground level of a plot. For hilly areas formation levels shall be the gradient of the plot surface.
Gallery	A special type of seating arrangement where each and every row or tier of seats are successively elevated to provide a clear view to audiences or spectators within and around a playground or outdoor or indoor stadium or within an auditorium or in a hall.

Guard	A vertical protective barrier erected up to a height along exposed edges of stairways, balconies and similar areas.
Head Room Clearance	A vertical distance measured from the top of finished floor level up to the bottom of ceiling or lowest roof level or bottom of beam drop or bottom of any hanging element within a space. In case of a stairway, a vertical distance measured from the bottom surface of flight or ceiling or beam drop to any outer edge point of a tread below and for the landings ceiling height measurement system shall be adopted to determine head room clearance.
Helistop	A designated area on ground or on water or on a portion of a building for helicopter landing or takeoff without servicing, repairing and refueling facilities.
High Rise Building	Any building which is more than 10-storey or 33 m high from reference datum. Building appurtenances like overhead water tank, machine room, communication tower etc. will not be considered in determining the height.
Lighting Shaft	A space within a building which is fully enclosed by all sides and shall be open to the sky to provide daylight to adjacent interiors and less than the dimensions that stipulated for minimum closed or internal courts of corresponding to the building heights.
Loft	An intermediate space in-between a floor or a ceiling and under a pitch or a slope roof of a building.
Mandatory Open Space	The spaces within a plot which shall remain unpaved with or without vegetation to allow water penetration and uncovered up to the sky from formation level of the building. No underground or above ground construction is allowed in such spaces.
Mezzanine Floor	Within one space where more than one floor exists, the floor at the lowest level shall be designated as main floor and each Intermediate floor is limited to an area which is not more than one third of the main floor under one roof or one ceiling, thus gives two or more useable floor levels. These types of intermediate floors shall be designated as mezzanine floors. Mezzanine floor may be as gallery or flat floor type and which also includes interior balcony.
Mixed Occupancy	When two or more occupancies are amalgamated in a building shall be termed as Mixed Occupancy.
Non Separated Space Condition	Walls or partitions between compartments, rooms, spaces or areas within a building or part of a building which are not separated by an approved fire rated barrier walls or partitions shall be designated as non-separated space condition or effective undivided single space.

Openings	Apertures or holes in any wall of a building that allow air to flow through and which are designed as open.
Opening, Vertical	An opening through a floor or roof of a building.
Open Space	Open space within a plot includes all spaces other than spaces covered by the Maximum Ground Coverage (MGC).
Plinth	Bases of the building and the elements that negotiate with the ground.
Plinth Level	Height of a covered finished floor which is just above the formation level and measured from the formation level up to the top of that finished floor.
Plinth Area	The elements from the building bases which are exposed above the formation level to form a covered floor area by joining the peripheral points of the elements which are intersected finished floor plane at the height of plinth level shall be designated as Plinth Area.
Plot	A scheduled piece or parcel of land which is classified and restricted to its intended use.
Ramp	A sloping walkway which is steeper than 1 in 20 but not steeper than 1 in 8 and shall have guard and handrail.
Ramp, Accessibility	A sloping walkway not steeper than 1 in 12.
Ramped Driveway	Ramped Driveways are inclined floors that provide access to vehicles between two levels. Ramped walkway when provided side by side of a ramped driveway shall be separated by safety guard rails and curbs. A sloping driveway or Ramped Driveway steeper than 1 in 8 shall not be credited as a component of means of exit.
Ramp Gradient	Ramp gradient refers to the ratio of the inclination of a ramp (height by length ratio) measured along the center line of the ramp.
Road Level	The road level means top surface at the center point of the road width which is used for site entry and shall be considered as the reference point for measuring height or depth of any development.
Roof	Weather exposed and uncovered surface of the topmost or the terminal ceiling of a building which may be horizontal or pitched or may have slopes shall be treated as the roof of a building.

Separated Occupancy	A building or a portion thereof separated by barriers with wall or ceiling slab that into two or more parts to accommodate different type of occupancies in different parts.
Separate Space Condition	Rooms, spaces or areas within a building when separated by approved barrier wall.
Separation Wall	This is a peripheral wall of a building or a building which shall be divided into two or more or a common wall between two buildings to control spreading of fire as per provisions of this Code.
Site	See PLOT
Smoke Draft Barrier	A vertical panel dropped from the ceiling of a building or portion thereof to protect and control the movement of smoke draft during fire. The construction of such smoke draft barriers shall be complied with the provisions of this Code.
Stage	An elevated platform which is designed or used for presentation of plays or lectures or other entertainments in front an assembly of spectators or audiences.
Stage, Interior	An elevated platform within a building which is designed or used for presentation of plays or lectures or other entertainment in front an assembly of spectators or audiences.
Stage, Legitimate	Ceiling Height of a stage from the top surface of the platform is 15.24 m or more shall be designated as a legitimate stage.
Storage Density	A storage or display of solid or liquid merchandises shall not be exceeded 976 kg/m ² or 814 L/m ² respectively and shall be limited to the exempted quantity of an actually occupied net floor area. Maximum height of display or storing of merchandises shall not be exceeded 1829 mm or 2438 mm respectively. Allowable Height and Quantity may be less depending on the total area and the ceiling height of a store or a display.
Street Or Road	An open to outer air and unobstructed space having required width and used by the public as pedestrian or walkway, or animal or vehicular movement or any combination of these for the purpose of access to a plot or plots and is connected with the national public transportation system other than railway track shall be designated as street or road which may or may not be paved.
Street Or Road Width	The width of any street or road shall be measured form any plot to its opposite or face to face plot distance. For the determination of a road width, measurements shall be taken up to the connection of the national public transportation system other than railway track from any plot and the least width shall be the road width.

Street Floor Level	A story or floor level of a building which is accessible at the main entrance of a building from the street or from the outside at ground level and the floor shall not be more than three risers above or below the grade level.
Structural Frame	All members or elements such as columns, girders, beams, trusses and spandrels which forms a frame and have direct connections with bearing and transferring as an integral and essential elements for the stability of a building or a structure as a whole.
Surge Prone Area	Expected occurrence of a surge or wave of water may flow above 1 m or higher from the formation level.
Tall Structure	A building used for human occupancy located more than 80m high from the center of the adjacent road level or from lowest level of the fire department vehicle access.
Terrace	A paved surface not steeper than 1 in 20 and adjacent to a building which is connected by a stairway or a walking ramp or at the same level of any floor below the roof level of a building and at least one side of that area is exposed to the weather and having the guards and open to the sky.
Universal Accessibility	See ACCESSIBILITY
Unprotected	The element that shall have no prerequisites of fire protection rating.
Ventilation Shaft, Natural	A space sidewise enclosed but open to sky used to provide ventilation as inlet and/or outlet to adjacent interiors of dimensions less than that stipulated for internal courts of corresponding to building heights.
Verandah	Portions of a building at any level which have ceiling or roof and at least one side open up to 2.13 m height to the outside air and have guards as per provisions of this Code.
Walkup Building	A multi storied building which does not have any mechanical means of vertical circulation other than stairway shall be designated as a walkup building and the maximum height of the walkup building shall be as per provision of this Code or as approved by the authority having jurisdiction.

1.3 Land Use Classification

A city or a township or a municipality or a union or any other habitat development shall be brought under a structured planning including detailed area planning to implement the intended land use pattern, transportation and maintaining environmental conditions by the development or planning authorities and shall be approved by the government. This land use classification may divide an area into zones such as residential, commercial, industrial, storage, green park, agricultural land, reserved area etc. or any combination of these. The land use zones shall be shown on the approved master plan of the area and the planning regulation shall clearly state the permitted occupancies, restricted occupancies and conditionally permitted occupancies for each zone.

1.4 Occupancy and Construction Classification of Buildings

Every building or portion there of shall be classified according to its use or character of occupancy. A brief description of such occupancy groups is presented in Table 3.1.1. Details of all occupancy group and sub-divisions are set forth in Sec 2.1 of Chapter 2 of this Part. Types of construction based on fire resistance are specified in Table 3.1.2. Details of such types of construction are set forth in Chapter 3 of this Part. Any development permit for a site or a location shall clearly mention the permitted occupancy and construction type in accordance to Tables 3.1.1 and 3.1.2 for the existing or proposed building.

Table 3.1.1: Summary of Occupancy Classification

Occupancy Type	Subdivision	Nature of Use or Occupancy	Fire Index*
A: Residential	A1	Single family dwelling	1
	A2	Two families dwelling	1
	A3	Flats or apartments	1
	A4	Mess, boarding houses, dormitories and hostels	1
	A5	Hotels and lodging houses	1
B: Educational Facilities	B1	Educational facilities up to higher secondary levels	1
	B2	Facilities for training and above higher secondary education	1
	B3	Pre-school facilities	1

Occupancy Type	Subdivision	Nature of Use or Occupancy	Fire Index*
C: Institution for Care	C1	Institution for care of children	1
	C2	Custodial institution for physically capable adults	1
	C3	Custodial institution for the incapable adults	1
	C4	Penal and mental institutions for children	1
	C5	Penal and mental institutions for adults	1
D: Healthcare Facilities	D1	Normal medical facilities	2
	D2	Emergency medical facilities	2
E: Business	E1	Offices	2
	E2	Research and testing laboratories	2
	E3	Essential services	2
F: Mercantile	F1	Small shops and market	2
	F2	Large shops and market	2
	F3	Refueling station	2
G: Industrial Buildings	G1	Low hazard industries	3
	G2	Moderate hazard industries	3
H: Storage Buildings	H1	Low fire risk storage	3
	H2	Moderate fire risk storage	3
I: Assembly	I1	Large assembly with fixed seats	1
	I2	Small assembly with fixed seats	1
	I3	Large assembly without fixed seats	1
	I4	Small assembly without fixed seats	1
	I5	Sports facilities	1
J: Hazardous Building	J1	Explosion hazard building	4
	J2	Chemical hazard building	4
	J3	Biological hazard building	4
	J4	Radiation hazard building	4

Occupancy Type	Subdivision	Nature of Use or Occupancy	Fire Index*
K: Garage	K1	Parking garage	2
	K2	Private garage	1
	K3	Repair garage	3
L: Utility	L	Utility	2
M: Miscellaneous	M1	Special structures	2
	M2	Fences, tanks and towers	1

* Fire Index: fire index is an absolute number, Occupancy group having same fire index may be permitted as mixed occupancy and different fire index shall be separated or detached as per provisions of this Code.

Table 3.1.2: Summary of Classification of Buildings Based on Types of Construction

Construction Group	Construction Type	Description
Group I: Non-combustible	Type I-A	4 hour protected
	Type I-B	3 hour protected
	Type I-C	2 hour protected
	Type I-D	1 hour protected
	Type I-E	Unprotected
Group II: Combustible	Type II-A	Heavy timber
	Type II-B	Protected wood joist
	Type II-C	Unprotected wood joist
	Type II-D	Protected wood frame
	Type II-E	Unprotected wood frame

1.5 Requirements of Plots

1.5.1 General Requirements

1.5.1.1 No building shall be constructed on any site which is water logged, or on any part of which is deposited refuse, excreta or other objectionable material, until such site has been effectively drained and cleared to the satisfaction of the Authority.

1.5.1.2 Provision shall be kept for any space within the plot left vacant after the erection of the building to be effectively drained by means of surface or underground drainage system.

1.5.1.3 Basic minimum sanitary waste and excreta disposal facility shall be created on the premises, whether or not the plot is served by a disposal system provided by any utility service authority or agency.

1.5.1.4 Written approval of the Authority or the appropriate drainage and sanitation authority shall be obtained for connecting any soil or surface water drain to the sewer line.

1.5.2 Clearance from Overhead Electric Lines

A building or any part thereof shall not be erected within, nor any auxiliary part of the building be allowed to come closer to the distance shown in Table 3.1.3 from any overhead electric line.

Table 3.1.3: Minimum Distances from Overhead Electric Lines

Line Voltage	Vertically (m)	Horizontally (m)
Low to medium voltage lines and Service lines	2.5	1.25
High voltage lines up to 33 kV	3.5	1.75
High voltage lines beyond 33 kV	3.5 plus 0.3 for each additional 33 kV or part thereof.	1.75 plus 0.3 for each additional 33 kV or part thereof.

1.5.3 Road Level, Formation Level and Plinth Levels

1.5.3.1 Road level shall be lower than the habitable formation level of an area, except that of a hilly region. When a road is designed and designated as a part of national disaster management system, formation levels shall be determined by the authorities having jurisdiction.

1.5.3.2 The formation level of a plot shall not be lower than the adjacent road levels, except that of a hilly region. For hilly region, the elevation of the formation level shall be determined by the authority having jurisdiction. Where areas are not susceptible to flood or water logging, the formation level shall not be more than 450 mm high from the surface level of the center line of the adjacent roads.

1.5.3.3 The plinth level of a building shall be at least 450 mm above the surface level of the center line of the adjacent road. In Flood or Surge prone area plinth level shall be determined by the development authority having jurisdiction.

1.5.4 Boundary Wall

1.5.4.1 Solid boundary walls of a plot or in between plots shall not be higher than 1.5 m or a boundary made of grill, screen, balustrade etc. with a maximum height of 2.75 m shall not require the permission of the Authority. For boundary walls made of a combination of solid wall and grill or screen, the solid wall portion shall not be higher than 1.5 m. The Authority may, on specific application, permit the use of higher boundary walls.

1.5.4.2 Construction of a boundary wall shall be capable to resist collapsing as per provision of this Code.

1.6 Plot Sizes

Plot divisions and plot sizes are part of integrated planning decision of detail area plan and shall be determined by the Area Development Authority having jurisdiction. Where no such guideline exists or yet to be undertaken, the criteria mentioned in Sec A.5 of Appendix A regarding plot size shall be applicable.

1.7 Means of Access

The provision of means of access is implied on an area or a plot when more than one plots are intended to be created or when more than one buildings are intended to be erected respectively, where such plots or buildings do not have frontage to or not approachable by a public or a private road or street. All buildings within such area or a plot shall have access facilities which shall be connected with national road transportation system. The components of means of access shall comply with the followings:

- (a) The access facilities shall meet the requirements of fire service vehicles and engines movement for rescue and fire extinguishment operation.
- (b) Where required for fire apparatus access roads shall have an unobstructed carriageway width of 4.8 m and the minimum vertical clearance shall be 5m. The width and vertical clearance of fire apparatus access roads may be increased as per requirement of the fire authority, if the clearances are not adequate to provide fire apparatus access.
- (c) Access roads longer than 30 m having a dead end shall be provided with appropriate provisions for turning around of the fire apparatus at the dead end.
- (d) The provision of fire apparatus stall be marked by approved sign.
- (e) For large Assembly Occupancy of I1, I3 and I5, width of the approach road shall not be less than 15 m.
- (f) The minimum width of the approach road for all plots other than residential and assembly occupancies mentioned in Sec 1.7(e) and Sec 1.7(g) shall be 10.8 m.

- (g) For area fully covered by private hydrant system with street side hydrant points and/or hydrants within the building equivalent to fire service and civil defense department's specification and the buildings have fire stairs as per provisions of this Code, the requirements of Sections 1.7(a), (b) and (c) may be exempted. This provision shall not be applicable for planning new developments. The minimum width of access roads for plot divisions in new developments shall follow guidelines of Table 3.F.1 of Appendix F.

1.7.1 Internal Access Road

Internal access road is legally restricted for thoroughfare to the citizens and/or reserved for a group of people of a plot or an area that shall have access provisions for the department of fire service and civil defense.

1.7.1.1 The width of access roads and drive ways in a plot or an area shall be decided by the number and height of the buildings served thereby.

Table 3.1.4: Maximum Permissible Length of Internal Access Roads in Non-Residential Plots

Width (m)	Maximum Permissible Length (m)
6	80
7	150
8	300
10.8 or more	Unlimited

1.7.2 Pedestrian Path or Walkway or Footpath

Any path including over bridge or bridge which is open to the outer air and may or may not be covered or roofed or an underpass design and designated for walkers only shall be designated as pedestrian path or walkway or footpath.

1.7.2.1 An uncovered paved pedestrian path that links buildings and the approach road shall not be included as a floor area of a building.

1.7.2.2 The walkways shall not be used for any other purpose than pedestrian movement and as accessibility route.

1.7.2.3 The minimum width of the pedestrian path shall not be less than the calculated width of connected corridor or passage or walking ramp of a building for entry or exit provided it is not enclosed by adjacent walls on both sides; for pedestrian paths enclosed by adjacent walls on both sides the minimum width shall be 1.25 m. For public buildings and places where high pedestrian movement is expected, Table 3.F.1 of Appendix F may be followed.

1.7.2.4 Pedestrian walkways as accessibility route in public buildings shall comply with the provisions of this Code. Any changes in elevation in accessibility route shall comply with the provisions of Appendix D (Universal Accessibility).

1.8 Open Spaces Within a Plot

1.8.1 Minimum open space requirements for the sides, rear and frontages of a plot shall be as per the provisions of this Code or the authority having jurisdiction. In absence of such guideline, provisions of Sec 1.8.2 to Sec 1.8.11 shall decide the provisions of open space for any building or buildings within a site. All such open spaces shall ensure access of the users.

1.8.2 At least 50 percent of the minimum open space in a plot shall remain unpaved with or without vegetation to allow water penetration.

1.8.3 The total open area in a plot on which a building of educational, institutional, health care occupancy is constructed shall not be less than 50 percent of the plot area.

1.8.4 The total open area in a plot on which a building of any occupancy, except those mentioned in Sec 1.8.3, is constructed shall not be less than 33 percent of the plot area.

1.8.5 For the purpose of Sec 1.8.2, Sec 1.8.3 and Sec 1.8.4, the total open area shall include all exterior open spaces and interior courtyards, but exclude the area of any lighting and ventilation shaft.

1.8.6 For approved row type or cluster type housing or site and service schemes, the requirement of Sec 1.8.3 shall be applicable.

1.8.7 Separation of Buildings in the Same Plot

1.8.7.1 More than one building in a plot shall comply with the requirements of means of access and setback distances in relation with the corresponding building height and the occupancy classification as per provisions of this Code and laws of the land.

1.8.7.2 To determine the separation distance between buildings of same height and same occupancy an equidistant imaginary line shall be drawn between the buildings where each building shall comply with requirement of setback and fire separation distance from that imaginary line.

1.8.7.3 Exception: Utilities under Occupancy L is incidental to operation in all type of occupancy except Occupancy J and shall not require the separation distance from the main occupancy. This exception shall not be applicable for Occupancy J.

1.8.7.4 When variation in either height or occupancy occurs, the imaginary line shall satisfy the setback distances for each individual building separately as shown in Figure 3.1.1.

1.8.7.5 Due to the common walls, row or semi-detached houses shall be treated as one building. For semi-detached houses separation distance in the detached sides shall comply with Sec 1.8.7.2 and Sec 1.8.7.3.

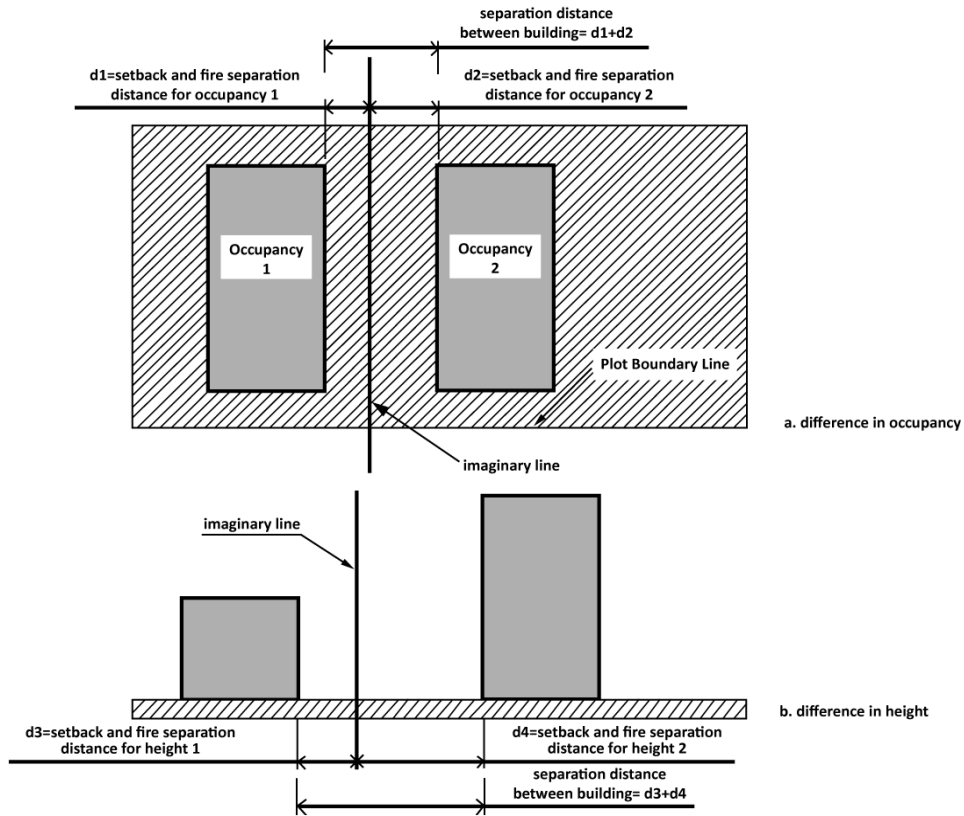


Figure 3.1.1 Separation distance for variation in occupancies and heights

1.8.8 Front Open Space for All Buildings

1.8.8.1 Irrespective of the height of building frontage open space, as defined in Figure 3.1.2, shall be constructed at a distance of at least 4.5 m from the center of the street or at least 1.5 m from the street-front property line whichever is larger.

1.8.8.2 In a corner situation where two frontages of a plot intersects each other and form a sharp corner a turning clearance with a minimum radius of 2 m shall be required as per guidelines of Figure 3.1.3. No construction or visual obstruction shall be allowed within such turning clearance space.

1.8.9 Side and Rear Separation Distances

1.8.9.1 The minimum side and rear open space, as defined as Figure 3.1.2, requirements of a plot for buildings of various occupancy classes shall be as specified in Table 3.1.5.

1.8.9.2 For approved row type residential, mercantile or office as may be permitted by the respective city or development authority and for approved affordable row type, cluster or site and service schemes, the requirement of side separation distance may be waived as per provisions of this Code.

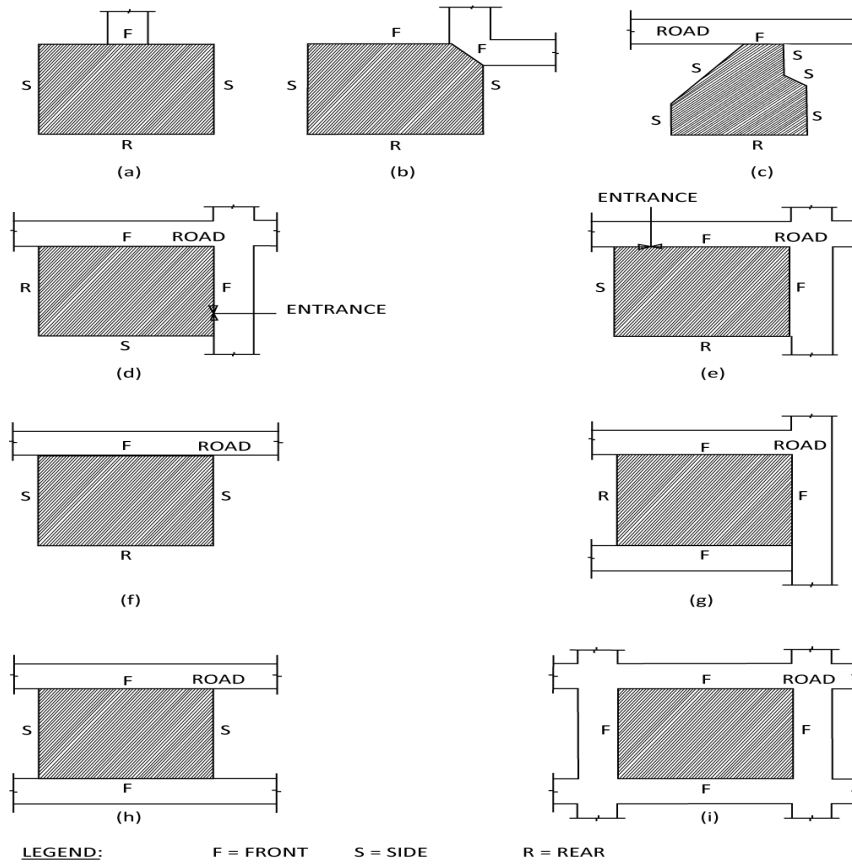


Figure 3.1.2 Definition of front, side and rear of a plot

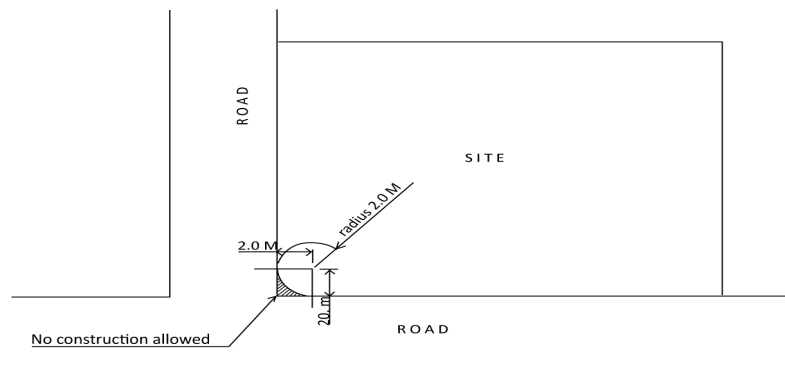


Figure 3.1.3 Restrictions for corner-plots

1.8.9.3 For semi-detached buildings approved by the city or development authority, which are permitted to be constructed with one side on the property line or with pounding gap, the minimum requirements of open space, specified in Sections 1.8.9.1 and 1.8.9.2, for the side opposite to that property line shall be increased as per Table 3.1.5. The requirement of separation distance for the remaining sides shall remain unchanged.

Table 3.1.5: Minimum Rear and Side Open Space Requirements of a Plot

Occupancy	Plot Size* (m ²)	Rear Separation Distance (m)	Side Separation Distance ^a (m)
Residential (Row type, not higher than 15m or 4 stories)	Not over 67	1.25	Nil ^b
	Over 67 to below 134	1.5	Nil ^b
Residential (Semi- detached, not higher than 10 stories or 33 m)	134 to 268	2.5	PG ^c , 2.5
	Over 268	3.0	PG ^c , 2.5
Residential (Detached, Not higher than 10 stories or 33 m)	134 to 268	2.5	1.25
Residential (Detached, Not higher than 10 stories or 33 m)	Over 268	3.0	1.25
Residential (Detached, Higher than 10 stories or 33 m)	Over 268	3.0	3.0
Institution for care	As permitted for this occupancy	3.0	3.0
Educational	As permitted for this occupancy	3.0	3.0
Assembly	Any	3.0	3.0
Business and Mercantile ^d (Not higher than 10 stories or 33 m) semi- detached	Any	1.5	PG ^c , 3.0
Business and Mercantile (Not higher than 10 stories or 33 m) Detached	Any	1.5	1.25, 2.5

Occupancy	Plot Size* (m ²)	Rear Separation Distance (m)	Side Separation Distance ^a (m)
Business and Mercantile ^d (Higher than 10 stories or 33 m) semi-detached	Over 536	3.0	PG ^c , 6.0
Business and Mercantile (Higher than 10 stories or 33 m) Detached	Over 536	3.0	3.0
Industrial	As permitted for this occupancy	As per provisions of this Code	As per provisions of this Code
Storage	As permitted for this occupancy	As per provisions of this Code	As per provisions of this Code
Hazardous	As permitted for this occupancy	As per provisions of this Code	As per provisions of this Code

Notes:

- ^a The two dimensions separated by comma stands for each of side separation distances of a semi-detached development.
- ^b No side separation distance is required between buildings up to 15 m or 4 stories even for independent plots.
- ^c PG stands for 'Pounding Gap', which is a calculated gap for safe distance to avoid pounding due to lateral loads as per provisions of Part 6 of this Code. This gap is not required if the adjoining plots are consolidated and built monolithically. Where pounding gap do not comply with the minimum separation distance, all walls within the separation distance shall be barrier walls.
- ^d Mercantile occupancies shared walls between adjacent plots shall only be allowed in accordance to the detail area plan (DAP) administered by the development authority.
- * For narrow plots (with site frontage below 12 m) of size 268 m² or above in unplanned areas, the local regulatory authority may allow semi-detached typology with a minimum side separation distance of 3m on the unattached side.

1.8.10 Courtyard and Interior Courtyard

An area having proper dimensions as per provision of this Code and open to the sky from the formation level and surrounded by a building or a group of buildings or walls or combination thereof shall be designated as Courtyard. The minimum size of such courtyard shall be derived from Table 3.1.6 depending on the height of the highest building or highest wall abutting the courtyard. The shorter side dimension of such courtyard shall not be less than one-third of the longer side dimension. All such courtyards shall remain open to sky over its entire cross section.

When the sum of exposure area of a courtyard to outer air through its adjacent walls exceed more than thirty percent area of its total peripheral enclosure, it shall be designated as Open courtyard. All other courtyards shall be designated as Interior or Closed courtyard.

1.8.10.1 If any room depends entirely on an interior open space for its natural light and ventilation, such interior open space shall be in the form of an interior courtyard open to the sky over its entire cross-section. The interior courtyard shall have the minimum dimensions depending on the height of the building as specified in Table 3.1.6. The shorter side dimension of such interior courtyard shall not be less than one-third of the longer side dimension.

Table 3.1.6: Minimum Area of Interior Courtyard

No. of Stories	Maximum Height (m)	Minimum Net Area of the Interior Courtyard, m ²
Up to 3	11	9
4	14	16
5	17	25
6	20	36
7	23	49
8	26	64
9	29	81
10	32	100
11	36	121
12-13	42	144
14-15	48	196
16-17	54	256
18-20	63	361

Notes:

1. For buildings above 20 storeys height, the size of the interior courtyard shall not be less than the square of one-third the height of the tallest wall abutting the courtyard.
 2. Enclosed open to sky spaces used to provide ventilation as inlet/outlet or daylight to adjacent interiors having dimensions less than that stipulated for internal courts of corresponding storey height given in this Table will be considered ventilation or lighting shafts and not interior courtyards and will follow minimum requirements stipulated in Table 3.1.11
-

1.8.10.2 The courtyard shall not be interrupted by any form of construction at the courtyard level, except landscaping, sculpture, walkways and water bodies.

1.8.10.3 If the courtyard is to serve as a component of the means of egress, it shall be accessible from all exit points at ground level.

1.8.11 Permitted Construction in the Mandatory Open Space

1.8.11.1 Landscaping, sculpture, walkways, water body shall be permitted in the open space. Any such construction shall comply with Sec 1.8.2 of this Chapter.

1.8.11.2 A maximum of 50 percent of the open space in a plot required by the provisions of Sec 1.8.8 and Sec 1.8.9 may be used for construction of garage, ramps, caretaker or guards quarter and other services auxiliary to and required for the main occupancy of the building, provided that the requirement of community open space in Occupancy A3 is attained, and building is not higher than 10 storey or 33 m, and provided further that conditions (a) to (g) below are satisfied:

- (a) No such construction permitted in the open space shall be higher than 2.75 m from the formation level of the plot, except for the tops of inverted beams or intermittent parapets, which may rise up to 3.25 m.
- (b) No window, door or ventilator shall be placed on any wall adjacent to the abutting plot or street.
- (c) Entrance to the garage or sloping drive way shall not be directly from a public road or street. Distance between the plot line adjoining the road and the entrance to a garage or a sloping drive way shall be kept at least 1.5 m or 4.8 m respectively.
- (d) Drainage from the roof or any other part of such construction shall not be allowed to discharge into the adjacent property. Drainage from any part shall not discharge directly into the street through spouts.

- (e) No structure or room shall be constructed over the garage or any other permitted service structure within the limits of the mandatory open space.
- (f) The roof of any such construction permitted in the mandatory open space shall not be used as a balcony or a terrace or in any such manner that would interfere with the privacy of the occupants of the adjacent property.
- (g) No toilet, generator room or electrical substation shall be constructed adjoining the abutting property or street.

1.8.11.3 Edges of slope roof or cornice of the building may be projected into the mandatory open space for a maximum distance of 750 mm. Such extensions shall not be accessible from the building at any level. The construction of a roof or a cornice shall be as such that rain or other water shall not fall from there into the adjacent plot or street.

1.8.11.4 Sunshades over exterior doors or windows of the building may extend into the mandatory open space for a maximum distance of 750 mm, provided that such sunshades are at least 2.5 m above the formation level of the ground.

1.8.11.5 Cantilever canopy at a clear height of at least 2.5 m above the formation level may project into the mandatory open space provided that a horizontal clearance of at least 1.5 m is maintained between the edge of the canopy and the property line. The top surface of such canopy shall not be used as a balcony and shall not be accessible from the building.

1.8.11.6 Balconies at levels higher than 6 m may project into the mandatory open space by not more than 0.9 m provided that a clearance complying the separation distances required in Sec. 1.8.8 and Sec. 1.8.9 are maintained between the edge of the balcony and the property line. Balcony shall be constructed as per provisions of this Code.

1.8.11.7 Water reservoirs, septic tanks, inspection pits, sewer and other underground or above ground service lines shall be permitted in the open space provided that no part of such construction is elevated more than 150 mm above the formation level and the 50 percent mandatory open space shall be unpaved green area.

1.9 General Height and Area Limitations

1.9.1 Authorities having jurisdiction shall permit the built area and building height for an area in accordance to the proposed density of the detail area plan (DAP). Where no such guideline is available, the height of the building shall be determined by the guidelines of Sections 1.9.2.1 to 1.9.2.9 and the built area will be a resultant of open space requirement and permitted height.

1.9.2 Height Limitations Based on Road Width

1.9.2.1 The maximum height of any building of Type I-A and Type I-B construction shall not exceed the nominal value of two times the sum of the width of the front road and the front open space (distance between the front property line and the building). For the purpose of fulfilling this requirement, the height limitations specified in Table 3.1.7 shall apply.

1.9.2.2 For plots having front road width not less than 23 m in an approved residential or business and/or mercantile area, there shall be no restriction on height for residential, business and mercantile buildings of Type I-A and I-B construction provided the minimum open space requirements specified in Table 3.1.8 are satisfied.

1.9.2.3 For Type I-C construction, the maximum permissible height of the building shall be 4 storeys or 14 m for values of two times the sum of the width of the front road and the front open space not less than 13.6 m.

Table 3.1.7: Height Limitations Based on Road Width and Front Open Space

2 × (Front Road Width Plus Front Open Space)	Maximum Permissible Height in Terms of Construction Classification							
	Group- I*						Group-II*	
	Type I-A and Type I-B		Type I-C		Type I-D		Type II-A, II-B, II-D	
	No. of storeys	Height (m)	No. of storeys	Height (m)	No. of storeys	Height (m)	No. of storeys	Height (m)
Below 10.6 m	3	11	2	8	2	8	2	8
10.6 m to below 13.6 m	4	14	3	11	2	8	2	8
13.6 m to below 16.6 m	5	17	4	14	3	11	3	11
16.6 m to below 19.6 m	6	20	4	14	3	11	3	11
19.6 m to below 22.6 m	7	23	4	14	3	11	3	11
22.6 m to below 25.6 m	8	26	4	14	3	11	3	11
25.6 m to below 28.6 m	9	29	4	14	3	11	3	11
28.6 m to below 31.6 m	10	32	4	14	3	11	3	11
31.6 m to below 34.6 m	11	36	4	14	3	11	3	11
34.6 m to below 37.6 m	12	39	4	14	3	11	3	11
37.6 m to below 40.6 m	13	42	4	14	3	11	3	11
40.6 m to below 43.6 m	14	45	4	14	3	11	3	11
43.6 m to below 46.6 m and so on in increments of 3 m	15	48	4	14	3	11	3	11

Notes:

1. For plots with front road width (Sec 1.9.2.5) not less than 23 m, residential and business and mercantile buildings of Type I-A and I-B construction shall have no height restriction subject to additional open space requirements (Sec 1.9.2.2).
2. The maximum permissible height for Type I-C construction is 4 storeys or 14 m (Sec 1.9.2.3).
3. The maximum permissible height for Type I-D and I-E of Group I construction and all types of Group II construction is 3 storeys or 11 m (Sec 1.9.2.4).

* For all Unprotected Construction Types I-E of Group I, Type II-C and Type II-E of Group II the maximum allowable storey and height shall be one storey and 8 m respectively.

1.9.2.4 For Type I-D and I-E of Group I construction and all types of Group II construction, the maximum permissible height of the building shall be 3 storeys or 11 m for values of two times the sum of the width of the front road and the front open space not less than 13.6 m.

1.9.2.5 For applying the provisions of Sections 1.9.2.1 to 1.9.2.4, the width of the front road for the layouts shown in Figures 3.1.2(b), (c), (d), (e) and (f) where the plot abuts more than one road, shall be taken as the average of the widths of the abutting roads.

1.9.2.6 For buildings more than six storeys or 20 m high, the following arrangements shall be provided:

- (a) Lifts of adequate size, capacity and number as per provisions of this Code.
- (b) Adequate fire protection and firefighting arrangements shall be as per provisions of this Code.
- (c) Adequate emergency fire escape stair depending upon the type of occupancy and occupancy load as per provisions of this Code.
- (d) For buildings with unlimited height (UL) provisions of Table 3.1.8 shall be mandatory.

Table 3.1.8: Minimum Separation Distance for Buildings of Unlimited Height

Occupancy	Minimum Separation Distance from Plot		
	Frontage	Rear	Side
	(m)	(m)	(m)
Residential	4.0	6.0	4.0
Business, Mercantile.	6.0	6.0	6.0
Educational, Institutional for care, Medical facilities.	6.0	6.0	6.0
Others	As per provision of this Code		

1.9.2.7 For buildings in the vicinity of airports or aerodromes, the height shall be limited by the requirements of the civil aviation authority, city or area development authority or other concerned agencies of the Government.

1.9.2.8 Where more than one construction type is permitted within a building as per provision of this Code among them the lowest fire resistance rated construction type shall be applicable for FAR allotment, and lowest fire resistance rating shall be applicable for the whole structure.

1.9.2.9 For road width above 8.8 m, the building form shall be contained within the pyramid formed by the sky exposure planes on all four sides or as many sides it has, following the guidelines of Figure 3.1.4.

1.9.3 Area Limitations based on FAR

1.9.3.1 Fire separation distance in terms of building setback and building occupancy type and construction type shall govern the FAR to restrict fire hazard volume. FAR shall be decided by the development authorities having jurisdiction.

1.9.3.2 For Occupancy in which unlimited FAR is permitted, the minimum open space requirements specified in Table 3.1.8 shall be applicable.

1.9.3.3 For the purpose of calculating FAR, the area of any floor including basement, of which at least two-third is used exclusively for car parking and the remaining one-third is used for purposes such as mechanical plant room, electrical substation, security cabin, reception booth, water tank, pump house, stairs, lifts and which are accessory to the main occupancy, shall be excluded from the calculation of the total floor area of the building.

1.9.3.4 For area with high public transport accessibility and high FAR the requirement for residential private parking should not be more than one car for every four dwellings or as per guidelines of the authority having jurisdiction.

1.9.3.5 In specifying FAR for a zone or an area, the city or area development authority shall follow the guidelines of Appendix-A (Development Control) and shall take into consideration the following:

- (a) Proximity to Public/Mass Transport network
- (b) Availability of Urban social infrastructure including urban open spaces
- (c) Environmental balance
- (d) Adequacy of present and proposed Utility services
- (e) Occupancy group and land-use permitted by master plan

- (f) Type of construction
- (g) Population density of the area
- (h) Width of approach roads
- (i) Traffic density in the approach roads
- (j) Local fire-fighting facilities
- (k) Parking facilities

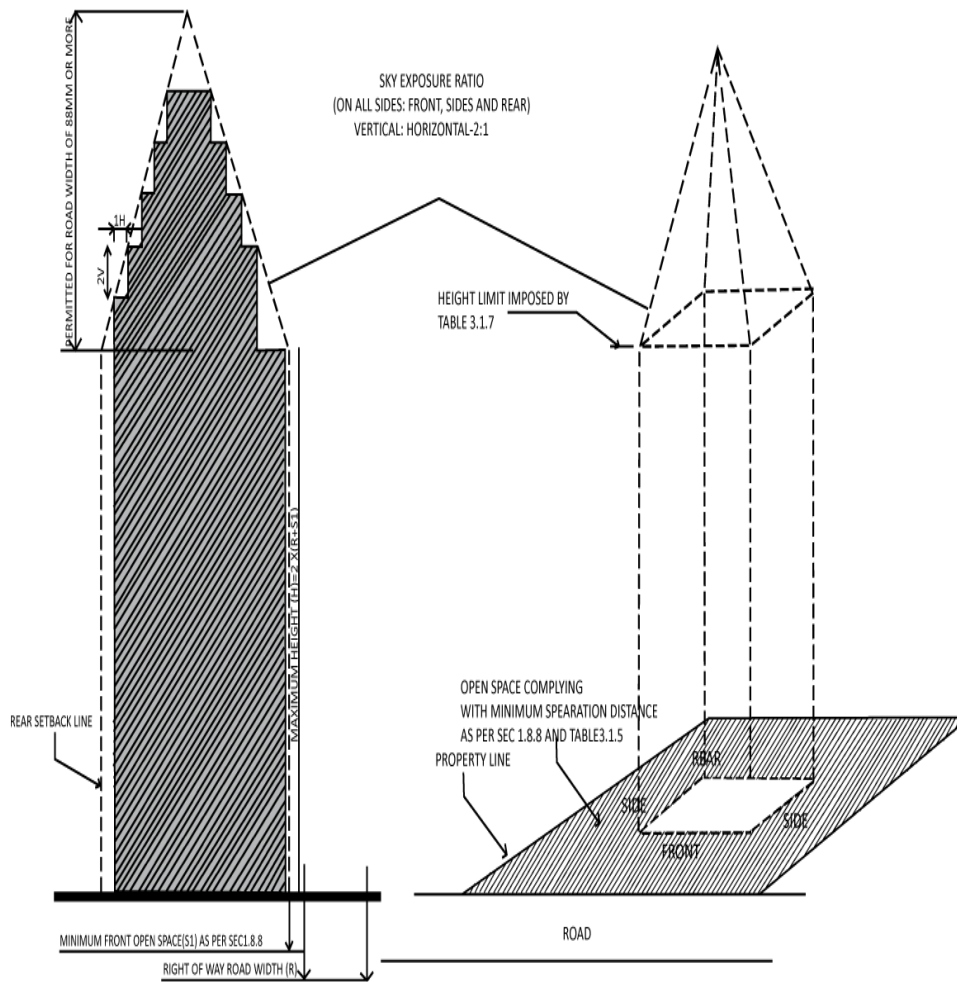


Figure 3.1.4 Limiting envelope for stepped tower structures

1.10 Off Street Parking Spaces

1.10.1 Off street parking requirement for a building or an area shall be decided by the development authority having jurisdiction. A suggestive guideline for off-street parking given in Appendix F might be followed.

1.10.2 Sloping drive way steeper than 1 vertical to 8 horizontal shall not be credited as a walking ramp. When a sloping surface used for both driveway and walking ramp shall be demarcated and the minimum width and sloping ratio of walkways shall be as per provisions of this Code. Sloping driveway entering below grade level shall be protected to prevent water flow into any level that they lead to.

1.11 Street Encroachment

No part of any building shall project beyond the property line or building line established by the provisions of this Code into the street, except the following:

- (a) Below Grade: The footing of the boundary wall adjacent to the street may encroach on to the street land not more than 0.3 m and shall rest at least at a depth of 1.5 m below grade.
- (b) Above Grade: Marquee, canopy or other temporary cantilever type projection from buildings of business and mercantile occupancy may project on the footpath of a road, provided that no part of such projection is below a height of 3 m from the footpath level and that the outer edge of the canopy is at a minimum clear horizontal distance of 0.25 m from the road side edge of the footpath. The canopy shall be so constructed as to be readily removable without endangering the building structure. No canopy shall project into a street without a footpath. Such canopies shall not project over Mandatory Open Space (MOS). Under no circumstances shall the top of the canopy be used by any floor of the building.

1.12 Community Open Space And Amenities

Community open space for an area or a building shall be decided by the development authority having jurisdiction. Where no such guide line exists or yet to be developed, the guidelines of Sections A.4 and A.5 of Appendix A and Sec B.3.2 of Appendix B shall be applicable.

1.13 Minimum Standard Of A Dwelling

Minimum standard of a dwelling shall be decided by the development authority having jurisdiction.

1.14 Requirements of Parts of Buildings

1.14.1 Plinth and Formation Levels

The plinth and formation levels of the building and the plot shall conform to the requirements of Sec 1.5.3.

1.14.2 Room Dimensions

1.14.2.1 Ceiling heights

- (a) All habitable rooms in non-air-conditioned residential, business and mercantile buildings, apart from kitchen, store room, utility room, box room and garage, shall have a ceiling height not less than 2.75 m measured from the finished surface of the floor to the underside of the finished ceiling, or false ceiling. A maximum of one-third of the floor area of such habitable rooms may, however, have a minimum ceiling height of 2.44 m. For air-conditioned rooms in such buildings, the minimum ceiling height shall be 2.44 m.

In the case of pitched roof without a horizontal ceiling the lowest point of the finished ceiling shall be at least 2 m above the finished surface of the floor and the average height of the ceiling shall not be less than 2.44 m.

- (b) The minimum clear head room under the ceiling, folded plate, shell etc. and under the false ceiling or duct in an air-conditioned room shall not be less than 2.44 m. The minimum clear distance between the floor below and the soffit of a beam shall not be less than 2.15 m.
- (c) The requirements of ceiling height for buildings of occupancy other than residential and business and mercantile shall be as follows:

Table 3.1.9: Minimum Ceiling Heights for Different Occupancies

Occupancy	Minimum Ceiling Height
Educational, Institutional, Health Care, Assembly.	3 m for non-air-conditioned and 2.6 m for air-conditioned buildings.
Industrial, Storage, Hazardous.	3.5 m for non-air-conditioned and 3.0 m for air-conditioned buildings.

1.14.2.2 Room sizes

All habitable rooms used for sleeping and other purposes of a dwelling unit shall not be less than 9.5 m² of net floor area with a minimum width of 2.9 m and shall comply with indoor air quality requirement as per provisions of this Code. Other non-habitable rooms in the dwelling unit shall have a minimum area of 5 m² with a minimum width of 2 m.

1.14.3 Kitchen

1.14.3.1 The minimum clear height of kitchen measured from the finished surface of the floor to the finished ceiling shall be 2.75 m, except for any floor trap of the upper floor which shall have a minimum clearance of 2.15 m above the finished floor. The minimum clear height of kitchen shall be 2.15 m where mechanical exhaust is installed.

1.14.3.2 The minimum floor area of kitchen without provision for dining shall be 4 m² with a minimum width of 1.5 m. The minimum floor area of a kitchen which is intended to provide dining or occasional sleeping space shall be 7.5 m² with a minimum width of 2.2 m.

1.14.3.3 Every kitchen shall be provided with a kitchen sink or other means for washing utensils. The waste water shall be discharged into the waste water pipe or drain as per provisions of Part 8.

1.14.3.4 The floor of the kitchen shall be slip-resistant and water tight.

1.14.3.5 Every kitchen shall be provided with window having a minimum area of 1 m² which shall open to the exterior or to an interior open space of adequate dimensions complying with Sec 1.19.

1.14.3.6 It is recommended that all kitchens should be designed as accessible kitchens for people with disability considering the door width, accessible route, turning clearance within the kitchen, counter heights, placement of fixtures, knee and toe clearances under counters and other relevant criteria in compliance to the guidelines of Appendix D.

1.14.4 Bathroom and Toilets

1.14.4.1 The height of any bathroom, toilet or water closet shall not be less than 2.15 m measured from the finished floor surface to the finished ceiling or false ceiling or to the lowest point of any trap of the upper floor's plumbing system.

1.14.4.2 The minimum requirement of floor area and width of a bathroom with 3 fixtures, 2 fixtures or single fixture shall conform to the space standards of Table 3.1.10.

1.14.4.3 Details for requirement of adaptable or accessible toilets shall follow the guidelines of Appendix D.

Table 3.1.10: Bathroom Space Standards

Facility	Minimum Width (m)	Floor Area (m ²)
Water closet + bathing + hand washing	1.25	3.00
Water closet + bathing	1.00	2.80
Bathing only	1.00	1.50
Water closet only	1.00	1.20
Adaptable toilets	1.50	as per Appendix D

1.14.4.4 No bathroom or toilet containing water closet shall open directly into any kitchen or cooking space by a door, window, ventilator, fanlight or any other opening. Every such bathroom or toilet shall have a door completely shutting it off from the exterior.

1.14.4.5 Every bathroom, toilet and water closet shall be located against an exterior wall or wall on the interior open space (see Sec 1.8.10), except where they are ventilated through an interior lighting and ventilation shaft. Such interior lighting and ventilation shafts shall have the minimum dimensions specified in Table 3.1.11 for different heights of buildings. In addition, shafts for buildings exceeding 6 storeys or a height of 20 m shall be mechanically ventilated. All shafts must be accessible at the ground floor level for cleaning and servicing purposes.

Table 3.1.11: Minimum Dimensions of Lighting and Ventilation Shaft

Building Height		Minimum Net Cross Sectional Area of Shaft	Minimum Width of Shaft
No. of Stories	Height (m)	(m ²)	(m)
Up to 3	Up to 11	1.50	1.00
4	14	3.00	1.20
5	17	4.00	1.50
6	20	5.00	2.00
Over 6*	Over 20	6.50	2.50

* Mechanical ventilation of the shaft shall be provided for buildings over 6 stories high.

Shaft dimensions shall conform to mechanical design considerations.

1.14.4.6 Floors of bathrooms, toilets or water closets shall be treated with water repellent material and shall be water tight. All bathroom walls or partitions shall be treated with non-absorbent water repellent smooth impervious finish material to a height of not less than 1 m above the finished floor level. The floor shall be sloped gently towards gratings or openings of the floor traps.

1.14.4.7 All public buildings shall have adaptable toilet as per requirement of the development authorities having jurisdiction. Each dwelling unit shall have at least one adaptable toilet. The details of such toilet shall comply with requirements of Appendix D (Universal Accessibility).

1.14.5 Stairways

1.14.5.1 Limiting Dimensions

The minimum width of the staircase for various occupancies shall be as specified in Table 4.3.6 of Part 4.

1.14.5.2 Sum of two risers and one tread excluding nosing dimension shall not be less than 610 mm and not more than 648 mm. All Risers and Treads shall be identical in consecutive two flights starting from one floor to another floor. Difference between two consecutive risers or treads shall not be more than 5 mm. The combination of riser and treads shall comply with Table 4.3.4 Chapter 3, Part 4.

1.14.5.3 The maximum flight height between landings shall not be more than 3660 mm. For Assembly occupancy maximum flight height between landings shall not be more than 2440 mm.

1.14.5.4 The minimum clear head room between flights of a staircase shall be 2.15 m. The clear head room may be reduced to 2.03 m for not more than three flights in any staircase.

1.14.5.5 The minimum clear height of any passage below a landing providing access to non-habitable and service spaces shall be 2.03 m. The minimum clear height of all other passages and spaces below a landing shall be 2.15 m.

1.14.5.6 Handrails shall have a minimum height of 0.9 m measured from the nose of stair to the top of the handrail.

1.14.6 Mezzanine Floor

1.14.6.1 Each mezzanine floor area in a space shall not exceed one-third of the main floor area. The area of the mezzanine shall be included in calculating the FAR.

1.14.6.2 The clear headroom both over and under the mezzanine floor shall be at least 2.2 m.

1.14.6.3 The lighting and ventilation of the space both over and under the mezzanine floor shall not be obstructed in any way.

1.14.7 Lofts

1.14.7.1 Space under slope roof termed lofts shall not be used as a habitable space where minimum ceiling height is less than the requirement but more than 1.5 m.

1.14.7.2 The minimum ceiling height requirements for various rooms specified under Sections 1.14.2.1, 1.14.2.2, 1.14.3 and 1.14.4 shall be maintained under the loft.

1.14.7.3 A maximum of 25% of the floor area of any room may be covered by a loft, except bathrooms, toilets, water closets, store rooms and corridors where the whole area may have an overhead loft.

1.14.7.4 The loft shall not interfere with the lighting and ventilation of any room.

1.14.8 Cabins or Chambers

1.14.8.1 Cabins or Chambers created by removable partitions on open floor shall have a minimum area of 3m².

1.14.8.2 Clear passages at least 0.75 m wide (or as stipulated in Part 4) shall be maintained between the cabins leading to a means of exit which shall in no case be further than 16 m from any cabin.

1.14.8.3 A clear gap of at least 300 mm shall be maintained between the top of the partition walls enclosing the cabin and the ceiling, unless the cabin is exposed to the exterior deriving natural light and ventilation or is artificially lighted and ventilated.

1.14.9 Store Room

A store room provided in a dwelling unit of a residential building shall have a minimum area of 1.5 m² with a minimum width of 1 m. The clear height of the store room shall not be less than 2.2 m.

1.14.10 Private Garage

Private garage in residential occupancy A1 and A2 building shall have a minimum clear height of 2.03 m. The minimum area of the parking stall in a garage shall be decided in accordance with the provision of Sec F.7.1 of Appendix F.

1.14.11 Basement

Any underground floor of a building wholly or partially below formation level shall be called a basement and shall satisfy the requirements of the following sections.

1.14.11.1 Subject to the provision of Sec 1.9.3.3, the area of the basement shall be included in the calculation of FAR.

1.14.11.2 The walls and floors of the basement shall be damp-proof and water-proof as per provision of this Code. The basement shall be protected against surface and sub-surface waste water intrusion.

1.14.11.3 The basement shall be lighted and ventilated as per provision of this Code.

1.14.11.4 The staircases of a building serving above grade level also entering into below street floor level shall be enclosed by barrier wall with two door smoke proof vestibule shall have minimum 2 hours fire resistance time.

1.14.11.5 Ramp provided as walkways shall not be steeper than 1 vertical in 8 horizontal.

1.14.11.6 The clear height of the basement below soffit of beams shall not be less than 2.03 m.

1.14.12 Entrance to the Building

All buildings shall have a covered entrance or other covered area for callers waiting at the door. The main entrance door to the building shall not open into an uncovered exterior. All public buildings shall have universal accessibility as per provisions of Appendix D of Part 3.

1.14.13 Roof Drainage

1.14.13.1 The roof of a building shall be constructed in such a manner that rain water is drained freely away from the building without causing dampness of the roof or the walls of the building or of an adjacent building.

1.14.13.2 Water from the roof shall not be discharged into the adjacent property or street.

1.14.13.3 For one or two storied buildings with flat or pitched roof, rain water may be discharged directly to the ground, in which case the roof shall have extended eaves or cornices to direct the water away from the walls.

1.14.13.4 For other buildings, gutters or parapets shall be provided to direct the water to the piping of an adequate rain water drainage system.

1.14.13.5 The roof shall be impermeable or shall be treated with an impervious material to make it effectively water tight. Flat concrete roofs shall be topped with an impervious layer of lime concrete or other effective means of waterproofing. All flat roofs shall be sloped gently towards gutters, gratings or mouths of the rain water drainage pipes.

1.14.13.6 For sustainable development, building may have rain water harvesting system as stipulated in Part 8, Chapter 7.

1.14.14 Parapet

All accessible flat roofs shall be enclosed by parapets or guardrails having a height of at least 1 m. All such parapets and guardrails shall be designed to withstand the lateral forces due to wind and occupancy in conformity with the provisions of Part 6 of this Code.

1.14.15 Septic Tank

A septic tank shall be provided within the premises for disposal of sewage, whether any public sewer is available or not. The location, design and construction of the septic tank shall conform to the requirements of this Code.

1.15 Landscaping

1.15.1 Plantation of trees and shrubs within the open spaces of a plot aimed at enhancing the environmental quality of the building shall comply with the requirements of this Section.

1.15.2 Trees and shrubs shall be planted judiciously to meet the requirements of shade and sunshine, to control noise and dust, to provide privacy and to improve visual quality, without jeopardizing natural ventilation and lighting of a building.

1.15.3 Species of trees shall be so chosen and planted that their roots do not endanger the building foundation and their branches do not interfere with the building superstructure. This shall be achieved by maintaining sufficient distance between the trees and the building depending on the species of the tree.

1.16 Damp-Proofing and Waterproofing

Foundation, floor slabs, walls and roof of a building shall be damp proof, water proof and weather proof in accordance with the provisions of Part 6 of this Code.

1.17 Existing Buildings

1.17.1 Existing buildings and structures in their present occupancy condition shall not be required to be in full compliance with all the requirements of this Part of this Code. Additions or alterations to such existing buildings or change of use thereof shall not be permitted if such addition, alteration or change of use or occupancy is likely to render the building more hazardous with respect to fire safety, life safety and sanitation than it was before.

1.17.2 Any horizontal or vertical extension of an existing building or any change of use thereof shall subject the altered building or occupancy to the provisions of this Code for a new building. The building together with the additions and changes shall not exceed the height, area and open space requirements for new buildings specified in this Code.

1.17.3 All buildings and structures, both new and existing shall be maintained in a safe and sanitary condition as provided for in this Code. To determine compliance with this requirement, the Authority may cause the building or structure to be periodically inspected.

1.17.4 Any proposed change in an existing building or structure shall have to satisfy the requirements set forth in Part 6 of this Code.

1.18 Buildings and Areas of Historical or Architectural Value

1.18.1 Buildings and areas of Historical value are part of our heritage and cultural inheritance and should therefore be protected. Similarly buildings and works under the jurisdiction of and identified by the Authority as having architectural value shall also be protected. The identification, listing and classification of all such buildings and places of historic or architectural values shall follow the guidelines of Chapter 3 of Part 9, Section 1.5 of Part 1 and Section 3.14 of Part 2.

1.18.2 Repairs, alterations and additions necessary for the preservation, restoration, rehabilitation, continued use or adaptive reuse of such historic buildings and structures, and of buildings and works of architectural value may be exempted by the Authority from having to be in full compliance with all the requirements of this Code, provided that the restored building or structure will be no more hazardous, if any, than the existing conditions in terms of life safety, fire protection and sanitation. All such buildings and places shall comply with the provisions for conservation of heritage buildings or area of Part 9.

1.19 Ventilation, Lighting and Sanitation

1.19.1 All rooms and interior spaces designated for human occupancy shall be provided with means of natural or artificial lighting and natural or mechanical ventilation as per provisions of this Code. At least one side of all habitable rooms shall be exposed to an exterior or an interior open space or to a balcony or verandah exposed to an open space.

1.19.2 All buildings shall have water and sanitation facilities as per provisions of this Code.

1.19.3 Every kitchen shall have facility for washing of utensils.

1.19.4 Every building or independent unit thereof shall be provided with at least one water closet.

1.19.5 All naturally ventilated and illuminated interior spaces, staircases and other areas of human occupancy in a building shall have windows or ventilators opening directly to the exterior or an interior open space or to a verandah. Ventilation of bathrooms may also be achieved through ventilation shafts as provided for in Sec 1.14.4.5.

1.19.6 All habitable and non-habitable spaces within a building shall have the following minimum aggregate area of openings in the exterior wall, excluding doors, expressed as percentage of the net floor area:

Table 3.1.12: Dimension of Openings for Different Uses

Space	Percent of Net Floor Area
Habitable rooms such as those used for sleeping, living, study, dining etc.	15
Kitchens*	18
Non-habitable spaces such as bathrooms, store, staircase and other utility	10

* Minimum height from the window sill of a kitchen shall be 450mm above cooking range. Air flow on cooking range shall be restricted.

1.19.6.1 An enclosed staircase shall have windows not less than 1 m² in area on exterior walls of every landings as per provisions of this Code.

1.19.6.2 Toilet and bathroom windows shall open to the exterior or an approved ventilation shaft and the operable area shall not be less than 1 m².

1.19.7 The required minimum average intensity of illumination in a habitable space at a height of 750 mm above the floor level shall be 65 lux. Any point in a room more than 7 m away from an exterior window shall be considered to be not illuminated by daylight unless measurement of illumination gives an intensity of 65 lux or more.

1.19.7.1 The required intensity of illumination for various tasks in a building shall be as specified in Chapter 1 of Part 8.

1.19.7.2 Whenever the illumination achieved by daylight is not sufficient or occupancy at night is necessary, artificial lighting shall be installed to supplement daylight, or to provide the required night lighting, in accordance with the provisions of Chapter 1 of Part 8.

1.19.8 Protected openings, when and where are installed shall not be normally operable from the inside of a building. Such openings however, shall not be credited towards meeting any ventilation requirements.

1.19.9 The requirements of opening areas specified in Sec 1.19.6 shall suffice for ventilation provided that the windows or ventilators forming the opening are operable. When part of a window area is made of fixed glazing, only the operable portion shall be counted in aggregating the opening area.

1.19.9.1 To achieve the desired indoor air quality by natural means, an interior space shall preferably have minimum two openings on two different walls where the opening acting as inlet must be an exterior wall and the summation of the net opening area on walls shall not be less than 5% of the net floor area thereof.

1.19.9.2 Mechanical ventilation, when provided, shall conform to the requirements of Chapter 3 of Part 8.

1.20 Air-Conditioning and Heating

When air-conditioning and heating system are installed, an indoor air quality shall be maintained as per provisions of Chapter 3 Part 8.

1.21 Provision of Lifts and Escalators

Wherever required by this Code or desired by the owner for comfort, lifts and escalator facilities shall be planned, designed and installed in accordance with the provisions of Part 4 and Part 8 of this Code. The minimum size of a lift lobby shall be 1.5 m x 1.5 m. For accessible lift guidelines of Appendix D shall be applicable.

1.22 Sound Insulation

Acoustical design of a building to attain the desired noise levels shall be performed in accordance with the provisions of Chapter 4 Part 8.

1.23 Thermal Insulation

Thermal comfort in a building shall be achieved through adequate ventilation and thermal insulation of walls and roof.

1.24 Lightning Protection of Buildings

Lightning protection measures shall be installed on all buildings whose exposure conditions indicate the likelihood of lightning strike and consequential hazard to life and property. The requirement of lightning protection systems shall be assessed and they shall be designed and installed in accordance with the provisions of Chapter 2 Part 8.

1.25 Rat Proofing and Termite Proofing Of Buildings

Rat proofing and termite proofing measures shall be undertaken on the basis of the degree of protection desired from rats and termites. Any chemical used for the control of rats and termite shall be free from environmental hazards. Periodic inspections shall be undertaken for effective protection against rats and termites.

1.26 Requirements For Buildings In Flood Prone and Coastal Regions of Bangladesh

The specifications of this Section shall be applicable to all buildings located in the flood or surge prone areas in addition to other requirements of this Code.

- (a) The planning and development control authority of the city, township, municipality or region where this Code is intended to be applied shall delineate any area having a potential for being flooded under at least 1 m deep water due to flooding as Flood Prone Area (FPA). The provisions of Sec 1.26.1 shall be applicable to areas designated as FPA. There shall be a design flood level in the FPAs which shall be recommended by the Authority to be used in interpreting the provisions of this Section.
- (b) Similar delineation shall be made in the coastal regions on the basis of expected occurrence of a surge or wave run-up of 1 m or higher. Such areas shall be designated as Surge Prone Area (SPA). The provisions of Sec 1.26.2 shall be applicable to buildings located in the SPAs. There shall be a design surge height in the SPAs which shall be recommended by the Authority to be used in interpreting the provisions of this Section.

1.26.1 Flood Prone Areas

1.26.1.1 Elevation

The habitable floors of a building located in the flood prone area shall be elevated above the design flood level. Buildings up to two storeys high shall have accessible roof with an exterior stair. Buildings having three storeys or more height, the floor immediately above the design flood level shall be accessible with an exterior stair.

Exceptions:

- (a) Except for Occupancy A (Residential), any occupancy may have floors below the design flood level in accordance with the provisions of Sec 1.26.1.3.
- (b) Floors which are used only for building access, exits, foyers, storages or parking garages may be located below the design flood level in accordance with the provisions of Sec 1.26.1.2.

1.26.1.2 Enclosures below design flood level

There shall be no enclosed space below the design flood level except for building access, exits, foyers, storage and parking garages. There shall be vents, valves or other openings in the walls of the enclosed spaces which shall equalize the lateral pressure of the water. The bottom of such openings shall not be higher than 300 mm above the finished grade. There shall be at least two openings for each enclosure in a building. The total net area of openings for an enclosure shall be at least 0.4 m^2 or 7 percent of the floor area of the enclosure, whichever is greater.

1.26.1.3 Flood-resistant Construction

Floors constructed below the design flood level under the provisions of Exceptions in Sec 1.26.1.1 shall comply with the following requirements:

- (a) Floors and exterior walls of such floors shall have a construction impermeable to the passage of water.
- (b) Structural components of such floors shall be capable of resisting the hydraulic and buoyant forces resulting from the occurrence of floods at the design flood level. Design requirements in such cases are specified in Chapter 1, Part 6.
- (c) Vents, openings and valves provided below the design level shall have water-tight closures capable of resisting any structural forces resulting from the occurrence of the design flood.
- (d) Penetrations made for electrical, mechanical or plumbing installations shall be made water-tight to prevent any penetration of flood water. Sewerage systems having opening below the design flood level shall have a closure device to prevent backwater flow during the occurrence of floods.

1.26.2 Surge Prone Areas

1.26.2.1 Elevation

The habitable floor of any building in a surge prone area shall not be located below the design surge height. For buildings of height two storeys or less the roof shall be accessible with an exterior stair. For buildings having three storeys or higher, the floor immediately above the design surge level shall be accessible with an exterior stair.

Exception:

Footings, mat or raft foundations, piles, pile caps, columns, grade beams and bracings may be constructed below the design surge height.

1.26.2.2 Enclosures below Design Surge Height

Spaces of a building in the SPAs below the design surge height shall not obstruct any flow of water during the occurrence of surge.

Exception:

Structural or non-structural members serving as entries or exits may be constructed below design surge height.

1.26.2.3 Foundations

Foundations of the buildings erected in the SPA's shall be located well below the ground level so that they are protected from erosion or scour during the occurrence of surge. If piled foundations are used, they shall be designed to withstand with adequate factor of safety and the loss of support due to scour. Design of the foundations shall conform to the requirements of Chapter 3 Part 6.

1.27 Requirements for Buildings In Other Disaster Prone Areas

In hilly region, authority shall ask for a special site drainage plan conforming to the area drainage network before approval of any building work. This shall apply for all buildings to be constructed in hilly areas where there is the danger of failure of slopes, including mudslides, flash floods and soil erosion. Such failures may occur in hilly areas, where the angle of slope is greater than 30°. Prevention of failure of slopes shall be achieved by the following measures:

- (a) Retaining walls to prevent soil erosion as per provisions of Part 6 of this Code.
- (b) Weep holes to allow water pressure balancing from the water logged soil on the retaining wall.
- (c) Adequate site drainage respecting the natural topography of the site and surrounds.
- (d) Use of vegetation to retain the top soil and bonding quality of the soil.
- (e) Protection of soil by catchment pools to prevent soil erosion due to discharge from elevated level onto the ground.

1.28 Special Provision For Storage of Dangerous Goods and Their Classification

1.28.1 Any substance including mixtures and solutions shall be assigned to one of the following Classes for any Occupancy if it crosses the limits of exempted quantities as per Table 3.2.5 of Part 3, Section 2. Some of these classes are subdivided into divisions also. The numerical order of the classes or divisions is not the representative of the degree of danger. These classes including their divisions are listed below:

Class 1: Explosives

- Division 1.1: Substances and articles which have a mass explosion hazard.
- Division 1.2: Substances and articles which have a projection hazard but not a mass explosion hazard.
- Division 1.3: Substances and articles which have a fire hazard and either a minor blast hazards or a minor projection hazards, but not a mass explosion hazard.
- Division 1.4: Substances and articles which present no significant hazard.
- Division 1.5: Very insensitive substances which have a mass explosion hazard.
- Division 1.6: Very insensitive substances which do not have a mass explosion hazard.

Class 2: Gases

- Division 2.1: Flammable gases
- Division 2.2: Non-flammable, non-toxic gases
- Division 2.3: Toxic gases

Class 3: Flammable Liquids**Class 4: Flammable Solids; Substances Liable to Spontaneous Combustion; Substances which, in contact with Water, Emit Flammable Gases:**

- Division 4.1: Flammable solids, self-reactive substances and solid
- Division 4.2: Substances liable to spontaneous combustion
- Division 4.3: Substances which, in contact with water, emit flammable gases

Class 5: Oxidizing Substances and Organic Peroxides

- Division 5.1 Oxidizing substances
- Division 5.2 Organic peroxides

Class 6: Toxic and Infectious Substances

- Division 6.1: Toxic substances
- Division 6.2: Infectious substances

Class 7: Radioactive Material**Class 8: Corrosive Substances**

Class 9: Miscellaneous Dangerous Substances and Articles

The quantity and procedure for storage, merchandising, handling, processing, packaging, transportation, shipment and uses of all dangerous goods of above classification shall be regulated as per guidelines of Explosive Act and other relevant Acts and as per rules of Bangladesh Shipping Corporation for safe handling of container for dangerous goods. The signs and symbols for all such goods shall comply with the requirements of Bangladesh Shipping Corporation's guidelines.

1.28.2 HS Code, Proper Shipping Names and UN Numbers

First Schedule of Bangladesh customs tariff that is Harmonized System code shall be used for the description of any substances and its corresponding UN number shall be used for proper shipping name and for the classifications of dangerous goods. The storage and use of all such substances and goods shall be controlled as per provision of this Code and explosive control act.

1.29 List of Related Appendices

Appendix A	Development Control and Planning
Appendix B	Minimum Standard Housing
Appendix C	Cluster Planning
Appendix D	Universal Accessibility
Appendix E	Building Types
Appendix F	Road Hierarchy, On-street and Off-street Parking

PART III
Chapter 2**Classification of Buildings Based on Occupancy****2.1 Occupancy Classification**

2.1.1 Every building or portion thereof and land-use shall be classified according to its use or the character of its occupancy as a building of Occupancy A, B, C, D, E, F, G, H, I, J, K, L or M as defined below:

Occupancy A:	Residential
Occupancy B:	Educational
Occupancy C:	Institution for care
Occupancy D:	Health Care
Occupancy E:	Business
Occupancy F:	Mercantile
Occupancy G:	Industrial
Occupancy H:	Storage
Occupancy I:	Assembly
Occupancy J:	Hazardous
Occupancy K:	Garages
Occupancy L:	Utilities
Occupancy M:	Miscellaneous

2.1.2 Utilities under Occupancy L is incidental to operation in all other type of occupancy except Occupancy J shall be considered as non-separated use of the main occupancy but shall be taken special safety measure as per provision of this Code.

2.1.3 Any occupancy or use type not mentioned specifically in Table 3.2.6 (A-Z list) or elsewhere in this Code shall be classified by the Board of Appeals under the occupancy group to which its use most closely resembles, considering the life safety and fire hazard.

2.1.4 Each occupancy group shall be subdivided as detailed in the following sections. The detail classification including mixed occupancy provided in the Table 3.2.6 (A-Z list) is non-exhaustive. If there is any use or character of occupancy in a building which is not mentioned here, it shall be classified as per provision of Sec 2.1.3 of this Chapter.

2.1.5 Occupancy A: Residential Buildings

This occupancy type shall include any building or portion thereof providing sleeping and living accommodations to related or unrelated groups of people, with or without independent bathroom, cooking or dining facilities, except any building classified under Occupancy C or D. This Occupancy shall be subdivided as follows:

2.1.5.1 Single Family Dwelling (A1)

These shall include any building, row type or semi-detached or detached from neighboring buildings by distances required by this Code and having independent access to the plot, which is used as private dwelling by members of a single family.

2.1.5.2 Two Family Dwelling (A2)

These shall include any building, row type or semi-detached or detached from neighboring buildings by distances required by this Code and having shared or independent access for two families and having facilities for living, cooking and bathroom facilities independent of each other.

2.1.5.3 Flats or Apartments (A3)

These shall include any building or portion thereof which is provided for more than two families, having facilities for living, cooking and bathroom facilities independent of each other.

2.1.5.4 Mess, Boarding Houses, Dormitories and Hostels (A4)

These shall include any building or portion thereof in which sleeping, living accommodations and bathroom are provided for groups of related or unrelated persons, with or without common dining and facilities, and with common cooking under single management control or with individual or group cooking facilities.

2.1.5.5 Hotels and Lodging Houses (A5)

These shall include any building, a portion thereof or group of buildings under single management, in which sleeping, living accommodation and bathroom facilities are provided with or without dining facilities but without cooking facilities for adult individuals, is provided for hire on transient or permanent basis.

2.1.6 Occupancy B: Educational Facilities

This occupancy type shall include any building or portion thereof in which education, training and care are provided to children or adults. This Occupancy shall be subdivided as follows:

2.1.6.1 Educational Facilities up to Higher Secondary Level (B1)

These shall include any building or portion thereof used for purposes involving assembly for instruction, education and recreation of more than six persons on regular basis to fulfil the requirement of an academic curriculum approved by the Government up to Higher Secondary (12th Grade), and which is not covered by occupancy I.

2.1.6.2 Facilities for Training and for Above-Secondary Level (B2)

These shall include any building or portion thereof used for purposes involving assembly for instruction, education, training and recreation of more than six persons, and which is not covered by occupancy I and B1.

2.1.6.3 Pre-School Facilities (B3)

These shall include any building or portion thereof used for purposes involving care, recreation and education of children more than six in number, who have not yet reached the age to attend the school.

2.1.7 Occupancy C: Institution for Care

Buildings classified under this occupancy shall include those used for purposes of institutional care of the occupants, such as detention for correctional or penal purposes, medical or nursing care of persons suffering from illness or infirmity due to mental condition, or accommodation of children or minor, where the personal liberty of the inmate is restricted. These buildings shall ordinarily provide accommodation for sleeping, dining and other provisions approved by the authority for the occupants. This occupancy shall be subdivided as follows:

2.1.7.1 Institution for Care of Children (C1)

These shall include any building or portion thereof or group of buildings under single management used as an institution for the full time care of children or minor, each providing accommodation for sleeping, dining and other provisions approved by the authority for more than six children.

2.1.7.2 Custodial Institution for Physically Capable Adults (C2)

These shall include any building or portion thereof or group of buildings under single management used for purposes of full time care and custody of adult or mentally disabled persons but physically capable of responding to emergency.

2.1.7.3 Custodial Institution for the Incapable Adults (C3)

These shall include any building or portion thereof or group of buildings under single management used for purposes of full time care and custody of persons physically or mentally incapable of responding to emergency.

2.1.7.4 Penal and Mental Institution for Children (C4)

These shall include any building or portion thereof or group of buildings under single management used for housing children under restraint, or who are detained for penal and corrective purposes, in which personal liberty of the inmates is restricted.

2.1.7.5 Penal and Mental Institution for Adults (C5)

These shall include any building or portion thereof or group of buildings under single management used for housing persons under restraint, or who are detained for penal and corrective purposes, in which personal liberty of the inmates is restricted.

2.1.8 Occupancy D: Health Care Facilities

Buildings under this Occupancy group shall include those used for purposes of providing medical care, diagnostic facilities and treatment to persons suffering from physical discomfort, in which sleeping accommodation may or may not be provided. This Occupancy shall be subdivided as follows:

2.1.8.1 Normal Medical Facilities (D1)

These shall include any building or portion thereof or group of buildings under single management in which essential medical facilities having surgery, emergency and casualty treatment facilities, general or specialized medical and other treatment are provided to persons suffering from physical discomfort.

2.1.8.2 Emergency Medical Facilities (D2)

These shall include any building or portion thereof used for purposes of providing essential medical facilities having surgery, emergency, casualty treatment facilities, general or specialized medical and other treatment is provided to persons suffering from physical discomfort. This Type shall be equipped and designated to handle post disaster emergency, by construction it is required to remain operational during and after disasters, built as a part of disaster preparedness program.

2.1.9 Occupancy E: Business

These shall include any building or portion thereof which is used for any business transaction other than mercantile. This Occupancy shall be subdivided as follows:

2.1.9.1 Office (E1)

These shall include any building or part thereof which is used for paper works, documentations, only display of samples of Products but not for direct sale, maintaining accounts and records for administrative or consulting services, banking or activities for business purposes and professional training.

2.1.9.2 Research and Testing Laboratories (E2)

These shall include any building or portion thereof which is used as research establishment and/or test laboratory involving hazardous materials within the limit of exempted quantity permitted in this Code.

2.1.9.3 Essential Services (E3)

These shall include any building or portion thereof used for purposes of providing emergency services and utilities which are required to remain operational during and after a disaster or other emergency situations.

2.1.10 Occupancy F: Mercantile

This occupancy type shall include any building or portion thereof or group of buildings which is used for display and sale of merchandises. This Occupancy shall be subdivided as follows:

2.1.10.1 Small Shops and Market (F1)

These shall include any building or portion thereof with an area divided or undivided not exceeding 300 m², used for purposes of display and sale of merchandise, either wholesale or retail, with or without incidental storage and service facilities.

2.1.10.2 Large Shops and Market (F2)

These shall include any building or portion thereof with an area divided or undivided more than 300 m² used for purposes of display and sale of merchandise, either wholesale or retail, with or without incidental storage and service facilities.

2.1.10.3 Refueling Station (F3)

These shall include any building or portion thereof used for providing refueling and maintenance without repair services for automobiles which is moderately hazardous in nature.

2.1.11 Occupancy G: Industrial Buildings

Buildings under this Occupancy shall be subdivided on the basis of hazard potential of the contents and the processes of the industry. The hazard shall generally mean the relative danger of the start of fire and the rapidity of its spread, the danger of smoke and gases generated that pose a potential threat to the safety of the occupants of the building. Unless areas with different degrees of hazard are effectively segregated and separated in accordance with the provisions of this Code, the most hazardous area in a building shall govern its classification. This occupancy shall also include facilities for public utility services at the producer or distributor's end that deals with generation and distribution of utility facilities. Any such building or portion thereof, which is not using hazardous material quantified and categorized in occupancy group J, shall be subdivided as follows:

2.1.11.1 Low Hazard Industry (G1)

These shall include any industrial building in which the contents are of such low combustibility and the processes conducted therein are of such low hazardous nature that danger of self-ignition and self-propagation of fire is nonexistent, the only danger being an onset of fire from external sources with the resulting danger to life and property.

2.1.11.2 Moderate Hazard Industry (G2)

These shall include any industrial building in which the contents are moderately combustible and the industrial processes conducted therein are liable to give rise to a fire which will spread with moderate rapidity, giving off considerable smoke.

2.1.12 Occupancy H: Storage Buildings

Buildings under this Occupancy group shall include any building or portion thereof used primarily for storage or sheltering of goods, wares, merchandises, vehicles or animals. Any such building or portion thereof, which is not used for storing hazardous material quantified and categorized in occupancy group J, shall be subdivided as follows:

2.1.12.1 Low Fire-risk Storage (H1)

These shall include any building or portion thereof which is used for storage of materials or other contents which do not constitute the danger of self-ignition, and in the event of fire the rate of burning shall be less than moderate rapidity.

2.1.12.2 Moderate Fire-risk Storage (H2)

These shall include any building or portion thereof which is used for storage of materials which do not constitute the danger of self-ignition but which in the event of fire will burn with moderate rapidity.

Items which shall be deemed to render a building hazardous are specified in Sec 2.14.3 along with the exempted amount for each item.

2.1.13 Occupancy I: Assembly

Buildings under this Occupancy group shall include any building or portion thereof in which groups of people congregate or assemble for recreation, amusement, social, religious, political, cultural, travel and similar purposes. This Occupancy shall be subdivided as follows:

2.1.13.1 Large Assembly with Fixed Seats (I1)

This occupancy shall include a building or a portion thereof for assembly in a space provided with fixed seats for 1000 or more persons. Assembly buildings under this subdivision may be for theatrical, operatic performances or cinema projection having or not a raised stage, proscenium curtains, scenery loft or projection screen, lighting equipment, projection booth and necessary theatrical and mechanical equipment.

2.1.13.2 Small Assembly with Fixed Seats (I2)

This occupancy type shall include any building or portion thereof primarily meant for use as described for buildings under Occupancy I1, but with fixed seats for less than 1000 persons in a space. These assembly buildings may or may not be provided with a legitimate theatrical stage or related accessories or equipment.

2.1.13.3 Large Assembly without Fixed Seats (I3)

This occupancy type shall include any building or portion thereof for assembly in a space, in which there are no fixed seats, which may or may not be provided with a legitimate stage or theatrical accessories, and which has accommodation for 300 or more persons.

2.1.13.4 Small Assembly without Fixed Seats (I4)

This occupancy type shall include any building or portion thereof primarily intended for use as described in Occupancy I3, but with accommodation for less than 300 persons in a space.

2.1.13.5 Sports Facilities (I5)

This occupancy type shall include any building or portion thereof meant for assembly of spectators for recreational and amusement purpose mainly related to sports.

2.1.14 Occupancy J: Hazardous Buildings

Any Building or portion thereof used as storage, industrial, research and other facilities dealing with hazardous material in excess of exempted quantity defined in the Table 3.2.5 or any micro-biological facilities shall be categorized in this Occupancy group.

Definition of hazard and the amount of such materials which shall be deemed to render a building hazardous are set forth in Sec 2.14.3. This Occupancy shall be subdivided as follows:

2.1.14.1 Explosion Hazard Buildings (J1)

These shall include any building or portion thereof which is used for storage, handling, processing or manufacture of explosive materials and products that have explosion hazard.

2.1.14.2 Chemical Hazard Buildings (J2)

These shall include any building or portion thereof which is used for storage, handling, processing or manufacture of materials and products that are highly corrosive, toxic, poisonous and physically harmful including corrosive and toxic alkalis, acid or other liquids or chemicals, producing flame, fumes, radiation, and explosive, poisonous, irritant and corrosive gases.

2.1.14.3 Biological Hazard Buildings (J3)

These shall include any building or portion thereof which is used for storage, handling, processing or manufacture of materials and products that use biological processes and in which the risk of harmful biological threat to the occupants exist.

2.1.14.4 Radiation Hazard Buildings (J4)

These shall include any building or portion thereof which is used for storage, handling, processing or manufacture of materials and products that use nuclear and radioactive processes and in which the risk of radioactive contamination exists.

2.1.15 Occupancy K: Garage

These occupancy types shall include any building or portion thereof used one or more vehicles having containers of flammable liquid or compressed gas or carrying power or combination of any of these as a supply source for self-propelling are kept for use, sale, rental purpose, storage, repair, exhibition and all those floors of a building or portion thereof in which such vehicles are not separated by suitable cutoff to prevent fire spreading.

2.1.15.1 Parking Garage (K1)

This occupancy type shall include any building or portion thereof used solely for parking Motor Vehicles for a limited period of time.

2.1.15.2 Private Garage (K2)

This occupancy type shall include any building or portion thereof used as store of owner's or tenant's Motor Vehicles for private use for unlimited period of time.

2.1.15.3 Repair Garage and Showrooms (K3)

This occupancy type shall include any building or portion thereof wherein repair of electrical or mechanical system or denting or painting works of body is performed on any type of vehicles and includes associated floor spaces used as office, showrooms, incidental store and parking.

2.1.16 Occupancy L: Utility

This occupancy type shall include any building or portion thereof used to install any type of equipment to provide support service to any building or portion thereof or group of buildings of all occupancy groups and with special provisions for occupancy J.

This shall also include all public and private utility facilities of the consumer's end that are located within the consumer's site and all installations are required special care to ensure life and property safety as per provisions of this Code.

2.1.17 Occupancy M: Miscellaneous

Buildings under this Occupancy group shall include special buildings not covered in other Occupancy groups. These Occupancies shall be subdivided as follows:

2.1.17.1 Special Structure (M1)

Any building or structure which is neither listed in the A-Z list nor covered in any occupancy group provided in this Code but unique in character may be categorized in this occupancy by the Board of Appeals. Each and every individual M1 Structure shall be complied with NFPA or equivalent standards for the life and fire safety.

2.1.17.2 Fences, Tanks and Towers (M2)

These shall include fences and boundary walls over 1.5 m high, standalone structures for gravity water tank and towers for telecommunication, power distribution, air-traffic control terminal or observation towers.

2.2 Change of Use

2.2.1 Without prior permission from the Authorities having jurisdiction no change shall be made in the type of occupancy or use of any building that would place it in a different occupancy group or in a different subdivision of the same occupancy group. Such changes shall be permitted only when the land use and the building complied with the provisions of this Code and the laws of the land for such group of Occupancy.

2.3 Mixed Occupancy

2.3.1 The following occupancies shall not be required to designate as a separated occupancy classification from uses to which they are accessory any occupancy Group other than Occupancy Group J

- (a) Assembly rooms having a floor area not more than 75 m².
- (b) The administrative and clerical offices and similar offices not exceeding 25 Percent of the floor area of the major occupancy and not related to Hazardous Buildings as defined in Occupancy J.
- (c) Administrative offices, gift shops and other similar uses in Occupancy A provided the uses do not exceed 10 Percent of the floor area of the major occupancy.
- (d) Kitchens associated with a dining area.
- (e) Carports having at least two sides entirely open associated with Occupancy A.

2.3.2 Forms of Occupancy Separations

A building is permitted to have multiple occupancy type, each type of occupancy shall be in groups, which may have combination of different occupancies and shall be separated horizontally or vertically or both accordingly as specified in the Table 3.2.1.

2.3.3 Types of Occupancy Separation

The occupancy separations shall be classified as follows:

- (a) Four Hour Fire Resistive: The four hour fire resistive separation wall or slab shall have no unprotected openings therein and shall provide a fire resistance for at least four hour.
- (b) Three Hour Fire Resistive: The three hour fire resistive separation wall or slab shall provide a fire resistance of not less than three hour. The total width of all openings in separation wall of any one storey shall not exceed 25 Percent of the length of that wall in that storey and no single opening shall have an area greater than 12 m². The openings shall be protected with a fire resistance assembly doors or windows providing fire resistance of at least three hour.
- (c) In case of a floor slab having three hour fire resistance rating, the openings on floor slab shall be protected by vertical enclosures extended above and below such floor openings. The walls of such vertical enclosures shall be at least two hour of fire resistance. All openings in such enclosures shall be protected with fire assembly door or window having fire resistance rating of at least one and one-half hour.
- (d) Two Hour Fire Resistive: The two hour fire resistive separation shall be of a construction having a fire resistance rating of not less than two hour. All openings in such separations shall be protected with a fire assembly door or window of a fire protection rating of at least one and one-half hour.
- (e) One Hour Fire Resistive: The one hour fire resistive separation shall be of at least one hour fire protection construction. All openings in such separations shall be protected with a fire protection assembly door or window of at least one-half hour fire resistance.

2.4.1.2 Fire separation distance shall be measured from the face of peripheral wall of a building to the adjacent property line. For the purpose of this Section, if a public road adjoining all along a property line shall get the benefit of half of Road width as a part of Fire separation distance. For two or more buildings on the same plot, distances of imaginary lines equidistant from all side of buildings shall be considered as the required fire separation distances.

2.4.1.3 The exterior walls of a building shall have a fire resistance and opening protection as specified in Tables 3.3.1 (a), 3.3.1 (b) and 3.2.3.

2.4.1.4 Any outward projected elements from the peripheral wall of a building line shall be limited to the sunshade line.

2.4.1.5 When openings in exterior walls are required to be protected due to distance from the property line, the aggregate area of such openings shall not exceed 50 Percent of the total area of the wall in each storey.

2.4.1.6 Dwellings separation walls in semi-detached or row type development shall comply with Sec 2.4.3.

2.4.2 Allowable Floor Areas

2.4.2.1 The total area of the building shall comply with Sec 1.8.3 Chapter 1 of this Part.

2.4.2.2 The floor area of the mezzanines shall be included in the area of the respective main floor.

2.4.2.3 Floor area calculation shall be divided in to two: (a) All Floor areas at and above the formation level which shall be generally included in the FAR calculation. (b) Floor areas below the formation level shall generally be excluded in FAR calculation provided the Occupancy classifications remain within Utility or Private Garages.

Table 3.2.2: Fire Resistance Ratings in Hours of Exterior Walls for Various Occupancy Groups

Fire Separation Distance	Occupancy			
	A1, A2, K2, M2	A3, A4, A5, B,C, D, E1, F1, F2, G1, I	E2, F3, F4, E3, G2, H1	H2, J
Up to 1.5 m	1	2	3	4
Greater than 1.5 m and up to 3 m	N	1	2	3
Greater than 3 m and up to 4.5 m	N	N	1	2
Greater than 4.5 m and up to 9 m	N	N	N	1
Greater than 9 m	N	N	N	N

N= No requirements

Table 3.2.3: Requirements for Opening Protection Assembly Based on Fire Resistance Rating of Exterior Walls

Fire Resistance Ratings of Exterior Walls (in hours)	Fire Resistance Ratings for Opening Assembly (in hours)
4	Not permitted
3	3.0
2	1.5
1	0.5
N	No requirements

2.4.3 Permitted Types of Construction

2.4.3.1 The types of construction for any occupancy shall conform to the specifications set in Table 3.2.4.

2.4.3.2 Common walls in semi-detached or row type development shall not have any unprotected openings and shall be Type I-A construction and all such wall shall comply with requirements of Party wall or Fire wall or Separation wall.

2.4.3.3 Ground floor or basement of a building used for car parking and utilities within the barriers by at least three hour fire resistive construction shall be considered as non-separated occupancy provided the building accommodates one or more of the following occupancies:

- (i) A3, A5
- (ii) E1, F1, F2
- (iii) I2, I3, I4

2.4.3.4 Entry lobbies, mechanical and electrical rooms and other similar uses incidental to the operation of the building may be provided in the car parking floors provided that the total area of such uses remains within $\frac{1}{3}$ (one third) of the parking floor area.

Table 3.2.4: Permitted Types of Construction and Fire Zones for Various Occupancy Groups

Occupancy	Permitted Types of Construction	Fire Zones
A B C D E1 F1,F2 I K1, K2, M2	Group I and Group II*	1
E2, E3, F3, K3, M1 G H	Group I or Group II*	2
J	Group I	3

*Fire resistance rating of a building shall be credited in case of the mixed type of construction on the basis of lower rated construction elements among the same group or same type used thereof.

2.4.4 General Provision for High-Rise Buildings

For the purpose of this Code, a building of any class of Occupancy will be considered as high-rise when it has floors used for human occupancy located more than 33 m from ground level or the lowest level of fire department vehicle access. The provisions of Sec 2.9.6 shall be applicable to all such buildings.

2.4.4.1 Maintenance and inspection

All fire protection systems shall be maintained and inspected on a regular basis to keep them in operative condition. The maintenance inspection shall be performed quarterly.

All plumbing installations shall be maintained and inspected periodically to keep them in operative conditions.

2.4.4.2 Type of construction

All high-rise buildings shall be of Type I-A or I-B construction.

2.4.4.3 Fire detection, alarm, evacuation and extinguishment system

All high-rise buildings shall conform to regulations set forth in Part 4 of this Code

2.4.5 Helipads

2.4.5.1 General

Helipads on the roof top of a building or other locations shall be constructed in accordance with this Section.

2.4.5.2 Size

The minimum dimension of the landing area for helicopters weighing less than 1600 kg shall be 6 m × 6 m. There shall be an average clearance of 4 m surrounding and at the level of the landing area which shall not be less than 2 m at any point.

2.4.5.3 Construction

Helicopter landing areas and supports shall be constructed with non-combustible material.

2.4.5.4 Aviation approval

Before helipads start operating, formal approval shall be obtained from the civil aviation authority.

2.4.6 Universal Accessibility

2.4.6.1 All Building (except Occupancies G, H, M and J) shall have universal accessibility as per provisions of this Code.

2.4.6.2 Buildings have universal accessibility shall have accessible egress system.

2.5 Requirements For Occupancy A- Residential Buildings

Buildings shall be classified as Occupancy A in accordance with Sec 2.1.5.

2.5.1 Construction, Height and Allowable Area

2.5.1.1 Buildings or parts thereof classified as Occupancy A shall be limited to the type of construction set forth in Table 3.2.4 and shall not exceed in area or height as specified in Sections 1.8 and 2.4.2 of this Part.

2.5.1.2 Walls and floors separating dwelling units in the same building shall not be less than Type I-D construction.

2.5.1.3 Storage or laundry rooms in Occupancy A2, A3, A4 or A5 that are used in common by the occupants shall be at least Type I-D construction.

2.5.1.4 When a basement or a ground floor of a building of Occupancy A3 or A5 is used for parking or storage of private cars of the occupants, the parking floor shall be of at least Type I-B construction.

2.5.1.5 When the basement or ground floor of a building of Occupancy A is used wholly or partly for generator or electrical substation, the walls and floors surrounding such use shall be of at least Type I-B construction.

2.5.2 Location on Property

Buildings of Occupancy A shall comply with the requirements for location on property and fire resistive exterior walls and openings as specified in this Code.

2.5.3 Access and Exit Facilities and Egress System

2.5.3.1 Facilities for access and exit and egress or escape shall comply with the provisions set forth in this Code.

2.5.3.2 Every sleeping room in ground, first and second floors shall have at least one operable window or door for emergency escape which shall open directly into the exterior or an interior courtyard. The units shall be operable from the inside without the use of any tool to provide a minimum clear opening of 500 mm width by 600 mm height with a maximum sill height of 1 m above the floor.

2.5.4 Lighting and Ventilation

All buildings or part of a building classified as Occupancy A shall conform to the provisions of Part 3, and Chapters 1 and 3 of Part 8.

2.5.5 Sanitation

Sanitation facilities provided in all Occupancy A buildings shall conform to this Part and Chapter 7 Part 8.

2.5.6 Minimum Dimension of Habitable and Non-habitable Rooms

The minimum dimensions of habitable and non-habitable rooms are specified in Sec 1.12.2 Chapter 1 Part 3.

2.5.7 Fire detection, Alarm, Evacuation and Extinguishment

All buildings shall conform to regulations set forth in Part 4 of this Code.

2.5.8 Shaft and Exit Enclosure

Elevator shafts, vent shafts and other vertical openings shall be enclosed conforming to the provisions of Tables 3.3.1 (a) and (b). Exit requirements shall comply with Part 4 of this Code.

2.6 Requirements For Occupancy B - Educational Buildings

Buildings shall be classified as Occupancy B in accordance with Sec 2.1.6.

2.6.1 Construction, Height and Allowable Area

Buildings or parts of buildings classified as Occupancy B shall be limited to type of construction set forth in Table 3.2.4 and comply with the provisions of Sections 1.8 and 2.4.2 of this Part to meet the requirements of height and area limitations.

2.6.1.1 Rooms or groups of rooms sharing a common space where flammable liquids, combustible dust or hazardous materials are used, stored, developed or handled in an amount exceeding that specified in Sec 2.14.3 shall be classified as Occupancy J. Such rooms or groups of rooms shall comply with the requirements of fire protection as specified in Part 4, Chapters 4 and 5.

2.6.1.2 Rooms or groups of rooms, sharing a common space or having separate spaces, served by a common corridor or passage with less than 20 percent outdoor opening of wall in a building of height 11 m or less, or three storeys or less, need not be provided with smoke detectors and standpipe or sprinkler system for fire protection provided it conforms with the access and exit requirements specified in Part 3, Chapter 1, Sec 1.6 and Part 4, Chapters 4 and 5.

2.6.1.3 Buildings of Occupancy B situated outside the jurisdiction of any municipality shall have a construction of at least two hours fire resistance.

2.6.2 Location on Property

Buildings of Occupancy B shall comply with the requirements for location on property and fire resistive exterior walls and openings as specified in Sec 2.4.1.

2.6.3 Access and Exit Facilities and Egress System

Facilities for access and exit and Egress system shall comply with the provisions set forth in Sec 1.6, Chapter 1 Part 3 and Chapter 3 Part 4.

2.6.4 Lighting, Ventilation and Sanitation

Lighting, ventilation and sanitation facilities provided in Occupancy Group B buildings shall conform to Sec 1.16, Chapter 1 Part 3 and Chapters 1 and 3 Part 8.

2.6.5 Minimum Dimensions of Class Rooms, Common Toilets and Staircases

The dimension of a class room shall be not less than 4 m on any side and shall have an area of not less than 0.75m² per student. Other provisions for minimum dimensions shall comply with the requirements set forth in Sec 1.8 of Chapter 1 Part 3.

2.6.6 Shaft and Exit Enclosure

Elevator shafts, vent shafts and other vertical openings shall be enclosed conforming to the provisions of Tables 3.3.1 (a) and (b). Exit requirements shall comply with Chapter 3 Part 4.

2.6.7 Fire Detection, Alarm, Evacuation and Extinguishment System

All buildings shall conform to regulations set forth in Part 4 of this Code.

2.7 Requirements For Occupancy C- Institutional Buildings

Buildings shall be classified as Occupancy C in accordance with Sec 2.1.7.

2.7.1 Construction, Height and Allowable Area

The buildings or parts thereof classified as Occupancy C shall be limited to the type of construction set forth in Table 3.2.4 and shall comply with the provisions of Sec 1.8 Chapter 1 Part 3 and Sec 2.4.2 to meet the requirements of height and area limitations.

2.7.2 Location on Property

Buildings of Occupancy C shall comply with the requirements for location on property and fire resistive exterior walls and openings as specified in Sec 2.4.1.

2.7.3 Access and Exit Facilities and Egress System

Facilities for access and exit and egress system shall comply with the provisions set forth in Sec 1.6, Chapter 1 Part 3 and Chapter 3 Part 4.

2.7.4 Lighting, Ventilation and Sanitation

All buildings or part of a building classified as Occupancy C shall conform to the provisions of Sec 1.16, Chapter 1 Part 3 and Chapters 1 and 3, Part 8.

2.7.5 Shaft and Enclosure

Elevator shafts, vent shafts and other vertical openings shall be enclosed conforming to the provisions of Tables 3.3.1 (a) and (b). Exit requirements shall comply with Chapter 3, Part 4.

2.7.6 Fire Detection, Alarm, Evacuation and Extinguishment System

All buildings shall conform to regulations set forth in Part 4 of this Code.

2.8 Requirements For Occupancy D–Health Care Facilities

Buildings shall be classified as Occupancy D in accordance with Sec 2.1.8.

2.8.1 Construction, Height and Allowable Area

The buildings or parts thereof classified as Occupancy D shall be limited to the type of construction set forth in Table 3.2.4 and shall comply with the provisions of Sec 1.8 Chapter 1 Part 3 and Sec 2.4.2 to meet the requirements of height and area limitations.

2.8.2 Location on Property

Buildings of Occupancy D shall comply with the requirements for location on property and fire resistive exterior walls and openings as specified in Sec 2.4.1.

2.8.3 Access and Exit Facilities and Egress System

Facilities for access and exit and egress system shall comply with the provisions set forth in Sec 1.6 Chapter 1, Part 3 and Chapter 3 of Part 4.

2.8.4 Lighting, Ventilation and Sanitation

All buildings or part of a building classified as Occupancy D shall conform to the provisions of Sec 1.16 Chapter 1 Part 3, Chapters 1 and 3 of Part 8.

2.8.5 Shaft and Enclosure

Elevator shafts, vent shafts and other vertical openings shall be enclosed conforming to the provisions of Tables 3.3.1 (a) and (b). Exit requirements shall comply with Chapter 3 of Part 4.

2.8.6 Fire Detection, Alarm, Evacuation and Extinguishment System

All buildings shall conform to regulations set forth in Part 4 of this Code.

2.9 Requirements For Occupancy E–Business

Buildings shall be classified as Occupancy E in accordance with Sec 2.1.9.

2.9.1 Construction, Height and Allowable Area

The buildings or parts thereof classified as Occupancy E shall be limited to the type of construction set forth in Table 3.2.4 and shall comply with the provisions of Sec 1.8 Chapter 1 Part 3 and Sec 2.4.2 to meet the requirements of height and area limitations.

2.9.2 Location on Property

Buildings of Occupancy E shall comply with the requirements for location on property and fire resistive exterior walls and openings as specified in Sec 2.4.1.

2.9.3 Access and Exit Facilities and Egress System

Facilities for access and exit and egress system shall comply with the provisions set forth in Sec 1.6 Chapter 1 Part 3, Chapter 3 of Part 4.

2.9.4 Lighting, Ventilation and Sanitation

All buildings or part of a building classified as Occupancy E shall conform to the provisions of Sec 1.16 Chapter 1 Part 3, Chapters 1 and 3 of Part 8.

2.9.5 Shaft and Enclosure

Elevator shafts, vent shafts and other vertical openings shall be enclosed conforming to the provisions of Tables 3.3.1 (a) and (b). Exit requirements shall comply with Chapter 3 of Part 4.

2.9.6 Fire Detection, Alarm, Evacuation and Extinguishment System

All buildings shall conform to regulations set forth in Part 4 of this Code.

2.10 Requirements For Occupancy F–Mercantile Buildings

Buildings shall be classified as Occupancy F in accordance with Sec 2.1.10.

2.10.1 Construction, Height and Allowable Area

The buildings or parts thereof classified as Occupancy F shall be limited to the type of construction set forth in Table 3.2.4 and shall comply with the provisions of Sec 1.8, Chapter 1 of Part 3 and Sec 2.4.2 to meet the requirements and limitations of height and area.

2.10.2 Location on Property

Buildings of Occupancy F shall comply with the requirements for location on property and fire resistive exterior walls and openings as specified in Sec 2.4.1.

2.10.3 Access and Exit Facilities and Emergency Escapes

Facilities for access and exit and emergency escape shall comply with the provisions set forth in Sec 1.6 Chapter 1 Part 3 and Chapter 3 Part 4.

2.10.4 Lighting, Ventilation and Sanitation

All buildings or part of a building classified as Occupancy F shall conform to the provisions of Sec 1.16 Chapter 1 Part 3, Chapters 1 and 3, Part 8.

2.10.5 Shaft and Enclosure

Elevator shafts, vent shafts and other vertical openings shall be enclosed conforming to the provisions of Tables 3.3.1 (a) and (b). Exit requirements shall comply with Chapter 3, Part 4.

2.10.6 Fire Detection, Alarm, Evacuation and Extinguishment System

All buildings shall conform to regulations set forth in Part 4 of this Code.

2.10.7 Special Hazards

Installations which are discharging exhaust, heating apparatus, boiler and central heating/air-conditioning plant shall conform to the provisions of this Code as specified in this Code.

2.11 Requirements For Occupancy G—Industrial Buildings

Buildings shall be classified as Occupancy G in accordance with Sec 2.1.11. A non-exhaustive and indicative list of low hazard and moderate hazard industrial uses are listed in A to Z list. Storage and use of hazardous materials shall not exceed the exempt amount specified in Sec 2.14.3.

2.11.1 Construction, Height and Allowable Area

The buildings or parts thereof classified as Occupancy G shall be limited to the type of construction set forth in Table 3.2.4 and shall comply with the provisions of Sec 1.8 of Chapter 1, Part 3 and Sec 2.4.2 to meet the requirements and limitations of height and floor area.

The ceiling height of the production area, shall conform to the minimum volume required per workers as specified by the Bangladesh Labor Act, 2006 and other laws of the land. In any case the ceiling height and the head room clearance of a production floor shall not be less than 3.3 meter and 2.286 meter respectively.

2.11.2 Location on Property

Buildings of Occupancy G shall comply with the requirements for location on property and fire resistive exterior walls and openings as specified in Sec 2.4.1.

2.11.3 Access and Exit Facilities and Egress System

Facilities for access and exit and emergency escape shall comply with the provisions set forth in Sec 1.6 Chapter 1, Part 3 and Chapter 3, Part 4.

2.11.4 Lighting, Ventilation and Sanitation

All buildings or part of a building classified as Occupancy G shall conform to the provisions of Sec 1.16 Chapter 1, Part 3 and Chapters 1 and 3, Part 8. Industrial buildings having roof opening for day lighting and natural ventilation shall comply with the following requirements:

- (a) The aggregate opening in roof and external windows shall not be less than 10 Percent of the floor area.
- (b) For natural ventilation by means of exterior window openings, the operable window area shall not be less than 5 Percent of the total floor area.

Exception:

Industrial buildings wherein artificial lighting and mechanically operated ventilation systems of approved quality are installed, need not be provided with natural ventilation or natural lighting.

2.11.5 Shaft and Enclosure

Elevator shafts, vent shafts and other vertical openings shall be enclosed conforming to the provisions of Tables 3.3.1 (a) and (b). Exit requirements shall comply with Chapter 3, Part 4.

2.11.6 Fire Detection, Alarm, Evacuation and Extinguishment System

All buildings shall conform to regulations set forth in Part 4 of this Code.

2.11.7 Special Hazards

Chimneys, vents and ventilation ducts shall be constructed with noncombustible materials. Every boiler, central heating plants, electrical rooms, or hot water supply boiler shall be separated from the rest of the occupancy or use by not less than two hour fire resistive construction.

2.12 Requirements For Occupancy H–Storage Buildings

Buildings shall be classified as Occupancy H in accordance with Sec 2.1.12.

2.12.1 Construction, Height and Allowable Area

The buildings or parts thereof classified as Occupancy H shall be limited to the type of construction set forth in Table 3.2.4 and shall comply with the provisions of Sec 1.8 of Chapter 1, Part 3 and Sec 2.4.2 to meet the requirements of height and area limitations.

2.12.2 Location on Property

The location on property for Occupancy H shall conform to Sec 2.4.1.

2.12.3 Access and Exit Facilities and Egress System

Facilities for access and exit and egress system shall comply with the provisions set forth in Sec 1.6 of Chapter 1, Part 3 and Chapter 3, Part 4.

2.12.4 Lighting, Ventilation and Sanitation

All buildings or part of a building classified as Occupancy H shall conform to the provisions of Sec 1.16 of Chapter 1 Part 3, Chapters 1 and 3, Part 8.

2.12.4.1 Special provision

The provisions of Sec 1.16, does not apply to non-habitable spaces of H1 and H2 occupancies unless otherwise required by this Code. Ventilators of size not less than 0.25 m² shall be provided where suitable 0.30 m above the floor level for floor level ventilators and 0.30 m below the roof level for roof level ventilators. There shall be one floor level ventilator and one roof level ventilator for every 0.25 m² of the floor area. Mechanized ventilation system of approved quality shall be installed where required.

2.12.4.2 Though inhabitable, the minimum air quality of such indoor spaces shall be maintained in a way that it does not pose any health hazard to the occasional users of that space.

2.12.5 Shaft and Enclosure

Elevator shafts, vent shafts and other vertical openings shall be enclosed conforming to the provisions of Tables 3.3.1 (a) and (b). Exit requirements shall comply with Chapter 3, Part 4.

2.12.6 Fire Detection, Alarm, Evacuation and Extinguishment System

All buildings shall conform to regulations set forth in Part 4 of this Code.

2.12.7 Special Hazards

The storage of hazardous materials shall not exceed the exempt amount as specified in Table 3.2.5. The storage of moderate and low hazardous materials shall be separated at least by a two hour fire resistive construction.

2.13 Requirements For Occupancy I–Assembly Buildings

Buildings shall be classified as Occupancy I in accordance with Sec 2.1.13.

2.13.1 Construction, Height and Allowable Area

The buildings or parts thereof classified as Occupancy I shall be limited to the type of construction set forth in Table 3.2.4 and shall comply with the provisions of Sec 1.8 Chapter 1 Part 3 and Sec 2.4.2 to meet the requirements and limitations of height and area.

2.13.2 Location on Property

Buildings of Occupancy I shall comply with the requirements for location on property and fire resistive exterior walls and openings as specified in Sec 2.4.1.

2.13.3 Access and Exit Facilities and Egress System

Facilities for access and exit and Egress system shall comply with the provisions set forth in Sec 1.6 Chapter 1 of Part 3 and Chapter 3 of Part 4 and universally accessibility as per provisions of this Code.

2.13.4 Lighting, Ventilation and Sanitation

All buildings or part of a building classified as Occupancy I shall conform to the provisions of Sec 1.16 Chapter 1 Part 3, Part 3 and Chapters 1 and 3, Part 8.

2.13.5 Shaft and Enclosure

Elevator shafts, vent shafts and other vertical openings shall be enclosed conforming to the provisions of Tables 3.3.1 (a) and (b). Exit requirements shall comply with Chapter 3, Part 4.

2.13.6 Fire Detection, Alarm, Evacuation and Extinguishment System

All buildings shall conform to regulations set forth in Part 4 of this Code.

The specification of this Section shall apply to all parts of buildings and structures that contain stages or platforms and other similar appurtenances as herein defined.

- (a) Stages: A stage is a three side enclosed or partially enclosed portion of a building which is designed or used for presentation of plays or lectures or other entertainment. A stage shall be further classified as legitimate stage, regular stage and thrust stage.
- (b) Stage, Legitimate: A stage wherein curtains, drops, leg drops, scenery, lighting devices or other stage effects are adjustable horizontally or vertically or suspended overhead.
- (c) Stage, Regular: A stage wherein curtains, fixed drops, valances, scenery and other stage effects are suspended and are not adjustable or retractable.
- (d) Stage, Thrust: A stage or platform extended beyond the proscenium line and into the audience.

2.13.6.1 Legitimate Stage

Legitimate stage shall be constructed as specified in Part 4, specifying the type of construction but shall not be less than construction Type I-C. The position of the legitimate stage extending beyond the proscenium opening line shall be permitted to be constructed with two hour fire-resistive materials. The floor of the stage may be constructed with one hour fire rating materials. Thickness of a wooden floor shall not be less than 50 mm.

2.13.6.2 Regular and Thrust Stages

Regular stages and thrust stages shall be constructed by not less than two hour fire resistive materials. Wooden floor when required in a stage shall not be less than 50 mm in thickness with one hour fire resistive rating.

2.13.6.3 Trap doors

All trap doors and any other opening in stage floors shall be equipped with tight fitting solid wood trap doors with thickness not less than 50 mm.

2.13.6.4 Stage rigging loft

The grid iron frame in the loft, housing lighting and audio equipment, all the machinery for flying scenery and fly galleries, along with their installations, shall be constructed of approved noncombustible materials.

2.13.6.5 Foot lights and stage electrical equipment

Foot lights and border lights shall be installed in a protective cover constructed of noncombustible materials.

2.13.6.6 Trim, finish and decorative hangings

All materials used in moulding and decoration around the proscenium shall be of approved noncombustible materials.

2.13.6.7 Proscenium curtain

The proscenium curtain shall be of approved fire retardant material and shall protect against passage of flame and smoke for at least 30 minutes.

2.13.7 Motion Picture Projection Rooms

2.13.7.1 Every projection room shall be constructed in conformity with the construction requirements for the type of the building in which the projection room is located. The wall opening required for projection need not have a fire protection assembly but shall be closed with glass or other approved materials.

2.13.7.2 The floor area of a projection room shall not be less than 8 m² for a single machine. The working space between the machines when more than one machine is used shall not be less than 0.75 m.

2.13.7.3 The height of the projection room shall have a minimum clear space of 2.5 m.

2.13.8 Sports Facilities

2.13.8.1 Vomitors, aisles and exits of seating galleries

Tunnels, aisles and exits of galleries shall be constructed conforming to the following requirements.

- (a) There shall be a minimum of two exits remotely located from each other immediately to the outside for each balcony or tier. There shall be at least three exits when seating capacity exceeds 1000 persons and four exits when it exceeds 4000 persons. For every additional 1000 persons the exit shall be designed to accommodate provision (f) given below.
- (b) There shall be at least 0.6 m² of space per person in the gallery. Minimum width considered for a seat in the gallery shall be 0.45 m.
- (c) There shall be a maximum of 33 seats on each side of any aisle. Minimum width of the main aisles and the secondary aisles shall be 1.0 m and 0.7 m respectively.
- (d) Entrance and exits shall be protected by safety railings.
- (e) Back to back space between two rows of seats shall not be less than 0.80 m.
- (f) The evacuation time in the galleries shall not be more than 10 minutes.
- (g) All tunnels, aisles and exits shall conform to safety guidelines for means of escape set forth in Part 4.
- (h) One percent of the total seat capacity shall have provisions for accommodation with universal accessibility at the approach or exit level.

2.13.8.2 Swimming pools

Any swimming pool used or constructed for exclusive use by Occupancy A1 and is available only to the occupants and private guests shall be classified as a private swimming pool. Any swimming pool other than private swimming pool shall be classified as a public swimming pool. Swimming pools shall be constructed in conformity with the following requirements.

- (a) There shall be at least 1.5 m space between any sides of a swimming pool and a rear or side property line. For street property lines, this distance shall be at least 2.0 m.

- (b) Swimming pools shall be provided with overflow provision to remove scum and other materials from the surface of the water. When water skimmers are used for private pools there shall be one skimming device for each 50 m² of surface area or fraction thereof.
- (c) The overflow gutters shall not be less than 75 mm deep and shall be pitched to slope of one unit vertical to 50 units horizontal (1:50) toward drains.
- (d) Public swimming pools shall be so designed that the pool water turnover is at least once every 8 hours.
- (e) Private swimming pools shall be designed so that there is a pool water turnover at least once every 18 hours.
- (f) Public swimming pools shall be equipped with filters, the capacity of which shall be controlled to filter 140 liters per minute per m² of surface area. Private swimming pool filters shall not filter more than 230 liters per minute per m² of the surface area.
- (g) The pH value of the pool water shall be between 7.0 and 7.5.
- (h) All recirculation systems shall be equipped with an approved hair and lint strainer installed in the system ahead of the pump.
- (i) All swimming pool and equipment shall be designed to be emptied completely of water and the discharged water shall be disposed in an approved manner and shall not create problems in the neighboring property.
- (j) Pumps, filters and other mechanical and electrical equipment shall be placed in enclosed spaces and shall not be accessible to the bathers.
- (k) Used water from the pool when being discarded shall be reused as grey water for the building and its premises as per provision of Appendix G.

2.13.9 Amusement Building Fire Protection System

The fire protection system shall be as per provisions of this Code.

2.14 Requirements For Occupancy J–Hazardous Buildings

Buildings shall be classified as Occupancy J in accordance with Sec 2.1.14.

2.14.1 General

The plans for buildings and structures accommodating Occupancy J shall clearly indicate the type and intended use of materials and its processing or handling methods so as to reflect the nature of use of each portion of such buildings.

2.14.1.1 Occupancy J1

Any building or portion thereof containing any of the following items more than exempted quantity shall be classified as Occupancy J1.

- (a) Combustible dusts and any similar solid material sufficiently comminuted for suspension in still air which, when so suspended, is capable of self-sustained combustion.
- (b) Combustible liquids - Any liquid having a flash point at or above 40°C shall be known as class II and class III liquids. Combustible liquids shall be classified as follows:
 - (i) Liquids having flash point at or above 40°C and below 60°C.
 - (ii) Liquids having flash points at or above 60°C and below 95°C.
- (c) Cryogenic liquids (flammable or oxidizing): Any liquid that has a boiling point below -130°C.
- (d) Flammable Gases: Any gas when mixed with air in a proportion of 13% (by volume) forms a flammable mixture under atmospheric temperature and pressure.
- (e) Flammable Liquids: Any liquid that has a flash point below 40°C and has a net vapour pressure exceeding 275 kPa at 40°C. Flammable liquids shall be known as Class I liquid and shall be further classified as follows:
 - (i) Liquids having flash point below 25°C and having a boiling point below 40°C.
 - (ii) Liquids having flash point below 25°C and having a boiling point at or above 40°C.
 - (iii) Liquids having flash points at or above 25°C and below 40°C.
- (f) Oxidizers class 3: As determined in accordance with NFPA 43A.
- (g) Oxidizing gases: As determined in accordance with NFPA 43C.
- (h) Pyrophoric liquids, solids and gases that will ignite spontaneously in air at a temperature of 55°C or below.
- (i) Unstable (reactive) materials class 3, non-detonable as determined in accordance with NFPA 704.
- (j) Combustible fibers: Includes readily ignitable fibers like cotton, sisal, jute hemp, tow, cocoa fiber, oakum, baled waste, baled waste paper, kapok, hay, straw, excelsior, Spanish moss and other similar materials.

- (k) Flammable solid: Any solid including blasting agent or explosive that is liable to cause fire through absorption of moisture, spontaneous chemical change or retained heat from manufacturing or processing, or which when ignited burns so vigorously and persistently as to create a serious hazard.
- (l) Organic peroxides, Class II and Class III as determined in accordance with NFPA 43B.
- (m) Oxidizers Class I and Class II as determined in accordance with NFPA 43A.
- (n) The bulk storage of unstable (reactive) materials Class 1 and Class 2 as determined in accordance with NFPA 704, water reactive materials, Class 2 and Class 3 which react with water to release a gas that is either flammable or present a health hazard as determined in accordance with NFPA 704.

2.14.1.2 Occupancy J2

Any building or portion thereof containing the following shall be classified as Occupancy J2:

- (a) Corrosives: Any substance that causes visible destruction of or irreversible alteration in living tissues by chemical action at the site of contact.
- (b) Highly toxic materials: The materials falling in this category are as follows:
 - (i) Oral Toxicity: A chemical that has a median lethal dose of 50 mg or less per kg of body weight when administered orally to albino rats weighing between 200 and 300 gm each.
 - (ii) Toxicity of Inhalation: A chemical that has a median lethal concentration in air of 200 ppm or less by volume of gas or vapors, or 2 mg per liter or less of mist, fume or dust, when administered by continuous inhalation for 1 hour (or less if death occurs within 1 hour) to albino rats weighing between 200 and 300 grams each.
 - (iii) Toxicity by Skin Absorption : A chemical that has median lethal dose of 200 mg or less per kg of body weight when administered by continuous contact for 24 hours (or less if death occurs within 24 hours) with the bare skin of albino rabbits weighing between 2 and 3 kg each.

- (iv) Irritants: Any noncorrosive chemical or substance which causes a reversible inflammatory effect on living tissues by chemical action at the site of contact.
 - (v) Radioactive Material: Any material or combination of materials that spontaneously emit ionizing radiation.
 - (vi) Sensitizers: A chemical or substance that causes a substantial proportion of exposed people or animals to develop an allergic reaction in normal tissue after repeated exposure.
- (c) The Occupancy J2 shall also include among others the followings:
- (i) Dry cleaning establishments using flammable solvents.
 - (ii) Explosive manufacturing.
 - (iii) Paint or solvent manufacturing (flammable base).
 - (iv) Pyrexin plastic manufacturing.
 - (v) Sodium nitrate or ammonium nitrate.
 - (vi) Storage of combustible film.

2.14.1.3 Occupancy J3

Any building or portion thereof which is used for storage, handling, processing or manufacture of materials and products that use biological processes and in which the risk of harmful biological threat to the occupants exist, shall comply with the guidelines specified by the Department of Health.

2.14.1.4 Occupancy J4

Any building or portion thereof which is used for storage, handling, processing or manufacture of materials and products that use nuclear and radioactive processes and in which the risk of radioactive contamination exists, shall comply with the guidelines specified by Bangladesh Atomic Energy Commission.

2.14.2 Special Provisions

2.14.2.1 The following shall not be included in Occupancy J but shall be classified in the occupancy group which they most nearly resemble and such classification shall be approved by the Authority:

- (a) All buildings and structures and parts thereof which contain less than the exempt quantities as specified in Table 3.2.5, when such buildings comply with the fire protection provisions of this Code.

- (b) Rooms containing flammable liquid in lightly closed containers of 4 litre capacity or less for retail sales or private use on the premises and in quantities not exceeding 820 litres/m² of room area.
- (c) Retail paint sales rooms with quantities not exceeding 820 litres/m² of room area.
- (d) Closed systems housing flammable or combustible liquids or gases used for the operation of machinery or equipment.
- (e) Cleaning establishments.
- (f) Liquor stores and distributors without bulk storage.
- (g) Tire storage containing less than 10,000 vehicle tires.
- (h) The storage or use of materials for agricultural purposes for use on the premises.
- (i) Pyrophoric solids or liquids not exceeding 3 m³ in storage cabinet located in a building that is equipped throughout with an automatic sprinkler system provided in accordance with the fire protection provisions of this Code.
- (j) Pyrophoric solids or liquids not exceeding 3 kg in storage cabinet located in a building that is provided with an automatic sprinkler system installed in accordance with the fire protection provisions in accordance to Part 4 of this Code.
- (k) Class 2 water reactive materials not exceeding 100 kg in an approved storage cabinet located in a building that is provided with automatic sprinkler installed in accordance with the fire protection provisions in accordance to Part 4 of this Code.

2.14.3 Construction, Height and Allowable Area

2.14.3.1 The buildings or parts thereof classified as Occupancy J shall be limited to the type of construction set forth in Table 3.2.4 and shall comply with the provisions of Sec 1.8 of Chapter 1, Part 3 and Sec 2.4.2 of this Chapter to meet the requirements of height and area limitations.

2.14.3.2 Floors: The floors and spaces containing hazardous materials and in areas where motor vehicles, boats, helicopters or airplanes are stored, repaired or operated shall be of noncombustible, liquid-tight construction.

Exception: In floors and areas where no repair works are carried out may be surfaced or waterproofed with asphaltic paving materials.

2.14.3.3 Spill Control: The floors containing hazardous repair or other works shall be recessed a minimum of 100 mm so as to prevent flow of liquids to adjoining areas.

2.14.3.4 Drainage: The buildings and areas shall be provided with approved drainage system to direct the flow of liquids to an approved location or room or area designed to provide secondary containment of the hazardous materials and fire protection water.

Table 3.2.5(a): Exempted Amount of Hazardous Materials in Terms of Physical Hazard in a Control Area

Sl. No.	Material	Class/State	Maximum Quantities in		
			Storage Limit	Use Closed Systems	Use Open Systems
1	Flammable liquids	Class I-A	115 liters *	115 liters *	38 liters
		Class I-B and Class I-C	454 liters *	454 liters *	115 liters
2	Combustible liquids	Class-II	454 liters*	454 liters*	114 liters
		Class-III-A	1249 liters*	1249 liters*	320 liters
		Class-III-B	49962 liters*	49962 liters*	12490 liters
3	Combination of flammable liquids	Class I-A Class I-B Class I-C	454 liters*	454 liters*	113 liters*
4	Flammable gases	Gaseous	28 m ³ at NTP (Natural Temperature and Pressure)	28 m ³ at NTP (Natural Temperature and Pressure)	Not applicable
		Liquefied	113 liters	113 liters	Not applicable
5	Liquefied flammable	Class I-A	113 liters	113 liters	38 liters
		Class I-B and Class I-C	454 liters	454 liters	113 liters
6	Combustible fibres	Loose	2.832 m ³	2.832 m ³	0.57 m ³
		Baled	28.32 m ³	28.32 m ³	5.7 m ³

Sl. No.	Material	Class/State	Maximum Quantities in		
			Storage Limit	Use Closed Systems	Use Open Systems
7	Flammable solids	Pigs, ingots, heavy castings	454 kg	454 kg	454 kg
		Light castings, light metallic products	57 kg	57 kg	57 kg
		Scraps, shavings, powders, dusts	0.454 kg	0.454 kg	0.454 kg
8	Unstable (reactive) detonable	Class 4	0.454kg or 0.28m ³ (NTP)	0.113 kg or 0.057m ³ (NTP)	0.454kg or 0.28m ³ (NTP)
		Class 3	0.454kg or 0.28m ³ (NTP)	0.113 kg or 0.057m ³ (NTP)	0.454kg or 0.28m ³ (NTP)
9	Unstable (reactive) detonable	Class 4	0.454kg or 0.28m ³ (NTP)	0.113 kg or 0.057m ³ (NTP)	0.454kg or 0.28m ³ (NTP)
		Class 3	2.27 kg or 1.42m ³ (NTP)	0.454kg or 0.2832m ³ (NTP)	0.454kg
		Class 2	22.7kg or 70.8 m ³ (NTP)	22.7kg or 70.8m ³ (NTP)	4.54 kg
		Class 1	Not limited or 21.24m ³ (NTP)	Not limited	Not limited
10	Water-reactive detonable	3	0.454 kg	11.25 kg	11.25 kg
		2	0.454 kg	11.25 kg	11.25 kg
11	Water-reactive non-detonable	3	2.27 kg	2.27 kg	0.454 kg
		2	22.7 kg	22.7 kg	4.54 kg
		1	Not limited	Not limited	Not limited
12	Oxidizing Materials	Class 4	0.454 kg	0.1135kg	0.1135kg
		Class 3	4.54 kg	0.227kg	0.227kg
		Class 2	113 kg	113 kg	113 kg
		Class 1	1816 kg	1816 kg	1816 kg

Sl. No.	Material	Class/State	Maximum Quantities in		
			Storage Limit	Use Closed Systems	Use Open Systems
13	Oxidizing Gas	Gaseous	42.48 m ³ (NTP)	42.48 m ³ (NTP)	Not applicable
		Liquefied	56.78 liters	56.78 liters	Not applicable
14	Pyrophoric Material detonable	Not applicable	0.454 kg or 0.056 m ³ (NTP)	0.056 m ³ (NTP)	0
15	Pyrophoric Material non-detonable	Not applicable	1.8 kg. or 1.4 m ³ (NTP)	0.28m ³ (NTP)	0
16	Explosives**	Division 1.1	0.454 kg	0.1135 kg	0.1135 kg
		Division 1.2	0.454 kg	0.1135 kg	0.1135 kg
		Division 1.3	2.27 kg	0.454 kg	0.454 kg
		Division 1.4	22.7 kg	22.7 kg	Not applicable
		Division 1.4G	56.75 kg	Not applicable	Not applicable
		Division 1.5	0.454 kg	0.1135 kg	0.1135 kg
		Division 1.6	0.454 kg	Not applicable	Not applicable

* The maximum quantities may be increased by 100 percent in areas not accessible to the public in buildings provided with automatic sprinkler system.

** see: Explosive control act.

Table 3.2.5(b): Exempted Amounts of Hazardous Materials in Terms Health Hazard in a Control Area

Material	Class/State	Maximum Quantities in		
		Single Storage	Closed Systems	Open Systems
Corrosive	Not applicable	2270 kg or 1892 liters or 23 m ³ NTP	227kg or 1892 liters or 23 m ³ NTP	454kg or 379 liters
Highly toxic	Not applicable	4.54 kg or 0.57 m ³ NTP	4.54 kg or 0.57 m ³ NTP	1.362 kg
Toxic	Not applicable	227 kg or 23 m ³ NTP	227 kg	56.75 kg

Table 3.2.5(c): Location and Number of Control Areas

Grade Level	Floor Level ¹	Number of Control Areas per Floor ²	Fire Resistance Rating of Barriers in Hours		
			Walls	Floors	Floor Supporting Members
Above	Higher than 9	5	1	2	2
	7-9	5	2	2	2
	6	12.5	2	2	2
	5	12.5	2	2	2
	4	12.5	2	2	2
	3	50	2	1	2
	2	75	3	1	2
	1	100	4	1	2
Below	1	75	3	1	2
	2	50	2	1	2
	Lower than 2	Not Allowed	Not Allowed	Not Allowed	Not applicable
The maximum allowable quantity per control area shown in Table 3.2.5					

2.14.3.5 The drains shall be designed with adequate slope and section to carry the design discharge of the sprinkler system. The material used in the drains shall be suitable for drainage of the storage materials.

2.14.3.6 Separate drainage system shall be designed for materials which react with each other producing undesirable results. They may be combined when they have been provided with approved means of discharge into the public sewer or natural stream or river.

2.14.3.7 Containment: The outflow from the drains shall be directed to a containment system or other area that provide a secondary storage for the hazardous materials and liquids and fire protection water. The containment capacity shall be capable of containing the outflow from the drains for a period of at least one hour.

2.14.3.8 The overflow from secondary containment system shall be directed to a safe location away from the building, adjoining properties and storm drain.

2.14.3.9 If the secondary containment storage area is open to rainfall it shall be designed to accommodate 24 hour rainfall or a continuous rainfall of 100 mm per day.

2.14.3.10 Smoke and Heat Vents: Smoke and heat vents shall be provided in areas or rooms containing hazardous materials exceeding the exempt amount of Table 3.2.5.

2.14.3.11 Standby Power: Standby power shall be provided in the occupancies where Class I, II or III organic peroxides are stored.

2.14.4 Location on Property

The location on property for Occupancy J shall conform to Sec 2.4.1 and Part 4.

2.14.5 Access and Exit Facilities and Emergency Escapes

Facilities for access and exit and emergency escape shall comply with the provisions set forth in Sec 1.6 of Chapter 1, Part 3, and Chapter 3, Part 4.

2.14.6 Lighting and Ventilation

2.14.6.1 All spaces and rooms customarily occupied by human beings shall be provided with natural light by means of exterior glazing with an area of not less than 10 Percent of the floor area. Such rooms and spaces shall be provided with natural ventilation by means of exterior openings with an open able area not less than 5 Percent of the total floor area or artificial light and mechanically operated ventilation system as per provisions of this Code.

2.14.6.2 Ventilation in Hazardous Locations: The rooms, spaces or areas where explosive, corrosive, combustible, flammable or highly toxic dust, mists, fumes, vapors or gases are stored or may be emitted due to the processing, use, handling or storage of materials shall be mechanically ventilated.

2.14.6.3 The mechanical ventilation of all hazardous uses shall be segregated or separated from the ventilation of other areas. The emissions generated at work areas shall be confined to the area in which they are generated and shall be removed or discharged outside the building and preventive measures against back flow of such hazardous fumes or gases inside the building shall be installed.

2.14.6.4 Ventilation of Toilets: Toilets shall be provided with fully openable exterior window of at least 0.3 m² in area or a vertical duct not less than 62500 mm² in cross-section for the first water closet, with additional 31250 mm² for each additional fixture or a mechanically operated exhaust system equipped to provide a complete change of air in every 15 minutes. Such system shall be connected to the outside air and the point of discharge shall be at least 1.0 m away from any other opening into the building.

2.14.6.5 Other requirements of water closets are specified in Sec 1.12.4 Chapter 1, Part 3.

2.14.7 Sanitation

All buildings or part of a building classified as Occupancy J shall conform to the provisions of Sec 1.16 of this Chapter and Part 8 of this Code.

2.14.8 Shaft and Exit Enclosures

Elevator shafts, vent shafts and other vertical openings shall be enclosed conforming to the provisions of Tables 3.3.1 (a) and (b). Exit requirements shall comply with Chapter 3, Part 4.

2.14.9 Fire Detection, Alarm, Evacuation and Extinguishment System

All buildings shall conform to regulations set forth in Part 4 of this Code.

2.14.10 Explosion Control

Explosion control, equivalent protective devices or suppression systems or barricades shall be installed to control or vent the gases resulting from deflagrations of dusts, gases or mists in a room or area, building or other enclosures to minimize structural or mechanical damage.

Walls, floors and roofs separating a use from explosion exposure shall be designed according to the provisions of Chapter 1, Part 6.

Explosion venting shall be designed in exterior walls or roof only. The venting shall be provided to prevent serious structural damage and production of lethal projectiles. The venting design shall recognize the natural characteristics and behaviors of building materials in an explosion. The vents shall be designed to relieve at a maximum internal pressure of 1.0 kPa but not less than the loads required by Chapter 2, Part 6. One or more of the following systems shall be installed to relieve explosion, where applicable:

- (a) Lightweight materials in walls
- (b) Light fastening devices with hatch covers
- (c) Light fastening with outward opening swing doors in exterior walls
- (d) Nonbearing walls with light ties

The venting devices shall discharge vertically or horizontally directly to an unoccupied yard having a width of not less than 16 m on the same plot.

The releasing devices shall be so located that the discharge end shall not be less than 3 m vertically and 6 m horizontally from window openings or exits in the same or adjoining buildings.

2.14.11 Special Hazard

Chimneys, vents and ventilation ducts shall be of noncombustible materials.

All boilers, central heating plants, electrical rooms or hot water supply boiler shall be separated from the rest of the occupancies or uses by not less than 2 hour fire resistive construction.

The devices that generate a spark, flame or glow capable of igniting gasoline shall not be installed or used within 0.5 m of the floor.

Equipment or machinery that produces or emits combustible or explosive dust or fibers shall be provided with an approved dust collecting and exhaust system.

The equipment or systems that are used to collect or process or convey combustible dust or fibers shall be installed with explosion venting or containment system.

2.15 Requirements For Occupancy K–Garage Buildings

Buildings shall be classified as Occupancy K in accordance with Sec 2.1.15.

Exception: Non-separated use mentioned in Sec 2.3.1.

2.15.1 Construction, Height and Allowable Area

The buildings or parts thereof classified as Occupancy K shall be limited to the type of construction set forth in Table 3.2.4 and Sec 2.4.4.2 and shall comply with the other provisions of Sec 1.8 Chapter 1 Part 3, Appendix F and Sec 2.4.2 to meet the requirements and limitations of height and area. With the exceptions mentioned in Sec 2.4.3, all garage floors shall be constructed with not less than 4 hour fire resistance materials.

2.15.1.1 Floors: The floors and spaces where motor vehicles are stored, repaired or operated shall be of noncombustible, liquid-tight construction.

Exception: In floors and areas where no repair works are carried out may be surfaced or waterproofed with asphaltic paving materials.

2.15.1.2 Spill Control: The floors containing hazardous repair or other works shall be recessed a minimum of 100 mm so as to prevent flow of liquids to adjoining areas.

2.15.1.3 Drainage: The buildings and areas shall be provided with approved drainage system to direct the flow of liquids to an approved location or room or area designed to provide secondary containment of the hazardous materials and fire protection water.

The drains shall be designed with adequate slope and section to carry the design discharge of the sprinkler system. The material used in the drains shall be suitable for drainage of the storage materials.

The quality of discharged liquids must attain approved level before discharging into the public sewer or natural stream or river.

2.15.1.4 Smoke and Heat Vents: Smoke and heat vents shall be provided in areas or rooms containing hazardous materials exceeding the exempt amount of Table 3.2.5.

2.15.2 Location on Property

Buildings of Occupancy K shall comply with the requirements for location on property and fire resistive exterior walls and openings as specified in Sec 2.4.1.

2.15.3 Access and Exit Facilities and Emergency Escapes

Facilities for access and exit and emergency escape shall comply with the provisions set forth in Sec 1.6 Chapter 1 Part 3, Chapter 3 Part 4 and Appendix F.

2.15.4 Lighting, Ventilation and Sanitation

All buildings or part of a building classified as Occupancy K shall conform to the provisions of Sec 1.16 Chapter 1 Part 3, Chapters 1 and 3, Part 8.

2.15.5 Shaft and Enclosure

Elevator shafts, vent shafts and other vertical openings shall be enclosed conforming to the provisions of Tables 3.3.1 (a) and (b). Exit requirements shall comply with Chapter 3 Part 4.

2.15.6 Fire Detection, Alarm, Evacuation and Extinguishment System

All buildings shall conform to regulations set forth in Part 4 of this Code.

2.16 Requirements For Occupancy L—Utility Buildings

Buildings shall be classified as Occupancy L in accordance with Sec 2.1.16.

2.16.1 Construction, Height and Allowable Area

The buildings or parts thereof classified as Occupancy L shall be limited to the type of construction set forth in Table 3.2.4 and Sec 2.4.3, and shall comply with the provisions of Sec 1.8 Chapter 1 Part 3, and Sec 2.4.2 to meet the requirements and limitations of height and area.

2.16.2 Location on Property

Buildings of Occupancy L shall comply with the requirements for location on property and fire resistive exterior walls and openings as specified in Sec 2.4.1.

2.16.3 Access and Exit Facilities and Egress System

Facilities for access and exit and egress system shall comply with the provisions set forth in Sec 1.6 Chapter 1 Part 3 and Chapter 3 Part 4.

2.16.4 Lighting, Ventilation and Sanitation

All buildings or part of a building classified as Occupancy L shall conform to the provisions of Sec 1.16 Chapter 1 Part 3, Chapters 1 and 3, Part 8.

2.16.5 Shaft and Enclosure

Elevator shafts, vent shafts and other vertical openings shall be enclosed conforming to the provisions of Tables 3.3.1 (a) and (b). Exit requirements shall comply with Chapter 3 Part 4.

2.16.6 Fire Detector, Alarm, Evacuation and Extinguishment System

All buildings shall conform to regulations set forth in Part 4 of this Code.

2.16.7 Special Hazard

2.16.7.1 Since the nature of use of this occupancy involves hazard, special consideration for maintenance and operational safety must be ensured. Depending upon the degree of hazard involved, this occupancy type may have separate and isolated structure.

2.16.7.2 Chimneys and vents and ventilation ducts shall be of noncombustible materials.

All boilers, central heating plants, electrical rooms or hot water supply boiler shall be separated from the rest of the occupancies or uses by not less than 2 hour fire resistive construction.

The devices that generate a spark, flame or glow capable of igniting gasoline shall not be installed or used within 0.5 m of the floor.

Equipment or machinery that produces or emits combustible or explosive dust or fibers shall be provided with an approved dust collecting and exhaust system.

The equipment or system that is used to collect or process or convey combustible dust or fibers shall be installed with explosion venting or containment system.

2.17 Requirements For Occupancy M—Miscellaneous Buildings

Buildings shall be classified as Occupancy M in accordance with Sec 2.1.17.

2.17.1 General

The buildings or parts thereof classified as Occupancy M shall be limited to the type of construction set forth in Table 3.2.4 and shall comply with the requirements of Sections 1.8 and 2.4.2 to meet the requirements of height and area limitations.

Any building or portion thereof that exceeds the limitations provided in this Chapter shall be classified in the occupancy group other than M that it most nearly resembles.

2.17.2 Location on Property

The location on property for Occupancy M shall conform to Sec 2.4.1.

2.17.3 Access and Exit Facilities and Emergency Escapes

Access and exit facilities for Occupancy M shall comply with the specification set in Sec 1.6 Chapter 3, Part 4.

2.17.4 Lighting, Ventilation and Sanitation

All buildings or part of a building classified as Occupancy M shall conform to the provisions of Sec 1.16 Chapters 1 and 3, Part 8.

2.17.5 Shaft and Exit Enclosures

Elevator shafts, vent shafts and other vertical openings shall be enclosed conforming to the provisions of Tables 3.3.1 (a) and (b). Exit requirements shall comply with the requirements of Chapter 3, Part 4.

2.17.6 Fire Detection, Alarm, Evacuation and Extinguishment System

All buildings shall conform to regulations set forth in Part 4 of this Code.

Table 3.2.6: A—Z List of Occupancy Classification

Use or Occupancy	Brief Description	Occupancy Class/Sub-class
A		
Adhesives manufacture	Excluding manufacture of basic components	G or J depending on nature of materials involved
Advertising displays manufacture		G
Agricultural machinery manufacture	Including repairs	G

Use or Occupancy	Brief Description	Occupancy Class/Sub-class
Agriculture	Without nuisance or sales limitation	H
Agricultural	Small farm house, (limited to storage quantity)	F
	Large farm house, storage quantity unlimited	H or J
	Small grain processing unit, (limited to quantity)	G
	Large grain processing unit, quantity unlimited	G or J
Aircraft manufacture (including parts)		G or J depending on nature of materials and process involved
Airports		MIXED USE (depending on detail requirement)
Amusement parks, children's	(See children's amusement parks)	-
Amusement park activities		I
Animal	Animal hospitals	F
	Animal pound (for stray and lost animal)	H
	Animal crematorium	G
	Killing establishments, for retail sales	F
	Slaughtering, processing and packing	G
Antique stores		F
Apartments	(see residential)	
	in walkup buildings	A
	In high rises	A
	in housing complex	A
Apartment hotels		A5
Apparel	(See clothing)	

Use or Occupancy	Brief Description	Occupancy Class/Sub-class
Appliances	Electrical appliance Manufacturing	G
	Television, radio, phonograph or household appliance stores, (Limited as to floor areas)	F
	Television, radio, phonograph or household appliance stores, (Unlimited)	F
	Household appliance repair shops	F
Arenas, auditoriums, or stadiums	See Assembly (Limited as to capacity)	I
	See Assembly (Unlimited)	I
Art Galleries	Commercial (sales included)	F
	With exhibition open to public viewing for limited period (sales included)	I
Art goods manufacture, religious temple or church, excluding foundry operations		G
Art metal craft shops		F
Art needle work	Six occupants or less	Non-separated use to A1 and A2 Occupancy
	More than six occupants (see industrial)	G
Artist's supply stores		F
Asphalt or asphalt products	Manufacture	J
Assembly	Large assembly with fixed seats	I1
	Small assembly with fixed seats	I2
	Large assembly without fixed seats	I3
	Small assembly without fixed seats	I4
	For sport facilities	I5
Athletic equipment manufacture		G

Use or Occupancy	Brief Description	Occupancy Class/Sub-class
Athletic goods stores		F
Auctions rooms, open to public		I
Auditoriums	See assembly	I
Automatic laundries		G
Automobiles	Dead Storage	H
	Driving Schools	E
	Glass or mirror shops	F
	Washing	K
	Manufacture, including parts, or engine rebuilding	J
	Rental establishments	K
	Repairs, body	K
	Repairs, without body repairs	K
	Sales open or enclosed	K
	Seat cover or convertible top establishments, selling or installation	F
	Showrooms, no repair services	K
	Supply stores, no repair services	F
	Automotive service stations	Tire sales establishments, limited to quantity
Tire sales establishments, unlimited		J
Wrecking establishments		G
Automotive service stations	Limited as to total area	K
	Unlimited...	K
Awnings	Custom shops	H
	Manufacture, with no limitation on production or on floor area	G

Use or Occupancy	Brief Description	Occupancy Class/Sub-class
B		
Bakeries	Home-made, six or less occupants (baking included)	non-separated use to main occupancy
	Large scale, more than six occupants (baking included)	G
	Sales only	F
Banks,	Including drive-in banks	E
Banquet halls		I
Bar, alcoholic		I
Barber shops		F
Barns		H
Barracks	(See residential)	A4
Baths, steam		I
Beaches, commercial		Not applicable
Beauty parlors		F
Beverages	Bottling works	G
	Manufacture, Alcoholic	J
	Non-alcoholic	G
Bicycle	Manufacture	G
	Rental or repair shops	F
	Sales	F
Billiard parlors		I
Blacksmith shops	small scale (limited to six occupants), repair or making	F
	Unlimited	G
Blueprinting establishments	drawing printing	G
Boarding houses	(See residential)	A
Borstals		C
Boatels		A

Use or Occupancy	Brief Description	Occupancy Class/Sub-class
Boats or ships	Bailer works at port or dock	J
	Breaking	J
	Building or repair, for boats less than 200 ft. in length	J
	Building or repair, for boats 200 ft. or more in length	J
	Docks, for small pleasure boats	Not applicable
	Fuel sales, open or enclosed	
	Un- restricted as to location	F
	Restricted as to location	J
	Rentals opened or enclosed	F
	Sales opened or enclosed	F
Showrooms, with no repair services..	F	
	Storage, repair, or painting, including the incidental sales of boats, boat parts, or accessories, with restrictions on boat size and setbacks	G
Bone distillation		G or J depending on process or material used
Botanical garden structures		M
Book	Binding (see printing)	
	Hand binding or tooling	G
	Store	F
Bottling works, for all beverages		G
Bowling alleys	Limited as to number of lanes	I
	Unlimited	I
Breweries		G
Brick manufacture		J
Brush or broom manufacture		G

Use or Occupancy	Brief Description	Occupancy Class/Sub-class
Building materials sales	open or enclosed, limited as to lot area	F
	Yards, for sales, storage, or handling, open or enclosed, unlimited as to lot area except in the case of lumber yards	F
Bungalow	(See residential)	A
Business	Offices	B1
	Research and testing laboratories	B2
	Essential services	B3
Bus stations	With less than 10 berths	K (bus area) and I (passenger area)
	With 10 or more berths	MIXED (as per detail requirement including K and I)
Bus stops	see Bus stations	
Business machines	Manufacture	G
	Small, repair shops	F
	Stores, sales, or rentals..	F
Business schools or colleges		B
Buying house (garments)	storage restricted to sample	E
C		
Café	Six persons or less	Non-separated use to main Occupancy
	More than six persons (see mercantile)	F
Cafeteria	With commercial kitchen	MIXED (G and I)
	Without commercial kitchen	I
Camera and photo equipment	Manufacture	G
Camps, overnight or outdoor day		MIXED (A, I and other depending on the nature of use)

Use or Occupancy	Brief Description	Occupancy Class/Sub-class
Candy stores		F
Canneries, including food products		J
Canteen	With or without cooking facility	I
Canvas or canvas products manufacture		G2
Cargo terminal	containing low fire-risk materials	H
	containing moderate fire-risk materials	H
	containing high fire-risk materials	J
Carnivals, temporary		I5
Carpentry shops		G
Carpet	Cleaning establishments...	J or G depending on the nature of materials involved
	Manufacture	G
	Carpet, rug, linoleum or other floor covering stores Unlimited	F
Carport	Roofed wall less shelter for car	K or H depending on the nature of use
	Automated mechanical parking	K or H depending on the nature of use
Catering establishments	Commercial kitchen	G
	Office	E
	Storage, open or enclosed	H
	Storage for temporary structure's fabrication material	J
Cattle shed, stables		H
Cement manufacture		G2
Cemeteries		H
Ceramic products	Manufacture	G or J based on nature of material used
	Display and sales	F

Use or Occupancy	Brief Description	Occupancy Class/Sub-class
Chamber, doctors' or dentists', (outpatient only)	50 or less occupants	E
	above 50 occupants	D
Charcoal manufacture		G
Chemicals	Compounding or packaging	G or J depending on nature of materials involved
	Manufacture	G or J depending on nature of materials involved
Child care home		C
Child care institution		C
Children's amusement parks	Small	I
	Medium size	I
	Large size	I
	Unlimited as to size	I
Churches, with fixed pews	(See Assembly with fixed seats)	I
Cigar stores		F
Cinema hall	(See Assembly with fixed seats)	I
Cineplex	(See Assembly with fixed seats)	I
Circuses, temporary	(See Assembly)	I
Class room	School, college or university	B
Clay manufacture		G
Clay pits		Not applicable
Cleaning or cleaning and dyeing establishments	(See dry cleaning)....	
Clinics	With inpatient	D
	Only outpatient, limited to quantity (see chambers, doctors' or dentists')	
	Only outpatient, unlimited	D
	With diagnostic facilities (see diagnostic facilities)	
	Government community clinic	E

Use or Occupancy	Brief Description	Occupancy Class/Sub-class
Coaching centre	(See educational facilities)	B
Cold storage		H
Composite textile mill		G or J depending on nature of material and process used
Cottage industries	Small, fifty or less workers (see industrial facilities) Large, more than fifty workers... (see industrial facilities)	G1 G1 or G2 depending on the nature of material and process used
Clock	Manufacture Stores or repair shops	G F
Clothing	Accessory stores Custom manufacture or altering for retail Manufacture Rental establishments Store, Limited as to floor area Store, Unlimited	F F G or J depending on nature of the material involved F F F
Clubs Non-commercial (members only)	Including accommodation Night-club All types except those with outdoor swimming pools	MIXED (A and I) I
Clubs, for public use	Excluding accommodation Including accommodation	I MIXED (I and A or other occupancies depending upon nature of use)
Clubs, Sporting		MIXED (I and A or other occupancies depending upon nature of use)

Use or Occupancy	Brief Description	Occupancy Class/Sub-class
Coal	Products manufacture	J
	Sales, open or enclosed, Limited as to plot area	J
	Unlimited (see coal storage)	J
	Storage, open or enclosed	J
Coin stores		F
Condensed and powdered milk	Manufacture	J
Coke products	Manufacture	J
Colleges or universities	See educational facilities	B
Colony, government or non-government		MIXED (A and other occupancies depending on use)
Commercial building	(see business and/or mercantile)	
Commercial parking garages or plots	(See garages)	K
Community centers	With commercial kitchen	MIXED (G and I)
	Without commercial kitchen	I
Concrete batching		G
Concrete products manufacture		G
Construction machinery	Manufacture, including repairs	G
Container terminal		H or J (According to the hazard classification regulation of the port authority)
Contractors' establishments	Electrical, glazing, heating, painting, paper hanging, plumbing, roofing, or ventilating	F
	Contractors' yards	Not applicable
Convalescent homes	(See nursing homes)	

Use or Occupancy	Brief Description	Occupancy Class/Sub-class
Convents		MIXED (A, B and I)
Cork products	Manufacture	G
Cosmetics or toiletries	Manufacture..	J
Costume rental establishments		F
Cottage, tourist	(See residential)	A5
Cotton ginning or cotton wadding or liner manufacture		J
Court houses		I
Crate manufacture		G or J depending on the material and process involved
Crematoriums	Animals. Human.	J MIXED (J and I)
Cultural center		Mixed (depending on detail requirement)
D		
Dance halls	Public	I
Dance School		A
Dance studios	(see studios)	
Day camps, outdoor		I
Day care Centre	With six or less children More than six children	Non-separated use to Residential Occupancy C
Decorator's establishment	Office Storage, separated	E H or J depending upon the material involved
Defense Buildings, for critical national defense capabilities		Not Applicable
Delicatessen stores	(See food stores)	F

Use or Occupancy	Brief Description	Occupancy Class/Sub-class
Dental	Instruments manufacture Laboratories (See laboratories, medical or dental)	G
Department stores	not exceeding 300 m ² more than 300 m ²	F1 F2
Diagnostic facilities, medical	Outpatients only	D
Diaper supply establishments		H
Disinfectants manufacture		G
Dispensaries	Attached to hospital See drug store	L F
Dormitories	Universities or colleges (above 12 grade)	A
	Schools (12 grade or below)	C
Drafting instruments	Manufacture	G
Dressmaking shops, custom		F
Drinking places, non-alcoholic	(See cafe)	
Drive-in theaters		I
Drug stores		F
Dry cleaning or clothes pressing establishments	Limited as to floor area, solvents and machine capacity	G or J depending on the process and quantity of material used
Dry cleaning or cleaning and dyeing establishments	Without restrictions	G or J depending on the process and quantity of material used
Dry Cleaning, using other than flammable liquids in cleaning or dyeing operations		G

Use or Occupancy	Brief Description	Occupancy Class/Sub-class
Dry goods stores	Limited as to floor area	F
	Unlimited	F
Dumps		Not applicable
Dyeing facilities/ industries		J
E		
Eating or drinking places	With restrictions on entertainment (see Assembly)	I
	Without restrictions on entertainment or dancing but limited to location in hotels (see Assembly)	I
	Without restrictions (See assembly)	I
Eco park structures		MIXED (depending upon the nature of use)
Educational facilities	Up to higher secondary level	B1
	Training and above-higher-secondary education	B2
	Pre-school facilities	B3
Electric	Power or steam generating plants	G
	Substations, Public transit or railroad	G
	Substations, as part of public distribution system	G
	Substations, low to medium voltage step down, at consumers' end	L
Electrical Appliance	Manufacture	G or J depending upon the process or material to be used
	Stores (including television, radio, phonograph or household appliances)	F
	Contractors (See contractors' establishments)	
	Equipment assembly, not including electrical machinery	G
	Supplies, manufacturing	G

Use or Occupancy	Brief Description	Occupancy Class/Sub-class
Electronics manufacturing		J
Electrolysis works		J
Electrotyping or stereotyping	Limited to quantity	F
	Unlimited (see printing)	G
Embassy or High-commission or Consulate		MIXED (depending on detail requirement)
Engine	including rebuilding or reconditioning	J
Engraving or photo-engraving	Limited to quantity	F
	Unlimited (see printing)	G
Excelsior manufacture		J
Exhibition hall	See assembly	I
Exterminators	See pest control	F
F		
Fabric stores		F
Factory		G or J (depending on process and material involved)
Fairs, temporary		MIXED (I and F)
Feathers	Bulk processing, washing, curing, or dyeing	J
	Products manufacture, except washing, curing or dyeing	J
Felt	Bulk processing, washing, curing, or dyeing	G
	Products manufacture, except washing, curing or dyeing	G
Fertilizer manufacture		J
Field hospital, temporary	With provision for ambulance access (to parks and play grounds)	E
Filling stations	(See refueling station)	B

Use or Occupancy	Brief Description	Occupancy Class/Sub-class
Film, photographic	Manufacture	G
Fire Stations		E
Fish products, packing or processing		G
Fishing tackle or equipment rental or sales		F
Flats	(see residential)	A
	In walkup buildings	A
	In high rises	A
	in housing complex	MIXED (A and other occupancies)
Florist shops		F
Food	Products processing, except meat slaughtering or preparation of fish for packing	G
	Stores, including supermarkets, grocery stores, meat markets, or delicatessen stores	F
Foundries	Ferrous or non-ferrous	G or J (depending on process and material involved)
Fraternity houses	(See colleges or universities)	
Freight depot	See storage and hazardous buildings	H and/or J
Frozen food lockers		J
Fuel briquettes manufacture		G
Fuel sales, open or enclosed	Limited up to exempted quantity	F
	Unlimited, See coal storage or petroleum storage	J
Funeral establishments		I
Fungicides manufacture		G

Use or Occupancy	Brief Description	Occupancy Class/Sub-class
Fur	Goods manufacture, not including tanning or dyeing	G
	Tanning, curing, finishing, or dyeing	J
Furniture	Custom shop, floor area of 100 m ² or less	F
	Custom shop, floor area over 100 m ²	G
	Manufacture	J or G depending upon nature of materials involved
	Store, Limited as to floor area	F
	Store, Unlimited	F
Furriers shops, custom		F
Freight depot		H or J depending on the nature of material involved
G		
Garages	Parking garage	K1
	Private garage	K2
	Repair garage and show-rooms	K3
Garbage incineration or reduction		G
Garden shed		M
Garden supply stores		F
Gardens, truck	(See agriculture)	
Garments industries		G
Gas, fuel	Manufacture	J
	Distribution regulatory system (DRS)	G
Gas manufacture for	Medical purpose	J
	Hot-works (welding)	J
Gasoline service stations	(See refueling stations)	
Gelatin manufacture		G

Use or Occupancy	Brief Description	Occupancy Class/Sub-class
Generating plants, electric or steam		G
Gift stores		F
Glass	Cutting shops Manufacture Products manufacture from previously manufactured glass	F G G
Glazing contractor's establishment	(See contractors' establishments)	F
Glue manufacture		G
Godown	See storage buildings	
Golf	Courses Courses, miniature Driving ranges	Not applicable I I
Grain	Milling or processing Storage	J J
Graphite or graphite products	Manufacture	G
Gravel pits		Not applicable
Grocery stores		F
Group homes	Segregation of occupants on the basis of age group and disabilities (See institutional)	C
Gypsum production industry		J
Gymnasiums	Less than 300 occupants 300 or more occupants Commercial without spectator gallery (max 50 occupants)	I I

Use or Occupancy	Brief Description	Occupancy Class/Sub-class
H		
Hair	Bulk processing, washing, curing, or dyeing	G
	Products manufacture (except washing, curing, or dyeing)	G
	Products manufacture, custom	G
Hall, for incidental show (picture, drama, theatre)	(See assembly)	I
Hardware	Manufacture	G
	Stores	F
	Bodies manufacture	G
	Repair shops	F
Hazardous buildings	Explosion-hazard building	J1
	Chemical-hazard building	J2
	Biological-hazard building	J3
	Nuclear-hazard building	J4
Health centers	With inpatient	D
	Without inpatient (not more than 50 occupants)	E
	Government operated health centers	E or D (depending upon the facilities)
Healthcare facilities	Normal medical facilities	D1
	Emergency medical facilities	D2
Health club		I
Heating contractor's establishment	(See contractors' establishments)	
Heat, ventilation and air-conditioning equipment showrooms	Without repair facilities	F
Heliports		G
Hemp products manufacture		G

Use or Occupancy	Brief Description	Occupancy Class/Sub-class
High Commission	See embassy	
Home for care	of the old and infirm (see institution) of mentally disabled (see institution)	
Home office	Not more than 6 occupants	Non-separated use of Occupancy A
Hosiery manufacture		G
Hospital, except animal hospital	As part of disaster preparedness program	D
	Casualty unit	D
	Emergency unit	D
	Non-profit or voluntary, and related facilities	D
	Proprietary and related facilities	D
Hostels	For adults	A
	For children	C
Hotels	Transient	A
	Apartment hotel	A
	Starred hotel	MIXED
Household	Appliance repair shops	F
	Appliance stores (See appliances television, radio, phonograph, or household appliance stores)	F
Housing, complex multi-storied		MIXED (see appendix)
Housing, cluster		MIXED (see appendix)
Housing, low-income		MIXED (see appendix)
Housing, minimum standard		MIXED (see appendix)
Housing, rehabilitation		MIXED (see appendix)

Use or Occupancy	Brief Description	Occupancy Class/Sub-class
I		
Ice cream stores		F
Ice	Manufacture, dry or natural	G or J (depending on the process or material used)
	Sales, open or enclosed Limited as to lot area	F
	Unlimited	F
Incineration or reduction of garbage, offal, or dead animals		G
Indoor facility, for amusement park		I
Industrial buildings	Low-hazard Industries	G1
	Moderate-hazard Industries	G2
Infirmaries		C
Ink or inked ribbon manufacture		G or J depending on nature of materials involved
Inns	See residential	A
Insecticides manufacture		G or J depending on nature of materials involved
Institution	For care of children	C1
	Custodial, for physically capable adults	C2
	Custodial, for physically incapable adults	C3
	Penal or mental, for children	C4
	Penal or mental, for adults	C5
Institutions, philanthropic or non-profit	With sleeping accommodations	A
	Without sleeping accommodations	

Use or Occupancy	Brief Description	Occupancy Class/Sub-class
Interior decorating establishments	Limited as to floor area for processing, servicing, or repairs	F
	Unlimited, see furniture, textiles or upholstery	F
Irradiation plant		J
J		
Jail	see prisons	
Jewelry	Manufacture	G
	Costume	G
	From precious metals	G
	Shops	F
Junk Yards		Not applicable
Jute products manufacture		G or J (depending on quantity or process)
Juvenile correctional center	For children (see assembly)	
K		
Kennels		H
Kindergarten	See educational facilities	B
Knitwear industries		G2
L		
Laboratories	Medical or dental, for research or testing, with limitations on objectionable effects	E
	Research, experimental, or testing, unlimited	(G or J) and H depending on process or material used in compliance with safety standards
	Radiological laboratory, see radiological facilities	
	Pathological laboratory	G (in compliance with safety standards)

Use or Occupancy	Brief Description	Occupancy Class/Sub-class
	Microbiological laboratory, for diagnostic facility	G or J depending on process or material used in compliance with safety standards
	Microbiological laboratory, for research	G or J depending on process or material used in compliance with safety standards
	Microbiological laboratory, for academic facility	G or J depending on process or material used in compliance with safety standards
Lampblack manufacture		G
Laundries, with no limitations on type of operation		G
Laundry establishments, hand or automatic self-service		G
Lavatory, public	see public toilet	
Leather	Tanning, curing, finishing or dyeing	J
	Goods stores	F
	Products manufacture	G
Libraries	Reading area (see assembly)	I
	Stack area (see storage)	H
	Reading and stack area combined	MIXED (I and H)
Lillah boarding	For children (see institutional)	C
	For adults (see residential)	A
Linen supply establishments		
Linoleum	Manufacture	J
	Stores (See carpet stores)	

Use or Occupancy	Brief Description	Occupancy Class/Sub-class
Liquor stores, package		F
Livestock	Storage, more than six castles	H
	Slaughtering or preparation for packing	G
Loan offices		E
Locksmith shops		F
Lodging	See residential	A
Luggage	Manufacture	G
	Stores	F
Lumber	Processing or woodwork, bulk	G
	Sales, Limited as to lot area	G
	Sales, Unlimited	G
	Yard, Limited as to lot area	G
	Yard, Unlimited	G
M		
Machine	Shops including tool, die or pattern making	G
	Tools manufacture	G
Machinery	Manufacture or repair, Heavy	G or J depending on material and process
	Miscellaneous or electrical equipment	G or J depending on material and process
	Rental or sales establishments	F
	Repair shops	F
Machines, business	(See business machines)	
Madrassa	(See institution)	
Manure storage		H
Markets	Retail, including meat (See mercantile)	F
	Wholesale, produce or meat (See mercantile)	F
Masseurs		F

Use or Occupancy	Brief Description	Occupancy Class/Sub-class
Matches manufacture		J
Mattress manufacture, rebuilding or renovating		J
Meat	Markets, Retail (See food stores)	F
	Markets, Wholesale	F
	Slaughtering or preparation for packing	G
Medical	Appliances, Custom manufacture	G
	Appliances, Manufacture	G
	Stores	F
	Instruments, manufacture	G
	Laboratories (See laboratories, medical)	
	Offices or group medical centers, Limited as to location within building	E
	Offices or group medical centers, Unlimited	E
Meeting halls	See Assembly	I
Mess houses	(See residential)	
Metal Fabrication industry		J
Metal Assembly industry		J
Metals manufacture	Alloys or foil, miscellaneous	G
	Casting or foundry products, heavy	G
	Finishing, plating, grinding, sharpening, polishing, cleaning, rust proofing, heat treatment, or similar processes	G
	Ores reduction or refining	G
	Products treatment or processing	G
	Reduction, refining, smelting, or alloying	G
	Stamping or extrusion	G
	Treatment or processing	G

Use or Occupancy	Brief Description	Occupancy Class/Sub-class
Mental institution	Without detention facilities	D
Mental hospitals	(See institution)	C
Mercantile	Small shops and markets	F1
	Large shops and markets	F2
	Refueling station	F3
Mill	(See industrial and/ or hazardous buildings)	G or J (depending on material or process)
Mill works, and woodworking, wood distillation and particle boards manufacturing		J
Millinery shops		F
Mining machinery manufacture	Including repairs	G
Mirror silvering shops		G
Miscellaneous buildings	Special structures	M1
	Fences, tanks and towers	M2
Monasteries		MIXED
Monument	Sales establishments, with incidental processing to order	F
	Works, with no limitations on processing	G
Mosque	(See assembly)	I
Motels	(See residential)	A
Motion picture production and filming facilities		MIXED (G and other Occupancies as required)
Motorcycles	Manufacture	G
	Repairs, body	G
	Repairs, except body repairs	G
	Sales open or enclosed	F
	Showrooms, with no repair services (See garage)	K
Motor freight stations	See truck terminals	

Use or Occupancy	Brief Description	Occupancy Class/Sub-class
Motor vehicles	Dead storage	H
	Moving or storage offices, Limited as to storage	K
	Unlimited	K
Movie theatre	See assembly	I
Museums	See assembly	I
Music stores		F
Music studios	See studios	
Musical instruments	Manufacture, Excluding pianos and organs	G1
	Including pianos and organs...	G2
	Repair shops...	G1
N		
Newspaper publishing		MIXED (G and E)
	Printing	G
	Office	E
Newsstands, open or closed		F
Novelty products manufacture		G
Novitiates...	See institution	A
Nuclear medicine facilities	see radiological facilities	
Nuclear plant		J
Nurseries	See agriculture	
Nursing homes	Philanthropic or non-profit	C or D depending on the type of occupants and nature of use
	Private	C or D depending on the type of occupants and nature of use
Nursery schools	See pre-school	B

Use or Occupancy	Brief Description	Occupancy Class/Sub-class
O		
Oakum products manufacture		G
Office equipment or machinery repair shops		F
Office or business machine stores	sales or rental	F
Offices	General	E
	Business, professional or Governmental (see business occupancy)	E
	Dental, medical, or osteopathic (See medical offices)	E
	Wholesale, with storage restricted to samples (see business occupancy)	E
Offices, small	Architect's/engineer's/ consultant's (Limited to six occupants)	Non-separated use of Occupancy A
	Architect's/engineer's/consultant's (more than six occupants)	E
Oil cloth manufacture		J
Oil sales, open and enclosed	Limited as to lot area	F
	Unlimited (See petroleum or petroleum products storage)	J
Old home	See institution	C
Optical	Equipment manufacture	G
	Goods manufacture	G
Orphanage	See institution	C
Optician or optometrist establishments		F
Orthopedic	Appliances, Custom manufacture	G
	Manufacture	G
	Stores	F
	Instruments, manufacture	G
Osteopathic offices	(See medical offices)	

Use or Occupancy	Brief Description	Occupancy Class/Sub-class
P		
Packing or crating establishments		G2
Packing materials manufacture		G2
Pagoda	See Prayer hall	
Paint	Manufacture	J
	Stores, limited to quantity	F
	Stores, unlimited	H
Painting contractors	(See contractors' establishments)	
Paper	Mills (See wood pulp or fiber)	G
	Products manufacture	G
	Stock companies	H
Paper-hanging contractors	(See contractors' establishments)	
Parish houses		A
Parks, public or private	With provision for emergency vehicle access as part of disaster preparedness program	Not applicable
Park structures		M
Parking garages, public	See garage, parking	K
Parking lots, public	See garage, parking	K
Passenger stations and terminals	Small, passenger station	MIXED (depending on nature of use)
	Large, passenger station or terminal	MIXED (depending on nature of use)
	Passenger and freight terminal	MIXED (depending on nature of use)
Peat storage		H
Perfumed or perfumed soaps	compounding only, not including soap manufacture	J

Use or Occupancy	Brief Description	Occupancy Class/Sub-class
Pest control	Exempted quantity only	F
Pet shops		F
Petrol pump	See refueling station	F
Petroleum or petroleum products	Refining	J
	Storage and handling	J
Pharmaceutical products manufacture		G or J depending on nature of materials used
Philanthropic, religious or non-profit activities		MIXED (depending on nature of use)
Phonograph	Repair shops	F
	Stores (See appliances)	F
Photocopying and book binding	Binding limited in quantity	F
Photographic	Developing or printing establishment, Retail	F
	Developing or printing establishment, Wholesale, Limited as to floor area	H
	Developing or printing establishment, Wholesale, Unlimited	H
	Equipment, Manufacture (film)	J
	Equipment, Manufacture (except film)	G
	Stores	F
	Studios	F
Supply stores (limited to exempted quantity)	F	
Photostatting establishments		F
Physical culture establishments		I
Picture framing stores		F
Plants, Industrial		G
Plants, Refrigeration		G

Use or Occupancy	Brief Description	Occupancy Class/Sub-class
Plastics	Products, manufacture	J
	Raw, manufacture	J
Plate making	(See printing)	
Playgrounds	With provision for emergency vehicle access as part of disaster preparedness program	I
Plots, parking	(See parking lots, public)	
Plumbing	Contractors' establishments	F
	Equipment manufacturer (See tools or hardware manufacturing)	
	Showrooms, without repair facilities	F
Police Stations		E
Pool halls		I
Porcelain products manufacture		G
Post offices		E
Poultry	Storage (live)	H
	Killing establishments, for retail sales on the same zoning lot only	G
	Packing or slaughtering	G
Power plant		G
Power stations	As part of national grid power distribution system	E
	At consumer's end	L
Prayer hall	See assembly	I
Precision instruments manufacture	Optical equipment, clocks, or similar products	G
	Medical, dental, or drafting instruments, optical goods, or similar products	G
Pre-school facilities	See educational	

Use or Occupancy	Brief Description	Occupancy Class/Sub-class
Press club, for journalist		I
Press, printing	See printing	
Primary schools	See educational	
Printing	Custom	G
	Limited as to floor area	G
	Unlimited	G
Printing, publishing, dyeing and printing industries		J
Prisons	See jail	C
Produce or meat markets, wholesale		F
Psychiatric sanatoria	With detention facilities (see institution)	
Public auction rooms		MIXED (F and/or I)
Public transit yards		Not applicable
Publishing	With printing	G
	Without printing	E
Pumping stations	Water or sewage (for city supply system)	G
	Dedicated to consumer	U
Q		
Quarter, Staff	Government or non-government	A or Mixed (See appendix)
R		
Racetracks		I
Radio	Appliance repair shops	F
	Stores	F
	Studios, with less than six occupants	Non-separated use to main Occupancy
	Studios, without transmission tower	E
	Studios, with transmission tower (see radio station)	
	Towers, non-accessory	M

Use or Occupancy	Brief Description	Occupancy Class/Sub-class
Radio station		Mixed (depending on the type of use)
Radiological facilities, medical	In compliance with the standard of atomic energy commission	D
Radioactive waste disposal services		J
Railroad	Equipment manufacture, including railroad cars or locomotives Passenger stations Right-of-way Substations Small or medium size Large Railroads, including rights-of-way, freight terminals, yards or appurtenances, or facilities or services used or required in railroad operations, but not including passenger stations	G or J depending on the material and hot-work used I Not applicable G G Not applicable
Rail station		Mixed (depending on the type of use)
Record stores		F
Recreation centers, non-commercial		I
Recreation piers	See assembly	I
Recreational vehicles manufacturing		J
Rectories		A
Reducing salons		I
Reformatories	See institutional facilities	
Refreshments stand, drive-in		I
Refrigerating plants		G

Use or Occupancy	Brief Description	Occupancy Class/Sub-class
Refueling station	Petroleum product storage within exempted quantity	E
Refuse incinerators		J
Religious or church art goods manufacture		G
Research establishment	dealing with non-hazard or low hazard materials only	E
Residences	Single-family detached	A
	One-family semi-detached or two-family detached or semi-detached	A
	Boarding or rooming houses	A
	Rest homes (See nursing homes)	
Residential	Single family dwelling	A1
	Two family dwelling	A2
	Flats or apartments	A3
	Mess, boarding house, dormitories and hostels	A4
	Hotels and lodging houses	A5
Rest Houses		
Restaurant	Dining area	I
	Performing area, limited	I
	Kitchen and storage	L
Reviewing stand		I
Riding academies, open or enclosed		E and H
Roofing contractors' establishments		F
Rooming houses	See residential	A
Rubber	Processing or manufacture, natural or synthetic	J
	Products manufacture (excluding all natural or synthetic rubber processing)	J
Rug stores	(See carpet stores)	

Use or Occupancy	Brief Description	Occupancy Class/Sub-class
S		
Sail-making establishments		F
Salvage storage		H
Sand pits		Not applicable
Saloon, hair dressing		F
Sanatoriums	With detention facilities (see institution)	C
	Without detention facilities	D
Sawmills		G
Scenery construction		G
School (see educational)	Dormitories, for children	C
	Nursery, kindergarten, elementary or secondary schools	B
	Trade or other schools for adults, limited as to objectionable effects	B
	Trade schools for adults, unlimited	B
	For physically challenged, without accommodation	B
	For mentally challenged, without accommodation	B
Scrap metal, paper and rag storage		H
Secondary school	See educational	B
Seed stores		F
Seminar halls	For 50 or more occupants, See assembly	I
Seminaries		B
Settlement houses	(see housing)	MIXED (A and other Occupancy depending on the nature of use)
Sewage	Disposal plants	G
	Pumping stations	G

Use or Occupancy	Brief Description	Occupancy Class/Sub-class
Sewing machine stores, selling household machines only		F
Ship chandlers, candle shops		F
Ship or boat building or repair yards	For ships 200 ft. in length or over	G
Shipping, waterfront		Not applicable
Shoes	Manufacture Repair shops Stores	G or J depending on the process and material involved F F
Shops	see definition	F or G (depending on the process and material involved)
Shop-house		mixed occupancy (A and F) or (A, F and G)
Sign painting shops	Limited as to floor area Unlimited	G G
Silk processing and spinning		J
Silo, for storage of grain		H
Silver plating shops, custom		G
Silverware manufacture, plate or sterling		G
Sisal products manufacture		J
Skating rinks, roller	Indoor Outdoor	I I
Slag piles		Not applicable

Use or Occupancy	Brief Description	Occupancy Class/Sub-class
Slaughtering of animals or poultry		G
Soap or detergents	Manufacture, including fat rendering Packaging only	J G
Soldering shops		G
Solvent extracting		J
Sorority houses	(See hostel)	A
Sports centre		I
Sporting equipment manufacture.		G
Sporting goods stores		F
Stable for horses		H
Stadiums	Indoor or outdoor, with access for emergency vehicle as part of disaster preparedness program	I
Staff quarter	see quarter, staff	
Stamp stores		F
Station	Rail, bus, air and water way	MIXED (I and other Occupancy depending on the nature of use)
Stationary stores		F
Statuary, mannequins, figurines, religious or church art goods manufacture, excluding foundry operations		G
Steel products	Miscellaneous fabrication or assembly (without hot-work) Structural products manufacture	G J
Stock yards or slaughtering of animals or poultry		G

Use or Occupancy	Brief Description	Occupancy Class/Sub-class
Stone processing or stone products		G
Storage buildings	Low-fire-risk storage	H1
	Moderate-fire-risk storage	H2
Storage facilities	Wholesale (see storage buildings)	H
	Offices, limited to quantity	Non-separated use
	For cotton/jute/ paper/textile	J
Stores	See definition	F
Students' halls of residence	For children	C
	For adults	A
Studios	Music, dancing, or theatrical	I
	Radio (see radio studio)	
	Television, with spectator	MIXED (I, E or G)
	Television, without spectator	MIXED (depending on nature of material and process involved)
Sugar	Production and Refining	J
Super market	See mercantile	F
Swimming pools	Commercial	I
	Non-Commercial (See clubs)	I
T		
Table tennis halls	See assembly	I
Tailor shops, custom		F
Tanning (See leather or fur)		J
Tapestries manufacture		G
Tar products manufacture		G
Taxidermist shops		F
Telegraph offices		E

Use or Occupancy	Brief Description	Occupancy Class/Sub-class
Telephone exchanges or other communications equipment structures		E
Television	Repair shops Stores (See appliances) Studios (see television studios) Towers, non-accessory	F F M
Television station	See business	MIXED (E3 with other Occupancies according to detail requirement)
Temple	See prayer hall	
Tennis courts, indoor		I
Terminal facilities at river crossings for access to electric, gas, or steam lines		G
Test laboratory	involving low hazard material	E
Textiles	Bleaching (see industrial) Products manufacture (see industrial) Spinning, weaving, manufacturing, dyeing, printing, knit goods, yarn, thread, or cordage (see industrial)	G G G
Textile industries and jute mills	including canvas, cotton cloth, bagging burlap, carpet and rags (see industrial)	J
Theater	See assembly	I
Theaters, drive-in	(See studios)	
Theatrical studios	without spectator	G
Tile	Manufacture	G
Tire sales establishments	Including installation services, Limited to quantity Including installation services, unlimited quantity	F J

Use or Occupancy	Brief Description	Occupancy Class/Sub-class
Tobacco	Curing or manufacture, or tobacco products manufacture	J
	Stores (retail)	F
Toilet, public		L
Toiletries manufacture		G or J depending on the material and process involved
Tool or hardware manufacture	See industries	G
Topsoil storage	See storage	H
Tourist cabins	See residential	A
Towel supply establishments		F
Toys	Manufacture	G
	Stores	F
Trade or other schools for adults	Limited as to objectionable effects (see educational)	B
	Unlimited (see educational)	B
Trade expositions	Limited as to rated capacity	I
	Unlimited	I
Trailer, truck, bus	Manufacture, including parts	G or J depending on the material and process involved
	Repairs, body	G or J depending on the material and process involved
	Sales open or enclosed	F
	Showrooms, with no repair services	F
Training center	lecture based, limited to quantity (see educational facilities)	E1 or B2
	vocational or demonstrative (see educational facilities)	B2
Transit substations	Small or medium size	G
	Large	G

Use or Occupancy	Brief Description	Occupancy Class/Sub-class
Transport terminal	Small or medium size	MIXED depending on nature of use
	Large	MIXED depending on nature of use
Travel agency	(see business)	E
Travel bureaus	(see business)	E
Truck	Manufacture (including parts) or engine rebuilding	G or J depending on the material and process involved
	Repairs, body	G
	Repairs, except body repairs	G
	Sales open or enclosed	F
	Showrooms, with no repair services	F
	Trucking terminals or motor freight stations, Limited as to lot area	K1
	Trucking terminals or motor freight stations, Unlimited	K1
Tutorial homes	More than six occupants (see educational)	B
Turpentine manufacture		J
Typewriter stores		F
Typewriter or other small business machine repair shops		F
Typography	(See printing)	
U		
Umbrellas	Manufacture	G
	Repair shops	F
University	See educational facilities	B2
Upholstery	Manufacturing	J
	Bulk, including shops not dealing directly with consumers	J
	Shops dealing directly with consumers, retail	F
Utility		L

Use or Occupancy	Brief Description	Occupancy Class/Sub-class
V		
Variety stores	Limited as to floor area	F
	Unlimited	F
Varnish manufacture		J
Vehicles	Dead storage of motor	H
	Manufacture, children's	G
	Storage, commercial or public utility, open or enclosed	K
Venetian blind, window shade, or awning	Custom shops, limited as to floor area	F
	Manufacture, with no limitation on production or on floor area	J or G depending upon nature of materials involved
Ventilating contractors	(See contractors' establishments)	F
Ventilating equipment showrooms	Without repair facilities	F
Video games shop		F
Vihara, Buddhist	with occasional or regular assembly	mixed use
W		
Wallpaper stores	Limited to quantity	H
Warehouses		H or J (depending on the nature of material stored)
Watch or clock stores or repair shops		F
Watch making		G
Waterfront shipping		Not applicable
Water pumping stations	At distributor's end	G
	At consumer's end	L
Water tank tower		M
Wax products manufacture		G

Use or Occupancy	Brief Description	Occupancy Class/Sub-class
Weaving, hand	Up to six hand-weaving machines	Non- separated use to main Occupancy
	More than six hand-weaving machines	G
Wedding chapels	See assembly	I
Welding shops	Arc welding only	G
	Gas welding within exempted quantity	G or J depending upon the quantity of material and process
Welfare centers		
Wholesale establishments		H or J depending upon the nature of material
Wholesale offices or showrooms, with storage restricted to samples		E
Window manufacture		G
Window shades	Custom shops, limited as to floor area	F
	Manufacture, without limitation on production or on floor area	G
Wood	Bulk processing or woodworking	G
	Distillation	G
	Products manufacture	G
	Pulp or fibre, reduction or processing, including paper mill operations	G
	Sales, open or enclosed, Limited as to lot area	F
	Unlimited (See lumber yards)	F
	Woodworking shops, custom	J or G depending upon nature of materials involved
Wool scouring or pulling		G
Workshops	With hot-works	J
	Without hot-works	G

Use or Occupancy	Brief Description	Occupancy Class/Sub-class
X		
X-ray facilities	See radiological facilities	
Y		
Yard		Not applicable
Yard, ship	See ship or boat building or repair yards	
Yarn, manufacturing		G or J depending on the quantity (see Table 3.2.5)
Z		
Zoo structures		M

** The occupancy classification for any project, not included in this list, shall be determined through the following process:

- i. The functional requirements of the unidentified occupancy shall be compared with the Occupancy use type, classification, sub-classification categories and descriptions to match with the given occupancies to find the most similar Occupancy,
- ii. If process (i) fails to determine the Occupancy, the project will be referred to the Board of Appeal constituted as per directives of Part 2 Chapter 2. The Board of Appeal shall determine the Occupancy, and
- iii. The decision of Board of Appeal shall be considered as an explanatory material of this Code and shall be added as addendum to this Code. For any future projects of similar nature this addendum will suffice and need not be referred to the Board of Appeal again.

PART III
Chapter 3

Classification of Building Construction Types Based on Fire Resistance

3.1 General

3.1.1 Classification by Type of Construction

For the purpose of this Code, every room or space of a building or a building itself hereafter altered or erected shall be classified in one specific type of construction as grouped as follows:

GROUP I: Noncombustible, subdivision

Type I-A: 4 hour fire protected

Type I-B: 3 hour fire protected

Type I-C: 2 hour fire protected

Type I-D: 1 hour fire protected

Type I-E: Unprotected

GROUP II: Combustible subdivision

Type II-A: Heavy timber

Type II-B: Protected wood joist

Type II-C: Unprotected wood joist

Type II-D: Protected wood frame

Type II-E: Unprotected wood frame

The fire resistance ratings of various types of construction for structural and non-structural members are specified in Tables 3.3.1 (a) and (b). For hazardous Occupancies involving an exceptionally high degree of fire risk or an exceptionally high concentration of combustible or flammable content, the Authority may increase the requirement of Table 3.3.1 (a).

Buildings having a height of more than 33 m shall be constructed with non-combustible materials.

The fire resistance ratings of various building components shall conform to ASTM standards.

No building or portion thereof shall be designated a given construction type unless it fully conforms to the minimum requirements for that Construction type.

When a type of construction is utilized which is superior than the type of construction required by this Code, there shall be no requirement to upgrade the rest of the construction to comply to that higher type of construction and the designated construction type shall be that of the lesser classification, unless all of the requirements for the higher classification are met.

3.1.2 Group I: Non-Combustible Construction

Buildings or portion thereof in Non-combustible Construction Group I are those in which the walls, exit-ways, shafts, structural members, floors, and roofs are constructed of non-combustible materials and assemblies having fire-resistance ratings specified in Table 3.3.1 (a). The Non-combustible group consists of Construction Type I-A, I-B, I-C, I-D and I-E.

3.1.2.1 Construction Type I-A

This construction type includes buildings in which the bearing walls and other major structural elements are generally of four-hour-fire-resistance rating.

3.1.2.2 Construction Type I-B

This construction type includes buildings in which the bearing walls and other major structural elements are generally of three-hour-fire-resistance rating.

3.1.2.3 Construction Type I-C

This construction type includes buildings in which the bearing walls and other major structural elements are generally of two-hour-fire-resistance rating.

3.1.2.4 Construction Type I-D

This construction type includes buildings in which the bearing walls and other major structural elements are generally of one-hour-fire-resistance rating.

3.1.2.5 Construction Type I-E

This construction type includes buildings in which the bearing walls and other major structural elements generally have no fire-resistance rating.

3.1.3 Group II: Combustible Construction

Buildings or portion thereof in Combustible Construction Group II are those in which the walls, exit-ways, shafts, structural members, floors, and roofs are constructed wholly or partly of combustible materials having fire-resistance ratings specified in Table 3.3.1 (b). The Non-combustible group consists of Construction Type II-A, II-B, II-C, II-D and II-E.

3.1.3.1 Construction Type II-A

This Construction type includes heavy timber construction in which fire-resistance is attained by—

- (a) Limiting the minimum sizes of wood structural members and the minimum thickness and composition of wood floors and roofs;
- (b) Avoiding concealed spaces under floors and roofs or by providing fire-stopping protection for these spaces; and
- (c) Using fastening, construction details, and adhesives for structural members as required by this Chapter and Part 4.
- (d) The minimum dimensions for framing members shall be prescribed in this Chapter and Part 4, except that members are protected to provide a fire-resistance rating of at least one hour need not comply with this requirement.

3.1.3.2 Construction Type II-B

This Construction type includes buildings and portion thereof in which

- (a) Exterior walls, fire walls, exit-ways, and shaft enclosures are of non-combustible materials having the required fire-resistance ratings; and
- (b) The floors, roofs and interior framing are wholly or partly of wood of smaller dimensions than required for type II-A construction, or are of other combustible or non-combustible materials, having the required fire-resistance rating.

Table 3.3.1 (a): Fire Rating for Construction Group I: Non-Combustible

Exterior wall with Fire Separation Distance of	Construction Element Exterior Wall	TYPE -I-A		TYPE -I-B		TYPE -I-C		TYPE -I-D		TYPE -I-E	
		Ratings in Hours	Exterior Opening ^{a,b}	Ratings in Hours	Exterior Opening ^{a,b}	Ratings in Hours	Exterior Opening ^{a,b}	Ratings in Hours	Exterior Opening ^{a,b}	Ratings in Hours	Exterior Opening ^{a,b}
0.9m or less	Bearing	4	N.P	3	N.P	2	N.P	2	N.P	2	N.P
	Non-bearing ^f	2		2		2		2		2	
More than 0.9m but less than 4.5m	Bearing	4	as per provisions of this Code	3	as per provisions of this Code	2	as per provisions of this Code	2	as per provisions of this Code	2	as per provisions of this Code
	Non-bearing ^f	2		2		2		2			
4.5m or more but less than 9.0m	Bearing	4	as per provisions of this Code	3	as per provisions of this Code	2	as per provisions of this Code	1	as per provisions of this Code	0	as per provisions of this Code
	Non-bearing ^f	1½		1½		1		1		0	

Exterior wall with Fire Separation Distance of	Construction Element Exterior Wall	TYPE -I-A		TYPE -I-B		TYPE -I-C		TYPE -I-D		TYPE -I-E	
		Ratings in Hours	Exterior Opening ^{a,b}	Ratings in Hours	Exterior Opening ^{a,b}	Ratings in Hours	Exterior Opening ^{a,b}	Ratings in Hours	Exterior Opening ^{a,b}	Ratings in Hours	Exterior Opening ^{a,b}
9.0m or more	Bearing	4	N.L	3	N.L	2	N.L	1	N.L	0	N.L
	Non-bearing ^f	0		0		0		0			
Interior bearing walls and bearing partitions		4		3		2		1		0 ^{g,i}	
Enclosure of vertical exits ^e , exit passageways, hoistways and shafts		2		2		2		2		2	
Fire divisions and fire barrier Walls or partitions or ceiling slab		See Table 3.2.1 and provisions of this Code									
Columns ^k , girders, trusses (other than roof trusses) and framing	Supporting one floor	3		2		1½		1		0 ^{g,i}	
	Supporting more than one floor ^l	4		3		2		1		0 ^{g,i}	
Structural members supporting walls		Structural members shall have the same fire resistance rating of wall to be supported, but not less than rating required by the construction classification.									
Floor construction including beams		3		2		1½		1		0 ^{g,i}	
Roof construction, including beams, trusses and framing supported roofs and roof decks ^h	4.5m or less in height above floor to lowest member of ceiling	3		1½		1 ⁱ		1 ⁱ		0 ^{g,i}	
	4.5m to 6m in height above floor to lowest member of ceiling	2 ^{c,i} or 1 ^{d,i}		1½ ^{c,i} or 1 ^{d,i}		1 ⁱ		1 ⁱ		0 ^{g,i}	
	6m or more in height above floor to lowest member of ceiling	2 ^{c,i} or 0 ^{d,g,i}		1½ ^{c,i} or 1 ^{d,g,i}		1 ^{c,i} or 0 ^{d,g,i}		1 ^{c,i} or 0 ^{d,g,i}		0 ^{g,i}	

Exterior wall with Fire Separation Distance of	Construction Element Exterior Wall	TYPE -I-A		TYPE -I-B		TYPE -I-C		TYPE -I-D		TYPE -I-E	
		Ratings in Hours	Exterior Opening ^{a,b}	Ratings in Hours	Exterior Opening ^{a,b}	Ratings in Hours	Exterior Opening ^{a,b}	Ratings in Hours	Exterior Opening ^{a,b}	Ratings in Hours	Exterior Opening ^{a,b}
Shafts (other than exits) and elevator hoistways		2		2		2		2		2	
Fire separation wall and party wall		4		2		2		2		2	
Access corridor leading to fire exits		1		1		1		1		1	
<div style="display: flex; align-items: center; gap: 10px;"> <div style="border: 1px solid black; width: 20px; height: 10px; background-color: #cccccc;"></div> Non-combustible Material; <div style="border: 1px solid black; padding: 2px;">N. P</div> Not Permitted; <div style="border: 1px solid black; padding: 2px;">N. L</div> No Limit </div>											

Table 3.3.1 (b): Fire Rating for Construction Group II: Combustible

Exterior wall with Fire Separation Distance of	Construction Element Exterior Wall	TYPE -II-A		TYPE -II-B		TYPE -II-C		TYPE -II-D		TYPE -II-E	
		Ratings in Hours	Exterior Opening ^{a,b}	Ratings in Hours	Exterior Opening ^{a,b}	Ratings in Hours	Exterior Opening ^{a,b}	Ratings in Hours	Exterior Opening ^{a,b}	Ratings in Hours	Exterior Opening ^{a,b}
0.9m or less	Bearing	2	N.P	2	N.P	2	N.P	2	N.P	2	N.P
	Non-bearing ^f	2		2		2		2		2	
More than 0.9m but less than 4.5m	Bearing	2	as per provisions of this Code	2	as per provisions of this Code	2	as per provisions of this Code	1	as per provisions of this Code	1	as per provisions of this Code
	Non-bearing ^f	2		2		2		1		1	
4.5m or more but less than 9.0m	Bearing	2	as per provisions of this Code	2	as per provisions of this Code	2	as per provisions of this Code	1	as per provisions of this Code	0	as per provisions of this Code
	Non-bearing ^f	2		2		2		1		0	
9.0m or more	Bearing	1	N.L	1½	N.L	1½	N.L	1	N.L	0	N.L
	Non-bearing ^f	0		0		0		0		0	
Interior bearing walls and bearing partitions		2		1		0		1		0	
Enclosure of vertical exits ^e , exit passageways, hoistways and shafts		2		2		1 ⁱ		1 ⁱ		1	
Fire divisions and fire barrier Walls or partitions or ceiling slab		See Table 3.2.1 and provisions of this Code									
Columns ^k , girders, trusses (other than roof trusses) and framing	Supporting one floor	as per provisions of this Code		1		0 or 1 ^j		1		0	
	Supporting more than one floor	as per provisions of this Code		1		0 or 1 ^j		1		0	

Exterior wall with Fire Separation Distance of	Construction Element Exterior Wall	TYPE -II-A		TYPE -II-B		TYPE -II-C		TYPE -II-D		TYPE -II-E	
		Ratings in Hours	Exterior Opening ^{a,b}	Ratings in Hours	Exterior Opening ^{a,b}	Ratings in Hours	Exterior Opening ^{a,b}	Ratings in Hours	Exterior Opening ^{a,b}	Ratings in Hours	Exterior Opening ^{a,b}
Structural members supporting walls		3		2½		2		1½		1	
Floor construction including beams		as per provisions of this Code		1		0 or 1 ⁱ		1		0	
Roof construction, including beams, trusses and framing including arches, domes, shells, cable supported roofs and roof decks ^h	4.5m or less in height above floor to lowest member of ceiling	as per provisions of this Code		¾		0		¾		0	
	4.5m to 6m in height above floor to lowest member of ceiling	as per provisions of this Code		¾		0		¾		0	
	6m or more in height above floor to lowest member of ceiling	as per provisions of this Code		¾		0		¾		0	
Shafts (other than exits) and elevator hoistways		2		2		2		2		2	
Fire separation wall and party wall		4		2		2		2		2	
Access corridor leading to fire exits		1		1		1		1		1	
<div style="display: flex; justify-content: space-between; align-items: center;"> Non-combustible Material ; N. P Not Permitted ; N. L No Limit </div>											

Notes:

- ^a Requirements of protected exterior openings shall not apply to religious assembly. [Protected openings within an exterior separation of 0.9m or less are permitted for buildings classified in Occupancy Groups A provided, however said openings do not exceed in total area of 25% of the façade of the storey in which they are located. The openings however, may not be credited towards meeting any of the mandatory natural light and ventilation as per provisions of this Code. Protection of openings with an exterior separation of 0.9 m to 9 m shall not be required for A-1, A-2 and A-3 Occupancy groups] or to buildings classified in Occupancy groups J, G and H additional requirements for exterior walls and exterior wall openings as per provisions of this Code.
- ^b Upon special application, the area development authorities may permit exterior wall openings to be constructed in excess of the permitted area established by this Table if such openings at the time of their construction are located at least 18m in a direct line from any neighboring building except as otherwise permitted in footnote f. Such additional openings may not however be credited toward meeting any of the mandatory natural light and ventilation requirements of Sec 1.19 Part 3 of this Code. If any neighboring building is later altered or constructed to come within the above distance limitation, the affected exterior openings shall immediately be closed with construction meeting the fire-resistance rating requirements for exterior wall construction of the building in which they are located.
- ^c Applies to occupancy groups J, G and H
- ^d Applies to occupancy groups J, G and H
- ^e See Provisions of this Code for additional impact resistance requirements applicable to certain stair enclosures and for certain exceptions to stair enclosure requirements.
- ^f When two or more buildings are constructed on the Plot and the combined floor area of the buildings does not exceed the limits established by this Code for any of the buildings, not fire-resistance rating shall be required for non-bearing portions of the exterior walls of those buildings facing each other, and there shall be no limitation on the permitted amount of exterior openings.
- ^g Fire retardant treated wood complying with the requirements of this Code may be used.
- ^h Tabulated ratings apply to buildings over one storey in height. In one storey building, roof construction may be of material having zero hour fire-resistance rating.

- ⁱ Materials which are not non-combustible as defined in this Code may be used in nonbearing construction elements as per provisions for this Code.
- ¹ Materials having a structural base of non-combustible materials as defined in this Code, and having a surface not over 3.2 mm thick which when tested in accordance with the provisions of this Code has a flame spread rating not higher than 50 (fifty).
- ² Materials which when tested in accordance with the provisions of this Code have a surface flame spread rating not higher than twenty five without evidence of continued progressive combustion, and which are of such composition that surface which would be exposed by cutting through the material in any way would not have a flame spread ratings higher than twenty-five without evidence of continued progressive combustion.
- ^j Applies to the construction of the street floor and all construction below the level of the street floor in building or spaces classified in occupancy group A-3 except where the space below the street floor does not exceed five feet in height.
- ^k Columns supporting the roof of a one-story building shall have the same fire-resistance rating as required for a column supporting one floor in a building of the same construction class.
- ^l Members supporting loads of not more than two floors or one floor and a roof need not have a fire-resistance rating greater than the floor construction fire-resistance requirement in buildings classified in occupancy groups B, C and A-3, not including unsprinklered spaces of other occupancies, and in fully sprinklered buildings in occupancy groups E and A-5.

3.1.3.3 Construction Type II-C

This Construction type includes buildings and portion thereof in which

- (a) Exterior walls, fire walls, exit ways, and shaft enclosures are of non-combustible materials having the required fire-resistance ratings; and
- (b) The floors, roofs and interior framing are wholly or partly of wood of smaller dimensions than required for type II-A construction, or are of other combustible or non-combustible materials, having no required fire-resistance rating.

3.1.3.4 Construction Type II-D

This Construction type includes buildings and portion thereof in which exterior walls, bearing walls, floors, roofs, and interior framings are generally of wood or other combustible materials having the required fire-resistance ratings.

3.1.3.5 Construction Type II-E

This Construction type includes buildings and portion thereof in which

- (a) The exterior walls are generally of wood or other combustible materials having the required fire-resistance ratings, and
- (b) In which the bearing walls, floors, roofs, and interior framing are of wood or other combustible materials, generally having no fire-resistance ratings.

3.1.4 Separated Occupancy and Construction

When two or more occupancies accommodated in a building, each such occupancy shall be separated according to the provisions specified in Sec 2.3 Chapter 2 Part 3 and Table 3.2.1.

When two or more types of construction used within a building, the entire building shall be subject to the most restrictive construction type and shall comply with FAR restrictions as per provisions of this Code.

However if the Occupancies within the different Types of Construction are completely separated by construction that meets the fire-resistance rating requirements for fire separation listed in Table 3.2.1 of Chapter 1 Part 3 then each Occupancy so separated may, for the purpose of this Code, be considered as separate building section.

3.1.4.1 Restriction for mixed construction

In buildings of mixed construction, no structural element shall be supported by construction having a lower fire-resistance rating than that required for the element being supported.

3.1.5 Fire Zones

The planning and development authority of the city, township, municipality or region where this Code is intended to be implemented shall divide the area under their jurisdiction into distinct fire zones. The basis for this zoning shall be the fire hazard inherent in the buildings and the degree of safety desired for the occupancy accommodated therein. The number of zones in an area shall depend on its size and the strategies undertaken for its development.

3.1.5.1 Fire Zone 1

The following occupancy groups shall comprise this zone:

Occupancy A: Residential	Occupancy F: Mercantile
Occupancy B: Educational	Occupancy H: Livestock Storage Building
Occupancy C: Institutional for Care	Occupancy I: Assembly
Occupancy D: Health Care	Occupancy K: K1 and K2 Parking
Occupancy E: Offices	Occupancy M: Miscellaneous Buildings

3.1.5.2 Fire Zone 2

The following occupancy groups shall comprise this zone:

Occupancy G: Industrial Buildings

Occupancy H: Storage Buildings

Occupancy K: K3 Parking

3.1.5.3 Fire Zone 3

The only occupancy falling in this zone shall be Occupancy J, Hazardous Buildings.

3.1.5.4 Change in Fire Zone Boundaries

The demarcations of fire zones may be changed or new occupancies may be included in any fire zone through the same procedure as for promulgating new rules or ordinances or both.

3.1.5.5 Buildings on overlapping fire zones

Buildings falling on more than one fire zones shall be considered to be situated on the zone in which the major portion of the building falls. If a building is divided equally between more than one fire zones, it shall be considered as falling in the fire zone having more hazardous occupancy buildings.

3.1.5.6 Restrictions on temporary constructions

Permission may be granted by the Authority for temporary constructions only in fire zones 1 and 2 and not in fire zone 3. Such temporary constructions shall adhere to the conditions of the permission and shall be demolished and removed completely after the expiry of the duration of the permission unless it is extended by the Authority or a new permission is obtained.

3.1.6 Permissible Types of Construction for Various Occupancies

3.1.6.1 New buildings

Types of constructions permitted for various buildings on the basis of fire zones are specified in Table 3.2.4.

3.1.6.2 Existing buildings

Existing buildings in any fire zone need not comply with the provision of this Code for type of construction unless they are altered or in the opinion of the Authority they constitute a hazard to the safety to the occupants of the buildings or the adjacent properties.

3.1.7 Exterior Walls

The fire resistance rating of the exterior walls shall conform to the provisions set forth in Table 3.2.2 and Sec 3.2.3.

3.1.8 Basement Floor

Basement floor of a building shall be enclosed with a one hour fire resistive construction. Doors in such constructions shall be made of noncombustible materials.

3.1.9 Restricting Horizontal and Vertical Spread of Fire

Generally walls restrict horizontal movement and slabs restrict vertical movement of fire.

3.1.9.1 Interior or barrier or enclosure wall

Propagation of fire, smoke, gas or fume through the openings or shafts or penetrations of fire resistive floors and walls shall be restricted by sealing with an approved material which shall have a fire resistance rating at least equal to that of the floor-wall assembly. The sealing material shall be capable of preventing passage of flame and hot gases sufficient to ignite cotton waste when tested in accordance with ASTM E119.

3.1.9.2 Exterior walls

Permitted unprotected openings in the exterior wall in two consecutive floors lying within 1.5 m laterally or vertically shall be separated with flame barriers as similar as sunshades or cornices or projected wall at least 750 mm from the external face of the exterior wall. The flame barrier shall have a fire resistance rating of not less than three-fourths hour.

3.1.10 Exceptions to Fire Resistance Requirements

The provisions of this Section are exceptions to the occupation separation requirements of Table 3.2.1.

3.1.10.1 Fixed partitions

- (a) Stores and Offices: In such cases where offices, stores and similar places occupied by one tenant are separated by non-load bearing walls that do not form a corridor serving an occupant load, the partition walls may be constructed of any one of the following:
- (i) Noncombustible materials;
 - (ii) Fire retardant treated wood;
 - (iii) One hour fire resistive construction;
 - (iv) Wood panels or similar light construction up to three fourths the height of the room in which placed; and
 - (v) Wood panels or similar light construction more than three-fourths the height of the room in which placed with not less than upper one fourth of the partition constructed of glass.

- (b) Hotels and Apartments: In such cases where non-load bearing walls act as interior partitions in individual dwelling units in apartment houses and guest rooms or suites in hotels when such dwelling units, guest rooms or suites are separated from each other and from corridors by not less than one-hour fire-resistive construction, the partition walls may be constructed of any one of the following:
- (i) Noncombustible materials of fire retardant treated wood in buildings of any type of construction; or
 - (ii) Combustible framing with noncombustible materials applied to the framing in buildings of Type II construction.
- (c) Folding, Portable or Movable Partitions: Folding, portable or movable partitions need not have a fire resistance rating if the following conditions are satisfied:
- (i) Required exits are not blocked without providing alternative conforming exits;
 - (ii) Tracks, guides or other approved methods are used to restrict their locations; and
 - (iii) Flammability shall be limited to materials having a flame-spread classification as set forth in Table 3.3.2 for rooms or areas.

Table 3.3.2: Flame Spread Classification

Class	Flame Spread Index
I	0-25
II	26-75
III	76-200

- (d) Walls Fronting on Streets or Yards: For walls fronting on a street or yard having a width of at least 12 m, certain elements of the wall may be constructed as follows regardless of their fire-resistive requirements:
- (i) Bulkheads below show windows, show window frames, aprons and show-cases may be of combustible materials provided the height of such construction does not exceed 5 m above grade.
 - (ii) Wood veneer of boards not less than 25 mm in nominal thickness or exterior type panels not less than 10 mm in nominal thickness may be used in walls provided:
 - the veneer does not extend beyond 5 m above grade; and
 - The veneer is placed either directly against noncombustible surface or furred out from such surfaces not to exceed 40 mm with all concealed spaces fire blocked.

- (e) Trim: Wood may be used to construct trim, picture moulds, chair rails, baseboards, handrails and show window backing. If there is no requirement for using fire protected construction, unprotected wood doors and windows may be used.
- (f) Loading Platform: Noncombustible construction of heavy timber may be used for exterior loading platforms with wood floors not less than 50 mm in nominal thickness. Such wood construction shall not be carried through the exterior walls.
- (g) Insulating Boards: Combustible finished boards may be used under finished flooring.

3.1.11 Shaft Enclosures

3.1.11.1 General

Construction requirement for shafts through floors shall conform to the provisions of Tables 3.3.1 (a) and (b).

3.1.11.2 Extent of enclosures

Shaft enclosures shall extend from the lowest floor opening through successive floor openings and shall be enclosed at the top and bottom.

Exceptions:

- (a) Shafts need not be enclosed at the top if it extends through or to the underside of the roof sheathing, deck or slab.
- (b) Noncombustible ducts carrying vapours, dusts or combustion products may penetrate the enclosure at the bottom.
- (c) Shafts need not be enclosed at the bottom when protected by fire dampers conforming to "Test Methods for Fire Dampers and Ceiling Dampers", installed at the lowest floor level within the shaft enclosure.

3.1.11.3 Special provision

In groups other than Occupancies C and D, openings which penetrate only one floor and are not connected with any other floor or basement and which are not concealed within building construction assemblies need not be enclosed.

3.1.11.4 Protection of openings

Openings in shaft enclosures shall be protected with a self-closing or an automatic-closing fire assembly having a fire resistance rating of

- (a) one hour for one hour fire resistive walls
- (b) one and one-half hours for two hour fire resistive walls

3.1.11.5 Rubbish and linen chute termination rooms:

Rubbish and linen chute shall terminate in rooms separate from the remaining of the building having the same fire resistance as required for shafts in Table 3.3.1 (a) and (b) but not less than one hour.

3.1.12 Expansion and Contraction Joints

Expansion and contraction joints provided to accommodate expansion, contraction, wind or seismic movement shall be protected with an approved material having the same degree of fire resistance as that of the wall or floor in which it is installed.

3.1.13 Weather Protection

3.1.13.1 Weather resistive barrier

All weather exposed surfaces shall have a weather barrier to protect the interior wall from dampening. Such weather barriers shall have a fire resistance rating of at least equal to that of the wall or floor on which it is applied. Weather resistive barrier need not be used in the following cases:

- (i) When exterior covering is of approved waterproof panels
- (ii) In back plastered construction
- (iii) When there is no human occupancy
- (iv) Over water repellent panel sheathing
- (v) Under approved paper backed metal or wire fabric lath
- (vi) Behind lath and Portland cement plaster applied to the underside of roof and eave projections

3.1.13.2 Flashing and counter flashing

Exterior openings exposed to the weather shall be flashed to make them weather proof. There shall be copings with all parapets. Corrosion resistant metals shall be used for flashing, counter flashing and coping.

3.1.13.3 Waterproofing weather-exposed areas

Waterproofing shall be applied to exposed surfaces like balconies, external stairways and landings.

3.1.13.4 Damp-proofing foundation walls

Outside of foundation walls enclosing a basement floor below finished grade shall be damp-proofed from outside.

3.1.14 Members Carrying Walls

All members carrying masonry or concrete walls shall be fire protected as specified in Table 3.3.1 (a) and (b).

3.1.15 Parapets

Parapets constructed on exterior wall of a building shall have the same degree of fire resistance required for the wall upon which they are erected and there shall be noncombustible faces on the side adjacent to the roof surface for the uppermost 405 mm including counter flashing and coping materials. The height of the parapet shall be at least 750 mm from the upper surface of the roof.

3.1.16 Projections

Sunshades, cornices, projected balconies and overhanging beyond walls of Type I construction shall be of noncombustible materials. Projections from walls of Type II may be of combustible or noncombustible materials.

3.1.17 Guards and Stoppers**3.1.17.1 Guards**

Guards or Guardrails shall be provided to protect edges of floor, roof, roof openings, stairways, landings and ramps, balconies or terraces and certain wall, which are elevated more than 750 mm above the grade and as per provisions of this Code.

3.1.17.2 Stoppers

Stopper shall be provided in open parking garages located more than 450 mm above the adjacent grade or back to back parking stall. The height of the stopper shall be at least 300 mm and it shall be positioned at outer edges of a car parking stall.

3.1.18 Insulation

The provisions of this Section are applicable to thermal and acoustical insulations located on or within floor-ceiling and roof ceiling assemblies, crawl spaces, walls, partitions and insulation on pipes and tubing.

Materials used for such insulation and covering shall have a flame spread rating not more than 25 and a smoke density not more than 450.

3.1.19 Atrium**3.1.19.1 General**

Atrium may be provided in all groups other than Occupancy J (Hazardous Buildings). Such atrium shall have a minimum opening and are as specified in Table 3.3.3. A vertical opening serving as other than an exit enclosure connecting only two adjacent stories shall be permitted to be open to one of the two stories.

Table 3.3.3: Atrium Opening and Area

Height in Stories	Minimum Clear Opening ¹ (m)	Minimum Area (m ²)
2-4	6	40
5-7	9	90
8 or more	12	160

¹ The specified dimensions are the diameters of inscribed circles whose centers fall on a common axis for the full height of the atrium.

3.1.19.2 Smoke control system

A mechanically operated air-handling system shall be installed to exhaust the smoke either entering or developed within the atrium.

- (a) Exhaust Openings: The location of the exhaust openings shall be in the ceiling or in a smoke trap area immediately adjacent to the ceiling of the atrium above the top of the highest portion of door openings into the atrium.
- (b) Supply Openings: Supply openings designed for a minimum of 50 percent of the exhaust volume shall be located at the lowest level of the atrium. Supply air may be introduced by gravity provided the height of the atrium is not more than 18 m and smoke control is established. For atria having height greater than 18 m, supply air shall be introduced mechanically from the floor of the atrium and directed vertically toward the exhaust outlets. Supplemental air supply may be introduced at upper levels in atrium over six storeys in height or when tenant spaces above the second storey are open to the atrium.
- (c) Automatic Operation: The smoke control system for the atrium shall be activated automatically by the automatic sprinkler system or smoke detectors installed within the atrium or areas open to the atrium.
- (d) Manual Operation: The smoke control system shall also be manually operable for use by the fire department. The smoke control system may be separate from or integrated with other air handling systems. Air handling systems interfering with the smoke control system shall be shut down automatically when the smoke control system is activated.
- (e) Smoke Detector Location: Smoke detectors which will automatically operate the smoke control system of the atrium shall be accessible for maintenance, testing and servicing. Their locations shall be as follows:
 - (i) At the atrium ceiling, spaced in accordance with the manufacturer's instructions.
 - (ii) On the underside of projections into the atrium, in accordance with the manufacturer's instructions.

-
- (iii) Around the perimeter of the atrium opening on all floors open to the atrium. These detectors shall be spaced no more than 9 m on centre and shall be located within 5 m of the atrium opening.
 - (iv) If projected beam type smoke detectors are used, they shall be installed in accordance with manufacturer's instructions.
 - (f) Enclosure of Atrium: Atria shall be separated from the adjacent spaces with fire resistive separation of at least one hour.

Fire windows may be provided in fixed glazed openings when the window has a fire resistive rating of at least three-fourths hour and the area of the opening does not exceed 25 percent of the wall common to the atrium and the room into which the opening is provided.

3.1.20 Mezzanine Floors

Construction of a mezzanine floor shall conform to the requirements of the main floor in which it is constructed but the fire resistance rating need not exceed one hour for unenclosed mezzanines.

PART III
Chapter 4
Energy Efficiency and Sustainability

4.1 Scope

The purpose of including this Chapter in the Code is to enhance the design and construction of buildings through the use of building concepts having a positive environmental impact and encourage sustainable construction practices, allowing efficiency and conservation of energy, water and building materials, and to promote resource efficiency.

In addition to the clauses stipulated here, all Codes and standards relevant to a building occupancy as set forth in other Sections of this Code will be applicable during implementation.

Design and drawings will be submitted to indicate the location, nature and scope of the proposed energy efficient/sustainable feature. These shall indicate compliance to the provisions of this Code, and will be supplied by the relevant design professionals, e.g. electrical engineers, mechanical engineers, plumbing engineers, etc., supporting architectural drawings.

4.1.1 Rationale for Sustainable/Green Buildings

Climate change is an established phenomenon affecting the environment globally and it is recognized that buildings and the built environment play a vital role in the process, impacting on the natural environment and the quality of life. Sustainable development concepts and approaches applied to the design, construction and operation of buildings or to any built environment can enhance both the economic and environmental benefits of the community in Bangladesh and around the world. Energy efficiency and sustainability is not an individual issue rather an integrated and inseparable part of the building design and construction process. The benefits of sustainable design principles include resource and energy efficiency, healthy buildings and materials, ecologically and socially sensitive land use and strengthened local economics and the communities, objectives vital for future development of Bangladesh.

4.2 Definitions

DAYLIGHT ZONE	An area with a depth of 5m parallel to any glazed external wall.
EMERGENCY LIGHTING	Lighting used for emergency spaces and functions, e.g. in fire stairs, for egress path signage.
GREY WATER	Waste water generated from wash hand basins, showers and baths, Grey water often excludes discharge from laundry, dishwashers and kitchen sinks due to the high nutrient levels. It differs from the discharge of WC's which is designated sewage or black water to indicate it contains human waste.
REGULARLY OCCUPIED SPACE	All the main areas in the buildings that are used on a frequent basis, such as living rooms, bedrooms, classrooms, lobbies, meeting rooms, hall rooms and office spaces. Service spaces like toilets, bathrooms, corridors and stores will not be considered as frequently occupied areas.
WINDOW TO WALL RATIO OF BUILDING (WWRB)	The window-to-wall ratio of a building is the percentage of its facade taken up by light-transmitting glazing surfaces, including windows and translucent surfaces such as glass bricks. It does not include glass surfaces used ornamentally or as cladding, which do not provide transparency to the interior. Only facade surfaces are counted in the ratio, and not roof surfaces.
LIGHTING POWER DENSITY (LPD)	Average total lighting power installed divided by the total occupied area.
SHADING COEFFICIENT (SC)	The ratio of solar heat gain at normal incidence through glazing to that occurring through 1/8 inch thick clear, double-strength glass. Shading coefficient, as used herein, does not include interior, exterior, or integral shading devices.
SOLAR HEAT GAIN COEFFICIENT (SHGC)	An indicator of glazing performance is the amount of heat admitted through the glass vis-à-vis the total heat incident on the glass by virtue of direct solar radiation. The unit is a simple fraction or percentage.

U-VALUE (THERMAL TRANSMITTANCE)	Heat transmission in unit time through unit area of a material or construction and the boundary air films, induced by unit temperature difference between the environments on each side. Units of U-value are $W/m^2/°k$
VISIBLE LIGHT TRANSMITTANCE (VLT)	Amount of light transmitted through glazing, expressed as a simple fraction or percentage

4.3 Site Sustainability

This Section deals with sites to ensure energy efficiency through passive and low energy architectural features and management of resources.

4.3.1 Mandatory Unpaved Area

Fifty (50) percent of mandatory open space shall be permeable on sites of all occupancy categories. The permeable area shall not remain bare generating dust, but will have green cover or be treated with perforated paving ($\geq 50\%$), organic mulch, charcoal, etc.

4.3.2 Site Drainage and Run-Off Coefficient

Designs shall indicate site drainage considerations along with flash flooding and erosion prevention measures for sites above 1340 m^2 in area. As excessive paving is largely responsible for fast water run-off and flash flooding, design shall indicate measures taken to make paving permeable. The net run-off from a site shall be a maximum of sixty (60) percent. The following method will be used for the calculations, in conjunction with Table 3.4.1:

$$\text{Total Perviousness on Open Area of Site (A}_p\text{)} = A_1 \times C_1 + A_2 \times C_2 + \dots \quad (3.4.1)$$

Where, A_1 , A_2 , etc., being the areas of various surfaces, e.g. Pavements, roads, vegetation, etc., with different run-off coefficients C_1 , C_2 , C_3 etc., shown in the Table 3.4.1.

4.3.3 Vegetation Plan

For sites above three (3) acres, it is mandatory for a vegetation plan to be submitted along with the site plan and Irrigation Plan, where priority shall be given to native plants in the selection for planting.

4.3.4 Irrigation Plan

4.3.4.1 For sites above ten (10) acres, an irrigation plan with construction details shall be submitted with the site plan, where considerations shall include for management of rainwater.

4.3.4.2 For these sites a retention pond of $\geq 3\%$ of site area shall be provided. This shall include any existing natural water body within the site.

Table 3.4.1: Run-Off Coefficients of Various Surfaces

Surface Type	Run-Off Coefficient, C
Roofs, conventional	0.95
Green Roofs (soil/growing medium depth \geq 300 mm)	0.45
Concrete paving	0.95
Gravel	0.75
Brick paving	0.85
Vegetation:	
1-3%	0.20
3-10%	0.25
>10%	0.30
Turf Slopes:	
0-1%	0.25
1-3%	0.35
3-10%	0.40
>10%	0.45

4.3.5 Rain Water Harvesting System

4.3.5.1 Buildings of total floor area \geq 4000 m² shall have its own rain water harvesting system as discussed in Chapter 7 Part 8 and installed complying with Section 7.13 Part 8, of this Code. The reservoir capacity shall be a multiple of the area of Ground Coverage of the building and a rain collection coefficient of 0.073.

4.3.5.2 The rainwater reservoir may be placed under the roof or at lower levels, including underground.

4.4 BUILDING ENVELOPE

4.4.1 Window to Wall Ratio

4.4.1.1 For mechanically ventilated and cooled buildings of all occupancies, other than Hazardous and Storage, the Window to Wall ratio of building (WWRB), will be determined in conjunction with the glazing performance, as indicated by the Solar Heat Gain Coefficient (SHGC) or Shading Coefficient (SC) of the glass used. The relationship is given in Figure 3.4.1 and Table 3.4.2.

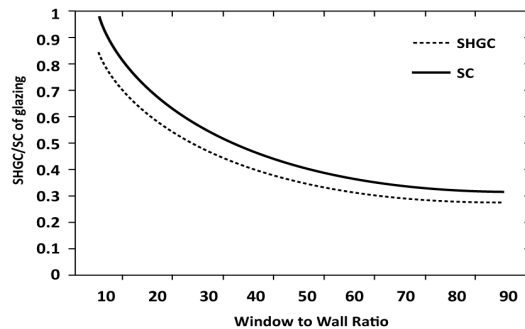


Figure 3.4.1 Selection of glazing SHGC based on WWR

Table 3.4.2 Selection of Glazing SHGC Based on WWR in Tabular Format

WWR	SHGC	SC
10	0.85	0.98
20	0.6	0.69
30	0.5	0.57
40	0.4	0.46
50	0.35	0.4
60	0.33	0.38
70	0.31	0.36
80	0.3	0.34
90	0.27	0.31

4.4.1.2 In all of the above cases, the Visible Light Transmittance (VLT) of the glazed element shall not be lower than thirty five (35) percent.

4.4.1.3 For Air-conditioned buildings with external shading, permitted SGHC limit may be adjusted, but the increase shall not exceed values determined by Eq. 3.4.2 below:

$$SHGC_{adj} = SHGC + A \quad (3.4.2)$$

Where,

$SHGC_{adj}$ is the adjusted solar heat gain coefficient limit for windows with shading

$SHGC$ is the solar heat gain coefficient from Table 3.4.2

A is the SHGC correction factor for the external shading as per Table 3.4.3 or Table 3.4.4: For a window with overhang and fin, the value of A can be only used either from overhang or from fin.

4.4.1.4 For naturally ventilated buildings, window size shall be based on Sec 4.4.2. Window Openings of this Code and shading shall be provided as per Sec 4.4.3.

4.4.1.5 Window size shall under no circumstances be less than as stipulated under Part 3: Chapter 1, Section 1.17 of this Code.

Table 3.4.3: Correction Factor against Overhang Shading Projection Factor

Overhang Projection Factor	SHGC Correction Factor(A)
0.0	0.00
0.1	0.05
0.2	0.09
0.3	0.14
0.4	0.19
0.5	0.24
0.6	0.28
0.7	0.33
0.8	0.38
0.9	0.43
1 or higher	0.47

Projection factor for overhang is the depth of the overhang divided by the height of the window

Table 3.4.4: Correction Factor against Vertical Shading (fins) Projection Factor

Vertical Shading (Fins) Projection Factor	SHGC Correction Factor (A)
0.0	0.00
0.1	0.04
0.2	0.08
0.3	0.12
0.4	0.16
0.5	0.20
0.6	0.24
0.7	0.28
0.8	0.32
0.9	0.36
1 or higher	0.40

Projection factor of fins is the depth/length of fin divided by the width of the window.

4.4.2 Window Openings

Mechanically ventilated and cooled buildings of all occupancies, other than hazardous, retail and storage, shall have the provision of using natural ventilation for cooling and fresh air, in frequently occupied areas, with a fraction $\geq 4\%$ of the floor area being specified as openable windows. Openable balcony doors can be counted in this calculation. Note if the window area defined under Sec 4.4.1 is less than openable area, then fifty (50) percent of window area should be openable.

4.4.2.1 Naturally ventilated buildings of all occupancies, other than hazardous and storage, shall provide for fifty (50) percent of its window area to be openable.

4.4.2.2 All the openable windows above ground should be designed with safety measures in place such as protection hand rails for child safety.

4.4.2.3 Windows to any regularly occupied space on exterior walls in naturally ventilated buildings shall be shaded conforming to Sec 4.4.3.

4.4.3 Shading

4.4.3.1 For naturally ventilated buildings of all occupancies, horizontal sunshades shall be provided over windows on South, East and West, the depth of which shall be calculated by multiplying the window height with a factor of 0.234 (Figure 3.4.2). Horizontal louvers can be used instead of sunshades, in which case, depth of louver shall not be less than 0.234 times the gaps between the louvers (Figure 3.4.3).

4.4.3.2 Vertical Shading devices shall be provided on the West, depth of which shall be calculated, by multiplying the gaps between the vertical fins, or the window width if the shades border the window width, with a factor of 0.234 (Figure 3.4.4).

Exceptions:

- (a) The above rule shall be relaxed if it can be demonstrated that shading is achieved by existing neighbouring structures.
- (b) The north side of all buildings are exempt from the above rules.

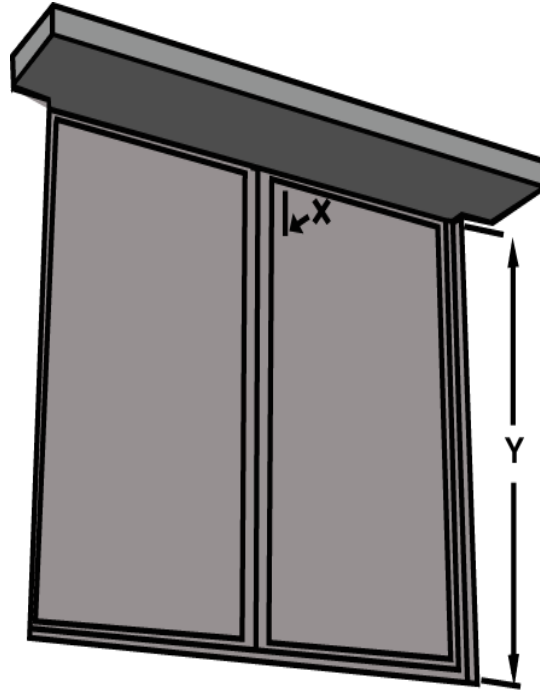


Figure 3.4.2 Horizontal shade: $x \geq 0.234y$

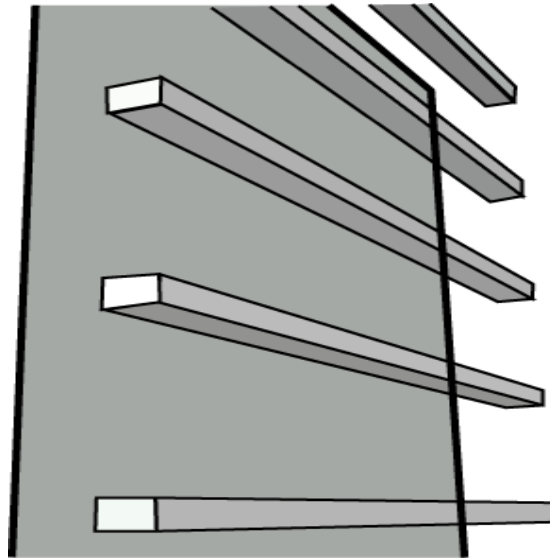


Figure 3.4.3 Horizontal Louvres: relationship between depth (x) and gap (y): $x \geq 0.234y$

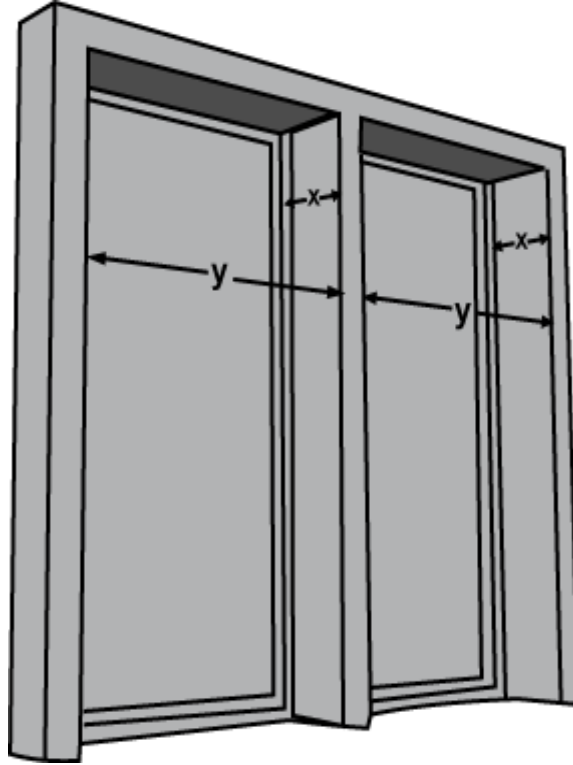


Figure 3.4.4 Vertical shading or louvres: relationship between depth (x) and gap (y): $x \geq 0.234y$

4.4.4 Roof Insulation and Green Roofing System

4.4.4.1 Fifty (50) percent of horizontal exposed roof slabs of Buildings of Occupancy B, C, D and E, shall have green roofing system, to manage water run-off from roof tops, to control internal temperatures within the top floors and to reduce the carbon footprint of the building. This shall not include any covered roof surface, e.g. solar panels, solar thermal heaters, machinery for mechanical or electrical systems, water tanks, etc. Stair loft or machine room tops will be exempt from this rule.

- (a) The roof slab design shall consider structural support of the green roof system, with growing medium of minimum 300 mm.
- (b) The design will indicate protection from dampness and provide a drainage system

4.4.4.2 Horizontal roof slabs, which are not covered by green roofing system, will have roof slabs with insulation, so that the time lag and decrement factor is greater than the other floor slabs of the building.

4.5 Energy Efficient Building Systems

4.5.1 Daylighting and Supplementary Lighting System

4.5.1.1 Window area shall not be less than 14 percent or 1/7th of the total floor area of the building.

4.5.1.2 Every regularly occupied space shall contain a minimum percentage of day-lit area along the building perimeter zones, with no window less than an area of 1 m² and will ensure the appropriate stipulations given below.

- (a) for rooms that measure less than 8 m in depth, window area shall be at least 20 percent of the area of the external wall of the room.
- (b) for rooms that measure between 8 to 14 m in depth, window area shall be at least 30 percent of the area of the external wall of the room and 35 percent of the external wall.
- (c) for rooms that measure more than 14 m in depth, window area shall be at least 35 percent of the area of the external wall of the room.

4.5.1.3 For Buildings of Occupancy A5, B, C, E1 and E2, photoelectric sensors shall be connected to luminaires, to enable dimming or switching off lamps that do not require to be operated, due to the presence of adequate daylight. The photoelectric sensor shall be located approximately at half (½) the depth of day-lit zone.

4.5.1.4 If occupancy sensors are installed in the daylight area, the occupancy sensor shall override the daylight sensor during non-occupancy period.

Exceptions:

- (a) Zones with special requirements are exempt from the stipulation of Sec 4.5.1.3. The designer shall justify the reason for exemption.
- (b) Hotel guest rooms are exempt.

4.5.2 Lighting Power Density

4.5.2.1 Lighting Power Density (LPD) of the values set in Table 3.4.5 shall be provided for the respective functions within all building occupancies, or as specified.

4.5.2.2 In addition to Sec 4.5.2.1, Illumination values (Lux) as specified in Tables 8.1.5 to 8.1.14 of Part 8 of this Code shall be provided for buildings of the respective occupancies.

4.5.3 Occupancy Sensors

4.5.3.1 In order to limit the use of electricity in the unoccupied areas of buildings, occupancy sensors linked to lighting (except for emergency and security lighting) shall be installed in the public areas of buildings of occupancies specified in Table 3.4.6.

Table 3.4.5: Maximum Allowable Lighting Power Density for Different Occupancies

Occupancy		Maximum LPD (W/m ²)
E1 and E2	Offices	9
F1 and F2	Retail/Mercantile	13
A5	Hotels	9
D1	Hospitals	11
A1, A2 and A3	Apartments/residences	7
B	Educational	11
All occupancies	Covered parking*	3
All occupancies	Open/outdoor parking	1.6

* LPD for car parks shall calculated from the total lighting power divided by the total car park area

Table 3.4.6: Applicability of Occupancy Sensors

Occupancy		Applicability
E1 and E2	Offices	Meeting rooms and corridors
A5	Hotels	Meeting rooms and corridors
A3	Apartments	Covered car parks and corridors
B	Educational	Covered car parks and corridors

4.5.3.2 For car parks a minimum 2/3rd of the lighting shall be controlled by occupancy sensors.

4.5.3.3 Emergency lighting shall not be connected to occupancy sensors.

4.5.4 Ceiling/ Wall Mounted Fans

4.5.4.1 For naturally ventilated buildings of occupancy A, ceiling/wall mounted fans shall be provided in each regularly occupied space.

4.5.4.2 For buildings of occupancy B, C, D, E and I, ceiling/wall mounted fans shall be provided in each room larger than 25 m², with a minimum of one fan every 25 m².

Exceptions:

- (a) Corridors of buildings of all occupancies
- (b) ICU, CCU, operating theatres of Hospitals and Clinics

4.5.5 Lift and Escalator Efficiencies

4.5.5.1 Escalators, in buildings of all occupancies, shall be fitted with controls to reduce speed or to stop when no traffic is detected.

4.5.5.2 Such escalators shall be designed with one of the energy saving features as described in i or ii below:

- (i) Reduced speed control: The escalator shall change to a slower speed when no activity has been detected for a period of a maximum of three (3) minutes. Detection shall be by photocell activation at the top and bottom landing areas.
- (ii) Use on demand: The escalator shall shut down when no activity has been detected for a period of a maximum of fifteen (15) minutes, designed with energy efficient soft start technology. The escalator shall start automatically when required; activation shall be by photocells installed in the top and bottom landing areas.

4.5.5.3 Elevators (lift) in buildings of occupancy A5, D1, E1, E2, F1, F2, I1 and I3 occupancies shall be provided with controls to reduce the energy demand, using the following features in traction drive elevators:

- (a) AC Variable-Voltage and Variable-Frequency (VVVF) drives on non-hydraulic elevators.
- (b) An average lamp efficacy, across all fittings in the lift car, of >55 lamp lumens/circuit watt, with provision for switching off, when lift is inactive for a period of a maximum of five (5) minutes.
- (c) The provision to operate in stand-by condition during off-peak periods, when the lift has been inactive for a period of a maximum of five (5) minutes.

4.5.6 Renewable Energy Options

4.5.6.1 Buildings of occupancy A shall use Solar or other renewable sources of energy to power 3% of the total electric load of the building, applicable to the uses in Sec 4.5.6.3.

4.5.6.2 Buildings of all occupancies other than A, shall use Solar or other renewable sources of energy to power 5% of the lighting and fan loads of the entire building, mandatory to uses in Sec 4.5.6.3.

4.5.6.3 For all occupancies, the solar or other renewable energy connection shall power spaces in the following order of priority: lighting in underground/basement spaces, dark corridors, supplementary lighting, fans, emergency lighting like fire stairs, emergency signage egress path lighting, etc.

4.5.7 Heating Ventilation and Air-conditioning (HVAC) System

For conditioned buildings, any Heating Ventilation and Air conditioning (HVAC) system planned for installation will meet energy efficiency standards specified in Part 8 of this Code.

4.6 Internal Water Management

4.6.1 Reuse of Grey Water

Buildings of occupancy A5, E1 and E2 and I shall reuse grey water for water efficiency and management.

Grey water from wash basin shall be reused in toilet flushing and/or irrigation after filtration to ensure a BOD (Biochemical Oxygen Demand) level <50. Such water shall not be considered potable.

4.6.2 Efficient Fittings in Toilets

Water efficient fittings, including faucets, showerheads and flushes, that use less water for the same function as effectively as standard models, shall be used in buildings of all occupancies. The low flow fixtures shown in Table 3.4.7 shall be used.

Table 3.4.7: Fixture Ratings

Type of Fixtures	Quantity (max)	Unit
Water closets	Dual Flush (6/4)	liters/flushing cycle (full/low)
Shower	9.5	liters/min at 551 kPa
Urinals	3	liters/flushing cycle
Hand wash taps	6	liters/min at 417.7 kPa
Kitchen/pantry faucets	6	liters/min at 417.7 kPa

4.6.3 Service Hot Water and Pumping

In order to reduce the energy used for water heating, buildings of occupancy A5 and D1 shall use solar hot water system to supply a minimum of thirty (30) percent of the total building hot water requirements. The solar hot water system can be flat plate solar collectors or vacuum tube solar system, this system must be designed and installed with the backup system or as a per heating for the main hot water system.

PART III
Appendix A
Planning and Development Control

A.1 Scope

In absence of planning and zoning code in the national level, this Appendix states certain planning guidelines for development control and for environmental and human safety. The guidelines formulated in this Appendix are suggestive.

A.2 Land Use Classification

Land is a finite resource. An integrated and hierarchical planning from national to local level of this resource is essential to identify and use its potential in compliance with the National Land Use Policy.

Every city, township, municipality or other settlements shall have planning and zoning regulations administered by the authority having jurisdiction to guide the existing and future developments of that settlement in compliance with the National Land Use Policy and with local or regional master planning. Any land-use planning shall clearly classify the following uses:

- (a) Permitted land use
- (b) Conditionally permitted land-use and
- (c) Restricted land use

Any such plan shall also include the preservation of open spaces and water bodies as part of the land use planning.

A.3 General Guidelines For Residential Density Planning

A.3.1 Control of residential density is a fundamental component of effective land use planning, as the relative distribution of population has major implications for all other provisions. In determining Residential density, a coherent view should be considered to achieve integrated land-use, transport, environmental and infrastructural planning.

A.3.2 Along with this integrated approach, the following factors shall also guide the residential density:

- (a) A hierarchy of residential densities should be maintained to ensure diversity of housing needs.
- (b) Residential density of an area shall correspond to the capacity of existing and planned infrastructure and environmental features of that area.

- (c) Densities should be planned in such a way that encourage public transport and reduce travel demand.
- (d) For large cities higher densities around stations and interchanges of rail based public transport system may be encouraged to reduce reliance on road based public transport system.
- (e) Since higher density residential development near high capacity transportation system creates pressure on urban land use planning, careful environmental planning with definitive environmental objectives shall be there for such instances.
- (f) To protect environmentally sensitive areas or areas of historical importance, a low density residential development should be proposed where and as necessary.
- (g) In heavily built up areas such as old towns, provision of Transfer of Development Rights (TDR) could be implemented to control over-crowding.

A.3.3 The maximum allowable density of a residential development shall be guided by the Planning Guidelines for a zone or area or locality or township which shall be prepared under and administered by the authority having jurisdiction. Floor Area Ratio (FAR) for any development shall comply with any such planning guidelines. Where such density guideline is not available, the maximum allowable density for a residential development shall be 175 units per hectare.

A.4 General Planning Guidelines For Open Space Requirements

In a high density context like ours, pressure on land is extreme. Preserving open spaces and maintaining environmental balance become a priority in this context. In any planning process, open space must be planned as a land use in its own right and not as the remainder after providing other land uses. The hierarchy of Recreational open spaces in planning settlements may be as following:

- (a) Local Open Space
- (b) Ward Open Space
- (c) Regional Open Space

Authorities having jurisdiction shall determine the extent of the terms ‘local’, ‘ward’ and ‘region’ on the basis of governance structure and the master planning for any particular area. However, in developing any area layout as specified in Sec A.5.2 of this Appendix, provisions for Local open space should be applicable. All open spaces in this hierarchy should act as a connected component of an open space network. The following paragraphs indicate few guidelines on location and space requirements for such open spaces.

A.4.1 Every locality should have Local Open Space which is required to meet primarily the passive recreational needs (e.g. outdoor sitting, jogging/ walking tracks, playgrounds for children etc.) of the population. Such spaces should be located either within the residential neighborhood or somewhere centrally to serve a wider area of more than one neighborhood. Considering the projected future population of a locality, a minimum requirement of 1 m² of Local open space per locality occupant should be allotted. Where possible such open spaces should be at least 500 m².

A.4.2 Every ward in a city or town or union should have Ward Open Space which is required to meet the active recreational needs (e.g. standard facilities for sports) and passive recreational needs of the ward population. Considering the projected future population of a Ward, a minimum requirement of 1 m² Ward Open Space per Ward occupant should be allotted. Where possible such open spaces should be at least 10,000 m² (1 hectare).

A.4.3 Every region should have Regional Open Space which is required to meet wider recreational needs of the population that cannot be served by local or ward open spaces. In metropolitan areas, Ward Open Space may supplement for 50 percent of the Regional Open Space requirement. Conscious planning effort are needed to create/ designate and/ or preserve 'Regional Open Spaces' located close to major public transport routes, taking advantage of natural landscape, waterfront, hill views, forest areas and/or views to special features that may draw visitors from all around. Where possible such open spaces should be at least 50,000 m² (5 hectare).

A.5 Community Open Space And Amenities

Every plot as specified in Sections A.5.1 and A.5.2 shall have community open space which is required to meet primarily the passive recreational needs (e.g. outdoor sitting, jogging/walking tracks, playgrounds for children etc.) of the population. Such spaces shall be located within the plot boundary. Considering the types of development, the following minimum requirements of community open space and amenities shall be applicable as per guideline of Sections A.5.1 and A.5.2 of this Appendix.

A.5.1 Community Space for a Single Tall Building or Group of Buildings In a Plot

For all residential or residential-cum-business buildings having ten or more storeys, or for all plots on which more than one residential or residential-cum-business buildings are constructed, community built space at the rate of 5 percent of the total floor area shall be provided within the building for use of the occupants of the building solely. Roofs of such buildings shall not be considered as community open spaces.

For residential or residential-cum-business plots measuring more than 0.1 hectare, 10 percent of the area of land or 1 m² per occupant of the plot, whichever is larger, shall be left vacant to be used as children's playground. This playground shall be contiguous and shall have a length not exceeding 2.5 times its width. The playground may extend into the mandatory open space of the plot.

Open space and amenities for residential or residential-cum-business plots measuring more than 0.4 hectare shall be as per guidelines of Sec A.5.2 of this Chapter.

A.5.2 Community Open Space and Amenities in Area Layouts

(a) Residential or Business Areas

In dividing any land measuring a total of 0.4 hectares or more into residential or business plots, community open spaces and amenities shall be reserved for recreational, educational, health care and other purposes depending on the size of the population for which the layout is planned. For planning such open spaces and amenities the guidelines of Sec A.4 of this Appendix and Sec B.3 of Appendix B shall be applicable.

(b) Industrial Areas

In dividing any land measuring a total of 1 hectare or more into industrial plots, 5 percent of the total land area shall be reserved as amenity open space which shall be used as lawn, park or garden. The minimum size of such open space shall be 600 m². When the area of the open space exceeds 1000 m², the area of land in excess of 1000 m² can be used for the construction of buildings for banks, clinics, welfare centers and other common facilities for use of the persons working in the industries.

A.6 Plot Size

Plot divisions and plot sizes are part of integrated planning decision of detail area plan and shall be determined by the Area Development Authority having jurisdiction. Where no such guideline exists or yet to be undertaken, the following criteria mentioned in Sections A.6.1 to A.6.8 regarding plot size shall be applicable.

A.6.1 Residential Plots

- (a) For any future development, the minimum size of the plot for Occupancy A1, A2 and A3 shall be 66 m², 133 m² and 200 m² respectively.

The sizes of the plots and the corresponding minimum widths of road frontage of the plots shall be as specified in Table 3.A.1 provided that:

- (i) Plots accessible by link roads shall be considered to have a frontage equal to the width of the link road, and
- (ii) Plots of irregular shape abutting the road shall be considered to have a frontage equal to their average width parallel to the road.

- (b) The limitations of plot sizes and frontages imposed in Sec A.6.1 (a) above may be waived for approved affordable housing including site and service schemes. Guidelines governing the planning and design of such housing are given in Appendix B.
- (c) The minimum size of the plot for a group housing development scheme and other special requirements for group housing developments shall be as specified or approved by the respective city development authority.
- (d) For minimum standard transitional housing, government may allow smaller plots following the guidelines mentioned in Appendix B.

Table 3.A.1: Minimum Frontage of Residential Plot

Type of Residential Development	Plot Size (m ²)	Minimum Frontage (m)
Approved row type houses	66 (Minimum size)	4.5
	Over 66 to below 133	8
Semi-detached houses	133 (Minimum size)	8
	Over 133 to 200	8-10
	Over 200 to 267	10-12
	Over 267 to 334	12
Detached	Over 267 to 334	12
	Over 335 to 669	16
	Over 669	24

Note: For plot sizes larger than 133 m² detached house type may be allowed provided that the site frontage is 12 m or more

A.6.2 Plots for Educational Buildings

The minimum size of plot for educational buildings shall be based on occupant capacity and shall be at the rate of 4 m² per pupil or occupant. With exception for nursery school the minimum plot size required for educational purpose shall be 3950 m² (see Appendix B).

A.6.3 Plots for Assembly Halls, Theatres, Cinema

The minimum size of plot for assembly halls, theatres, cinema halls and other similar buildings where people gather for entertainment or other public functions shall be based on the seating capacity of the building and shall be at the rate of 3 m² per seat. Table 3.A.2 shows the minimum plot size for such function:

Table 3.A.2: Plot Sizes for Assembly Occupancy

Sub-Category	Nature of Use or Occupancy	Minimum Plot Size
I1	Large assembly with fixed seats (1000 seats or more)	3000 m ²
I2	Small assembly with fixed seats (less than 1000 seats)	3 m ² per seated person
I3	Large assembly without fixed seats (300 or more occupants)	900 m ²
I4	Small assembly without fixed seats (less than 300 seats)	3 m ² per seated person
I5	Sports facilities	Related to event and spectator capacity

A.6.4 Plots for Community Centers

The size of plot for rural or urban community centers shall be not less than 1300 m² and commensurate with the size of the community.

A.6.5 Business and Mercantile Plots

The minimum size of a business and mercantile plot shall be 200 m² and its road frontage width shall not be less than 10 m.

A.6.6 Industrial Plots

The minimum size of an industrial plot shall be 300 m² and its road frontage width shall not be less than 15 m.

A.6.7 Petrol Filling Stations

The minimum size of the plot for a petrol filling station without service bay or repair workshop shall be 500 m² and its road frontage width shall not be less than 30 m. The minimum size of the plot for a petrol filling station with service bay but without repair workshop shall be 1100 m² and its road frontage width shall not be less than 30 m.

A.6.8 Plots for Other Uses

The minimum sizes of plots for buildings for uses other than those mentioned in Sections A.6.1 to A.6.7 shall be as determined by the Authority having jurisdiction.

PART III
Appendix B
Guidelines for Minimum Standard Housing Development

B.1 General

B.1.1 Government bodies or public agencies may designate an area in the master plan for the development of Mass Housing Projects. Generally all such development shall be known as Minimum Standard Housing, which shall be broadly categorized into the following two categories: a) Minimum Standard Community Housing and b) Minimum Standard Transitional Housing. Requirements for master plan and dwelling units in such projects shall have special provisions depending upon the category of development mentioned above.

The guidelines of this Appendix cover the planning and the general building requirements of all such Minimum Standard Housing developments.

B.1.2 A minimum standard community housing is a housing that conforms to the basic minimum requirement regarding dwelling units, community and other facilities according to the provision of this Code. Requirements for community facilities in these housings shall depend upon the size and scale of the community (Sec B.4.2). Dwelling units in all such developments shall be classified as Occupancy A1, A2, A3 or Mixed Occupancy depending upon the type of development (Sec B.3) and degree of mixing with other occupancies within the same structure.

B.1.3 Minimum Standard Transitional Housings are housing facilities on a transient basis before providing its inhabitants with Minimum Standard Community Housing. Ensuring safety, health and sanitation requirements shall be the primary obligation for such housing. Since, it may not be convenient or practicable for the planning and dwelling units in such projects to be in full compliance with all the requirements of this Code, a few exemptions have been made for all such housings in the following Sections of this Appendix. All Transitional Housing, irrespective of its type of development shall be group housing. Dwelling units in a transitional housing shall be classified as Occupancy A3, A4 or Mixed Occupancy depending upon the type of development and degree of mixing with other occupancies within the same structure.

B.1.4 Only government bodies or public agencies should be responsible for planning the number and location of the settlements in an approved master plan following the density guidelines of Appendix A and the layout of units within the settlement. The guidelines of this Appendix regarding layout planning are applicable to government bodies or public agencies responsible for such planning.

B.1.5 The guidelines and requirements regarding design and construction of buildings for minimum standard housing in approved layouts are applicable to all government bodies, public agencies, private developers or individual owners who undertake such constructions.

B.2 Types Of Development

The development of minimum standard housing may be any one or a combination of the following types:

- (a) Single unit plots of row type housing
- (b) Multi-storied flats of row type housing
- (c) Block development as a group housing
- (d) Cluster housing, and
- (e) Site and service schemes

The guidelines for planning and general building requirements shall be applicable to all types of development of minimum standard housing unless exempted as mentioned in this Appendix.

B.2.1 Single Unit Plots of Row Type Housing

Row Type in a housing development is characterized by independent plotted developments for single family dwelling (A1) and shared community facilities. Along with single family detached and semi-detached dwelling, this type of dwelling is used to achieve low-densities in a settlement.

This type of development should be located away from high capacity public transportation system and should be characterized by high car ownership rate.

All such development shall comply with the provisions for parti-wall and general criteria for natural lighting and ventilation as described in Part 3 Chapter 1, Part 6 and Appendix E.

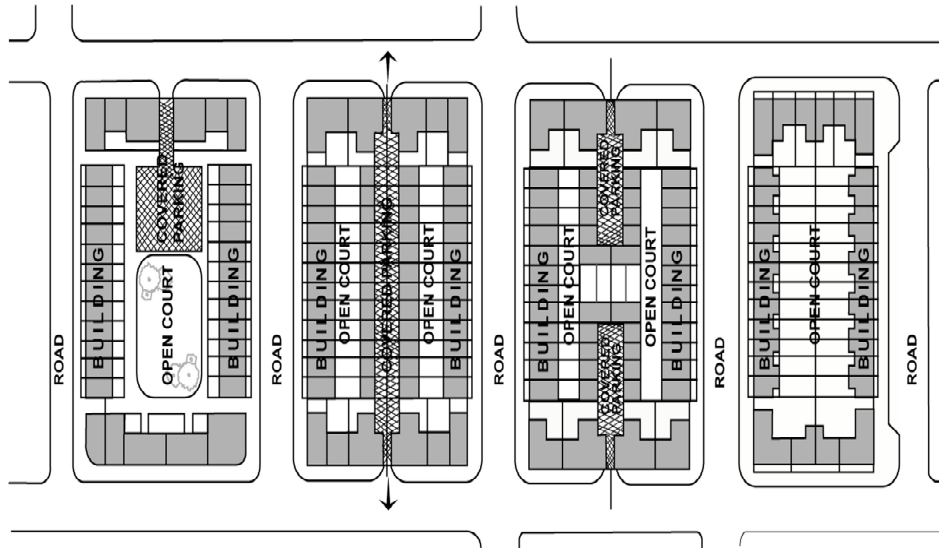


Figure 3.B.1 Row type development

B.2.2 Multi-Storied Flats of Row Type Housing

Unlike single unit plots of row type development, multistoried flats of row type housing are not plotted development. Here the un-demarcated un-divided land is shared by the flat owners within such complex.

Houses or flats or apartments in Multi-storied Row type developments shall share walls with adjacent flat or apartment, provided that they are designed and built at the same period as part of the same project and also that they fulfil the general criteria for natural lighting and ventilation as referred in Part 3, Chapter 1.

Multi-storied row type developments should be permitted for walkup apartments (A3) as well as two family dwelling (A2) with many of the community facilities at lower levels. Such developments are good for medium density settlements and may also be used in mixed use zones.

B.2.3 Block Development as a Group Housing

Block developments are characterized by high-density large scale developments within a block usually surrounded by roads all around and serviced by high capacity transport and utility network.

Large plots of 4048 m² or more, with road access on one side may also be considered as block development if provided with a peripheral access road along its perimeter and also if they are in close proximity to high capacity transport and utility infrastructure network. All such plots may be allowed to attain higher densities than other typologies. Such developments are more desirable in the central urban areas emphasizing more dependency on public transportation and less on private transportation. Parking requirements in such typologies shall be less than other typologies.

Block development for Group Housing should be permitted for large scale developments of Apartments (A3) or Mess, Boarding houses, Dormitories and Hostel (A4).

All such residential developments can be mixed with other permitted occupancies to encourage availability of all services within the close proximity and to support growth of local economy. All such developments can be subdivided into following two categories:

(a) Tower Block Development for Group Housing

This includes Flats or Apartments (A3) in a single or multiple high-rise towers within a block/large site with relatively low ground coverage and higher density along with open spaces and community facilities within and around the tower blocks.

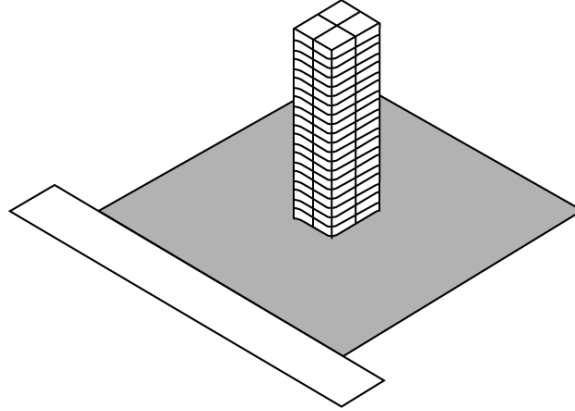


Figure 3.B.2 Tower block development

(b) Perimeter Block Development for Group Housing

Unlike Tower blocks, Perimeter block developments involves one single building or multiple buildings placed along the perimeter of the site to create an internal open space shielded from its surrounding, commonly used as community space. Each housing unit in such developments shall have at least two sides open—one at the internal open space and the other at the external road side.

Depending upon the plot size and population such development may also be permitted to become high-rise development, provided that the internal open space in such development confirms to the criteria for minimum requirements of a courtyard (Part 3, Chapter 1).

B.2.4 Cluster Housing

Cluster type development, as a housing form, is suitable for accommodating low to high density of population within walkup range. Cluster type development for Group Housing should be permitted for all ranges such as for low density development for single family dwelling (A1) and two family dwelling (A2) or for moderate to high density developments of Apartments (A3) or Mess, Boarding houses, Dormitories and Hostel (A4). Details of this typology have been discussed in Appendix D.

B.2.5 Site and Service Schemes

Site and service schemes shall delineate individual plots and provide for the infrastructural needs for the development of a permanent housing. Interim constructions by the allottees should also be permitted. Skeletal structures with a roof on columns and/or developed plinths may be provided if funds are available.

Sanitation and water supply must be provided in all site and service schemes. A sanitary service core or common water supply and sanitation facilities for planned groups of plots should normally suffice. The developing agency shall install the services before handing over the plots.

Site and service schemes for group housing should be permitted for low density development of single family dwelling (A1) and two family dwelling (A2) and ownership right of such housing shall be non-transferrable.

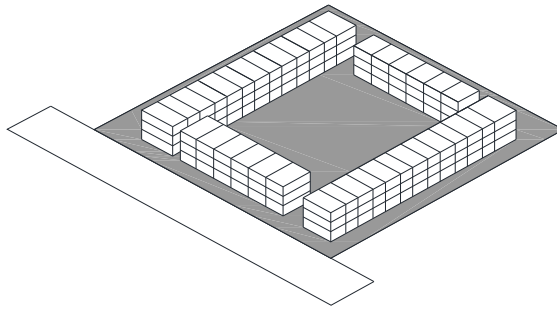


Figure 3.B.3 Perimeter block development

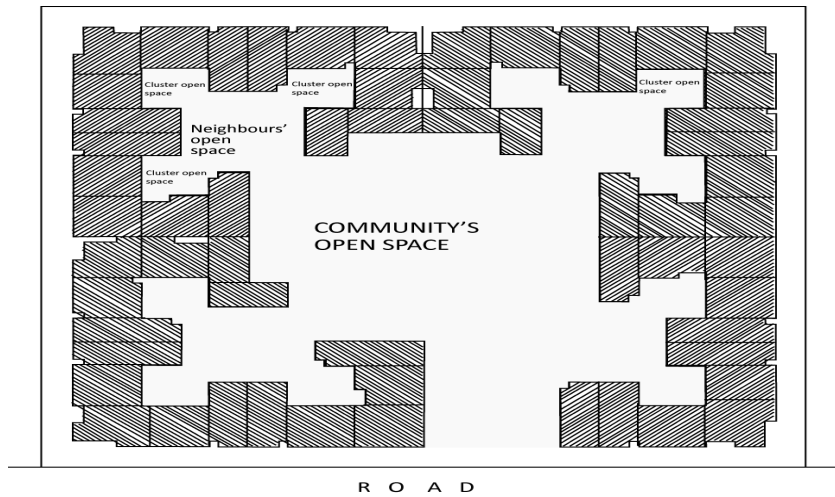


Figure 3.B.4 Cluster type development

B.3 Planning

B.3.1 A minimum standard housing shall ensure quality living for all its inhabitants. Providing proper environmental quality, social and utility infrastructure, educational facilities, health care and recreational facilities, connectivity to commerce and job locations in a comprehensive planning are pre-conditions to attain that. With increasing urban population and the shortage of developable land, high residential densities shall occur. This multiplies the necessity for the provision of community facilities to ensure the minimum standard of the housing.

B.3.2 Density

Housing density for an area or locality or settlement is a planning issue and shall be decided by the planning authority in accordance with the Detail Area Plan (DAP). Where such guidelines are unavailable, the gross density of a minimum standard housing shall not be more than 175 units per hectare, considering an average population of 5 persons per dwelling unit. The general distribution of built area and open space shall follow the provisions of Sec B.3.3.

B.3.3 Basic Requirements for Community Facilities and Facilities for Locality

Any minimum standard housing, irrespective of its type of development, should be planned and organized in groups or clusters, where each of the clusters should not exceed 400 dwelling units with an average population of 5 residents per dwelling. Where the number of dwellings is more than that, more than one clusters, each below 400 units, should be formed.

In any housing project, community and facilities for locality are essential. The facilities required for any such project shall depend on the size of the community or communities within a locality. Table 3.B.1 and Table 3.B.2 show the requirements of such facilities for any housing development in reference to their variation of net density and their relation to the threshold population.

B.3.3.1 Open space within a site area

Open space within a site area shall be as defined in Sec 1.8 Chapter 1, Part 3. However for a minimum standard housing, such open space shall also be equal or more than the open to sky space which is an outcome of addition of

- (a) Mandatory setback area and
- (b) Area requirement for Community Open Space (COS) as per Sec B.3.3.2.

For plots below 4048 m² community open space may overlap with mandatory setback area.

B.3.3.2 Community open space shall not be less than 1 m² per occupant.

B.3.3.3 Community facilities consist of two components :

(a) Community Open Space (COS) : Community open space is an undivided contiguous open space within a plot or block or cluster which along with mandatory setback area constitutes the open space of the site. Depending upon the size of population and land area this space may be used as any or combination of the following uses—

- (i) Lawn
- (ii) Garden
- (iii) Play lot

All such uses shall be exclusive to the residents of that plot or block or cluster.

No paved area, other than the minimum required area for vehicular and pedestrian access to the site, is allowed within this community open space. All such road and walkways shall ensure pedestrian priority and safety, and shall not be used as a through circulation.

The following guidelines shall be maintained if the area of the community open space within the site fulfils the criteria mentioned in the first column of Table 3.B.1.

(b) Community Built Space (CBS) : Community built space is part of the community facilities dedicated to serve the population within a given site or block or cluster. Depending upon the threshold population, the CBS shall include facilities as per guideline of Table 3.B.2 for a threshold population up to 200 families.

Table 3.B.1: Guideline for Minimum Width for Community Open Space

Open Space Area (m ²)	Minimum Width (m)	May Accommodate
130 or more	9	Badminton, table tennis etc.
700 or more	21	Basketball, badminton etc.

B.3.3.4 Facilities for Locality (FL) : Facilities for localities are shared facilities consisting of both Local Open Spaces (LOS) and Local Built Spaces (LBS) located outside the plot boundary but within the locality. The total space requirement of the Facilities for locality shall vary considerably depending upon the requirements of net density, gross density and threshold population of Table 3.B.2.

Table 3.B.2 refers to list of such facilities for a plot/locality/ward/region in relation to population size and space requirement for a settlement.

Table 3.B.2: Threshold Population and Minimum Reference Standard of Facilities for Community and Locality

Facilities	Threshold Population to Start the Facilities	Minimum Reference Standard	Level Served
General*			
Community Open Space (COS)	3 families	1 m ² per person	Plot
Management office	10 families	10 m ² room	Plot
Meeting room/hall (multi-purpose with storage and washroom facilities)	20 families	2 m ² / family	Plot
Indoor games room	30 families	1 m ² per family	Plot
Prayer hall	40 families	0.75 m ² per family	Plot
Educational			
Day care center**	100-300 families/500-1500 persons	Minimum 6 children	Plot/ local
Nursery/kindergarten school (age group 3 to under 6 years)**	400-600 families/2000-3000 persons	Minimum 6 classrooms	Local
Primary school (age group 7 to under 11 years)**	1000-1600 families/5000-8000 persons	Minimum 3950 m ² site area with minimum site width of 55m	Local
Secondary school (age group 12 to under 17 years)	1800-2400 families/9000-12000 persons	Minimum 6950 m ² site area with minimum site width of 65m	Ward
Colleges/community colleges/vocational colleges	10,000 families/50000 persons	2000 m ² -7000m ² site area	Regional

Facilities	Threshold Population to Start the Facilities	Minimum Reference Standard	Level Served
Commercial			
Small store/s	50 families	4 stores per 200 families (20 m ² per store, max)	Plot/ local
Medicine store/dispensary/ convenience grocery store/ bakery/beauty parlor	200 families	175 m ² per 400 families minimum	Plot/ local
Super-market	2000 families/10,000 persons		Ward/ regional
Shopping center	4000 families/20,000 persons		Ward/ regional
Socio-Cultural			
Community welfare center	300 families	400 m ² per 300 families	Local
Places for worship (Mosques, temples, churches etc.)	400 families	175 m ² per 400 families	Local
Community Hall	1000 families	Plot size 1300 m ² minimum.	Local/ ward
Library	1000 families	175 m ² minimum	Ward
Healthcare			
Health center	400 families/2000 persons	175 m ² per 400 families	Ward
Small clinic	2000 families/10,000 persons	Minimum 2200 m ² plot per 10,000 persons	Ward
Services and Utilities			
Internal roads and walkways	Any	15 to 20 per cent of the site area	
Amenities (Garbage disposal, water pump, local electrical substation/generator etc.)	Any	5 per cent of the site area	Local

Facilities	Threshold Population to Start the Facilities	Minimum Reference Standard	Level Served
Office of local authority, community police etc.	400 families/ 2000 persons	175 m ² per 400 families	Ward
Public transport stoppage/ station***	As per planning guideline	At least 1 bus bay with passenger shed	
Sports and Recreational			
Park, water front	2000 families/10,000 persons	1 hectare minimum per 10,000 persons	Ward/regional
Play ground	1000 families/ 5,000 persons	400 m ² minimum (local level) per 5000 persons	Local/ward
Children and youth center	2400 families/12,000 persons	630 m ² minimum per 12000 persons	Local/ward
Gymnasium, Indoor games	1000 families/5000 persons	175 m ² minimum per 5000 persons	Local/ward
Swimming pool	6000 families/30,000 persons	420 m ² of water surface/ 30,000 persons	Ward
Sports Complex with indoor and outdoor facilities	10,000families/ 50,000 persons	0.6 hectare (ward level) per 50000 persons	Ward
<p>* All general facilities shall be accommodated within the plot or block or cluster area. For any housing having a population of 10 families or above, the total built area (excluding community open space) dedicated to such facility/ facilities (depending upon the population size) shall not be less than 1m² per person.</p> <p>** All such facilities must be a part of integrated planning prioritizing close proximity to the housing units they serve. The distance of such facilities from the serving units should not be more than 0.4 kilometers, All such connecting pathways, street etc. shall be away from major roads and shall have pedestrian priority.</p> <p>*** Public transport stoppages should be located nearer to health facilities, post-secondary educational institutions and other public buildings and should be supported by public parking facilities nearby.</p>			

B.3.4 Size of Plot

B.3.4.1 Minimum standard community housing

All minimum standard community housing shall follow the general guidelines of plot sizes mentioned in Appendix A.

B.3.4.2 Minimum standard transitional housing

All types of minimum standard transitional housing, except site and service type, shall be group housing (A3 or A4 occupancy) and shall abide by the plot size requirement of Appendix A. For Site and Service transitional housing, the authority may allow higher density for larger plot size with close proximity to public transport network provided that such decisions are in compliance with the planning guidelines for the area or locality.

Site and Service Scheme for Single Room Development : For site and service transitional housing development where a minimum standard house with single room, kitchen, bathing facilities and water closet are expected to develop, the minimum plot size may be reduced to 30 m² with a minimum frontage of 4.1 m. In areas other than metropolitan cities; with population less than 0.5 million, the minimum size of plot for such houses should be 40 m² with a plot frontage of minimum 4.8 m. In dense inner city areas of metropolitan cities with population more than 1.5 million, the Government may decide to have a minimum plot size of 25 m² with a minimum frontage of 4.1 m for such housing.

Site and Service Scheme for Two Room Development : For site and service transitional housing development where a minimum standard house with two rooms, kitchen, bathing facility and water closet are expected to develop, a minimum plot size of 40 m² shall be required. In areas other than metropolitan cities, having a population less than 0.5 million, the minimum size of the plot for such houses should be 60 m².

B.3.5 Internal Roads and Walkways

Pedestrian walkways when provided as means of access shall be at least 3 m wide. Such walkways shall not be longer than 60 m, nor serve more than 10 plots on each side of the path. Other internal roads shall be at least 6 m wide to allow emergency vehicles to enter. The paved portion of such roads, if used for pedestrian movement only, should be at least 2 m wide.

B.4 General Building Requirements

B.4.1 Plinth Coverage

The plinth area coverage of any plot of minimum standard housing shall not exceed 65 percent of the plot area. Plots with higher net density shall have lower plinth area and ground coverage.

Exception: For minimum standard transitional housing

The plinth area coverage of any plot of transitional housing shall not exceed 75 percent of the plot area. There shall be a setback of minimum 1.5 m on the rear side of a plot. There is no requirement for such set back on the sides and front of a plot if facing an internal road.

B.4.2 Height Limitation

The height limitation in such housing will vary according to typology of each development. However, maximum height for minimum standard housing for site and service scheme shall be 10 m. Minimum standard transitional housing of cluster type development and multistoried Row type development shall have a height limitation of maximum 20 m or 6 storied.

B.4.3 Plinth Level

The minimum height of the plinth shall be 300 mm from the surrounding ground level.

B.4.4 Habitable Room

B.4.4.1 All dimension stated in this Section do not include area or dimension required for partition or enclosure wall. Criteria for habitable room shall follow the basic guidelines of Part 3 Chapter 1.

B.4.4.2 Overcrowding

To avoid overcrowding in all habitable rooms in minimum standard housing including transitional housing, a minimum air volume of 9.5 m³ (9.5 cubic meters) per occupant shall be allotted. To calculate such volume no account shall be taken of any space with a height higher than 4.25 m or less than 2.15 m from the floor level of the room.

Exception: For transitional housing

- (a) In a flatted development, one roomed dwelling units shall have a multi-purpose room which may include an alcove or space for cooking (as specified in Sec B.4.5). The minimum area of the room shall be 12 m² with a minimum width of 2.5 m.
- (b) For dwelling units with two habitable rooms, the minimum size of at least one room shall be 9.5 m² with a minimum width of 2.5 m. Other habitable room in the dwelling unit shall have a minimum area of 5 m² with a minimum width of 2 m.
- (c) One-roomed dwelling with plan for future extension into a two-roomed house in a staged construction scheme shall satisfy the requirement of (a) and (b) above regarding room sizes. The first room to be built in this type of development shall have a minimum area of 9.5 m² with a minimum width of 2.5 m. The total area of the two rooms after future extension shall be a minimum of 15 m².
- (d) All habitable rooms shall have a minimum clear height of 2.75 m. For sloped roofs, the average height shall not be less than 2.75 m with a minimum of 2 m at the lowest side.

B.4.5 Kitchen

B.4.5.1 Criteria for kitchen shall follow the basic guidelines of Part 3 Chapter 1.

B.4.5.2 Exception: For minimum standard transitional housing

- (a) The size of the cooking alcove or cooking space provided in a multi-purpose room of a one-roomed house shall not be less than 2.25 m² with a minimum width of 1.2 m.
- (b) Separate kitchen provided in a two-roomed house shall have a minimum area of 3.25 m² with a minimum width of 1.6 m.
- (c) Minimum clear height of the kitchen or cooking space shall be 2.15 m.

B.4.6 Bathroom and Water Closet

B.4.6.1 Independent water closets shall have a minimum width of 0.9 m and a minimum length of 1.15 m. The water closet shall be fitted with a door.

B.4.6.2 Independent bathroom without water closet shall have a minimum width of 1 m and a minimum length of 1.4 m.

B.4.6.3 The minimum size of a combined bathroom and water closet shall be 1.8 m² with a minimum width of 1 m. The bathroom shall be fitted with a door.

B.4.6.4 The minimum clear height of bathrooms and water closets shall be 2.15 m.

B.4.7 Balcony and Corridor

B.4.7.1 The minimum width of individual balcony shall be 0.9 m. Corridors for use of more than one dwelling units shall have a minimum width of 1.2 m.

B.4.8 Stairs

B.4.8.1 Minimum Width: Criteria for minimum width of stairs shall follow basic guidelines of Chapter 1 Part 3.

B.4.8.2 Maximum Rise: Criteria for maximum riser shall follow the basic guidelines of Chapter 1 Part 3.

B.4.8.3 Minimum Tread Depth: Criteria for minimum tread depth shall follow the basic guidelines of Chapter 1 Part 3.

B.4.8.4 Minimum Head Room: Criteria for minimum clearance of head room shall follow the basic guidelines of Chapter 1 Part 3.

B.4.8.5 Landing: Criteria for minimum landing depth shall follow the basic guidelines of Chapter 1 Part 3.

B.4.9 Water Supply

One water tap or hand tube-well pump per dwelling unit should be provided, if feasible. Each unit of public water hydrants or community hand pumps, if provided in lieu of individual water supply, shall serve not more than 10 dwelling units and shall not be farther than 15 m from any dwelling unit served.

B.4.10 Lighting and Ventilation

Every room, bathroom and kitchen shall have windows in an external wall opening on a courtyard, a balcony not wider than 2.5 m, or the exterior. The aggregate area of openings in the exterior wall of a habitable room or kitchen shall not be less than 12 percent of the floor area and that for a non-habitable room such as bath room, water closet or stair shall be at least 8 percent of the floor area.

**PART III
Appendix C**

Special Requirements of Cluster Planning for Housing

C.1 General

These guidelines cover the planning and general building requirements of different housing developments in cluster typologies as referred in Appendix B. These requirements are applicable to all housing projects of this type taken up by public, private or co-operative agencies.

All cluster housing typologies shall fulfill the criteria regarding minimum area and width requirement of each habitable and non-habitable room as specified by this Code. The construction classification for Cluster Housing shall be of protected type.

C.2 Cluster Typology

C.2.1 Cluster Type Development

Cluster type development (Figure 3.C.1), as a housing form, is suitable for accommodating low to moderate density of population. However with smaller plot size, it can also attain high density situation as may happen for Transitional Housing.

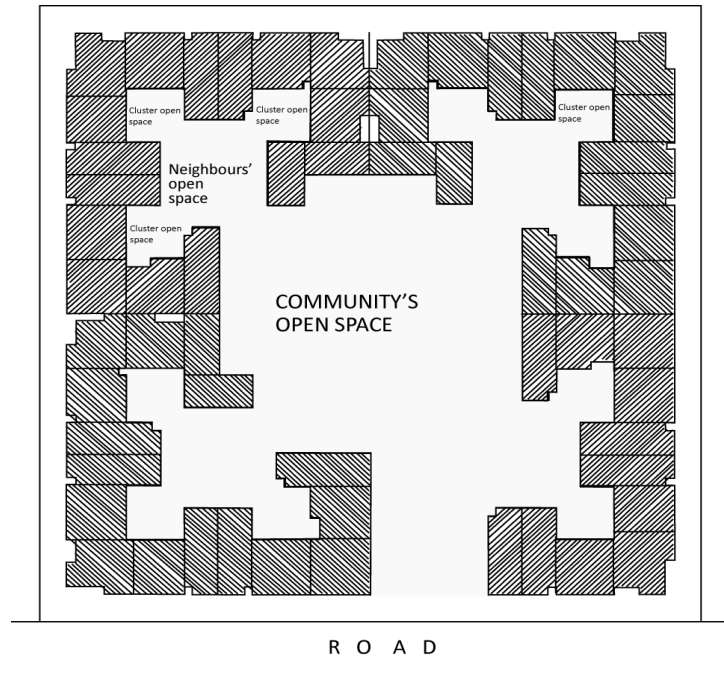


Figure 3.C.1 Cluster type Housing

C.2.2 Examples of Cluster Typologies

- (a) Back-to-Back Cluster—Clusters when joined back to back and/or on sides (Figure 3.C.2).
- (b) Closed Clusters—Clusters with only one common entry into cluster open space (Figure 3.C.3).
- (c) ‘Cul-de-sac’ Cluster—Plots/dwelling units when located along a pedestrianized or vehicular ‘cul-de-sac’ road (Figure 3.C.4).

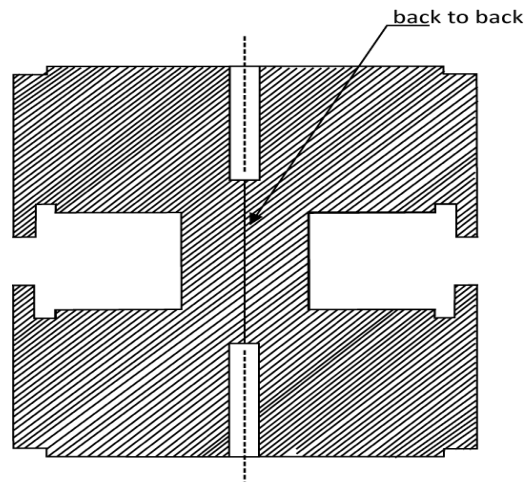


Figure 3.C.2 Back to back cluster

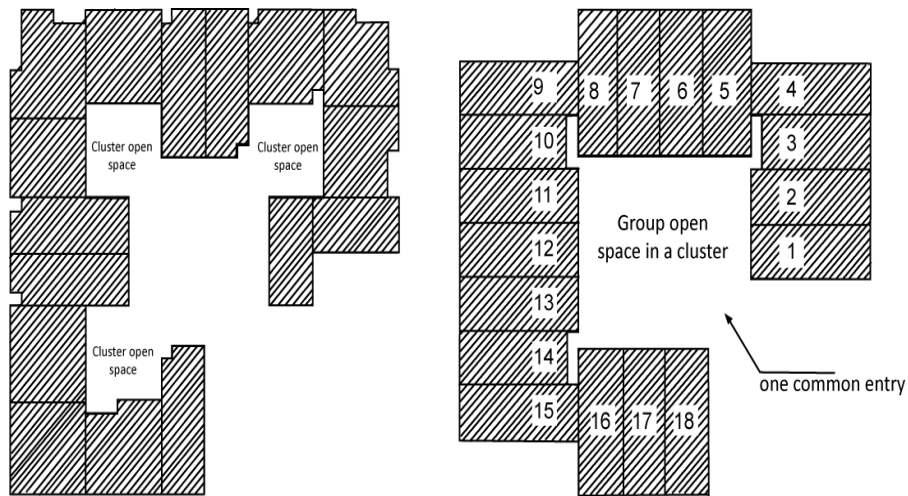


Figure 3.C.3 Closed cluster

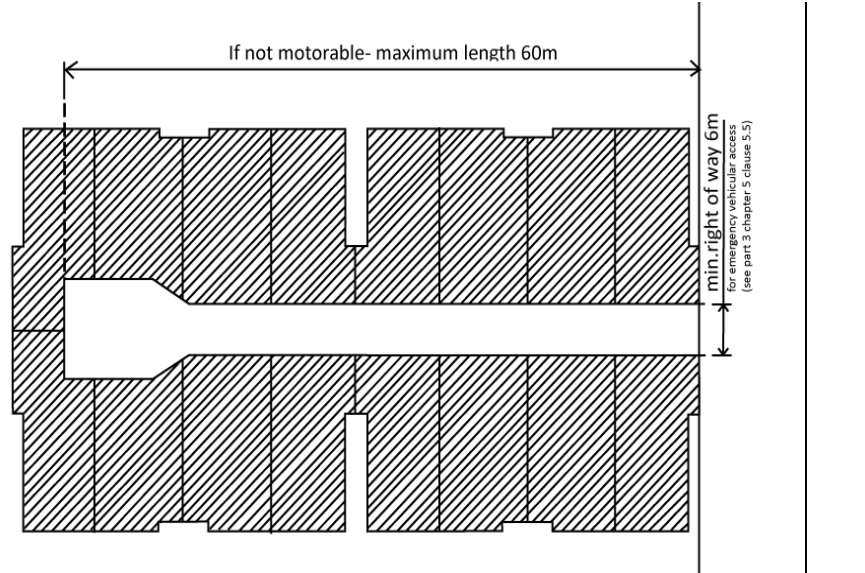


Figure 3.C.4 Cul-de-sac cluster

C.2.3 Plot Size

In an integrated cluster planning, the minimum plot size shall comply with the guidelines set in Appendix B (including transitional housing).

C.2.4 Community Facilities

All such housing shall be provided with the requirement of neighbourhood and community facilities required for the population. In such cases, the authority may allow a FAR of 2.00 with 100 percent ground coverage provided that the basic natural lighting and ventilation criteria is met through the two exterior sides, both having exposure to the adjacent neighbourhood spaces.

C.2.5 Group Housing

Group housing may be permitted in the form of cluster housing. However, dwelling units with plinth areas up to 20 m² should have scope for adding a habitable room. Group housing in a cluster should not be more than 15 m in height.

C.2.6 Size of Cluster

In single to two-storeyed structures not more than 20 houses should be grouped in a cluster. Clusters with more dwelling units may create problem relating to identity, encroachment and maintenance.

C.2.7 Size of Cluster Open Space

Minimum dimensions of width of open spaces shall be not less than 6 m or 3/4th of the height of buildings along the cluster open space, whichever is higher. The area of such cluster court shall not be less than 36 m². Group housing around a cluster open space should not be more than 15 m in height.

C.2.8 Setbacks

In any cluster type development at least two sides of each individual dwelling shall have exterior walls and opening. No setback is required in other two sides of such developments. However for compliance of natural lighting and ventilation with this code, light well and ventilation well may be used within a cluster plot.

C.2.9 Right to Build in Sky

Pedestrian paths and vehicular access roads to clusters separating two adjacent clusters may be bridged to provide additional dwelling units. While bridging the pedestrian path way minimum clearance should be one storey height; length of such bridging should be not more than two dwelling units. While bridging the vehicular access roads minimum clearance from ground level shall be 6 m with a vertical clearance of 5 m.

C.2.10 Vehicular Access

A right of way of at least 6 m width with a vertical clearance of 5 m shall be provided up to the entrance to the cluster to facilitate emergency vehicle movement up to cluster.

C.2.11 Pedestrian Paths

Minimum width of pedestrian paths shall be 3 m.

C.2.12 Width of Access between Two Clusters

Built area of dwelling unit within cluster shall have no setbacks from the path or road, space. Hence, the height of the building along the pathway or roads shall be not less than 60 percent of the height of the adjacent building subject to minimum of 3 m in case of pathway and 6 m in case of vehicular access.

C.2.13 Density

Transitional housing shall result in higher densities with low rise structures.

For a minimum standard housing with one habitable room, one kitchen and one two-fixture toilet and the required enclosure walls as per provision of this Code, a minimum dwelling unit of 23.81 m² is required. However for transitional housing, the size of dwelling units may be reduced up to 18.5 m² to increase density. In all such transitional housing a maximum allowable density shall follow the density guidelines of Appendix B.

C.2.14 Group Toilet for Transitional Housing

Transitional housing may have group toilets at the rate of one water closet, one bath and a washing place in three separate chambers per three families. These shall not be community toilets, as keys to these toilets shall be only with these three families, making them solely responsible for the maintenance and upkeep of these toilets.

C.3 Other Requirements**C.3.1 Requirements of Building Design**

With the exception of clauses mentioned above, requirements of building will be governed by the provision of this Code and good practice. Requirements of fire safety, structural design, building services and plumbing services shall be as specified in this Code.

PART III
Appendix D
Universal Accessibility

D.1 Scope

The aim of this Appendix is to set out the fundamental design and construction requirements and guidelines for different occupancy types, accessible to persons with permanent or temporary disabilities. The requirements and guidelines should be applicable for all buildings and facilities as shown in Table 3.D.1 for emergency evacuation provisions of Part 4 shall be applicable.

D.2 Terminologies

D.2.1 Definitions

For the purpose of this Part of the Code, the definitions/terminologies below shall be applicable:

ACCESSIBLE/ ADAPTABLE WASHROOM	Refers to a compartment with a water closet, wash basin, grab bars and other essential washroom accessories and with clear floor spaces at fixtures as per provision of this Code which a wheel chair user or any other person with disability can avail with ease and safety.
ACCESSIBLE/ ADAPTABLE WATER CLOSET COMPARTMENT	Refers to a compartment with adequate maneuvering space as per provision of this Code having a single water closet with grab bars installed to assist persons with disabilities.
ACCESSIBILITY	See Part 3 Chapter 1 definition.
ACCESSIBLE RAMP	See Part 3 Chapter 1 definition.
ACCESSIBILITY ROUTE	See Part 3 Chapter 1 definition.
ADAPTABLE	See Part 3 Chapter 1 definition.
AMBULANT DISABLED	Refers to any person who, with the help of prostheses (artificial limbs)/ orthotic/ crutches/canes/ sticks or any other walking aid, is able to walk on level plain or suitably graded steps with handrails complying the provision of this Code.

CIRCULATION PATH	See ‘accessibility route’
CURB	Refers to a side barrier between a trafficable surface and adjacent area through level change.
CURB RAMP	Refers to a short ramp cutting through a curb or built on it to negotiate accessibility between levels, which may have a different gradient as per provisions of this Code than a conventional accessible ramp.
GRAB BAR	Refers to a bar of certain specification and height as per provision of this Code which is used for assisting to stabilize a person with disability for performing a particular function.
HANDRAIL AND GUARDS	See Part 4 Chapter 3.
OPERABLE PART	Refers to part or component of any equipment, appliance or fixture which is necessary to operate that equipment, appliance or fixture (for example, handle, lever, push-button etc.).
PERSONS WITH DISABILITIES	Refer to persons whose mobility and capacity to use a building or part there of or a facility are affected due to one or more physical and/or sensory disabilities or impairments. For the purpose of this Code, they will be categorized as following: <ul style="list-style-type: none">(a) Wheelchair-bound(b) Ambulant disabled(c) Hearing impaired and(d) Visually impaired.
SYMBOL	Refers to the international symbol of access for persons with disabilities also known as International wheel-chair symbol.
WHEELCHAIR USER	Refers to a person with disability who is depended on a wheelchair for mobility.

D.3 Provisions For Accessibility

D.3.1 Barrier-Free Accessibility

The following building occupancies shall require barrier free accessibility for persons with disability in the areas or facilities as specified in Table 3.D.1.

Table 3.D.1: Requirements of Accessibility for Different Occupancies

Occupancy Type		Accessible Areas
Residential buildings	A3*, A5, MIXED	From public footpath and parking areas to the lift lobby, lift, from lift lobby to all housing units, at least one toilet per housing unit and all communal facilities
Hostels and dormitories	A4, MIXED	All public areas intended for access by staff, students or visitors and at least one room per every hundred rooms or portion thereof including access to public footpath and parking.
Schools, colleges, universities or other educational buildings	B1-B3, MIXED	All areas intended for access by staff, students or public use including access to public footpath and parking.
Hospitals, clinics, homes for the aged and Institutions for the physically challenged	D1, D2, C3	All areas intended for access by staff, patients, inmates or public use.
Office buildings	E1, E3, MIXED	All areas intended for access by employees or public including parking and at least one accessible toilet facility in each floor
Small shops and markets, Kitchen markets	F1, F3, MIXED	From parking and/or public footpath to sales counter service
Large shops and markets	F2, MIXED	All areas intended for access by employees or public including access to public footpath and parking.
Factories, workshops, industrial buildings and administration buildings in depots	G1, G2	All areas intended for access by employees or public use.

Occupancy Type		Accessible Areas
Religious buildings, crematoria	I1-I4, MIXED	All areas intended for access by worshippers or public including access to public footpath and parking.
Restaurants, food-courts, fast food outlets and other public eating outlets	I1-I4, MIXED	All areas intended for access by employees or public including access to public footpath and parking.
Cinemas, theatres, stadia or other places of assembly with permanent seating	I1-15, MIXED	All areas intended for access by performers and areas prescribed by this Code for spectators or public use (Sections D.3.2.3 and D.3.2.5) including access to public footpath and parking.
Sports complexes, public gymnasiums and public swimming pools	I5	All areas intended for public access with at least one accessible shower compartment and one water closet compartment.
Stations, airports, river-ports, bus terminals, interchanges and other passenger transport terminal	MIXED	All areas intended for access by employees or public use including areas prescribed in Sec D.3.2.7.
Parking garage, private garage, repair garage and showrooms	K1-K3	Prescribed areas in accordance to Sections D.24 and D.25.

Note:*Excluding apartments without lift

D.3.2 Minimum Accessible Provisions

D.3.2.1 Mess, dormitories and hostels

In residential occupancies such as mess, dormitories and hostels, at least one room in every 100 rooms or part thereof shall be accessible.

D.3.2.2 Hotels and lodging houses

In room based residential occupancies e.g. Hotels, lodging houses etc. at least one in every 200 guest-rooms or a portion thereof shall be made accessible.

D.3.2.3 Banks, ticketing offices and counter services

Public facilities with counter services, such as, banks, information desk, ticketing offices etc. at least one service counter shall be designated in accordance to the requirements of Sec D.13.

D.3.2.4 Large shops and markets, foyers and public concourses

In large shops and markets such as large departmental stores, shopping mall etc. seats shall be provided for persons with disabilities who are unable to stand or walk for long periods. There shall be at least one accessible toilet per floor connected to the accessible route within such facilities. Seats and free spaces for wheelchair users shall also be required in foyers and concourses of public buildings.

D.3.2.5 Movie theatres, theatres, stadiums or other places of fixed-seat assemblies

Assemblies with permanent fixed seats such as movie-theatres, theatres, stadium, indoor stadium etc. shall have one wheelchair space per every 150 seats or a portion thereof. Such spaces should be located at a level that is easy to access for the wheelchair users. Seat arrangements shall facilitate wheelchair users to sit with their able bodied companion together. All such assemblies shall facilitate accessible counter facilities and toilets for persons with disability within the accessible route.

D.3.2.6 Eating outlets

Eating outlets with fixed seats such as fast food shops, food courts etc. shall have one accessible wheelchair seating per 10 seats or portion thereof. Seat arrangements shall facilitate wheelchair users to sit with their able bodied companion together.

D.3.2.7 Public transport terminals, bus stops, railway stations

All public transport terminals including bus stops and railway stations shall be accessible to persons with disabilities. The waiting areas of all such facilities shall be provided with seats for such persons who are unable to stand for long periods. Aisles for movement in such spaces shall be not less than 1200 mm.

Necessary signs and symbols shall denote the accessible routes and facilities within or outside all such buildings or facilities where 'Tactile indicators' shall guide the passengers from public footpath and accessible parking areas to specific ticket counter, waiting areas, toilets and other service facilities, arrival and departure platforms and to exits.

Doors of all public transports shall be accessible universally. Minimum clearance of all such doors shall be 900 mm. All such public transport should have at least two designated seats per coach near the door reserved for people with disability. A stall for a wheel chair per coach near the door should also be designated with provision for wheel stop blocks, safety bar with safety straps and adequate signage.

In all public railway carriages with toilet or dining facilities, the aisle width within the carriage should be at least 1200 mm.

It is preferable that there should be no level change between the platform level and the deck of the transport in use. However, where such level differences occur, ramp or lift facilities should be available to ensure universal accessibility.

D.4 Minimum Space Allowances

D.4.1 Minimum Space Requirement for Wheel Chair Users

Depending upon the nearest obstruction and the direction of movement a wheelchair user shall be considered for two approaches and shall require a minimum of 900 mm x 1200 mm unobstructed floor area as shown in Figure 3.D.1.

To facilitate both parallel and forward approaches for wheelchair users, a minimum clear floor space of 1200 mm x 1200 mm, as shown in Figure 3.D.2.

The minimum clear turning space for a manually operated wheel chair shall be 1500 mm x 1500 mm. For a powered wheel chair the requirement of turning space shall be 2250 mm x 2250 mm.

Where two wheelchairs are required to cross side by side, a minimum accessible clear width of 1800 mm shall be provided. The minimum width of an accessible route shall be 1200 mm, as shown in Figure 3.D.3.

D.4.2 Projection, Protrusion and Obstacles in an Accessible Route

All along the pedestrian areas accessible to persons with disabilities (e.g. walkways, halls, corridors, passageways etc.) any kind of obstacle, projection or protrusion shall be avoided. For all such areas an obstacle or projection or protrusion of 100 mm or less from side walls within the circulation space may be exempted. When such protrusion is more than 100 mm, the bottom edge of the protruding object shall not be more than 580 mm above the floor level, as illustrated in Figure 3.D.4. Such projections or protrusions shall not reduce the clear width required for an accessible route or maneuvering space; to provide such protruding objects, space shall be provided to accommodate those objects in addition to the required clear width.

The minimum clearance for headroom in all accessible areas such as walkways, halls, corridors, passageways or aisles shall be 2000 mm. Any free standing post or object on or beside an accessible route shall follow the guidelines of Figure 3.D.5.

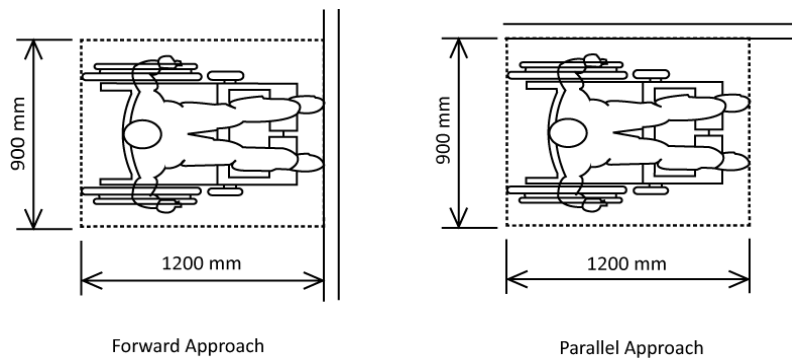


Figure 3.D.1 Minimum clear floor space

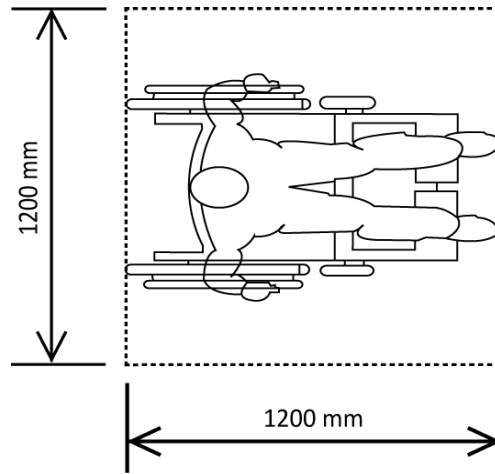


Figure 3.D.2 Minimum clear floor space (both frontal parallel approach)

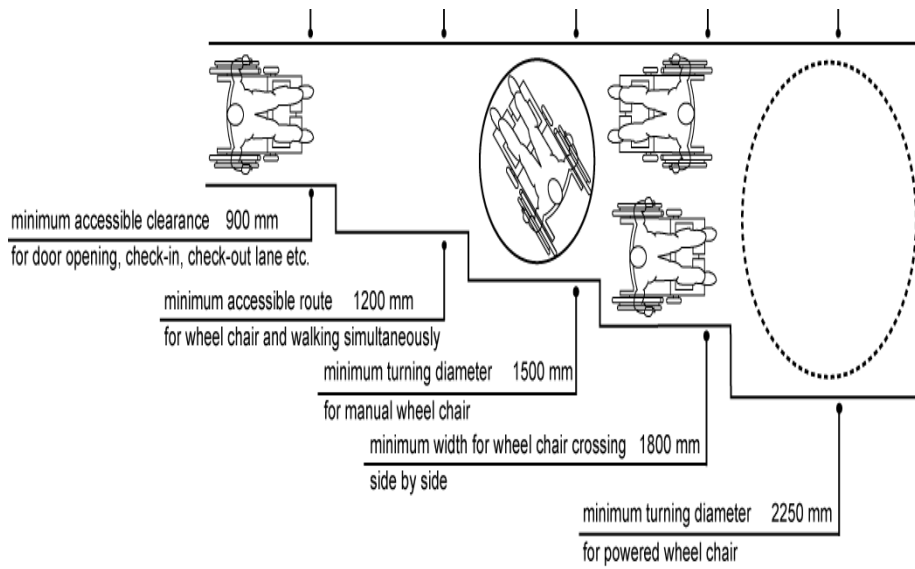


Figure 3.D.3 Minimum width of accessible routes

D.5 Surface Quality of Floor Space

D.5.1 General

All pavement or floor surfaces required to be accessible shall be firm, even, slip-resistant and stable. Any change of level of such surfaces shall be negotiated in compliance with Sec D.5.2 or through accessible lifts as per provision of this Code. To assist persons with visual impairment, such floors or their skirting shall have finishes of contrasting color with adjacent walls.

D.5.2 Change in Level

Any change of level in an accessible route shall generally have gradient of at least 1 vertical to 12 horizontal towards the direction of travel. All such slopes shall have special markings with contrasting colors at the top and the bottom of the ramp or on the ramp slope as shown in Figure 3.D.6.

However, for change of vertical level up to 150 mm within any accessible route a steeper slope may be allowed in accordance to Table 3.D.2.

Since for some ambulant disabled persons, steps are convenient and safer to use than ramps, accessibility provision by both ramps and steps should be given.

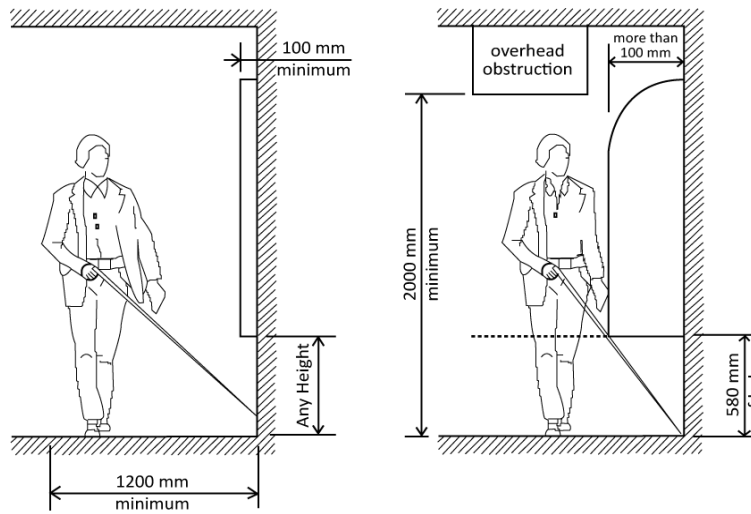


Figure 3.D.4 Limit of protruding objects

D.5.3 Gratings

For safety of people with disabilities, the elevation of gratings located on an accessible route shall be at the same level and aligned perpendicular to the direction of travel. The gap of such gratings shall not be more than 12 mm at any direction.

D.5.4 Surface Texture

In an accessible route, apart from the general requirement of Sec D.5.1, floor surfaces with tactile indicators shall be required. In such cases dot type surface texture on floor shall indicate a warning, while line type surface texture on floor shall indicate the intended path of travel.

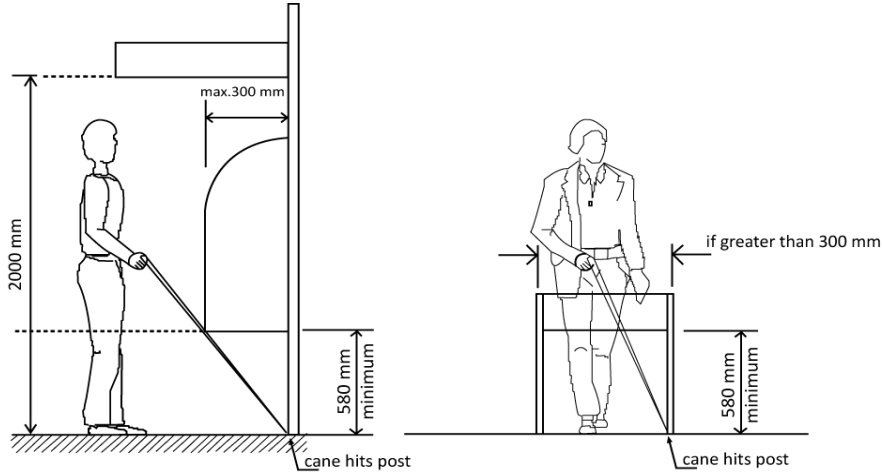


Figure 3.D.5 Limit for free-standing objects mounted on post

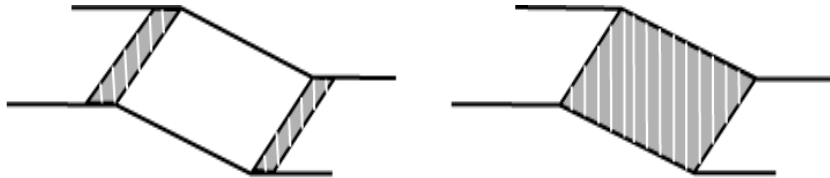


Figure 3.D.6 Markings on an internal ramp

Table 3.D.2: Gradient for Changes in Levels

Maximum Vertical Change of Level (mm)	Maximum Allowable Length (mm)	Maximum Slope Ratio
0 to 75	600	1 vertical to 8 horizontal
more than 75 to 150	1500	1 vertical to 10 horizontal
More than 150	9000	1 vertical to 12 horizontal

D.6 Approaches

D.6.1 Public Access Ways

The minimum unobstructed width of an accessible public access way such as footpath, corridor, foot over bridge, under pass etc. shall be 1200 mm. All such ways shall have a 1500 mm x 1500 mm space per every 30 m of length to facilitate crossing or turning of users. However for pathways with width of 1500 mm or more no additional width shall be required. The minimum access width shall not be encroached by obstruction or protrusion of any kind and shall comply with provisions of Sec D.4.2.

D.6.2 Vehicular Approach to Building

To facilitate persons with disability approaching by vehicles the driveway, walkway and accessible parking surfaces within a site shall either be merged to a common level or be connected by ramp (Sec D.5.2 and Table 3.D.2).

For occupancies mentioned in Sec D.3.2, at least one accessible route leading to an accessible entrance of the building shall be provided from the descending and boarding point of vehicle parking lots for persons with disabilities.

D.6.3 Access to Building

All accessible buildings or facilities as specified in Sec D.3 shall have at least one accessible entrance door, located preferably with the main entrance and connected to an accessible route which shall be minimum 1200 mm wide. All accessible entrance doors shall comply with the provisions of Sec D.8.

D.6.3.1 Directional signs

To direct persons with disabilities to the accessible entrance/directional signs bearing the symbol shall be displayed at all other non-accessible entrances and accessible parking areas.

D.7 Accessible Routes, Corridors or Paths

D.7.1 Length Width and Height

Any accessible route should not be more than 30 m of length at a stretch. Where such routes exceed this limit, provisions of seating preferably with shading shall be required to reduce strain of persons with disability. The minimum width of all accessible routes shall comply with the provisions of Sections D.4 and D.6.1. Where one way accessible check-in or check-out lanes are provided, the minimum width shall be 900 mm. The minimum height or headroom clearance for any accessible route shall be 2000 mm all along its path of travel.

D.7.2 Surface Finishes

All surfaces, edges, ends and corners of surrounding building and finish materials along an accessible route shall be free from sharp edges and shall comply with provisions of Sec D.5.

D.7.3 Obstruction or Protrusion on Accessible Route

An accessible route shall be free from any kind of obstruction or protrusion. The minimum circulation space required for persons with disability in such route shall not be impeded or obstructed by projection or protrusion from side walls, overhead planes or from floor below.

If incase vertical obstacles such as posts, bollards etc. are inevitable on or beside an accessible route there shall be at least 900 mm clearance between them to allow through circulation. Overhead obstacles such as drop beam, signboards, canopies etc. shall have a minimum clearance of 2000 mm from the floor level of the accessible route. All possible obstacles shall have color contrast with their background to ensure clear visibility.

Protrusion from side walls on or beside an accessible route shall follow the guidelines of Sections D.4.1 and D.4.2. Projections or protrusions shall not reduce the clear width requirement for an accessible route; when such protruding objects shall be there, space shall be provided to accommodate those objects in addition to the required clear width.

D.7.4 Warning for Overhead Hazard

The minimum clear headroom in all accessible areas shall comply with Sec D.4. Whenever the headroom of an area adjoining an accessible route is less than 2000 mm, a detectable guardrail having its detectable edge at or below 580 mm from the floor level shall be provided as shown in Figure 3.D.7 to warn persons with visual impairment.

D.7.5 Physical Cue and Tactile Guidance

All accessible routes shall have provisions for physical cues and tactile guidance for persons with disability as per provisions of Sections D.5.4 and D.29.

D.8 Accessible Doors

D.8.1 General

An accessible doorway shall ensure the access of all people with specific provisions for unassisted wheelchair users safely and without inconvenience. For occupancies mentioned in Sec D.3.1, if revolving doors or turnstiles are required an ancillary swing door with a clear opening of minimum 900 mm shall be required to ensure accessibility.

The door threshold should preferably be at the same level with the floor. However if absolutely necessary, the allowed level change shall be maximum 20 mm from the floor level and shall be sloped to allow wheelchair access. All accessible bathroom and toilet doors should swing outwards to facilitate external emergency assistance. Accessible door shall have color contrast with its adjacent walls.

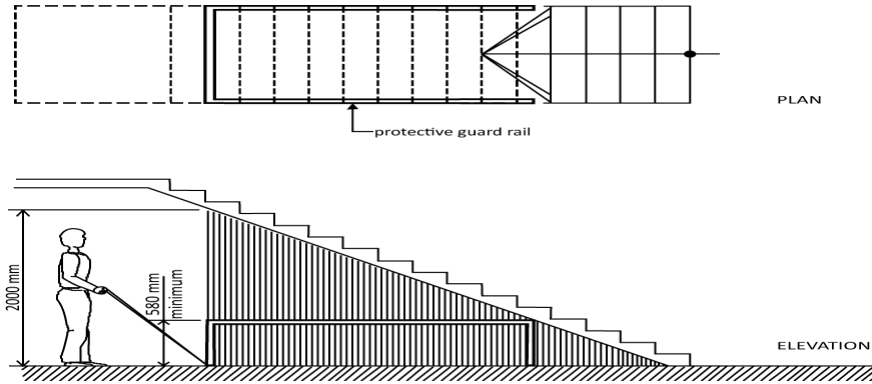


Figure 3.D.7 Protection from overhead hazard

D.8.2 Width of Accessible Door

A single leaf of any accessible doorway shall be 900 mm minimum measured between the face of the door leaf open at 90° and the face of the opposite jamb as illustrated in Figure 3.D.8. Where doorways have double-leaf at least one operable leaf shall allow 900 mm clearance to ensure accessibility.

D.8.3 Unobstructed Spaces for Operating Doors

All accessible swing doors shall have unobstructed spaces for wheelchair users on both side of the door leaf. In such cases the side, in which the door leaf swings open, shall be known as pull side while the opposite as push side. The requirement of unobstructed spaces in both the sides shall be in compliance with Figure 3.D.9.

Where two-way swing doors are used in an accessible route, both side shall be considered as pull sides and a vision panel complying with provisions of Sec D.8.5 shall be provided.

D.8.4 Door Operating Hardware

If not automatic, all accessories required for operating an accessible door such as door handles, fasteners, locks etc. shall be manually operable by one hand with ease. The height of all such accessories shall be within the range of 900 mm to 1100 mm from the floor level. Door handles are recommended over door knobs as knobs may be harder to operate for persons with grip difficulties, Figure 3.D.10.

D.8.5 Vision Panels

For the safety of ambulant disables or wheelchair users, all two-way swing doors across any accessible route shall have transparent vision panels as shown in Figure 3.D.11; where the bottom edge of such panels shall not be higher than 800 mm while the top edge of the panel shall not be less than 1500 mm, both measured from the floor level. The width of the viewing panel shall be not less than 150 mm. Such panels shall always be located at the opposite end of the hinged end on a door leaf.

D.8.6 Turnstiles

Whenever a turnstile is placed on an accessible route, an accessible gate with a clear width of at least 900 mm should be provided beside a turnstile, Figure 3.D.12.

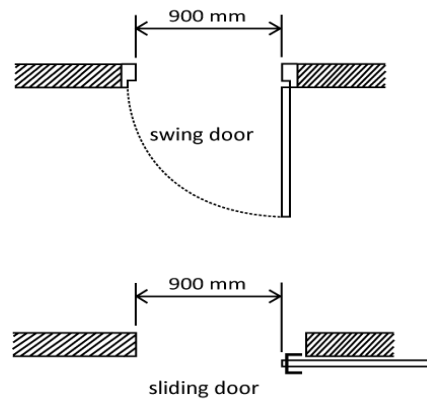


Figure 3.D.8 Clear width of accessible door

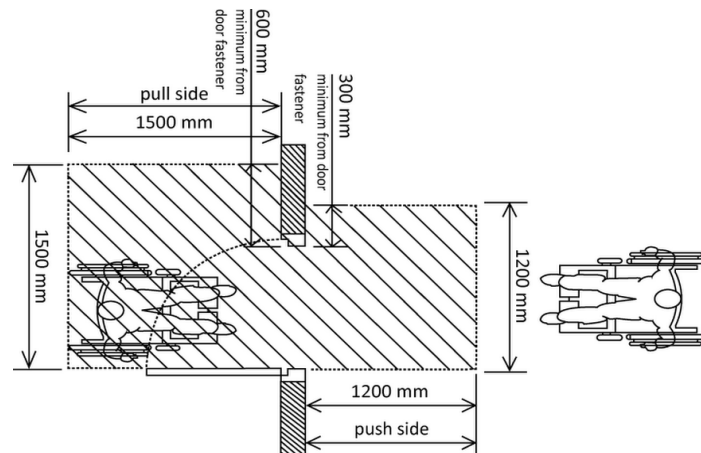


Figure 3.D.9 Minimum unobstructed space at doorway

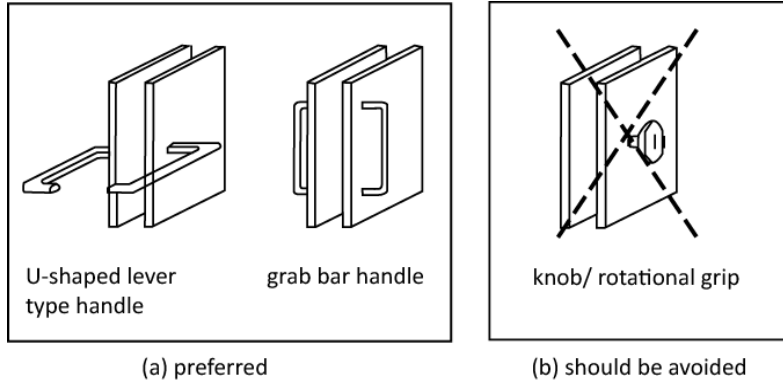


Figure 3.D.10 Preference of door handles

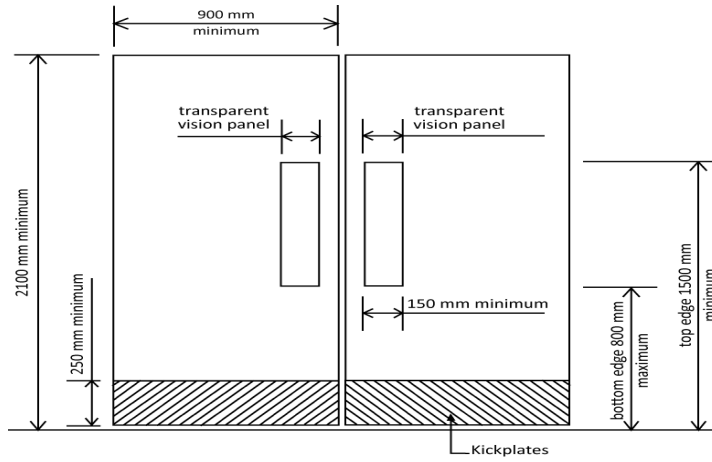


Figure 3.D.11 Dimensions and location of vision panel

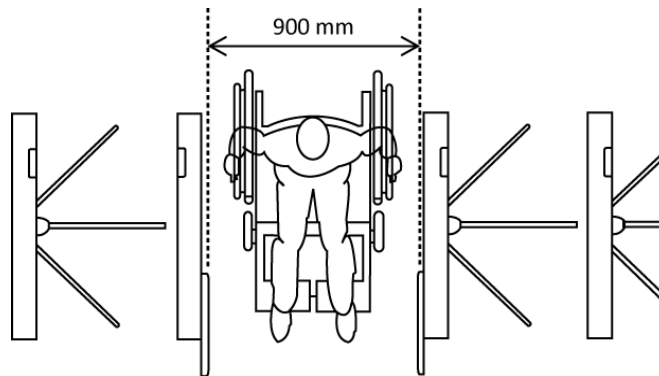


Figure 3.D.12 Access provision for turnstiles

D.9 Handrails and Grab Bars

D.9.1 General

Handrails and grab bars are very important safety features for any accessible facility. Therefore all such rails and bars shall be of accurate size and shape, slip-resistant, free of sharp or abrasive finishes and shall firmly hold with the supporting walls or floors or other form of supports. All such handrails shall have continuous gripping surfaces at a constant height throughout their length so that persons with disability do not lose balance due to loss of grip. There shall not be any sharp edges or corners in a handrail and a grab bar that may pose risk of injury. Handrail and grab bars should have color contrast with the background. Such handrails and grab bars shall not encroach on the minimum clear space for circulation.

D.9.2 Specific Requirements for Handrails and Grab Bars

All handrails in any accessible facility shall have a circular section of 35 mm to 50 mm external diameter or an equivalent gripping surface of any other section. The clearance between such hand rails and its adjacent wall shall be between 40 mm to 60 mm as shown in Figure 3.D.13.

Any recess containing a handrail shall have at least 450 mm clearance above the top of the rail as shown in Figure 3.D.13. Height of such handrails shall be within a range of 850 mm to 950 mm measured from the floor or in case of a stair from the nosing.

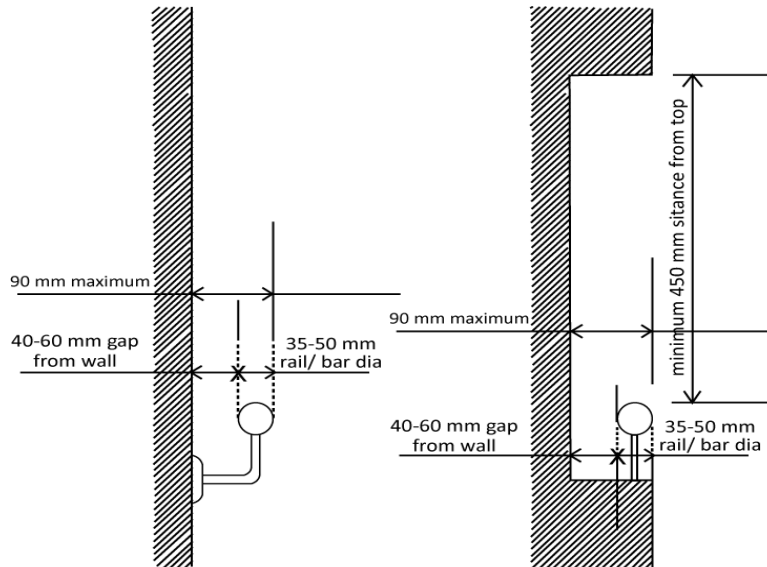


Figure 3.D.13 Handrails

D.9.3 Structural Strength

All hand rails and grab bars in an accessible facility shall be designed and built to resist a force of at least 1.3 kN applied vertically or horizontally.

D.10 Curb Ramps

D.10.1 General

Curb ramps in an accessible route should be kept within the pedestrian part of the circulation route and should not protrude within the vehicular area. If such protrusion is unavoidable, the curb ramps should be constructed with flared sides with gradient specified in Sec D.10.2. Such ramps do not require handrails as long as the level change is not greater than 150 mm.

D.10.2 Gradient, Width and Surface of Curb ramp

The gradient of a curb ramp shall follow the provisions of Table 3.D.2. The width of a curb ramp shall not be less than 900 mm. Where the vertical change of level is greater than 150 mm or the horizontal run is more than 1500 mm, it shall constitute an accessible ramp and shall conform to the requirements of Sec D.11. All surfaces of curb ramps shall be slip-resistant and shall have a detectable warning surface of contrasting color and texture complying with provisions of Sec D.29 for visually impaired persons. Curb ramps with flared sides shall not be steeper than 1:10 and shall follow the specifications shown in Figure 3.D.14.

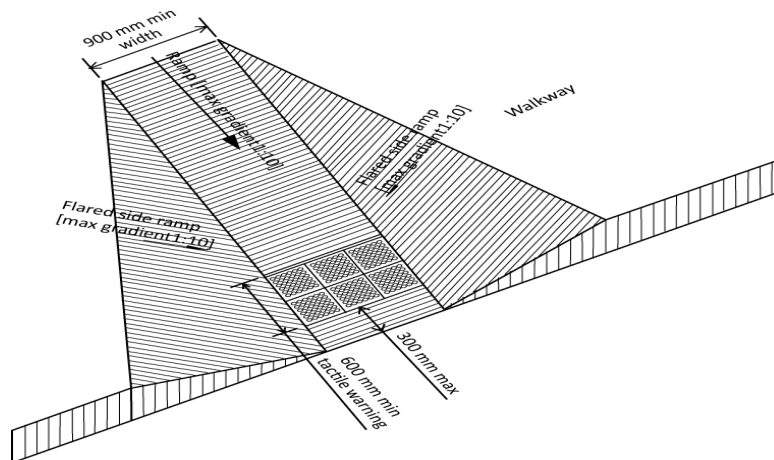


Figure 3.D.14 Curb ramp with flared sides

D.10.3 Location of Curb Ramps

All curb ramps should be built within the pedestrian zone and should not protrude to parking or any other vehicular area. However, in locations such as street crossing, road islands, road dividers and so on, curb ramps shall strictly be located within the pedestrian areas and shall follow the guidelines of Figure 3.D.15 and 3.D.16.

D.11 Accessible Ramps

Accessible ramps shall be used to provide connectivity between levels having height difference of more than 150 mm within a facility which are not served by accessible lift facilities. All such ramps shall comply with the provisions of Sections D.4 and D.5.

D.11.1 Gradient, Width and Surface of Accessible Ramp

The gradient of an accessible ramp shall follow the provisions of Table 3.D.2. The width of an accessible ramp shall not be less than 1200 mm. All surfaces of curb ramps shall be slip-resistant and shall have a detectable warning surface of contrasting color and texture complying with provisions of Sec D.29 for visually impaired persons. Where the horizontal run of an accessible ramp exceeds 9.0 m in length, there shall be a landing of at least 1500 mm length with tactile warning surface as shown in Figures 3.D.17 and 3.D.18. All such ramps shall have hand rails on both sides complying with provisions of Sec D.9.

D.12 Accessible Stairs

D.12.1 General

Stairs cannot provide accessibility for all persons with disability. Therefore stairs can only be an optional requirement for the ambulant disabled along with lifts or ramps. Any such stair or staircase should comply with the requirements of Sections D.12.2 to D.12.4. All handrail of accessible ramp shall have extensions either to floor or to wall as shown in Figure 3.D.19. For safety reason stairs with open risers or risers with projecting nosing

as shown in Figure 3.D.20 shall not be considered as accessible stair for ambulant disabled.

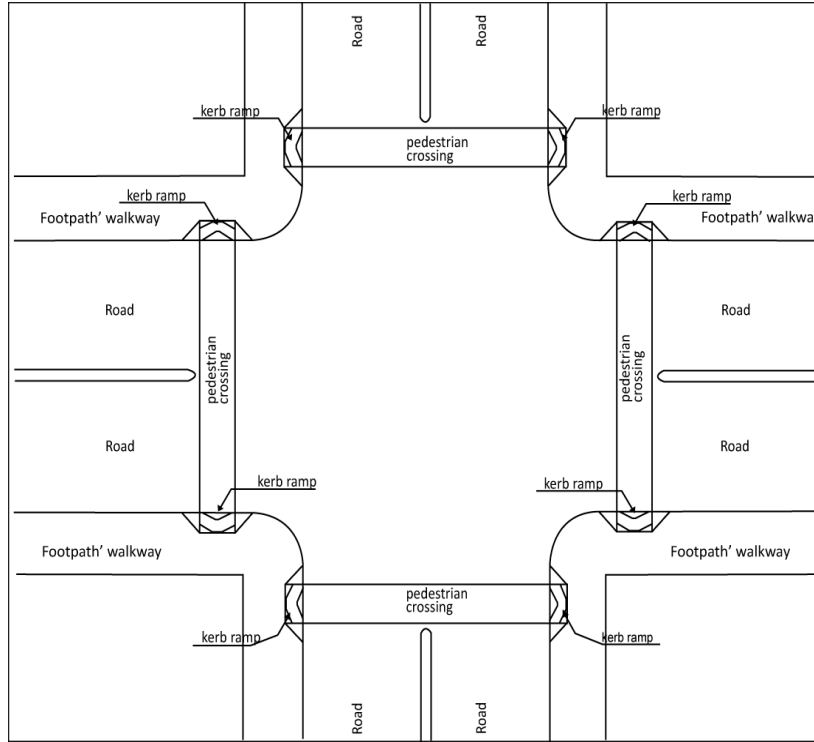


Figure 3.D.15 Location of curb ramp at street crossing

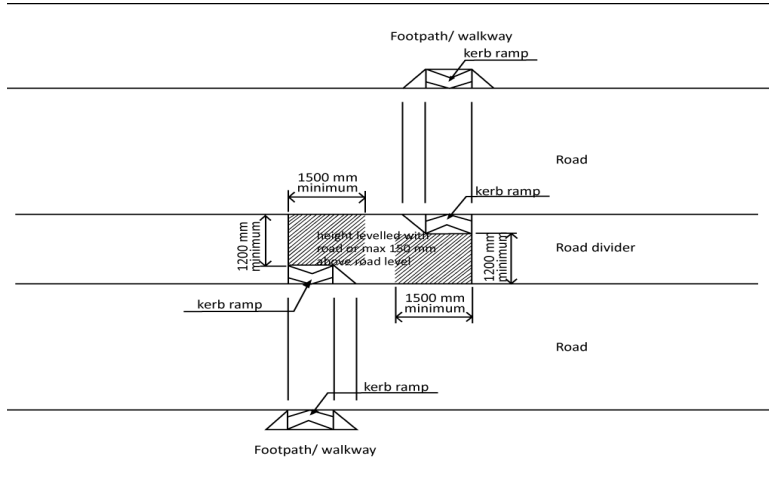


Figure 3.D.16 Location at road dividers

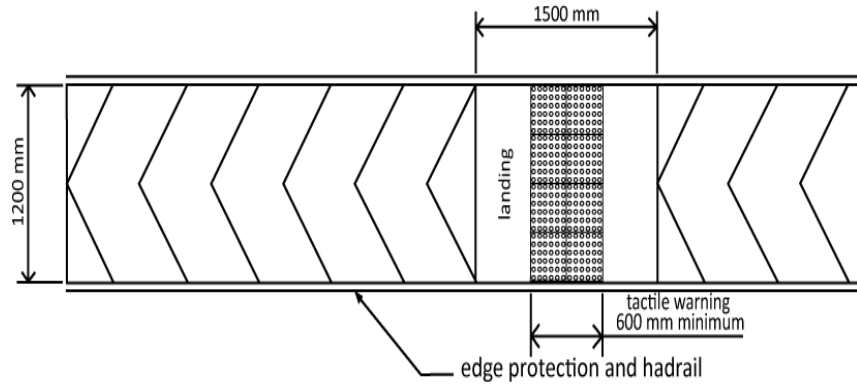


Figure 3.D.17 Plan of straight ramp and landing

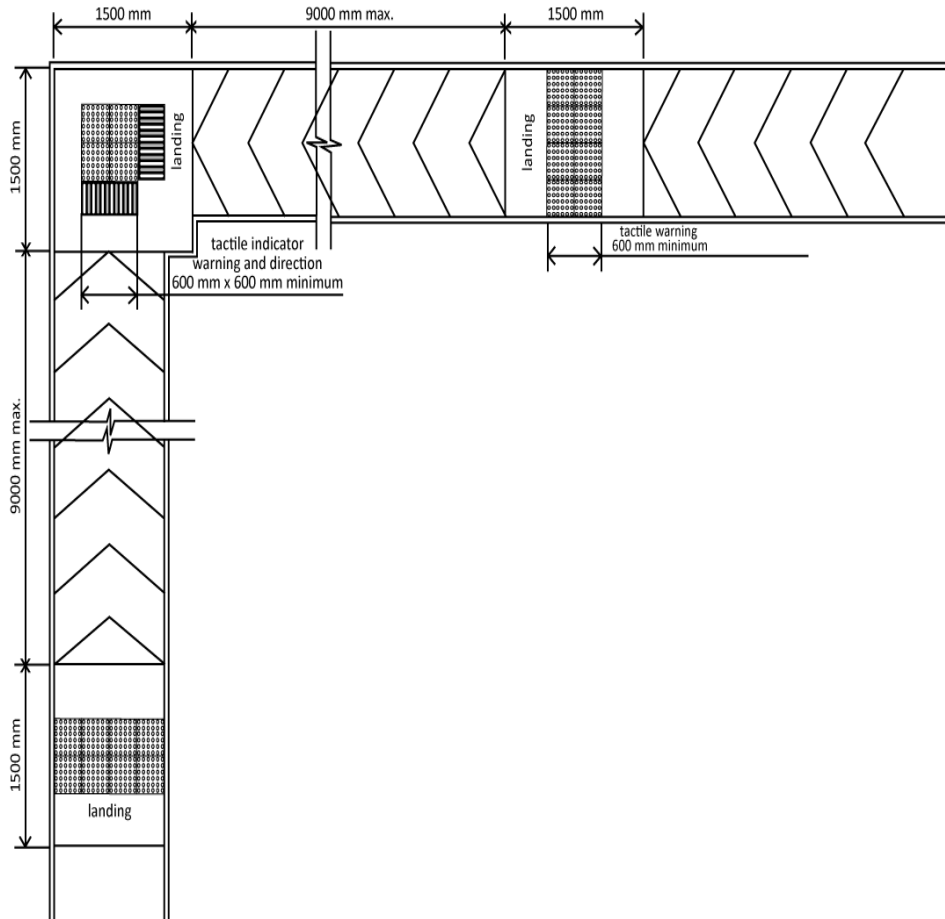


Figure 3.D.18 Plan of right-angled ramp and landing

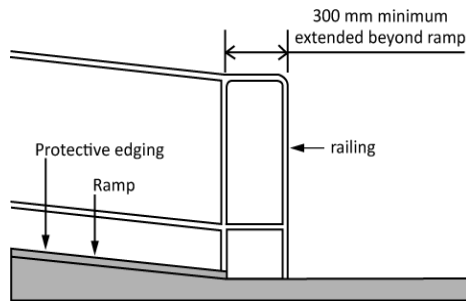


Figure 3.D.19 Hand rail extension (to floor or wall)

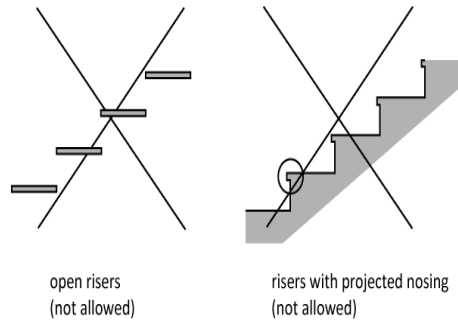


Figure 3.D.20 Stair detail

D.12.2 Tread, Riser and Nosing

All continuous flights of steps shall have uniform riser height of maximum 150 mm and tread width of minimum 300 mm. The risers shall be either vertical or receded back as per guidelines of Figure 3.D.21.

All steps should be fitted with contrasting visually detectable non-slip nosing as shown in Figure 3.D.21.

D.12.3 Warning Indicators

Stairs like any other level changes poses risks of accidents to persons with visual impairment. So all stairs in an accessible facility shall have detectable tactile warning strips provided at the top, bottom and intermediate landings in compliance to provisions of Sec D.29, Figures 3.D.21 and 3.D.22.

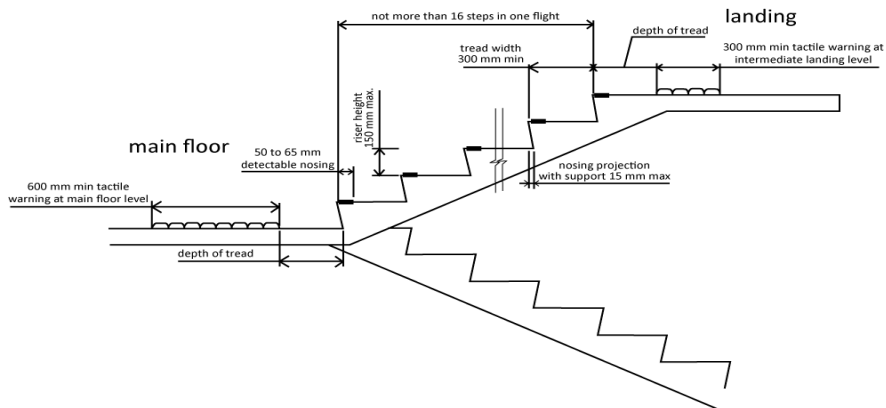


Figure 3.D.21 Tactile warning at beginning and ending of stairs and detectable edges

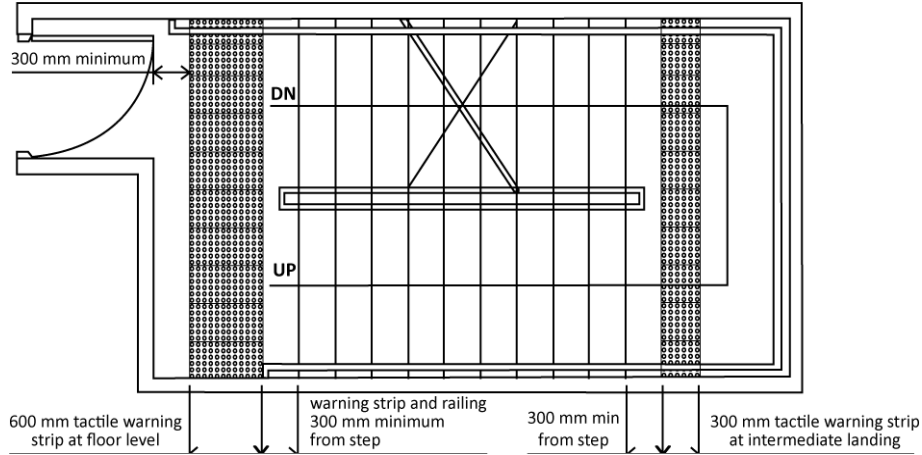


Figure 3.D.22 Tactile warning in staircase

D.12.4 Stair Handrails

Stair handrails shall comply with provisions of Sec D.9.2. Such handrails shall be installed on both sides of a stair as shown in Figure 3.D.23 and shall be installed between 800 mm and 900 mm height measured vertically from the pitch line of the steps to the top of the handrails. Stair handrails shall be continuous throughout the entire length of the stair and extend at least 300 mm beyond the top and bottom step as shown in Figure 3.D.23.

D.13 Accessible Seating Space and Counter Services

Any accessible seating space for wheelchair users such as work stations, tables, service counters in any building occupancy shall have a clear floor space not less than 900 mm x 1200 mm. Where a forward approach is required, the clear knee space shall be at least 900 mm wide, 480 mm deep and 700 mm high as shown in Figure 3.D.24. Writing surfaces or service counters shall not be more than 800 mm from the floor as shown in Figure 3.D.24.

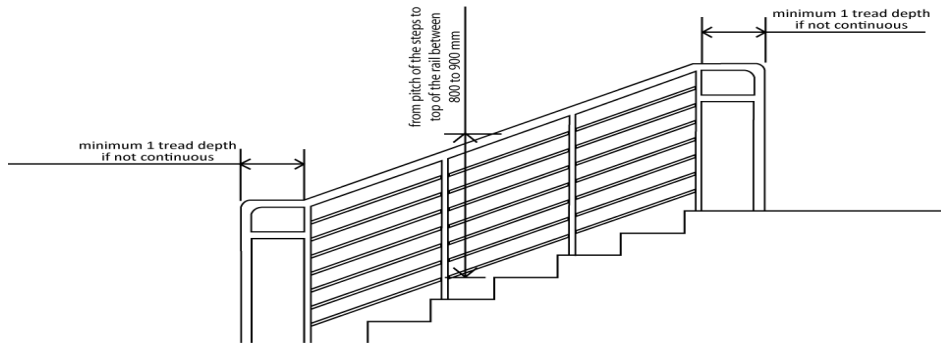


Figure 3.D.23 Handrail in stairway

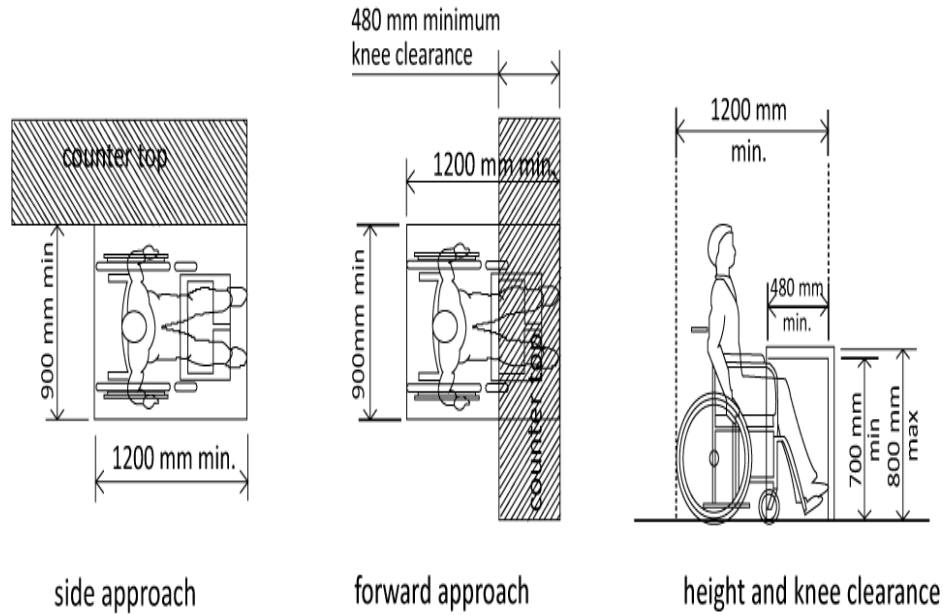


Figure 3.D.24 Forward or side approach to table or counter

D.14 Sanitary Provisions

D.14.1 General

In building occupancies described in Sec D.3, at least one toilet in each floor of a building or 5 percent of total toilets of the building, whichever is large, must be accessible. Among all accessible toilets preferably all or at least one shall be unisex in design provisions. The minimum dimension of an accessible WC compartment shall be 1500 mm x 1750 mm. All such toilets shall preferably have access directly from the accessible route. When they are part of a group of toilets, a clear approach path up to the accessible compartment with minimum of 1200 mm width shall be ensured. All accessible toilets shall have an emergency call button complying with the provisions of Sec D.17.

D.14.2 Fixtures and Accessories of Accessible Toilets

All fixtures in an accessible toilet shall abide by the provisions of this Section along with Sections D.16 and D.20 for minimum dimension, clearance from wall and other accessible clearances and limits along with minimum clear space for wheel chair maneuvering.

D.14.2.1 Accessible wash basin

All accessible basins shall comply with the provisions of Figure 3.D.25.

The faucets and other controls of such basins shall not involve powerful grasping or twisting of wrist and shall preferably be automatic or lever operated. If hot water provisions are there, proper insulation must be made to ensure safety of user.

D.14.2.2 Accessible water closet

The center line of a water closet in an accessible toilet shall maintain a distance of 460 mm to 480 mm from the adjacent sidewall. The front edge of such water closet shall be at least 750 mm away from the rear wall to allow side transfer for wheel chair users. The seating top shall have a height between 450 mm to 480 mm from the floor level. All such water closet shall have a back support to lean against it in the form of a seat lid or a flush tank or an added support. The flushing control if not automatic shall be located on the transfer side of the water closet. Figure 3.D.26 shows the basic requirements for such water closets.

D.14.2.3 Accessible urinals

Where urinals are provided, at least one shall be of wall hung type with a clear floor area of 750 mm x 1200 mm with level floor plane. The rim height of such urinals shall not be more than 400 mm measured from the floor. Any privacy shield on side shall have at least 120 mm clearance from the grab bars as shown in Figure 3.D.27. All such grab bars shall be installed as per provisions of Figure 3.D.27.

D.14.2.4 Washroom accessories

All washroom accessories such as towel rail, soap dispenser, waste bin, hand dryer, mirror, emergency call bell etc. shall be located within close proximity and shall comply with the provisions of Figure 3.D.28 and Sec D.17.

D.14.2.5 Signs at washroom entrances

All accessible toilets shall have clearly visible signs at washroom entrances complying with the provisions of Sections D.26.2 and D.27.

D.15 Doors of Accessible Washroom and Water Closet Compartment

Any door of an accessible washroom and water closet compartment in fully open position shall have an unobstructed opening of at least 900 mm. For such doors, pull and push bars, sufficient clearance at both pull and push side of the door for wheel chair maneuvering shall be provided in compliance with guidelines of Sec D.8, Figure 3.D.29 to 3.D.31. All doors for accessible washroom and water closet compartments should preferably swing outward.

D.16 Grab Bars

Any accessible toilet and bathing facility shall be mounted with at least two grab bars for each toilet fixtures except wash basin. The grab bars shall have a cross-sectional area complying with the provisions of Sec D.9. The length of such grab bars shall not be less than 600 mm. When both horizontal and vertical grab bars are required it is preferable that they should be continuous. All such grab bars shall follow the guidelines of Figure 3.D.28.

A horizontal grab bar mounted to the closest side wall of the water closet shall have a length starting from the rear wall and extending at least 450 mm beyond the front edge of the water closet and the same wall shall have a vertical grab bar as illustrated in Figures 3.D.31 to 3.D.33.

A foldable grab bar shall be mounted on the wider transfer side of the compartment as illustrated in Figures 3.D.26 and 3.D.29. Keeping a clearance of 380 mm to 400 mm from the center line of the water closet and same height with other grab bars. Foldable grab bars shall not extend more than 100 mm from the front edge of a water closet.

D.17 Emergency Call Bell

All accessible toilets, water closet compartments and wash rooms shall have a water proof emergency call bell in each compartment. Such emergency call bells shall be either push-button type or pull-chord type located for convenience of use at a height between 600 mm to 650 mm above the floor level. The buzzer of such call bells shall be so located that immediate attendance shall be available quickly.

D.18 Individual Water Closet Compartment

Any accessible water closet compartment for wheel chair users as required in Sec D.14.1 shall have a minimum internal dimension of 1500 mm x 1750 mm. All such water closet compartments shall comply with the provisions of Sections D.14.2.2, D.15, D.16, D.17, Figures 3.D.26 and 3.D.29.

D.19 Water Closet Compartment In Public Toilet

Any accessible water closet compartment for wheelchair users in a public toilet facility shall have a clear internal dimension of not less than 1500 mm x 1750 mm. All such water closet compartments shall comply with the provisions of Sections D.8, D.14.2.2, D.15, D.16, D.17 and Figure 3.D.30.

D.20 Bath Facilities

D.20.1 General

All residential occupancies, where accessible toilets are required by the provisions of Sec D.3, shall be provided with accessible bathing facilities either by providing bathtub complying with Sec D.20.2 or by providing shower stall complying with Sec D.20.3. Sports facilities and public swimming pools that need accessible provisions according to Sec D.3.1 shall also be provided with shower compartments in both male and female areas complying with Sec D.20.3.

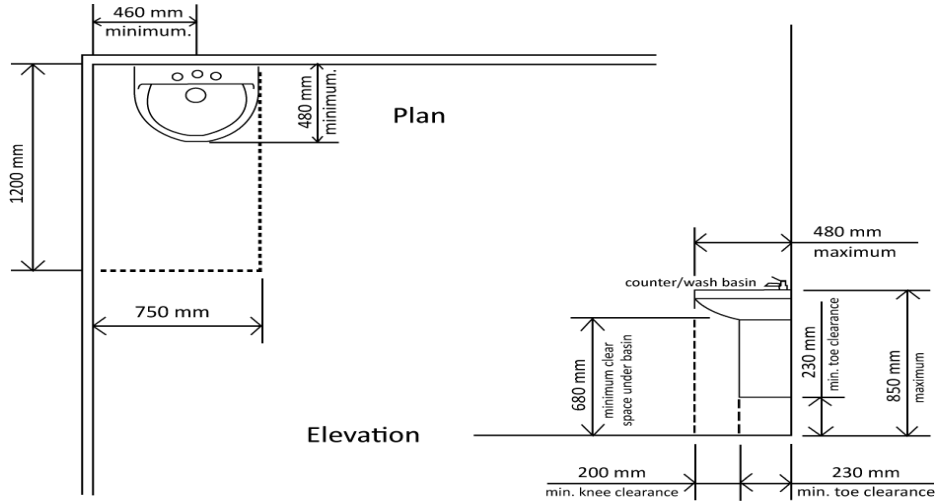


Figure 3.D.25 Details of accessible wash basin

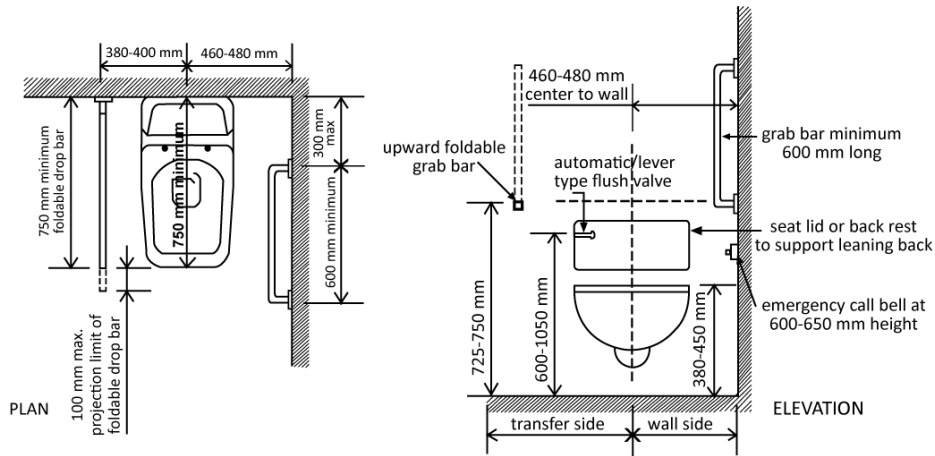


Figure 3.D.26 Accessible water closet for wheel chair users

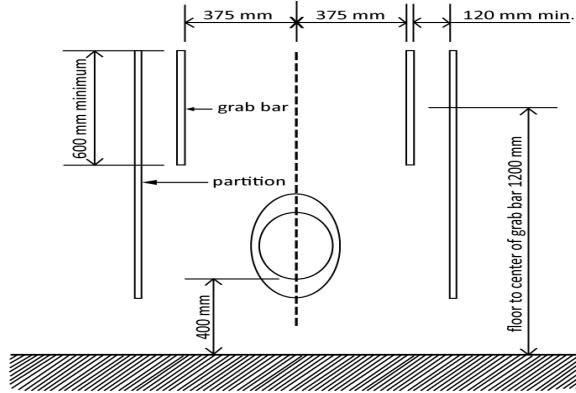


Figure 3.D.27 Basic dimensions for accessible urinals

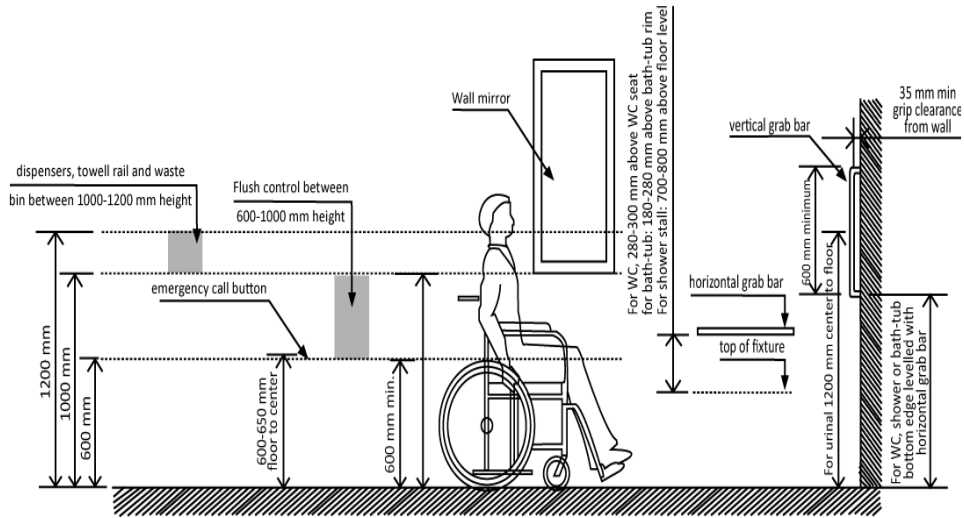


Figure 3.D.28 Standard dimensions for wash-room accessories and grab bars

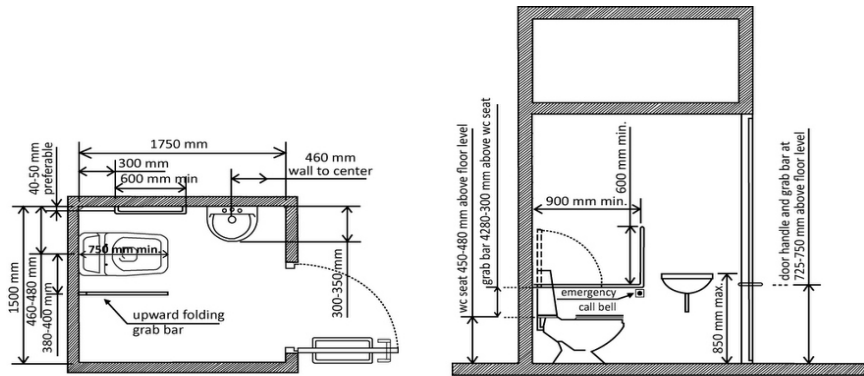


Figure 3.D.29 Water closet compartment for wheel chair users

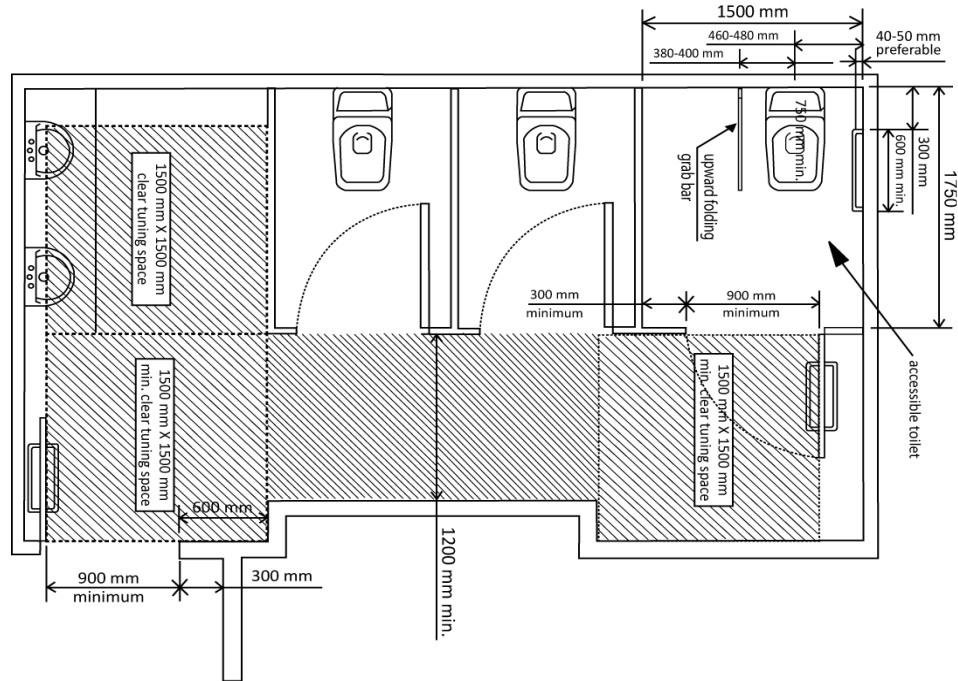


Figure 3.D.30 Detail of water closet compartment in group toilet

D.20.2 Accessible Bathtub

Any accessible bathtub shall have a clear floor space of at least 750 mm x 1200 mm along its length as shown in Figure 3.D.31. A seat of at least 250 mm width along the entire length or width of such bathtub as shown in Figure 3.D.31 and shall be required. The floor of accessible bathtubs shall be slip resistant. The base of such bathtubs shall be slip-resistant. All accessible bathing facility shall have grab bars complying with Sec D.9 and with the provisions of Figures 3.D.31 and 3.D.32. Shower heads in such facilities shall be hand-held type with flexible cords and shall comply with the provisions of Figures 3.D.31 and 3.D.32. All other accessories of such facilities shall comply with Sec D.14.2.4.

D.20.3 Accessible Shower Stall

An accessible shower stall shall have internal dimensions of at least 1500 mm x 1500 mm and shall comply with the provisions of Figure 3.D.33. The floor and seat of such accessible shower compartment shall be slip-resistant. The shower heads of such showers shall be hand-held type with flexible cord. All faucets and accessories of such shower compartments shall follow the guidelines of Sec D.14.2 and Figure 3.D.33. All such

shower compartments shall have grab bars in compliance with Sec D.9, Sec D.16 and Figure 3.D.33. Any level change of such floor shall not be more than 10 mm and shall be negotiated with a slope ratio of one vertical to two horizontal.

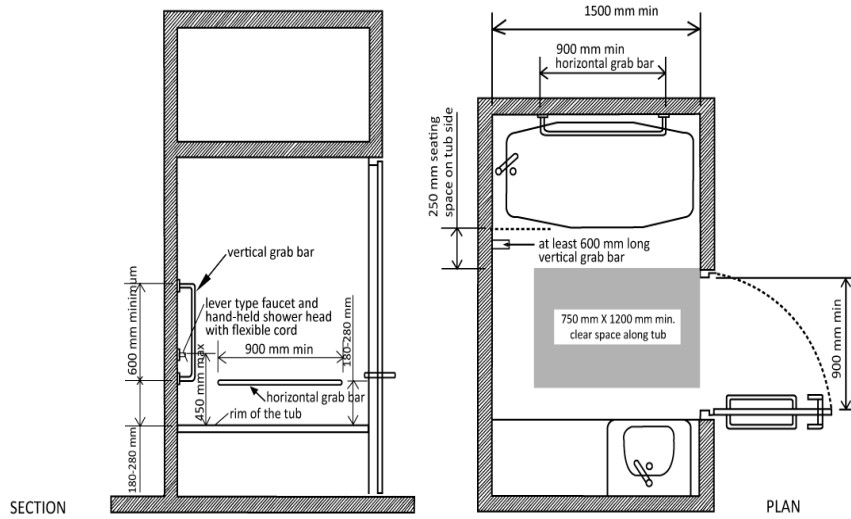


Figure 3.D.31 Bathing tub for persons with disabilities

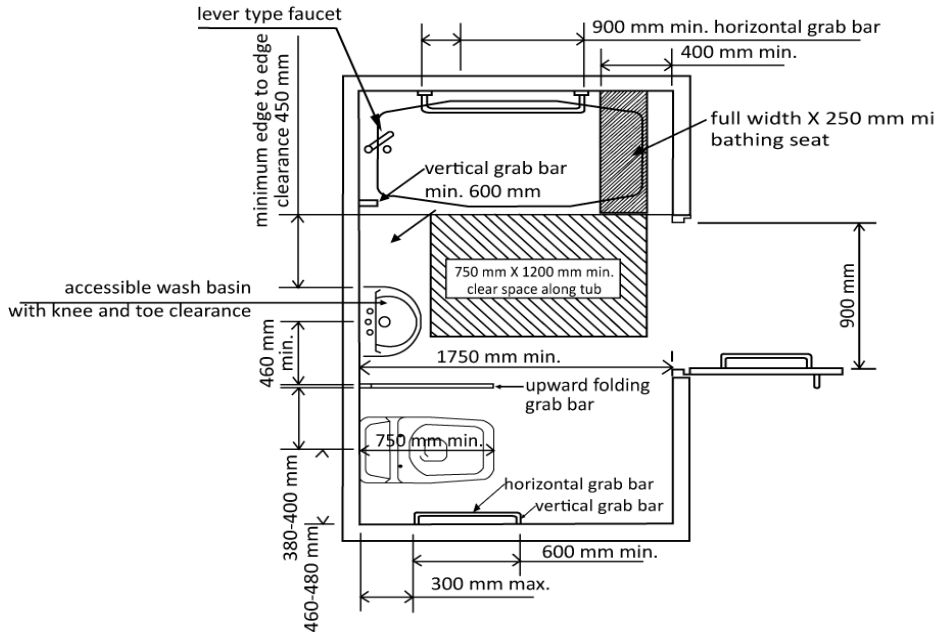


Figure 3.D.32 Layout plan for 3 fixture toilet

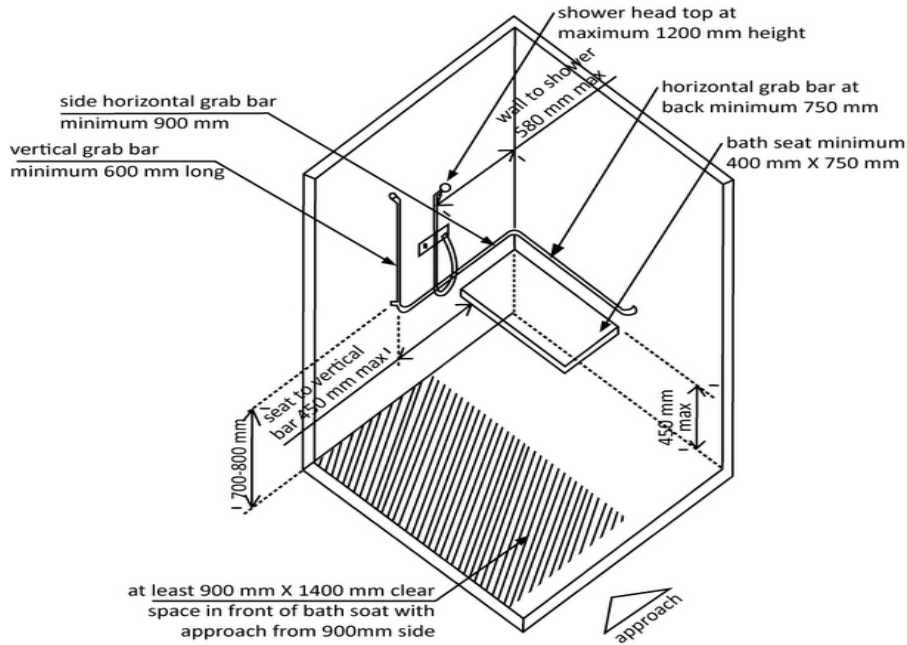


Figure 3.D.33 Accessible shower stall for wheelchair user

D.21 Kitchen Facilities

An accessible kitchen may have an open layout (e.g. pass-through type) or a closed layout (e.g. U-shaped). The open layout consists of a straight pass through aisle, which can be entered from both ends and where working top, appliances and cabinets are on two opposing sides as shown in Figure 3.D.34 (A). The clear width of such aisle shall be not less than 1015 mm.

The closed layout requires turning radius of a wheel-chair within the kitchen area resulting in a layout enclosed on three contiguous sides ensuring a minimum clearance of 1525 mm between all opposing cabinets, working tops, appliances and walls, as shown in Figure 3.D.34 (B).

All appliances shall be clearly approachable either by front approach or by parallel approach. Where a forward approach is provided, the clear floor or ground space shall provide knee and toe clearance as per provision of this Code. Knee and toe space under cooking range shall be insulated to prevent burns or abrasions or electrical shock. At least fifty percent of all cabinets and storage spaces shall be accessible as per provision of this Code. The height of the working top, sink, cooking range and all necessary appliances shall follow the guidelines for accessibility of this Code.

D.22 Lifts

D.22.1 General

Buildings, where lifts are needed as part of requirement by the building authority, should have at least one accessible lift for vertical circulation from the entrance level and serve all levels intended for use by persons with disabilities. Lift lobby for such facilities shall have a minimum dimension of 1500 mm × 1500 mm. The minimum size of an accessible lift car shall be 1500 mm × 1725 mm with a clear door opening of not less than 900 mm. Such accessible lifts shall follow the guidelines of Sec D.5 for floor finish, Sec D.9 for horizontal grab bar on back and side walls and the guidelines of Figure 3.D.35. All accessible lift shall have tactile marking and Braille on all buttons.

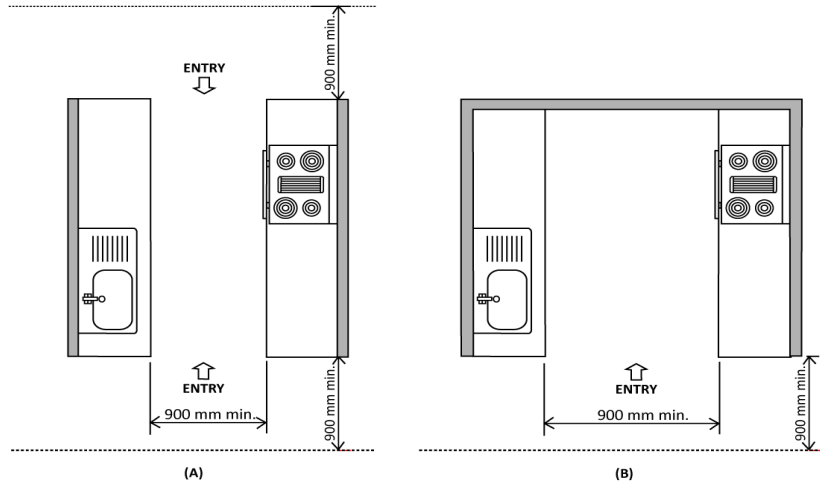


Figure 3.D.34 Accessible kitchen clearance

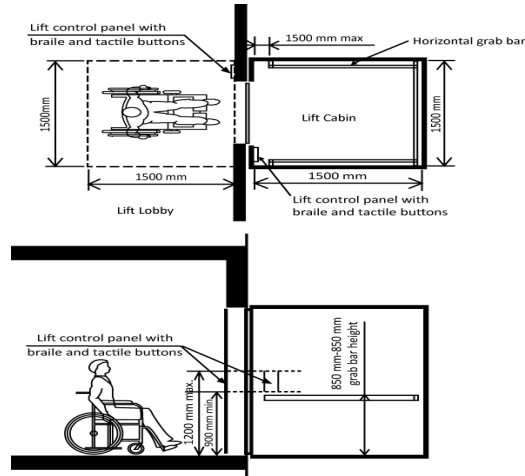


Figure 3.D.35 Lift for persons with disabilities

D.23 Eating Outlets

D.23.1 General

All eating outlets, with or without fixed seats, as mentioned in Sec D.3 shall have provisions of access for persons with disabilities complying with Sec D.23.2. Any aisle of circulation in such outlets shall be at least 1200 mm wide.

D.23.2 Seating

In an accessible eating outlet, the minimum clear space between seats in the required number of accessible tables shall be 750 mm measured along the edge of the table as shown in Figure 3.D.36. All such tables provided for persons with disabilities shall comply with provisions of Figure 3.D.37. All such tables should be clearly marked with accessibility symbol and shall have directional signage for indicating location.

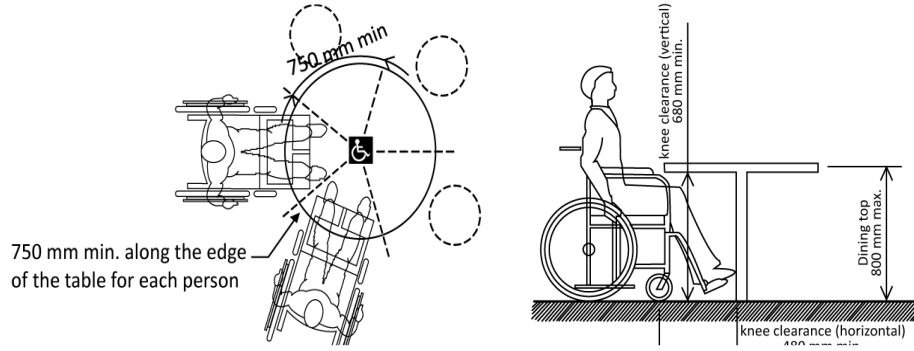


Figure 3.D.36 Space requirement for accessible seating Figure 3.D.37 Clearance for accessible seating

D.24 Accessible Parking Area

D.24.1 Parking Provision

In all occupancies referred in Sec D.3 where vehicle parking is required, the number of accessible parking stalls for vehicles for persons with disabilities shall be in accordance with Table 3.D.3. Such parking lots should be located as nearer as possible to the accessible entrance of the building. Pedestrian accessible routes connecting accessible parking shall be such that it avoids the risk of collision between an ambulatory disabled person and a backing out vehicle in a parking lot. Such parking shall not be occupied by vehicles of persons without disability.

Table 3.D.3: Minimum Number of Accessible Parking Stalls

Number of vehicle park stalls	Number of accessible stalls
For first 50 stalls	1
Next 400 stalls	1 additional stall per 100 parking stalls or portion thereof
Above 450 stalls	6

D.24.2 Symbols and Signage

Each accessible parking stall shall be clearly designated with the symbol of access, in accordance with the requirements of Sec D.26.2.

Such Symbol shall be painted in contrasting color at the center of the accessible parking stall, having a dimension between 1000 mm × 1000 mm to 1500 mm × 1500 mm and complying with provisions of Sec D.26.2.

The symbol of accessible parking shall be displayed at all approaches and entrances of parking lot indicating the location of such parking within the lot. Directional signs shall be displayed at every change of direction to direct persons with disabilities or their vehicle to the point of accessible parking stall.

D.25 Accessible Vehicle Parking Stalls

The minimum dimension of an accessible vehicle parking stall shall be 4800 mm × 3200 mm. All such parking shall be provided on a firm, non-slippery, leveled solid surface and if possible, be covered. Figure 3.D.38 shows the detail of an accessible parking stall.

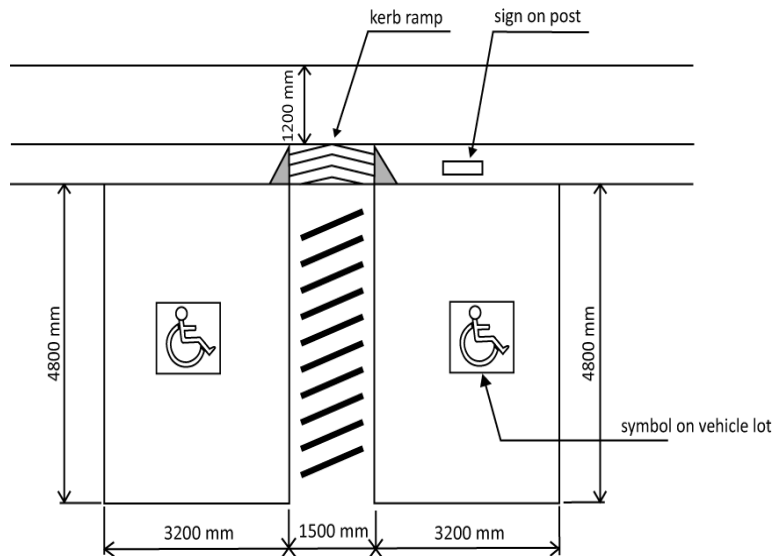


Figure 3.D.38 Accessible parking stall and approach

D.25.1 Signage

Any accessible parking lot shall be identified by the symbol of access in accordance with Sec D.26.2. The size and location of all signs should be such that they ensure clear visibility all along the accessible route.

D.26 The Symbol of Accessibility

D.26.1 General

The Symbol of Accessibility is an internationally accepted language that shall be permanently and clearly displayed to indicate and/or direct to the location of various accessible facilities in and around a building. All buildings or facilities mentioned in Sec D.3.1 shall display the required symbol of accessibility in compliance with the guidelines of this Code. Any such signs and symbols shall be simple, short and easy to understand. The text and use of pictographs shall be consistent throughout the building and outdoors in any accessible facility.

D.26.2 Symbol of Access

The form of the symbol of access shall consist a symbolized figure on a wheelchair and a contrasting plain square background as shown in Figure 3.D.39 where the symbolized figure shall be white on a blue background and shall always face to the right.

Any building that offers accessible facilities shall clearly display the symbol of access at road front. Inside the premise the symbol shall denote the location of the accessible facilities including accessible parking, accessible routes, entry and other accessible services and facilities for persons with disabilities.

D.26.3 Directional Signs

Whenever changes in direction occurs directional signs incorporating the symbol of access similar to Figure 3.D.40 shall be displayed. This shall include main lobbies, passageways and all points where there is a change of direction to direct persons with disabilities to various accessible functions and facilities such as lifts, entrances, toilets, car parks and the like.

Where the location of the designated facility is not obvious or is distant from the approach viewpoints, directional signs incorporating the symbol of access, as shown in Figure 3.D.41, should be placed along the route leading to the facility.



Figure 3.D.39 Symbol of access for persons with disabilities



Figure 3.D.40 Accessible directional sign

D.26.4 Service Identification Signs

Every accessible route shall contain service identification signs showing appropriate symbol of accessibility for persons with disabilities, as shown in Figure 3.D.42, to indicate the presence and direction to various service facilities such as entrances, lifts, telephone booths, toilets, vehicle parks, staircases and the like. Tactile pictographic signs shall distinguish between male and female toilets.



Figure 3.D.41 Signs directing to facility



Figure 3.D.42 Service Identification Signs at Destination

D.27 SIGNAGE

D.27.1 Specifications for Characters and Symbols

Letters and numbers, when put on signs shall be legible and shall be consistent in font type all along the accessible facility. Only 'CAPITAL LETTER's shall be used in such signage. Braille, if written, shall be located directly below the text or arrow in a signage.

D.27.2 The Size of Symbols

The size of symbols depending upon the distance, it is intended to be first viewed from shall vary and shall be in accordance with Table 3.D.4.

Table 3.D.4: Size of symbols varying with distance

Viewing distance (m)	Symbol size (mm)
Up to 7.0	60 × 60
7.0 to 18.0	100 × 100
Above 18.0	200 × 200 to 450 × 450

D.27.3 The Height of Letters

The height of letters in signs depending upon the distance, it is intended to be viewed from shall vary and shall be determined in accordance with Table 3.D.5.

Table 3.D.5: Height of letters varying with distance

Required viewing distance (m)	Minimum height of letters (mm)
1.5	50
2.0	60
2.5	100
3.0	120
4.5	150
6.0	200
8.0	250

D.27.4 Location of Signs

All signs shall be located such that they are clearly and legibly identifiable from an accessible route. Any change of direction in an accessible route shall always contain necessary directional signs for users. In case of internal signs the center line of the sign shall be at a height within the field of vision and preferably at 1500 mm above the floor level.

D.27.5 Tactile Characters or Symbols

Tactile characters or symbols when used on a sign shall have a size between 16 mm to 50 mm and shall be raised at least 0.8 mm above the background surface. All such signs shall be mounted at a height complying with Sec D.27.4.

D.27.6 Braille and Pictographs

When Braille, the tactile language, is used the Braille dot shall be raised in dome shape from the base and the sign shall be easy to touch and read. The height of all such signs shall comply with Sec D.27.4.

Pictographs, when used shall be supported by equivalent textual description placed directly below it.

D.28 Grading of Slip Resistance

For the purpose of accessibility, surface materials to be used as floor finishes should be graded for slip resistance in both dry and wet conditions. Table 3.D.6 indicates the slip resistance of some commonly used finish materials.

Table 3.D.6: Slip resistance grading

Grading	Co-efficient of surface friction	Example
Very good	More than 0.75	Clay tiles, carpets, dry rubber
Good	Between 0.75 to more than 0.4	Concrete pavers, dry terrazzo tiles, dry marble and granite
Poor to Fair	Between 0.4 to 0.2	Wet and polished terrazzo tiles, marble and granite
Very poor	Less than 0.2	Wet rubber

D.29 Tactile Ground Surface Indicators

D.29.1 Path of Travel and Mobility

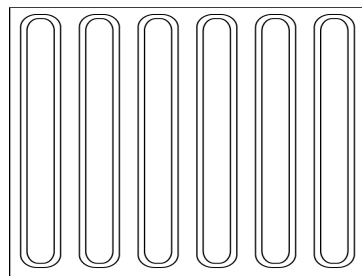
People with different forms of visual impairments can be assisted to find their way independently with the help of some physical or sensory cues e.g. landmarks and mind maps. For such users a predictable, logical and barrier free access route is required. Therefore all such path of travel dedicated to universal accessibility should be designed as free from barriers, hazards or obstructions along with physical and sensory cues for such users.

D.29.2 Physical Cues

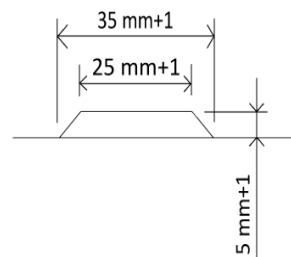
Physical cues are designed elements including buildings, walls, ground surfaces, railings, fences and curbs that can act as cues or clues to assist a visually impaired person. Such persons can identify physical cues either by use of a white cane, under foot, or by echo-location. All public buildings referred in Sec D.3 shall have physical cue both inside and outside the building to assist visually impaired persons.

Tactile ground indicators are designed physical cue to convey two important indications to visually impaired persons- a. directional indications and b. caution or warning indications.

Directional indicators, Figure 3.D.43, act as physical cues to guide persons with visual impairment to travel through an accessible route free from obstructions from beginning to end.



(a) Directional indicator: top view



(b) Directional indicator section detail

Figure 3.D.43 Directional indicators on ground of accessible route

Warning indicators are physical cues for warning users of an adjacent hazard or a destination. Such hazards include but not limit to level changes, change of direction, approaching vehicular roads, obstructions etc.

The pattern and dimensions of warning indicator are shown in Figure 3.D.44 (a) and (b).

Figure 3.D.45 shows the combined use of both directional and warning tactile indicators in an accessible route.

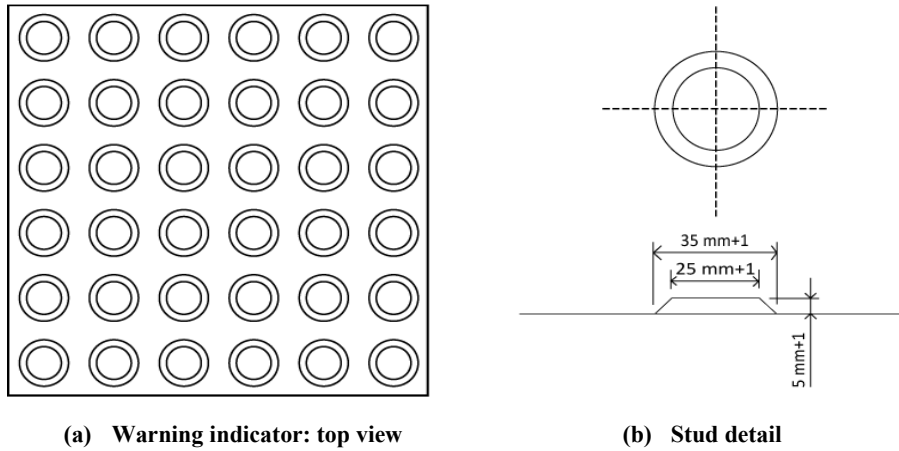


Figure 3.D.44 Warning Indicators on ground of accessible route

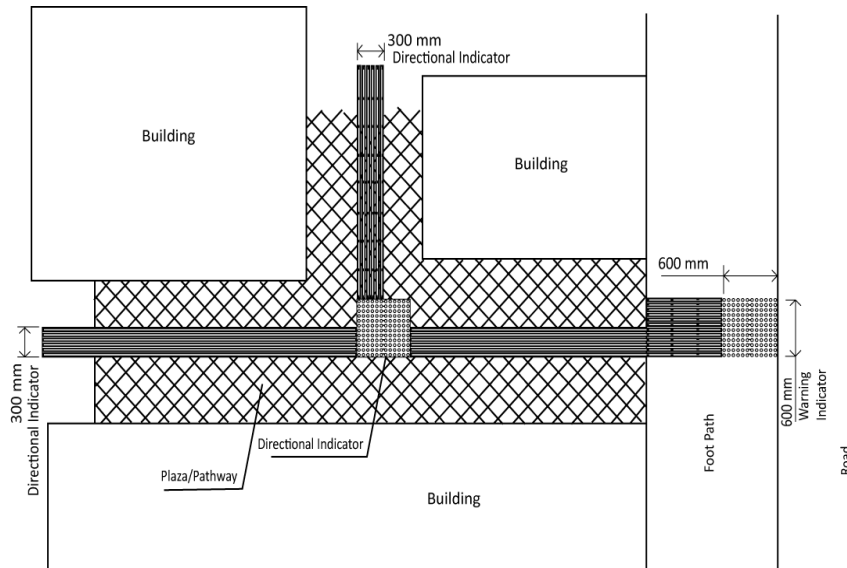


Figure 3.D.45 Use of tactile indicators in accessible route

PART III
Appendix E

Building Types, Development Rights and Buildings Abutting Property Lines

E.1 General

These guidelines cover the planning and general building requirements of different building types such as attached type, detached type, semi-detached type etc. regarding their development rights and rights regarding building on abutting property lines. These requirements are applicable to all occupancy types taken up by public, private or co-operative agencies.

E.2 Definition and Typology

The following are some definitions and diagrams to explain different typologies and terminologies relevant to this Code:

E.2.1 Row Type Building

A row type building abuts two side plot party-lines and is one of a row of buildings on adjoining zoning lots. The end buildings of a row of attached buildings are considered semi-detached buildings if they each have minimum side setback. Here the rest two (non-abutting) sides of the building are surrounded by yards or open areas within the plot confirming at least to minimum setback requirements (Figure 3.E.1).

E.2.2 Semi-detached Building

A semi-detached building is a building that abuts one side on the party-line of a plot and does not abut any other building on any other side of any adjoining plot/s; here the rest three (non-abutting) sides of the building are surrounded by yards or open areas within the plot confirming at least to minimum setback requirements (Figures 3.E.2 and 3.E.3).

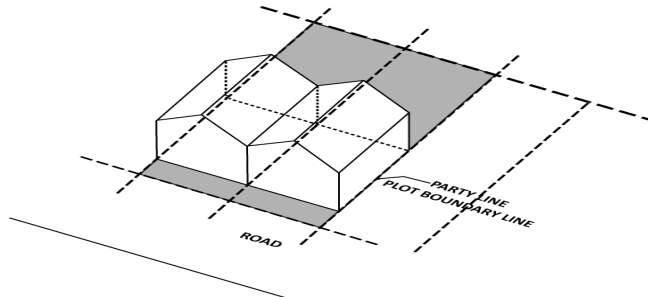


Figure 3.E.1 Row type buildings

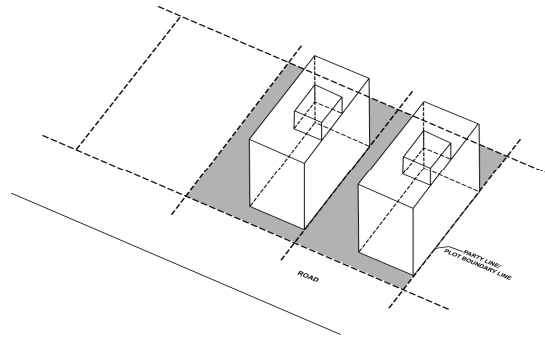


Figure 3.E.2 Semi-detached building (not abutting neighboring building)

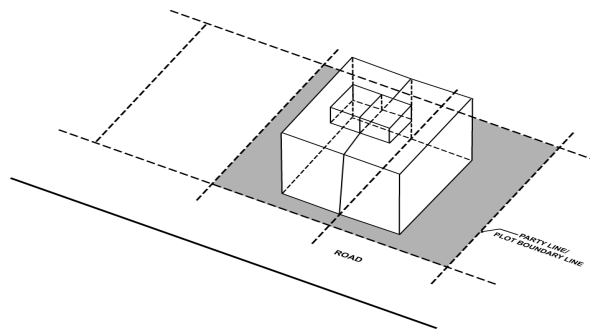


Figure 3.E.3 Semi-detached building (abutting neighboring building)

E.2.3 Detached Building

A detached building is a freestanding building that does not abut any other building on an adjoining plot and where all sides of the building are surrounded by yards or open areas within the plot conforming at least to minimum setback requirements.

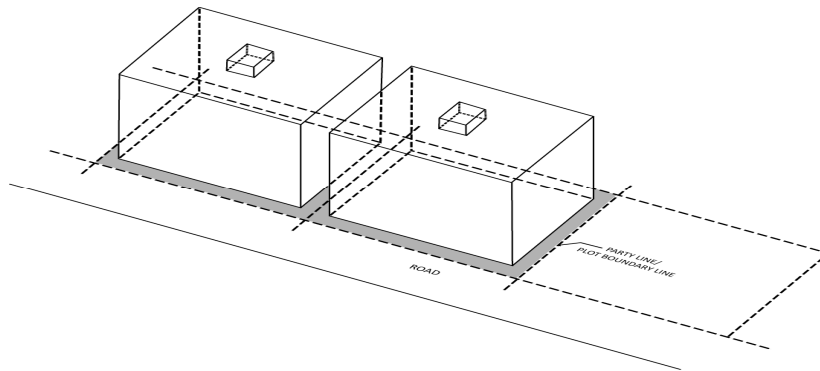


Figure 3.E.4 Detached building

E.3 Special Provisions For Construction of the Wall Abutting Parti-Line/ Site Boundary Line

E.3.1 General Requirements

Walls abutting any parti-line shall have no opening.

A parti-wall shall not contain any concealed lines (water, gas, sanitary, electricity etc.).

A parti-wall shall be so constructed that it remains moisture free, leak proof and confirms to the fire safety requirements as referred in Part 4.

A parti-wall shall conform with structural guidelines for earthquakes and pounding gaps given in Chapter 1, Part 6 of this Code. When the adjacent buildings are designed separately, pounding gaps are mandatory. When adjacent buildings are designed and built in an integrated way through plot consolidation, no such gap is required.

E.3.2 Shared Parti-Wall

A parti-wall, if formally (in written form) agreed upon between two adjoining owners, may become a shared wall between the two properties built half on the land of each of the two owners or in such other position as may be agreed between the two owners, with both having equal rights on the use of that wall. In such cases the structural guidelines of this Code shall be abided by both parties to allow future modifications on either side of the party-wall.

E.3.3 Independent Parti-Wall

For all other cases, the owner who intends to build a parti-wall, shall make it wholly on his own land abutting the parti-line or plot boundary line and shall reserve individual right/s (not shared) of use of that wall. Parti walls, in such cases, are one or two walls abutting parti-line or having pounding gap as per structural requirement of Part 6 built on same or different times.

E.3.4 Non-Crossing of Parti/Property Line

Under all circumstance, above ground or underground, the foundation/ footing of any wall/ column or any other part of building or services, shall not cross the parti-line or plot demarcation line.

E.3.5 Foundation of Parti-Wall

For all foundation work the safety of the buildings on adjoining land or plot must be ensured. The building owner who intends to erect wall abutting the side parti-line, if necessary shall, at his own expense underpin or otherwise strengthen or safeguard the foundations of the building or structure of the adjoining property.

E.3.6 Structural Independence

Buildings with parti-wall on adjacent plots must be structurally independent. Depending upon the plot frontage and the choice of structural system a parti wall may also be non-structural or non-load bearing wall. Where parti-wall or any part of it is structural, the footing/foundation provisions must comply with Part 6 of this code.

E.3.7 Utility Lines and Drainages**E.3.7.1 Underground or surface lines and drainages**

For all underground/concealed utility pipe lines, drains, ducts, etc., the outer edge of such utility pipe lines/ drains/ ducts shall be at least 900 mm inside from the parti-line within the plot to ensure maintenance accessibility without hampering parti-wall or the adjacent neighbor. For all such lines provisions for easy maintenance must be kept beforehand.

Any surface drain/ inspection pit (on finished ground level) shall be at least 250 mm inside from the parti-line within the plot.

E.3.7.2 Vertical utility lines or drainages

Under all circumstances, vertical utility lines/ducts shall not cross the parti line or plot demarcation line. No pipes, gutters, spouts, surface holes or any other type of drainage outlet to the adjoining properties can be given; special measures shall be taken to contain all drainages within the site.

E.3.7.3 Prevention of leakage

Any leakage or infiltration from these lines to neighbouring property must be prevented during and after construction. For such leakages the landowner who owns such utility lines shall be responsible to repair and compensate for any damage thereby.

For two adjacent walls abutting the same property line, the gap in between must be properly sealed.

E.4 Other Requirements

With the exception of clauses mentioned above, requirements of building will be governed by the provision of this Code and good practice.

Measures must be taken for prevention of infiltration of rain, dust and moistures through joineries of parti-walls with pounding gaps between two adjoined properties. Proper treatment for damp proofing and termite proofing in compliance with Part 6 shall be ensured. Chemical treatment to prevent long term growth of fungi and other microbial forms are recommended on such walls.

A parti-wall shall be a barrier wall in compliance with the guidelines of Part 4 to ensure fire safety of the adjoining property. Other requirements of fire safety, structural design, building services and plumbing services shall be as specified in this Code.

PART III
Appendix F
Road Hierarchy, On-Street and Off-Street Parking

F.1 Introduction

Road is an integral part of a settlement and its land-use planning. For public safety in any new development the hierarchy of road network with measures for gradual traffic calming and adequate safe parking, both on-street and off-street, are of vital importance. Road width and road components, junctions, features of controlling vehicles' speed and turning, forward visibility and visibility splay at junctions are important tools of traffic and speed control.

With increased density and parking demand, on-street parking shall be an important tool to increase overall parking capacity as well as accommodation for service vehicles (e.g. garbage collection vehicle, maintenance vehicles etc.). This measure is also expected to keep the pedestrian walkways free from unauthorized vehicular parking.

F.2 DEFINITIONS

CARRIAGEWAY	Refers to driveway that provides access to the parking place. They do not have parking stalls adjacent to them.
CARRIAGEWAY RAMPS	Refers to inclined floors that provide access between two levels.
INSIDE LANE	Refers to the innermost lane of a curve ramp, which is nearest to the center point of curve.
INSIDE RADIUS OF LANE	Refers to curved carriageway and driveway is the distance measured from the inside curve edge to the center point of the curve.
MAXIMUM GRADIENT	Refers to the steepest gradient of ramp measured along the center line of the ramp. Gradient refers to the ratio of the inclination of the ramp (height length).
OUTSIDE LANE OF CURVED CARRIAGEWAY	Refers to any lane positioned after the innermost lane.
PARKING AISLE	Refers to an access lane or driveway with adjacent parking stalls.
PARKING ANGLE	Refers to the angle measured between the longer side of the parking stall and the line of traffic flow of the aisle.

PARKING STALL	Refers to the space required for parking of one vehicle. The space of the stall shall be rectangular. The area of each stall shall be flat and free from curbs and other obstructions.
SINGLE-LANE	Refers to a lane where only one vehicle can pass through at any given time.
TRAFFIC FLOW	Refers to the direction of vehicle movement.

F.3 Road Hierarchy Guidelines For New Development

For any new development, at least three hierarchically interlinked road patterns should be followed (Figure 3.F.1): a. primary road, b. secondary road and c. internal/ access/ residential road. Though it is not mandatory to provide wider than regulation pedestrian walkways (with provisions for street furniture), bicycle lane and plantation zones parallel to walkways, it is strongly recommended that such provisions should be made, especially at primary and secondary road level, as much as possible.

Primary Road: This refers to a Public way or portion thereof, on which vehicular traffic is given preferential right-of-way, and at the entrance to which from intersecting public ways is required to be in obedience to a traffic signal, stop sign, or yield sign as per traffic code. Primary roads connect settlements/ zones/ sectors with rest of the city, which are capable of and usually are serviced by public transport facility (e.g. Bus service, Tram service etc.). These roads define the edge of the settlement and shall be capable of hosting traffic interchange (e.g. changing from one mode of transport to another). No individual plot should be accessed directly from a primary road (Figure 3.F.2). The right of way of a primary road shall not be less than 18 meter (Table 3.F.1 and Figure 3.F.3).

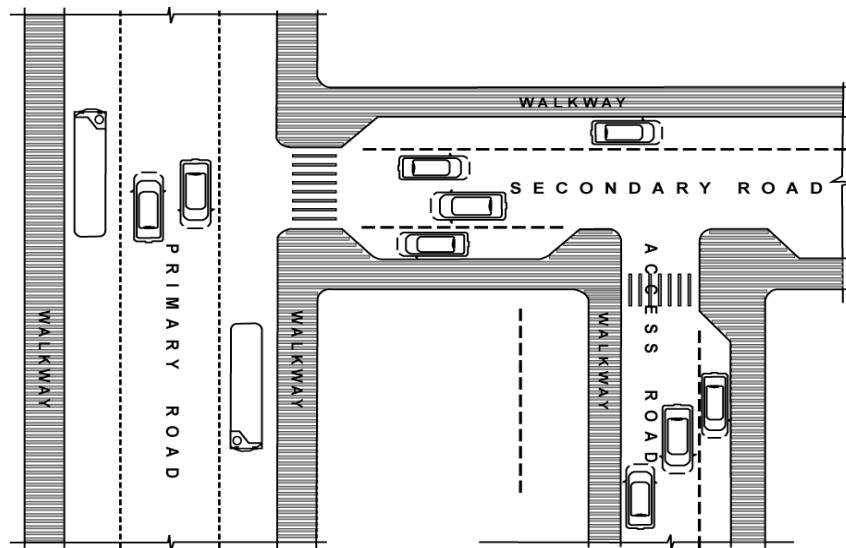


Figure 3.F.1 Road hierarchy

Secondary Road: A secondary Road is a collector road or distributor road of low to moderate-capacity, which serve to move traffic from internal/local streets to primary/arterial road. The flow of a collector road usually consists of a mixture of signaled intersections or traffic circles with primary arterial roads or other collector roads and un-signalized intersection with local/internal/residential roads.

A secondary road shall not be less than 13.5 m (Table 3.F.1 and Figure 3.F.4).

Internal/access/residential road: At the bottom of the hierarchy are local/Internal/ access streets and roads. These roads have the lowest speed limit, carry low volumes of traffic and often have pedestrian priority. The minimum width of such road will depend on the density of the adjacent plots (Table 3.F.1, Figure 3.F.5).

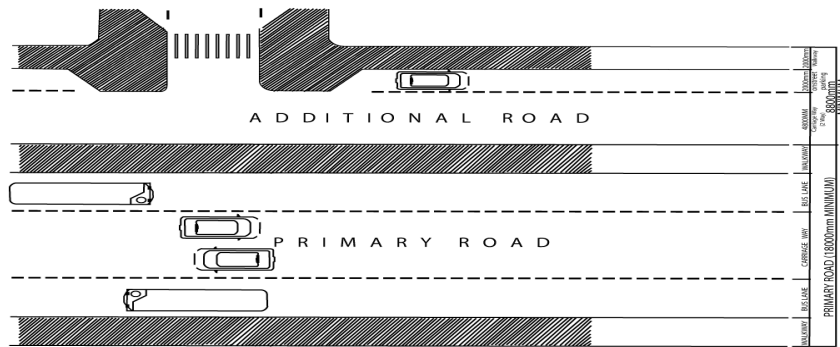


Figure 3.F.2 Parking beside primary/arterial road

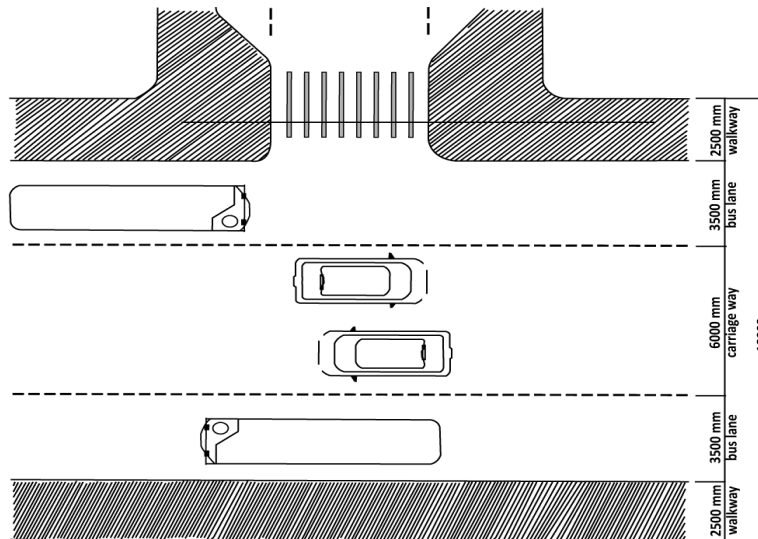


Figure 3.F.3 Minimum dimensions for primary road

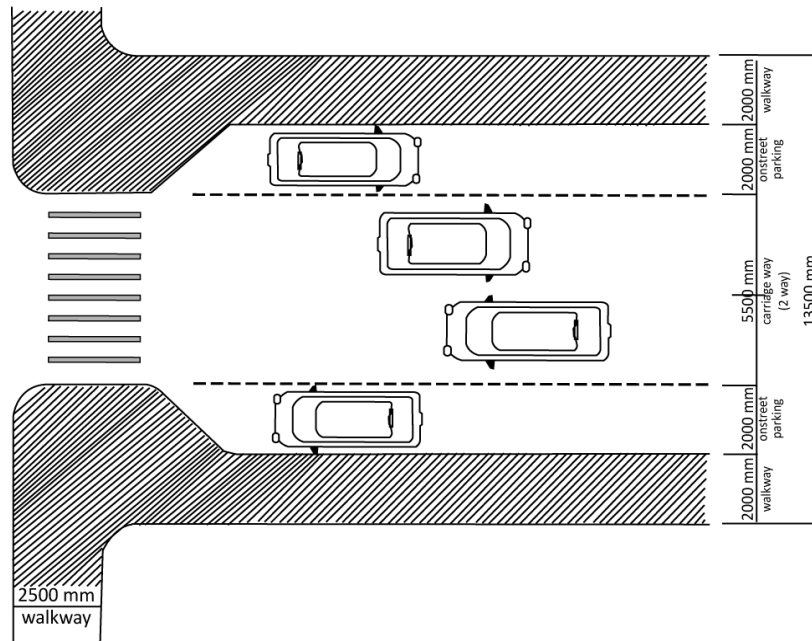


Figure 3.F.4 Minimum dimensions for secondary road

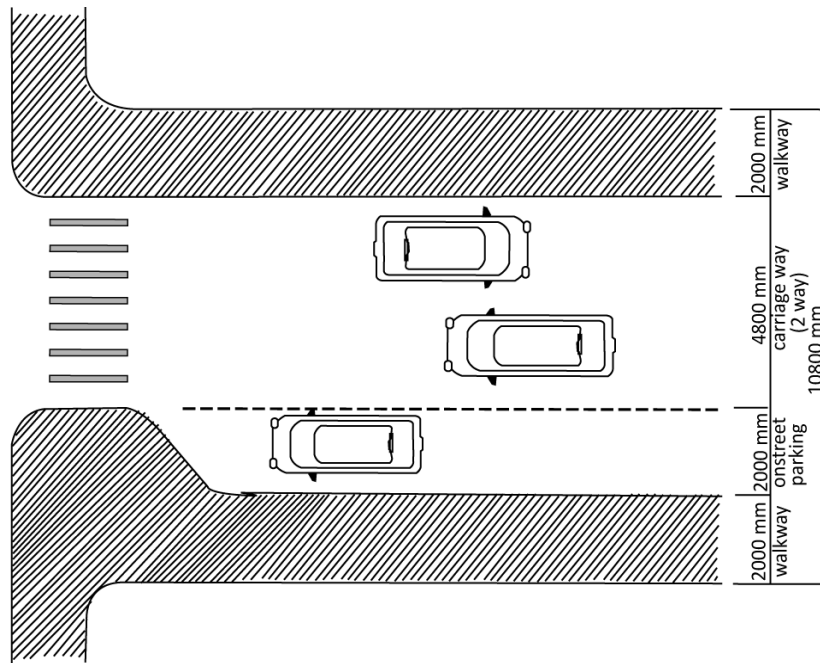


Figure 3.F.5 Minimum dimensions for Internal/access/local/residential road

F.4 Guidelines For Pedestrian Walkway

F.4.1 Any pedestrian path should be part of a pedestrian network connecting building users to different facilities and part of a city or a settlement and should enhance pedestrian friendly environment.

F.4.2 Pedestrian path or walkways should be separated and protected from vehicular driveways and any conflict between vehicular and pedestrian crossing shall be designed to ensure pedestrian safety.

Table 3.F.1: Minimum Widths of Public Means of Access to Residential Plots of new development

	2-way vehicular road width	On-street Parking/ Emergency Vehicle	Pedestrian walkway	Bus Lane / Bus Stop	Minimum right of way/ ROW Option-A*	Minimum right of way/ ROW Option-B**	Minimum right of way/ ROW Option-C***	Minimum right of way/ ROW Option D****
	V (m)	P (m)	W (m)	B (m)	V+W (m)	V+2W (m)	V+P+2W (m)	
Main/ primary road (V+2W X 1.25+2B)	6	Nil	2	3.5	Nil	Nil	Nil	18.00
Secondary road (V+2P+2W)	5.5	2	2	Nil	Nil	Nil	Nil	13.5
Internal/ access road	4.8	2	2	Nil	6.8	8.8	10.8	Nil

Note:

* For serving residential occupancy A1 and A2, the minimum right of way shall be option A

** For serving residential occupancy of A3 within walkup range the minimum right of way shall be option B

*** For serving residential occupancy of A3 above walkup range, the minimum right of way shall be option C

**** For serving residential occupancy of A3 in mixed use, the minimum right of way shall be option D

F.4.3 The minimum width of a pedestrian walkway which is not enclosed by adjacent walls on both sides shall be 1 m; otherwise the minimum width shall be 1.25 m. However, depending upon the frequency of pedestrian users the recommended minimum width for footpath or walkway shown in Table 3.F.2 may be followed.

F.4.4 All public transport terminal and stoppages shall have dedicated planning for pedestrian users to and from the facilities showing connection to the public pedestrian and vehicular network adjacent to the site. Pedestrian walkways or footpaths in all such facilities shall be of sufficient width to cater the pedestrian need of the facility.

Table 3.F.2: Recommended minimum width of pedestrian walkway based on frequency of use

Peak pedestrian frequency (pedestrian user per minute)	Width of walkway (m)	Width for street furniture and plantation (m)	Total recommended width (m)
Up to 60	2.5	1.5	4
Above 60- 80	3.25	1.5	4.75
Above 80- 100	4.0	1.5	5.5
Above 100	5.0	1.5	6.5

F.5 Guidelines For On-Street Parking

For on-street car parking in any new settlement, the guidelines of Table 3.F.1 shall be the minimum requirement depending upon the type of road and expected traffic density.

F.5.1 Parking along Primary Road

For primary roads, fast moving uninterrupted traffic flow needs to be ensured. Therefore such roads shall not serve for on-street parking. If, parking besides such primary roads becomes necessary, then an additional carriageway with on-street parking and an additional pedestrian walkway as shown in Figure 3.F.6 may be planned, keeping the main traffic flow uninterrupted.

F.5.2 Parking along Non-Primary Roads

On-street parking should normally only be considered on local distributors and roads lower in the hierarchy. On such roads, on-street parking spaces may be provided where off-street facilities are inadequate to meet demand and where provision would not adversely affect the flow of traffic. On-street spaces should generally cater for short term parking needs and parking meters may be installed to encourage such usage.

F.5.3 Parking for Service Vehicles

In most situations, it will not be necessary to provide parking spaces specifically for service vehicles, such as delivery vans, which are normally stationary for a relatively short time. If such parking bays are considered necessary, other vehicles may need to be prevented from using the spaces by regulation and enforcement.

F.5.4 Omission and Conversion of Existing Parking

Omission and conversion of existing parking spaces shall not be permitted if it results in parking deficiency for the occupancy type. That is, after omission and conversion, the remaining number of parking spaces must be sufficient to meet the minimum requirement of the existing, proposed and approved development.

F.5.5 Parking Design Considerations

Any parking space design will consider the following two factors :

- (a) Minimum parking requirement ascertained for each type of occupancy
- (b) Parking layout for the required number of parking (Figures 3.5.7 to 3.F.13)

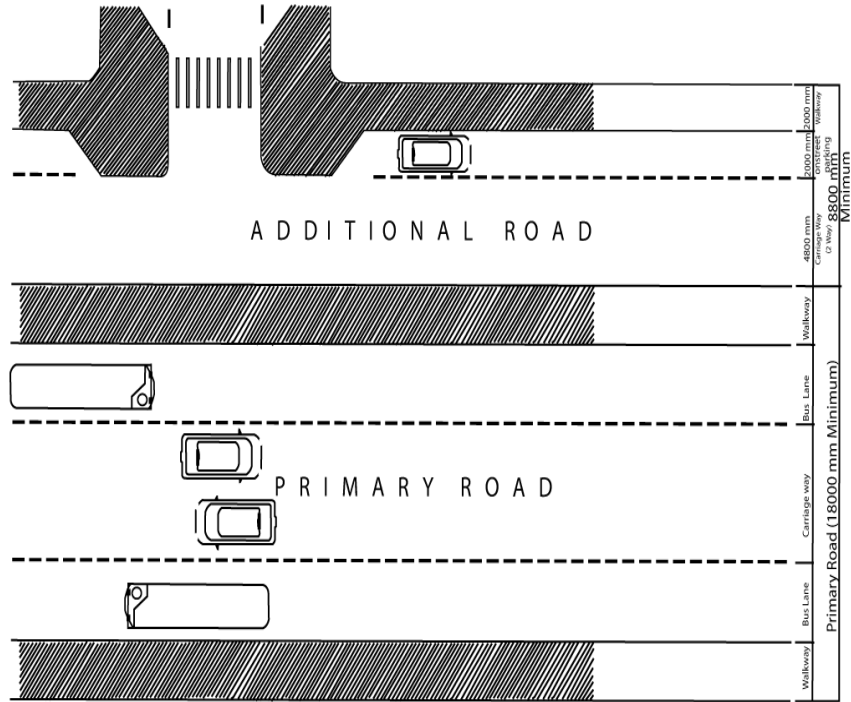


Figure 3.F.6 Provision for on-street parking beside primary road

F.6 Minimum Requirement For off-Street Parking

The number of minimum parking spaces required shall be based on the total floor area of the building and shall depend on its occupancy type and number of users. The following tables (Table 3.F.3) shall form the basis for computation of minimum parking requirement:

Table 3.F.3: Off-street parking requirements for different occupancies

Occupancy type/use		Minimum off-street parking requirements
Residential (occupancy type-A)	Residential (occupancy type-A) Small private dwellings/ row house with plot size not more than 134 m ²	1 car parking
	Small private dwellings/ row house with plot size 134-268 m ²	2 car parking
	Multi-family housing with flats/ apartments with gross area more than 200 m ²	1 car parking/unit+5% guest parking
	Flats/ apartments with gross area more than 140 m ² to 200 m ²	2 car parking per 3 units
	Flats/ apartments with gross area more than 90 m ² to 140 m ²	1 car parking per 2 units
	Flats/ apartments with gross area more than 60 m ² to 90 m ²	1 car parking per 4 units
	Flats/ apartments with gross area up to 60 m ²	1 car parking per 8 units
	Flats/ apartments with gross area up to 90 m ² (in addition to required car parking)	1 motorcycle parking per 5 units
	Hotels (star category)	1 car parking per 5 guest rooms
	Hotels (other category)	1 car parking per 200 m ² gross area
	Others	1 car parking per 300 m ² gross area
	The minimum parking requirements for all residential occupancies within 500 m radius of MRT or BRT stations shall be 25 percent of the calculated requirement from above.	
Educational (Occupancy type-B)	Educational (Occupancy type-B)	1 car parking per 200 m ² gross area
	Kindergarten, primary schools, high schools, colleges, tertiary educational institution, training centers, universities and other educational institutions.	For plots with 25 m or more frontages, an uninterrupted dropping bay of at least 25 m length and 4.25 m width shall be given at ground level within the school premises. For plots with less than 25 m frontage, an uninterrupted dropping bay with length equal to total frontage of the plot and 4.25 m width shall be given at ground level within the school premises. At primary and secondary schools there should be a minimum of 3 lay-bys for school buses within the school boundary.

Occupancy type/use		Minimum off-street parking requirements	
Institutional and Health care Type (Occupancy type-C and D)	Institutional Type (Occupancy type-C)	1 car parking per 200 m ² gross area	
	Hospitals, clinics (Occupancy type-D)	1 car parking per 5 beds	
	Medical diagnostic centers	1 car parking per 100 m ² gross area	
	Others (outdoor treatment facilities, collective practice of physicians etc.)	1 car parking per 200 m ² gross area	
Business and Mercantile (Occupancy type-E and F)	Mercantile (Occupancy type-F) Shops, department store	1 car parking per 200 m ² gross area 1 loading/ unloading bay of heavy goods vehicle per 2000 m ² gross area or portion thereof	
	Restaurants	1 car parking per 100 m ² gross area	
	Business (Occupancy type E) and Offices	1 car parking per 200 m ² gross area	
	Others	1 car parking per 200 m ² gross area	
Industrial (Occupancy type-G) and Storage (Occupancy type-H)	Industries (Occupancy type-G) Storage (Occupancy type-H)	For all such installations, at least 1 truck parking along with loading unloading bay and at least 1 car parking. For administrative or sales centers within these installations, 1 car parking per 200 m ² for such parts only are required.	
Assembly (Occupancy type-I)	Assembly (Occupancy type- I) Cinema	1 car parking per 40 seats	
	Theatre, auditorium	1 car parking per 20 seats	
	Sports facilities	1 car parking per 200 seats	
	Transportation terminals, airports, railway stations, etc. (Occupancy I or MIXED)	1 car parking per 50 m ² gross area	
	Wedding/ party center (Occupancy I or MIXED)	1 car parking per 25 m ² gross area. For plots with 25 m or more frontage, an uninterrupted dropping bay of at least 25 m length and 4.25 m width shall be given at ground level within the school premises.	
	Religious structure	Up to 300 m ²	At least 1 car parking
		More than 300 m ²	1 car parking per 50 m ² gross area
Others		1 car parking per 200 m ² gross area	

Occupancy type/use		Minimum off-street parking requirements
Hazardous (Occupancy type-J)	Hazardous (J1 and J2)	For all such installations, at least 1 truck parking along with loading unloading bay and at least 1 car parking. For administrative purpose within these installations, 1 car parking per 200 m ² for such parts only are required.

Note:

For mixed-use situation, parking requirement shall be calculated by adding up the individual parking requirements of each types based on their use area per floor and respective parking ratio for each type.

For different types of flats/apartments within the same complex, parking requirements shall be determined by determining requirement for each type separately and then adding them together.

Fractional results in parking calculation shall be considered as 1 (one) full parking space.

With recommendation from the permitting authority parking requirement for low income residential areas may be reduced.

For flats with area less than 90 m², parking requirement of 1/3rd requirement of cars can be calculated by combining cars and motorcycles in the ratio of 1 car to 2 motorcycles.

For any building type, at least 1 (one) car parking shall be required.

F.7 Car Parking Layout Guidelines

F.7.1 Parking Stalls

Parking stall is a rectangular space with defined length and width, where the length is subject to variation depending on its relationship with the aisle, Figure 3.F.7.

For perpendicular or angular parking, the minimum dimensions required of a car parking stall shall be:

Stall width: 2400 mm

Stall length: 4800 mm

For parallel parking minimum dimensions required of a car parking stall shall be:

Stall width: 2000 mm

Stall length: 6000 mm

For parallel parking, where cars cannot be parked by reversing, minimum stall length shall be 7200 mm; the floor of each stall shall be flat and free from curbs and other interferences.

Where parallel parking stalls have frontal obstruction or perpendicular parking stalls have side obstruction, the stall sizes will vary in accordance with guidelines of Figure 3.F.8.

F.7.2 Minimum Width of Driveway

The minimum width of parking aisle or driveway shall follow the requirements of Table 3.F.4.

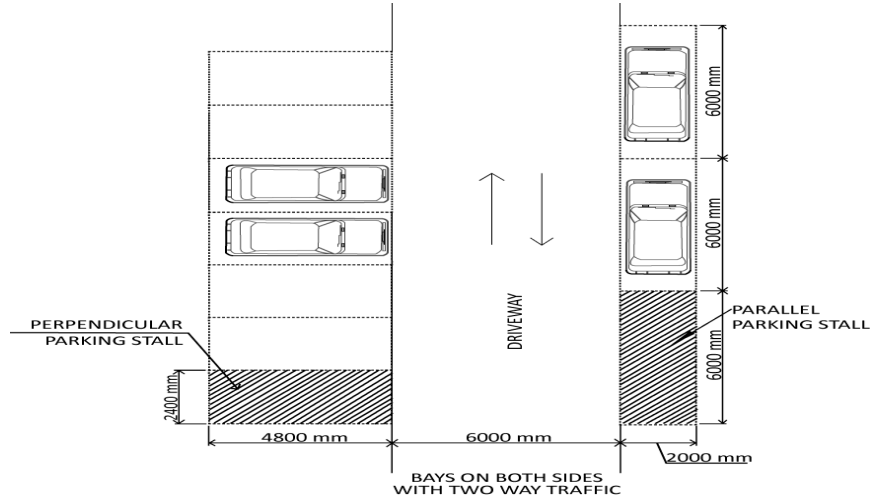


Figure 3.F.5 Parking stall requirements

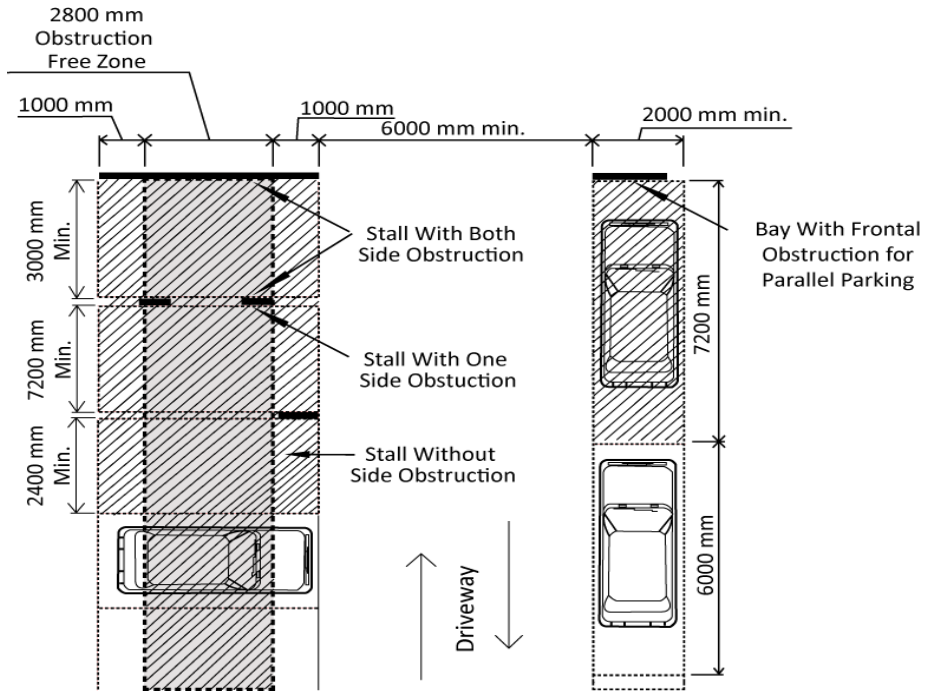


Figure 3.F.8 Parking stall size variation due to obstructions

Table 3.F.4: Minimum width of Parking Aisle/Driveway

Parking Angle to Aisle	One Way Traffic		Two Way Traffic
	Bay on One Side	Bays on Both Side	Bays on One or Both Side
0° (parallel)	3600	3600	6000
30°	3600	4200	
45°	4200	4800	
60°	4800	4800	
90° (perpendicular)	6000	6000	

F.7.3 Minimum Dimension for Carriageway Ramps

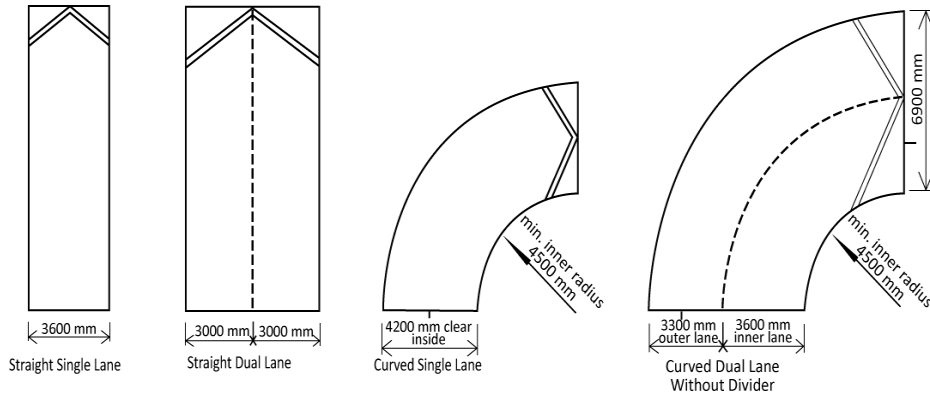
Carriageway ramps are sloped driveway connecting and providing access between two levels for vehicles. For safe maneuvering of vehicle on carriageway ramp guidelines of the subsections as under shall be followed.

F.7.3.1 Width of carriageway ramp

The width of a carriageway ramp shall comply with the guidelines of Table 3.F.5 and Figure 3.F.9.

Table 3.F.5: Minimum width of Carriageway Ramps

Type of Carriageway Ramp	Single Lane	Dual Lane	
(a) Width of straight carriageway ramp	3600 mm	6000 mm (3000 mm/lane)	
(b) Width of lane of curved carriageway ramp	4200 mm	3600 mm for inside lane	3300 mm for outside lane
(c) Inside radius of curved carriageway ramp	4500 mm		

**Figure 3.F.9 Carriageway ramp width**

F.7.3.2 Carriageway ramp gradient

Ramp gradient specify the slope of a ramp expressed either in percentage or in ratio and calculated as follows:

$$\text{Ramp gradient (slope)\%} = \frac{\text{Floor-to-floor height} \times 100}{\text{Ramp length along the horizontal plane}}$$

For same gradient on ramps, as shown in Figure 3.F.10 (a), the maximum slope shall be 12.5 percent (or 1 : 8). Ramp gradient shall be measured along the center line of the ramp.

For change of gradient on ramp, as shown in Figure 3.F.10 (b), this slope may be increased up to maximum 20 percent, with transition slopes on both end that are sloped at half of the slope of the main ramp.

F.7.3.3 Parking ramp

When sloped parking stalls are directly approached from a same sloped ramp it is known as parking ramp and the maximum gradient of such ramps shall be 5 percent (or 1 : 20).

F.7.4 Minimum Headroom

The height clearance from parking level floor to the bottom of the ceiling above shall be 2400 mm minimum. However, for downward projection from overhead ceiling (e.g. beams, direction signs, sprinkler heads, electrical fittings etc.) the clearance shall be minimum 2200 mm. Figure 3.F.11 shows the variable gradient of ramps used for calculating changing gradients.

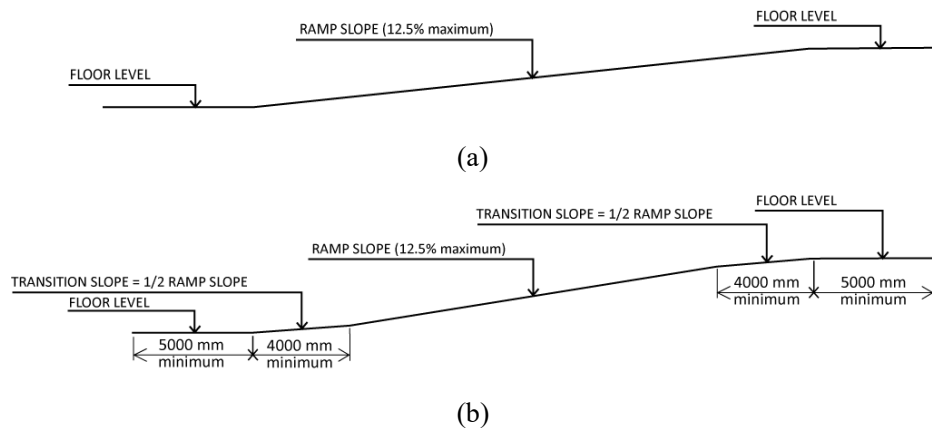


Figure 3.F.10 Ramps with (a) Same gradient; (b) Change in gradient

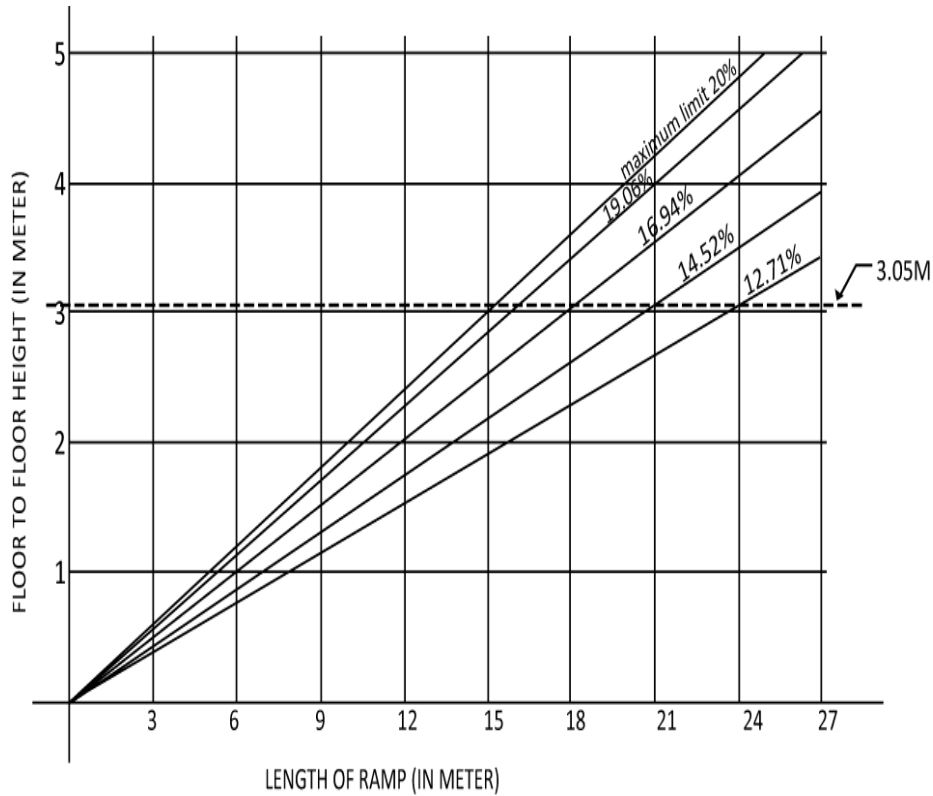


Figure 3.F.11 Relationship between floor-to-floor height, ramp gradient and ramp length

F.8 Motorcycle Parking Provisions

F.8.1 Motorcycle Parking Stall Dimensions

The minimum stall length and stall width of motorcycle parking shall be 2400 mm and 1000 mm respectively.

F.8.2 Stall Location

Motorcycle parking stalls can be provided at corners or any available space within the parking area provided that they do not obstruct movement of other vehicles and pedestrians.

F.9 Provisions For Large Vehicles

For other vehicles the minimum dimension of parking stall, headroom clearance, carriageway width and turning radius shall be in compliance with Table 3.F.6.

Table 3.F.6: Minimum Requirements for Large Vehicle Parking and Maneuvering

Type of Vehicle	Stall Length	Stall Width	Headroom clearance	Minimum carriageway width	Inside turning radius	Maximum ramp gradient ratio
Light goods vehicles e.g. pickup, vans etc.	7 m	3.5 m	3.6 m	4.5 m (single straight lane) 5.5 m (single curve lane) 7.4 m (dual straight lane)	6.0 m	1:12
Mini buses	8 m	3.0 m	3.3 m	4.5 m (single straight lane)		
Buses	12 m	3.5 m	3.8 m	7.5 m (single curve lane) 7.4 m (dual straight lane)		
Heavy goods vehicle e.g. trucks	11 m	3.5 m	4.7 m			
Articulated vehicles e.g. container carriers, trailers etc.	16 m	3.5 m	4.7 m	4.5 m (single straight lane) 9.0 m (single curve lane) 7.4 m (dual straight lane)		1:15

F.10 Provisions For Car Lift and Mechanized Parking

F.10.1 General

To connect between different levels with vehicular access, car lifts can be used instead of a carriageway ramps. However, where a site is so constrained that it is not technically feasible to place a conventional ramp to connect between levels, mechanized parking may be installed. All such parking shall require queuing space as per provisions of this Code.

F.10.2 Guidelines for car lifts in a parking

A car lift shall have two openings, allowing entry of a car from one direction and exit of the car to the opposite direction. After entry to a facility or a building having car lifts, a minimum queuing space for at least 15 percent of the total parking shall be provided within the site. On departure from site, at least one holding bay having equal space of a parking stall shall be provided within the site (Figures 3.F.12 and 3.F.13).

The internal dimension of all such lifts shall not be less than 2600 mm x 6200 mm with a minimum discharge capacity of 30 vehicles per hour. For every 50 vehicles 1 car lift shall be installed. To reduce queue at least two lifts shall be installed in a facility or a building. Maximum number of parking using car lifts shall not exceed 200.

F.10.3 Guidelines for Mechanized Parking

A mechanized parking may involve stacking system or lateral displacement system or a combination of both. The approach driveway width for a mechanized parking shall be at least 3.6 meter for one-way traffic and 6.0 meter for two-way traffic. After entry to a facility or a building having mechanized parking, a minimum queuing space for at least 5 percent of the total parking shall be provided within the site.

Mechanized parking varies widely in type and specification; and shall be installed according to its manufacturer's specifications. In doing so and during its operation it shall not compromise the safety of the building or the users in any way.

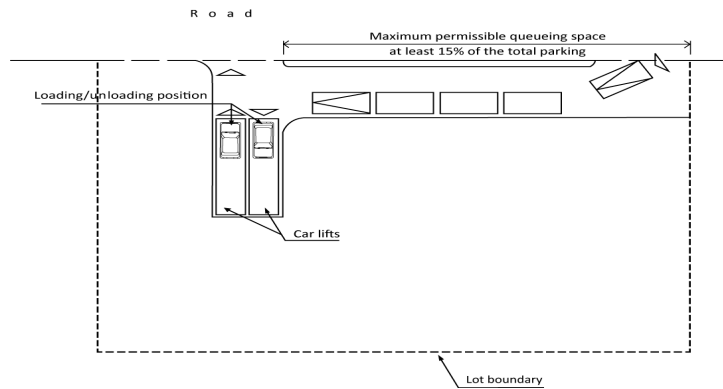


Figure 3.F.12 Queuing space and loading from and unloading to same road

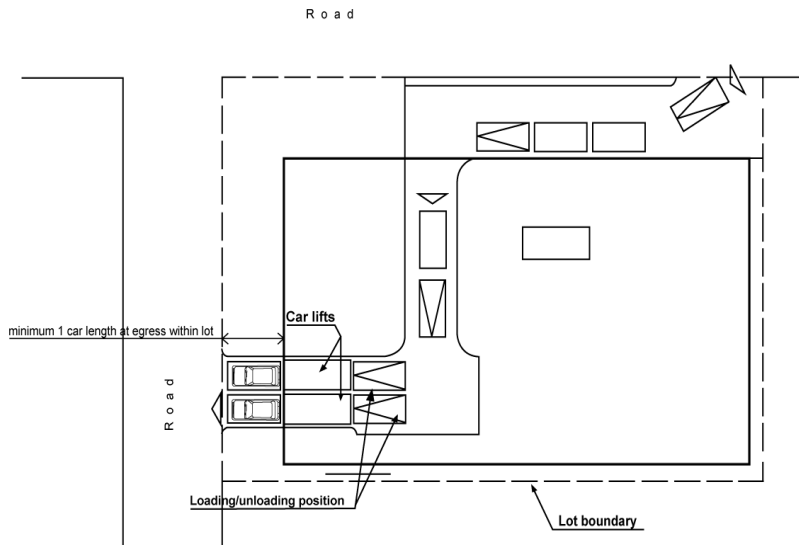


Figure 3.F.13 Queuing space and loading from and unloading to different roads

PART IV
Chapter 1
General Provisions

1.1 Scope

This Part of the Code prescribes regulations for safeguarding life and property in the use or occupancy of buildings or premises from the hazards of smoke and fire, and explosions. The provisions of this Part include general requirements of fire protection, precautionary requirements, means of egress, equipment and in-built facilities standard installations required for firefighting, and firefighting arrangements required for all occupancy groups.

1.2 Terminology

This Section provides an alphabetical list of the terms used in and applicable to this Part of the Code. In case of any conflict or contradiction between a definition given in this Section and that in Part 1, the meaning specified in this Part shall govern for interpretation of the provisions of this Part.

ALARM CONTROL UNIT	It consists of a circuit, controls, relays, switches and associated system which receive signals from alarm initiating devices and transmit to alarm signaling devices.
ALARM INITIATING DEVICE	An equipment operated manually or automatically which, when activated, initiates an alarm through an alarm signaling device.
ALARM SIGNAL	Signals of audible or visual in nature, indicating the existence of a fire and/or smoke condition. Audible devices may be bells, horns, chimes, speakers or similar devices. Visual Alarms is a strobe light emitting bright white light with approved insanity.
ALARM SIGNAL DEVICE	The equipment that produces the alarm signal.
ALARM SYSTEM	It is a combination of compatible devices, which when activated with necessary electrical energy can produce an alarm in the event of fire.
ALARM ZONE	It describes a defined area of the building or buildings for alarm initiating locations.

ANNUNCIATOR	Equipment capable of indicating the zone or area of a building from which an alarm has been initiated or the location of such devices and the operational condition of alarm circuit of the system.
AUTOMATIC FIRE DETECTING AND ALARM SYSTEM	These include all types of fire detecting and alarm signaling devices which activate themselves during a fire without manual intervention. The equipment/devices include temperature sensitive fuses, thermostat, fluid filled tubes and electronic devices which can detect a fire and transmit automatic alarm signals.
AUTOMATIC SPRINKLER SYSTEM	The system consists of an array of pipe-works fitted with fusible solder or glass bulb. This system shall activate at a predetermined temperature and the required water shall be fed to the system from any source. In the event of fire or smoke the system shall activate automatically by sensing the temperature of fire and discharge water to extinguish. These devices also actuate an audible alarm automatically.
AUTOMATIC HIGH VELOCITY WATER SPRAY SYSTEM	This system applies water in the form of a conical spray consisting of droplets of water discharged at high velocity through specially designed projectors to extinguish fire by emulsification, cooling and smothering.
BUILDING	Any structure used or intended for supporting or sheltering any use or occupancy.
BUILDING, EXISTING	A building erected or officially authorized prior to the effective date of the adoption of this edition of the Code by the agency of jurisdiction.
CARBON DIOXIDE EXTINGUISHING SYSTEM	This installation consists of a group of one or more cylinders of carbon dioxide, interconnected by a manifold and feeding into a system of high pressure distribution pipe work fitted with special discharge nozzles.
COMBUSTIBLE MATERIAL	Any material which burns and enhances the magnitude of fire.
DRY-CHEMICAL EXTINGUISHING SYSTEM	This system consists of specially designed pipe works and discharge nozzles linked to the dry powder containers and gaseous cylinders which are automatically/manually operated in case of fire.

DRY RISER	A riser or standpipe system is normally kept empty of water, but is capable to discharge water within 45 seconds and its installation is equivalent to wet-riser system.
ELEVATOR EVACUATION SYSTEM	A system, including a vertical series of elevator lobbies and associated elevator lobby doors, an elevator shaft(s), and a machine room(s), that provides protection from fire effects for elevator passengers, people waiting to use elevators, and elevator equipment so that elevators can be used safely for egress.
ELEVATOR LOBBY	A space from which people directly enter an elevator car(s) and to which people directly leave an elevator car(s).
EXTERIOR STAIRWAY	A stairway in which at least one side have openings more than 50% in an Exterior wall in such a way that there shall be no accumulation of smoke during fire.
FIRE BARRIER	A fire-resistance-rated wall inside a building, designed to restrict the spread of smoke and fire. Opening in that wall, shall be protected by fire protected doors or windows.
FIRE COMPARTMENT	A space within a building that is enclosed by fire barriers on all sides, including the top and the bottom to limit the transfer of fire.
FIRE DAMPER	A device installed in air ducts or air transfer openings or any openings designed to close automatically upon detection of fire or smoke.
FIRE DOOR	See Fire door assembly.
FIRE DOOR ASSEMBLY	Any combination of door leaf, frame, hardware and all other accessories that together provide a specific degree of fire and smoke protection to the opening where it is placed.
FIRE RESISTANCE RATING	It expressed as a period of time and denotes the property of a building construction material or elements and/or construction as a whole during which the materials or elements or constructions are (a) resistant to collapse due to fire, (b) resistant to flame penetration and (c) resistant to excessive temperature rise to the unexposed surface.
FIRE SEPARATION	Refers to a fire-resistance-wall or slab between two buildings or two spaces to protect spread of smokes or fire vertically and horizontally.

FIRE TOWER	Refers to a stairway open or enclosed, detached and isolated from any building by a distance and can be approached from various floors of a building or buildings by connecting passage only.
FLOOR AREA, GROSS	The floor area within the inside perimeter of the outside or exterior walls of the building under consideration with no deduction for hallways, stairs, closets, thickness of interior walls, columns, or other features. Gross floor area of a building means summation of gross floor areas of all the floors of a building.
FLOOR AREA, NET	The floor area within the inside perimeter of the outside or exterior walls of the building under consideration with deduction for hallways, stairs, closets, thickness of interior walls, columns, or other features or spaces not used for human occupancy.
FOAM EXTINGUISHING SYSTEM	This system discharge foam to extinguish special fires.
HORIZONTAL EXIT	Crossing a fire barrier of a building or connecting building in the same level shall be treated as horizontal exit.
INTERIOR STAIRWAY	A designated area on ground or on water or on a portion of a building for helicopter landing or takeoff without servicing, repairing and refueling facilities.
INTERIOR STAIRWAY	A stairway within a building envelope.
PARTY WALL	A fire resistance rated wall where openings are protected, which is constructed from the ground level and continued up to at least 1m above the roof of a building to restrict the spread of a fire.
PUBLIC WAY	A Street, alley, or other similar parcel of land essentially open to the outside air deeded, dedicated, or otherwise permanently appropriated for building users or for public use or a single loaded corridor that is one lateral side opened to outer air, designed in such a way that there shall be no accumulation of smoke in case of fire. This corridor may be placed at any level of a building having a clear width and height of not less than 3 meter having guards and connected to the exit termination or refuge areas by exterior or enclosed stairs shall be treated as public way.

ROOF REFUGE AREA	When occupants are relocated at the flat roof of a building which are not connected with any means of exit shall be treated as isolated refuge area and must have provisions for placing of leaders of fire department excess vehicles.
SMOKE DETECTOR	A devise capable of sensing visible or invisible particles produced during combustion.
TRAVEL DISTANCE	Straight line distance between the remotest point of a space of a floor and the exit access door placed thereof.
TRAVEL PATH	Length of a passage from the remotest point of a space up to the exit access door placed thereof.
VENTILATION	Natural or mechanical intake of fresh air from outside and removal of inside air of an enclosed space.
VESTIBULE	A compartment provided with two or more doors with smoke lock system where the intended purpose is to prevent continuous and unobstructed passage by allowing the release of only one door at a time.
VENT, FIRE	A system which activates itself automatically or manually during a fire or can be activated manually to release the heat and smoke generated by the fire and smoke.
RAMP	A walking surface that has a slope steeper than 1 in 20 and accessible ramps are not steeper than 1 in 12.
WET-CHEMICAL EXTINGUISHING SYSTEM	A system where a solution of water and potassium carbonate and/or potassium acetate based chemical forms the extinguishing agent.
WET RISER STAND PIPE SYSTEM	A vertical pipe or consists of an array of pipes installed vertically in a building having landing valves with appropriate outlets at various levels of a building containing charged water at a specified pressure for fire extinguishing purposes.

1.3 General Requirements

The provisions of this Section shall specify the general requirements in respect of height and area limitations, open space requirements and access facilities for the fire service, which are to be provided for a building to protect it from potential fire hazards.

1.3.1 Height and Area Limitations

The height and area limitations of all buildings and structures shall be governed by the occupancy group classification, floor area ratio and type of construction, which are specified in Part 3 of this Code.

1.3.2 Open Space or Fire Separation Requirement

For the purpose of applying the provisions of open space or fire separation requirements of a building at its side, rear and frontages in Part 3 of this Code shall be followed.

1.3.3 Access Facilities for Fire Service

The access facilities for fire service vehicles and engines shall meet provisions provided in Part 3 of this Code.

1.4 Fire Drill

Fire drills based on fire order shall be arranged to train the occupants of a building in first-aid firefighting, relocation and orderly evacuation. The occupants shall be made thoroughly conversant with fire order, firefighting, and relocation and evacuation procedures in the event of an emergency. The guidelines of fire drill, relocation and evacuation procedure are given in Appendix A.

1.5 Fire Tests and Fire Resistance Rating

The fire resistance rating of individual building construction components shall be determined by standard materials testing procedure as detailed below.

- (a) The fire resistance ratings of building assemblies and structural elements shall be determined in accordance with ASCE 29 or ASTM E 119.
- (b) The construction materials which are intended to be classified as non-combustible shall be tested in accordance with ASTM E 136.
- (c) Flame resistance rating of all materials used for interior finish and trim shall be tested in accordance with ASTM E 84.
- (d) The fire door assemblies shall conform to the test requirements of ASTM E 152.

- (e) The fire windows and fire shutters shall meet the test requirements of ASTM E 163.
- (f) The fire resistances rating of structural elements are provided in Table 4.1.1. For details refer to ASCE 29.

Table 4.1.1: Fire Resistance of Structures

Concrete Aggregate Type	Minimum Equivalent Thickness of Concrete Walls, Floors, and Roofs for Fire Resistance Rating									
	1 hr		1.5 hr		2 hr		3 hr		4 hr	
	in	mm	in	mm	in	mm	in	mm	In	mm
Siliceous	3.5	89	4.3	109	5.0	127	6.2	157	7.0	178
Carbonate	3.2	81	4.0	102	4.6	117	5.7	145	6.6	168
Sand-light weight	2.7	69	3.3	84	3.8	97	4.6	117	5.4	137
Lightweight	2.5	64	3.1	79	3.6	91	4.4	112	5.1	130

Concrete Aggregate Type	Minimum Column Dimension for Fire Resistance Rating									
	1 hr		1.5 hr		2 hr		3 hr		4 hr	
	In	mm	in	mm	in	mm	in	mm	in	mm
Siliceous	8	203	9	229	10	254	12	305	14	356
Carbonate	8	203	9	229	10	254	11	279	12	305
Sand-light weight	8	203	8.5	216	9	229	10.5	267	12	305

Clay Masonry Unit	Minimum Required Equivalent Thickness of Masonry for Fire Resistance Rating													
	0.5 hr		0.75 hr		1 hr		1.5 hr		2 hr		3 hr		4 hr	
	in	mm	in	mm	in	mm	in	mm	in	mm	in	mm	in	mm
Brick of clay or shale, unfilled	1.7	43	2.0	51	2.3	58	2.85	72	3.4	86	4.3	109	5.0	127
Brick of clay or shale, grouted or filled with perlite, vermiculite, or expanded shale aggregate	2.3	58	2.65	67	3.0	76	3.7	94	4.4	112	5.5	140	6.6	168

1.6 Related Appendix

Appendix A Fire Drill and Evacuation Procedure

PART IV
Chapter 2
Precautionary Requirements

2.1 Occupancy Classification

All buildings shall be classified according to their use or by considering the character of their occupancy. For the purpose of this Code, the occupancy classification groups shall be as follows:

Occupancy A:	Residential
Occupancy B:	Educational
Occupancy C:	Institution for care
Occupancy D:	Health Care
Occupancy E:	Business
Occupancy F:	Mercantile
Occupancy G:	Industrial
Occupancy H:	Storage
Occupancy I:	Assembly
Occupancy J:	Hazardous
Occupancy K:	Garages
Occupancy L:	Utilities
Occupancy M:	Miscellaneous

The details of occupancy classification of buildings are provided in Part 3 of this Code.

2.2 Classification of Construction Types

For the purpose of this Code, every room or control area or space of a building or a building itself hereafter altered or erected shall be classified in one specific type of construction as grouped as follows:

GROUP I- Non-combustible, subdivided as follows:

Type- I A	4 hour protected
Type- I B	3 hour protected
Type- I C	2 hour protected
Type- I D	1 hour protected
Type- I E	Unprotected

GROUP II- Combustible, subdivided as follows:

Type- II A	Heavy timber
Type- II B	Protected wood joist
Type- II C	Unprotected wood joist
Type- II D	Protected wood frame
Type- II E	Unprotected wood frame

The types of construction are based on fire resistance of construction elements, which are detailed in Part 3 of this Code.

2.3 Fire Zones

The development areas of a city, township or municipality or union shall be divided into Fire zones as distinct areas based on the inherent fire hazards of the buildings to be constructed and the degree of safety desired for the occupancy group accommodated therein.

2.4 Mixed or Separated or Detached Occupancy

Where two or more occupancy types are amalgamated in a floor or in a building shall be designated as mixed occupancy shall be allowed as per provisions of A-Z list of Part 3 and this Code.

Where two or more occupancy types are in groups in a floor or in a building and separated as specified in the Table 3.2.1 of Part 3 and as per provisions of this Code shall be designated as separated Occupancy.

Hazardous occupancy J shall not be allowed as mixed or separated occupancy with any other occupancy classification as per provisions of this Code.

Building structures are isolated by fire separation distances as per provision of this Code shall be designated as detached occupancies.

2.5 Openings In Separation Wall

Opening means a hole or an aperture in the building envelope or in any wall within the building through which air can pass. Protective type opening means a hole or an aperture shall have open able closures with fire resistive assemblies to restrict air movement.

Separation wall not constructed monolithically or homogeneously and having joints shall be complied with requirements of smoke lock and fire resistance rating as per provisions of this Code.

Vertical solid elements which create a barrier within a space or create a building envelope shall be designated as wall or partitions as per provisions of this Code.

- (a) The openings in occupancy separation wall shall conform to the provisions set forth in the Part 3 of this Code.
- (b) Openings in fire separating walls and floors shall not exceed the approved limit and the opening shall be of protective type and conform to the approved provisions of this Code.
- (c) Fire separation walls shall not have opening exceeding 11.2 m² in area and the aggregate width of all openings at any floor level shall not exceed 25 percent of the length of the wall. When an entire storey floor area has fire separation walls on two opposite sides have openings shall be covered by automatic fire suppression system, the maximum allowable opening may be doubled with a minimum distance of 0.9 m between adjacent openings.
- (d) Each protected openings in a fire separation wall shall be limited to 5.6 m² in area with a maximum height of 2.75 m and width of 2.20 m. Wall or floor openings shall be protected with approved fire resisting means conforming to approve standards as per provision of this Code. When openings in floors have protected enclosures or have enclosure walls which form a shaft and have openings on enclosure wall shall be protected by fire assemblies.
- (e) Openings of service lines like cables, electrical wirings, telephone cables, plumbing fixture etc. shall be protected by enclosures having an approved fire resistance rating. Medium or low voltage electrical wire running through shaft or ducts shall be either armoured or cased within metal conduits as per provisions of Part 8 of this Code.
- (f) All openings in the fire separation walls shall be protected with fire resistance assemblies or automatic fire suppression system as per provisions of this Code.

2.6 Smoke and Heat Vents

Interior or indoor air qualities are maintained as good as natural outdoor air qualities as per provisions of this Code through openings in the building envelope shall be designated as Natural Ventilation.

Interior or indoor air qualities are maintained by the means of mechanical devices shall be designated as Mechanical Ventilation. Restricted ventilation means excessive smoke accumulation within a building during fire.

- (a) Smoke and heat vents shall be installed in areas of restricted ventilation such as windowless buildings, underground structures, and factories floor spaces of restricted ventilation.
- (b) Where exit access travel distance is more than 23 m, smoke and heat vents shall be constructed in accordance with the provisions of this Code.
- (c) The vent area and spacing of the vents shall comply with Table 4.2.1.
- (d) Closures of natural draft, smoke and heat vents shall be installed in such a way that fire service personnel can open it easily during a fire.
- (e) Smoke and heat vents on roof or ceiling or wall shall normally be kept open. In case of closed vents, automatic activation of the openings by heat responsive device rated at 38° C to 104° C above ambient shall be a requirement. The releasing mechanism shall be capable of opening the vent fully when the vent is exposed to a time-temperature gradient that reaches an air temperature of 260° C within 5 minutes. The vents shall also be capable of being opened by manual operation.
- (f) Fire Vents requirements for Industrial and Storage Buildings are given in Appendix B of Part 4.

Table 4.2.1: Smoke and Heat Vent Size and Spacing

Use group	Hazard Condition	Vent Area to Floor Area Ratio	Max Spacing of Vent Centres
Occupancy H1	Low Hazard	1:150	45 m
Occupancy H2	Moderate Hazard	1:100	36 m
Occupancy J1	High Hazard	1:30 to 1:50	22.5 m to 30 m
Occupancy J2, J3, J4	High Hazard	1:30 to 1:50	22.5 m to 30 m
Occupancy K1, K3	Low Hazard	1:150	45 m

2.7 Electrical, Gas and Hvac Services

The requirements of the electrical, HVAC and gas services shall meet the provisions of Part 8 of this Code.

- (a) Air-conditioning and ventilation systems shall be installed and maintained as per provisions of this Code so that the fire, fumes or smoke do not spread from one area of fire to other area of a building through the ducts or vents.
- (b) Properly designed fire dampers shall be installed within the air-conditioning and ventilation ducts, which shall automatically close the flow of air in case of fire.
- (c) For large assembly areas, department stores and hotels with more than 100 rooms in a single block, effective means for preventing circulation of smoke through the air-conditioning ducts shall be installed. Such means shall consist of approved smoke sensing control devices, where fuses of dampers may not function during early state of a fire due to insufficient heat as per provisions of this Code.

2.8 Surface Finishes

Materials used to trim or cover the interior and the exterior surfaces of a building have the potential of generating smoke and toxic fumes during a fire and have the potentiality of changing the nature of fire due to its ignitability as fuel. Use of such finish materials shall be classified as per provisions of this Code.

- (a) The fire susceptibility of various types of surface finishes shall be determined in terms of the rate of spread of fire (ASTM E 84). Based on the rate of spread of fire, the surface finish materials shall be classified into three (3) classes:

Class I	Surfaces of low flame spread: Flame does not effectively spread more than 300 mm in the first 1.5 minutes with an ultimate value of 600 mm.
Class II	Surfaces of medium flame spread: Flame does not spread effectively more than 300 mm and 850 mm in the first 1.5 minutes and 10 minutes respectively.
Class III	Surfaces of rapid flame spread: Flame spreads effectively more than 300 mm and 850 mm in the first 1.5 minutes and 10 minutes respectively.
- (b) Interior finish of walls and ceilings shall have a flame spread rating not greater than those in Table 4.2.2 for various occupancy classes.

Table 4.2.2: Acceptable Flame Spread Rating Classes of Interior Finish

Occupancy Class/Use Group		Vertical Exits and Passage Ways	Corridors Providing Exit Access	Rooms or Enclosed Areas
A1	Detached single family dwelling	III	III	III
A2	Two family dwelling	I	I	II
A3	Flats or Apartment	I	I	I
A5	Hotels and Lodging Housing	I	I	I
B	Educational	I	I	I
C1, C2	Institutional, Residential & custodial	I	I	III
C3	Institutional-Incapacitated	I	I	I
C4	Institutional- Restrained	I	I	I
D	Health Care	I	I	I
E	Business	I	II	II
F	Mercantile	I	II	II
G	Industrial	I	II	II
H	Storage	III	II	III
I1	Large assembly with fixed seats	I	I	I
I2	Small assembly with fixed seats	I	I	I
I3	Large assembly without fixed seats	I	I	I
I4	Small assembly without fixed seats	I	I	I
J	Hazardous	I	II	III

Note: Class III may be adopted Instead of Class II where the area is covered by automatic fire suppression system.

2.9 Glazing Assemblies

- (a) Buildings of construction shall use any one of the following types of glazing using wire glass by electro-copper or equivalent. Building of construction types as designated as unprotected or combustible may use hardwood sashes or frames or both.
- (b) Glazing system used partially or as a whole to fulfill fire separations or fire barriers requirements as per provisions of this Code shall be the equivalent of required fire resistance rating. Glazed doors, windows or partitions or wall with appropriate smoke lock along with other safety due to fragility, translucency or transparency shall be correctly installed. Such fire-resistant glazing assembly must function as an integral system together with the frame, beads, bead fixings, glazing materials and frame fixings all working together with compatibilities with the standards installation as per provisions of this Code.
- (c) Wired glass panels shall comply with the following requirements:
- Thickness of the glass shall not be less than 6 mm.
 - Embedded wire netting mesh in the glass shall not be more than 25 mm mesh.
 - The sashes or frames or both shall be entirely made up of iron or any other approved metal. The frame shall be securely fixed into the wall (except panels of internal doors).
 - Setting of the panels of glass shall be achieved by rebates or grooves of not less than 6 mm diameter/width or depth keeping due allowance for expansion. The glass shall be secured to the frame by hard metal fastenings. Approved sealants may be used for weather proofing.
 - Where wired glass panels are labelled as protective openings, they shall conform to the size limitations shown in the Table 4.2.3.

Table 4.2.3: Limitations of Wired Glass Panel sizes in Protective openings

Required Fire Resistance Rating	Opening Size		
	Max Height (m)	Max Width (m)	Max Area (m ²)
3 hours	NP	NP	NP
1½ hour door in exterior walls	NP	NP	NP
1½ hour fire rating	0.85	0.25	0.065
¾ hour fire rating	1.4	1.4	0.85
Fire windows	1.4	1.4	0.85

Note: Size limitations are not applicable for Fire Rated Glazing Assemblies.

NP = Not Permitted.

- (d) Electro-copper glazing shall comply with the following requirements:
- (i) Thickness of the glass shall not be less than 6 mm.
 - (ii) Not more than 0.4 m² of square glass shall be formed by electro-copper glazing in sectional lights.
 - (iii) The sashes or frames or both shall be entirely made up of iron or any other approved metal. The frame shall be securely bolted into the wall (except panels and internal doors).
 - (iv) Setting of the panels of glass shall be achieved by rebates or grooves of not less than 6 mm width or depth keeping due allowance for expansion. The glass shall be secured to the frame by hard metal fastenings. Approved sealants may be used for weather proofing.
- (e) Wall opening more than 5 m² shall not be deemed to be effectively protected by wired glass or electro-copper glazing.
- (f) Wired glass or electro-copper glazing not exceeding 0.85 m² in area shall be allowed provided it is cased in hard metal and secured to the frames by hard metal hinges not exceeding 60 mm apart and by fastening at top, centre and bottom.

2.10 Skylights

- (a) Wired glasses used in skylights shall comply with the following requirements:
- (i) Thickness of the glass shall not be less than 6 mm;
 - (ii) Wire netting mesh embedded in the glass shall not be more than 25 mm square;
 - (iii) The glazing shall be caged in frame of continuous metal divided by bars 750 mm apart centre to centre. The frame and bars shall be iron or other approved metal (or of hard wood covered with sheet metal). The glass shall be secured to the frame by hard metal fastenings. Approved sealants may be used for weather proofing.
- (b) Single opening for Skylight more than 5 m² shall not be deemed to be effectively protected by wired glass.

2.11 Fire Lifts

- (a) Fire lifts shall be installed as per provisions of this Code. Fire lifts, where installed shall be fully automated from the ground level with all though fire rated and protected wiring and switches and shall have a minimum capacity of 8 persons.
- (b) Fire lifts shall be operated and maintained by the inmates of building except during fire. During fire, Firemen shall takeover to operate such lifts.
- (c) Fire lifts shall be equipped with approved two way voice communication with the fire command station or control room or security room on the exit termination level of a building.
- (d) Number and location of fire lifts in a building shall be decided on the basis of total occupant load, floor area and compartment.
- (e) A Lift shaft or bank shall be dedicated to Fire lift.
- (f) The speed of the lift shall be such that it can reach the top floor from ground level (non-stop) within 1 minute.
- (g) Smoke detectors shall be installed at a distance of 3m from every entry doors of Fire Lifts and links with corresponding lift control panel to prevent lift doors to open in case of fire at any level.
- (h) All lifts in tall structure shall be operable during fire. There shall be provisions for firemen to take over the control of lift operation as per provision of this Code.
- (i) All stretcher and hospital lifts shall be operable during fire. There shall be provisions for firemen to take over the control of lift operation as per provision of this Code.
- (j) Lifts installed for accessibility shall be operable during fire. There shall be provisions for firemen to take over the control of lift operation as per provision of this Code.
- (k) Lift lobby shall be connected with at least one fire stair by a means of exit component.

2.12 Utilities (Occupancy L) and Exempted Quantities of Hazardous Material

Occupancy type L is a separated occupancy from the main occupancy classifications to provide ancillary electro-mechanical service facilities require a special attention which shall be taken as per provision of this Code. Utilities (Occupancy L) and exempted quantities of hazardous materials for different occupancies are given below:

2.12.1 Occupancy A: Residential

- (i) Flammable liquids used for domestic purposes shall be kept adequately sealed in approved containers within the limit of exempted quantity at all times.
- (ii) Stoves and heaters using open flame shall be so located at defined space with proper precaution.
- (iii) Exhaust fans used in kitchens shall be placed on a peripheral wall of the building or to a duct connected directly to outside and shall be made of non-combustible material. The duct shall not pass through combustible materials.
- (iv) Doors leading into a room containing flammable liquids shall be provided with self-closing devices. Appropriate signs identifying the storage materials and requesting the users to keep the door closed shall be marked on both sides of the door.
- (v) All outdoor roof top antennas shall be protected by proper lightning arrester.
- (vi) Rooms containing boiler shall be separated from the main building by appropriate separation wall with all its openings protected as per provisions detailed in Sec 2.3 of Part 3 and Sec 2.5 of this Chapter.
- (vii) Areas or rooms within the building identified as Control Area shall be protected or segregated by appropriate separation wall or by other approved means as per the provisions of this Code.

2.12.2 Occupancy B: Educational

- (i) Control areas containing volatile flammable liquids shall be separated from the adjoining areas in as per provisions of this Code.

- (ii) Gas pipeline entering any building shall be equipped with shutoff valves outside the building with conspicuous marking clearly delineating the location as per provisions of Part 8 of this Code.
- (iii) The openings of boiler rooms shall be adequately protected by fixed, automatic or self-closing fire assemblies.

2.12.3 Occupancy C: Institutional

Permit shall not be granted for storage or handling of any hazardous material even in control areas, except for normal use in amounts not exceeding the exempted amounts specified in Chapter 2 of Part 3, in a building or part thereof classified as Occupancy C.

2.12.4 Occupancy D: Health Care

Storage of volatile flammable liquids such as chloroform, ethyl alcohol, mentholated spirit etc. shall be stored in Control Areas and no unauthorized person shall be allowed to handle such liquids.

2.12.5 Occupancy E: Business

- (i) Exit aisles or approaches in self-service in a space shall not be obstructed by placing checkout stand with associated railings or barriers on its passage.
- (ii) All operations in open air markets, refuelling stations, road side stands for sale of farm products etc. shall be so conducted that unobstructed access to exits are always maintained.

2.12.6 Occupancy F: Mercantile

Provisions are same as those of Sec 2.12.5 (Occupancy E).

2.12.7 Occupancy G: Industrial

- (i) Apparatus are not capable to igniting flammable vapour shall be permitted within a control area of a building using or processing or storing volatile flammable liquid. Control Areas of a building using or processing or storing such flammable liquid shall be covered by exhaust ventilation system.
- (ii) Boiler rooms and areas containing heating plants shall be separated from the rest of the occupancy as per provisions of this Code.
- (iii) Adequate protective measures shall be taken against hazards associated with distribution and use of electricity and gas in accordance with the provisions of Chapters 2 and 8 of Part 8.
- (iv) The machine layout shall be congenial to safe fire practice.

2.12.8 Occupancy H: Storage

- (i) Apparatus are not capable to igniting flammable vapour shall be permitted within a Control area or part of a building using or storing volatile flammable liquid. Control Areas of a building using or storing such flammable liquid shall be covered by exhaust ventilation system.
- (ii) Boiler rooms and areas containing heating plants shall be effectively segregated from the main occupancy.
- (iii) Adequate protection shall be taken against hazards associated with distribution and use of electricity and gas in accordance with the provisions of Chapters 2 and 8 of Part 8.

2.12.9 Occupancy I: Assembly

- (i) All materials used for decorative purposes in buildings of Occupancy I shall be non-combustible. If fabrics and papers are used for decorative purposes, shall be treated with flame resistant chemicals/materials.
- (ii) Rooms and parts of a building containing high pressure boilers, refrigerating machinery, large transformer or other service equipment having explosion potential shall not be located on or adjacent to the defined exit route. Such rooms shall be effectively cut off from the rest of the building and connected to open air through approved ducts or openings.
- (iii) Rooms or parts of a building used for storage of combustible materials such as paints or other items shall be effectively cut off from main assembly building or protected by approved automatic sprinkler system. Such areas shall be away from staircases.
- (iv) Legitimate stages having such facilities as fly galleries, gridirons and rigging shall be covered by an automatic sprinkler system above and below such stage areas or spaces. Auxiliary spaces such as dressing rooms, store rooms, and workshops and the proscenium opening shall be effectively covered by fire resistant curtains capable of withstanding a lateral pressure of 4 kN/m². The curtain shall be equipped with self-closing emergency device and when closed shall be tight enough to prevent spread of smoke.
- (v) Legitimate stage roof above every theatre using movable scenery or motion picture screen constructed of highly combustible materials shall be fitted with ventilators in or above it. The ventilators shall be operable from the stage

floor manually or by fusible links or some approved automatic heat actuated device to give an opening to sky with an area of one-eighth the area of the stage.

- (vi) In theatres not protected by automatic fire sprinklers, the proscenium wall using movable scenery or decorations shall be provided with maximum of two openings to enter the stage and each opening shall not be of more than 2 m².
- (vii) Film projection apparatus shall be enclosed within fire resistant enclosures.
- (viii) Auditoriums of theatres and cinemas shall be installed with vents on roof having vent area equal to the floor area including balconies and galleries, boxes and tiers. Larger numbers of smaller vents shall be preferable over smaller number of larger vents.

2.12.10 Occupancy J: Hazardous

- (i) Equipment and machinery in operations, igniting and/or emitting combustible volatile substances shall be installed in a standard environment as recommended in NFPA or equivalent standards.
- (ii) Rooms containing boiler or heating plant shall be effectively separated from the main occupancy.

2.12.11 Occupancy K: Garage

As per safety requirement of NFPA or equivalent standard.

2.12.12 Occupancy L: Utility

As per safety requirement of NFPA or equivalent standard.

2.12.13 Occupancy M: Miscellaneous Buildings

As per safety requirement of NFPA or equivalent standard.

2.13 RELATED APPENDIX

Appendix B Fire Protection Considerations for Venting in Industrial and Storage Building.

PART IV
Chapter 3
Means of Egress

3.1 scope

The provisions of this Section shall control the design, construction and arrangement of building components to provide a reasonably safe means of egress. Any repair or alteration works within a building shall be prohibited unless the existing means of egress and fire protection system are continuously maintained or a continuous alternative exits and protection measures are taken to provide an equivalent degree of safety for the occupant and the workers for the total duration of such project.

3.2 Components of Means of Egress

3.2.1 A means of egress is an evacuation system with the provisions of reentry for rescuers and fire fighters where a continuous and unobstructed way of exit travel shall be provided from any point within a building to a designated area of refuge for allowable delayed evacuation and ended up with the exit termination by reaching a street abutting building or plot or an safe area which is open to air and designated assemblies for evacuees.

The way of exit travel within a building form any point thereof along a means of egress shall consist of three parts: (1) the exit access, (2) the exit, and (3) the exit discharge

- (a) A way or path of evacuation from any point of an area affected due to fire incident leads to a protected entry to another separated area of a building shall be termed as exit access. Straight line distance between the remotest point of an area of incident and the entrance point of a separated area shall be measured and termed as a travel distance.
- (b) The exit is a component or a group of components start with a protected opening to evacuate an area of fire incidence and provides a safe entry to a separated area which is component of means of egress and subsequently leads to the exit discharge.
- (c) The outer edges or peripheral points of a building from where occupants shall evacuate the building envelope termed as Exit discharges which shall lead evacuees to the terminal points at a safe distance from thereof.

An area or any plot abutting street which is open to air and designated for systematic assemblies of evacuees to complete the process of egress system shall be termed as exit termination.

3.2.2 The parts of the means of egress consist of any of the following exit components:

- (a) A doorway, separated or refuge area like smoke and fire proof enclosure, compartment, corridor, passage, ramp, balcony, an exterior or open or interior fire stair, or any combination of these, leads orderly to the exit discharge which offer safety from fire or smoke from the area of incidence.
- (b) Horizontal exit shall provide a delayed egress by relocating the occupants from their initial location due to a fire incident to a separated area at same level of a same building or at the same level of adjoining or detached buildings connected through a fire door or a vestibule or a passage or corridors for relocation of evacuees. Receiving areas are capable to accommodate expected evacuees for certain time period, free from heat, smoke and aggressive fire, from the area of incidence and shall lead to exit discharges without returning the evacuees to their initial locations.

3.2.3 Generally lifts, escalators and moving walks shall not be regarded as components of means of egress. When they are designed and installed for safe operation during fire shall be included as components of means of egress.

3.2.4 Means of Escape: A way out of a building or structure that does not conform to the formation of means of egress but does provide a safe way out.

3.3 General Requirements

3.3.1 Design considerations or assumptions:

- (a) Fire initiated from only one source in single space shall aggravate within a building or adjacent structures over a time period.
- (b) More than one space or source of fire at the same time shall not be considered.
- (c) All Construction Materials by qualities and quantities including surface finish, utilities, fabrications of movables and immovable, stored materials shall be approved types as per provisions of this Code.
- (d) Stability of structural elements or building itself shall be as per provisions of this Code.
- (e) Occupants, Rescuers and fire fighters life safety shall be the prime consideration thus egress system including relocation and fight in place or evacuation and reentry provisions shall be as per provisions of this Code.

- (f) Fire suppression and extinguishment arrangement for life safety and minimize property damages shall be performance based as per provisions of this Code.
- (g) Provisions of this Part shall be the minimum standard, in excess of these provisions shall not be prevented to design a egress system or to install advance and higher standard of detection and extinguishment equipment or both which shall be approved by the authorities having jurisdiction.

3.3.2 All buildings constructed for human occupancy or control areas or storages shall be provided with adequate exit facilities to permit safe and quick unaided egress of the occupants in the event of fire or other emergency.

3.3.3 Exits shall not be used for any other purpose at any time that would obstruct the intended use of those components during emergency.

3.3.4 Where corridors or passages are components of exits shall not be designed or used as components to supply or return air.

3.3.5 Preferences of levels of walking surfaces in the means of egress shall be more than 1 in 20. Ramps or stairway shall be used in case of changes in elevations of walking surfaces.

- (a) Abrupt changes not exceeding 130 mm but exceeding 60 mm shall be beveled 1 in 2.
- (b) Changes in elevation exceeding 130 mm shall be considered as a change in level.
- (c) A stairway in walking surface of the means of egress shall consist of minimum two steps and all of them shall be identical and shall have tread depth not less than 330 mm and height of risers shall not be exceeded more than 230 mm but shall comply tread and riser combination as per provision of this Code.
- (d) Changes in levels 530 mm or more in walking surfaces of the means of egress shall be achieved either by a ramp or by a stairway.
- (e) Presence and location of such steps or ramps in the walkways shall be readily apparent.
- (f) Other than ramp, a slope of walking surfaces along the direction of travel shall not be steeper than 1 in 20 and slope perpendicular to the travel direction shall not be exceeded 1 in 48.
- (g) Slope of ramps shall be complied with the accessibility where required as per provisions of this Code.

3.3.6 From the exit access all exits shall be clearly visible. Corridors and passages leading to the exit discharge shall be marked and signposted to guide the evacuees as per provisions of this Code. A space used in darkness having more than one exits shall be illuminated exits sign as per provision of this Code.

3.3.7 The owner or lessee of all new and existing buildings shall be responsible to provide the safety provisions for all occupants and rescuers and firefighters. If in any existing building, the exit facilities are deemed inadequate in view of the requirements of this Code, the authority having jurisdiction may order to comply with the provisions of this Code.

3.4 General Provisions of Exits

3.4.1 All exits shall be easily discernible and accessible from the areas served by them.

3.4.2 Exit from any room or space shall not open into an adjoining or intervening room or area except where such adjoining room or area is an accessory to the area served, is not a hazardous occupancy. If hazardous or a control area, provide a direct exit to the outside of a building envelope or directly connect with the components of egress system.

3.4.3 No portion of Exits shall pass through a room that may be subject to lock with detachable key or be intervened by a door that may have detachable key operated lock and the door is locked when the building is occupied.

3.4.4 All entry points to the assembly occupancy shall serve as Exits and shall have the total capacity for at least one-half of the total occupant load. Provisions of exits other than entries shall have capacity to evacuate at least two-thirds of occupant from each level of assembly occupancy.

3.4.5 All exits shall be so located and arranged that they shall provide continuous and unobstructed means of egress up to the exit discharge.

3.5 Occupant Load

Total occupant load means summation of all occupants of only one level at the pick hour occupancy where maximum occupants are present.

Occupant load shall be considered as per provisions of this Code to design each and every component of means of egress system shall be termed as design occupant load.

3.5.1 Design Occupant Load

The design occupant load for which the component of means of egress is to be provided shall be the highest number computed as per the provisions of (a), (b) and (c) as stated below:

- (a) The actual number of occupants for whom the area served by the exits is designed;
- (b) Number of occupants shall be computed as prescribed in Table 4.3.1.
- (c) The number of occupants in any area shall be computed as per provisions of (a) or (b) as stated above and in all cases the higher value shall govern the design.
- (d) The computation of design occupant load shall be the summation of occupants of a space and the evacuees of other spaces whose are using the said space as for waiting or passing through in case of emergency to gain an access to a component of means of egress.

Table 4.3.1: Occupant Load Factor

Occupancy		Unit of Floor Area in m ² per Occupant*
A	Residential	18 gross
B	Educational:	
	Class room	2 net
	Preschool	3.5 net
C	Institutional	12 gross
D	Health Care:	
	In patient areas	15 gross
	Out-patient areas	10 gross
I	Assembly:	
	with fixed seats	Number of seats designed.
	with movable seats	0.93 net
	standing space only	0.37 net
	with table and chairs	1.5 net
	Passengers that can be unloaded simultaneously to a terminal or a platform	0.15 net
E	Business: Office Space	3 gross

Occupancy		Unit of Floor Area in m ² per Occupant*
F	Mercantile:	
	Retail sales Area, Ground floor or Basement	2.3 net
	All other floor	4.6 net
G	Industrial	10 gross
H	Storage	20 net
K	Garages and open parking structures	23 net
L	Utility	Actual occupant load
M	Miscellaneous Building	Actual occupant load

* As per Sec 3.5.1(b) of this Chapter, design occupant load shall be calculated and any fraction shall be rounded to next higher integer value. Width of all components of egress system shall satisfy requirements of specified in the Table 4.3.2

3.5.2 Fixed Seats

The occupant load for an assembly or educational area having fixed seats shall be determined by the seating capacity of the area. For fixed seats without dividing arms, the capacity shall be taken as one person for every 500 mm of seat.

3.5.3 Maximum Occupant Load

The design occupant load, need not to be calculated more than one person per 0.3 m² of usable floor space.

3.5.4 Mezzanine Floors

The occupants of a mezzanine floor evacuating through other floors the occupant load shall be added to the receiving floors.

3.5.5 Roofs

A Roof, an open air space used as assembly or refuge area, educational or other types of human occupancy shall be provided with exit facilities as per provisions of this Code.

3.6 Capacity of Exit Components

3.6.1 The capacity of egress components shall be complied with the occupant load of the area served. The required width of each component shall be computed on the basis of the allotted width per occupant prescribed in Table 4.3.2, subject to the minimum widths of such components specified in Sections 3.7 to 3.12 and the travel distances of such components as per provision of this Code.

Table 4.3.2: Required Width per Occupant

Occupancy		Buildings without Sprinkler System (mm per person)			Buildings thoroughly Sprinkled (mm per person)		
		Stairways	Ramps & Corridors	Doors	Stairways	Ramps & Corridors	Doors
A	Residential						
B	Educational						
E	Business						
F1, F2	Mercantile	8	5	4	5	4	4
G	Industrial						
H	Storage						
C1, C2	Institutional	8	5	4	5	5	4
C3, C4, C5	Institutional	10	5	4	8	5	4
D	Health Care	25	18	10	15	12	10
I	Assembly						
F3	Mercantile	10	7	5	7	5	5
J	Hazardous	8	5	4	8	5	4
K, L, M		8	5	4	5	4	4

Note: width of the components of egress shall be divided by value specified in this table to determine the maximum allowable occupant load served by them.

3.7 Corridors and Passageways

3.7.1 Occupants commencing exit travel along a corridor or a passageway shall be lead to an exit discharge. Length of dead end corridors and passageways and branches thereof shall not be exceeded as per Sec 3.15.4 of this Chapter.

3.7.2 The required width of corridors and passageways shall be calculated on the basis of the occupant load in accordance with the provisions of this Code and shall not be less than as per Sec 3.15.4 of this Chapter.

3.7.3 The minimum ceiling height of the corridors and passageways used as a means of egress shall not be less than 2.4 m.

3.7.4 All exit corridors or passages shall have a fire resistance rating of 1 hour or more as per provisions of this Code.

3.7.5 Protective opening leads to an exit shall be fire doors or fire windows or a fire assembly having a fire resistance rating of at least 20 minutes or more as per provisions of this Code.

- (a) Certified Fire resistance rating of Doors shall be in accordance with ASTM E152 without the hose stream test.
- (b) Fire resistance rating of the fire door assembly has to perform as required 20, 30, 60, 90, 180 minutes or more shall be leveled A, B, C, D, E and F respectively.
- (c) Fire door assembly of any approved materials shall qualify through ASTM E152 without the hose stream test.

3.8 Assembly Seating and Waiting

- (a) Assembly buildings primarily meant for theatrical, operatic performances or cinematic projection shall have the seats securely fastened to the floor with exceptions as permitted in this Code. All seats in balconies and galleries shall be securely fastened to the floor except boxes with level floor and less than 14 seats.
- (b) Seats not fixed to the floor shall be permitted in restaurants and such other places provided that 1.25 m² of floor space is allotted for every seat excluding dancing floor and stage. Adequate aisles shall be maintained at all times to reach exits without obstruction when such occupancies are in use.

3.8.1 Assembly buildings which contain seats, tables, equipment or exhibitions or displays shall be provided with aisles, free of obstructions, leading to the exit.

3.8.2 Minimum clear widths of steeped aisles and other means of egress serving assembly seating shall be calculated on the basis of number of seats and in accordance with Table 4.3.3. Interpolation shall be permitted between the specific values shown thereof. The minimum clear width of steeped aisles as found by above calculation shall be modified in accordance with the conditions stated below:

- (i) If risers exceed 178 mm in height for steeped aisles the width of the steeped aisles as shown in the table shall be multiplied by factor a ,

$$\text{Where, } a = 1 + \frac{\text{Riser Height} - 178}{125} \quad (4.3.1)$$

- (ii) In the Table 4.3.3 values of steeped aisles not having a handrail within a 760 mm horizontal distance shall be 25 percent wider.
- (iii) In Table 4.3.3 values of width of ramps used for ascending and steeper than 1 in 10 slope shall be increased by 10 percent.

Table 4.3.3: Capacity Factors for Assembly Seating

Number of seats within a single assembly space.	Clear Width per Seat Served	
	Steeped aisles (mm)	Passageways, Ramps and Doorways(mm)
≤ 2,000	7.6 <i>a</i>	5.6
5,000	5.1 <i>a</i>	3.8
10,000	3.3 <i>a</i>	2.5
15,000	2.4 <i>a</i>	1.8
20,000	1.9 <i>a</i>	1.4
≥25,000	1.5 <i>a</i>	1.1

3.8.3 The minimum width of level or ramped aisles shall be as specified below:

Seats on both sides of the aisle 1.0 m

Seats on one side of the aisle 0.9 m

3.8.4 The minimum width of stepped aisles shall be as specified below:

Seats on both sides of the aisle 1.2 m

Seats on one side of the aisle 1.0 m

3.8.5 The minimum clear gap between rows, measured as the clear horizontal distance between the back of the row ahead and the nearest projection of the row behind shall be 300 mm. For chairs having automatic or self-rising seats, the measurement shall be made with the seats in the raised position, for non-automatic seats the measurement shall be taken with the seats in the down position.

3.8.6 For rows of seating served by an aisle or doorway at only one end of the row, the path of travel shall not exceed 10 m from any seat to the aisle or doorway. The minimum clear gap between rows shall be increased beyond 300 mm specified in Sec 3.8.6 by 15 mm for each seat in excess of 7, but the clear gap need not exceed 550 mm.

3.8.7 In any assembly occupancy spectators are allowed to wait in the lobby or similar space within the building until seats are available. Exits shall be provided for the waiting spaces on the basis of 0.28 m² areas per person waiting space and one wheel chair space for every 100 occupant. Such waiting occupant load shall be added with main assembly load for calculating exit size for the assembly as per provisions of this Code.

3.9 Doorways

One surface of a door leaf which is exposed to a fire incident is the terminal point of exit access and other surface of that said door which is unexposed to that fire incident is the starting point of an exit. A door or an opening protective assembly is an obstruction for occupants to pass through from exit accesses to exits until and unless it is installed as per provisions of this Code.

3.9.1 Each occupant of a room or space shall have access to at least one exit door or exit access assembly. The occupant load per exit door and the travel distance up to that door shall not exceed the values specified in Table 4.3.4.

3.9.2 Where either the occupant load or the travel distance exceeds the values specified in Table 4.3.4 shall have multiple exit doors to comply the both.

3.9.3 The width of a door shall not be less than 1 m and the height shall be not less than 2 m. Exit doors shall be side swing or pivoted of side hinge type.

3.9.4 No sliding or hanging door shall be used as a means of exit. In pressurized areas and when occupant load is less than 10, restriction of Sec 3.9.3 may be exempted.

3.9.5 All exit access doors shall be of a side-swinging type. When the occupant load exceeds 50 or in a hazardous occupancy, the doors shall swing outward from the room or towards the direction of travel. Swinging of the door shall not constrict the width of the corridor narrower than 0.9 m measured at the most critical position.

3.9.6 Exit doorways shall not open directly on a flight of stairway. A clear area which more than the width of the door leaf as specified in the above Sec 3.9.5 shall be maintained immediately outside the doorway. The floor levels shall be same in the direction of travel as per provisions of this Code.

Table 4.3.4: Maximum Occupant Load and Travel Distance for Spaces with One Exit Door

	Occupancy	Maximum Design Occupant Load	Maximum Travel Distance (m)
A	Residential	12	23
C	Institutional		
D	Health Care		
B	Educational	50	23
I	Assembly		
E	Business		
F	Mercantile		
G	Industrial		
H	Storage	30	30
J	Hazardous	5	8

3.9.7 Revolving doors shall not be used as a means of exit in assembly, educational or institutional buildings or in spaces with an occupant load of 200 or more. In all other cases revolving doors shall not constitute more than half of the total required exit door width and each revolving door with least diameter of 2.7 m shall be credited not more than 50 persons. Exit doors shall be installed in the same wall within proximity of 3m of Revolving doors and shall comply with the following:

3.9.7.1 Revolving doors shall be positioned with a dispersal area at a distance of 3m or more from the foot or top of stairway or escalators or moving walks or lift lobbies.

3.9.7.2 Revolving doors shall stop rotating and stand still in a book-fold position at a force not more than 800 N or when a force is applied not more than 578 N to a wing within 760 mm of outer edge or due to sudden power failure catch automatically released and ready to manual reevaluation and that provide a path which shall have aggregate width minimum 910 mm.

3.9.7.3 A manual control switch shall be installed in an approved location.

3.9.7.4 Speed of revolving door shall not exceed the revolution per minute shown below:

Speed of Revolving Door		
Inside Diameter (m)	Manual-mode Speed limit (rpm)	Power-mode Speed limit (rpm)
2	12	11
2.1	11	10
2.3	11	9
2.4	10	9
2.6	9	8
2.7	9	8
2.9	8	7
3	8	7

3.9.7.5 All exit doors shall be operable without the using a detachable key from the side they serve to evacuate.

3.10 Stairways

Change in level in elevations achieved by steps combination of identical risers and treads as per provisions of this Code shall be termed as Stairway irrespective of their locations. Stairways within an envelope shall be termed as Staircase. Exception: stepped aisles with in an assembly.

Width of Stairways shall be a length perpendicular to the direction of travel, a clear distance measured between inner edges of handrails or a clear distance between inner edges of a handrail of exposed side to its opposite and parallel surface measured at a height of inner edge of cross section of that handrail. In case of variation in width measurement the smallest value shall represent the width of a stairway. Required combination of dimensions for risers and treads given in Table 4.3.5.

Required guards and handrails shall continue for the full length of each flight of stairways. Inner turns of handrail of flights shall be at the landings and grasp ability of handrails shall be smooth and continuous, Handrail Brackets or balusters attached to the bottom surface of handrail shall not be considered to be obstructions to grasp ability. Gap between any surface and handrail shall be not less than 63.5 mm.

Stairways serving more than three storey building having capacity more than 10 occupants shall have visual enclosures to avoid any impediments to stair use by persons having fear of height, any arrangement intended to meet this requirement shall be at least 1070 mm in height.

3.10.1 The required width of exit stairways shall be computed in accordance with the provisions of Sec 3.6, but it shall not be less than the minimum widths specified in Tables 4.3.6 and 4.3.7

3.10.2 The least dimension of landings or platforms in exit stairways shall not be less than the required width of stairway and shall be leveled, except that the landing between two stair flights in a straight run shall not be required to be wider than 1.2 m in the direction of travel.

When two stair flights are not straight or nonparallel to each other, a turning in the path of travel direction occurred which is other than U turn. Landing width shall be the required width of stairway and length of the common landing between such flights shall be one tread depth more lengthen when measured from both edges of stairway from both the flights.

Table 4.3.5: Combination of Risers and Treads

Gradients			Step Dimensions		Available Headroom Clearance of Flight	Handrail or Guard Height	Maximum Number of Flights
Grade	Angle of Flight		Tread Depths	Risers			
(%)	Deg	(mins)	(mm)	(mm)	(mm)	(mm)	
31.25	17	21	406	127	2159	851	6
33.87	18	43	394	133	2184		
37.28	20	27	375	140			
41.07	22	20	356	146			
44.44	23	58	343	152	2210	838	Unlimited
48.07	25	40	330	159	2235		
53.06	27	57	311	165			
57.44	29	52	324	171	2261		
63.63	32	28	279	178	2286		
69.04	34	37	267	184	2311		
75	36	52	254	190	2362		
81.57	39	12	241	197	2388		
88.88	41	38	229	203	2438		
97.05	44	9	216	210	2464		
103.02	45	51	210	216	2489	864	10
107.07	46	57	206	222	2515		
112.5	48	22	203	229	2515		

Note: Allowable length of nosing at the outer edge of tread shall not be included in the tread depth measurement. The maximum rise of a single flight between landings shall not be exceeded 3658 mm and in case of large assembly maximum rise of a single flight between landings shall not be exceeded 2438 mm.

Table 4.3.6: Minimum Width of Stairways in Egress System

Occupancy		Minimum Width of Each Stairway (mm)
A	Residential: A1, A2 A3, A4, A5	As per Table 4.3.6 1120
B	Educational Occupant load up to 130 Occupant load more than 130 but not more 250	1120 2235
D	Hospital Patient area Staff area	2235 1120
I	Assembly: I1, I2, I3, I4, I5	As per provisions of this Code.
	All others	As per provisions of this Code.

Note: The required number of stairways shall be determined by dividing the calculated total widths of stairways as per sections 3.5, 3.6 and Table 4.3.2 of this Chapter by applicable minimum stair width as specified in this table and any fractions thereof shall be rounded up with the next higher integer. Unit width of stair and multiple even numbers shall be maintained as per provisions this Code.

Table 4.3.7: Fire Escape Stairs

Element	Serving More than 10 Occupants	Serving 10 or Fewer Occupants
Clear widths	560 mm between handrails	
Minimum horizontal dimension of any landing or platform	560 mm	
Maximum riser height	230 mm	
Minimum tread, exclusive of nosing	250 mm	
Tread construction	Solid, 13 mm diameter perforation permitted	
Winders	Not permitted	permitted subject to Sec 3.10.7

Element	Serving More than 10 Occupants	Serving 10 or Fewer Occupants
Spiral	Not permitted	permitted subject to Sec 3.10.7
Maximum height between landings	3.70 m	
Headroom, minimum	2.00 m	
Access to protected openings	Door or casement windows, 600 mm x 2000 mm or double-hung windows 70 mm x 900 mm clear opening	Window providing a clear opening of at least 500 mm in width, 600 mm in height, and 0.53 m ² in area
Level of access openings	Not over 300 mm above floor; steps if higher	
Discharge to ground	Swinging stair section permitted if approved by authority having jurisdiction	
Capacity, number of person	13 mm per person if access by door; 25 mm per person if access by climbing over window sill	10

Note: The maximum design occupant load for a Fire escape stair shall not be exceeded 50 occupants from any floor level.

3.10.3 The rise and tread dimensions in a stairway shall be identical and the headroom requirements shall conform to the provisions of this Code.

3.10.4 Handrails height on stair shall be not less than 860 mm and not more than 960 mm above the surface of the tread, measured vertically from the top of the rail to the outer edge of the tread. Peripheral diameter of circular cross section of a handrail shall not be less than 32 mm and not more than 50 mm. Any other shape with perimeter dimension of not less than 100 mm, but not more than 160 mm and with the largest cross-sectional dimension not more than 55 mm shall be permitted provided that all edges are rounded to provide a radius of not less than 3 mm. Handrails shall be graspable along their entire length. Additional handrails that are lower or higher than main shall be permitted.

3.10.5 The height of guards shall not be less than 105 mm measured vertically from the top of the guards from the surface of adjacent area to be served by them. When balusters are used in the guards rail shall be used to create a pattern as such size that a sphere 100 mm in diameter shall not pass through any opening up to a height of 860 mm. Riser, tread and the bottom rail of guards formed a triangular opening shall not be of such size that a sphere 150 mm in diameter shall not pass through.

3.10.6 There shall be no variation in excess of 5 mm in depth of adjacent treads or in the height of adjacent risers, and the tolerance between the largest and smallest tread or between the largest and smallest riser is 10 mm in any flight.

3.10.7 Monumental stairs, Circular stairs, Curved stairs, Spirals and winders, stepped and rung ladders, alternate tread devices shall be permitted as per provisions of this Code.

3.10.7.1 When the width of stairways exceeded 4475 mm termed as Monumental or Grand Stairway shall be permitted as per provisions of this Code.

3.10.7.2 Curved stairs or circular stairs shall be permitted as a component of means of egress as per provisions of this Code provided that the depth of tread is not less than 280 mm at a point 300 mm from the narrower end of the tread and the smallest radius is not less than twice of stair widths and shall comply with the provisions of this Code.

3.10.7.3 Spiral stairways shall be permitted where occupant load shall not more than five. For spiral stairways the following conditions shall be applicable:

- (a) The clear width of the stairs shall not be less than 660 mm.
- (b) The height of risers shall not exceed 240 mm.
- (c) Headroom shall be not less than 1980 mm.
- (d) Treads shall have a depth not less than 190 mm at a point 300 mm from the narrower edge.
- (e) All treads shall be identical.

3.10.7.4 Winders shall be permitted in stairs where occupant load shall not be more than three.

- (a) Winders shall have a tread depth not less than 150 mm and a tread depth not less than 280 mm at a point 300 mm from the narrowest edge.
- (b) The clear width of the stairs shall not be less than 660 mm.

3.10.7.5 Stepped ladders and Rung ladders shall be installed with pitch that exceeds 75 degrees as per standards of ANSI A14.3. The lowest rung of any ladder shall not be more than 300 mm above the level of the surface beneath it.

- (a) From towers and elevated platforms around machinery or similar spaces subject to occupancy load not to exceed three persons.
- (b) Open structure, observation towers or railroad signals that are designed for occupancy not more than three persons.

3.10.7.6 Alternate tread device

The occupant load shall not exceed three and shall comply with the followings:

- (a) Handrail shall be provided on both sides of alternate tread device having clear width not less than 430 mm and not more than 610 mm
- (c) Headroom shall not less than 2000 mm and angle of the device shall be between 50 degrees and 68 degrees to horizontal.
- (c) The initial tread of the device shall begin at the same elevation as the platform, landing, or floor surfaces and the alternating treads shall not be laterally separated by a distance more than 50 mm.
- (d) Treads shall have projected depth not less than 150 mm and each tread providing 240 mm of depth, including overlapping of treads.
- (e) The height of the risers shall not exceed 240 mm.

3.10.8 Stairways shall have continuous guards on both side along the direction of travel and a continuous handrail shall be provided with inner edge guard. A stair of width more than 1120 mm but not more than 2235 mm shall have guards and handrails on both of the edges. Inner edge handrails shall be continuous and outer edge handrails shall be along the flights extended up to one tread depth on both the landings. A stair the width exceeds 2235 mm; intermediate handrails shall be installed with similar length of outer edge handrail. Single traffic lane shall be calculated 560 mm in the stairway and two traffic lanes shall be 1120 mm. Widths of stairs shall be multiple of two traffic lane other than width specified in the Table 4.3.6.

3.10.9 All exit stairways shall be constructed by materials that conform to the fire resistance requirements of the type of construction of the building, except that solid wooden handrails shall be permitted for all types of construction.

3.10.10 An exit stairway shall not be built around a lift shaft unless both of them are located in a smoke proof enclosure and made of a material with fire resistance rating required for the type of construction of smoke proof enclosure.

3.10.11 Exterior stairways used as fire stair shall not be considered as a component of means of egress, unless they lead directly to the ground or a refuge area, are separated from the building interior by fire resistive assemblies or walls and are constructed by noncombustible materials and free from smoke accumulation.

3.11 Ramps

3.11.1 Ramp is a sloping surface steeper than 1 in 20 but not steeper than 1 in 8 used by walkers only. Slope of ramps to comply with accessibility requirement shall not be steeper than 1 in 12.

3.11.2 The minimum width of exit ramps shall not be less than that width required for corridors or passages.

3.11.3 The slope of an exit ramp shall not exceed 1 in 8, but for slopes steeper than 1 in 10 the ramp shall be surfaced with approved non-slip material or finished such as to effectively prevent slipping.

3.11.4 Guards and handrails shall be provided on both sides of ramps having slope steeper than 1 in 15.

3.11.5 Ramps shall be straight, in case of changes in the travel direction that shall be made at the level platforms or at the landings except that ramps having a slope steeper than 1 in 12 may be curved at any place.

3.11.6 Length of the sloping portion of ramps shall be at least 915 mm but not more than 9150 mm long between level platforms or landings.

3.11.7 Level platforms or landings shall be at least as wide as the ramps and shall be placed at the bottom, at intermediate levels where required, and at the top of all ramps. Level platform shall be provided on each side of openings into or from ramps having minimum length of 915 mm in the direction of travel and when a door swings on the minimum length of platform or landing shall be 1525 mm.

3.11.8 Doors on ramps shall not be opened on sloping surface shall be complied with the requirements of 3.9 of this Chapter.

3.11.9 Sloping or ramp driveway approaching basements or any parking structures shall not be credited as an exit ramp when slope is steeper than 1 in 8 and not complied with Sec 3.11 of this Chapter. Exits requirement of such basements shall be achieved by stairways or fire lifts within smoke proof enclosure approached by a two doors smoke lock vestibule.

3.12 Horizontal Exits

3.12.1 The connection between two separated areas of a building or connection between buildings at same level which the horizontal exit serves shall be provided with at least 2 hour fire resistance rated walls, or by an open air balcony or a bridge having protected openings.

3.12.2 The horizontal exits shall be protected from the area of incidence by self-closing fire door.

3.12.3 The width of a horizontal exit access door shall not be less than 1 m.

3.12.4 Changes in level in the elevation along the direction of the horizontal exit shall not be achieved by single step but by ramps which is not steeper than 1 in 12.

3.12.5 Where the horizontal exit serves for only one side, fire door shall swing in along the direction of travel. When horizontal exit serves both the side of separated area, the doors shall have two leaves and each leave dedicated to satisfy direction of travel from assigned area, or there shall be two independent doors assigned for two areas each of them serves only one area. When the building is occupied the doors installed in horizontal exit shall be operable at all times without the use of a detachable key.

3.12.6 Horizontal exit relocates occupants to an area which is either a public space or a space used by other occupants and shall be termed as a refuge area. The capacity of the refuge area shall be computed on the basis of net floor area excluding stairways, shafts and spaces allotted to occupants of the receiving end. The required capacity of a refuge area shall be 0.28 m² per healthy occupant and 0.3 m² per wheelchair or 2.8 m² per patients retained in bed for delayed egress or an area equivalent to a passage or a corridor having width to comply the capacity of evacuees and connected with the components of exits up to exit discharge.

3.13 Smoke Proof Enclosure

Any compartment or a room or a control area surrounded by barrier walls within a building structure shall be protected from smoke penetration during a fire incident occurred elsewhere in the building shall be termed as smoke proof enclosure.

A stairway with in an envelope shall be termed as Interior stairway or staircase. Any exterior side having opening of 50 percent or more in such a way that there shall be no smoke accumulation shall be termed as open stair.

3.13.1 An interior stairway conforming to Sec 3.10 and having entry from an exterior balcony or through a ventilated vestibule conform a smoke proof enclosure provided no direct opening or any aperture allowed on the walls of the stair from the building side.

3.13.2 All exit stairways mentioned above shall be protected by a smoke proof enclosure when serving occupants are located in a high rise building.

3.13.3 There shall be provision to access enclosed stairways through vestibule or an open balcony. The minimum width of a vestibule shall be equal to width of connected passages or corridors specified in section 3.7 in this Chapter and the minimum length of a vestibule in the direction of travel shall be 1.8 m.

3.13.4 The minimum fire resistance rating of the walls forming a smoke proof enclosure around stairway including the vestibule thereof shall be 4 hours and separated from the area of incidence having no openings other than a fire door for the entry to the vestibule. For fire rating of the door see Chapter 1 Part 3.

3.13.5 All doors in smoke proof enclosure and the vestibule shall be self-closing type or they shall be fitted with automatic closing devices actuated by the fire detection system.

3.13.6 The vestibule shall have adequate natural ventilation. Each vestibule shall have a minimum area of openings of 2 m² divided into two in an exterior wall facing a courtyard, street or public way wider than 6 m. The location of one opening measuring 1.5 m² shall be as high as possible and another shall be 0.5 m² as low as possible.

3.13.7 If the enclosed staircase is windowless, mechanical ventilation shall be installed. If the vestibule is windowless, mechanical ventilation shall also be installed. In addition to ventilation a positive pressure of 50 Pa shall be maintained in the vestibule. This positive pressure must be developed within 30 seconds of the incident of fire. When the staircase and the vestibule are windowless emergency illumination shall be provided.

3.14 Number of Exits

3.14.1 The number of exits shall be determined as per provisions of Sec 3.6, Tables 4.3.1, 4.3.2 and 4.3.8 of this Chapter and complying with maximum dead end passage or corridors and maximum travel distance.

3.14.2 Total required widths of exits shall be calculated as per provisions of the Tables 4.3.2 and 4.3.8 shall be divided and distributed at a distance not less than one-third of diagonal distance of space and the travel distance and the width of each exit shall comply with the provisions of this Code. The required number of exits in a space as specified below:

Occupant load less than 50	Minimum 1 exit
Occupant load 50 to 500	Minimum 2 exits
Occupant load 501 to 1000	Minimum 3 exits
Occupant load more than 1000	Minimum 4 exits

3.14.3 High rise buildings having a floor area larger than 500 m² on each floor used as educational, institutional, assembly, industrial, storage or a mixed occupancy involving any of these or hazardous occupancy, shall have a minimum of two staircases. These staircases shall comply with the requirements as specified in Sec 3.13 of this Chapter.

3.14.4 Where two accessible means of egress are required, the exits serving such means of egress shall be located at a distance from one another not less than one-half the length of the maximum overall diagonal dimension of the building or area to be served.

3.15 Travel Path

3.15.1 Travel path shall be measured along the center line of a natural and unobstructed path up to center of an exit access door opening. In case of a stairway exist in the travel path shall be measured along an inclined straight line through the center of outer edge of each tread of a stairway.

3.15.2 Occupant load and components of exits shall be arranged in such a manner that the travel path from any point in the area served shall not be exceeded as listed in the Table 4.3.8.

3.15.3 Unit width shall be 560 mm and fraction of unit width less than 280 mm shall not be credited. Where calculation of total required width give fractional result, next larger integral number of exit units or integral number plus one-half shall be used. Where changes in elevation exist, one-half or less unit of width shall not be permitted.

3.15.4 Capacity of exits shall be measured in unit of width of 560 mm and the number of occupants per unit width shall be determined by the occupancy group and type of exits as listed in Table 4.3.8.

3.15.5 Wherever more than one exit required in a room or in any floor they shall be placed as remote as possible from each other. As far as practicable, exits shall be arranged in such a manner to provide a refuge area or an exit discharge to the occupants irrespective of the direction of travel from any point in an area served.

3.16 Means of Exit Signs and Illumination

3.16.1 All required means of exit or exit access in buildings or areas requiring more than one exit shall be signposted. The signs shall be clearly visible at all times, where necessary supplemented by directional signs. All exit doors shall be clearly marked for easy identification.

Exceptions: Building Occupancy type A.

3.16.1.1 Location: Exit signs shall be installed at stair enclosure doors, horizontal exits and other required exits from the storey. When two or more exits are required from a room or area, exit signs shall be installed to clearly indicate the direction of egress.

Exceptions:

- (i) Main exterior exit doors which obviously and clearly are identifiable as exits need not be signed when approved by the Building Official.
- (ii) Exit signs are not required for buildings of occupancies A1, A2 and individual units of A3.
- (iii) No sign is needed for exits from rooms or areas with an occupant load of less than 50 for Occupancy type C.

Table 4.3.8: Determination of Exit and Access Requirements.

Occupancy Group/ Classification		Maximum Travel Path (meter)		Capacity Number of Occupancy per unit width of the component				Ramp, Passage, Corridors	
		Unsprinklered	Full fire resistive or sprinklered	Door openings		Stairs, Escalators	Ramp, Corridors, Exit passageways, Horizontal exit	Minimum width (mm)	Maximum Dead End (mm)
				To outdoors at Grade	All other Exit and corridor doors				
A1, A2	Residential	N.R.	N.R.	N.R.	N.R.	N.R.	N.R.	N.R.	N.R.
A3,		45	60	50	40	30	50	36	12190
A4,A5		45	60	50	40	30	50	36	12190
B	Educational	45	60	100	80	60	100	915	12190
C1, C2	Institutional	38	53	50	40	30	50	915	12190
C3, C4, C5		38	53	30	30	15	30	2440	9150
D	Health	38	53	30	30	15	30	2440	9150
E	Business	60	90	100	80	60	100	1120	15240
F	Mercantile	45	60	100	80	60	100	915	15240
G1	Industrial	60	120	100	80	60	100	1120	15240
G2		60	120	100	80	60	100	1120	15240
H1	Storage	30	53	75	60	45	75	915	15240
H2		38	45	75	60	45	75	915	15240
I	Assembly	45	60	100	80	60	100	1675	9150
J	High Hazard	15	45	50	40	30	50	915	N.P.

Notes:

1. In Hazardous occupancy (occupancy J) Travel Path should be performance based but shall not exceed 15240 mm.
 2. N.P. = Not permitted
 3. N.R. = No requirement, (except as provided in Table 4.3.5b)
 4. Capacity of ramp shall be reduced by twenty five percent when slope is steeper than 1 in 10.
 5. Corridors serving classroom area of an educational building. Other corridors shall have a minimum width of 1120 mm.
 6. Applies to corridors to patient area. Staff corridors shall have a minimum width of 1120 mm.
-

3.16.1.2 Graphics: The color and design of lettering, arrows and other symbols on exit signs shall be in high contrast with their background as per NFPA 170. Words on the signs shall be at least 150 mm high with a stroke of not less than 20 mm. For vernacular alphabet and numeric height shall be at least 150 mm with stroke not less than 20 mm.

3.16.1.3 Illumination: Signs shall be internally or externally illuminated by two electric lamps or shall be of self-luminous type. When the luminance on the face of an exit sign is from an external source, it shall have an intensity of not less than 53.8 lux from either lamp. Internally illuminated signs shall provide equivalent luminance.

3.16.1.4 Source of Power: Supply of power to one of the lamps for exit signs shall be provided by the premises wiring system. Power to the other lamp shall be from an on-site generator set which shall be installed in accordance with the provisions of this Code.

3.16.1.5 Floor-level Exit Signs: For floor-level exit signs additional approved low-level exit signs which are externally or internally illuminated, or self-luminous, shall be provided in all interior exit corridors serving guest rooms of hotels in Occupancy A5. The bottom of the sign shall be 150 mm to 200 mm above the floor level. For exit doors, the sign shall be on the door or adjacent to the door with the closest edge of the sign within 100 mm of the door frame.

3.16.2 Amusement Building Exit Marking: Approved exit direction marking and exit signs shall be provided. Approved low-level exit signs and directional marking shall be located not more than 200 mm above parallel the walking surface and at the exit path.

3.16.3 All exit signs shall be illuminated while in use at night, or during dark periods within the area served, in accordance with the provisions of this Code.

3.16.4 The means of exit and exit access in buildings requiring more than one exit shall be equipped with artificial lighting. The lighting facilities shall satisfy the provisions of this Code.

PART IV
Chapter 4
Equipment and In-Built Facilities Standards

4.1 Scope

The provisions of this chapter shall control standards of the design, installation and maintenance of equipment and in-built fixed, localized, portable facilities required for firefighting within a building and its premises. The regulations of this chapter shall be applicable for all buildings and the provisions stated herein shall not cover the firefighting requirements outside the building premises.

4.1.1 Extinguishing agents can be water, dry sand, ash, inert gas, dry chemical, and wet chemicals or mixed in nature of approved type. Agents will be selected as per the area have to extinguished.

4.1.2 The gaseous system shall be only used where water or foam cannot be used for fire extinguishing because of the special nature of the contents within the building or areas to be protected.

4.1.3 Fixed type fire protection system means there shall be a pipe circuit to cover full or part of a building and extinguishing agents supplied from a point. Localized fixed system means the system will cover a confined space with a self-extinguishing device fitted with a container ready to discharge automaticity. Portable type means the extinguishers can be hand carried in the site of incidents.

4.1.4 Fire Classification

Fire class A: Fire involving common combustibles such as wood, paper, plastics, clothes etc.

Fire class B: Fire involving flammable liquids and gases, such as gasoline, propane, and solvents.

Fire class C: Fire involving live electrical equipment such as computer, fax machine etc.

Fire class D: Fire involving combustible metals such as magnesium, lithium, aluminum etc.

Fire class K: Fire involving cooking media such as cooking oils and fats.

4.2 Fixed Type Fire Hydrant System

General area of application shall be Fire class A. Fixed type fire hydrant system comprises of, stand pipes and hose or reel pipes, sprinklers, drenchers or similar devices in appropriate combinations of these and capable of discharging water in an area which to be extinguish.

4.2.1 Water Quantity for Fire Protection

The required flow rate and duration of water for sprinkler or stand pipe system use within the building according to their occupancy classification shall be in accordance with Table 4.4.1 and size of pipes shall be as per provisions of this Code or on the basis of the hydraulic design of the system to maintain flow rate and duration of water discharge.

4.2.2 Water Sources for Fire Protection

Flow rate and duration of discharging water required for interior fire extinguishment of a building shall be supplied from one or any combination of the following sources.

Table 4.4.1: Fire Protection Flow Requirements*

Building Type**	Sprinkler System (litre/min.)	Standpipe and Hose System (litre/min.)	Duration in Minutes for Building Heights		
			Up to 51 m	51 m to 102 m	Above 102 m
Light hazard- I	1000	1000	30	38	45
Light hazard- II	1900	1900	50	62	75
Ordinary hazard- I	2650	1900	75	95	112
Ordinary hazard-II	3200	1900	75	95	112
Ordinary hazard-III	4800	1900	75	95	112

Notes:

* See also Sec 4.2.2.3.

** Values will be for one riser serving floor area of 1000 m².

Light hazard-I	:	Occupancy groups, A1, A2, A3, E1
Light hazard-II	:	Occupancy groups, A4, A5, B, C, D,E2, E3, I2, I4, F1
Ordinary hazard-I	:	Occupancy groups, I1, I3, I5, F2, F3, G1
Ordinary hazard- II	:	Occupancy groups, G2 , H1
Ordinary hazard- III	:	Occupancy groups, H2
Extra hazard	:	Occupancy group J-pressure and flow requirement for this group shall be determined by Fire Department but shall not be less than required value for Ordinary hazard- III

4.2.2.1 Direct connection to water main

For continuous water supply (public water supply system or private system) with sufficient quantity and pressure to feed and discharge firefighting equipment during peak demand period, direct connection of firefighting system to the water main may be adopted, Figure 4.4.1. In this case guidelines specified in NFPA 22 are to be followed.

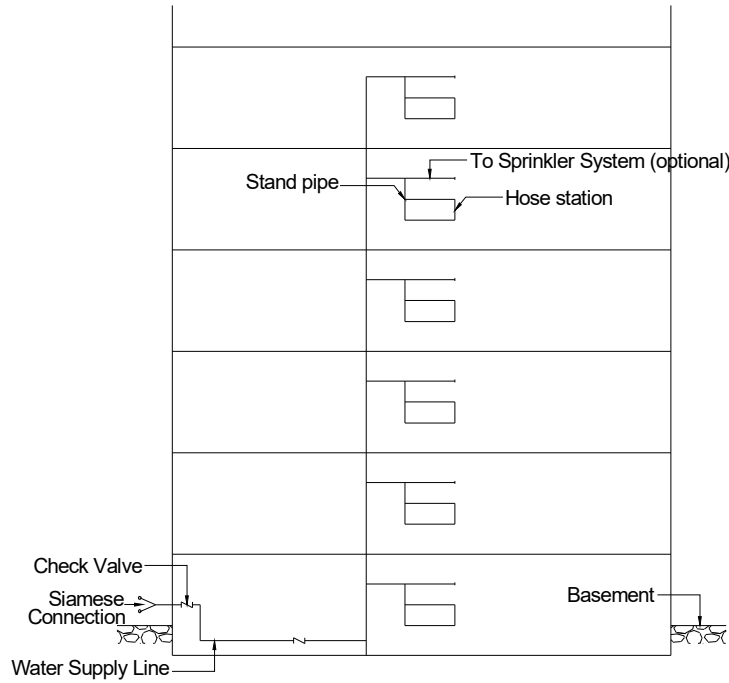


Figure 4.4.1 Typical diagram for standpipe and hose system connected directly to the water main

4.2.2.2 Roof gravity tanks

Any elevated structure holding a water reservoir or water tank or in any level within a building and having downward supply pipelines shall be termed as gravity tank only when a water reservoir located on a roof of a building shall be termed as roof gravity tank.

For water supply system with inadequate quantity or pressure during peak demand period but with sufficient pressure to feed roof tank, a roof gravity tank may be provided. In that case any one of the following steps shall be followed.

- (a) If only the static height of the roof gravity tank is used to feed and discharge the firefighting equipment, the height of the roof gravity tank from the top floor must be sufficient to create minimum required pressure at the top floor hydrant point. The minimum pressure at hose outlet for standpipes supplying a 50 mm or larger hose shall be at least 300 kPa. This minimum pressure for standpipe system supplying first aid hose (38 mm nominal) shall be at least 200 kPa. This minimum pressure for combination of sprinkler and hose pipe system shall be 600 kPa. To maintain the above required pressure the vertical distance of the roof gravity tank from the top floor hydrant point shall be at 31 m, 20.5 m and 62 m respectively, Figure 4.4.2.
- (b) If the vertical distance between the roof gravity tank and the top floor hydrant point cannot be maintained for gaining required pressure and discharge, fire pump of required size and number shall be installed with standard manufacturer recommended suction and delivery connections, Figures 4.4.3 and 4.4.4

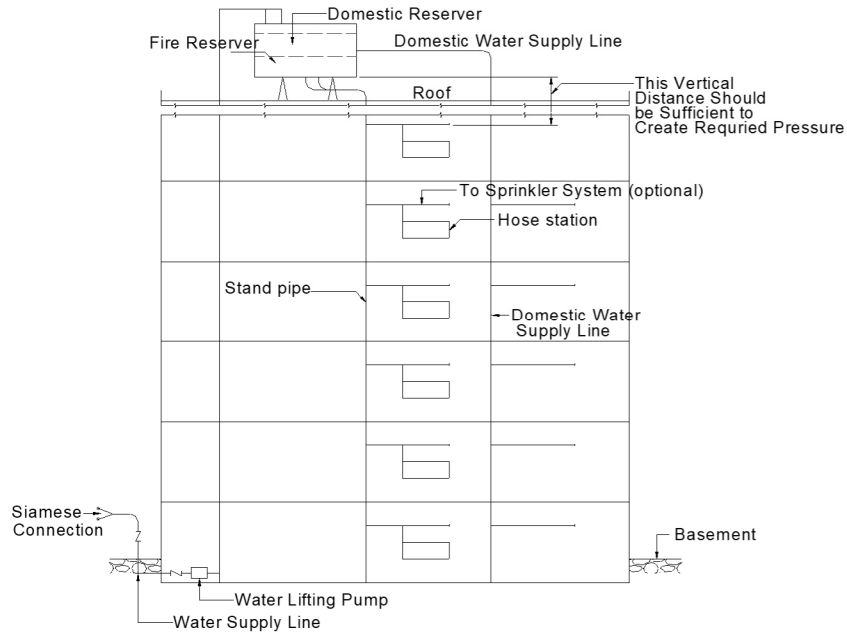


Figure 4.4.2 Typical diagram showing required static head of gravity roof tank with adequate domestic and fire reserve

4.2.2.3 Storage tank

In absence of public water supply system, the building premises shall have individual water sources specified in Part 8. For water supply system, to feed and discharge by firefighting equipment, the building premises may have deep tube well with required flow, water wells, natural water sources or a ground (or underground) tank, roof top tank, swimming pools etc. The capacity of these facilities shall be sufficient to satisfy the flow requirement as specify in Table 4.4.1.

4.2.2.4 Water supply test

After installation of the hydrant system, a flow test shall be conducted to verify the capacity of the discharge system such that the installation can fulfill the minimum capacity (flow and time) as specified in Table 4.4.1. This system shall be periodically inspected, maintained and tested in accordance with NFPA 25.

4.2.2.5 Fire pump

The firefighting equipment shall be directly feed by automatic main fire pump. Centrifugal pump, turbine-type pump (submerged or with vertical shaft) or positive displacement pumps with adequate supply pressure and flow capacity shall be used for water supply during demand. Centrifugal pumps shall not be used where a static suction lift is required.

Once the pump starts, it shall run continuously until stopped manually. The pump shall be fully operational within 30 seconds after starting. There shall be provision for manual starting where priming is necessary. Automatic priming equipment is necessary to ensure priming at all times. The fire pump shall not be used for other purpose.

Fire pumps shall have the rated capacities as shown in Table 4.4.2. The pump shall be rated at net pressure of 272 kPa or more as per requirement of the firefighting system demand. For pump installation procedure and fittings NFPA 20 shall be followed.

The pump shall be housed in a readily accessible position in a building of non-combustible construction. The pump shall be adequately protected against mechanical damage.

There shall be a provision for secondary fire pump which can be operated by a dedicated diesel engine or by an alternate power supply source with adequate control system and

incompliance with safety operation during fire. Quality of the pump assembly shall comply with the specification of International Association of Fire.

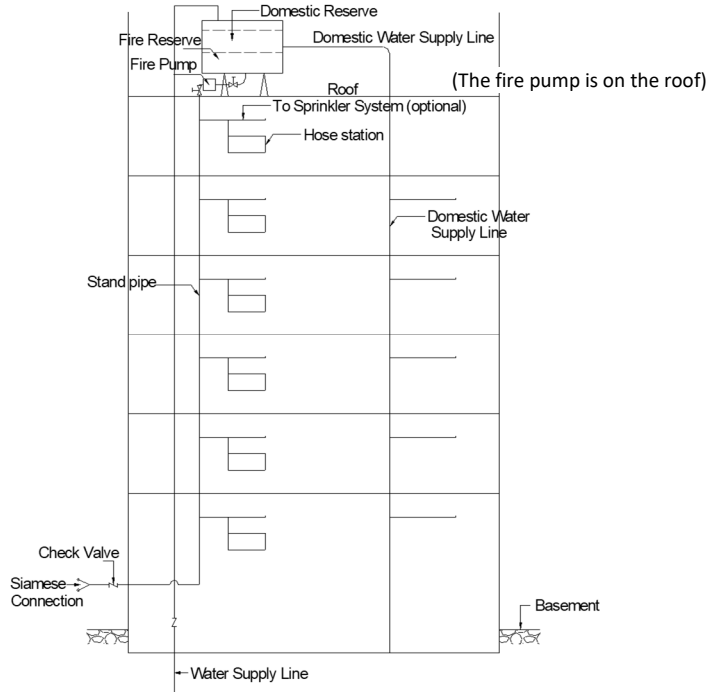


Figure 4.4.3 Typical diagram for gravity roof tank with adequate domestic and fire reserve.

4.2.3 Design Considerations for Standpipe and Hose System

4.2.3.1 The fire protection system shall be designed for their effective use either by amateur or trained firefighting personnel or both.

4.2.3.2 All standpipes in standpipe system shall be sized so that they will provide a minimum flow specified in Table 4.4.1. In standpipe system with more than one standpipe, the supply piping shall be sized for the minimum flow specified in Table 4.4.1 for the first standpipe plus 1000 litre per minute for each additional standpipe.

The total number of such additional standpipes shall not be more than 8. All standpipe risers shall be interconnected through check valves of equivalent size to prevent recirculation.

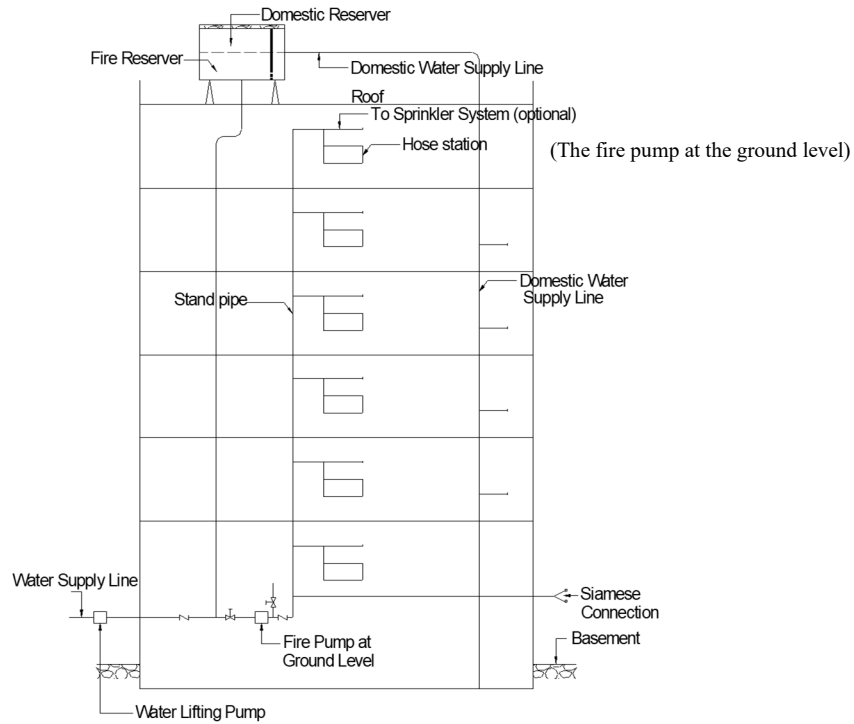


Figure 4.4.4 Typical diagram for gravity roof tank with adequate domestic and fire reserve.

4.2.3.3 The minimum pressure for standpipes supplying a 50 mm or larger diameter hose shall be at least 300 kPa. For standpipe supplying first aid hose (38 mm nominal diameter) may have a minimum pressure of 200 kPa. The maximum pressure at any point of the system shall not exceed 2434 kPa, if the hose connection at 40 mm diameter outlet exceeds 700 kPa approved pressure regulating device shall be installed to maintain the above maximum limits.

4.2.3.4 Diameter of the standpipe termed as size shall comply with flow and capacity requirement of the pump shown in Table 4.4.2 or hydraulically design to provide required flow and pressure at the topmost hydrant point.

Table 4.4.2: Fire Pump Data

Pump Rating litre/min (gpm) Discharge,	Minimum Pipe Sizes (Nominal) mm (inch)
946 (250)	75 (3)
1136 (300)	100 (4)
1514 (400)	100 (4)
1703 (450)	125 (5)
1892 (500)	125 (5)
2839 (750)	150 (6)
3785 (1000)	150 (6)
4731 (1250)	200 (8)
5677 (1500)	200 (8)

4.2.3.5 The water supply required for combined system (for partial automatic sprinkler and Fire Department hose) shall be calculated in accordance with Table 4.4.1 plus an amount equal to the hydraulically calculated sprinkler demand.

4.2.3.6 The system for firefighting purpose may be designed with automatic fire pump with water tank at the ground as shown in Figure 4.4.5.

4.2.3.7 The water stored in storage tank for firefighting operation shall not be used for other purposes. Accordingly, separate water connections should be provided as shown in Figure 4.4.6.

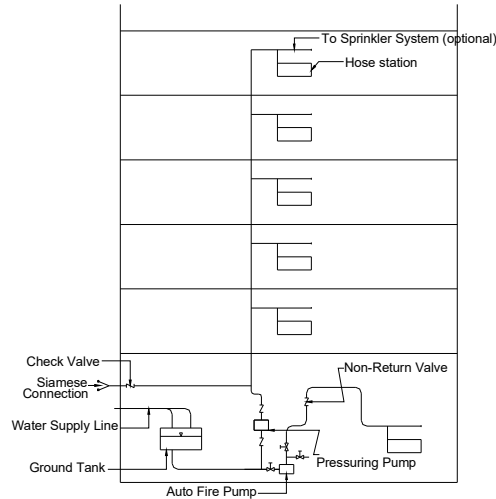


Figure 4.4.5 Typical diagram for fire protection with ground tank and automatic fire pump

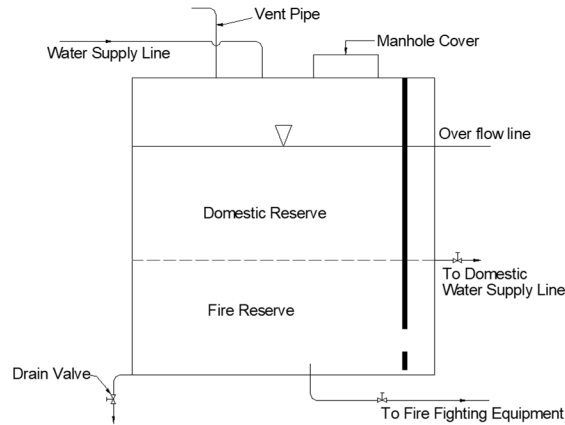


Figure 4.4.6 Typical diagram for storage tank (ground or overhead) with domestic and fire reserve.

4.2.3.8 The ground storage tank shall be easily accessible to fire engine of Fire Department. In absence of space available for fire engine, the cover slab of ground storage tank shall be designed to withstand a vehicular load of local fire engine.

4.2.3.9 The standpipe shall be located such as intermediate stair landing, vestibules or nearby in noncombustible enclosure such that it will be able to provide hose stream to the most remote area of the floor served.

4.2.3.10 The hose shall be connected to the standpipe within a height not more than 1.5 m from the finished floor level. The hose stations shall be easily accessible for inspection and testing.

4.2.3.11 The hose connection to a standpipe for large stream shall be at least 100 mm nominal and that of small stream may be 63 mm or 50 mm on each point. The size of first aid hose shall be 38 mm nominal. The hose length shall not be more than 30 m.

4.2.3.12 Different piping materials and fittings for standpipe system presented in Tables 4.4.3 and 4.4.4 shall conform to the standard or one of the standards cited against them. The standard requirements for other materials not provided in these tables shall be subject to the approval of the Authority.

Table 4.4.3: Piping for Standpipe System

Material	Standard
Copper Tube	ASTM B75, ASTM B88
Copper and Copper-Alloy Tube	ASTM B251
Steel Pipe	ASTM A55, ASTM A120, ASTM A135
Wrought Steel or Iron	ANSI B36.10

Table 4.4.4: Standpipe Fittings

Material	Standard
Cast Iron	ANSI 616.1, ANSI B16.4
Copper	ANSI B16.18, ANSI B16.22
Malleable Iron	ANSI B16.3
Steel	ANSI B16.5, ANSI B16.9, ANSI B16.11, ANSI B16.25, ASTM A234

4.2.3.13 The standpipe riser shall be supported at the top and at the lowest level. The riser shall also be provided with support at the alternate level in between top and bottom level of the standpipe riser. The support shall be of adequate strength to support the water-filled pipe load and an additional load of 110 kg.

4.2.3.14 The horizontal standpipe shall have hangers with a spacing not more than 5 m. The hanger shall be able to carry a load of five times the weight of the water-filled pipe and an additional load of 110 kg.

4.2.3.15 There shall be Siamese connection also termed as firemen connection to the standpipe or to the delivery pipe of the gravity roof storage tank. The location of Siamese connection shall be easily accessible from the street or means of access.

4.2.3.16 The system shall be provided with adequate drainage piping to discharge under pressure. The drain pipe shall not discharge into sanitary sewer.

4.2.3.17 All control valves shall be designed to withstand the pressure specified in Sec 4.2.3.3

4.2.4 Wet Riser

A wet riser is a vertical pipe of not less than 100 mm internal diameter, kept permanently charged with water which is then immediately available for use on any floor in the building at which a hydrant or landing valve is provided. The riser is connected to a booster pump or town main of suitable capacity so that they are capable to supply four 13 mm jet at 2.5 bars at the highest outlets.

4.2.5 Down Comer

A similar function to that of wet riser is performed by down comer which like a wet riser is constructed of vertical piping, with outlets at different levels, but is supplied with water from a tank in the roof through terrace pump, gate valve and non-return valve. It is also fitted with inlet connections at ground level and air release valve at roof level for being capable of charged with water by pumping from fire engines.

4.2.6 High Velocity Water Spraying Projector System

This system applies water in the form of conical spray consisting of droplets of water traveling at high velocity. The three principles of extinguishments are employed, namely emulsification, cooling and dilution. While the water droplets are passing through the flame zone, some of the water is turned into steam, diluting the oxygen feeding the fire. Addition of water to the burning oil also cools it and reduces the rate of vaporization. In addition to this droplets of water traveling at high velocity bombard the surface of the oil to form an emulsion of oil and water that will not support combustion.

4.2.7 Water Mist Technology

Fine water spray suppression system can extinguish fires using water and nitrogen from air. Nozzle is used to atomize water by nitrogen or other suitable media to generate mist or fog of finely controlled water droplets. The system operates at low pressure and produces droplets in a range of 80 to 200 microns. These droplets extinguish fire rapidly and efficiently even those involving highly volatile hydrocarbons. This system is an alternative to Halon and other gaseous system in many applications.

4.2.8 Drenchers

Drenchers are used for the external protection of the building against exposure hazard, or radiant heat. Drencher heads are similar to sprinkler heads and may be sealed or unsealed. Drenchers are of three types, roof drenchers, wall drenchers, window drenchers.

4.2.9 Dry Riser System

Dry riser stand pipe system shall be an equivalent alternative of wet riser stand pipe system. The water supply for an automatic or semi-automatic standpipe system shall be designed such that the system must be capable of supply the system during peak demand hour.

4.2.10 Design Consideration of Sprinkler System

4.2.10.1 A system of water pipes fitted with sprinkler heads as per manufacturers specification may be installed actuate automatically, control and extinguish a fire by the discharge of water.

4.2.10.2 The pipe schedule sizing to supply different number of sprinklers for their different uses may be in accordance with Tables 4.4.5 and 4.4.6

4.2.10.3 Each sprinkler shall serve a maximum ceiling area specified in Table 4.4.7 for different types of building according to their uses.

4.2.10.4 Water supply piping and fittings for sprinkler system shall conform to the standard or one of the standards cited against them in accordance with Tables 4.4.4 and 4.4.8. The standard requirements for other pipe materials not provided in these tables shall be subject to the approval of the Authority.

4.2.10.5 The sprinkler system shall be provided with adequate support or made flexible to prevent pipe breakage during earthquake.

4.2.10.6 The hanger in sprinkler system shall be designed to carry a load equal to five times the weight of the water-filled pipe plus an addition load of 110 kg. The support shall be designed to support a load equal to the weight-filled pipe plus and additional load of 110 kg.

4.2.11 Connection

4.2.11.1 There shall be Siamese connection to the sprinkler system located outside the building and accessible to the fire department connection.

4.2.11.2 All risers shall be connected through a gate valve with a main of size equal to that largest riser.

4.2.11.3 The sprinkler system shall be provided with adequate drainage arrangement. The drain pipe shall not discharge into sanitary sewer.

4.2.11.4 All control valves and fittings shall be able to withstand the pressure specified in Sec 4.2.3.3.

4.2.12 Inspection, Testing and Maintenance

4.2.12.1 Inspection

All piping and equipment shall be inspected for satisfactory supports in accordance with Sec 6.15 in Part 8 of this Code and protection from damage and corrosion. All outlets shall be free from obstruction.

Table 4.4.5: Size of Water Supply Steel Pipe to Sprinklers

Pipe Size mm (inch) nominal	No. of Sprinkler for Light Hazard*	No. of Sprinkler for Ordinary Hazard *	No. of Sprinkler for Ordinary Extra Hazard *
25(1)	2	2	1
32(1 $\frac{1}{4}$)	3	3	2
38(1 $\frac{1}{2}$)	5	5	5
50(2)	10	10	8
63(1 $\frac{1}{2}$)	30	20	15
75(3)	60	40	27
88(3 $\frac{1}{2}$)	100	65	40
100(4)	NL**	100	55
125(5)	-	160	90
150(6)	-	275	150
200(8)	-	400***	225***

- * Definitions of these terms are given in Table 4.4.1.
 ** No limit.
 *** One sprinkler system riser or combined system riser shall serve the floor area not more than 4850 m² for light and ordinary hazardous occupancy and 2325 m² for extra hazardous occupancy

Table 4.4.6: Size of Water Supply Copper Pipe to Sprinklers

Pipe Size mm (inch) nominal	No. of Sprinkler Connection for Light Hazard*	No. of Sprinkler Connection Ordinary Hazard *	No. of Sprinkler Connection Ordinary Extra Hazard *
25(1)	2	2	1
32(1¼)	3	3	2
38(1½)	5	5	5
50(2)	12	12	8
63(1½)	40	25	20
75(3)	65	45	30
88(3½)	115	75	45
100(4)	NL**	115	65
125(5)	-	180	100
150(6)	-	300	170
200(8)	-	***	***

- * Definition of these terms is given in Table 4.4.1.
 ** No limit.
 *** One sprinkler system riser or combined system riser shall serve the floor area not more than 4850 m² for light and ordinary hazard occupancy and 2325 m² for extra hazard occupancy

Table 4.4.7: Ceiling Area for a Sprinkler

Construction Type	Light Hazard		Ordinary Hazard		Extra Hazard	
	Protected area	Spacing (Max)	Protected area	Spacing (Max)	Protected area	Spacing (Max)
	ft ² (m ²)	ft (m)	ft ² (m ²)	ft (m)	ft ² (m ²)	ft (m)
Roof or Floor on Trusses, Girders or Beam With High Piling ***	200 (18.6)	15 (4.6)	130 (12.1)	15 (4.6)	100 (9.3)	12 (3.7)
Open Wood Joists With High Piling ***	225 (20.9)	15 (4.6)	130 (12.1)	15 (4.6)	100 (9.3)	12 (3.7)
Other Type of Construction With High Piling ***	168 (15.6)	15 (4.6)	130 (12.1)	15 (4.6)	100 (9.3)	12 (3.7)

-
- * Maximum distance in m between sprinklers and between line of piping.
- ** The definitions of these terms are given in Table 4.4.1.
- ** * Storage facilities which permit closely piled materials over 4.5 m or materials on rack over 3.6 m.
-

Table 4.4.8: Piping for Sprinkler System

Material	Standard
Copper and Copper-Alloy	ASTM B32, ASTM B75, ASTM B88, ASTM B25, ANSI B36
Steel	ASTM A53, ASTM A120, ASTM A135, ASTM A795

4.2.12.2 Testing

Fire protection plumbing system or part thereof shall be tested and approved after installation by the Authority.

- (a) Testing of Standpipe System: The hydrant pipes shall be hydraulically tested to a pressure 1400 kPa or 150% of working pressure whichever is the higher for 2 hours without any leakage at any points. The system shall be able to maintain above test pressures. The system shall also be tested for the required flow at the highest outlet.
- (b) Testing of Sprinkler System: This system shall be tested for at least 2 hours for a pressure of 1000 kPa or at 350 kPa in excess of normal working pressure when normal working pressure will be more than 650 kPa. The system shall be able to maintain above test pressures. The system shall also be tested for the required flow at the highest outlet.
- (c) Testing of Sprinkler System Pump: The pump used for sprinkler system firefighting purpose shall be tested by approved authority for their performance characteristics and this test report must be submitted at the time of supply of pump. The pump shall be retested or repaired to its original condition if their performance characteristics fall below more than 10 percent of the supplier's test characteristic curve or as specified for the fire protection water supply system.

4.2.12.3 Maintenance

The system shall be maintained for safe operating conditions and tested at least once a year.

4.3 Fixed Installation Other Than Water

Other than water there are different types of fixed installation. These are of mainly two types. (a) Centrally fixed, (b) locally fixed.

4.3.1 Centrally Fixed Installation Discharging Extinguishing Agent other than Water

4.3.1.1 General

This installation can be of two types, one for zone coverage and the other for total coverage. For these system pipe circuits and exhaust manifold are required and shall have special discharging Alarm distinctly different than fire alarm. These fixed installations can be of different types, such as (a) Foam installation, (b) Vaporizing liquid installation, (c) Dry powder installation. (d) Gaseous installation (e) Dry chemical installation (f) Wet chemical installation.

4.3.1.2 Foam installation

Foam extinguishing system shall be of an approved type and shall be installed in accordance with the specification of the manufacturer. The foam extinguishing system is designed to discharge fire suppressive foam concentrates over the area to be protected.

- (a) There are different types of foam installation, such as (i) Pump operated mechanical foam installation, (ii) Self-contained pressurized installation, (iii) Pre-Mixed Foam installation, (iv) High Expansion Foam installation.
- (b) A foam extinguishing system shall be automatically actuated during a fire with provision of manual actuation.
- (c) Warning sign and discharge alarm system shall be provided with the foam extinguishing system, which shall be actuated during the use of the system.
- (d) The system provides protection of boiler rooms with its ancillary storage of furnace oils in basement and other areas where hazardous liquids are stored.

4.3.1.3 Vaporizing liquid installation

Liquefied compressed Halogenated hydrocarbon is fed through distribution pipe works and specially designed discharged nozzles to the area need to be extinguished. Upon discharge the liquid immediately vaporized to form a heavy vapour which achieves very rapid extinction.

There are two types of Vaporizing liquid installation, such as total flooding system and Local application system. This system shall be installed in accordance with the specification of the manufacturer. Safe guards are necessary to prevent injury or death of personnel in area where the atmosphere may be made hazardous by the discharge.

4.3.1.4 Dry powder installation

Dry powder of certain chemicals installation consist of pipe work and discharge nozzle and pressuring media. This installation can be operated automatically or manually. This can be designed for total coverage and for zone coverage.

Dry powder is a range of chemical agents available as extinguishing media. They are used on various flammable liquids where they are confined. This system shall be installed in accordance with the specification of the manufacturer.

4.3.1.5 Gaseous installation

- (a) General: Gaseous extinguishing system shall be of an approved type and shall be installed as per provisions of this Code. The system supplies gas from a pressurized vessel through fixed pipes and nozzles.
- (b) The system is used where water or foam cannot be used for fire extinguishing because of the special nature of the contents within the building or areas to be protected.
- (c) The system shall be automatically actuated and shall be equipped with manual actuation devices as well.
- (d) Warning signs and discharge alarm shall be provided where persons are likely to be trapped in an area made hazardous due to discharge of extinguishing gases.
- (e) Halocarbon agents and inert gas system: Any approved Type of Halocarbon agents are chemicals in the liquid form at high pressure and vaporize readily leaving no residue. These are primarily to protect hazardous fire in enclosed room, vaults, machines, containers, storage tanks, engines, unattended computer server rooms, electrical appliances, liquid gas storage etc. Some example of these chemical is dichlorodifluoro ethane, chlorodifluoro methane. Inert gas system is also an alternative of Halocarbon agents. These are nitrogen and argon in pure form or in mixer at different proportion. These gases are identified as clean total folding fire suppression agents. They are stored in high pressure gas cylinders.

4.3.1.6 Dry chemical extinguishing system

- (a) General: Dry chemical extinguishing system shall be of an approved type and shall be installed in accordance with the provisions of this Code and manufacture's instruction.
- (b) The system shall be automatically actuated during a fire and shall be equipped with manual actuation device as well.
- (c) Warning signs and discharge alarm shall be provided where persons are likely to be exposed to chemical discharge. Chemical agents of the system shall be nontoxic.

4.3.1.7 Wet chemical extinguishing system

- (a) A wet chemical system is a solution of water and potassium carbonate or acetate based chemical which forms the extinguishing agent. The system shall be installed in accordance with the provisions of this Code and manufacturer's installation instruction.
- (b) The system shall be automatically actuated during a fire and shall be equipped with manual actuation device as well.
- (c) In case of wet chemical extinguishing system, label of the approved agent shall be affixed.
- (d) Warning signs and discharge alarm shall be provided where persons are likely to be exposed to wet chemical discharge.

4.3.2 Localized Fixed

Containerized extinguishing agent are available in different shapes and size to be placed in different locations those are prone to fire hazard as for example at the top of cookers in the kitchen, electric connection box etc. Use of these containers shall be approved type and installation shall be as per specification of the manufacturer.

4.4 Portable Fire Extinguisher

4.4.1 Portable fire extinguishers shall readily available in different type. These are portable fire extinguisher are of carbon dioxide types, dry chemical types, water types, and Halon types, film-forming type, foam types and Halon carbon type. For proper operation persons with adequate knowledge and familiar with their operation must be available.

4.4.2 In accordance with the occupancy hazard, specification of the manufacturer and guide line set by NFPA 10, the minimum number of portable fire extinguishers for different class of fire shall be ascertained. As for example where the floor area of a building is less than 279 m² at least one fire extinguisher of the minimum size is recommended for Fire Class A.

4.4.3 Portable fire extinguishers shall be fully charged, operable at any time and conspicuously located where they will be readily accessible. Portable fire extinguishers shall not be obstructed or obscured from view. In large rooms, means shall be provided to indicate the extinguisher location.

4.4.4 Portable fire extinguishers shall be adequately protected from impact, vibration, and adverse environment and shall not be exposed to temperatures outside the listed temperature range shown on the fire extinguisher label.

4.4.5 Portable fire extinguishers mounted in cabinets or wall recesses shall be placed so that the fire extinguisher operating instructions face outward. The location of such fire extinguishers shall be marked conspicuously.

4.4.6 The owner or designated agent or occupant of a property in which fire portable extinguishers are located shall be responsible for inspection, maintenance, and recharging. The procedure for inspection and maintenance of fire extinguishers varies considerably. Monthly "quick check" or inspection in order to follow the inspection procedure as outlined in NFPA 10 shall be done.

4.4.7 Maintenance, servicing and recharging shall be performed by trained persons having available the appropriate servicing manual(s), the proper types of tools, recharge materials, lubricants, and manufacturer's recommended replacement parts or parts specifically listed for use in the fire extinguisher. These extinguishers shall be maintained as per NFPA 10, at intervals of not more than one (1) year.

4.4.8 All rechargeable-type fire extinguishers shall be recharged after any use or as indicated by an inspection or when performing maintenance or as per the recommendations of the manufacturer.

4.4.9 For personal safety during approach with extinguishing equipment it shall be remembered that most fires produce toxic decomposition products of combustion and some materials can produce highly toxic gases. Fires can also consume available oxygen or produce dangerously high heat. All of these can affect the degree to which a fire can be safely extinguished.

4.4.10 All extinguishing agents other than clean agents shall be approved by the authorities having jurisdiction.

4.5 Rate of Water Flow For Fire Protection In Tall Building

High rise building exceeding 80 meter height shall be termed as Tall Building. The quantity, sources and mode of water supply in tall building shall be in accordance with Sec 4.2. In high rise buildings fittings and equipment for firefighting may be subject to excessive pressure.

Pressure on firefighting equipment in Tall building shall be reduced by dividing the building into different zones. In this process the building shall be divided into different water supply zones so that the firefighting equipment will serve within their maximum allowable limit of pressure. Separate automatic fire pump or combination of tank and automatic pump shall be installed for supplying water to the firefighting equipment in each zone as per Figures 4.4.7 and 4.4.8.

4.6 Fire Detection and Alarm System

4.6.1 Fire Detection Shall be Done by the Following Ways

(a) Human surveillance:

Human surveillance shall be acceptable where the user and occupant are capable of maintaining surveillance for detecting fire and smoke when a person appointed and assigned to detect fire shall be termed as Fire watch.

(b) Automatic smoke or/and heat detection :

The installation of automatic fire and smoke detection system shall be a necessity when the size, arrangement and occupancy of a building become such that a fire itself cannot provide adequate warning to its occupants.

The automatic fire and smoke detection system shall include, spot or line type heat sensitive detectors and optical, ionized or chemical sensitive type of smoke detectors.

(c) Video surveillance :

Cameras capable of registering and transmitting real time images in to a monitoring device having display commonly termed as CCTV shall be installed systematically to cover an area for detecting any incision of smoke and fire. This CCTV will remain under either human surveillance or monitored by compatible software to transmit signal automatically to the fire alarm system and also to the authorized persons.

4.6.2 Fire Alarm System

4.6.2.1 In a fire incident, panic management shall be the prime concern for a successful relocation, delayed egress or evacuation of occupants from a building structure. Activation of alarm shall be sequential and compatible with all design scenarios. Means of egress system is so designed that all alarms of a building shall not be activated at a time. A general announcement of fire shall be done for the occupant or the word "Fire" shall be avoided but authorized persons responsible for evacuation shall be alerted through Password or Pass Phrase. As per design scenarios a systemic execution protocol shall be developed where a building shall be sub-divided into zones for installation alarms and for fight in place, relocation of occupants, delayed egress or immediate evacuation.

Alarm system can be of different types, such as audible alarm, visual alarm, vibration alarm, and display alarm.

- (a) Audible alarm: Ringer, bell, horn, chime and voice command via public address system (PA system) are the examples of audible alarm system.
- (b) Visual Alarm: A bright white light emitting device with specific intensity and cycle of emission is capable to draw attention of a person having limited hearing shall be termed as visual alarm. A visual alarm shall be installed where a person working alone in a room or a space having hearing limitations. In a public place or in any place more than two persons are present and one having normal hearing ability shall not require to install visual alarm.
- (c) Vibration Alarm: Alarm activated through vibration can be used for alarm.
- (d) Display Alarm: Textual, graphical or pictorial display on screens or monitors can be used as alarm.

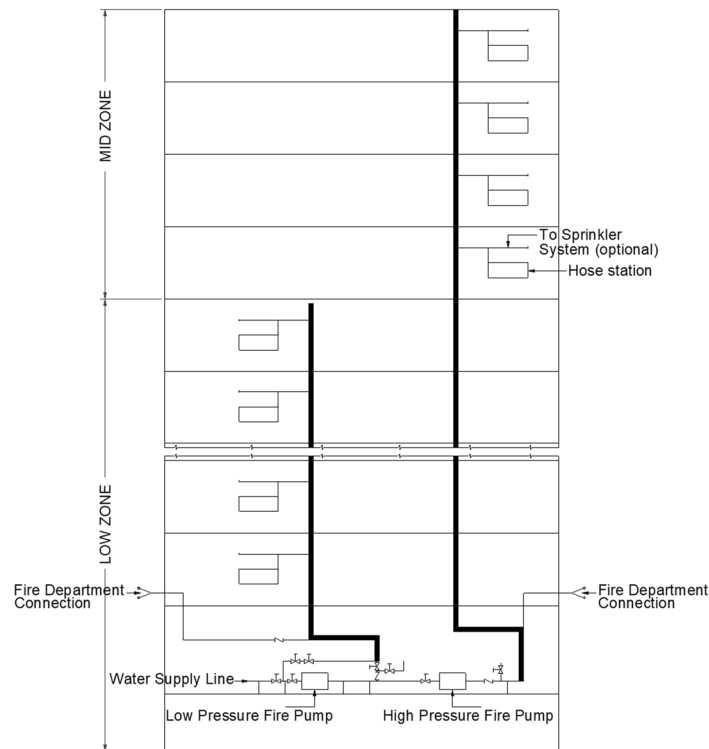


Figure 4.4.7 Typical diagram for fire protection in different water supply zones of a tall building

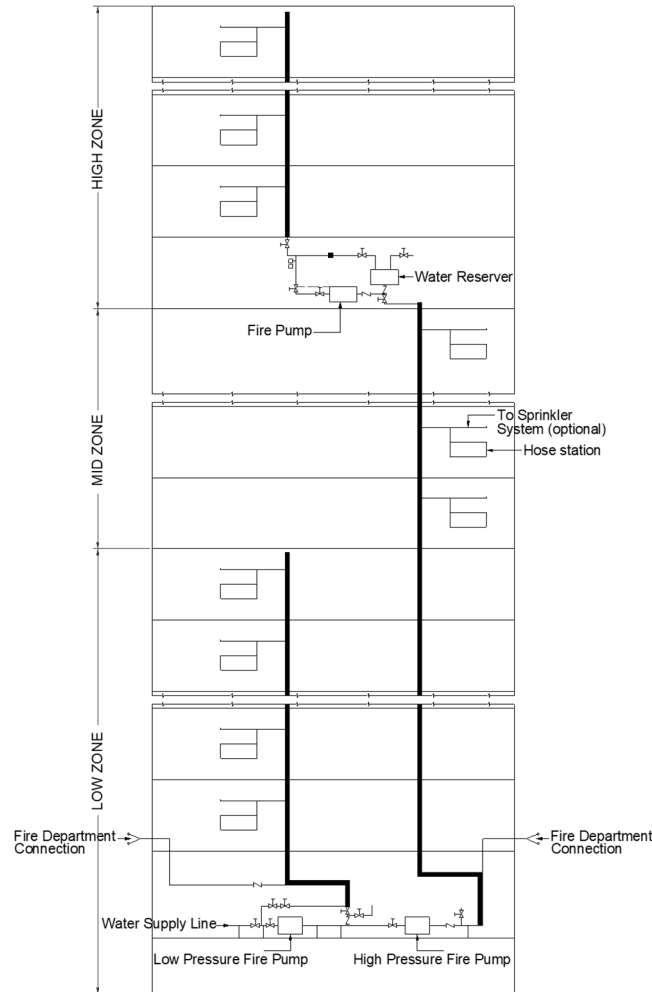


Figure 4.4.8 Typical diagram for fire protection in different water supply zones of a tall building

4.6.2.2 Each floor shall be separated as zone for the purpose of alarm annunciation.

4.6.2.3 A floor is subdivided by fire or smoke barriers and allows relocation of occupants from area of incident to another area on the same floor each area shall be considered as a zone and annunciated separately for the purpose of alarm location.

4.6.2.4 Notification zones shall be consistent with emergency response or evacuation plan for the protected premises. The boundaries of notification zones shall be coincident with building peripheral walls, fire or smoke compartment boundaries, floor separations or other fire safety subdivisions.

4.6.2.5 If required by the authorities having jurisdiction, the alarm system be allowed the application of alarm signal to one or more zones at the same time, shall allow voice paging to the other zones or in any combination.

4.6.2.6 Alarm annunciation at the fire command center shall be by means of audible and visible indicators.

4.6.2.7 Activation of fire extinguishment system shall have a supervisory alarm. An automatic extinguishment system capable of discharging other than water extinguishing agents shall have dedicated and distinct alarm system and shall be actuated before discharging such agents.

4.7 Related Appendix

Appendix C Detail Guidelines for Selection and Sitting of Fire Detection System

PART IV
Chapter 5

Requirements For Fire Detection and Extinguishing System

5.1 Scope

Installation of fire detection and firefighting equipment fixed centrally or localized or portable and their arrangement in the buildings shall be performance based. Construction type and occupancy classification of Buildings shall be as per provisions of this Code. Part 3 of this Code shall be determinant of construction type and the A-Z list for occupancy classification. Installation of fire detection and firefighting equipment shall comply with the Chapter 4 of Part 4 of this Code.

Intent of this Chapter is to reduce the probability of fire incident by confinement, extinguishment to reduce probability of injury or death from fire, structural failure due to fire and safety of building use.

Provisions of this Chapter shall be considered as minimum requirement and shall not be intended to prevent additional installation of higher standard of equipment.

5.1.1 Performance based fire protection system which includes “Passive” that is arrangement of building components and “Active” means detection, alarm, extinguishment devices and equipment which shall be incorporated in all buildings unless otherwise specified in this Code. Performance based design considerations shall be as follows:

- (a) The starting of a fire incident shall be a single source to evaluate the fire protection system.
- (b) The prime objective of a fire protection system to safe life and minimization of property damage shall be achieved by using required design scenarios and the performance criteria to be fulfilled. Each design scenario shall be challenging as realistic and the probability of occurrence is present in the building shall be reduced and protected.
- (c) Design scenario shall include but not limited to those specified in Sections 5.1.2 to 5.1.4 and shall be documented and demonstrated to the satisfaction of the authorities having jurisdiction.
- (d) Each design scenario used in the performance-based design shall be translated into input data specification as appropriate for calculation method or model.

- (e) Input data of any design scenario did not analyzed and explicitly addressed or incorporated shall be omitted from input data specifications, shall be identified by a sensitivity analysis of the consequences of the modification for such omissions shall be performed.

5.1.2 Design Scenario I

Fire Class and Fire resistance rating shall be determined as per provision of this Code for the followings:

- (a) All surface finish materials.
- (b) Structural Members.
- (c) Joints of Structural Members.
- (d) All slabs.
- (e) Roof Slab.
- (f) Joints between Slabs.
- (g) All Exterior Walls.
- (h) All Interior Walls.
- (i) Partitions.
- (j) Suspended Ceiling.

Construction classification and the structural stability shall be concluded and documented.

5.1.3 Design Scenario II

Occupancy specific design scenario representative of a typical fire shall explicitly specify the following:

- (a) Occupant activities.
- (b) Number and location of occupants.
- (c) Room size.
- (d) Number of Control Area.
- (e) Furnishings and contents.
- (f) Fuel Properties represented by Fire Class and ignition sources.
- (g) Ventilation conditions.
- (h) First item ignited and its location.

5.1.4 Design Scenario III

- (a) The largest possible fuel load characteristic of the normal operation of the building shall be considered regarding a rapid developing fire in presence of occupants.
- (b) A slow-developing fire shielded from protection in the close proximity to a high occupancy area shall be considered a concern regarding a relatively small ignition source causing a significant fire.
- (c) A concealed space or suspended ceiling space adjacent to a large occupied room shall be considered a concern regarding a fire originating in a concealed space that does not have either detection system or suppression system and then spreading into the room within holding the greatest number of occupants.
- (d) An Ultrafast developing fire in the main exit access portion in a condition when interior doors are open but reduction in number of available of means of egress shall be considered.
- (e) A room normally unoccupied from where a fire starts that can potentially endanger a large number of occupants in a room or other area shall be considered.
- (f) The concern regarding exposure of fire outside of an area of incident started at a remote location either spreading from the area or bypassing barriers spread into another area and developed untenable condition thereof.
- (g) The reliability and the design performance shall be considered for fire detection and protection system in such a way that a fire originating in ordinary combustibles in a room with each passive or active fire protection system or fire protection feature independently rendered ineffective shall be considered individually being unreliable or becoming unavailable. This scenario shall not be considered for a room or a space or a building where fire detection and protection systems or any independent features are absent.

5.1.5 Fire class shall be determined for all movables in each room and all control areas in the building.

5.1.6 Fire Protection Plan

A building or part thereof must have a fire protection plan for the following cases.

- (a) High rise building or building sections 33 m and above in heights.
- (b) Building or building sections classified in the occupancy groups G, H, J, K and M which are two or more storey in height with over 1858 m² per gross floor area or are two or more in height with total area exceeding 4717 m² gross floor area.
- (c) Building classified as A3 containing 30 or more dwelling units; A4 and A5 having gross floor area of the building more than 1200 m².
- (d) Part of a building used as mercantile, assembly, institutional or health care having gross floor area of the building over 930 m².
- (e) Alteration to a building or a portion thereof listed in Sections 5.1.6(a) to 5.1.6(d) above, if cost of alteration equivalent to one third cost of new construction of the same or more or involves changes in occupancy classification.
- (f) The plan shall include information where applicable building address, height in meter, occupancy classification, detail occupant load.
- (g) Key Plan shows all floors, exits, corridors, partitions serving as fire separations or compartments, locations and ratings of required enclosures, windowless stair with pressurization, exit discharge, locations of frontage space including street width of abutting plot.
- (h) Descriptions in narrative forms of safety systems and features where applicable, including:
 - Communications systems
 - Alarm system
 - Detection systems
 - Location of fire command station
 - Elevator recall
 - Emergency lighting and power
 - Extinguishing equipment
 - Compartmentation
 - Horizontal exits
 - Mechanical ventilation and air conditioning

- Smoke control systems and equipment
 - Furnishing type and materials
 - Places of assembly
 - Fire department access
 - Other system, required or voluntary to be installed
- (i) A fire protection plan shall be signed by the same architect who is signing on the proposed drawings for building approval and any person responsible for the Fire protection design.

5.2 Specific Recommendations

Specific recommendations applicable for buildings complied with the followings:

5.2.1 All building constructed monolithically as per provisions of this Code as an inherent full fire resistive construction type shall be termed as Type I-A.

5.2.2 All surface finishes shall be Class-I within the range of zero to twenty five flame spread index.

5.2.3 Any offsite construction, pre-stressed, pre-fabricated or steel structure encased with fire resistive assembly shall be termed as Modified Type I-A.

5.2.4 The following recommendations for fire protection system specified in Sections 5.3 to 5.14 are made based on construction type and surface finishes specified in Sections 5.2.1 and 5.2.2 respectively.

5.2.5 All buildings of any occupancy type and construction type as per provisions of this Code other than Sec 5.2.1 with all surface finish as per Sec 5.2.2 shall provide a performance based fire protection.

5.3 Occupancy A: Residential

The residential buildings complied with Sections 5.2.1 and 5.2.2 shall provide the following active fire protection:

5.3.1 Occupancy A1 and A2: Single Family Dwelling and Two Families Dwelling

- (a) For buildings having total floor area less than 500 m², fire detection and fixed firefighting arrangements is not required.
- (b) Buildings exceeding total floor area 500 m² shall have manual alarm system and portable extinguishers provided in the escape stairs route or in lift lobby and as per provision of this Code.

5.3.2 Occupancy A3: Flats and Apartments

- (a) Up to 33 m height fire detection and fixed firefighting arrangement shall not be required.
- (b) No protection is required within the dwelling units of high rise flats and apartments; manual alarm system and fixed hydrant system shall be provided in the landings of fire stairs or in the lift lobby as per the provisions of this Code.

5.3.3 Occupancy A4: Mess, Boarding House and Hostels

- (a) For buildings up to 2 storey height, fire detection, fire alarm and fixed firefighting arrangements shall not be required.
- (b) Buildings having 3 stories and having floor area less than 300 m² shall not require fire detection and fixed firefighting arrangements.
- (c) The floor area of 3 stories building having more than 300 m² per floor and less than 33 m height having central corridor with rooms on both sides, manual fire alarm system shall be provided along with portable fire extinguishers. Instead of double loaded corridor a single loaded corridor having 3 m width shall not require any detection and fixed firefighting arrangements.
- (d) High rise boarding house, mess and hostels manually operated electric fire alarm system shall be provided along with hydrant system.

5.3.4 Occupancy A5: Hotels and Lodging Houses

- (a) For buildings up to 2 storey height, fire detection, fire alarm and fixed firefighting arrangements is not required.
- (b) Buildings having 3 floors or above and having floor area less than 300 m² shall not require fire detection and fixed firefighting arrangements.
- (c) The floor area of such building is more than 300 m² per floor and low rise building having central corridor with rooms on both sides, manually operated fire alarm system shall be provided along with portable fire extinguishers. For low rise buildings with other configurations performance based firefighting system shall be required as per the provisions of this Code.
- (d) High rise hotels and lodging houses manually operated electric fire alarm system shall be provided along with hydrant system.

5.4 Occupancy B: Educational

The educational buildings complied with Sections 5.2.1 and 5.2.2 shall be provided with the following active fire protection:

5.4.1 Low rise buildings with open corridor of 3m width fire detection and fixed firefighting arrangements shall not be required.

5.4.2 High rise building or building having central corridor with classrooms on both sides, manual fire alarm and hydrant systems shall be required as per provisions of this Code. Single loaded open corridor having width of 3 m or more shall have detection and manual alarm systems.

5.4.3 Where hydrants cannot be used to extinguish fire in those areas appropriate portable firefighting appliances shall be installed as per standard.

5.5 Occupancy C: Institution For Care

The Institution for care buildings complied with Sections 5.2.1 and 5.2.2 shall be provided with the following active fire protection:

5.5.1 Occupancy C1: Institution for Care of Children:

Fire detection and fixed firefighting arrangements shall not be required. Portable firefighting appliances shall be installed as per the provisions of this Code.

5.5.2 Occupancy C2: Custodial Institution for the Physically Capable adults:

Fire detection and fixed firefighting arrangements shall not be required. Portable firefighting appliances shall be installed as per the provisions of this Code.

5.5.3 Occupancy C3, C4, C5: Custodial Institution for the Physically Incapable, Penal and mental institutions for children and Penal and mental institutions for adults:

Manually operated electric fire alarm system shall be installed. Portable firefighting appliances shall be installed as per the provisions of this Code.

5.6 Occupancy D: Health Care Facilities

The Health care facilities buildings complied with Sections 5.2.1 and 5.2.2 shall be provided with the following active fire protection:

5.6.1 Occupancy D1: Normal and Emergency Medical Facilities:

- (a) Manually operated electric fire alarm system or automatic fire alarm system shall be installed in the duty room, so that the duty personnel receive the fire warning well in advance. Portable fire fighting appliances shall be installed as per the provisions of this Code.

- (b) For low rise health care facility buildings with more the 300 m² per floor, performance based fire fighting system shall be required as per the provisions of this Code.
- (c) For high rise health care facility buildings, manually operated electric fire alarm system shall be provided along with hydrant system.

5.7 Occupancy E: Business

The Business buildings complied with Sections 5.2.1 and 5.2.2 shall be provided with the following active fire protection:

Buildings	Active Fire Protection
(i) Office buildings up to 2 storey high and 500 m ² single effective undivided space in a floor.	Portable fire extinguishers or hydrants.
(ii) Office buildings more than 2 storey high or more than 500 m ² single effective undivided space in a floor.	Manually operated electric fire alarm system shall be provided along with portable fire extinguishers or hydrants.
(iii) Laboratories with precession instruments.	Automatic fire alarm system and performance based extinguishing system.
(iv) Control areas of office buildings dealing with flammable liquids.	Automatic foam or gaseous or dry chemical fire extinguishing system required along with portable fire extinguishers.
(v) Solvent storage in a control area of an office	Automatic fire alarm system and performance based foam or gaseous or dry chemical fire extinguishers or portable fire extinguishers.
(vii) Telecommunication, Internet gateway equipment or computer installation in an unattended server room.	Automatic fire alarm system and performance based fixed gaseous or fixed vaporizing liquid extinguishers or portable fire extinguishers.
(viii) Electrical low tension distribution panel room in a sub-station.	Automatic fire alarm system and performance based localized fixed gaseous or vaporizing liquid extinguisher or portable fire extinguishers.
(ix) Space under one false ceiling more than 500 m ²	Automatic fire alarm system shall be installed for above and under the false ceiling.

Buildings	Active Fire Protection
(x) Essential Services (Occupancy E3)	Due to importance of services and the functionality of the building of this occupancy classification during any national or local emergency situation thus the fire protection system design shall be performance based (Sec 5.1.1).
(xi) High rise office buildings	Manually operated electric fire alarm system shall be provided along with hydrant system.

5.8 Occupancy F: Mercantile

The Mercantile buildings complied with Sections 5.2.1 and 5.2.2 shall be provided with the following active fire protections:

5.8.1 Occupancy F1: Small Shops and Markets

Mercantile	Active Fire Protection
(i) Whole sale establishments, transport booking establishments.	Manual fire alarm system shall be provided along with portable fire extinguishers or hydrant.
(ii) Other premises (other than shops, stores, markets etc.)	Manual fire alarm system shall be provided along with portable fire extinguishers or hydrant.

5.8.2 Occupancy F2: Large Shops and Markets

Mercantile	Active Fire Protection
(i) Shopping arcade with central corridors open to sky	Manual fire alarm system and portable fire extinguishers shall be provided or hydrant.
(ii) Mercantile building under covered roof with single effective undivided space more than 500 m ² on each floor	Manual fire alarm system and hydrant system with performance based portable fire extinguisher shall be installed.
(iii) Underground mercantile structure	Automatic fire alarm system, sprinklers and standpipe with performance based portable fire extinguisher shall be installed.

5.8.3 Occupancy F3: Petrol and CNG Stations

Mercantile	Active Fire Protection
(i) Petrol pump and CNG station, automobile garages	Fixed automatic foam or gaseous or dry chemical fire extinguishing system shall be provided along with portable extinguisher.
(ii) Aircraft hangars	Automatic foam or gaseous or dry chemical fire extinguishing system shall be provided along with portable extinguisher.

5.9 Occupancy G: Industrial

The Industrial buildings complied with Sections 5.2.1 and 5.2.2 shall be provided with the following active fire protection:

5.9.1 Occupancy G1: Low Hazard Industries

Manually operated electric fire alarm system shall be installed with portable fire extinguishers or hydrants when occupant loads are not more than 150.

Where occupant loads are more than 150 active fire protections shall be performance based.

5.9.2 Occupancy G2: Moderate Hazard Industries

Among the moderate hazard industries where large number of occupants are densely populated in a building, the active fire protections shall be performance based. Fire safety requirement for such type industry is elaborated as follows:

- (a) Where occupancy load is more than 150 per production area shall have minimum 9.5 m³ air volume per occupant.
- (b) There shall have direct exits from the ground floor. This exit doors shall be used by only the occupant of the ground floor.
- (c) Buildings less than 33 m in height shall have open stair and the interior stairs shall be protected by fire rated enclosures. Occupants located 33 m or above, all stair shall have smoke proof enclosures constructed as per provision of the Code.
- (d) All windows or openings on exterior walls passable by occupant located above 3 m in height shall be protected by grills and all these grills shall be designed as such that a part or a portion having minimum 0.6 m height and minimum 0.75 m width framed and the grill within the frame shall be side hinged or pivoted so that it can swing. This swing type operable portion must be always locked and in case of emergency the firefighters can open by breaking the lock for rescue operation.

-
- (e) The floor shall be constructed such that the travel path of the occupant shall not be exceeded as per Table 4.3.7 of this Code.
- (f) As per general requirements, all exit access doors shall be of a side-swinging type. Fulfilling the conditions laid down by NFPA 101, edition 2015, article 7.2.1.4 horizontal sliding or vertical-rolling security grills or door assemblies that are part of the required means of egress shall be permitted.
- (g) All raw materials, finished good and accessories shall be stored in control areas as per provision of part 3.
- (h) Density of storage materials per control area shall not be exceeded the provision of this Code.
- (i) During production that is feeding, checking for quality control rejects, waiting area for finishing, packing, cartooning etc. in every case dedicated area shall be defined as on process storages. The total volume of materials on process shall be such that in every four hour the material shall be used up and the finished goods shall be transferred to controlled area as finished goods store.
- (j) From each end every work station shall be connected with a passage. The width of the passage shall comply with the provision of this Code Chapter 3 Part 4.
- (k) Cargo lift and passenger lift shall have smoke proof lift lobby.
- (l) Occupant load in a single effective undivided space shall not exceed 600. In case of existing building if the occupant load of a single effective undivided space exceeds 600, the space shall be compartmented complying with the horizontal exit provision of the Code.
- (m) Where control areas and in process stores having materials may cause a fire classified as fire class A shall have hydrant system as per provision of this Code. In the utility occupancy areas fire extinguishing system shall be installed as per provision as specified for utilities of this Code.
- (n) If there any change of fire classification due to the working condition or raw materials than appropriate extinguishing system shall be installed as per provision of this Code.
- (o) Up to 750 m² single effective undivided space in a floor shall be installed with manual fire alarm system with portable fire extinguishers or as an alternate hydrants system shall be installed as per provisions of this Code.
- (p) Above 750 m² single effective undivided space in a floor shall be fitted with manual fire alarms system with hydrants shall be installed.

5.10 Occupancy H: Storage

The Storage buildings complied with Sections 5.2.1 and 5.2.2 shall be provided with the following Active fire protection:

5.10.1 Occupancy H1: Low Fire Risk Storage

Manually operated electric fire alarm system shall be installed. Depending on the type of materials to be stored, performance based fire protection shall be installed as per provision of this Code.

5.10.2 Occupancy H2: Moderate Fire Risk Storage

Performance based fire protection system shall be installed as per provision of this Code.

5.11 Occupancy I: Assembly

The Assembly buildings complied with Sections 5.2.1 and 5.2.2 shall be provided with the following Active fire protection:

5.11.1 Occupancy I1: Large Assembly with Fixed Seats

All auditorium, corridor, green rooms and canteen attached to assembly buildings shall be fitted with manual fire alarm system and the performing stage should preferably be covered by an automatic sprinkler system. Portable firefighting appliances shall be installed as per specification of the manufacturer and provision of this Code.

5.11.2 Occupancy I2: Small Assembly with Fixed Seats

Requirements specified in Sec 5.6.1 shall be complied.

5.11.3 Occupancy I3: Large Assembly without Fixed Seats

Automatic fire alarm system shall be provided. Portable firefighting appliances shall be installed as per specification of the manufacturer and provision of this Code.

5.11.4 Occupancy I4: Small Assembly without Fixed Seats

Requirements specified in Sec 5.6.3 shall be complied.

5.11.5 Occupancy I5: Sports Facilities

Manually operated electric fire alarm system shall be provided. Portable firefighting appliances shall be installed as per specification of the manufacturer and provision of this Code.

5.12 Occupancy J: Hazardous

The Hazardous buildings complied with Sections 5.2.1 and 5.2.2 shall be provided with the following Active fire protection:

All hazardous occupancies shall be installed with automatic fire alarm and automatic fixed firefighting gaseous or foam or dry chemical extinguishing system as compatible with class of fire shall be installed as per provision of this Code.

5.13 Occupancy K: Garages

The parking buildings (garages) complied with Sections 5.2.1 and 5.2.2 shall provide the following fire protections:

- (a) Where both parking and repair operations are conducted in the same building, the entire building shall comply with the requirement stated in this Code for Occupancy G1.
- (b) Where the parking and repair sections are separated by not less than 1-hour fire-rated construction, the parking and repair sections shall be permitted to be treated separately.
- (c) In areas where repair operations are conducted, the requirement of Occupancy G1 shall be fulfilled.
- (d) The area used only for parking shall fulfill the requirement as laid down in chapter 42 of NFPA 101 edition 2015.

5.14 Occupancy L: Utilities

Fire protection system shall be as stated in Sec 2.12 of this Code.

5.15 Occupancy M: Miscellaneous

Performance based fire protection system shall be installed.

PART IV
Appendix A
Guidelines For Fire Drill and Evacuation Procedure

A.1 Introduction

The following provisions shall be applicable for emergency reporting, fire safety and evacuation plan of the occupants of different occupancies.

A.2 Fire Reporting

Any occupant within the occupancy discovering a fire or smoke shall immediately report the incident to the fire brigade directly or through the ground command station, if there is any. Reporting of this situation shall not be delayed by any person by way of making, issuing, posting or maintaining any regulation or order written or verbal to that effect.

A.3 Supervision of Fire Safety and Emergency Action and Plans

The owner shall designate competent persons to act as fire safety and evacuation plan staff, train the staff and conduct fire drill. Such persons shall possess such qualifications and/or hold such certificate of fitness as are required by the provisions of this Chapter. The owner shall ensure that adequate fire safety and evacuation plan staff is present on the premises during regular business hours and other time when the building is occupied, to perform the duties and responsibilities set forth in the fire safety and evacuation plan.

A.4 Fire Safety Staff

A.4.1 The fire safety and evacuation plan shall designate a fire safety director, a number of deputy fire safety directors and fire safety brigade members having following duties, authority and qualifications.

A.4.2 Fire Safety Director

- (a) The fire safety plan shall contain the name of fire safety director, whether employed by a fire security firm or directly employed by the management.
- (b) Depending on the size and complexity of the building, the Fire Safety director shall be a person of proven capability, having good training and schooling with adequate experience in dealing with fire.

-
- (c) The fire safety director shall be present in the building during regular business hours. Duties of Fire Safety director shall primarily include but not be limited to the following :
- (i) Shall be well conversant with the written fire safety plan for the fire drill and evacuation procedures.
 - (ii) Shall be in charge of selecting qualified building service employees for the fire command and engage in organizing, training and supervising the works of command crew.
 - (iii) Shall be responsible to conduct fire and evacuation drill.
 - (iv) Shall be responsible for the availability and state of preparedness of fire command crew during emergencies.
 - (v) Shall be responsible for the assignment and training of Fire fighters on floor supported by adequate number of deputies as detailed out in the fire safety plan.
 - (vi) Shall be responsible for the day to day supervision of the fire fighters and his deputies and the state of alertness of the fire fighters. When the number of fire fighters and deputies become such that it becomes impractical for the chief fire safety officer to check them directly during the working hours, he may provide substitute. Nonetheless the fire safety director shall spot check any number of floors as he wishes or time permits. An up to date organization chart shall be displayed at appropriate locations.
 - (vii) Cases of negligence to duties on the part of members of his crew shall be taken up by him and he shall rectify the situation by appropriate measures as far as he has been empowered under the fire safety plan, failing which he shall notify the matter to the owner or the management of the building. The owner or the management on their part shall take up the matter with the fire security firm or if employed directly shall deal with the matter directly. If the person/persons is/are employed by a firm, and the firm fails to correct the situation, the owner/management shall notify the matter to the Department of Fire Service and Civil Defence to take disciplinary action against the firm.

- (viii) In the event of fire/emergency he/she shall be in charge of fire command station and shall supervise, guide and coordinate activities such as ensuring that the Department of Fire Service and Civil Defence has been notified of fire or fire alarm, direct the evacuation procedure as detailed in the fire safety plan, manning the fire command station, appraise the Department of Fire Service and Civil Defence about the spot of fire on their arrival, advise the Department of Fire Service and Civil Defence officer in charge of the operation.

A.4.3 Fire Safety Deputy Director

The fire safety plan shall contain the details of Deputy Fire Safety Director similar to the details mentioned under the fire safety director. Qualification and experience of Deputy Fire Safety Director shall also be similar to those of the Fire Safety director excepting that he shall be less experience than the Director.

Tenant or tenants of each floor upon request by the owner or in-charge of the building shall assign and make available dependable and trustworthy person/persons under their employee at the disposal of the Director to act as fire safety coordinator and fire fighter. They shall undergo basic firefighting and evacuation training by the Director or his deputy.

Duties of the Deputy Fire safety Director shall be similar to those mentioned under Sec A.4.2 except that he shall receive command from the Fire Safety director for execution and shall assume the role of Fire Safety director in his absence.

Each floor of a building shall be under the command of a deputy fire director for the safe evacuation of inmates in the case of fire. When the floor area of a tenant exceeds 700 m², a deputy fire director shall be assigned for each 700 m² or part thereof.

The deputy fire safety director shall be present in the building at all times. Duties of deputy Fire Safety director shall primarily include but not be limited to the following :

- (a) Each Deputy Fire Safety director shall be conversant with the fire safety plan. They must be well acquainted with fire exits and location and operation of fire alarms.
- (b) In case of fire or fire alarm, the deputy Fire Safety director shall ascertain location of fire and unfold evacuation procedure as directed from the command station and to the following general guides.
 - (i) The most critical area for immediate evacuation would be the fire floor and the floors above. Evacuation from other floors shall be initiated if so commanded by the ground command station or the situation indicates to be so. Evacuation should be carried out via stairs not influenced by fire and fire fighter shall try to carry out the operation

using stair other than the ones used by the Department of Fire Service and Civil Defence personnel. If it becomes impossible, the fighters before opening door to the fire floor shall sought advice from the Department of Fire Service and Civil Defence personnel.

- (ii) Evacuation from two or more floors below the fire floor should be adequate. He shall continuously keep the ground command station informed of his location.
- (iii) Ensure that fire alarm has been transmitted.
- (iv) Fire fighters shall ensure that all the inmates are intimated of the emergency and shall immediately proceed with the evacuation exercise detailed under Fire Safety Plan.
- (v) Fire fighter shall keep the ground station informed of the step being taken by him/her.
- (vi) Similarly fire fighter above fire floor shall notify the command station of the means being taken by him/her or any other special feature after unfolding Fire Safety Plan.
- (vii) If and when stairways serving fire floor/floors above become useless by the presence of fire, smoke, fumes, in several floors above and when fire engulfs a considerable number of inmates then use of elevators shall be considered in accordance with the followings:
 - If the elevator serving the floor to be evacuated also serves the fire floor, the lifts shall not be used if it is not fire lift. If there are more than one lift bank, however, the lift/lifts in the other bank may be used if notified by the ground command station that one may use such lift/lifts.
 - If the lifts do not serve the fire floor or lift shaft has no opening on the fire floor, they may be used if not otherwise instructed by the command station.
 - Elevators taken over by trained in-house person or Department of Fire Service and Civil Defence personnel may be used.
 - In absence of unaffected available lift/lifts, Fire fighter shall decide to use the fire stair for evacuation based on considerations/ information available on the floor and any other instruction received from ground command. Before entering the fire stairway with the evacuees, the Fire fighter shall be sure about the

environment within the fire stairway by personal inspection and in case of adverse environment consider using an alternate stairway and shall notify the ground command accordingly.

- The Fire fighter shall keep the ground command informed of the means adopted by him during the evacuation process.

A fire safety coordinator and fire fighter shall be available at all times other than normal working hours when the Fire Safety Director or his Deputy is not available within the building.

Fire safety coordinator shall be a person capable of directing the evacuation procedure of occupants within the buildings as detailed in the Fire Safety Plan.

During fire/emergencies, primary function of fire safety coordinator shall be to take over command of the ground station and to direct and execute the evacuation process as laid down in the plan.

Fire safety coordinator shall be trained by the Director and shall be under his command for all evacuation purposes. His activities shall be controlled and governed by the clauses in Fire Safety Plan and shall be subject to scrutiny of the Department of Fire Service and Civil Defence.

Fire Party: If, in the opinion of the Fire Safety Director and endorsed by the Department of Fire Service and Civil Defence that the number of fighter, coordinator and Deputy are inadequate, a Fire Party shall be raised from among the employees of the tenants and the management who shall be acting as help to regular in-house fire fighting force in the event of fire and follow the same work schedule and function in the same manner as fighter, coordinator and Deputy fire safety director do.

A.5 Signs And Floor Plans

A.5.1 The lettering, arrows and other symbols of exit signs shall be written with vernacular alphabets high contrast background as per NFPA 170. Words on the signs shall be at least 150 mm high with a stroke of not less than 20 mm. For vernacular alphabets and numerics at least 150 mm high with stroke of not less than 20 mm. The sign/signs may be posted directly above the call button of the lift or any other conspicuous location securely attached to the surface of the wall. The top of the sign shall not be more than 2 m above floor level.

Sign shall be posted and maintained in front of the landing area of lifts on all floors that occupants may not miss, which shall direct the occupants to use stairs and not lifts during emergencies/fires, if not directed otherwise and shall also contain a floor plan with exact location of the stair and the relative position between the sign and the stair. Such posting in front of the landing area of lifts shall be omitted only if such signs are posted on all floors and some other area conspicuously located with the same message inscribed on it.

A.5.2 Sign Depicting Floor Number

A sign shall be posted and maintained on each stair enclosure preferably on the wall of the intermediate landing which in actual fact shall be half storey more or less than the actual indicating the floor number. The number shall be at least 75 mm square and in vernacular alphabets with contrast background as per NFPA 170.

A.5.3 Stairs and Elevators Identification

Each stair and Elevator shall be identified by a vernacular alphabet and posted with a sign, securely placed preferably on the wall of the stair side of the lift door from which egress is to be made.

A.5.4 Stair re-entry Provision

A sign shall be posted and maintained on each floor within stairway and on the occupancy side of the stairway where required, indicating whether re-entry is provided into the building and the floor where such re-entry is provided.

A.5.5 Command Station

Command station on the ground floor shall be provided with a detailed floor plan of the entire building including detailed locations of all first aid, firefighting equipment and other pertinent information. Command stations shall be adequately illuminated.

A.5.6 Two Way Communications and Fire Alarm

A two way communication system between each floor and the command station on the lobby of the entrance floor shall be provided and maintained by the owner of the building. Similarly fire alarm on each floor and the command station shall be fitted and maintained.

A.6 Fire Safety Plan

A.6.1 A fire safety plan shall be developed in line with the details elaborated as below and must have the approval of the local Department of Fire Service and Civil Defence regarding its adequacy.

A.6.2 Fire safety plan elaborates the purpose and objective of the plan with details of personnel and their duties and fire drilling and evacuation plan. In developing fire safety plan, evaluation of all individual floor layout, total occupancy load on each floor, number and kinds of exits available, zoning of the floor by area and occupancy shall be taken into consideration, careful evaluation of occupant movements and the most expeditions routes to exit and alternate routes shall be identified and taken into consideration.

A.6.3 Fire safety plan starts with the location, address of the building with telephone number and details of any other communication facilities available within the building.

A.6.4 Purpose of the plan is to delineate details of systematic safe and orderly evacuation of a part or whole of the building by its occupants in case of fire/emergency in the shortest possible time to a safe area through the safe means of egress. It also details out the use of in-built facilities of fire warning and firefighting like fire alarm, first aid hose etc. to safeguard the lives of the inmates of the building.

A.6.5 Objective of the plan is to provide continued education to the inmates and the fire command personnel and keep the people oriented to the in-built equipment in readiness to act in the event of fire. The plan shall be rehearsed through fire drill and the written plans containing instruction shall be updated if needed and use of the in-built equipment along with initiating fire safety procedure to safeguard life in case of fire until the fire brigade arrives.

A.6.6 Once the plan is accorded after approval by the Department of Fire Service and Civil Defence, the plan shall be distributed to all the tenants of the building by the building management, including the employees of the tenants and employees of the management.

A.6.7 If the building is owned by an individual or a single corporate body and the owner or right holding member/members of the corporate body are residing in the building shall be equally subject to fire safety plan applicable to other tenants.

A.6.8 All major changes in the safety plan shall be promptly reported to Department of Fire Service and Civil Defence for their approval.

A.7 Fire Drills

A.7.1 Fire drill shall be conducted as detailed under the fire safety plan. The frequency of fire drill shall be as per table shown below. All occupants of the buildings, building service employees including fire safety and evacuation plan staff shall participate in the fire drill. However, the very old, convalescent patients or otherwise incapacitated inmates are not obliged to actively take part in the exercise, except the fire man and his staff and family members of such person shall chalk out a clear plan as to how to evacuate in a real emergent situation with such incapacitated persons.

A.7.2 A record of such drills shall be kept in writing for at least 3 years for the inspection Department of Fire Service and Civil Defence whenever called for. The frequency of such fire drill shall be as mentioned in Table 4.A.1.

Table 4.A.1: Fire Drill Frequency

Occupancy	Frequency
Industry Having occupancy more than 150	Monthly
Industry Having occupancy less than 150	Quarterly
Mercantile occupancy more than 150	Quarter
Mercantile occupancy less than 150	Half yearly
School, College, Universities	Half yearly
High rise building	Half yearly
Tall building	Quarterly

A.8 Organization Chart For Fire Drill And Evacuation Assignment

- (a) An organization chart clearly delineating assignment attributed to designated employees shall be prepared as per fire safety plan and posted to all tenants and in very conspicuous location/locations on each floor. A copy of the chart shall be in possession of the fire safety director.
- (b) An updated list shall be continuously made available with the director, his deputy and coordinators and Fire fighter for all the disabled occupants unable to move without aid in the stairs. Arrangement shall be made in detail in the fire safety plan to have these inmates assigned in moving down the stairs two or more floors below fire floor. If it becomes necessary to move them still further down the stair, help may be sought of the elevator bank unaffected by fire and evacuated safely to ground floor. In case any extra assistance is needed, the director shall be notified.
- (c) During fire or fire drill exercise, fire fighter shall be using arm band or such other identification.
- (d) During fire on the fire floor it is to be ensured that all inmates are notified and are evacuated to safe area. A rush search shall be carried out including lavatories that all the inmates have been covered and the person in charge of this operation shall be trained in accomplishing this task fast and flawless.
- (e) Persons not available on duty as per organization chart shall be promptly replaced as per contingency plan detailed in the fire safety plan.

- (f) On completion of evacuation operation, a head count shall be carried out of all the regular occupants known to have occupied the floor evacuated.
- (g) Immediately on receipt of the alarm, the fire fighter shall take position near the two way communication station on the floor, so that he/she can maintain continuous contact with the ground command and receive instructions.

A.9 Instruction to Inmates of The Building

Once the fire safety plan has been approved by the Department of Fire Service and Civil Defence, the applicable portion of the plan shall be distributed to all the tenants and the management of the building who in turn shall pass it on to their respective employees. All the occupants shall actively participate and cooperate in carrying out the provisions of fire safety plan.

A.9.1 Fire Prevention and Protection Program

A Plan for periodic formal inspection of each floor shall be developed in respect of exit facilities, fire extinguishers and good housekeeping. Reports of such inspection shall be carefully maintained for inspection of Department of Fire Service and Civil Defence. The Plan shall have provision for monthly testing of two way communication and fire alarm system.

A.9.2 Personal Fire Instruction Card

All the occupants of the building shall be supplied with a personal Fire Instruction Card containing details of the floor plan and exit routes as well as instruction to be followed during fire. Instructions may contain the following either in Bangla or both in Bangla and English.

A.9.3 Detailed Building Information

A form shall be maintained for the benefit of all concerned with fire hazard of the building and shall contain the following basic information :

- (a) Building address in adequate details about its location.
- (b) Name, Address and telephone number of the owner (corporate body or individual) and the person in charge of the building.
- (c) Name address and telephone number if any, of the Fire Safety Director and his Deputy.
- (d) Certificate of occupancy.

-
- (e) Height, area, construction class (details of various load and non-load bearing elements).
 - (f) Number, type and location of fire stairs and/or fire towers.
 - (g) Number, type and location of horizontal exits or other refuge areas.
 - (h) Number, type location and operation of elevators and escalators (if any).
 - (i) Locations of fire alarm-floor wise and central.
 - (j) Communication System (telephone, mobile, walkie-talkie).
 - (k) Size and location of stand pipe system, gravity or pressure tank, fire pump and the name and qualifications of the person or persons in charge of the facilities.
 - (l) Automatic fire sprinkler system, primary and secondary water supply system and the area or areas being protected along with the name and qualification of the person or persons in charge.
 - (m) Any other fire extinguishing system, their location, efficacy and other pertinent details.
 - (n) Average number of employed persons by day and night.
 - (o) Average number of disabled persons visiting the building by day and night.
 - (p) Average number of outsiders visiting the building by day and night.
 - (q) Locations, types and capacities of other service facilities like primary and standby electric power, normal and emergency lighting arrangement, heating with fuel (if any), ventilation with fixed windows, other means of emergency exhaust facilities of smoke and heat, air-conditioning system including floor coverage and ducting, refuse disposal facilities, any other firefighting equipment, any other service facilities available.
 - (r) Measures taken or to be taken for addition, alteration and repair of any aspect within the buildings.
 - (s) Information on flammable solids, liquids and gases if used and stored within the building premises.
 - (t) In mixed occupancy, complete details of such occupancies and their special needs to be covered during fire or emergencies.

A.10 English Text of Instructions

- (a) Safety First
- Push button fire alarm boxes (number is mentioned here) are provided on your floor. Please read the operating instruction posted on them.
 - Please read the operating instructions on the body of the fire extinguisher provided in your floor.
 - Nearest exit from your flat is shown in this plan (plan to be provided here).
 - Assemble on the ground floor at the location indicated on the following plan. For clarification, contact the fire fighter or Deputy Safety Director. Plan of assembly point in ground floor to be provided here.
- (b) For personal and collective safety, notify the fire fighter/Deputy Safety Director in case.
- Exit route and/or door are obstructed by dumping of boxes or such other loose materials.
 - Staircase door, lift lobby doors do not close automatically or completely.
 - Push button fire alarm or fire extinguisher are obstructed or damaged or seem to be out of order.
- (c) If you discover a Fire
- Break the glass and push the button of the nearest fire alarm and call the fire service.
 - With assistance from the floor fire fighter if needed, fight fire with the in-built facilities on your floor.
 - Evacuate, if so instructed by the fire fighter
- (d) When you hear Evacuation Instructions
- Immediately leave the floor taking the nearest staircase.
 - Report to your fire fighter on reaching the predetermined assembly point outside the building.
 - Try not to use lifts.
 - Avoid going to cloak room.
 - Refrain from running or shouting, do not get panicked.
 - Do not waste a moment collecting personal belongings.
 - Keep the lift lobby and staircase doors shut.

A.11 Bangla Text of Instructions (বাংলায় নির্দেশাবলী)**(ক) নিরাপত্তাই সর্বোচ্চে**

- ভবনের প্রতি তলায় চাপ বোতাম বিশিষ্ট অগ্নি বিপদ সংকেত যন্ত্র দেয়া আছে। ব্যবহারের পূর্বে যন্ত্রের গায়ে মুদ্রিত নির্দেশাবলী পড়ুন।
- অগ্নিনির্বাপণ যন্ত্র ব্যবহারের পূর্বে অনুগ্রহ করে যন্ত্রের গায়ে মুদ্রিত নির্দেশাবলী পড়ুন।
- ভবনের যে স্থানে আপনি অবস্থান করছেন সেখান থেকে নির্গমনের নিকটতম/সহজতম পথ খুঁজে পেতে নির্গমন নকশা অনুসরণ করুন।
- নির্গমনের সুবিধার্থে ভবনের নিচতলায় নির্গমন নকশা নির্দেশিত স্থানে সমবেত হউন ও অগ্নিনির্বাপণ কর্মীর নির্দেশনা অনুসরণ করুন।

(খ) আপনার ব্যক্তিগত ও সামগ্রিক নিরাপত্তার স্বার্থে নিম্নে উল্লিখিত বিষয়ে অগ্নিনির্বাপক কর্মীকে অবহিত করুন

- জরুরী নির্গমন পথে কোন প্রকার বাধা থাকলে।
- সিঁড়ি ঘরের দরজা, লিফট লবির দরজা সম্পূর্ণভাবে বা স্বয়ংক্রিয়ভাবে বন্ধ না হলে।
- অগ্নিনির্বাপণ বিপদ সংকেত যন্ত্র ও অগ্নিনির্বাপণ যন্ত্র অকেজো বা ব্যবহার উপযোগী না থাকলে।

(গ) আগুনের উৎস খুঁজে পেলো

- বিপদ সংকেত যন্ত্রের কাঁচের আবরণ ভেঙ্গে ফেলুন, বোতামে চাপ দিন এবং ফায়ার সার্ভিসে খবর দিন।
- ভবনে রক্ষিত অগ্নি নির্বাপক যন্ত্রের সাহায্যে অগ্নি নির্বাপণে সহায়তা করুন।
- অগ্নিনির্বাপণ কর্মীর নির্দেশনা মেনে ভবন ত্যাগ করুন।

(ঘ) ভবন ত্যাগের নির্দেশনা পেলো

- নিকটতম সিঁড়ি দিয়ে দ্রুত ভবন ত্যাগ করুন।
- ভবনের বাইরে অবস্থিত নির্ধারিত সমাবেশস্থলে অগ্নিনির্বাপণ কর্মীকে আপনার উপস্থিতি অবহিত করুন।
- অগ্নিকাণ্ডের সময় লিফট ব্যবহার করবেন না।
- অগ্নিকাণ্ডের সময় ভীতসন্ত্রস্ত হয়ে অহেতুক দৌড়াদৌড়ি বা চিৎকার করবেন না।
- ব্যক্তিগত জিনিস সংগ্রহের জন্য সময় নষ্ট করবেন না।
- সিঁড়ি ঘরের দরজা, লিফট লবির দরজা বন্ধ রাখুন।
- প্রসাধন কক্ষ ব্যবহার করা থেকে বিরত থাকুন।
- গুজবে কান দেবেন না, গুজব ছড়াবেন না।

PART IV
Appendix B
Fire Protection Considerations For Venting In
Industrial And Storage Buildings

B.1 Scope

B.1.1 This Appendix covers venting requirements in industrial buildings. Provisions contained herein shall be applicable to factory and storage facilities requiring large floor areas without dividing walls and enclosures.

B.1.2 This Appendix shall not apply to ventilation designed for personnel comfort, commercial cooking operation, regulating odor or humidity in toilet and bathing facilities, to regulate cooling equipment.

B.1.3 This Appendix shall apply to fire and smoke of two criteria: (a) Fire or smoke layer that does not enhance the burning rate and (b) Deflagration.

B.2 Venting of Fire And Smoke That Does Not Enhance the Burning Rate

B.2.1 Determination of precise venting requirements is difficult, as variables like rate of combustion, composition of the combustion product, shape, size and packaging of the combustible materials as well the size, height and disposition of the stacks of materials are involved with it.

B.2.2 Vent system designs shall be computed by calculating the vent area required to achieve a mass rate of flow through the vent that equals the mass rate of smoke production.

B.2.3 Venting devices are to be so designed and installed that they operate automatically at the earliest sign of fire or smoke.

B.2.4 The smoke and fire venting system shall be so designed and installed as to keep the temperature of the combustion product as low as possible, preferably below 150°C.

B.2.5 To achieve full efficiency in vents total area of all vents must be more than the inlet area for cold air. Ideally the inlets should be as close to the ground as possible.

B.2.6 The area of unit vent shall not exceed $2d^2$, where d is the design depth of the smoke layer. For vents with length to width ratio more than two, the width shall not exceed the design depth of the smoke layer.

B.2.7 The center-to-center spacing of vents within a curtained area shall not exceed $2.8 H$, where H is the ceiling height. For different shape of the roof the ceiling height can be calculated as per provision of NFPA 204.

B.2.8 The spacing of vents shall be such that the horizontal distance from any point on a wall or draft curtain to the center of the nearest vent, within a curtained area does not exceed $1.4 H$.

B.2.9 The total vent area per curtained area shall be sized to meet the design objectives and the performance objectives relative to the design fire or smoke, determined in accordance with NFPA 204.

B.2.10 The design of venting for sprinkled building shall be based on performance analysis acceptable to the authority having jurisdiction, demonstrating that the established objectives are met.

B.2.11 Smoke and heat venting systems and mechanical exhaust systems shall be inspected and maintained in accordance with NFPA 204.

B.2.12 Venting systems are complement to fire extinguishing system. Where automatic sprinklers are installed as fire extinguishing system, the sprinklers shall operate before the vent system comes into operation.

B.2.13 In industrial buildings exterior wall windows alone shall not be accepted as satisfactory means of venting, but may be reckoned as additional means of venting when located close to the eaves and are provided with ordinary glass or movable section arranged for both manual and automatic operation.

B.2.14 Vents shall be automatic in operation unless where designed specifically for both manual and automatic operation.

B.2.15 Release mechanism of vent closure shall be simple in operation and shall not be dependent on electric power.

B.2.16 The automatic operation of vents can be achieved by actuation of fusible links or other heat or smoke detectors or by interlacing with the operation of sprinkler system or any other automatic fire extinguishing system covering the area. The vents can be so designed as to open by counterweights utilizing the force of gravity or spring loaded level following its release.

B.2.17 When vents and automatic sprinklers where installed together, sprinkler shall go into operation first before vents open, in order to avoid delay in sprinkler operation.

B.2.18 Materials used in hinges, hatches and other related parts in vents shall be noncorrosive in nature for long trouble free operation.

B.2.19 Vents shall be properly sited, at the highest point in each area to be covered.

B.2.20 If possible, vents shall be sited right on top of the probable risk area to be protected to ensure free and speedy removal of smoke and other combustion product.

B.2.21 Minimum vent opening shall not be less than 1250 mm in any direction.

B.2.22 Vent spacing shall be designed considering the fact that higher number of smaller vents is better than smaller number of large vents.

B.3 Deflagration Venting

B.3.1 Deflagration is the propagation of a fire or smoke at a velocity less than the sound wave. When this velocity of combustion increased beyond sound velocity then the combustion is said to be detonated and explosion occurred with the rupture of an enclosure or a container due to the increase of internal pressure from a deflagration.

B.3.2 The design of deflagration vents and vents closures necessitates consideration of many variables, only some of which have been investigated in depth. No Venting recommendations are currently available for fast-burning gases with fundamental burning velocities greater than 1.3 times that of propane, such as hydrogen. Recommendations are unavailable and no venting data have been generated that addresses condition that fast-burning gas deflagrations. The user is cautioned that fast-burning gas deflagrations can readily undergo transition to detonation.

B.3.3 Deflagration venting is provided for enclosures to minimize structural damage to the enclosure itself and to reduce the probability of damage to the other structures.

B.3.4 Venting shall be sufficient to prevent the maximum pressure that develops within the enclosure from exceeding enclosure strength.

B.3.5 The vent area shall be distributed as symmetrically and as evenly as possible.

B.3.6 The need for deflagration vents can be eliminated by the application of explosion prevention techniques described in NFPA 69.

B.3.7 The vent closure shall be designed to function as rapid as is practical. The mass of the closure shall be as low as possible to reduce the effects of inertia. The total mass of the moveable part of the vent closure assembly shall not be exceeded 12.2 kg/m².

B.3.8 When an enclosure is subdivided into compartments by walls, partitions, floors, or ceilings, then each compartment that contains a deflagration hazard should be provided with its own vent closure(s).

B.3.9 It is possible to isolate hazardous operations and equipment outside of buildings with a pressure resisting wall which will reduce risk of structural damage. Such operations and equipment may be housed in a single storey building having appropriate venting facilities and a device to absorb explosion shock from blowing through the duct back to the building.

B.3.10 Sometimes it may not be possible to house hazardous operations and equipment outside of the building, in which case the separation from other parts and equipment shall be achieved by pressure resisting walls and such units shall be ventilated outdoors. If suitable vents are integrated, external walls may be of heavy construction or of heavy panel which may be blown off easily.

B.3.11 Unobstructed vent opening is the most effective pressure release vent structures.

B.3.12 Explosion relief vents may be provided with open or unobstructed vents, louvers, roof vents, hanger type doors, building doors, windows, roof or wall panels or marble/fixed sash. Any or more than one of these may be adopted depending on individual situations and requirements.

B.3.13 Roof vents covered with weather hoods shall be as light as possible and attached lightly, so that it is easily blown off as and when an explosion occurs.

B.3.14 Doors and windows used as explosion vents shall be so fixed as to open outward. Doors shall be fitted with friction, spring or magnetic, latches that function automatically at the slight increase in internal pressure.

B.3.15 Placed at the top or bottom, the hinged or projected movable sash shall be equipped with latch or friction device to prevent accidental opening due to wind action or intrusion. Such latches or locks shall be well maintained.

B.3.16 Venting shall be so planned as to prevent injury to inmates and damage to enclosure. In populated locations, substantial ducts or diverts shall be provided to channelize the blast towards a pre-determined direction.

B.3.17 If explosion are probable within the duct, they shall be equipped with diaphragm to rupture at predetermined locations. The duct system shall not be physically connected to more than one collector.

B.3.18 Skylight with moveable sash that opens outward or fixed sash having panes of glass or plastic that blow out readily under pressure from within can be used to supplement wall vents or windows, provided their resistance to opening or displacement may be kept as low as possible consistent with structural requirement of the building.

B.3.19 For equivalent explosion pressure release, larger closed vents will be required compared to open vents.

B.3.20 As far as possible hazardous areas shall be segregated by means of fire walls or party walls to prevent spread of fire.

PART IV
Appendix C
Selection and Sitting of Fire Detection System

C.1 General

This Appendix provides information for selection and sitting of equipment for fire detection in buildings.

C.2 Choice of Fire Detectors

Fire detectors may respond to any one manifestation of combustions such as heat generation, smoke and flames.

Smoke detectors are not naturally suitable in places where the production process produces smokes.

Application of flame detectors are restricted due to the fact that all combustions do not necessarily accompany flame and that clear line of sight is desirable as radiation from flames travel in straight lines for actuation of sensitive element.

No single detector is able to meet the need of all types of fires and all types of occupancies. As such, based on needs arising out of various situations and occupancies, judicious selection is extremely important for the reduction of fire hazards.

C.2.1 Heat Detectors

"Point" or "Spot" type detectors are actuated by heat at layer adjacent to it over a limited area. "Line" type detectors are sensitive to the effect produced by heated gas along any portion of the detector line. Both the types operate on two broad principles: one, the heat sensitive elements is actuated by temperature rising beyond a predetermined level; while the second system is actuated by predetermined rate of rise of temperature.

C.2.2 Flame Detectors

Flame detectors are sensitive to radiation emitted by flames. Since heat, smoke and flame are produced during a fire, detectors responding to all these are accepted as general purpose detectors.

Fixed temperature heat detectors are suitable for use where ambient temperatures are high and or may rise and fall rapidly over a short period.

C.2.3 Rate of Rise Heat Detectors

These are suitable for use where ambient temperatures are low and/or may rise over a wide range slowly. Abnormally sharp rise in temperature during a fire actuates this alarm. As such it cannot be used with confidence where ambient temperatures reaches in the neighborhood of 40°C, but are best used where ambient temperatures are in the range of about 40°C.

C.2.4 Smoke Detectors

Three types of smoke detectors are commonly used. First type is actuated by absorption or scattering of visible or near-visible light by combustion product and known as "optical detector". The second type is actuated by the production on ionization current within the detector and referred to as "ionization detector". The third type is sensitive to carbon monoxide or other products of combustion and is known as "chemically sensitive detector". In general, these should be used at places where ambient temperature varies between 0° to 35°C.

C.2.4.1 Optical smoke detectors

Invisible smoke from a clear burning shall not actuate such detectors. But they respond quickly where smoke is optically dense and as such suitable for use in dust free clean atmosphere. Over a period of time, due to dust and dirt, the sensitive surface of photo sensitive element and/or executor lamp of optical detectors may loss its efficiency and as such optical detectors should be cleaned and maintained regularly.

C.2.4.2 Ionization chamber smoke detectors

These responds quickly to invisible smoke of clear burning, but may not respond to fire producing dense smoke. These can be used in dust free, humidity controlled area. Smoke and other fumes, dust including slow accumulated and disturbed aerial dust, fiber, steam and condensation produced by normal processes and vehicle engines may cause false alarm. Warehouses exposed to fast air flows can also cause false alarm. Burning of polyvinyl chloride will not sensitize the detector in time and may provide late warning or no warning at all.

C.2.4.3 Chemically sensitive smoke detectors

Chemically coated sensitive elements react to carbon monoxide or other products of combustion present in smoke. Dust or moisture adversely affects the sensitive elements and are not very suitable for residential use.

C.3 Siting Of Detectors

Considering the prevailing weather condition of the occupancies and the problem of false alarm, the type of detectors and the area of coverage shall be decided. Area of coverage of detectors is dependent on many factors. The following aspects shall be taken into considerations in the design of detectors.

- Various forms of overhead heating
- Exhaust air from air cooling equipment blowing out into the room or factory area
- Deep beams
- Roofs and ceiling of unusual shape
- Building with ground areas above 10 m and up to 30 m in height
- Staircases
- Canteen and Restaurants
- Plant Rooms
- Ambulant air currents

PART V
Chapter 1
Scope and Definitions

1.1 Scope

This Part specifies the minimum requirements of materials to be complied with in buildings and works under the provisions of the Code.

For each of the building materials the applicable standard specifications and test methods are listed. All materials shall conform to these Standards.

The list of standards given in this Part of the Code would be augmented from time to time by amendments, revisions and additions of which the Authority shall take cognizance. The latest version of a specification shall, as far as practicable, be applied in order to fulfil the requirements of this Part.

In view of the limited number of Bangladesh Standards (BDS) for building materials available at the present time, a number of standards of other countries have been referenced in this Code as applicable standards. As more standards of BDS regarding building materials become available and adopted by amendment of this Code, they shall supplement and/or replace the relevant standards listed in this Part.

1.2 Terminology

This Section provides an alphabetical list of the terms used in and applicable to this Part of the Code. In case of any conflict or contradiction between a definition given in this Section and that in Part 1, the meaning provided in this Part shall govern for interpretation of the provisions of this Part.

ACTUAL DIMENSIONS	Measured dimensions of a designated item.
ADMIXTURE	Material other than water, aggregate, or hydraulic cement used as an ingredient of concrete and added to concrete before or during its mixing to modify its properties.
AGGREGATE	Granular material, such as sand, gravel, crushed stone, crushed brick and iron blast-furnace slag, when used with a cementing medium that forms hydraulic cement concrete or mortar.
AGGREGATE, LIGHT WEIGHT	Aggregate with a dry, loose weight of 11.25 kN/m ³ or less.

CONCRETE	A mixture of Portland cement or any other hydraulic cement, fine aggregate, coarse aggregate and water, with or without admixtures.
CONCRETE, PLAIN	Concrete that does not conform to the definition of reinforced concrete.
CONCRETE, PRECAST	Plain or reinforced concrete element cast separately before they are fixed in position.
CONCRETE, PRESTRESSED	Reinforced concrete in which internal stresses have been introduced to reduce potential tensile stresses in concrete resulting from loads.
CONCRETE, REINFORCED	Concrete containing adequate reinforcement, prestressed or non-prestressed, and designed on the assumption that the two materials act together in resisting forces.
FIBRE BOARD	A fibre-felted, homogenous panel made from lignocellulosic fibres (usually wood or cane) and having a unit weight between 1.6 kN/m ³ and 5 kN/m ³ .
HARD BOARD	A fibre-felted homogenous panel made of lignocellulosic fibres consolidated under heat and pressure in a hot press to a density of 4.9 kN/m ³ or above.
MASONRY UNIT	Brick, tile, stone, glass-block or concrete-block used in masonry constructions.
MASONRY UNIT, GROUTED HOLLOW	Form of grouted masonry construction in which certain designated cells of hollow units are continuously filled with grout.
MASONRY UNIT, HOLLOW	A masonry unit whose net cross-sectional area in every plane parallel to the bearing surface is less than 75 percent of the gross cross-sectional area in the same plane.
MASONRY UNIT, SOLID	A masonry unit whose net cross-sectional area in every plane parallel to the bearing surface is 75 percent or more of the gross cross-sectional area in the same plane.
NOMINAL DIMENSIONS	Nominal dimensions of masonry units are equal to their specified dimensions plus the thickness of the joint with which the unit is laid.

PARTICLE BOARD	A manufactured panel product consisting of particles of wood or combinations of wood particles and wood fibres cemented together with synthetic resins or other suitable bonding system by an appropriate bonding process.
PLYWOOD	A built-up panel of laminated veneers.
REINFORCED MASONRY	Form of masonry construction in which reinforcement acting in conjunction with the masonry is used to resist designed forces.
REINFORCEMENT	Reinforcing bars, plain or deformed, excluding prestressing tendons, bar and rod mats, welded smooth wire fabric and welded deformed wire fabric used in concrete.
REINFORCEMENT, DEFORMED	Deformed reinforcing bars, bar and rod mats, deformed wire, welded smooth wire fabric and welded deformed wire fabric.
REINFORCEMENT, PLAIN	Reinforcement that does not conform to definition of deformed reinforcement.
REINFORCEMENT, SPIRAL	Continuously wound reinforcement in the form of a cylindrical helix.
STIRRUP	Reinforcement used to resist shear and torsion stresses in structural member; typically bars, wires, or welded wire fabric (smooth or deformed) bent into L, U or rectangular shapes and located perpendicular to or at an angle to longitudinal reinforcement. (The term "Stirrup" is usually applied to lateral reinforcement in flexural members and the term "ties" to those in compression members).
STRUCTURAL GLUED LAMINATED TIMBER	Any member comprising an assembly of laminations of lumber in which the grain of all laminations is approximately parallel longitudinally in which the laminations are bonded with adhesives.
TENDON	Steel element such as wire, cable, bar, rod or strand, or a bundle of such elements, used to impart prestress to concrete.
TIE	A loop of reinforcing bar or wire enclosing longitudinal reinforcement.
YIELD STRENGTH	The stress at which plastic deformation takes place under constant or reduced load.

PART V
Chapter 2
Building Materials

2.1 General

Materials used for the construction of buildings shall conform to standard specifications listed in this Part of the Code. Any deviation from the type design or architectural detail from those specified in these standards may be accepted by the Building Official as long as the materials standards specified therein are conformed with.

2.1.1 New or Alternative Materials

The provisions of this Part are not intended to prevent the use of any new and alternative materials. Any such material may be approved provided it is shown to be satisfactory for the purpose intended and at least equivalent of that required in this Part in quality, strength, effectiveness, fire resistivity, durability, safety, maintenance and compatibility.

Approval in writing shall be obtained by the owner or his agent before any new, alternative or equivalent materials are used. The Building Official shall base such approval on the principle set forth above and shall require that specified tests be made as per Sec 2.1.4 or sufficient evidence or proof be submitted, at the expense of the owner or his agent, to substantiate any claim for the proposed material.

2.1.2 Used Materials

The provisions of this Part do not preclude the use of used or reclaimed materials provided such materials meet the applicable requirements as for new materials for their intended use.

2.1.3 Storage of Materials

All building materials shall be stored at the building site(s) in such a way as to prevent deterioration or the loss or impairment of their structural and other essential properties (Part 7 of this Code).

2.1.4 Methods of Test

Every test of material required in this Part, or by the Building Official, for the control of quality and for the fulfillment of design and specification requirements, shall be carried out in accordance with a standard method of test issued by the Bangladesh Standards and Testing Institution (BSTI). In the absence of Bangladesh Standards, the Building Official shall determine the test procedures. Laboratory tests shall be conducted by recognized laboratories acceptable to the Building Official.

If, in the opinion of the Building Official, there is insufficient evidence of compliance with any of the provisions of the Code or there is evidence that any material or construction does not conform to the requirements of this Code, the Building Official may require tests to be performed as proof of compliance. The cost of any such test shall be borne by the owner.

The manufacturer or supplier shall satisfy himself that the materials conform to the relevant standards and if requested shall furnish a certificate or guarantee to this effect.

2.2 Masonry

2.2.1 Aggregates

Aggregates for masonry shall conform to the standards listed as follows: ASTM C144 Aggregates for Masonry Mortar; ASTM C404 Aggregates for Masonry Grout; ASTM C331 Lightweight Aggregates for Concrete Masonry Units (the applicable Standards for masonry are listed at the end of this Section).

2.2.2 Cement

Cement for masonry shall conform to the standards listed as follows: BDS EN 197-1: 2003 Cement Part-1 Composition, specifications and conformity criteria for common cements; or ASTM C150/C150M Portland Cement; ASTM C91 Masonry Cement; ASTM C595/C595M Blended Hydraulic Cements.

2.2.3 Lime

Limes for masonry shall conform to the standards listed as follows: ASTM C5, Quicklime for Structural Purposes; ASTM C207, Hydrated Lime for Masonry Purposes.

2.2.4 Masonry Units

- (a) Clay: Masonry units of clay (or shale) shall conform to the standards listed as follows: BDS 208: 2009, Common building clay bricks; BDS 1249:1989, Acid resistant bricks; BDS 1250: 1990, Burnt clay facing bricks; BDS 1263: 1990, Burnt clay hollow bricks for walls and partitions; BDS 1264 : 1990, Glossary of terms relating to structural clay products; BDS 1432: 1993, Burnt clay perforated building bricks; BDS 1803: 2008, Specification for hollow clay bricks and blocks; ASTM C34 Structural Clay Load-Bearing Wall Tile; ASTM C212 Structural Clay Facing Tile; ASTM C56 Structural Clay Non-Load-Bearing Tile; and IS 7556 Burnt clay jallies.

(b) Concrete: Concrete masonry units shall conform to the standards listed as follows :

BDS EN 771-3	Specification for masonry units-Part: 3 Aggregate concrete masonry units (dense and lightweight aggregates).
BDS EN 772-1	Methods of test for masonry units-Part 1: Determination of compressive strength.
BDS EN 772-2	Methods of test for masonry units-Part 2: Determination of percentage area of voids in masonry units (by paper indentation).
BDS EN 772-6	Methods of test for masonry units-Part 6: Determination of bending tensile strength of aggregate concrete masonry units.
BDS EN 772-11	Methods of test for masonry units-Part 11: Determination of water absorption of aggregate concrete, autoclaved aerated concrete, manufactured stone and natural stone masonry units due to capillary action and the initial rate of water absorption of clay masonry units.
BDS EN 772-13	Methods of test for masonry units-Part 13: Determination of net and gross dry density of masonry units (except for natural stone).
BDS EN 772-14	Methods of test for masonry units-Part 14: Determination of moisture movement of aggregate concrete and manufactured stone masonry units.
BDS EN 772-16	Methods of test for masonry units-Part 16: Determination of dimensions.
BDS EN 772-20	Methods of test for masonry units-Part 20: Determination of flatness of faces of masonry units.
BDS EN 1052-3	Methods of test for masonry-Part 3: Determination of initial shear strength BDS EN 1745: 2009 Masonry and masonry products-Methods for determining design thermal values.
ASTM C55	Concrete Building Bricks.
ASTM C90	Specification for Load-Bearing Concrete Masonry Units.
ASTM C129	Non-Load Bearing Units.

(c) Others

Calcium Silicate	Calcium Silicate Face Brick (Sand-Lime Brick) shall conform to ASTM C73 Standard Specification.
Glazed Masonry Units	Glazed Masonry building units shall conform to the standards listed as follows: ASTM C126, Ceramic-Glazed Structural Clay Facing Tile, Facing Brick, and Solid Masonry Units; or ASTM C744 Prefaced Concrete and Calcium Silicate Masonry Units.
Glass Block	Glass block may be solid or hollow and contain inserts; all mortar contact surfaces shall be treated to ensure adhesion between mortar and glass.
Un-burnt Clay Masonry Units	Masonry of un-burnt clay units including cement stabilized and lime stabilized blocks shall not be used, in any building more than one storey in height.
Architectural Terra Cotta	All architectural terra cotta units shall be formed with a strong homogeneous body of hard-burnt weather-resistant clay which gives off a sharp metallic ring when struck. All units shall be formed to engage securely with and anchor to the structural frame or masonry wall.
Natural Stone	Natural stone for masonry shall be sound and free from loose friable inclusions. Natural stone shall have the strength and fire resistance required for the intended use.
Cast Stone	All cast stone shall be fabricated of concrete or other approved materials of required strength, durability and fire resistance for the intended use and shall be reinforced where necessary.
AAC Masonry	AAC (Autoclaved Aerated Concrete) masonry units shall conform to ASTM C1386 for the strength class specified.
Ceramic tile	Ceramic tile shall be as defined in, and shall conform to the requirements of ANSI A137.1.
Second Hand Units	Second hand masonry units shall not be used unless the units conform to the requirements for new units. The units shall be of whole, sound material and be free from cracks and other defects that would interfere with proper laying or use. All old mortar shall be cleaned from the units before reuse.

2.2.5 Mortar

Mortar shall consist of a mixture of cementitious material and aggregates to which sufficient water and approved additives, if any, have been added to achieve a workable, plastic consistency. Cementitious materials for mortar shall be one or more of the following: lime, masonry cement, Portland cement and mortar cement. Mortar for masonry construction other than the installation of ceramic tile shall conform to the requirements of BDS 1303: 1990 Chemical resistant mortars; BDS 1304:1990 Methods of test for chemical resistant mortars; ASTM C270, Mortar for Unit Masonry.

2.2.6 Grout

Grout shall consist of a mixture of cementitious materials and aggregates to which water has been added such that the mixture will flow without segregation of the constituents. Cementitious materials for grout shall be one or both of the following: Lime and Portland cement. Grout shall have a minimum compressive strength of 13 MPa. Grout used in reinforced and unreinforced masonry construction shall conform to the requirements of ASTM C476 Grout for Masonry.

2.2.7 Mortar for Ceramic Wall and Floor Tile

Portland cement mortars for installing ceramic wall and floor tile shall comply with ANSI A 108.1-2005 listed in Sec 2.2.11 and be of the composition specified in Table 5.2.1.

2.2.7.1 Dry-set leveling cement mortars

Premixed prepared leveling cement mortars, which require only the addition of water and are used in the installation of ceramic tile, shall comply with ANSI A118.1. The shear bond strength for tile set in such mortar shall be as required in accordance with ANSI A118.1. Tile set in dry-set Portland cement mortar shall be installed in accordance with ANSI A108.5.

2.2.7.2 Latex-modified leveling cement mortar

Latex-modified leveling cement thin-set mortars in which latex is added to dry-set mortar as a replacement for all or Part of the gauging water that are used for the installation of ceramic tile shall comply with ANSI A118.4. Tile set in latex-modified leveling cement shall be installed in accordance with ANSI A108.5.

2.2.7.3 Epoxy mortar

Ceramic tile set and grouted with chemical-resistant epoxy shall comply with ANSI A118.3. Tile set and grouted with epoxy shall be installed in accordance with ANSI A108.6.

2.2.7.4 Furan mortar and grout

Chemical-resistant furan mortar and grout that are used to install ceramic tile shall comply with ANSI A118.5. Tile set and grouted with furan shall be installed in accordance with ANSI A108.8.

2.2.7.5 Modified epoxy-emulsion mortar and grout

Modified epoxy-emulsion mortar and grout that are used to install ceramic tile shall comply with ANSI A118.8. Tile set and grouted with modified epoxy-emulsion mortar and grout shall be installed in accordance with ANSI A108.9.

2.2.7.6 Organic adhesives

Water-resistant organic adhesives used for the installation of ceramic tile shall comply with ANSI A136.1. The shear bond strength after water immersion shall not be less than 275 kPa (40 psi) for Type I adhesive and not less than 138 kPa (20 psi) for Type II adhesive when tested in accordance with ANSI A136.1. Tile set in organic adhesives shall be installed in accordance with ANSI A108.4.

2.2.7.7 Portland cement grouts

Portland cement grouts used for the installation of ceramic tile shall comply with ANSI A118.6. Portland cement grouts for tile work shall be installed in accordance with ANSI A108.10.

2.2.7.8 Mortar for Autoclaved Aerated Concrete (AAC) masonry

Thin-bed mortar for AAC masonry shall comply with Article 2.1 C.1 of TMS 602/ACI 530.1/ASCE 6. Mortar used for the leveling courses of AAC masonry shall comply with Article 2.1 C.2 of TMS 602/ACI 530.1/ASCE 6.

2.2.8 Metal Ties and Anchors

Metal ties and anchors shall conform to the standards listed as follows: ASTM A82/A82M, Wire Anchor and Ties; and ASTM A1008/A1008M, Sheet Metal Anchors and Ties.

Table 5.2.1: Ceramic Tile Mortar Compositions

Walls	Scratch coat	1 cement, 0.20 hydrated lime*, 4 dry or 5 damp sand
	Setting bed and leveling coat	1 cement, 0.50 hydrated lime, 5 damp sand to 1 cement, 1 hydrated lime; 7 damp sand
Floors	Setting bed	1 cement; 0.10 hydrated lime; 5 dry or 6 damp sand; or 1 cement; 5 dry or 6 damp sand
Ceilings	Scratch coat and sand bed	1 cement; 0.50 hydrated lime; 2.50 dry sand or 3 damp sand

* Lime may be excluded from the mortar if trial mixes indicate that the desired workability and performance are achieved without lime.

2.2.9 Reinforcement

Reinforcement in masonry shall conform to the standards listed as follows: ASTM A82/A82M, Cold Drawn Steel Wire for Concrete Reinforcement; ASTM A615/A615M, Deformed and Plain Billet Steel Bars; ASTM A996/A996M, Rail-Steel Deformed and Plain Bars; ASTM A996/A996M, Axle-Steel Deformed and Plain Bars; ASTM A706/A706M, Low-Alloy Steel Deformed Bars; ASTM A767/A767M, Zinc-Coated (Galvanized) Steel Bars; and ASTM A775/A775M, Epoxy-Coated Reinforcing Steel Bars.

2.2.10 Water

Water used in mortar or grout shall be clean and free of deleterious amounts of acid, alkalis or organic material or other harmful substances.

2.2.11 Applicable Standards for Masonry

The applicable standards for Masonry are listed below:

- | | |
|--------------|---|
| BDS EN 197-1 | Cement Part-1 Composition, Specifications and Conformity Criteria for Common Cements. |
| BDS 208 | Specification for Common Building Clay Bricks : Specifies the dimensions, quality and strength of common burnt clay bricks, methods of sampling, testing etc. |

BDS 238	Fire Clay Refractory Bricks and Shapes for General Purposes: This Standard specifies the requirements for fireclay refractory bricks and shapes meant for general purpose; the products are classified in four grades according to the duty for which they are suitable.
BDS 1249	Acid Resistant Bricks: It specifies the requirements for acid-resistant bricks, dimensions, tolerances, test etc.
BDS 1250	Burnt Clay Facing Bricks: It specifies the dimensions, quality and strength of burnt clay facing bricks used in building and other structure, physical requirements etc.
BDS 1263	Burnt Clay Hollow Bricks for Walls and Partitions: It covers the dimensions, quality and strength for hollow bricks made from burnt clay and having perforations through and at right angle to the bearing surface tests.
BDS 1264	Glossary of Terms Relating to Structural Clay Products: It covers the definition of common terms applicable to structural clay products, used in building and civil engineering works.
BDS 1432	Burnt Clay Perforated Building Bricks: Specifies the requirements in regard to dimensions, perforations, quality, strength and also for quality of surface in case of special grade for facing bricks of perforated burnt clay building bricks for use in walls and partitions.
BDS 1433	Dimensions quantities in general construction work: Specifies the various dimensional values in SI units used in general construction work.
BDS 1803	Specification for hollow clay bricks and blocks.
BDS EN 1338	Concrete paving blocks-Requirements and test methods.
BDS EN 1339	Concrete paving flags-Requirements and test methods.
BDS EN 1340	Concrete kerb units-Requirements and test methods.
BDS EN 13369	Common rules for precast concrete products.
BDS EN 771-3	Specification for masonry units Part 3: Aggregate concrete masonry units (dense and lightweight aggregates).
BDS EN 772-1	Methods of test for masonry units Part 1: Determination of compressive strength.

BDS EN 772-2	Methods of test for masonry units Part 2: Determination of percentage area of voids in masonry units (by paper indentation).
BDS EN 772-6	Methods of test for masonry units Part 6: Determination of bending tensile strength of aggregate concrete masonry units.
BDS EN 772-11	Methods of test for masonry units Part 11: Determination of water absorption of aggregate concrete, autoclaved aerated concrete, manufactured stone and natural stone masonry units due to capillary action and the initial rate of water absorption of clay masonry units.
BDS EN 772-13	Methods of test for masonry units Part 13: Determination of net and gross dry density of masonry units (except for natural stone).
BDS EN 772-14	Methods of test for masonry units Part 14: Determination of moisture movement of aggregate concrete and manufactured stone masonry units.
BDS EN 772-16	Methods of test for masonry units Part 16: Determination of dimensions.
BDS EN 772-20	Methods of test for masonry units Part 20: Determination of flatness of faces of masonry units.
BDS EN 1052-3	Methods of test for masonry Part 3: Determination of initial shear strength.
BDS EN 1745	Masonry and masonry products: Methods for determining design thermal values.
ANSI A108.1A	Installation of Ceramic Tile in the Wet-Set Method, with Portland Cement Mortar.
ANSI A108.1B	Installation of Ceramic Tile, Quarry Tile on a Cured Portland Cement Mortar Setting Bed with Dry-set or Latex-Portland Mortar.
ANSI A108.1	Specifications for the Installation of Ceramic Tile with Portland Cement Mortar.
ASTM A82/ A82M	Specification for Steel Wire, Plain, for Concrete Reinforcement.

ASTM A1008/ A1008M	Standard Specification for Steel, Sheet, Cold-Rolled, Carbon, Structural, High-Strength Low-Alloy, High-Strength Low-Alloy with Improved Formability, Solution Hardened, and Bake Hardenable.
ASTM A615/A615M	Standard Specification for Deformed and Plain Carbon-Steel Bars for Concrete Reinforcement.
ASTM A996/A996M	Standard Specification for Rail-Steel and Axle-Steel Deformed Bars for Concrete Reinforcement.
ASTM A706/A706M	Standard Specification for Low-Alloy Steel Deformed and Plain Bars for Concrete Reinforcement.
ASTM A183	Standard Specification for Carbon Steel Track Bolts and Nuts.
ASTM A775/A775M	Standard Specification for Epoxy-Coated Steel Reinforcing Bars.
ASTM C5	Standard Specification for Quicklime for Structural Purposes.
ASTM C34	Standard Specification for Structural Clay Load-Bearing Wall Tile.
ASTM C55	Standard Specification for Concrete Building Brick.
ASTM C56	Standard Specification for Structural Clay Non load bearing Tile.
ASTM C73	Standard Specification for Calcium Silicate Brick (Sand-Lime Brick).
ASTM C90	Standard Specification for Load bearing Concrete Masonry Units.
ASTM C91	Standard Specification for Masonry Cement.
ASTM C126	Standard Specification for Ceramic Glazed Structural Clay Facing Tile, Facing Brick, and Solid Masonry Units.
ASTM C129	Standard Specification for Non-load bearing Concrete Masonry Units.
ASTM C144	Standard Specification for Aggregate for Masonry Mortar.
ASTM C90	Standard Specification for Load bearing Concrete Masonry Units.
ASTM C150/ C150M	Standard Specification for Portland Cement.

ASTM C207	Standard Specification for Hydrated Lime for Masonry Purposes.
ASTM C212	Standard Specification for Structural Clay Facing Tile.
ASTM C270	Standard Specification for Mortar for Unit Masonry.
ASTM C331	Standard Specification for Lightweight Aggregates for Concrete Masonry Units.
ASTM C404	Standard Specification for Aggregates for Masonry Grout.
ASTM C476	Standard Specification for Grout for Masonry.
ASTM C595/C595M	Standard Specification for Blended Hydraulic Cements.
ASTM C744	Standard Specification for Prefaced Concrete and Calcium Silicate Masonry Units.

2.3 Cement and Concrete

2.3.1 General

Materials used to produce concrete, and admixtures used for concrete shall comply with the requirements of this Section and those of Chapter 5 Part 6 of this Code.

2.3.2 Aggregates

Concrete aggregates shall conform to the following standards:

BDS 243: 1963, Coarse and Fine Aggregates from Natural Sources for Concrete; ASTM C33/C33M Concrete Aggregates; ASTM C330/C330M Lightweight Aggregates for Structural Concrete; ASTM C637 Aggregates for Radiation-Shielding Concrete; ASTM C332 Lightweight Aggregate for Insulating Concrete; IS: 9142 Artificial lightweight aggregates for concrete masonry units.

2.3.2.1 Special tests

Aggregates failing to meet the specifications listed in Sec 2.4.2 shall not be used unless it is shown by special test or actual service experience to produce concrete of adequate strength and durability and approved by the Building Official.

2.3.2.2 Nominal size

Nominal maximum size of coarse aggregate shall not be larger than:

- One-fifth of the narrowest dimension between sides of forms; or
- One-third the depth of slabs; or
- Three fourths the minimum clear spacing between individual reinforcing bars or wires, bundles of bars, or pre-stressing tendons or ducts.

Exception:

The above limitations regarding size of coarse aggregate may be waived if, in the judgment of the Engineer, workability and methods of consolidation are such that concrete can be placed without honeycomb or voids.

2.3.3 Cement

Cement shall conform to the following standards: BDS EN 197-1:2003 Cement Part-1 Composition, specifications and conformity criteria for common cements, BDS 612 Sulphate resisting Portland cement-type A, ASTM C150/C150M Standard Specification for Portland Cement, BDS 232 Portland cement, ASTM C595/C595M Blended Hydraulic Cements, and to other such cements listed in ACI 318.

2.3.4 Water

Water used in mixing concrete shall be clean and free from injurious amounts of oils, alkalies salts, organic materials or other substances that may be deleterious to concrete or reinforcement. Water shall conform to the following standards: BDS ISO 12439:2011 Mixing water for concrete.

2.3.4.1 Chloride ions

Mixing water for pre-stressed concrete or for concrete that will contain aluminium embedment, including the portion of mixing water contributed in the form of free moisture on aggregates shall not contain deleterious amounts of chloride ion. The maximum water-soluble chloride ion concentration in concrete shall not exceed the limitations specified in Sec 5.5.3 Part 6.

2.3.4.2 Potability

Nonpotable water shall not be used in concrete unless the following are satisfied:

- (a) Selection of concrete proportions shall be based on concrete mixes using water from such source.
- (b) Mortar test cubes made with non-potable mixing water shall have 7 days and 28 days strengths equal to at least 90 percent of strengths of similar specimens made with potable water.

2.3.5 Admixtures

Admixtures to be used in concrete shall be subject to prior approval by the Building Official and shall comply with Sections 2.4.5.1 to 2.4.5.5. Admixtures shall conform following standards:

- | | |
|--------------|---|
| BDS EN 934-1 | Admixtures for Concrete, Mortar and Grout-Part 1: Common Requirements. |
| BDS EN 934-2 | Admixtures for Concrete, Mortar and Grout-Part 2: Concrete Admixtures Definitions, Requirements, Conformity, Marking and Labelling. |

2.3.5.1 Chloride

Calcium chloride or admixtures containing chloride from admixture ingredients shall not be used in prestressed concrete, concrete containing embedded aluminium in concrete cast against permanent galvanized metal forms, or in concrete exposed to severe or very severe sulphate-containing solutions (Sec 5.5.2.1 Part 6).

2.3.5.2 Standards

Air-entraining admixtures shall conform to ASTM C260 Standard Specification for Air-entraining Admixtures for Concrete. Water-reducing admixtures, retarding admixtures, accelerating admixtures, water-reducing and retarding admixtures, and water-reducing and accelerating admixtures shall conform to ASTM C494/C494M Chemical Admixtures for Concrete, or ASTM C1017/C1017M Chemical Admixtures for Use in Producing Flowing Concrete.

2.3.5.3 Pozzolanas

Fly ash (Pulverized Fuel Ash) or other Pozzolanas used as admixtures shall conform to ASTM C618 Standard Specification for Coal Fly Ash and Raw or Calcined Natural Pozzolanas for Use in Concrete.

2.3.5.4 Blast furnace slag

Ground granulated blast-furnace slag used as an admixture shall conform to ASTM C989 Standard Specification for Slag Cement for Use in Concrete and Mortars.

2.3.5.5 Pigment for coloured concrete

Pigment for integrally coloured concrete shall conform to ASTM C979 Standard Specification for Pigments for Integrally Colored Concrete.

2.3.6 Metal Reinforcement

Reinforcement and welding of reinforcement to be placed in concrete shall conform to the requirements of this Section.

- (a) Deformed Reinforcement: Deformed reinforcing bars shall conform to the following Standards; BDS ISO 6935-2:2010, Steel for the reinforcement of concrete-Part-2: Ribbed bars; Reinforcement conforming to the ASTM, Standards: A615/A615M Deformed and Plain Billet-Steel Bars; A616M, Rail-Steel Deformed and Plain Bars; A617M Axle-Steel Deformed and Plain Bars; A706M Low-Alloy Steel Deformed Bars; A767M Zinc Coated (Galvanized) Steel Bars; and A775M Epoxy-Coated Reinforcing Steel.

Deformed reinforcing bars with a specified yield strength f_y exceeding 410 MPa may be used, provided f_y shall be the stress corresponding to a strain of 0.35 percent and the bars otherwise conform to ASTM standards noted above. Fabricated deformed steel bar mats conforming to ASTM A184/A184M and deformed steel wire complying with ASTM A496/A496M may be used. Deformed wire for concrete reinforcement shall not be smaller than size D4 (nominal diameter: 5.72 mm), and for wire with a specified yield strength, f_y exceeding 410 MPa, f_y shall be the stress corresponding to a strain of 0.35 percent.

Welded deformed steel wire fabric conforming to ASTM A497/A497M may be used; for a wire with specified yield strength f_y exceeding 410 MPa, f_y shall be the stress corresponding to a strain of 0.35 percent. Welded intersections shall not be spaced farther apart than 400 mm in direction of calculated stress, except for wire fabric used as stirrups.

- (b) Plain Reinforcement: Plain reinforcement shall conform to the following BDS and ASTM Standards. BDS ISO 6935-1:2010; ASTM A615/A615M; ASTM A996/A996M and ASTM A996/A996M. Steel welded wire, fabric plain reinforcement conforming to ASTM A185/A185M may be used, except that for wire with specified yield strength f_y exceeding 410 MPa, f_y shall be the stress corresponding to a strain of 0.35 percent. Welded intersections shall not be spaced farther apart than 300 mm in direction of calculated stress, except for wire fabric used as stirrups.

Smooth steel wire conforming to ASTM A182/A182M may be used in concrete; except that for a wire with specified yield strength f_y exceeding 410 MPa, f_y shall be the stress corresponding to a strain of 0.35 percent.

- (c) Cold-worked Steel Reinforcement: Cold-worked steel high strength bars shall conform to IS 1786 or BS 4461: 1978.
- (d) Pre-stressing Tendons: Wire, strands and bars for tendons in pre-stressed concrete shall conform to BDS: 240 Plain cold drawn steel wire; ASTM A416/A416M Steel Strand Uncoated Seven-Wire Stress Relieved; ASTM A421/A421M: Uncoated Stress Relieved Steel Wire; and ASTM A722/A722M: Uncoated High-Strength Steel Bar.

Wires, strands and bars not specifically listed in the above standards may be used, provided they conform to minimum requirements of these specifications and do not have properties that make them less satisfactory than those listed.

- (e) Structural Steel, Steel Pipe or Tubing: Structural steel used with reinforcing bars in composite compression members meeting the requirements of the Code shall conform to ASTM A36/A36M Structural Steel; ASTM A242/A242M High Strength Low-Alloy Structural Steel; ASTM A572/A572M High-Strength Low-Alloy Columbium-Vanadium Steel; and ASTM A588/A588M High-Strength Low-Alloy Structural Steel.

Steel pipe or tubing for composite compression members composed of a steel-encased concrete core meeting the requirements of this Code shall conform to ASTM A53/A53M Pipe, Steel, Black and Hot Dipped Zinc Coated Welded and Seamless; ASTM A500/A500M Cold-Formed Welded and Seamless Carbon Steel Structural Tubing in Rounds and Shapes; and ASTM A501 Hot-Formed Welded and Seamless Carbon Steel Structural Tubing.

2.3.7 Applicable Standards

Materials used in concrete shall comply with the applicable standards listed below.

BDS 279	Specification for Abrasion of Coarse Aggregates by Use of Los Angeles Machine (under revision).
BDS 281	Specification for Organic Impurities in Sands for Concrete (under revision).
BDS 921	Specification for Standard Sand for Testing of Cement.
BDS 240	Specification for Plain Cold Drawn Steel Wire for Pre-stressed Concrete.
BDS 243	Specification for Coarse and Fine Aggregates from Natural Sources for Concrete.
BDS ISO 1920-8	Testing of Concrete-Part 8: Determination of Drying Shrinkage of Concrete for Samples Prepared in the Field or in the Laboratory.
BDS ISO 1920-9	Testing of Concrete-Part 9: Determination of Creep of Concrete Cylinders in Compression.
BDS ISO 1920-10	Testing of Concrete-Part 10: Determination of Static Modulus of Elasticity in Compression.
BDS ISO 22965-1	Concrete-Part 1: Methods of Specifying and Guidance for the Specifier.

BDS ISO 22965-2	Concrete-Part 2: Specification of Constituent Materials, Production of Concrete and Compliance of Concrete.
ASTM C31/C31M	Standard Practice for Making and Curing Concrete Test Specimens in the Field.
ASTM C39/C39M	Standard Test Method for Compressive Strength of Cylindrical Concrete Specimens.
ASTM C42/C42M	Standard Test Method for Obtaining and Testing Drilled Cores and Sawed Beams of Concrete.
ASTM C78	Standard Test Method for Flexural Strength of Concrete (Using Simple Beam with Third-Point Loading)
ASTM C94/C94M	Standard Specification for Ready-Mixed Concrete.
ASTM C172	Standard Practice for Sampling Freshly Mixed Concrete.
ASTM C192/C192M	Standard Practice for Making and Curing Concrete Test Specimens in the Laboratory.
ASTM C317/C317M	Standard Specification for Gypsum Concrete.
ASTM C496/C496M	Standard Test Method for Splitting Tensile Strength of Cylindrical Concrete Specimens.
ASTM C617	Standard Practice for Capping Cylindrical Concrete Specimens.
ASTM C685/C685M	Standard Specification for Concrete Made by Volumetric Batching and Continuous Mixing.
ASTM C989	Standard Specification for Slag Cement for Use in Concrete and Mortars.

2.3.8 Concrete Pipe and Precast Sections

Concrete pipes and precast sections shall conform to the Standards listed below:

BDS 1626	Concrete pipes (with and without) reinforcement.
ASTM C14M	Standard Specification for Non-reinforced Concrete Sewer, Storm Drain, and Culvert Pipe (Metric).
ASTM C76M	Standard Specification for Reinforced Concrete Culvert, Storm Drain, and Sewer Pipe (Metric).

ASTM C361M	Standard Specification for Reinforced Concrete Low-Head Pressure Pipe (Metric).
ASTM C444M	Standard Specification for Perforated Concrete Pipe (Metric).
ASTM C478M	Standard Specification for Precast Reinforced Concrete Manhole Sections (Metric).
ASTM C507M	Standard Specification for Reinforced Concrete Elliptical Culvert, Storm Drain, and Sewer Pipe (Metric).
ASTM C654M	Standard Specification for Porous Concrete Pipe (Metric).
ASTM C655M	Standard Specification for Reinforced Concrete D-Load Culvert, Storm Drain, and Sewer Pipe (Metric).
ASTM C1433M	Standard Specification for Precast Reinforced Concrete Monolithic Box Sections for Culverts, Storm Drains, and Sewers (Metric).
ASTM C858	Standard Specification for Underground Precast Concrete Utility Structures.
ASTM C891	Standard Practice for Installation of Underground Precast Concrete Utility Structures.
ASTM C913	Standard Specification for Precast Concrete Water and Wastewater Structures.
ASTM C924M	Standard Practice for Testing Concrete Pipe Sewer Lines by Low-Pressure Air Test Method (Metric).
IS 458	Specification for precast concrete pipes with and without reinforcement.
IS 784	Specification for pre-stressed concrete pipes.
IS 1916	Specification for steel cylinder pipe with concrete lining and coating.
IS 3597	Methods of test for concrete pipes.
IS 4350	Specification for concrete porous pipes for under drainage.
IS 7319	Specification for perforated concrete pipes.
IS 7322	Specification for specials for steel cylinder reinforced concrete pipes.

2.4 Pre-Stressed Concrete

2.4.1 Concrete for Pre-stressed Concrete

Cement and concrete required for pre-stressed concrete are elaborately described in Sec 2.3 of this Part. BDS and other standards for concrete as a material are also contained in the same section.

2.4.2 Steel for Pre-stressed Concrete

Steel and tendons for pre-stressed concrete along with the BDS and other standard requirements are included in Sec 2.8 of this Part.

Steel material for pre-stressed concrete shall also conform following Standards.

BDS ISO 6934-1	Steel for the prestressing of concrete-Part 1: General requirements.
BDS ISO 6934-2	Steel for the prestressing of concrete-Part 2: Cold-drawn wire.
BDS ISO 6934-3	Steel for the prestressing of concrete-Part 3: Quenched and tempered wire.
BDS ISO 6934-4	Steel for the prestressing of concrete-Part 4: Strand.
BDS ISO 6934- 5	Steel for the Prestressing of concrete-Part 5: Hot-rolled steel bars with or without subsequent processing.
BDS ISO 6935 (Part-1)	Steel for the reinforcement of concrete-Part-1: Plain bars.
BDS ISO 6935 (Part-2)	Steel for the reinforcement of concrete-Part-2: Ribbed bars.
BDS ISO 6935 (Part-3)	Steel for the reinforcement of concrete-Part-3: Welded fabric. Specifies technical requirements for factory made sheets or rolls welded fabric manufacture from steel wires or bars with diameters from 4 mm to 16 mm and designed for reinforcement in ordinary concrete structured and for non-prestressed reinforcement in prestressed concrete structures.
BDS ISO 10065	Steel bars reinforcement of concrete bend and re-bend tests.
BDS ISO 15835-1	Steel for the reinforcement of concrete-Reinforcement couplers for mechanical splices of bars-Part 1: Requirements.

BDS ISO 15835-2	Steel for the reinforcement of concrete-Reinforcement couplers for mechanical splices of bars-Part 2: Test methods.
BDS ISO 10144	Certification scheme for steel bars and wires for the reinforcement of concrete structures.
BDS ISO 15630-1	Steel for the reinforcement and Prestressing of concrete-Test methods-Part 1: Reinforcing bars, wire rod and wire.
BDS ISO 15630-2	Steel for the reinforcement and prestressing of concrete-Test methods-Part 2: Welded fabric.
BDS ISO 15630-3	Steel for the Reinforcement and prestressing of concrete-Test methods-Part 3: Prestressing steel.
BDS ISO 16020	Steel for the reinforcement and prestressing of concrete-Vocabulary.

2.5 Building Limes

2.5.1 Types of Lime

According to the degree of calcinations, slaking and setting actions and depending upon the nature and amount of foreign matters associated with, the limes are classified as: (i) High calcium, fat, rich, common or pure lime; (ii) Lean, meager or poor lime; and (iii) Hydraulic or water lime

2.5.2 Properties of Lime

A good lime should slake readily in water, dissolve in soft water, free from fuel ashes and unburnt particles and have good setting power under water.

Building limes shall comply with the following ASTM standard specifications: ASTM C206 Finishing Hydrated Lime; ASTM C207 Hydrated Lime for Masonry Purposes; ASTM C141/C141M Hydraulic Hydrated Lime for Structural Purposes; ASTM C977 Quicklime and Hydrated Lime for Soil Stabilization; and ASTM C5 Quicklime for Structural Purposes.

The following Indian Standards may also be accepted for lime concrete and testing of building limes:

IS712	Specification for building limes.
IS1624	Method of field testing of building lime.
IS 2686	Specification for cinder aggregates for use in lime concrete.

IS 3068	Specification for broken brick (burnt clay) coarse aggregates for use in lime concrete.
IS 3115	Specification for lime-based blocks.
IS 3182	Specification for broken brick (burnt clay) fine aggregates for use in lime mortar.
IS 4098	Specification for lime-pozzolana mixture.
IS 4139	Specification for sand-lime bricks.
IS 6932 (Parts I to XI)	Method of tests for building limes.
IS 10360	Specification for lime-pozzolana concrete blocks for paving.
IS 10772	Specification for quick setting lime pozzolana mixture.
IS12894	Specification for pulverized fuel ash lime bricks.

2.6 Gypsum Based Materials and Plaster

2.6.1 Gypsum Board

Gypsum wallboard, gypsum sheathing, gypsum base for gypsum veneer plaster, exterior gypsum soffit board, pre-decorated gypsum board or water resistant gypsum backing board complying with the standards listed below.

2.6.2 Gypsum Plaster

A mixture of calcined gypsum or calcined gypsum and lime and aggregate and other approved materials as specified in this Code.

2.6.3 Gypsum Veneer Plaster

Gypsum plaster applied to an approved base in one or more coats normally not exceeding 1/4 inch (6.4 mm) in total thickness.

2.6.4 Cement Plaster

A mixture of Portland or blended cement, Portland cement or blended cement and hydrated lime, masonry cement or plastic cement and aggregate and other approved materials as specified in this Code.

Gypsum building materials shall conform to the Standards listed below.

ASTM C22/C22M	Standard Specification for Gypsum.
ASTM C28/C28M	Standard Specification for Gypsum Plasters.
ASTM C35	Standard Specification for Inorganic Aggregates for Use in Gypsum Plaster.
ASTM C59/C59M	Standard Specification for Gypsum Casting Plaster and Gypsum Molding Plaster.
ASTM C317/ C317M	Standard Specification for Gypsum Concrete.
ASTM C471M	Standard Test Methods for Chemical Analysis of Gypsum and Gypsum Products.
ASTM C472	Standard Test Methods for Physical Testing of Gypsum, Gypsum Plasters and Gypsum Concrete.
ASTM C473	Standard Test Methods for Physical Testing of Gypsum Panel Products.
ASTM C474	Standard Test Methods for Joint Treatment Materials for Gypsum Board Construction.
ASTM C587	Standard Specification for Gypsum Veneer Plaster.
ASTM C1396/C1396M	Standard Specification for Gypsum Board.
IS 2849-1983	Specification for non-load bearing gypsum partition blocks (solid and hollow types).

2.7 Flooring Materials

2.7.1 General

Flooring materials are generally of two types; precast systems like tiles, bricks and cast in-situ.

2.7.2 Concrete/Terrazzo Tiles

Concrete/Terrazzo tiles shall have good abrasion and impact resistance properties. Factors such as the type of cement and the type and grading of aggregate used, influence the resistance of such tiles to chemicals including cleaning agents. Terrazzo tiles shall have a wear layer after grinding at least 6 mm composed of graded marble chipping in white, tinted or grey Portland cement on a layer of fine concrete. They may be ground

after manufacture to expose the marble aggregate and subsequently grouted. Slip resisting grits may be incorporated. These tiles shall conform to BDS EN 13748-1:2008 Terrazzo tiles-Part 1: Terrazzo tiles for internal use; BDS EN 13748-2:2008 Terrazzo tiles-Part 2: Terrazzo tiles for external use; BDS 1262: 1990 Clay flooring tiles; BDS 1248: 1989 Ceramic unglazed vitreous acid resistant tiles or IS: 1237, Specification for cement concrete flooring tile.

2.7.3 Asphalt Tiles/Flooring

Asphalt tiles/floorings are suitable for industrial flooring in areas where they will not be exposed to solvents, grease, oil, corrosive chemicals and excessive heat. Bitumen mastic for flooring shall conform to IS: 1195; IS: 8374 Bitumen Mastic, Anti-static and Electrically Conducting Grade and IS: 9510 Bitumen Mastic Acid Resisting Grade.

2.7.4 Mosaic Tiles

Mosaic tiles of a variety of shapes and sizes may be used. Thickness of the wear layer is dependent on the sizes of marble chips but shall not be less than 6 mm thick. The tiles shall be wet cured for sufficient time before laying so that their surfaces are not damaged during grinding and polishing.

2.7.5 Clay Tile

Clay floor tiles shall have sufficient strength and abrasion resistant characteristics to withstand the impact and abrasion they are likely to be subject to. When glazed earthenware tiles are used in flooring they shall conform to IS: 777 Glazed Earthenware Tiles.

2.7.6 Vinyl Tiles

The vinyl tiles shall consist of a thoroughly blended composition of thermoplastic binder, asbestos fibre, fillers and pigments. The thermoplastic binder shall consist substantially of either or both of the following:

- (a) Vinyl chloride polymer
- (b) Vinyl chloride copolymers.

The polymeric material shall be compounded with suitable plasticizers and stabilizers. The tiles may be plain, patterned or mottled. The thickness shall not be less than 1.5 mm.

2.7.7 Rubber Tiles

These tiles are composed of natural, synthetic or reclaimed rubber, or a combination of these, with reinforcing fibres, pigments, and fillers, vulcanized and molded under pressure. The tiles shall have excellent resilience and resistance to indentation, and good resistance to grease, alkali and abrasion. The thickness shall not be less than 2 mm.

2.7.8 Cast In-situ Floor Coverings

- (a) Terrazzo: Terrazzo is a marble mosaic with Portland cement matrix and is generally composed of two parts marble chips to one part Portland cement. Color pigments may be added. The thickness of terrazzo topping may vary from 13 mm to 19 mm and may be applied to green concrete of the floor or bonded with neat Portland cement, or over a sand cushion placed on the concrete floor.
- (b) Concrete: A concrete topping may be applied to a concrete structural slab before or after the base slab has hardened. Integral toppings may generally be 25 mm to 40 mm thick; independent toppings about 25 mm to 50 mm thick. Aggregate sizes shall not exceed 6 mm.

2.7.9 Other Flooring Materials

Other flooring materials i.e. bricks, natural stone, etc. showing satisfactory performance in similar situations may be allowed. Plastic flooring tile and ceramic unglazed vitreous acid resistant tiles, if used, shall conform to IS: 3464 and IS: 4357 respectively.

Flooring compositions complying with IS: 657, Materials for use in the manufacture of magnesium oxychloride flooring composition; and IS: 9197, Epoxy resin composition for floor topping may be allowed. Linoleum sheets and tiles shall conform to IS: 653.

Flooring materials shall also conform to the standards listed below.

- | | |
|----------|---|
| BDS 1248 | Ceramic unglazed vitreous acid resistant tiles seat covers the requirements for ceramic unglazed vitreous acid resistant tiles used in lying of floors & lining of tanks subjected to corrosive conditions. Manufacture, Finish, Tests etc. |
| BDS 1262 | Clay flooring tiles.

Specifies the requirements for dimensions, quality & strength for clay flooring tiles & different types of tests. |

BDS ISO 10545 - 1	Ceramic tiles, Sampling and basis for acceptance. Specifies rules for batching, sampling, inspection and acceptance/ rejection of ceramic tiles.
BDS ISO 10545 - 2	Ceramic tiles, Determination of dimensions and surface quality. Specifies methods for determining the dimensional characteristics (length, width, thickness, straightness of sides, rectangularity, and surface flatness) and the surface of ceramic tiles.
BDS ISO 10545 - 3	Ceramic tiles, Determination of water absorption, apparent porosity, apparent relative density and bulk density. Specifies methods for determining water absorption, apparent porosity, apparent relative density and bulk density of ceramic tiles.
BDS ISO 10545 - 4	Ceramic tiles, Determination of modulus of rupture and breaking strength Defines a test method for determining the modulus of rupture and breaking strength of all ceramic tiles.
BDS ISO 10545 - 5	Ceramic tiles, Determination of impact resistance by measurement of coefficient of restitution Specifies methods for determining the impact resistance of ceramic tiles by measuring the coefficient of restitution.
BDS ISO 10545 - 6	Ceramic tiles, Determination of resistance to deep abrasion for unglazed tiles.
BDS ISO 10545 - 7	Ceramic tiles, Determination of resistance to surface abrasion for glazed tiles. Specifies a method for determining the resistance to surface abrasion of all glazed ceramic tiles used for floor covering.
BDS ISO 10545 - 8	Ceramic tiles, Determination of linear thermal expansion Defines a test method for determining the coefficient of linear thermal expansion of ceramic tiles.
BDS ISO 10545 - 9	Ceramic tiles, Determination of resistance to thermal shock. Defines a test method for determining the resistance to thermal shock of all ceramic tiles under normal conditions of use.

BDS ISO 10545 - 10	Ceramic tiles, Determination of moisture expansion. Specifies a method for determining the moisture expansion of all ceramic tiles.
BDS ISO 10545 - 11	Ceramic tiles, Determination of crazing resistance for glazed tiles. Defines a test method for determining the crazing resistance of all glazed ceramic tiles except when the crazing is an inherent decorative feature of the product.
BDS ISO 10545 - 12	Ceramic tiles, Determination of frost resistance. Specifies a method for determining the frost resistance of all ceramic tiles intended for use in freezing conditions in the presence of water.
BDS ISO 10545 - 13	Ceramic tiles, Determination of chemical resistance. Specifies a test method for determining the chemical resistance of all ceramic tiles at room temperature. The method is applicable to all types of ceramic tiles.
BDS ISO 10545 - 14	Ceramic tiles, Determination of resistance to stains. Specifies a method for determining the resistance to stains of the proper surface of ceramic tiles.
BDS ISO 10545 - 15	Ceramic tiles, Determination of lead and cadmium given off by glazed tiles. Specifies a method for the determination of lead and cadmium given off by the glaze of ceramic tiles.
BDS ISO 10545 - 16	Ceramic tiles, Determination of small color differences. Describes a method for utilizing color measuring instruments for quantifying the small color differences between plain colored glazed ceramic tiles, which are designed to be uniform and consistent color. It permits the specification of a maximum acceptable value which depends only on the closeness of match and not on the nature of the color difference.

BDS EN 490	Concrete roofing tiles and fittings for roof covering and all cladding-Product specifications.
BDS ISO 13006	Ceramic tiles - Definitions, classification, characteristics and marking. This Standard defines terms and establishes classifications characteristics and marking requirements for ceramic tiles of the best commercial quality (first quality).
BDS EN 491	Concrete roofing tiles and fittings for roof covering and wall cladding-Test methods.
BDS EN 538	Clay roofing tiles for discontinuous laying-Flexural strength test.
BDS EN 539 - 1	Clay roofing tiles for discontinuous laying. Determination of physical characteristics-Part 1: Impermeability test.
BDS EN 1024	Clay roofing tiles for discontinuous laying-Determination of geometric characteristics.
BDS EN 1304	Clay roofing tiles and fittings-Product definitions and specifications.
BDS EN 13748 - 1	Terrazzo tiles-Part 1: Terrazzo tiles for internal use.
BDS EN 13748 - 2	Terrazzo tiles-Part 2: Terrazzo tiles for external use.

2.8 Steel

2.8.1 Reinforcing Steel

Reinforcing steel shall comply with the requirements specified in Sec 2.4.6 in this Part.

2.8.2 Structural Steel

Structural steel shall conform to Bangladesh Standards BDS 878: 1978, Specification for weld able structural steels; BDS 1355: 1992, Dimensions and properties of hot rolled steel beam, column, channel and angle sections. Where Bangladesh standards are not available, the relevant standards listed below shall be applicable.

BDS 1429	Light gauge steel sections.
BDS ISO 2566-1	Steel-Conversion of elongation values-Part 1: Carbon and low alloy steels.

BDS ISO 2566-2	Steel-Conversion of elongation values-Part 2: Austenitic steels.
BDS ISO 657-1	Hot-rolled steel sections-Part 1: Equal-leg angles-Dimensions.
BDS ISO 657-2	Hot-rolled steel sections-Part 2: Unequal-leg angles-Dimensions.
BDS ISO 657-5	Hot-rolled steel sections-Part V Equal-leg angles and unequal leg angles-Tolerances for metric and inch series.
BDS ISO 657-11	Hot-rolled steel sections-Part 11: Sloping flange channel sections (Metric series)-Dimensions and sectional properties.
BDS ISO 657-15	Hot-rolled steel sections-Part 15 Sloping flange beam sections (Metric series)-Dimensions and sectional properties.
BDS ISO 657-16	Hot-rolled steel sections-Part 16: Sloping flange column sections (metric series)-Dimensions and sectional properties.
BDS ISO 657-18	Hot-rolled steel sections-Part 18: L sections for shipbuilding (metric series) 104-Dimensions, sectional properties and tolerances.
BDS ISO 657-19	Hot-rolled steel sections-Part 19: Bulb flats (metric series)-Dimensions, sectional properties and tolerances.
BDS ISO 657-21	Hot-rolled steel sections-Part 21 T-sections with equal depth and flange width-Dimensions.
BDS ISO 10474	Steel and steel products-Inspection documents.
BDS ISO 14284	Steel and iron-Sampling and preparation of samples for the determination of chemical composition.
BDS ISO 9769	Steel and iron-Review of available methods of analysis.
BDS ISO 6929	Steel products-Definition and classification.
BDS ISO 20723	Structural steels-Surface condition of hot-rolled sections-Delivery requirements.
BDS ISO 24314	Structural steels-Structural steels for building with improved seismic resistance-Technical delivery conditions.

BDS ISO 404	Steel and steel products-General technical delivery requirements.
BDS ISO 1127	Stainless steel tubes-Dimensions, tolerances and conventional masses per unit length.
BDS ISO 4200	Plain end steel tubes, welded and seamless-General tables of dimensions and masses per unit length.
BDS ISO 6761	Steel tubes-Preparation of ends of tubes and fittings for welding.
ASTM A27/A27M	Standard Specification for Steel Castings, Carbon, for General Application.
ASTM A36/A36M	Standard Specification for Carbon Structural Steel.
ASTM A48/A48M	Standard Specification for Gray Iron Castings.
ASTM A53/A53M	Standard Specification for Pipe, Steel, Black and Hot-Dipped, Zinc-Coated, Welded and Seamless.
ASTM A148/A148M	Standard Specification for Steel Castings, High Strength, for Structural Purposes.
ASTM A242/A242M	Standard Specification for High-Strength Low-Alloy Structural Steel.
ASTM A252	Standard Specification for Welded and Seamless Steel Pipe Piles.
ASTM A283/A283M	Standard Specification for Low and Intermediate Tensile Strength Carbon Steel Plates.
ASTM A307	Standard Specification for Carbon Steel Bolts and Studs, 60,000 psi Tensile Strength.
ASTM A325	Standard Specification for Structural Bolts, Steel, Heat Treated, 120/105 ksi Minimum Tensile Strength.
ASTM A325M	Standard Specification for Structural Bolts, Steel, Heat Treated 830 MPa Minimum Tensile Strength [Metric].
ASTM A336/A336M	Standard Specification for Alloy Steel Forgings for Pressure and High-Temperature Parts.

ASTM A653/A653M	Standard Specification for Steel Sheet, Zinc-Coated (Galvanized) or Zinc-Iron Alloy-Coated (Galvannealed) by the Hot-Dip Process.
ASTM A449	Standard Specification for Hex Cap Screws, Bolts and Studs, Steel, Heat Treated, 120/105/90 ksi Minimum Tensile Strength, General Use.
ASTM A490	Standard Specification for Structural Bolts, Alloy Steel, Heat Treated, 150 ksi Minimum Tensile Strength.
ASTM A500/A500M	Standard Specification for Cold-Formed Welded and Seamless Carbon Steel Structural Tubing in Rounds and Shapes.
ASTM A501	Standard Specification for Hot-Formed Welded and Seamless Carbon Steel Structural Tubing.
ASTM A514/A514M	Standard Specification for High-Yield-Strength, Quenched and Tempered Alloy Steel Plate, Suitable for Welding.
ASTM A529/A529M	Standard Specification for High-Strength Carbon-Manganese Steel of Structural Quality.
ASTM A563	Standard Specification for Carbons and Alloy Steel Nuts.
ASTM A563M	Standard Specification for Carbon and Alloy Steel Nuts [Metric].
ASTM A1011/A1011M	Standard Specification for Steel, Sheet and Strip, Hot-Rolled, Carbon, Structural, High-Strength Low-Alloy, High-Strength Low-Alloy with Improved Formability, and Ultra-High Strength.
ASTM A572/A572M	Standard Specification for High-Strength Low-Alloy Columbium-Vanadium Structural Steel.
ASTM A588/A588M	Standard Specification for High-Strength Low-Alloy Structural Steel, up to 50 ksi [345 MPa] Minimum Yield Point, with Atmospheric Corrosion Resistance.
ASTM A606/A606M	Standard Specification for Steel, Sheet and Strip, High-Strength, Low-Alloy, Hot-Rolled and Cold-Rolled, with Improved Atmospheric Corrosion Resistance.

ASTM A1008/A1008M	Standard Specification for Steel, Sheet, Cold-Rolled, Carbon, Structural, High-Strength Low-Alloy, High-Strength Low-Alloy with Improved Formability, Solution Hardened, and Bake Harden able.
ASTM A618/A618M	Standard Specification for Hot-Formed Welded and Seamless High-Strength Low-Alloy Structural Tubing.
ASTM A666	Standard Specification for Annealed or Cold-Worked Austenitic Stainless Steel Sheet, Strip, Plate, and Flat Bar.
ASTM A668/A668M	Standard Specification for Steel Forgings, Carbon and Alloy, for General Industrial Use.
ASTM A690/A690M	Standard Specification for High-Strength Low-Alloy Nickel, Copper, Phosphorus Steel H-Piles and Sheet Piling with Atmospheric Corrosion Resistance for Use in Marine Environments.
ASTM A852/A852M	Standard Specification for Quenched and Tempered Low-Alloy Structural Steel Plate with 70 ksi [485 MPa] Minimum Yield Strength to 4 in. [100 mm] Thick.

2.8.3 Steel Plate, Sheet and Strips

These shall conform to the following standards.

BDS 868 : 1978	Code of practice for galvanized corrugated sheet roof and wall coverings.
BDS 1122: 1985	Specification for hot-dip galvanized steel sheet and coil.
BDS ISO 9328-1	Steel flat products for pressure purposes-Technical delivery conditions-Part 1: general requirements.
BDS ISO 9328-2	Steel flat products for pressure purposes-Technical delivery conditions-Part 2: Non-alloy and alloy steels with specified elevated temperature properties.
BDS ISO 9328-3	Steel flat products for pressure purposes-Technical delivery conditions -Part 3: Weldable fine grain steels, normalized.
BDS ISO 9328-4	Steel flat products for pressure purposes-Technical delivery conditions-Part 4: Nickel-alloy steels with specified low temperature properties.

BDS ISO 9328-5	Steel flat products for pressure purposes-Technical delivery conditions-Part 5: Weldable fine grain steels, thermo mechanically rolled.
BDS ISO 9328-6	Steel flat products for pressure purposes-Technical delivery conditions-Part 6: Weldable fine grain steels, quenched and tempered.
BDS ISO 9328-7	Steel flat products for pressure purposes-Technical delivery conditions-Part 7: Stainless steels.
BDS ISO 4995	Hot-rolled steel sheet of structural quality.
BDS ISO 7452	Hot-rolled structural steel plates-Tolerances on dimensions and shape.
BDS ISO 7778	Steel plate with specified through-Thickness characteristics.
BDS ISO 7788	Steel-Surface finish of hot-rolled plates and wide flats-Delivery requirements.
BDS ISO 9034	Hot-rolled structural steel wide flats-Tolerances on dimensions and shape.
BDS ISO 9364	Continuous hot-dip aluminum/zinc coated steel sheet of commercial, drawing and structural qualities.
BDS ISO 16160	Continuously hot-rolled steel sheet products-Dimensional and shape tolerances.
BDS ISO 16162	Continuously cold-rolled steel sheet products-Dimensional and shape tolerances.
BDS ISO 16163	Continuously hot-dipped coated steel sheet products-Dimensional and shape tolerances.
IS 412	Specification for expanded metal steel sheets for general purposes.
IS 1079	Specification for hot rolled carbon steel sheet and strip.
IS 4030	Specification for cold-rolled carbon steel strip for general engineering purposes.
IS 7226	Specification for cold-rolled medium, high carbon and low-alloy steel strip for general engineering purposes.

IS 3502	Specification for steel chequered plates.
ASTM A109/A109M	Standard Specification for Steel, Strip, Carbon (0.25 Maximum Percent), Cold-Rolled.
ASTM A123/A123M	Standard Specification for Zinc (Hot-Dip Galvanized) Coatings on Iron and Steel Products.
ASTM A167	Standard Specification for Stainless and Heat-Resisting Chromium-Nickel Steel Plate, Sheet, and Strip.
ASTM A176	Standard Specification for Stainless and Heat-Resisting Chromium Steel Plate, Sheet, and Strip.
ASTM A240/A240M	Standard Specification for Chromium and Chromium-Nickel Stainless Steel Plate, Sheet, and Strip for Pressure Vessels and for General Applications.
ASTM A263	Standard Specification for Stainless Chromium Steel-Clad Plate.
ASTM A264	Specification for Stainless Chromium-Nickel Steel-Clad Plate.
ASTM A285/A285M	Standard Specification for Pressure Vessel Plates, Carbon Steel, Low- and Intermediate-Tensile Strength.
ASTM A328/A328M	Standard Specification for Steel Sheet Piling.
ASTM A1008/A1008M	Standard Specification for Steel, Sheet, Cold-Rolled, Carbon, Structural, High-Strength Low-Alloy, High-Strength Low-Alloy with Improved Formability, Solution Hardened, and Bake Harden able.
ASTM A414/A414M	Standard Specification for Steel, Sheet, Carbon, and High-Strength, Low-Alloy for Pressure Vessels.
ASTM A424/A424M	Standard Specification for Steel, Sheet, for Porcelain Enameling.
ASTM A929/A929M	Standard Specification for Steel Sheet, Metallic-Coated by the Hot-Dip Process for Corrugated Steel Pipe.
ASTM A463/A463M	Standard Specification for Steel Sheet, Aluminum-Coated, by the Hot-Dip Process.

ASTM A480/A480M	Standard Specification for General Requirements for Flat-Rolled Stainless and Heat-Resisting Steel Plate, Sheet, and Strip.
ASTM A505	Standard Specification for Steel, Sheet and Strip, Alloy, Hot-Rolled and Cold-Rolled, General Requirements for.
ASTM A506	Standard Specification for Alloy and Structural Alloy Steel, Sheet and Strip, Hot-Rolled and Cold-Rolled.
ASTM A507	Standard Specification for Drawing Alloy Steel, Sheet and Strip, Hot-Rolled and Cold-Rolled.
ASTM A568/A568M	Standard Specification for Steel, Sheet, Carbon, Structural, and High-Strength, Low-Alloy, Hot-Rolled and Cold-Rolled, General Requirements for.
ASTM A577/A577M	Standard Specification for Ultrasonic Angle-Beam Examination of Steel Plates.
ASTM A578/A578M	Standard Specification for Straight-Beam Ultrasonic Examination of Rolled Steel Plates for Special Applications.
ASTM A879/A879M	Standard Specification for Steel Sheet, Zinc Coated by the Electrolytic Process for Applications Requiring Designation of the Coating Mass on Each Surface.
ASTM A599/A599M	Standard Specification for Tin Mill Products, Electrolytic Tin-Coated, Cold-Rolled Sheet.
ASTM A606/A606M	Standard Specification for Steel, Sheet and Strip, High-Strength, Low-Alloy, Hot-Rolled and Cold-Rolled, with Improved Atmospheric Corrosion Resistance.
ASTM A635/A635M	Standard Specification for Steel, Sheet and Strip, Heavy-Thickness Coils, Hot-Rolled, Alloy, Carbon, Structural, High-Strength Low-Alloy, and High-Strength Low-Alloy with Improved Formability, General Requirements for.
ASTM A653/A653M	Standard Specification for Steel Sheet, Zinc-Coated (Galvanized) or Zinc-Iron Alloy-Coated (Galvannealed) by the Hot-Dip Process.
ASTM A666	Standard Specification for Annealed or Cold-Worked Austenitic Stainless Steel Sheet, Strip, Plate, and Flat Bar.

ASTM A690/A690M	Standard Specification for High-Strength Low-Alloy Nickel, Copper, Phosphorus Steel H-Piles and Sheet Piling with Atmospheric Corrosion Resistance for Use in Marine Environments.
ASTM A775/A775M	Standard Specification for Epoxy-Coated Steel Reinforcing Bars.
ASTM A792/A792M	Standard Specification for Steel Sheet, 55 % Aluminum-Zinc Alloy-Coated by the Hot-Dip Process.
ASTM A857/A857M	Standard Specification for Steel Sheet Piling, Cold Formed, Light Gage.
ASTM A875/A875M	Standard Specification for Steel Sheet, Zinc-5% Aluminum Alloy-Coated by the Hot-Dip Process.

2.8.4 Steel Pipe, Tube and Fittings

These items shall conform to the following Standards:

BDS ISO 49	Malleable cast iron fittings threaded to ISO 7-1.
BDS ISO 3419	Non-alloy and alloy steel butt-welding fittings.
BDS ISO 3545-3	Steel tubes and fittings-Symbols for use in specifications-Part 3: Tubular fittings with circular cross-section.
BDS ISO 4144	Pipe work-Stainless steel fittings threaded in accordance with ISO 7-1.
BDS ISO 4145	Non-alloy steel fittings threaded to ISO 7-1.
BDS ISO 5251	Stainless steel butt-welding fittings.
ASTM A53/A53M	Standard Specification for Pipe, Steel, Black and Hot-Dipped, Zinc-Coated, Welded and Seamless.
ASTM A105/A105M	Standard Specification for Carbon Steel Forgings for Piping Applications.
ASTM A106/A106M	Standard Specification for Seamless Carbon Steel Pipe for High-Temperature Service.
ASTM A134	Standard Specification for Pipe, Steel, Electric-Fusion (Arc)-Welded (Sizes NPS 16 and Over).

ASTM A139/A139M	Standard Specification for Electric-Fusion (Arc)-Welded Steel Pipe (NPS 4 and Over).
ASTM A181/A181M	Standard Specification for Carbon Steel Forgings, for General-Purpose Piping.
ASTM A182/A182M	Standard Specification for Forged or Rolled Alloy and Stainless Steel Pipe Flanges, Forged Fittings, and Valves and Parts for High-Temperature Service.
ASTM A234/A234M	Standard Specification for Piping Fittings of Wrought Carbon Steel and Alloy Steel for Moderate and High Temperature Service.
ASTM A252	Standard Specification for Welded and Seamless Steel Pipe Piles.
ASTM A254	Standard Specification for Copper-Brazed Steel Tubing.
ASTM A268/A268M	Standard Specification for Seamless and Welded Ferritic and Martensitic Stainless Steel Tubing for General Service.
ASTM A269	Standard Specification for Seamless and Welded Austenitic Stainless Steel Tubing for General Service.
ASTM A270	Standard Specification for Seamless and Welded Austenitic Stainless Steel Sanitary Tubing.
ASTM A312/A312M	Standard Specification for Seamless, Welded, and Heavily Cold Worked Austenitic Stainless Steel Pipes.
ASTM A333/A333M	Standard Specification for Seamless and Welded Steel Pipe for Low-Temperature Service.
ASTM A334/A334M	Standard Specification for Seamless and Welded Carbon and Alloy-Steel Tubes for Low-Temperature Service.
ASTM A403/A403M	Standard Specification for Wrought Austenitic Stainless Steel Piping Fittings.
ASTM A420/A420M	Standard Specification for Piping Fittings of Wrought Carbon Steel and Alloy Steel for Low-Temperature Service.
ASTM A423/A423M	Standard Specification for Seamless and Electric-Welded Low-Alloy Steel Tubes.

ASTM A450/A450M	Standard Specification for General Requirements for Carbon and Low Alloy Steel Tubes.
ASTM A500/A500M	Standard Specification for Cold-Formed Welded and Seamless Carbon Steel Structural Tubing in Rounds and Shapes.
ASTM A50	Standard Specification for Hot-Formed Welded and Seamless Carbon Steel Structural Tubing.
ASTM A522/A522M	Standard Specification for Forged or Rolled 8 and 9% Nickel Alloy Steel Flanges, Fittings, Valves, and Parts for Low-Temperature Service.
ASTM A524	Standard Specification for Seamless Carbon Steel Pipe for Atmospheric and Lower Temperatures.
ASTM A530/A530M	Standard Specification for General Requirements for Specialized Carbon and Alloy Steel Pipe.
ASTM A589/A589M	Standard Specification for Seamless and Welded Carbon Steel Water-Well Pipe.
ASTM A618/A618M	Standard Specification for Hot-Formed Welded and Seamless High-Strength Low-Alloy Structural Tubing.
ASTM A632	Standard Specification for Seamless and Welded Austenitic Stainless Steel Tubing (Small-Diameter) for General Service.
ASTM A707/A707M	Standard Specification for Forged Carbon and Alloy Steel Flanges for Low-Temperature Service.
ASTM A733	Standard Specification for Welded and Seamless Carbon Steel and Austenitic Stainless Steel Pipe Nipples.
ASTM A778	Standard Specification for Welded, Un-annealed Austenitic Stainless Steel Tubular Products.
ASTM A807/A807M	Standard Practice for Installing Corrugated Steel Structural Plate Pipe for Sewers and Other Applications.
ASTM A865/A865M	Standard Specification for Threaded Couplings, Steel, Black or Zinc-Coated (Galvanized) Welded or Seamless, for Use in Steel Pipe Joints.

2.8.5 Steel Bars, Wire and Wire Rods

These shall conform to the following Standards.

BDS ISO 1035-1	Hot-rolled steel bars-Part 1: Dimensions of round bars.
BDS ISO 1035-2	Hot-rolled steel bars-Part 2: Dimensions of square bars.
BDS ISO 1035-3	Hot-rolled steel bars-Part 3: Dimensions of flat bars.
BDS ISO 1035-4	Hot-rolled steel bars-Part 4: Tolerances.
BDS ISO 4951-1	High yield strength steel bars and sections-Part 1: General delivery requirements.
BDS ISO 4951-2	High yield strength steel bars and sections-Part 2: Delivery conditions for normalized, normalized rolled and as-rolled steels.
BDS ISO 4951-3	High yield strength steel bars and sections-Part 3: Delivery conditions for thermo mechanically-rolled steels.
ASTM A29/A29M	Standard Specification for Steel Bars, Carbon and Alloy, Hot-Wrought, General Requirements for.
ASTM A49	Standard Specification for Heat-Treated Carbon Steel Joint Bars, Micro alloyed Joint Bars, and Forged Carbon Steel Compromise Joint Bars.
ASTM A108	Standard Specification for Steel Bar, Carbon and Alloy, Cold-Finished.
ASTM A116	Standard Specification for Metallic-Coated, Steel Woven Wire Fence Fabric.
ASTM A185/A185M	Standard Specification for Steel Welded Wire Reinforcement, Plain, for Concrete.
ASTM A227/A227M	Standard Specification for Steel Wire, Cold-Drawn for Mechanical Springs.
ASTM A228/A228M	Standard Specification for Steel Wire, Music Spring Quality.
ASTM A229/A229M	Standard Specification for Steel Wire, Oil-Tempered for Mechanical Springs.
ASTM A276	Standard Specification for Stainless Steel Bars and Shapes.

ASTM A311/A311M	Standard Specification for Cold-Drawn, Stress-Relieved Carbon Steel Bars Subject to Mechanical Property Requirements.
ASTM A322	Standard Specification for Steel Bars, Alloy, Standard Grades.
ASTM A108	Standard Specification for Steel Bar, Carbon and Alloy, Cold-Finished.
ASTM A368	Standard Specification for Stainless Steel Wire Strand.
ASTM A434	Standard Specification for Steel Bars, Alloy, Hot-Wrought or Cold-Finished, Quenched and Tempered.
ASTM A475	Standard Specification for Zinc-Coated Steel Wire Strand.
ASTM A478	Standard Specification for Chromium-Nickel Stainless Steel Weaving and Knitting Wire.
ASTM A479/A479M	Standard Specification for Stainless Steel Bars and Shapes for Use in Boilers and Other Pressure Vessels.
ASTM A492	Standard Specification for Stainless Steel Rope Wire.
ASTM A499	Standard Specification for Steel Bars and Shapes, Carbon Rolled from “T” Rails.
ASTM A510	Standard Specification for General Requirements for Wire Rods and Coarse Round Wire, Carbon Steel.
ASTM A575	Standard Specification for Steel Bars, Carbon, Merchant Quality, M-Grades.
ASTM A576	Standard Specification for Steel Bars, Carbon, Hot-Wrought, Special Quality.
ASTM A580/A580M	Standard Specification for Stainless Steel Wire.
ASTM A586	Standard Specification for Zinc-Coated Parallel and Helical Steel Wire Structural Strand.
ASTM A603	Standard Specification for Zinc-Coated Steel Structural Wire Rope.
ASTM A627	Standard Test Methods for Tool-Resisting Steel Bars, Flats, and Shapes for Detention and Correctional Facilities.

ASTM A663/A663M	Standard Specification for Steel Bars, Carbon, Merchant Quality, Mechanical Properties.
ASTM A666	Standard Specification for Annealed or Cold-Worked Austenitic Stainless Steel Sheet, Strip, Plate, and Flat Bar.
ASTM A706/A706M	Standard Specification for Low-Alloy Steel Deformed and Plain Bars for Concrete Reinforcement.
ASTM A764	Standard Specification for Metallic Coated Carbon Steel Wire, Coated at Size and Drawn to Size for Mechanical Springs.
ASTM C933	Standard Specification for Welded Wire Lath.

2.8.6 Steel Fasteners

Steel fasteners shall conform to the following Standards:

BDS 1373	Slotted countersunk flat head tapping screws.
BDS 1374	Slotted raised counter.
BDS 1375	Fasteners hexagon products widths across flats.
BDS 1405	Bolts, screws, nuts and accessories terminology and nomenclature.
BDS 1406	Hexagon nuts style 2 products grades A and B.
BDS 1407	Hexagon nuts style 3 products grades A and B.
BDS 1408	General purpose screw threads general plan.
BDS 1409	General purpose screw threads selected sizes for screws, bolts and nuts.
BDS 1410	Thread run-outs for fasteners thread of BDS 1408: 1995 and BDS 1409: 1993.
BDS 1411	Tapping screws thread.
BDS 1412	Thread undercuts of external metric thread fasteners.
BDS 1413	Head configuration and gauging of countersunk head screws.
BDS 1428	Fasteners-bolts, screws, studs and nuts-symbols and designations of dimensions.

ASTM A31	Standard Specification for Steel Rivets and Bars for Rivets, Pressure Vessels.
ASTM A183	Standard Specification for Carbon Steel Track Bolts and Nuts.
ASTM A193/A193M	Standard Specification for Alloy-Steel and Stainless Steel Bolting Materials for High Temperature or High Pressure Service and Other Special Purpose Applications.
ASTM A194/A194M	Standard Specification for Carbon and Alloy Steel Nuts for Bolts for High Pressure or High Temperature Service, or Both.
ASTM A307	Standard Specification for Carbon Steel Bolts and Studs, 60000 psi Tensile Strength.
ASTM A320/A320M	Standard Specification for Alloy-Steel and Stainless Steel Bolting Materials for Low-Temperature Service.
ASTM A325	Standard Specification for Structural Bolts, Steel, Heat Treated, 120/105 ksi Minimum Tensile Strength.
ASTM A354	Standard Specification for Quenched and Tempered Alloy Steel Bolts, Studs, and Other Externally Threaded Fasteners.
ASTM A437/A437M	Standard Specification for Stainless and Alloy-Steel Turbine-Type Bolting Specially Heat Treated for High-Temperature Service.
ASTM A449	Standard Specification for Hex Cap Screws, Bolts and Studs, Steel, Heat Treated, 120/105/90 ksi Minimum Tensile Strength, General Use.
ASTM A489	Standard Specification for Carbon Steel Lifting Eyes.
ASTM A490	Standard Specification for Structural Bolts, Alloy Steel, Heat Treated, 150 ksi Minimum Tensile Strength.
ASTM A502	Standard Specification for Rivets, Steel, Structural.
ASTM A540/A540M	Standard Specification for Alloy-Steel Bolting for Special Applications.
ASTM A563	Standard Specification for Carbons and Alloy Steel Nuts.

ASTM A574	Standard Specification for Alloy Steel Socket-Head Cap Screws.
ASTM C514	Standard Specification for Nails for the Application of Gypsum Board.
ASTM C954	Standard Specification for Steel Drill Screws for the Application of Gypsum Panel Products or Metal Plaster Bases to Steel Studs from 0.033 in. (0.84 mm) to 0.112 in. (2.84 mm) in Thickness.
ASTM C955	Standard Specification for Load-Bearing (Transverse and Axial) Steel Studs, Runners (Tracks), and Bracing or Bridging for Screw Application of Gypsum Panel Products and Metal Plaster Bases.
ASTM C1002	Standard Specification for Steel Self-Piercing Tapping Screws for the Application of Gypsum Panel Products or Metal Plaster Bases to Wood Studs or Steel Studs.
ASTM F436	Standard Specification for Hardened Steel Washers.
ASTM F593	Standard Specification for Stainless Steel Bolts, Hex Cap Screws, and Studs.
ASTM F594	Standard Specification for Stainless Steel Nuts.
ASTM F844	Standard Specification for Washers, Steel, Plain (Flat), Unhardened for General Use.
ASTM F959	Standard Specification for Compressible-Washer-Type Direct Tension Indicators for Use with Structural Fasteners.

2.8.7 Welding Electrodes and Wires

Welding electrodes and wires shall conform to the following Standards:

BDS 239	Specification for soft solder.
BDS 1442-1	Filler rods and wire for gas shielded arc-welding-ferric steel.
BDS 1442-2	Filler rods and wire for gas shielded arc-welding-austenitic stainless steel.

BDS 1442-3	Filler rods and wires for gas shielded arc welding-copper and copper alloy.
BDS 1442-4	Filler rods and wires for gas shielded arc welding-aluminum and aluminum alloy and magnesium alloys.
BDS 1442-5	Filler rods and wires for gas shielded arc welding-nickel and nickel alloys.
IS 814	Specification for covered electrodes for manual metal arc welding of carbon and carbon manganese steel.
IS 815	Classification and coding of covered electrodes for metal arc welding of structural steels.
IS 1278	Specification for filler rods and wires for gas welding.
IS 1395	Specification for low and medium alloy steel covered electrodes for manual metal arc welding.
IS 3613	Acceptance tests for wire flux combinations for submerged-arc welding of structural steel.
IS 4972	Specification for resistance spot-welding electrodes.
IS 6419	Specification for welding rods and bare electrodes for gas shielded arc welding of structural steel.
IS 6560	Specification for molybdenum and chromium-molybdenum low alloy steel welding rods and bare electrodes for gas shielded arc welding.
IS 7280	Specification for base wire electrodes for submerged-arc welding of structural steels.
IS 8363	Specification for bare wire electrodes for electro slag welding of steels.
ISO 9453	Soft solder alloys-chemical compositions and forms.
ISO 9454	Soft soldering fluxes-classification and requirements. Part 1: Classification, labeling and packaging.
ISO 9455-1	Soft soldering fluxes- test methods. Part 1: Determination of non-volatile matter, gravimetric method.

ISO 9455-8	Soft soldering fluxes-test methods. Part 8: Determination of zinc content.
ISO 9455-11	Soft soldering fluxes-test methods. Part 11: Solubility of flux residues.
ISO 9455-14	Soft soldering fluxes-test methods. Part 14: Assessment of tackiness of flux residues.

2.9 Timber & Wood Products

2.9.1 Timber Types and Properties

Timber types for the structural purpose with their engineering characteristics are contained in Table 6.11.1 Part 6 of this Code. Details of the uses of timber in structures or elements of structures including terminology, material requirements, and moisture content preferred cut sizes of sawn timbers, grading, permissible defects, suitability in respect of durability and treatability, design criteria, and details of joints are also given in Chapter 11 Part 6. Timber and timber constructions shall satisfy the requirements of that Chapter and conform to the following Standards:

BDS 142	Specification for wood doors.
BDS 173	Specification for wood windows.
BDS 230	Glossary of terms applicable to timber, plywood and joinery.
BDS 803	Trade names and abbreviated symbols for timber species.
BDS 819	Code of practice for preservation of timber.
BDS 820	Recommendation for maximum permissible moisture content of timber used for different purposes in Bangladesh.
BDS 857	Specification for grading rules for logs and sawn timbers.
BDS 1090	Methods of test for plywood.
BDS 1256	Classification of commercial timber.
BDS 1311	Key for identification of commercial timber.

2.9.2 Plywood

A wood structural panel comprised of plies of wood veneer arranged in cross-aligned layers. The plies are bonded with waterproof adhesive that cures on application of heat and pressure.

Plywood shall conform to the following Standards:

- BDS 799 Specification for plywood for general purposes.
- BDS 1158 Specification for veneered decorative plywood.

For sampling and testing of plywood, the following Standards are applicable:

- BDS 1087 Specification for method of sampling of plywood.
- BDS 1090 Methods of test of plywood.
- IS 4990 Specification for plywood for concrete shattering work.
- IS 5509 Specification for fire retardant plywood.
- IS 5539 Specification for Preservative Treated Plywood.

2.9.3 Particle Boards and Fibre Boards

A panel primarily composed of cellulosic materials (usually wood), generally in the form of discrete pieces or particles, as distinguished from fibers. The cellulosic material is combined with synthetic resin or other suitable bonding system by a process in which the inter-particle bond is created by the bonding system under heat and pressure.

Fiber boards are fibrous, homogeneous panel made from lingo-cellulosic fibers (usually wood or cane) and having a density of less than 497 kg per cubic meter but more than 160 kg per cubic meter.

These materials shall conform to the following standards:

- BDS 619 Specification for particle board (medium density).
- BDS 620 Specification for hardboard.
- BDS EN 316 Wood fiberboards-Definition, classification and symbols.
- ISO 820 Particle boards-Definition and classification.

ISO 821	Particle boards-Determination of dimensions of test pieces.
ISO 822	Particle boards-Determination of density.
ISO 823	Particle boards-Determination of moisture content.
ISO 766	Fibre building boards-Determination of dimensions of test pieces.
ISO 767	Fibre building boards-Determination of moisture content.
ISO 768	Fibre building boards-Determination of bending strength.
ISO 769	Fibre building boards-Hard and medium boards-determination of.

Water Absorption and of Swelling in Thickness after Immersion in Water;

ISO 818	Fibre building boards-Definition-Classification.
ISO 819	Fibre building boards-Determination of density.
ISO 2695	Fibre building boards-Hard and medium boards for general.

Purposes-Quality Specifications-Appearance, Shape and Dimensional Tolerances;

ISO 2696	Fibre building boards-Hard and medium boards-Quality.
----------	---

Specifications- Water Absorption and Swelling in Thickness;

ISO 3340	Fibre building boards-Determination of sand content.
ISO 3346	Fibre building boards-Determination of surface finish (roughness).
ISO 3729	Fibre building boards-Determination of surface stability.
ISO/TR 7469	Dimensional stability of hardboards.

Wood based Laminates

Laminated boards having a core of strips, each not exceeding 7 mm in thickness, glued together face to face to form a slab which in turn is glued between two or more veneers, with the direction of the grain of the core strips running at right angles to that of the adjacent outer veneers.

Wood based laminates shall conform to the following Standards:

- | | |
|------------------------------|--|
| IS 3513 | Specification for resin treated compressed wood laminates (compregs).
Part 3 For general purposes. |
| IS 3513 | Specification for resin treated compressed wood laminates (compregs).
Part 4 Sampling and Tests. |
| IS 9307
(Parts I to VIII) | Methods of tests for wood-based structural sandwich construction.
Part I Flexure test.
Part II Edgewise compression test.
Part III Flatwise compression test.
Part IV Shear test.
Part V Flatwise tension test.
Part VI Flexure creep test.
Part VII Cantilever vibration test.
Part VIII Weathering test. |

2.9.4 Adhesives and Glues

Adhesives and glues are used to join two or more parts so as to form a single unit. Adhesives shall conform to the following Standards:

- | | |
|---------|--|
| IS 848 | Specification for synthetic resin adhesives for plywood (phenolic and aminoplastic). |
| IS 849 | Specification for cold setting case in glue for wood. |
| IS 851 | Specification for synthetic resin adhesives for construction work (nonstructural) in wood. |
| IS 852 | Specification for animal glue for general wood-working purposes. |
| IS 4835 | Specification for polyvinyl acetate dispersion-based adhesives for wood. |
| IS 9188 | Specification for adhesive for structural laminated wood products for use under exterior exposure condition. |

2.10 Doors, Windows and Ventilators

2.10.1 Wooden Doors, Windows and Ventilators

These shall conform to the following Standards:

BDS 142	Specification for wood door.
BDS 173	Specification for wood windows.
BDS 820	Recommendation for maximum permissible moisture content of timber used for different purposes in Bangladesh.
BDS 1504	Timber door window and ventilator frames
IS 1003	Specification for timber panelled and glazed shutters. Part 1- 2003 Door shutters. Part 2- 1994 Window and ventilator shutters.
IS 1826	Specification for venetian blinds for windows.
IS 2191	Specification for wooden flush door shutters (cellular and hollow core type). Part 1 Plywood face panels. Part 2 Particle board face panels and hardboard face panels.
IS 2202	Specification for wooden flush door shutters (solid core type). Part 1 Plywood face panels. Part 2 Particle board face panels and hardboard face panels.
IS 4020	Method of tests for door shutters. (Part 1): 1998 General. (Part 2): 1998 Measurement of dimensions and squareness. (Part 3): 1998 Measurement of general flatness. (Part 4): 1998 Local planeness test. (Part 5): 1998 Impact indentation test. (Part 6): 1998 Flexure test.

	(Part 7): 1998	Edge loading test.
	(Part 8): 1998	Shock resistance test.
	(Part 9): 1998	Buckling resistance test.
	(Part 10):1998	Slamming test.
	(Part 11):1998	Misuse test.
	(Part 12):1998	Varying humidity test.
	(Part 13):1998	End immersion test.
	(Part 14):1998	Knife test.
	(Part 15):1998	Glue adhesion test.
	(Part 16):1998	Screw withdrawal resistance test.
IS 4021		Specification for timber door, window and ventilator frames.
IS 4962		Specification for wooden side sliding doors.
IS 6198		Specification for ledged, braced and battened timber shutters.

2.10.2 Metal Doors, Windows Frames and Ventilators

These shall conform to the following Standards:

BDS 1270	Specification for strong room door
BDS 1273	Specification for vault doors.
IS 1038	Specification for steel doors, windows and ventilators.
IS 1361	Specification for steel windows for industrial buildings.
IS 1948	Specification for aluminum doors, windows and ventilators.
IS 1949	Specification for aluminum windows for industrial buildings.
IS 4351	Specification for steel door frames.
IS 6248	Specification for metal rolling shutters and rolling grills.
IS 7452	Specification for hot rolled steel sections for doors, windows and ventilators.
IS 10451	Specification for steel sliding shutters (top hung type).
IS 10521	Specification for collapsible gates.

2.10.3 Plastic Doors and Windows

These shall conform to the following Standards:

BDS EN 477	Unplasticized polyvinylchloride (PVC-U) profiles for the fabrication of windows and doors-Determination of the resistance to impact of main profiles by falling mass.
BDS EN 478	Unplasticized polyvinylchloride (PVC-U) profiles for the fabrication of windows and doors-Determination of appearance after exposure at 150°C.
BDS EN 479	Unplasticized polyvinylchloride (PVC-U) profiles for the fabrication of windows and doors-Determination of heat reversion.
BDS EN 513	Unplasticized polyvinylchloride (PVC-U) profiles for the fabrication of windows and doors-Determination of the resistance to artificial weathering.
BDS EN 514	Unplasticized polyvinylchloride (PVC-U) profiles for the fabrication of windows and doors-Determination of the strength of welded corners and T-joints.
BDS EN 12608	Unplasticized polyvinylchloride (PVC-U) profiles for the fabrication of windows and doors-Classification, requirements and test methods.
BDS ISO 1163-1	Plastics-Unplasticized polyvinylchloride (PVC-U) molding and extrusion materials-Part 1: Designation system and basis for specifications.
BDS ISO 1163-2	Plastics-Unplasticized polyvinylchloride (PVC-U) molding and extrusion materials-Part 2: Preparation of test specimens and determination of properties.
IS 14856	Specification for glass fibre reinforced (GRP) panel type door shutters for internal use.
IS 15380	Specification for molded raised high density fibre (HDF) panel doors.

2.11 Aluminium and Aluminium Alloys

Aluminum used for structural purposes in buildings and structures shall comply with AA ASM 35 and AA ADM 1.

Aluminium and Aluminium Alloys shall also conform to the following Standards:

BDS EN 755-9	Aluminum and aluminum alloys-Extruded rod/bar, tube and profiles-Part 9: Profiles, tolerances on dimensions and form.
BDS EN 755-2	Aluminum and aluminum alloys-Extruded rod/bar, tube and profiles-Part 2: Mechanical properties.
BDS EN 755-1	Aluminum and aluminum alloys-Extruded rod/bar, tube and profiles-Part 1: Technical conditions for inspection and delivery.
BDS EN 755-3	Aluminum and aluminum alloys-Extruded rod/bar, tube and profiles-Part 3: Round bars, tolerances on dimensions and form.
BDS EN 755-4	Aluminum and aluminum alloys-Extruded rod/bar, tube and profiles-Part 4: Square bars, tolerances on dimensions and form.
BDS EN 755-5	Aluminum and aluminum alloys-Extruded rod/bar, tube and profiles-Part 5: Rectangular bars, tolerances on dimensions and form.
BDS EN 755-6	Aluminum and aluminum alloys-Extruded rod/bar, tube and profiles-Part 6: Hexagonal bars, tolerances on dimensions and form.
BDS EN 755-7	Aluminum and aluminum alloys-Extruded rod/bar, tube and profiles-Part 7: Seamless tubes, tolerances on dimensions and form.
BDS EN 755-8	Aluminum and aluminum alloys-Extruded rod/bar, tube and profiles-Part 8: Porthole tubes, tolerances on dimensions and form.
BDS EN 12020-1	Aluminum and aluminum alloys- Extruded precision profiles in alloys EN AW-6060 and EN AW-6063- Part 1: Technical conditions for inspection and delivery.
BDS EN 12020-2	Aluminum and aluminum alloys-Extruded precision profiles in alloys EN AW-6060 and EN AW-6063-Part 2: Tolerances on dimensions and form.

BDS EN 515	Aluminum and aluminum alloys-Wrought products-Temper designations.
ASTM B26/B26M	Standard Specification for Aluminum-Alloy Sand Castings.
ASTM B85/B85M	Standard Specification for Aluminum-Alloy Die Castings.
ASTM B108/B108M	Standard Specification for Aluminum-Alloy Permanent Mold Castings.
ASTM B209	Standard Specification for Aluminum and Aluminum-Alloy Sheet and Plate.
ASTM B210	Standard Specification for Aluminum and Aluminum-Alloy Drawn Seamless Tubes.
ASTM B211	Standard Specification for Aluminum and Aluminum-Alloy Bar, Rod, and Wire.
ASTM B221	Standard Specification for Aluminum and Aluminum-Alloy Extruded Bars, Rods, Wire, Profiles, and Tubes.
ASTM B241/B241M	Standard Specification for Aluminum and Aluminum-Alloy Seamless Pipe and Seamless Extruded Tube.
ASTM B308/B308M	Standard Specification for Aluminum-Alloy 6061-T6 Standard Structural Profiles.
ASTM B313/B313M	Standard Specification for Aluminum and Aluminum-Alloy Round Welded Tubes.
ASTM B316/B316M	Standard Specification for Aluminum and Aluminum-Alloy Rivet and Cold-Heading Wire and Rods.
ASTM B429/B429M	Standard Specification for Aluminum-Alloy Extruded Structural Pipe and Tube.
ASTM B483/B483M	Standard Specification for Aluminum and Aluminum-Alloy Drawn Tube and Pipe for General Purpose Applications.
ASTM B547/B547M	Standard Specification for Aluminum and Aluminum-Alloy Formed and Arc-Welded Round Tube.
ASTM B632/B632M	Standard Specification for Aluminum-Alloy Rolled Tread Plate.
ASTM B745/B745M	Standard Specification for Corrugated Aluminum Pipe for Sewers and Drains.
ASTM E34	Standard Test Methods for Chemical Analysis of Aluminum and Aluminum-Base Alloys.

2.12 Builders Hardware

The applicable Standards are listed below:

- | | |
|---------|---|
| BDS 113 | Specification for latches and locks for doors in buildings. |
| IS 204 | Specification for tower bolts.
Part 1 Ferrous metals.
Part 2 Nonferrous metals. |
| IS 205 | Specification for nonferrous metal butt hinges. |
| IS 206 | Specification for tee and strap hinges. |
| IS 208 | Specification for door handles. |
| IS 281 | Specification for mild steel sliding door bolts for use with padlock. |
| IS 362 | Specification for parliament hinges. |
| IS 363 | Specification for hasps and staples. |
| IS 364 | Specification for fanlight catch. |
| IS 452 | Specification for door springs, rat-tail type. |
| IS 453 | Specification for double acting spring hinges. |
| IS 729 | Specification for drawer locks, cupboard locks and box locks. |
| IS 1019 | Specification for rim latches. |
| IS 1341 | Specification for steel butt hinges. |
| IS 1823 | Specification for floor door stoppers. |
| IS 1837 | Specification for fanlight pivots. |
| IS 2209 | Specification for mortise locks (vertical type). |
| IS 2681 | Specification for nonferrous metal sliding door bolts for use with padlocks. |
| IS 3564 | Specification for door closers (hydraulically regulated). |
| IS 3818 | Specification for continuous (piano) hinges. |
| IS 3828 | Specification for ventilator chains. |
| IS 3843 | Specification for steel back-flap hinges. |

IS 3847	Specification for mortise night latches.
IS 4621	Specification for indicating bolts for use in public baths and lavatories.
IS 4948	Specification for welded steel wire fabric for general use.
IS 4992	Specification for door handles for mortise locks (vertical type).
IS 5187	Specification for flush bolts.
IS 5899	Specification for bathroom latches.
IS 5930	Specification for mortise latch (vertical type).
IS 6315	Specification for floor springs (hydraulically regulated) for heavy doors.
IS 6318	Specification for plastic window stays and fasteners.
IS 6343	Specification for door closers (pneumatically regulated) for light doors weighing up to 40 kg.
IS 6602	Specification for ventilator poles.
IS 6607	Specification for rebated mortise locks (vertical type).
IS 7196	Specification for hold fast.
IS 7197	Specification for double action floor springs (without oil check) for heavy doors.
IS 7534	Specification for sliding locking bolts for use with padlocks.
IS 7540	Specification for mortise dead locks.
IS 8756	Specification for ball catches for use in wooden almirah.
IS 8760	Specification for mortise sliding door locks, with lever mechanism.
IS 9106	Specification for rising butt hinges.
IS 9131	Specification for rim locks.
IS 9460	Specification flush drop handle for drawer.
IS 9899	Specification for hat, coat and wardrobe hooks.
IS 10019	Specification for steel window stays and fasteners.

- IS 10090 Specification for numerical.
- IS 10342 Specification for curtain rail system.
- IS 12817 Specification for stainless steel butt hinges.
- IS 12867 Specification for PVC hand rails covers.
- IS 14912 Specification for door closers concealed type (hydraulically regulated)

2.13 Roof Coverings

2.13.1 Scope

The provisions of this Section shall govern the materials used for roof coverings.

2.13.2 Compatibility of Materials

All roofs and roof coverings shall be of materials that are compatible with each other and with the building or structure to which the materials are applied.

2.13.3 Material Specifications and Physical Characteristics

All materials to be used in the construction of roofs and roof coverings shall conform to the applicable standards listed in this Section. In the absence of applicable standards or when materials are of questionable suitability, testing by an approved testing agency may be required by the building official to determine the character, quality and limitations of use of the materials.

2.13.4 Weather Protection

All roofs shall be covered with approved roof coverings properly secured to the building or structure to resist wind and rain. Roof coverings shall be designed, installed and maintained in accordance with approved manufacturer's recommendations such that the roof covering shall serve to protect the building or structure.

2.13.5 Wind Resistance

All roofs and roof coverings shall be secured in place to the building or structure to withstand the wind loads.

2.13.6 Structural and Construction Loads

The structural roof components shall be capable of supporting the roof covering system and the material and equipment loads that will be encountered during installation of the roof covering system.

2.13.7 Impact Resistance

Roof coverings shall resist impact damage based on the results of tests conducted in accordance with ASTM D4272 or ASTM D3746.

2.13.8 Metal-Sheet Roof Coverings

Metal-sheet roof coverings installed over structural framing and decking shall comply with BDS 868, Galvanized corrugated sheet roof and wall coverings; BDS 1122, Hot-dip galvanized steel sheet and coil; ASTM A755/A755M or ASTM B101. Metal-sheet roof coverings shall be installed in accordance with approved manufacturer's installation instructions.

2.13.9 Interlocking Clay or Cement Tile

Interlocking clay or cement tile shall be installed only over solid sheathing or spaced structural sheathing boards. Interlocking clay or cement tile shall not be installed on roof slopes below one unit vertical in three units horizontal (1:3). Horizontal battens shall be required on roof slopes over one unit vertical in two units horizontal (1:2). Single layer underlayment is required over solid sheathing on all roof slopes. Reinforced underlayment shall be required when spaced sheathing is used. Regardless of roof slope, the first three tile courses and all tiles within 900 mm of roof edges, tiles at changes in roof slope or changes in slope direction, shall be fastened to the roof. For the field of the roof, fastening is not required on roof slopes below one unit vertical in two units horizontal (1:2). Every other tile course shall be fastened on roof slopes 1:2 to less than 1:1; and every tile shall be fastened on roof slopes 1:1 and over. Tile overlap shall be in accordance with approved manufacturer's installation instructions.

2.13.10 Non-interlocking Clay or Cement Tile

Non-interlocking clay or cement tile shall not be installed on roof slopes below one unit vertical in five units horizontal (1:5). Double layer underlayment is required on roof slopes below one unit vertical in four units horizontal (1:4). Single layer underlayment is required on all other roof slopes. Non-interlocking clay or cement tile shall be secured to the roof with two fasteners per tile. The minimum tile overlap shall be 75 mm.

2.13.11 Roof Insulation

Rigid combustible roof insulation shall be permitted, provided the insulation is covered with approved roof coverings directly applied thereto. In-situ lime concrete may be used on flat roofs of buildings. Minimum compacted thickness of such a layer shall be 75 mm and have adequate slope for drainage. The materials used in lime concrete shall conform to the standards specified in Sec 2.5 of this Part.

2.13.12 Recovering and Replacement of Roof Coverings

New roof coverings shall not be installed without first removing existing roof coverings when the existing roof or roof covering is water soaked or has deteriorated to the point that the existing roof or roof covering is not acceptable as a base for additional roofing.

2.13.13 Reuse of Materials

Existing slate, clay or cement tile shall be permitted for reuse, except that damaged, cracked or broken slate or tile shall not be reused. Existing vent flashings, metal edgings, drain outlets, collars and metal counter flashings shall not be reused where rusted, damaged or deteriorated. Aggregate surfacing materials shall not be reused.

2.13.14 Applicable Standards

The applicable Standards for materials used in roofs and roof coverings are listed below:

BDS 868	Code of practice for galvanized corrugated sheet roof and wall coverings.
BDS 1122	Specification for hot-dip galvanized steel and coil.
BDS EN 490	Concrete roofing tiles and fittings for roof covering and all cladding-Product specifications.
BDS EN 491	Concrete roofing tiles and fittings for roof covering and wall cladding-Test methods.
BDS EN 538	Clay roofing tiles for discontinuous laying-Flexural strength test.
BDS EN 539-1	Clay roofing tiles for discontinuous laying Determination of physical characteristics-Part 1: Impermeability test.
BDS EN 1024	Clay roofing tiles for discontinuous laying-Determination of geometric characteristics.
BDS EN 1304	Clay roofing tiles and fittings-Product definitions and specifications.
ASTM A755/A755M	Standard Specification for Steel Sheet, Metallic Coated by the Hot-Dip Process and Pre-painted by the Coil-Coating Process for Exterior Exposed Building Products.
ASTM B101	Standard Specification for Lead-Coated Copper Sheet and Strip for Building Construction.

ASTM C406	Standard Specification for Roofing Slate.
ASTM C836/C836M	Standard Specification for High Solids Content, Cold Liquid-Applied Elastomeric Waterproofing Membrane for Use with Separate Wearing Course.
ASTM C1029	Standard Specification for Spray-Applied Rigid Cellular Polyurethane Thermal Insulation.
ASTM D225	Standard Specification for Asphalt Shingles (Organic Felt) Surfaced With Mineral Granules.
ASTM D226/D226M	Standard Specification for Asphalt-Saturated Organic Felt Used in Roofing and Waterproofing.
ASTM D227	Standard Specification for Coal-Tar-Saturated Organic Felt Used in Roofing and Waterproofing.
ASTM D312	Standard Specification for Asphalt Used in Roofing.
ASTM D450	Standard Specification for Coal-Tar Pitch Used in Roofing, Damp proofing, and Waterproofing.
ASTM D1227	Standard Specification for Emulsified Asphalt Used as a Protective Coating for Roofing.
ASTM D1863	Standard Specification for Mineral Aggregate Used on Built-Up Roofs.
ASTM D2178	Standard Specification for Asphalt Glass Felt Used in Roofing and Waterproofing.
ASTM D2626	Standard Specification for Asphalt-Saturated and Coated Organic Felt Base Sheet Used in Roofing.
ASTM D2898	Standard Practice for Accelerated Weathering of Fire-Retardant-Treated Wood for Fire Testing.
ASTM D3161	Standard Test Method for Wind-Resistance of Asphalt Shingles (Fan-Induced Method).
ASTM D3747	Standard Specification for Emulsified Asphalt Adhesive for Adhering Roof Insulation.
ASTM D3909	Standard Specification for Asphalt Roll Roofing (Glass Felt) Surfaced With Mineral Granules.
ASTM D4272	Standard Test Method for Total Energy Impact of Plastic Films By Dart Drop.

ASTM D4434/D4434M	Standard Specification for Poly (Vinyl Chloride) Sheet Roofing.
ASTM D4601	Standard Specification for Asphalt-Coated Glass Fiber Base Sheet Used in Roofing.
ASTM D4637	Standard Specification for EPDM Sheet Used In Single-Ply Roof Membrane.
ASTM D4897/D4897M	Standard Specification for Asphalt-Coated Glass-Fiber Venting Base Sheet Used in Roofing.
ASTM D6380	Standard Specification for Asphalt Roll Roofing (Organic Felt).
ASTM E108	Standard Test Methods for Fire Tests of Roof Coverings.
ASTM G90	Standard Practice for Performing Accelerated Outdoor Weathering of Nonmetallic Materials Using Concentrated Natural Sunlight.
ASTM G154	Standard Practice for Operating Fluorescent Light Apparatus for UV Exposure of Nonmetallic Materials.
ASTM G155	Standard Practice for Operating Xenon Arc Light Apparatus for Exposure of Non-Metallic Materials.
CGSB (Canadian General Standards Board) 37-GP-56M-80	Membrane, modified bituminous, prefabricated, and reinforced for roofing.
FM 447-86	Approval standard for class I roof coverings.
FM (Factory Manual) 4450-89	Standard laboratories department approved standard for class I insulated steel deck roofs.
RMA (Rubber Manufacturer Association, USA) RP-4-88	Wind design guide for ballasted single-ply roofing systems.
SPRI (Single Ply Roofing Institute, USA) -86	Wind design guide for ballasted single-ply roofing systems.

2.14 Paints and Varnishes

2.14.1 Water Based Paints and Pigments

Water based paints shall conform to the following Standards:

BDS 500	Specification for distemper dry.
BDS 1097	Specification for plastic emulsion paint. Part 1 for Interior use. Part 2 for Exterior use.
IS 427	Specification for distemper, dry, color as required.
IS 428	Specification for distemper, washable.
IS 5410	Specification for cement paint, color as required.
IS 5411	Specification for plastic emulsion paint. Part 1: For interior use. Part 2: For exterior use

2.14.2 Ready Mixed Paints, Enamels and Powder Coatings

Ready mixed paints and enamels shall conform to the following Standards:

BDS 13	Specification for ready mixed paints, varnish, lacquers and related products.
BDS 14	Specification for black bituminous paint, brushing for general purposes.
BDS 397	Specification for ready mixed paint, brushing, red oxide zinc chrome, priming.
BDS 398	Specification for ready mixed paint, spraying, red oxide zinc chrome, priming.
BDS 399	Specification for aluminum paint, spraying for general purposes, in dual container.
BDS 400	Specification for aluminum paint, brushing, for general purposes in dual container.
BDS 401	Specification for varnish, finishing, exterior, type-I, (synthetic).
BDS 402	Specification for ready mixed paint, brushing, finishing, semi-gloss, for general purposes.

BDS 499	Specification for ready mixed paints, brushing, for road marking (white, yellow and black).
BDS 616	Specification for enamel, brushing, exterior (i) undercoating, (ii) finishing, color as required.
BDS 617	Specification for enamel, brushing, interior (i) undercoating, (ii) finishing, color as required.
BDS 926	Specification for ready mixed paint, brushing, petrol resisting, air drying, for exterior painting of containers, color as required.
BDS 927	Specification for ready mixed paint, brushing, petrol resisting, air drying, for interior painting of tanks and containers, red oxide (color unspecified).
BDS 928	Specification for ready mixed paint, brushing, acid resisting, for protection against acid fumes, color as required.
BDS 973	Specification for specification and methods of test for linseed stand oil for paints and varnishes.
BDS 974	Specification and methods of test for raw tung oils for paints and varnishes.
BDS 1005	Specification for ready mixed paint, brushing, finishing, stoving, enamel, color as required.
BDS 1141	Specification for ready mixed aluminum priming paints for woodwork.
BDS 1151	Specification for pavement marking paints.
IS 101	Methods of sampling and test for paints, varnishes and related products: (Part 1/Sec 1): Test on liquid paints (general and physical), Section 1 Sampling. (Part 1/Sec 2): Test on liquid paints (general and physical), Section 2 Preliminary examination and preparation of samples for testing. (Part 1/Sec 3): Test on liquid paints (general and physical), Section 3 Preparation of panels. (Part 1/Sec 4): Test on liquid paints (general and physical), Section 4 Brushing test.

(Part 1/Sec 5): Test on liquid paints (general and physical), Section 5 Consistency.

(Part 1/Sec 6): Test on liquid paints (general and physical), Section 6 Flash point.

(Part 1/Sec 7): Test on liquid paints (general and physical), Section 7 Mass per 10 litres.

(Part 2/Sec 1): Test on liquid paints (chemical examination), Section 1 Water content.

(Part 2/Sec 2): Test on liquid paints (chemical examination), Section 2 Volatile matter.

(Part 3/Sec 1): Tests on paint film formation, Section 1 Drying time.

(Part 3/Sec 2): Tests on paint film formation, Section 2 Film thickness.

(Part 3/Sec 4): Tests on paint film formation, Section 4 Finish.

(Part 3/Sec 5): Tests on paint film formation, Section 5 Fineness of grind

(Part 4/Sec 1): Optical test, Section 1 Opacity.

(Part 4/Sec 2): Optical test, Section 2 Color.

(Part 4/Sec 3): Optical test, Section 3 Light fastness test.

(Part 4/Sec 4): Optical test, Section 4 Gloss.

(Part 5/Sec 1): Mechanical test on paint films, Section 1 Hardness tests.

(Part 5/Sec 2): Mechanical test on paint films, Section 2 Flexibility and adhesion.

(Part 5/Sec 3): Mechanical test on paint films, Section 3 Impact resistance.

(Part 5/Sec 4): Mechanical test on paint films, Section 4 Print free test.

(Part 6/Sec 1): Durability tests, Section 1 Resistance to humidity under conditions of condensation.

(Part 6/Sec 2): Durability tests, Section 2 Keeping properties.

- (Part 6/Sec 3): Durability tests, Section 3 Moisture vapour permeability.
- (Part 6/Sec 4): Durability tests, Section 4 Degradation of coatings (pictorial aids for evaluation).
- (Part 6/Sec 5): Durability tests, Section 5 Accelerated weathering test.
- (Part 7/Sec 1): Environmental tests on paint films, Section 1 Resistance to water.
- (Part 7/Sec 2): Environmental tests on paint films, Section 2 Resistance to liquids.
- (Part 7/Sec 3): Environmental tests on paint films, Section 3 Resistance to heat.
- (Part 7/Sec 4): Environmental tests on paint films, Section 4 Resistance to bleeding of pigments.
- (Part 8/Sec 1): Tests for pigments and other solids, Section 1 Residue on sieve.
- (Part 8/Sec 2): Tests for pigments and other solids, Section 2 Pigments and nonvolatile matter.
- (Part 8/Sec 3): Tests for pigments and other solids, Section 3 Ash content.
- (Part 8/Sec 4): Tests for pigments and other solids, Section 4 Phthalic anhydride.
- (Part 8/Sec 5): Tests for pigments and other solids, Section 5 Lead restriction test.
- (Part 8/Sec 6): Tests for pigments and other solids, Section 6 Volume solids.
- (Part 9/Sec 1): Tests for lacquers and varnish, Section 1 Acid value.
- (Part 9/Sec 2): Tests for lacquers and varnish, Section 2 Rosin test.
- IS 104 Specification for ready mixed paint, brushing, zinc chrome, priming.
- IS 109 Specification for ready mixed paint, brushing, priming, plaster to Indian Standard colors No. 361 and 631.

IS 123	Specification for ready mixed paint, brushing, finishing, semi-gloss, for general purposes, to Indian Standard colors No. 445, 446, 448, 449, 451 and 473; and red oxide (color unspecified).
IS 133	Specification for enamel, interior (a) undercoating, (b) finishing.
IS 137	Specification for ready mixed paint, brushing, matt or egg-shell flat, finishing, interior, to Indian Standard color, as required.
IS 158	Specification for ready mixed paint, brushing, bituminous, black, lead-free, acid, alkali, and heat resisting.
IS 168	Specification for ready mixed paint, air-drying semi-glossy/matt, for general purposes.
IS 341	Specification for black Japan, Types A, B and C.
IS 2074	Specification for ready mixed paint, air drying red oxide-zinc chrome, priming.
IS 2075	Specification for ready mixed paint, stoving, red oxide-zinc chrome, priming.
IS 2339	Specification for aluminum paint for general purposes, in dual container.
IS 2932	Specification for enamel, synthetic, exterior, (a) undercoating, (b) finishing.
IS 2933	Specification for enamel, exterior, (a) undercoating, (b) finishing.
IS 3536	Specification for ready mixed 'paint, brushing, wood primer.
IS 3537	Specification for ready mixed paint, finishing, interior for general purposes, to Indian Standard colors No. 101, 216, 217, 219, 275, 281, 352, 353, 358 to 361, 363, 364, 388, 410, 442, 444, 628, 631, 632, 634, 693, 697, white and black.
IS 3539	Specification for ready mixed paint, undercoating, for use under oil finishes, to Indian Standard colors, as required.
IS 3585	Specification for ready mixed paint, aluminum, brushing, priming, water resistant, for wood work.
IS 3678	Specification for ready mixed paint, thick white, for lettering.
IS 8662	Specification for enamel, synthetic, exterior, (a) undercoating, (b) finishing, for railway coaches.

IS 9862	Specification for ready mixed paint, brushing, bituminous black lead free, acid, alkali, water and chlorine resisting.
IS 11883	Specification for ready mixed paint, brushing, red oxide, priming for metals.
IS 13183	Specification for aluminum paints, heat resistant.
IS 13213	Specification for polyurethane full gloss enamel (two pack).
IS 13607	Specification for ready mixed paint, finishing, general purposes, synthetic.
IS 13871	Specification for powder coatings.

2.14.3 Thinners and Solvents

These shall conform to the following Standards:

IS 324	Specification for ordinary denatured spirit.
IS 82	Methods of sampling and test for thinners and solvents for paints.
IS 324	Specification for ordinary denatured spirit.
IS 533	Specification for gum spirit of turpentine (oil of turpentine).
IS 14314	Specification for thinner general purposes for synthetic paints and varnishes.

2.14.4 Varnishes and Lacquers

These materials shall conform to the following Standards:

BDS 401	Specification for varnish, finishing, exterior, type-I, (synthetic).
BDS 1064	Specification for varnish, stoving.
BDS 1065	Specification for varnish, acid resisting.
BDS 1066	Specification for varnish, finishing, interior.
IS 337	Specification for varnish, finishing, interior.
IS 347	Specification for varnish, shellac for general purposes.
IS 348	Specification for french polish.
IS 524	Specification for varnish, finishing, exterior, synthetic.
IS 525	Specification for varnish, finishing, exterior and general purposes.
IS 642	Specification for varnish medium for aluminum paint.

2.15 Sanitary Appliances and Water Fittings

2.15.1 Sanitary Appliances

Sanitary appliances shall conform to the following Standards:

ASHRAE 90A	Energy conservation in new building design.
ASHRAE 90B	Energy Conservation in New Building Design.
AWWA C700	Cold-Water Meters-Displacement type, bronze main case.
AWWA C701	Cold-Water Meters-Turbine type, for customer service.
AWWA C702	Cold-Water Meters-Compound type.
BDS 1162	Ceramic wash basin and pedestal, ceramic wash basin and pedestals dimension, design & construction, type, permissible deviation
BDS 1163	Specification for Vitreous Sanitary Appliances, Part-1, General requirements. Part-2, Specific requirements for water closets; Part-3, Specification requirements for urinal (bowl type). Part-4, Specific requirements for foot rest. Part-5, Specific requirements for integrated squatting pans.
BDS 1361	Faucets.
BDS 1593	Plastic sanitary squatting pan.
BS 1125	Specification for WC flushing cisterns (including dual flash cisterns and flush pipes).
BS 1244	Metal Sink for domestic purposes.
BS 1254	Specification for C seats (plastics).
BS 1329	Specification for metal hand rinse basins.
BS 1876	Specification for automatic flushing cistern for urinals.

2.15.2 Pipes and Pipe Fittings for Water Supply and Sanitation

Pipes and pipe fittings for water supply and sanitation shall comply with the following Standards :

BDS 1111	Centrifugally cast (spun) iron pressure pipes for water, gas and sewage.
BDS 1356	Specification for ferrules for water services.
BDS 1357	Specification for washers with fittings for water service.
BDS 1361	Faucets. This standard specifies the technical requirements of various types of Faucets.
BDS 1562	Solvent cements for polyvinylchloride (PVC) plastic pipe and fitting.
BDS 1593	Plastic sanitary squatting pan. Pan lays down the requirement for material, dimension physical requirements and testing for power flush type injection molded high density polyethylene (HDPE) or polypropylene (PP) squatting pan.
BDS EN 1254-2	Copper and copper alloys - Plumbing fittings-Part 2: Fittings with compression ends for use with copper tubes.
BDS EN 1717	Protection against pollution of potable water in water installations and general requirements of devices to prevent pollution by backflow.
BDS EN 14506	Devices to prevent pollution by backflow of potable water-Automatic diverter-Family H, type C.
BDS ISO 3419	Non-alloy and alloy steel butt-welding fittings.
BDS ISO 5251	Stainless steel butt-welding fittings.
BDS ISO 6761	Steel tubes-Preparation of ends of tubes and fittings for welding.
BDS ISO 3822-1	Acoustics: Laboratory tests on noise emission from appliances and equipment used in water supply installations-Part 1: Method of measurement.

-
- BDS ISO 3822 -2 Acoustics: Laboratory tests on noise emission from appliances and equipment used in water supply installations-Part 2: Mounting and operating conditions for draw-off taps and mixing valves.
- BDS ISO 3822 -4 Acoustics: Laboratory tests on noise emission from appliances and equipment used in water supply installations-Part 4: Mounting and operating conditions for special appliances.
- BDS ISO 161-1 Thermoplastics pipes for the conveyance of fluids Nominal outside diameters and Nominal Pressures- Part 1: Metric series.
- BDS ISO 161-2 Thermoplastics pipes for the conveyance of fluids- Nominal outside diameters and Nominal Pressures- Part 2: Inch-based series.
- BDS ISO 265-1 Pipes and fittings of plastics materials- fittings for domestic and industrial waste pipes- Basic dimensions: Metric series- Part 1: Un-plasticized Poly (Vinyl chloride) (PVC-U).
- BDS ISO 1167-1 Thermoplastics pipes fittings and assemblies for the conveyance of fluids-Determination of the resistance to internal pressure- Part 1: General method.
- BDS ISO 1167-2 Thermoplastics pipes fittings and assemblies for the conveyance of fluids- Determination of the resistance to internal pressure- Part 2: Preparation of pipe test pieces.
- BDS ISO 1746 Rubber or Plastics hoses and tubing-bending tests.
- BDS ISO 2505 Thermoplastics pipes- Longitudinal reversion-Test method and parameters.
- BDS ISO 2507-2 Thermoplastics pipes and fittings-Vista softening temperature- Part 2: Test conditions for Un-plasticized polyvinylchloride (PVC-U) or chlorinated polyvinylchloride (PVC-C) pipes and fittings and for high impact resistance polyvinylchloride (PVC-HI) pipes.
- BDS ISO 3114 Unplasticized polyvinylchloride (PVC) pipes for potable water supply-Extractability of lead and tin- Test method.

BDS ISO 3126	Plastics piping systems-Plastics components- Determination of dimensions.
BDS ISO 3127	Thermoplastics pipes-Determination of resistance to external blows-round-the-clock method.
BDS ISO 3501	Assembled joints between fittings and polyethylene (PE) pressure pipes-Test of resistance to pull-out.
BDS ISO 3503	Assembled joints between fittings and polyethylene (PE) pressure pipes-Test of leak proofness under internal pressure when subjected to bending.
BDS ISO 3633	Plastics piping systems for soil and waste discharge (low and high temperature) inside buildings-Specifications.
BDS ISO 6964	Polyolefin pipes and fittings-Determination of carbon black content by calcinations and pyrolysis-Test method and basic specification.
BDS ISO 4065	Thermoplastics pipes- Universal wall thickness table.
BDS ISO /TR 4191	Unplasticized polyvinylchloride (PVC-U) pipes for water supply- Recommended practice for laying.
BDS ISO 4422-1	Pipes and fittings made of unplasticized polyvinylchloride (PVC-U) for water supply-Specifications-Part 1: General.
BDS ISO 4422-2	Pipes and fittings made of unplasticized polyvinylchloride (PVC-U) for water supply-Specifications-Part 2: Pipes (with or without integral sockets).
BDS ISO 4422-3	Pipes and fittings made of unplasticized polyvinylchloride (PVC-U) for water supply- Specifications-Part 3: Fittings and joints.
BDS ISO 4422-4	Pipes and fittings made of unplasticized polyvinylchloride (PVC-U) for water supply- Specifications- Part 4: Valves and ancillary equipment.
BDS ISO 4422-5	Pipes and fittings made of unplasticized polyvinylchloride (PVC-U) for water supply- Specifications- Part 5: Fitness for purpose of the system.

BDS ISO 4433-3	Thermoplastics pipes- Resistance to liquid chemicals-Classification-Part 3: Unplasticized polyvinylchloride (PVC-U), high- impact polyvinylchloride (PVC-HI) and chlorinated polyvinylchloride (PVC -C) pipes.
BDS ISO 4435	Plastic piping systems for non- pressure underground drainage and sewerage- Unplasticized polyvinylchloride (PVC-U).
BDS ISO 4439	Unplasticized polyvinylchloride (PVC) pipes and fittings-Determination and specification of density.
BDS ISO 6259-1	Thermoplastics pipes-Determination of tensile properties-Part 1: General test method.
BDS ISO 6259-2	Thermoplastics pipes-Determination of tensile properties- Part 2: Pipes made of unplasticized polyvinylchloride (PVC-U), Chlorinated polyvinylchloride (PVC-C), and high-impact polyvinylchloride (PVC-HI).
BDS ISO 6992	Unplasticized polyvinylchloride (PVC-U) pipes for drinking water supply-Extractability of cadmium and mercury occurring as impurities.
BDS ISO 9624	Thermoplastics pipes for fluids under pressure-Mating dimensions of flange adapters and loose backing flanges.
BDS ISO 11413	Plastics pipes and fittings-Preparation of test piece assemblies between a polyethylene (PE) pipe and an electro fusion fitting BDS ISO 11414, Plastics pipes and fittings-Preparation of polyethylene (PE) pipe/pipe or pipe/fitting test piece assemblies by butt fusion.
BDS ISO 12176-2	Plastics pipes and fittings-Equipment for fusion jointing polyethylene systems-Part 2: Electro fusion
BDS ISO 12176-3	Plastics pipes and fittings-Equipment for fusion jointing polyethylene systems-Part 3: Operator's badge.
BDS ISO 12176-4	Plastics pipes and fittings-Equipment for fusion jointing polyethylene systems-Part 4: Traceability coding.
BDS ISO 13479	Polyolefin pipes for the conveyance of fluids-Determination of resistance to crack propagation-Test method for slow crack growth on notched pipes (notch test).

BDS ISO 13761	Plastics pipes and fittings-Pressure reduction factors for polyethylene pipeline systems for use at temperatures above 20°C.
BDS ISO 13951	Plastics piping systems-Test method for the resistance of polyolefin pipe/pipe or pipe/fitting assemblies to tensile loading.
BDS ISO 13953	Polyethylene (PE) pipes and fittings-Determination of the tensile strength and failure mode of test pieces from a butt-fused joint.
BDS ISO 13954	Plastics pipes and fittings-Peel de-cohesion test for polyethylene (PE) electro fusion assemblies of nominal outside diameter greater than or equal to 90 mm.
BDS ISO 13955	Plastics pipes and fittings-Crushing de-cohesion test for polyethylene (PE) electro fusion assemblies.
BDS ISO 13957	Plastics pipes and fittings-Polyethylene (PE) tapping tees-Test method for impact resistance.
BDS ISO 14236	Plastics pipes and fittings-Mechanical-joint compression fittings for use with polyethylene pressure pipes in water supply systems.
BDS ISO 18553	Method for the assessment of the degree of pigment or carbon black dispersion in polyolefin pipes, fittings and compounds.
BDS ISO 18553	Method for the assessment of the degree of pigment or carbon black dispersion in polyolefin pipes, fittings and compounds Amendment 1:2010.
BDS ISO 4427-1	Plastics piping systems-Polyethylene (PE) pipes and fittings for water supply-Part 1: General.
BDS ISO 4427-2	Plastics piping systems-Polyethylene (PE) pipes and fittings for water supply-Part 2: Pipes.
BDS ISO 4427-3	Plastics piping systems-Polyethylene (PE) pipes and fittings for water supply-Part 3: Fittings.
BDS ISO 4427-5	Plastics piping systems-Polyethylene (PE) pipes and fittings for water supply-Part 5: Fitness for purpose of the system.

BDS ISO 4427-1	Plastics piping systems-Polyethylene (PE) pipes and fittings for water supply-Part 1: General Technical corrigendum 1: 2010.
BDS ISO 3458	Assembled joints between fittings and polyethylene (PE) pressure pipes-Test of leak proofness under internal pressure.
BDS ISO 3459	Polyethylene (PE) pressure pipes-Joints assembled with mechanical fittings-Internal under pressure test method and requirement.
ASTM A53/A53M	Standard Specification for Pipe, Steel, Black and Hot-Dipped, Zinc-Coated, Welded and Seamless.
ASTM A74	Standard Specification for Cast Iron Soil Pipe and Fittings.
ASTM A377	Standard Index of Specifications for Ductile-Iron Pressure Pipe.
ASTM B42	Standard Specification for Seamless Copper Pipe, Standard Sizes.
ASTM B43	Standard Specification for Seamless Red Brass Pipe, Standard Sizes.
ASTM B75	Standard Specification for Seamless Copper Tube.
ASTM B88	Standard Specification for Seamless Copper Water Tube.
ASTM B251	Standard Specification for General Requirements for Wrought Seamless Copper and Copper-Alloy Tube.
ASTM B302	Standard Specification for Thread-less Copper Pipe, Standard Sizes.
ASTM B306	Standard Specification for Copper Drainage Tube (DWV).
ASTM B429/B429M	Standard Specification for Aluminum-Alloy Extruded Structural Pipe and Tube.
ASTM B447	Standard Specification for Welded Copper Tube.
ASTM B745/B745M	Standard Specification for Corrugated Aluminum Pipe for Sewers and Drains.
ASTM C14	Standard Specification for Non-reinforced Concrete Sewer, Storm Drain, and Culvert Pipe.

ASTM C76	Standard Specification for Reinforced Concrete Culvert, Storm Drain, and Sewer Pipe.
ASTM C654	Standard Specification for Porous Concrete Pipe.
ASTM C700	Standard Specification for Vitrified Clay Pipe, Extra Strength, Standard Strength, and Perforated.
ASTM D1527	Standard Specification for Acrylonitrile-Butadiene-Styrene (ABS) Plastic Pipe, Schedules 40 and 80.
ASTM D1785	Standard Specification for Poly(Vinyl Chloride) (PVC) Plastic Pipe, Schedules 40, 80, and 120.
ASTM D2239	Standard Specification for Polyethylene (PE) Plastic Pipe (SIDR-PR) Based on Controlled Inside Diameter.
ASTM D2241	Standard Specification for Poly(Vinyl Chloride) (PVC) Pressure-Rated Pipe (SDR Series).
ASTM D2321	Standard Practice for Underground Installation of Thermoplastic Pipe for Sewers and Other Gravity-Flow Applications ASTM D2464 Standard Specification for Threaded Polyvinyl Chloride (PVC) Plastic Pipe Fittings, Schedule 80.
ASTM D2466	Standard Specification for Polyvinyl Chloride (PVC) Plastic Pipe Fittings, Schedule 40 ASTM D2467 Standard Specification for Poly(Vinyl Chloride) (PVC) Plastic Pipe Fittings, Schedule 80.
ASTM D2609	Standard Specification for Plastic Insert Fittings for Polyethylene (PE) Plastic Pipe.
ASTM D2661	Standard Specification for Acrylonitrile-Butadiene-Styrene (ABS) Schedule 40 Plastic Drain, Waste, and Vent Pipe and Fittings.
ASTM D2665	Standard Specification for Poly(Vinyl Chloride) (PVC) Plastic Drain, Waste, and Vent Pipe and Fittings.
ASTM D2672	Standard Specification for Joints for IPS PVC Pipe Using Solvent Cement.
ASTM D2729	Standard Specification for Poly(Vinyl Chloride) (PVC) Sewer Pipe and Fittings.

ASTM D2737	Standard Specification for Polyethylene (PE) Plastic Tubing.
ASTM D2751	Standard Specification for Acrylonitrile-Butadiene-Styrene (ABS) Sewer Pipe and Fittings.
ASTM D2846/D2846M	Standard Specification for Chlorinated Poly(Vinyl Chloride) (CPVC) Plastic Hot- and Cold-Water Distribution Systems.
ASTM D2949	Standard Specification for 3.25-in. Outside Diameter Poly(Vinyl Chloride) (PVC) Plastic Drain, Waste, and Vent Pipe and Fittings.
ASTM D3034	Standard Specification for Type PSM Poly(Vinyl Chloride) (PVC) Sewer Pipe and Fittings.
ASTM F405	Standard Specification for Corrugated Polyethylene (PE) Pipe and Fittings.
ASTM F409	Standard Specification for Thermoplastic Accessible and Replaceable Plastic Tube and Tubular Fittings.
ASTM F437	Standard Specification for Threaded Chlorinated Poly(Vinyl Chloride) (CPVC) Plastic Pipe Fittings, Schedule 80.
ASTM F438	Standard Specification for Socket-Type Chlorinated Poly(Vinyl Chloride) (CPVC) Plastic Pipe Fittings, Schedule 40.
ASTM B209	Standard Specification for Aluminum and Aluminum-Alloy Sheet and Plate.
ASTM F441/F441M	Standard Specification for Chlorinated Poly(Vinyl Chloride) (CPVC) Plastic Pipe, Schedules 40 and 80.
ASTM F442/F442M	Standard Specification for Chlorinated Poly(Vinyl Chloride) (CPVC) Plastic Pipe (SDR-PR).
ASTM F628	Standard Specification for Acrylonitrile-Butadiene-Styrene (ABS) Schedule 40 Plastic Drain, Waste, and Vent Pipe With a Cellular Core.
ASTM F891	Standard Specification for Coextruded Poly(Vinyl Chloride) (PVC) Plastic Pipe With a Cellular Core.

IS 404 (Part-I)	Specification for lead pipes Part I for other than chemical purpose.
ISO 2531	Ductile Iron pipes, fittings and accessories for pressure pipelines.
ASME/ANSI B16.3	Malleable iron threaded fittings: Classes 150 and 300.
ASME/ANSI B16.485	Cast Iron threaded fittings.
ASME/ANSI B16.9	Factory made wrought steel butt welding fittings.
ASME/ANSI B16.11	Forged Steel Fittings, Socket-Welding and Threaded.
ASME/ABS B16.12	Cast-Iron Threaded Drainage Fittings;
ASME/ANSI B16.15	Cast Copper Alloy Threaded Fittings: Classes 125 and 250.
ASME/ANSI B16.18	Cast Copper Alloy Solder Joint Pressure Fittings.
ASME/ANSI B16.22	Wrought Copper and Copper Alloy Solder Joint Pressure Fittings.
ASME/ANSI B16.23	Cast Copper Alloy Solder Joint Drainage Fittings (DWV).
ASME/ANSI B16.28	Wrought Steel Butt welding Short radius Elbows and Returns.
ASME/ANSI B16.29	Wrought Copper and Wrought Copper Alloy Solder Joint Fittings for solvent Drainage Systems.
ASME/ANSI B16.32	Cast Copper Alloy Solder Joint Fittings for Solvent Drainage Systems.
AWWA C110	Standard for Grey Iron and Ductile Iron Fittings, 76 mm to 1220 mm (3 in. through 48 inches), for Water and Other Liquids.

2.15.3 Joints and Connections Between Pipes and Fittings

Applicable standards for joints and connections between pipes and fittings are listed below:

BDS EN 681-1	Elastomeric seals-Materials requirements for pipe joint seals used in water and drainage applications-Part 1: Vulcanized rubber.
BDS EN 681-2	Elastomeric seals-Materials requirements for pipe joint seals used in water and drainage applications-Part 2: Thermoplastic elastomers.
ASTM B42	Standard Specification for Seamless Copper Pipe, Standard Sizes.
ASTM C425	Standard Specification for Compression Joints for Vitrified Clay Pipe and Fittings.
ASTM C443	Standard Specification for Joints for Concrete Pipe and Manholes, Using Rubber Gaskets.
ASTM C564	Standard Specification for Rubber Gaskets for Cast Iron Soil Pipe and Fittings.
ASTM D2235	Standard Specification for Solvent Cement for Acrylonitrile-Butadiene-Styrene (ABS) Plastic Pipe and Fittings.
ASTM D2564	Standard Specification for Solvent Cements for Poly(Vinyl Chloride) (PVC) Plastic Piping Systems.
ASTM D2657	Standard Practice for Heat Fusion Joining of Polyolefin Pipe and Fittings.
ASTM D2661	Standard Specification for Acrylonitrile-Butadiene-Styrene (ABS) Schedule 40 Plastic Drain, Waste, and Vent Pipe and Fittings.
ASTM D2846/D2846M	Standard Specification for Chlorinated Poly(Vinyl Chloride) (CPVC) Plastic Hot- and Cold-Water Distribution Systems.
ASTM D2855	Standard Practice for Making Solvent-Cemented Joints with Poly(Vinyl Chloride) (PVC) Pipe and Fittings.
ASTM D3139	Standard Specification for Joints for Plastic Pressure Pipes Using Flexible Elastomeric Seals.
ASTM D3212	Standard Specification for Joints for Drain and Sewer Plastic Pipes Using Flexible Elastomeric Seals.

ASTM F402	Standard Practice for Safe Handling of Solvent Cements, Primers, and Cleaners Used for Joining Thermoplastic Pipe and Fittings.
ASTM F493	Standard Specification for Solvent Cements for Chlorinated Poly(Vinyl Chloride) (CPVC) Plastic Pipe and Fittings.
ASTM F628	Standard Specification for Acrylonitrile-Butadiene-Styrene (ABS) Schedule 40 Plastic Drain, Waste, and Vent Pipe With a Cellular Core.
ASTM F656	Standard Specification for Primers for Use in Solvent Cement Joints of Poly(Vinyl Chloride) (PVC) Plastic Pipe and Fittings.
ASME/ANSI B1.20.1	Pillar taps used in water supply.

2.15.4 Taps and Valves

Taps and valves shall conform to the following Standards:

BDS 987	Sand cast brass screw-down bib taps and stop taps for water services. It covers the requirements regarding materials, dimensions, constructions, workmanship, finish and testing of tapes for water services.
BDS 1507	Bib taps used in water supply.
BDS 1508	Stop taps used in water supply specifies the requirements, dimensions construction, materials and test methods of stop taps used in water supply.
BDS 1509	Pillar taps used in water supply.
BDS EN 200	Sanitary tapware-Single taps and combination taps for water supply systems of type 1 and type 2-General technical specification.
BDS EN 246	Sanitary tapware-General specifications for flow rate regulators.

BDS EN 248	Sanitary tapware-General specification for electrodeposited coatings of Ni-Cr.
BDS EN 1112	Sanitary tapware - Shower outlets for sanitary tapware for water supply systems of type 1 and type 2-General technical specification.
BDS EN 1113	Sanitary tapware-Shower hoses for sanitary tapware for water supply systems of type 1 and type 2-General technical specification.
BS 1212 (3 Parts)	Specification for Float Operated Valves (excluding floats).
BS 1010	Specification for draw-off taps and stop valves for water services.
BS 1968	Specification for floats for ball valves (copper).
BS 5433	Specification for underground stop valves for water services (copper).
BS 2456	Specification for floats for ball valves (plastic) for cold and hot water.
BS 1415 (2 parts)	Mixing valves (manually operated).
BS 5163	Specification for predominantly key-operated cast iron wedge gate valve for water works.
BS 3377	Specification for boilers for use with domestic solid mineral fuel appliances.
BS 843	Specification for thermal storage electric water heaters.
BS 855	Specification for welded steel boilers for central heating and indirect hot water supply.

2.16 Miscellaneous Materials

2.16.1 Ferrocement

Details including material requirements are given in Chapter 12 Part 6.

2.16.2 Plastics

Plastics may be used in buildings or structures as light transmitting materials such as glazing, skylights, lighting lenses, luminous ceilings, roof panels, signs and similar purposes. Foam plastics are also used in buildings.

Applicants for approval of a plastic material shall furnish all necessary technical data required by the Building Official. The data shall include chemical composition; applicable physical, mechanical and thermal properties such as fire resistance, flammability and flame spread; weather resistance; electrical properties; products of combustion; and coefficient of expansion.

The requirements for light transmitting plastics, including roof panels and foam plastics are given below.

2.16.2.1 Light Transmitting Plastics

An approved light transmitting plastic shall be any thermoplastic, thermosetting or reinforced thermosetting plastic material which has a self-ignition temperature of 343°C or greater when tested in accordance with, Test Method for Ignition Properties of Plastics; a smoke density rating not greater than 450 when tested in the manner intended for use in accordance with ASTM E84 Test Method for Surface Burning Characteristics of Building Materials; or not greater than 75 when tested in the thickness intended for use in accordance with ASTM D2843 Test Method for Density of Smoke from the Burning or Decomposition of Plastics; and which conforms to one of the following combustibility classifications:

Class C1 : Plastic materials which have a burning extent of 25 mm or less when tested at a nominal thickness of 1.5 mm, or in the thickness intended for use, in accordance with ASTM D635 Test Method for Rate of Burning and/or Extent and Time of Burning of Self-Supporting Plastics in Horizontal Position; or

Class C2: Plastic materials which have a burning rate of 63 mm/min or less when tested at a nominal thickness of 1.5 mm, or in the thickness intended for use, in accordance with ASTM D635.

2.16.2.2 Foam Plastics

All foam plastics and foam plastic cores of manufactured assemblies shall have a flame spread rating of not more than 75 and shall have a smoke developed rating of not more than 450 when tested in the maximum thickness intended for use in accordance with ASTM E84.

All foam plastics, unless otherwise indicated in this Section, shall be separated from the interior of a building by an approved thermal barrier of 13 mm gypsum wall board or equivalent thermal barrier material which will limit the average temperature rise of the unexposed surface to not more than 121°C after 15 minutes of fire exposure complying

with the standard time-temperature curve of ASTM E119 Test Methods for Fire Tests of Building Construction and Materials. The thermal barrier shall be installed in such a manner that it will stay in place for a minimum of 15 minutes under the same testing conditions. The thermal barrier is not required when the foam plastic is protected by a 25 mm minimum thickness of masonry or concrete.

2.16.2.3 Applicable Standards

A list of applicable Standards for plastics is given below:

BDS 885	Method for measuring viscosity number and K-value of PVC resins.
BDS 886	Method for direct measuring the specific gravity of plastics.
BDS 887	Method for measuring deformation under heat of flexible rigid PVC compounds.
BDS 888	Method for measuring temperature of deflection under load.
BDS 889	Method for measuring the Vicat Softening Temperature (VST) of thermoplastics.
BDS 890	Method for measuring the water absorption at room temperature and boiling water absorption of plastics.
BDS 891	Method for measuring the flexural modulus of plastics.
BDS 892	Method for measuring the resistance to tear propagation of flexible plastics, film or sheeting.
ASTM D543	Standard Practices for Evaluating the Resistance of Plastics to Chemical Reagents.
ASTM D635	Standard Test Method for Rate of Burning and/or Extent and Time of Burning of Plastics in a Horizontal Position.
ASTM D638	Standard Test Method for Tensile Properties of Plastics.
ASTM D695	Standard Test Method for Compressive Properties of Rigid Plastics.
ASTM D882	Standard Test Method for Tensile Properties of Thin Plastic Sheeting.

ASTM D1003	Standard Test Method for Haze and Luminous Transmittance of Transparent Plastics.
ASTM D1044	Standard Test Method for Resistance of Transparent Plastics to Surface Abrasion.
ASTM D1204	Standard Test Method for Linear Dimensional Changes of Non-rigid Thermoplastic Sheeting or Film at Elevated Temperature.
ASTM D1593	Standard Specification for Non-rigid Vinyl Chloride Plastic Film and Sheeting.
ASTM D2103	Standard Specification for Polyethylene Film and Sheeting.
ASTM D2126	Standard Test Method for Response of Rigid Cellular Plastics to Thermal and Humid Aging.
ASTM D2842	Standard Test Method for Water Absorption of Rigid Cellular Plastics.
ASTM D2843	Standard Test Method for Density of Smoke from the Burning or Decomposition of Plastics.
ASTM D3294	Standard Specification for PTFE Resin Molded Sheet and Molded Basic Shapes.
ASTM D3678	Standard Specification for Rigid Poly(Vinyl Chloride) (PVC) Interior-Profile Extrusions.
ASTM D3679	Standard Specification for Rigid Poly(Vinyl Chloride) (PVC) Siding.
ASTM D3841	Standard Specification for Glass-Fiber-Reinforced Polyester Plastic Panels.
ASTM D4802	Standard Specification for Poly(Methyl Methacrylate) Acrylic Plastic Sheet.
ASTM E84	Standard Test Method for Surface Burning Characteristics of Building Materials.
ASTM E119	Standard Test Methods for Fire Tests of Building Construction and Materials.

2.16.3 Ballies and Wood Poles

Ballies of Sal/Gazari, Sundari and Garjan are used in building construction. These shall be free from rots, knots and sap, and straight and uniform in size. These should conform to the following Standards:

BDS 809	Specification for wood poles for overhead power and telecommunication lines.
ASTM D25	Standard Specification for Round Timber Piles.
IS 3337	Specification for Ballies for general purposes.
IS 1900	Method of testing wood poles.
IS 6711	Code of practice for maintenance of wood poles for overhead power and telecommunications lines.

2.16.4 Bamboos

The following standards shall be applicable for bamboos used for structural and nonstructural purposes:

IS 1902	Code of Practice for Preservation of Bamboo and Cane for Non-structural Purposes;
IS 6874	Method of Tests for Round Bamboos.
IS 8242	Methods of Tests for Split Bamboo.
IS 8295	Specification for Bamboo Chicks, Part I Fine.
IS 9096	Code of Practice for Preservation of Bamboos for Structural Purposes.

2.16.5 Fillers, Stoppers and Putties

These shall conform to the following standards:

IS 110	Specification for ready mixed paint, brushing, grey filler, for enamels, for use over primers.
IS 345	Specification for wood filler, transparent, liquid.
IS 419	Specification for putty for use on window frames.
IS 421	Specification for jointing paste, for bedding moldings on coaching stock.

IS 423	Specification for plastic wood, for joiners' filler.
IS 424	Specification for plastic asphalt.
IS 3709	Specification for mastic cement for bedding of metal windows.
IS 7164	Specification for Stopper.

2.16.6 Wire Ropes and Wire Products

These materials shall conform to the following standards:

ASTM A116	Standard Specification for Zinc-Coated (Galvanized) Steel Woven Wire Fence Fabric.
ASTM A121	Standard Specification for Metallic-Coated Carbon Steel Barbed Wire.
ASTM A368	Standard Specification for Stainless Steel Wire Strand.
ASTM A392	Standard Specification for Zinc-Coated Steel Chain-Link Fence Fabric.
ASTM A475	Standard Specification for Zinc-Coated Steel Wire Strand.
ASTM A492	Standard Specification for Stainless Steel Rope Wire.
ASTM A510	Standard Specification for General Requirements for Wire Rods and Coarse Round Wire, Carbon Steel.
ASTM A586	Standard Specification for Zinc-Coated Parallel and Helical Steel Wire Structural Strand.
ASTM A603	Standard Specification for Zinc-Coated Steel Structural Wire Rope.
ASTM A817	Standard Specification for Metallic-Coated Steel Wire for Chain-Link Fence Fabric. and Marcellled Tension Wire.
ASTM A824	Standard Specification for Metallic-Coated Steel Marcellled Tension Wire for Use With Chain Link Fence.
ASTM F1183	Standard Specification for Aluminum Alloy Chain Link Fence Fabric.
IS 2365	Specification for Steel Wire Suspension Ropes for Lifts, Elevators and Hoists.

2.16.7 Waterproofing and Damp-proofing Materials

Waterproofing and damp-proofing materials shall conform to the following standards:

ASTM D41	Standard Specification for Asphalt Primer Used in Roofing, Damp proofing, and Waterproofing.
ASTM D43	Standard Specification for Coal Tar Primer Used in Roofing, Damp proofing, and Waterproofing.
ASTM D146	Standard Test Methods for Sampling and Testing Bitumen-Saturated Felts and Woven Fabrics for Roofing and Waterproofing.
ASTM D173	Standard Specification for Bitumen-Saturated Cotton Fabrics Used in Roofing and Waterproofing.
ASTM D6380	Standard Specification for Asphalt Roll Roofing (Organic Felt).
ASTM D226/D226M	Standard Specification for Asphalt-Saturated Organic Felt Used in Roofing and Waterproofing.
ASTM D227	Standard Specification for Coal-Tar-Saturated Organic Felt Used in Roofing and Waterproofing.
ASTM D449	Standard Specification for Asphalt Used in Damp proofing and Waterproofing.
ASTM D450	Standard Specification for Coal-Tar Pitch Used in Roofing, Damp proofing, and Waterproofing.
ASTM D1327	Standard Specification for Bitumen-Saturated Woven Burlap Fabrics Used in Roofing and Waterproofing.
ASTM D1668	Standard Specification for Glass Fabrics (Woven and Treated) for Roofing and Waterproofing.
ASTM D2178	Standard Specification for Asphalt Glass Felt Used in Roofing and Waterproofing.
ASTM D2626	Standard Specification for Asphalt-Saturated and Coated Organic Felt Base Sheet Used in Roofing.
ASTM D3468	Standard Specification for Liquid-Applied Neoprene and Chloro-sulfonated Polyethylene Used in Roofing and Waterproofing.

2.16.8 Glazed Tiles and Tile-setting Mortars

Glazed tiles shall conform to the following standards:

BDS 1301	Specification for glazed earthenware wall tiles.
ASTM C126	Standard Specification for Ceramic Glazed Structural Clay Facing Tile, Facing Brick, and Solid Masonry Units.
ANSI A137.1	Specification for Ceramic Tile.
BS 6431	Ceramic floor and wall tiles (Part 1 to 23).

2.16.8.1 Mortars for Ceramic Wall and Floor Tile

- (a) Portland Cement Mortars: Portland cement mortars for installing ceramic wall and floor tile shall comply with ANSI A108.1 and be of the compositions indicated in Table 5.2.1.
- (b) Dry-set Portland Cement Mortars: Premixed prepared Portland cement mortars, which require only the addition of water and which are used in the installation of ceramic tile, shall comply with ANSI A 118.1. The shear bond strength for tile set in such mortar shall be as required in accordance with that standard. Tile set in dry-set Portland cement mortar shall be installed in accordance with ANSI A 108.5.
- (c) Electrically Conductive Dry-Set Mortars: Premixed prepared Portland cement mortars, which require only the addition of water and which comply with ANSI A118.2, shall be used in the installation of electrically conductive ceramic tile. Tile set in electrically conductive dry-set mortar shall be installed in accordance with ANSI A 108.7.
- (d) Latex-modified Portland Cement Mortars: Latex-modified Portland cement thin set mortars in which Lalex is added to dry-set mortar as a replacement for all or part of the gauging water which are used for the installation of ceramic tile shall comply with ANSI A 118.4. Tile set in latex-modified Portland cement mortar shall be installed in accordance with ANSI A 108.5.
- (e) Epoxy Mortar: Chemical-resistant epoxy for setting and grouting ceramic tile shall comply with ANSI A 118.3-2009. Tile set and grouted with epoxy shall be installed in accordance with ANSI A 108.6.
- (f) Furan Mortar and Grout: Chemical resistant furan mortar and grout which are used to install ceramic tile shall comply with ANSI A 118.5. Tile set and grouted with furan shall be installed in accordance with ANSI A 108.8.

- (g) Modified Epoxy-Emulsion Mortar and Grout: Modified epoxy-emulsion mortar and grout which are used to install ceramic tile shall comply with ANSI A 118.8. Tile set and grouted with modified epoxy-emulsion mortar and grout shall be installed in accordance with ANSI A 108.9.
- (h) Organic Adhesives: Water-resistant organic adhesives used for the installation of ceramic tile shall comply with ANSI A 136.1. The shear bond strength after water immersion shall not be less than 0.25 kN/mm² for Type I adhesive, and not less than 0.13 kN/mm² for Type II adhesive when tested in accordance with ANSI A 136.1. Tile set in organic adhesive shall be installed in accordance with ANSI A 108.4.
- (i) Portland Cement Grouts: Portland cement grouts used for the installation of ceramic tile shall comply with ANSI A 118.6. Portland cement grouts for tile work shall be installed in accordance with ANSI A 108.10.

2.16.8.2 Applicable Standards

A list of applicable Standards for tiles, mortars and adhesives is given below:

BDS 1301	Specification for Glazed Earthenware Wall Tiles.
ASTM C126	Standard Specification for Ceramic Glazed Structural Clay Facing Tile, Facing Brick, and Solid Masonry Units.
ANSI A108.1	Specification for the Installation of Ceramic Tile with Portland Cement Mortar.
ANSI A108.4	Installation of Ceramic Tile with Organic Adhesives or Water Cleanable Tile Setting Epoxy Adhesive.
ANSI A108.5	Installation of Ceramic Tile with Dry-Set Portland Cement Mortar or Latex-Portland Cement Mortar.
ANSI A108.6	Installation of Ceramic Tile with Chemical Resistant, Water Cleanable Tile Setting and Grouting Epoxy.
ANSI A108.7	Specification for Electrically Conductive Ceramic Tile Installed with Conductive Dry-Set Portland Cement Mortar.
ANSI A108.8	Installation of Ceramic Tile with Chemical Resistant Furan Mortar and Grout.
ANSI A108.9	Installation of Ceramic Tile with Modified Epoxy Emulsion Mortar/Grout.

ANSI A108.10	Installation of Grout in Tile work.
ANSI A118.1	Specification for Dry-Set Portland Cement Mortar.
ANSI A118.2	Specifications for Conductive Dry-set Portland Cement Mortar.
ANSI A118.3	Specifications for Chemical Resistant Water Cleanable Tile Setting and Grouting Epoxy and Water Cleanable Tile Setting Epoxy Adhesive.
ANSI A118.4	Specifications Furan Latex-Portland Cement Mortar.
ANSI A118.5	Specifications for Chemical Resistant Furan.
ANSI A118.6	Specifications for Ceramic Tile Grouts.
ANSI A118.8	Specifications for Modified Epoxy Emulsion Mortar/Grout.
ANSI A136.1	Organic Adhesives for Installation of Ceramic Tile.
ANSI A137.1	Specifications for Ceramic Tile.
BS 6431	Floor and wall tiles.
BS 6431 Part 1	Specification for classification and making, including definitions and characteristics.
BS 6431 Part 2	Specification for struded ceramic tiles with low water absorption (E< 3%) Group A1.
BS 6431 Part 3	Extruded ceramic tiles with a water absorption of 3% < 6%. Group A 11a.
BS 6431 Part 3 Sec 3.1	Specification for general products.
BS 6431 Part 3 Sec 3.2	Specification for products Terre Cuite, Cotto, Baldosion Catalan.
BS 6431 Part 4	Extruded Ceramic Tiles with a Water Absorption of 6% <E< 10%. Group A11b.
BS 6431 Part 4	Specification for General Products.
BS 6431 Part 4 Sec 4.2	Specification for Specific Products (Terre Cuite, Cotto, Baldosion Catalan).

BS 6431 Part 5	Specification for extruded ceramic tiles with a water absorption of $E > 10\%$, Group A111.
BS 6431 Part 6	Specification for dust-pre-stressed ceramic tiles with a low-water absorption ($E < 3\%$) Group B1.
BS 6431 Part 7	Specification for dust-pre-stressed ceramic tiles with a water absorption of $3\% < E \leq 6\%$ Group B11a;
BS 6431 Part 8	Specification for dust-pre-stressed ceramic tiles with water absorption of $6\% < E \leq 10\%$. Group B11b;
BS 6431 Part 9	Specification for dust-pre-stressed ceramic tiles with a water absorption of $E > 10\%$. Group B111.
BS 6431 Part 10	Method for determination of dimensions and surface quality.
BS 6431 Part 11	Method for determination of water absorption.
BS 6431 Part 12	Method for determination of modulus of.
BS 6431 Part 13	Method for determination of scratch hardness of surface according to Mhos.
BS 6431 Part 14	Method for determination of resistance to abrasion of unglazed tiles.
BS 6431 Part 15	Method for determination of linear thermal expansion.
BS 6431 Part 16	Method for determination of resistance to thermal shock.
BS 6431 Part 17	Method for determination of crazing resistance-glazed tiles.
BS 6431 Part 18	Method for determination of chemical resistance-unglazed tiles.
BS 6431 Part 19	Method for determination of chemical resistance-glazed tiles.
BS 6431 Part 20	Method for determination of resistance to surface abrasion-glazed tiles.
BS 6431 Part 23	Specification for sampling and basis for acceptance.

2.16.9 Refractories

Refractories shall conform to the following Standards:

BDS 1493	Glossary of terms used in refractory.
BDS 1494	Dimension of refractory bricks.
BDS 1495	High aluminum refractory bricks.
ISO 528	Refractory products-determination of pyrometric cone equivalent (refractoriness).
ISO 1109	Refractory products-classification of dense shaped refractory products.
ISO 1146	Pyrometric reference cones for laboratory use-specification.
ISO 1893	Refractory products-determination of refractoriness-under-load (differential with rising temperature).
ISO 1927	Prepared unshaped refractory materials (dense and insulating) classification.
ISO 2245	Shaped insulating refractory products-classification.
ISO 2477	Shaped insulating refractory products-determination of permanent change in dimensions on heating.
ISO 2478	Dense shaped refractory products-determination of permanent change in dimensions on heating.
ISO 3187	Refractory products-determination of creep in compression.
ISO 5013	Refractory products-determination of modulus of rupture at elevated temperatures.
ISO 5014	Refractory products-determination of modulus of rupture at ambient temperature.
ISO 5016	Shaped insulating refractory products-determination of bulk density and true porosity.
ISO 5017	Dense shaped refractory products-determination of bulk density, apparent porosity and true porosity.
ISO 5018	Refractory materials-determination of true density.

ISO 5019-1	Refractory bricks-dimensions-Part 1: Rectangular bricks.
ISO 5019-2	Refractory bricks-dimensions-Part 2: Arch bricks;
ISO 5019-3	Refractory bricks-dimensions-Part 3: Rectangular checker bricks for regenerative furnace.
ISO 5419-4	Refractory bricks-dimensions-Part 4: Dome bricks for electric arc furnace roofs.
ISO 5015-6	Refractory bricks-dimensions-Part 6: Basic bricks for oxygen steel making converters.
ISO 5022	Shaped refractory products-sampling and acceptance testing.
ISO 5417	Refractory bricks for use in rotary kilns-dimensions.
ISO 8656	Refractory products-sampling of raw materials and unshaped products- Part 1: Sampling scheme.
ISO 8840	Refractory materials-determination of bulk density of granular materials (grain density).
ISO 8890	Dense shaped refractory products-determination of resistance to sulfuric acid.
ISO 8894-1	Refractory materials-determination of thermal conductivity- Part 1: Hot-wire method (cross-array).
ISO 8894-2	Refractory materials-determination of thermal conductivity- Part 2: Hot-wire method (parallel).
ISO 8895	Shaped Insulating refractory products-determination of cold crushing strength.
ISO 9205	Refractory bricks for use in rotary kilns-hot-face identification marking.
ISO 10080	Refractory products-classification of dense, shaped acid-resisting products.
ISO 10081	Basic refractory products-classification- Part I: Products containing less than 7% residual carbon.

2.16.10 Thermal Insulating Materials

Thermal insulation may be in the following physical forms:

- Loose fill dry granules or nodules poured or below in place;
- Flexible or semi rigid blankets and bolts of wool like material;
- Rigid boards and blocks;
- Membrane reflective insulation;
- Spray applied mineral fibre or insulating concrete;
- Poured in plain-insulating concrete;
- Foamed in place-polyurethane;
- Gypsum plaster.

Thermal insulating materials shall conform to the Standards listed below:

ASTM C167	Standard Test Methods for Thickness and Density of Blanket or Batt Thermal Insulations.
ASTM C177	Standard Test Method for Steady-State Heat Flux Measurements and Thermal Transmission Properties by Means of the Guarded-Hot-Plate Apparatus.
ASTM C195	Standard Specification for Mineral Fiber Thermal Insulating Cement.
ASTM C196	Standard Specification for Expanded or Exfoliated Vermiculite Thermal Insulating Cement
ASTM C208	Standard Specification for Cellulosic Fiber Insulating Board.
ASTM C209	Standard Test Methods for Cellulosic Fiber Insulating Board.
ASTM C1363	Standard Test Method for Thermal Performance of Building Materials and Envelope Assemblies by Means of a Hot Box Apparatus.
ASTM C240	Standard Test Methods of Testing Cellular Glass Insulation Block.
ASTM C335	Standard Test Method for Steady-State Heat Transfer Properties of Pipe Insulation.

ASTM C411	Standard Test Method for Hot-Surface Performance of High-Temperature Thermal Insulation.
ASTM C449	Standard Specification for Mineral Fiber Hydraulic-Setting Thermal Insulating and Finishing Cement.
ASTM C516	Standard Specification for Vermiculite Loose Fill Thermal Insulation.
ASTM C518	Standard Test Method for Steady-State Thermal Transmission Properties by Means of the Heat Flow Meter Apparatus.
ASTM C520	Standard Test Methods for Density of Granular Loose Fill Insulations.
ASTM C533	Standard Specification for Calcium Silicate Block and Pipe Thermal Insulation.
ASTM C534/C534M	Standard Specification for Preformed Flexible Elastomeric Cellular Thermal Insulation in Sheet and Tubular Form.
ASTM C547	Standard Specification for Mineral Fiber Pipe Insulation.
ASTM C549	Standard Specification for Perlite Loose Fill Insulation.
ASTM C552	Standard Specification for Cellular Glass Thermal Insulation.
ASTM C553	Standard Specification for Mineral Fiber Blanket Thermal Insulation for Commercial and Industrial Applications.
ASTM C578	Standard Specification for Rigid, Cellular Polystyrene Thermal Insulation.
ASTM C591	Standard Specification for Un-faced Preformed Rigid Cellular Polyisocyanurate Thermal Insulation.
ASTM C592	Standard Specification for Mineral Fiber Blanket Insulation and Blanket-Type Pipe Insulation (Metal-Mesh Covered) (Industrial Type).
ASTM C610	Standard Specification for Molded Expanded Perlite Block and Pipe Thermal Insulation.
ASTM C612	Standard Specification for Mineral Fiber Block and Board Thermal Insulation.
ASTM C665	Standard Specification for Mineral-Fiber Blanket Thermal Insulation for Light Frame Construction and Manufactured Housing.

ASTM C726	Standard Specification for Mineral Fiber Roof Insulation Board.
ASTM C728	Standard Specification for Perlite Thermal Insulation Board.
ASTM C739	Standard Specification for Cellulosic Fiber Loose-Fill Thermal Insulation.
ASTM C764	Standard Specification for Mineral Fiber Loose-Fill Thermal Insulation.
ASTM C916	Standard Specification for Adhesives for Duct Thermal Insulation.
ASTM C991	Standard Specification for Flexible Fibrous Glass Insulation for Metal Buildings.
ASTM C1014	Standard Specification for Spray-Applied Mineral Fiber Thermal and Sound Absorbing Insulation.
ASTM C1029	Standard Specification for Spray-Applied Rigid Cellular Polyurethane Thermal Insulation.
ASTM C1071	Standard Specification for Fibrous Glass Duct Lining Insulation (Thermal and Sound Absorbing Material).

2.16.11 Screw Threads and Rivets

These shall conform to the following standards:

IS 554	Dimensions for pipe threads where pressure tight joints are required on the threads.
IS 1929	Specification for hot forged steel rivets for hot closing (12 to 36 mm diameter).
IS 2155	Specification for cold-forged solid steel rivets for hot closing (6 to 16 mm diameter).
IS 2643	Dimensions for pipe threads for fastening purposes. Part I-Basic profile and dimensions. Part II-Tolerances. Part III-Limits of sizes.
IS 2907	Specification for non-ferrous rivets (1.6 mm to 10 mm).
IS 2998	Specification for cold forged steel rivets for cold closing (1 to 16 mm diameter).
IS 10102	Technical supply conditions for rivets.

2.16.12 Sealants

Sealants shall conform to the following Standards:

ASTM C509	Standard Specification for Elastomeric Cellular Preformed Gasket and Sealing Material.
ASTM C542	Standard Specification for Lock-Strip Gaskets.
ASTM C564	Standard Specification for Rubber Gaskets for Cast Iron Soil Pipe and Fittings.
ASTM C716	Standard Specification for Installing Lock-Strip Gaskets and Infill Glazing Materials.
ASTM C719	Standard Test Method for Adhesion and Cohesion of Elastomeric Joint Sealants Under Cyclic Movement (Hockman Cycle).
ASTM C1193	Standard Guide for Use of Joint Sealants.
ASTM C794	Standard Test Method for Adhesion-in-Peel of Elastomeric Joint Sealants.
ASTM C834	Standard Specification for Latex Sealants.
ASTM C864	Standard Specification for Dense Elastomeric Compression Seal Gaskets, Setting Blocks, and Spacers.
ASTM C919	Standard Practice for Use of Sealants in Acoustical Applications.
ASTM C920	Standard Specification for Elastomeric Joint Sealants.
ASTM C1193	Standard Guide for Use of Joint Sealants.
ASTM D2628	Standard Specification for Preformed Polychloroprene Elastomeric Joint Seals for Concrete Pavements.
ASTM D6690	Standard Specification for Joint and Crack Sealants, Hot Applied, for Concrete and Asphalt Pavements.
ASTM D3406	Standard Specification for Joint Sealant, Hot-Applied, Elastomeric-Type, for Portland Cement Concrete Pavements.
ASTM D3667	Standard Specification for Rubber Seals Used in Flat-Plate Solar Collectors.
ASTM D3771	Standard Specification for Rubber Seals Used in Concentrating Solar Collectors.

ASTM D3832	Standard Specification for Rubber Seals Contacting Liquids in Solar Energy Systems.
ISO 3934	Rubber building gaskets-materials in preformed solid vulcanizates used for sealing glazing and panels-specification.
ISO 4633	Rubber seals-joint rings for water supply, drainage and sewerage pipelines-specifications for materials
ISO 4635	Rubber, vulcanized-preformed compression seals for use between concrete motorway paving sections-specifications for material.
ISO 5892	Rubber Building Gaskets-Materials for Preformed Solid Vulcanized Structural Gaskets-Specification;
ISO 6447	Rubber seals-joint rings used for gas supply pipes and fittings-specification for material.
ISO 9331	Rubber seals joint rings for hot water supply pipelines up to 110° C specifications for the material.

2.16.13 Joints and Jointing Products

Joints and jointing products shall conform to the following Standards:

ISO 2444	Joints in buildings-vocabulary.
ISO 3867	Agglomerated cork-material of expansion joints for construction and building test-methods.
ISO 3869	Agglomerated cork-filler material of expansion joints for construction and buildings -characteristics, sampling and packing.
ISO 3934	Rubber building gaskets-materials in preformed solid vulcanizates used for sealing glazing and panels-specification.
ISO 4633	Rubber seals-joint rings for water supply, drainage and sewerage pipelines-specification for materials.
ISO 4635	Rubber, vulcanized-preformed compression seals for use between concrete motor way paving sections-specification for material.
ISO 5892	Rubber building gaskets-materials for preformed solid vulcanized structural gaskets-specification.

ISO 6447	Rubber seals-joint rings used for gas supply pipes and fittings-specification for material.
ISO 6589	Joints in building-laboratory method of test for air permeability of joints.
ISO 7389	Building construction-jointing products-determination of elastic recovery.
ISO 7390	Building construction-jointing products-determination of resistance to flow.
ISO 7727	Joints in building-principles for jointing of building components-accommodation of dimensional deviations during construction.
ISO 8339	Building construction-jointing products-sealants-determination of tensile properties.
ISO 8340	Building construction-jointing products-sealants-determination of tensile properties at maintained extension.
ISO 8394	Building construction-jointing products-determination of extrudability of one-component sealants.
ISO 9046	Building construction-sealants-determination of adhesion/ cohesion properties at constant temperature.
ISO 9047	Building construction-sealants-determination of adhesion/ cohesion properties at variable temperatures.
ISO 9631	Rubber seals-joint rings for hot water supply pipelines up to 110°C specifications for the material.
ISO 10563	Building construction-sealants for joints-determination of change in mass and volume.
ISO 10590	Building construction-sealants-determination of adhesion/cohesion properties at maintained extension after immersion in water.
ISO 10591	Building construction-sealants-determination of adhesion/cohesion properties after immersion in water.

2.16.14 Glass and Glazing

The applicable Standards for glass and glazing are listed below:

ASTM C1036	Standard Specification for Flat Glass.
ASTM C1048	Standard Specification for Heat-Treated Flat Glass-Kind HS, Kind FT Coated and Uncoated Glass.
ANSI Z 97.1	Safety Performance Specifications and Methods of Tests for Transport Safety Glazing Materials Used in Building.
CPSC 16 CFR	Safety Standard for Architectural Glazing Materials. Part 1201A.

2.17 Cgi Sheet Roofing and Walling

Galvanized corrugated steel sheets conforming to BDS 868, Galvanized Corrugated Sheet Roof and Wall Coverings, may be used over structural framing for construction of roofs and walls. Requirements for various roofing materials including CGI sheet have been specified in Sec 2.13 above.

Part VI
Chapter 1
Definitions and General Requirements

1.1 Introduction

1.1.1 Scope

The definitions providing meanings of different terms and general requirements for the structural design of buildings, structures, and components thereof are specified in this Chapter. These requirements shall apply to all buildings and structures or their components regulated by this Code. All anticipated loads required for structural design shall be determined in accordance with the provisions of Chapter 2. Design parameters required for the structural design of foundation elements shall conform to the provisions of Chapter 3. Design of structural members using various construction materials shall comply with the relevant provisions of Chapters 4 to 13. The FPS equivalents of the empirical expressions used throughout Part 6 are listed in Appendix A.

This Code shall govern in all matters pertaining to design, construction, and material properties wherever this Code is in conflict with requirements contained in other standards referenced in this Code. However, in special cases where the design of a structure or its components cannot be covered by the provisions of this Code, other relevant internationally accepted codes referred in this Code may be used.

1.1.2 Definitions

The following definitions shall provide the meaning of certain terms used in this Chapter.

BASE SHEAR	Total design lateral force or shear at the base of a structure.
BASIC WIND SPEED	Three-second gust speed at 10 m above the mean ground level in terrain Exposure-B defined in Sec 2.4.6 and associated with an annual probability of occurrence of 0.02.
BEARING WALL SYSTEM	A structural system without a complete vertical load carrying space frame.
BRACED FRAME	An essentially vertical truss system of the concentric or eccentric type which is provided to resist lateral forces.
BUILDING FRAME SYSTEM	An essentially complete space frame which provides support for loads.

CONCENTRIC BRACED FRAME (CBF)	A steel braced frame designed in conformance with Sec 10.20.13 or Sec 10.20.14.
COLLECTOR	A member or element used to transfer lateral forces from a portion of a structure to the vertical elements of the lateral force resisting elements.
DEAD LOAD	The load due to the weight of all permanent structural and nonstructural components of a building or a structure, such as walls, floors, roofs and fixed service equipment.
DIAPHRAGM	A horizontal or nearly horizontal system acting to transmit lateral forces to the vertical resisting elements. The term "diaphragm" includes horizontal bracing systems.
DUAL SYSTEM	A combination of Moment Resisting Frames and Shear Walls or Braced Frames to resist lateral loads designed in accordance with the criteria of Sec 1.3.2.4.
ECCENTRIC BRACED FRAME (EBF)	A steel braced frame designed in conformance with Sec 10.20.15.
HORIZONTAL BRACING SYSTEM	A horizontal truss system that serves the same function as a floor or roof diaphragm.
INTERMEDIATE MOMENT FRAME (IMF)	A concrete moment resisting frame designed in accordance with Sec 8.3.10.
LIVE LOAD	The load superimposed by the use and occupancy of a building.
MOMENT RESISTING FRAME	A frame in which members and joints are capable of resisting forces primarily by flexure.
ORDINARY MOMENT FRAME (OMF)	A moment resisting frame not meeting special detailing requirements for ductile behaviour.
PRIMARY FRAMING SYSTEM	That part of the structural system assigned to resist lateral forces.
SHEAR WALL	A wall designed to resist lateral forces parallel to the plane of the wall (sometimes referred to as a vertical diaphragm or a structural wall).

SLENDER BUILDINGS AND STRUCTURES	Buildings and structures having a height exceeding five times the least horizontal dimension, or having a fundamental natural frequency less than 1 Hz. For those cases where the horizontal dimensions vary with height, the least horizontal dimension at mid height shall be used.
SOFT STOREY	A soft storey is one in which the lateral stiffness is less than 70 percent of that in the storey above or less than 80 percent of the average stiffness of the three storeys above.
SPACE FRAME	A three-dimensional structural system without bearing walls composed of members interconnected so as to function as a complete self-contained unit with or without the aid of horizontal diaphragms or floor bracing systems.
SPECIAL MOMENT FRAME (SMF)	A moment resisting frame specially detailed to provide ductile behaviour complying with the requirements of Chapter 8 or 10 for concrete or steel frames respectively.
SPECIAL STRUCTURAL SYSTEM	A structural system not listed in Table 6.1.3 and specially designed to carry the lateral loads. (See Sec 1.3.2.5).
STOREY	The space between any two floor levels including the roof of a building. Storey-x is the storey below level x.
STOREY SHEAR, V_x	The summation of design lateral forces above the storey under consideration.
STRENGTH	The usable capacity of an element or a member to resist the load as prescribed in these provisions.
TERRAIN	The ground surface roughness condition when considering the size and arrangement of obstructions to the wind.
THREE-SECOND GUST SPEED	The highest average wind speed over a 3 second duration at a height of 10 m. The three-second gust speed is derived using Durst's model in terms of the mean wind speed and turbulence intensity.
TOWER	A tall, slim vertical structure.
VERTICAL LOAD-CARRYING FRAME	A space frame designed to carry all vertical gravity loads.
WEAK STOREY	Storey in which the lateral strength is less than 80 percent of that of the storey above.

1.1.3 Symbols and Notation

The following symbols and notation shall apply to the provisions of this Chapter:

D	=	Dead load on a member including self-weight and weight of components, materials and permanent equipment supported by the member
E	=	Earthquake load
F_i	=	Lateral force applied at level – i of a building
h	=	Height of a building or a structure above ground level in metres
h_i, h_n, h_x	=	Height in metres above ground level to level – i , – n or – x respectively
level – i	=	i^{th} level of a structure above the base; $i = 1$ designates the first level above the base
level – n	=	Upper most level of a structure
level – x	=	x^{th} level of a structure above the base; $x = 1$ designates the first level above the base.
L	=	Live load due to intended use or occupancy
l	=	Span of a member or component.
M_x	=	Overturning moment at level – x
V	=	Total design lateral force or shear at the base
V_x	=	Storey shear at storey level – x
R	=	Response modification or reduction coefficient for structural system given in Table 6.2.19 for seismic design.
T	=	Fundamental period of vibration in seconds
W	=	Load due to wind pressure.
W'	=	Weight of an element or component
Z	=	Seismic zone coefficient given in Figure 6.2.24 or Table 6.2.14 or Table 6.2.15
Δ	=	Storey lateral drift.

1.2 Basic Considerations

1.2.1 General

All buildings and structures shall be designed and constructed in conformance with the provisions of this Section. The buildings and portions thereof shall support all loads including dead load specified in this Chapter and elsewhere in this Code. Impact, fatigue and self-straining forces shall be considered where these forces occur.

1.2.2 Buildings and Structures

A structure shall ordinarily be described as an assemblage of framing members and components arranged to support both gravity and lateral forces. Structures may be classified as building and non-building structures. Structures that enclose a space and are used for various occupancies shall be called buildings or building structures. Structures other than buildings, such as water tanks, bridges, communication towers, chimneys etc., shall be called non-building structures. When used in conjunction with the word building(s), the word structure(s) shall mean non-building structures, e.g. 'buildings and structures' or 'buildings or structures'. Otherwise the word 'structures' shall include both buildings and non-building structures.

1.2.3 Building and Structure Occupancy Categories

Buildings and other structures shall be classified, based on the nature of occupancy, according to Table 6.1.1 for the purposes of applying flood, surge, wind and earthquake provisions. The occupancy categories range from I to IV, where Occupancy Category I represents buildings and other structures with a low hazard to human life in the event of failure and Occupancy Category IV represents essential facilities. Each building or other structure shall be assigned to the highest applicable occupancy category or categories. Assignment of the same structure to multiple occupancy categories based on use and the type of load condition being evaluated (e.g., wind or seismic) shall be permissible.

When buildings or other structures have multiple uses (occupancies), the relationship between the uses of various parts of the building or other structure and the independence of the structural systems for those various parts shall be examined. The classification for each independent structural system of a multiple-use building or other structure shall be that of the highest usage group in any part of the building or other structure that is dependent on that basic structural system.

Table 6.1.1: Occupancy Category of Buildings and other Structures for Flood, Surge, Wind and Earthquake Loads.

Nature of Occupancy	Occupancy Category
Buildings and other structures that represent a low hazard to human life in the event of failure, including, but not limited to: <ul style="list-style-type: none"> • Agricultural facilities • Certain temporary facilities • Minor storage facilities 	I
All buildings and other structures except those listed in Occupancy Categories I, III and IV	II
Buildings and other structures that represent a substantial hazard to human life in the event of failure, including, but not limited to: <ul style="list-style-type: none"> • Buildings and other structures where more than 300 people congregate in one area • Buildings and other structures with day care facilities with a capacity greater than 150 • Buildings and other structures with elementary school or secondary school facilities with a capacity greater than 250 • Buildings and other structures with a capacity greater than 500 for colleges or adult education facilities • Healthcare facilities with a capacity of 50 or more resident patients, but not having surgery or emergency Treatment facilities • Jails and detention facilities 	III
Buildings and other structures, not included in Occupancy Category IV, with potential to cause a substantial economic impact and/or mass disruption of day-to-day civilian life in the event of failure, including, but not limited to: <ul style="list-style-type: none"> • Power generating stations^a • Water treatment facilities • Sewage treatment facilities • Telecommunication centers 	
Buildings and other structures not included in Occupancy Category IV (including, but not limited to, facilities that manufacture, process, handle, store, use, or dispose of such substances as hazardous fuels, hazardous chemicals, hazardous waste, or explosives) containing sufficient quantities of toxic or explosive substances to be dangerous to the public if released.	

Buildings and other structures designated as essential facilities, including, but not limited to: IV

- Hospitals and other healthcare facilities having surgery or emergency treatment facilities
- Fire, rescue, ambulance, and police stations and emergency vehicle garages
- Designated earthquake, hurricane, or other emergency shelters
- Designated emergency preparedness, communication, and operation centers and other facilities required for emergency response
- Power generating stations and other public utility facilities required in an emergency
- Ancillary structures (including, but not limited to, communication towers, fuel storage tanks, cooling towers,
- Electrical substation structures, fire water storage tanks or other structures housing or supporting water, or other fire-suppression material or equipment) required for operation of Occupancy Category IV structures during an emergency
- Aviation control towers, air traffic control centers, and emergency aircraft hangars
- Community water storage facilities and pump structures required to maintain water pressure for fire suppression
- Buildings and other structures having critical national defense functions

Buildings and other structures (including, but not limited to, facilities that manufacture, process, handle, store, use, or dispose of such substances as hazardous fuels, hazardous chemicals, or hazardous waste) containing highly toxic substances where the quantity of the material exceeds a threshold quantity established by the authority having jurisdiction.

^a Cogeneration power plants that do not supply power on the national grid shall be designated Occupancy Category II

1.2.4 Safety

Buildings, structures and components thereof, shall be designed and constructed to support all loads, including dead loads, without exceeding the allowable stresses or specified strengths (under applicable factored loads) for the materials of construction in the structural members and connections.

1.2.5 Serviceability

Structural framing systems and components shall be designed with adequate stiffness to have deflections, vibration, or any other deformations within the serviceability limit of building or structure. The deflections of structural members shall not exceed the more restrictive of the limitations provided in Chapters 2 through 13 or that permitted by Table 6.1.2 or the notes that follow. For wind and earthquake loading, story drift and sway shall be limited in accordance with the provisions of Sec 1.5.6. In checking the serviceability, the load combinations and provisions of Sec 2.7.5 shall be followed.

Table 6.1.2: Deflection Limits^{a, b, c, h} (Except earthquake load)

Construction	L	W^f	$D^g + L^d$
Roof members: ^c			
Supporting plaster ceiling	$l/360$	$l/360$	$l/240$
Supporting non-plaster ceiling	$l/240$	$l/240$	$l/180$
Not supporting ceiling	$l/180$	$l/180$	$l/120$
Floor members	$l/360$	-	$l/240$
Exterior walls and interior partitions			
With brittle finishes	-	$l/240$	
With flexible finishes	-	$l/120$	
Farm buildings	-		$l/180$
Greenhouses	-		$l/120$

Where, l , L , W and D stands for span of the member under consideration, live load, wind load and dead load respectively.

Notes:

- a. For structural roofing and siding made of formed metal sheets, the total load deflection shall not exceed $l/60$. For secondary roof structural members supporting formed metal roofing, the live load deflection shall not exceed $l/150$. For secondary wall members supporting formed metal siding, the design wind load deflection shall not exceed $l/90$. For roofs, this exception only applies when the metal sheets have no roof covering.

- b.* Interior partitions not exceeding 2 m in height and flexible, folding and portable partitions are not governed by the provisions of this Section.
 - c.* For cantilever members, l shall be taken as twice the length of the cantilever.
 - d.* For wood structural members having a moisture content of less than 16% at time of installation and used under dry conditions, the deflection resulting from $L + 0.5D$ is permitted to be substituted for the deflection resulting from $L + D$.
 - e.* The above deflections do not ensure against ponding. Roofs that do not have sufficient slope or camber to assure adequate drainage shall be investigated for ponding. See Sec 1.6.5 for rain and ponding requirements.
 - f.* The wind load is permitted to be taken as 0.7 times the “component and cladding” loads for the purpose of determining deflection limits herein.
 - g.* Deflection due to dead load shall include both instantaneous and long term effects.
 - h.* For aluminum structural members or aluminum panels used in skylights and sloped glazing framing, roofs or walls of sunroom additions or patio covers, not supporting edge of glass or aluminum sandwich panels, the total load deflection shall not exceed $l/60$. For continuous aluminum structural members supporting edge of glass, the total load deflection shall not exceed $l/175$ for each glass lite or $l/60$ for the entire length of the member, whichever is more stringent. For aluminum sandwich panels used in roofs or walls of sunroom additions or patio covers, the total load deflection shall not exceed $l/120$.
-

1.2.6 Rationality

Structural systems and components thereof shall be analyzed, designed and constructed based on rational methods which shall include, but not be limited to the provisions of Sec 1.2.7.

1.2.7 Analysis

Analysis of the structural systems shall be made for determining the load effects on the resisting elements and connections, based on well-established principles of mechanics taking equilibrium, geometric compatibility and both short and long term properties of the construction materials into account and incorporating the following:

1.2.7.1 Mathematical model

A mathematical model of the physical structure shall represent the spatial distribution of stiffness and other properties of the structure which is adequate to provide a complete load path capable of transferring all loads and forces from their points of origin to the load-resisting elements for obtaining various load effects. For dynamic analysis, mathematical model shall also incorporate the appropriately distributed mass and damping properties of the structure adequate for the determination of the significant features of its dynamic response. All buildings and structures shall be thus analyzed preferably using a three dimensional computerized model incorporating these features of mathematical model. It is essential to use three dimensional computer model to represent a structure having irregular plan configuration as mentioned in Sec 1.3.4.2 and having rigid or semirigid floor and roof diaphragms. Requirements for two-dimensional model and three dimensional models for earthquake analysis are described in Sections 2.5.11 to 2.5.14.

1.2.7.2 Loads and forces

All prescribed loads and forces to be supported by the structural systems shall be determined in accordance with the applicable provisions of this Chapter and Chapter 2. Loads shall be applied on the mathematical model specified in Sec. 1.2.7.1 at appropriate spatial locations and along desired directions.

1.2.7.3 Soil-structure interaction

Soil-structure interaction effects, where required, shall be included in the analysis by appropriately including the properly substantiated properties of soil into the mathematical model specified in Sec. 1.2.7.1 above.

1.2.8 Distribution of Horizontal Shear

The total lateral force shall be distributed to the various elements of the lateral force-resisting system in proportion to their rigidities considering the rigidity of the horizontal bracing systems or diaphragms.

1.2.9 Horizontal Torsional Moments

Structural systems and components shall be designed to sustain additional forces resulting from torsion due to eccentricity between the centre of application of the lateral forces and the centre of rigidity of the lateral force resisting system. Forces shall not be decreased due to torsional effects. For accidental torsion effects on seismic forces, requirements shall conform to Sec 2.5.7.6.

1.2.10 Stability Against Overturning and Sliding

Every building or structure shall be designed to resist the overturning and sliding effects caused by the lateral forces specified in this Chapter.

1.2.11 Anchorage

Anchorage of the roof to wall and columns, and of walls and columns to foundations, shall be provided to resist the uplift and sliding forces resulting from the application of the prescribed loads. Additional requirements for masonry or concrete walls shall be those given in Sec 1.7.3.6.

1.2.12 General Structural Integrity

Buildings and structural systems shall possess general structural integrity that is the ability to sustain local damage caused due to misuse or accidental overloading, with the structure as a whole remaining stable and not being damaged to an extent disproportionate to the original local damage.

1.2.13 Proportioning of Structural Elements

Structural elements, components and connections shall be proportioned and detailed based on the design methods provided in the subsequent Chapters for various materials of construction, such as reinforced concrete, masonry, steel etc. to resist various load effects obtained from a rational analysis of the structural system.

1.2.14 Walls and Framing

Walls and structural framing shall be erected true to plumb in accordance with the design. Interior walls, permanent partitions and temporary partitions exceeding 1.8 m of height shall be designed to resist all loads to which they are subjected. If not otherwise specified elsewhere in this Code, walls shall be designed for a minimum load of 0.25 kN/m² applied perpendicular to the wall surfaces. The deflection of such walls under a load of 0.25 kN/m² shall not exceed $\frac{1}{240}$ of the span for walls with brittle finishes and $\frac{1}{120}$ of the span for walls with flexible finishes. However, flexible, folding or portable partitions shall not be required to meet the above load and deflection criteria, but shall be anchored to the supporting structure.

1.2.15 Additions to Existing Structures

When an existing building or structure is extended or otherwise altered, all portions thereof affected by such cause shall be strengthened, if necessary, to comply with the safety and serviceability requirements provided in Sections 1.2.4 and 1.2.5 respectively.

1.2.16 Phased Construction

When a building or structure is planned or anticipated to undergo phased construction, structural members therein shall be investigated and designed for any additional stresses arising due to such construction.

1.2.17 Load Combinations and Stress Increase

Every building, structure, foundation or components thereof shall be designed to sustain, within the allowable stress or specified strength (under factored load), the most unfavourable effects resulting from various combinations of loads specified in Sec 2.7. Except otherwise permitted or restricted by any other Sections of this Code, maximum increase in the allowable stress shall be 33% when allowable or working stress method of design is followed. For soil stresses due to foundation loads, load combinations and stress increase specified in Sec 2.7.2 for allowable stress design method shall be used.

1.3 Structural Systems

1.3.1 General

Every structure shall have one of the basic structural systems specified in Sec 1.3.2 or a combination thereof. The structural configuration shall be as specified in Sec 1.3.4 with the limitations imposed in Sec 2.5.5.4.

1.3.2 Basic Structural Systems

Structural systems for buildings and other structures shall be designated as one of the types A to G listed in Table 6.1.3. Each type is again classified as shown in the Table by the types of vertical elements used to resist lateral forces. A brief description of different structural systems are presented in following sub-sections.

1.3.2.1 Bearing wall system

A structural system having bearing walls/bracing systems without a complete vertical load carrying frame to support gravity loads. Resistance to lateral loads is provided by shear walls or braced frames.

1.3.2.2 Building frame system

A structural system with an essentially complete space frame providing support for gravity loads. Resistance to lateral loads is provided by shear walls or braced frames separately.

1.3.2.3 Moment resisting frame system

A structural system with an essentially complete space frame providing support for gravity loads. Moment resisting frames also provide resistance to lateral load primarily by flexural action of members, and may be classified as one of the following types:

- (a) Special Moment Frames (SMF)
- (b) Intermediate Moment Frames (IMF)
- (c) Ordinary Moment Frames (OMF).

The framing system, IMF and SMF shall have special detailing to provide ductile behaviour conforming to the provisions of Sections 8.3 and 10.20 of Part 6 for concrete and steel structures respectively. OMF need not conform to these special ductility requirements of Chapter 8 or 10.

Table 6.1.3: Basic Structural Systems

A. BEARING WALL SYSTEMS (no frame)
1. Special reinforced concrete shear walls
2. Ordinary reinforced concrete shear walls
3. Ordinary reinforced masonry shear walls
4. Ordinary plain masonry shear walls
B. BUILDING FRAME SYSTEMS (with bracing or shear wall)
1. Steel eccentrically braced frames, moment resisting connections at columns away from links
2. Steel eccentrically braced frames, non-moment-resisting, connections at columns away from links
3. Special steel concentrically braced frames
4. Ordinary steel concentrically braced frames
5. Special reinforced concrete shear walls
6. Ordinary reinforced concrete shear walls
7. Ordinary reinforced masonry shear walls
8. Ordinary plain masonry shear walls

C. MOMENT RESISTING FRAME SYSTEMS (no shear wall)

1. Special steel moment frames
 2. Intermediate steel moment frames
 3. Ordinary steel moment frames
 4. Special reinforced concrete moment frames
 5. Intermediate reinforced concrete moment frames
 6. Ordinary reinforced concrete moment frames
-

D. DUAL SYSTEMS: SPECIAL MOMENT FRAMES CAPABLE OF RESISTING AT LEAST 25% OF PRESCRIBED SEISMIC FORCES (with bracing or shear wall)

1. Steel eccentrically braced frames
 2. Special steel concentrically braced frames
 3. Special reinforced concrete shear walls
 4. Ordinary reinforced concrete shear walls
-

E. DUAL SYSTEMS: INTERMEDIATE MOMENT FRAMES CAPABLE OF RESISTING AT LEAST 25% OF PRESCRIBED SEISMIC FORCES (with bracing or shear wall)

1. Special steel concentrically braced frames
 2. Special reinforced concrete shear walls
 3. Ordinary reinforced masonry shear walls
 4. Ordinary reinforced concrete shear walls
-

F. DUAL SHEAR WALL-FRAME SYSTEM: ORDINARY REINFORCED CONCRETE MOMENT FRAMES AND ORDINARY REINFORCED CONCRETE SHEAR WALLS

G. STEEL SYSTEMS NOT SPECIFICALLY DETAILED FOR SEISMIC RESISTANCE

1.3.2.4 Dual system

A structural system having a combination of the following framing systems:

- (a) Moment resisting frames (SMF, IMF or steel OMF), and
- (b) Shear walls or braced frames.

The two systems specified in (a) and (b) above shall be designed to resist the total lateral force in proportion to their relative rigidities considering the interaction of the dual system at all levels. However, the moment resisting frames shall be capable of resisting at least 25% of the applicable total seismic lateral force, even when wind or any other lateral force governs the design.

1.3.2.5 Special structural system

A structural system not defined above nor listed in Table 6.1.3 and specially designed to carry the lateral loads, such as tube-in-tube, bundled tube, etc.

1.3.2.6 Non-building structural system

A structural system used for purposes other than in buildings and conforming to Sections 1.5.4.8, 1.5.4.9, 2.4 and 2.5 of Part 6.

1.3.3 Combination of Structural Systems

When different structural systems of Sec 1.3.2 are combined for incorporation into the same structure, design of the combined seismic force resisting system shall conform to the provisions of Sec 2.5.5.5.

1.3.4 Structural Configurations

Based on the structural configuration, each structure shall be designated as a regular or irregular structure as defined below:

1.3.4.1 Regular structures

Regular structures have no significant physical discontinuities or irregularities in plan or vertical configuration or in their lateral force resisting systems. Typical features causing irregularity are described in Sec 1.3.4.2.

1.3.4.2 Irregular structures

Irregular structures have either vertical irregularity or plan irregularity or both in their structural configurations or lateral force resisting systems.

1.3.4.2.1 Vertical irregularity

Structures having one or more of the irregular features listed in Table 6.1.4 shall be designated as having a vertical irregularity.

1.3.4.2.2 Plan irregularity

Structures having one or more of the irregular features listed in Table 6.1.5 shall be designated as having a plan irregularity.

Table 6.1.4: Vertical Irregularities of Structures

Vertical Irregularity Type	Definition	Reference Section
I	a. Stiffness Irregularity (Soft Storey): Soft storey is one in which the lateral stiffness is less than 70 percent of that in the storey above or less than 80 percent of the average stiffness of the three storeys above.	1.7.3.8, 2.5.5 to 2.5.14 and
	b. Stiffness Irregularity (Extreme Soft Storey): Extreme soft storey irregularity is defined to exist where there is a story in which the lateral stiffness is less than 60% of that in the story above or less than 70% of the average stiffness of the three stories above.	2.5.17
II	Mass Irregularity: Mass irregularity shall be considered to exist where the effective mass of any storey is more than 150 percent of the effective mass of an adjacent storey. A roof which is lighter than the floor below need not be considered.	2.5.5 to 2.5.14
III	Vertical Geometric Irregularity: Vertical geometric irregularity shall be considered to exist where horizontal dimension of the lateral force-resisting system in any storey is more than 130 percent of that in an adjacent storey, one-storey penthouses need not be considered.	2.5.5 to 2.5.14
IV	In-Plane Discontinuity in Vertical Lateral Force-Resisting Element: An in-plane offset of the lateral load-resisting elements greater than the length of those elements.	1.7.3.8, 2.5.5 to 2.5.14
Va	Discontinuity in Capacity (Weak Storey): A weak storey is one in which the storey strength is less than 80 percent of that in the storey above. The storey strength is the total strength of all seismic-resisting elements sharing the storey shear for the direction under consideration.	2.5.5 to 2.5.14 and 2.5.17
Vb	Extreme Discontinuity in Capacity (Very Weak Storey): A very weak storey is one in which the storey strength is less than 65 percent of that in the storey above.	2.5.5 to 2.5.14 and 2.5.17

Table 6.1.5: Plan (Horizontal) Irregularities of Structures

Plan Irregularity Type	Definition	Reference Section
I	<p>Torsional Irregularity (to be considered when diaphragms are not flexible):</p> <p>a. Torsional irregularity shall be considered to exist when the maximum storey drift, computed including accidental torsion, at one end of the structure is more than 1.2 times the average of the storey drifts at the two ends of the structure.</p> <p>b. Extreme Torsional Irregularity is defined to exist where the maximum story drift, computed including accidental torsion, at one end of the structure transverse to an axis is more than 1.4 times the average of the story drifts at the two ends of the structure. Extreme torsional irregularity requirements in the reference sections apply only to structures in which the diaphragms are rigid or semirigid.</p>	1.7.3.8, 2.5.5 to 2.5.14
II	<p>Reentrant Corners:</p> <p>Plan configurations of a structure and its lateral force-resisting system contain reentrant corners, where both projections of the structure beyond a reentrant corner are greater than 15 percent of the plan dimension of the structure in the given direction.</p>	1.7.3.8, 2.5.5 to 2.5.14
III	<p>Diaphragm Discontinuity:</p> <p>Diaphragms with abrupt discontinuities or variations in stiffness, including those having cutout or open areas greater than 50 percent of the gross enclosed area of the diaphragm, or changes in effective diaphragm stiffness of more than 50 percent from one storey to the next.</p>	1.7.3.8, 2.5.5 to 2.5.14
IV	<p>Out-of-plane Offsets:</p> <p>Discontinuities in a lateral force path, such as out-of-plane offsets of the vertical elements.</p>	1.7.3.8, 2.5.5 to 2.5.14
V	<p>Nonparallel Systems:</p> <p>The vertical lateral load-resisting elements are not parallel to or symmetric about the major orthogonal axes of the lateral force-resisting system.</p>	2.5.5 to 2.5.15

1.4 Design For Gravity Loads

1.4.1 General

Design of buildings and components thereof for gravity loads shall conform to the requirements of this Section. Gravity loads, such as dead load and live loads applied at the floors or roof of a building shall be determined in accordance with the provisions of Chapter 2 of this Part.

1.4.2 Floor Design

Floor slabs and decks shall be designed for the full dead and live loads as specified in Sections 2.2 and 2.3 respectively. Floor supporting elements such as beams, joists, columns etc. shall be designed for the full dead load and the appropriately reduced live loads set forth by the provisions of Sec 2.3.13. Design of floor elements shall also conform to the following provisions:

- (a) Uniformly Distributed Loads: Where uniform floor loads are involved, consideration may be limited to full dead load on all spans in combination with full live load on adjacent spans and on alternate spans to determine the most unfavourable effect of stresses in the member concerned.
- (b) Concentrated Loads: Provision shall be made in designing floors for a concentrated load as set forth in Sec 2.3.5 applied at a location wherever this load acting upon an otherwise unloaded floor would produce stresses greater than those caused by the uniform load required therefore.
- (c) Partition Loads: Loads due to permanent partitions shall be treated as a dead load applied over the floor as a uniform line load having intensity equal to the weight per metre run of the partitions as specified in Sec 2.2.5. Loads for light movable partitions shall be determined in accordance with the provisions of Sec 2.3.6.
- (d) Design of Members: Floor members, such as slabs or decks, beams, joists etc. shall be designed to sustain the worst effect of the dead plus live loads or any other load combinations as specified in Sec 2.7. Where floors are used as diaphragms to transmit lateral loads between various resisting elements, those loads shall be determined following the provisions of Sec 1.7.3.8. Detailed design of the floor elements shall be performed using the procedures provided in Chapters 4 to 13 of Part 6 for various construction materials.
- (e) Floors and associated structural members shall have adequate strength and stiffness to prevent undesirable vibration due to human activity (e.g walking, dancing, jumping, sporting activities etc.) or vibration caused by machines which causes discomfort to the occupants and which is detrimental to the safety, integrity and durability of the structure.

1.4.3 Roof Design

Roofs and their supporting elements shall be designed to sustain, within their allowable stresses or specified strength limits, all dead loads and live loads as set out by the provisions of Sections 2.2 and 2.3 respectively. Design of roof members shall also conform to the following requirements:

- (a) Application of Loads: When uniformly distributed loads are considered for the design of continuous structural members, load including full dead loads on all spans in combination with full live loads on adjacent spans and on alternate span, shall be investigated to determine the worst effects of loading. Concentrated roof live loads and special roof live loads, where applicable, shall also be considered in design.
- (b) Unbalanced Loading: Effects due to unbalanced loads shall be considered in the design of roof members and connections where such loading will result in more critical stresses. Trusses and arches shall be designed to resist the stresses caused by uniform live loads on one half of the span if such loading results in reverse stresses, or stresses greater in any portion than the stresses produced by this unit live load when applied upon the entire span.
- (c) Rain Loads: Roofs, where ponding of rain water is anticipated due to blockage of roof drains, excessive deflection or insufficient slopes, shall be designed to support such loads. Loads on roofs due to rain shall be determined in accordance with the provisions of Sec 2.6.2. In addition to the dead load of the roof, either the roof live load or the rain load, whichever is of higher intensity, shall be considered in design.

1.4.4 Reduction of Live Loads

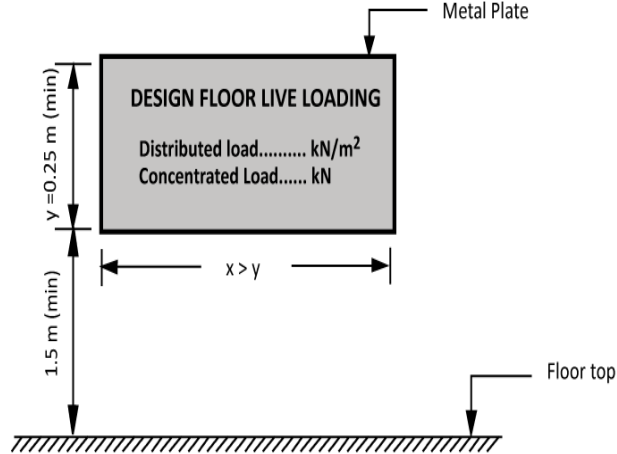
The design live loads specified in Sec 2.3, may be reduced to appropriate values as permitted by the provisions of Sections 2.3.13 and 2.3.14.

1.4.5 Posting of Live Loads

In every building, of which the floors or parts thereof have a design live load of 3.5 kN/m² or more, and which are used as library stack room, file room, parking garage, machine or plant room, or used for industrial or storage purposes, the owner of the building shall ensure that the live loads for which such space has been designed, are posted on durable metal plates as shown in Figure 6.1.1, securely affixed in a conspicuous place in each space to which they relate. If such plates are lost, removed, or defaced, owner shall be responsible to have them replaced.

1.4.6 Restrictions on Loading

The building owner shall ensure that the live load for which a floor or roof is or has been designed, will not be exceeded during its use.



- Notes : (1) Minimum dimension of metal sign plate shall be 0.25 m
 (2) Minimum size of lettering shall be 25 mm
 (3) Minimum distance of the bottom of plate from floor top shall be 1.5 m
 (4) Letterings shall be of metal embossed or cast on a metal plate
 (5) Plate shall be securely affixed in a conspicuous place to which it relates.

Figure 6.1.1 Sample live load sign

1.4.7 Special Considerations

In the absence of actual dead and live load data, the minimum values of these loads shall be those specified in Sections 2.2 and 2.3. In addition, special consideration shall be given to the following aspects of loading and due allowances shall be made in design if occurrence of such loading is anticipated after construction of a building:

- (a) Increase in Dead Load: Actual thickness of the concrete slabs or other members may become larger than the designed thickness due to movements or deflections of the formwork during construction.
- (b) Future Installations: Changes in the numbers, types and positions of partitions and other installations may increase actual load on the floors of a building.
- (c) Occupancy Changes: Increase in live loads due to changes of occupancy involving loads heavier than that being designed for.

1.4.8 Deflection and Camber

Structural systems and members thereof shall be designed to have adequate stiffness to limit deflections. The deflections of structural members shall not exceed the more restrictive of the limitations of Chapters 2 to 13 of this Part or that permitted by Table 6.1.2. or provisions of Sec 1.2.5 of this Chapter. In calculating deflections due to gravity loads, long term effects (e.g. creep, shrinkage or stress relaxation) should also be considered.

1.5 Design For Lateral Loads

1.5.1 General

Every building, structure or portions thereof shall be designed to resist the lateral load effects, such as those due to wind or earthquake forces, in compliance with the requirements prescribed in this Section.

1.5.2 Selection of Lateral Force for Design

Any of the lateral loads prescribed in Chapter 2, considered either alone or in combination with other forces, whichever produces the most critical effect, shall govern the design. However, the structural detailing requirements shall comply with those prescribed in Sec 1.7 of this Chapter. When a dual structural system is used to resist lateral loads, design shall also conform to Sec 1.3.2.4 of this Chapter.

1.5.3 Design for Wind Load

Design of buildings and their components to resist wind induced forces shall comply with the following requirements:

1.5.3.1 Direction of wind

Structural design for wind forces shall be based on assumption that wind may blow from any horizontal direction.

1.5.3.2 Design considerations

Design wind load on the primary framing systems and components of a building or structure shall be determined on the basis of the procedures provided in Sec 2.4 Chapter 2 Part 6 considering the basic wind speed, shape and size of the building, and the terrain exposure condition of the site. For slender buildings and structures, dynamic response characteristics, such as fundamental natural frequency, shall be determined to estimate gust response coefficient. Load effects, such as forces, moments, and deflections etc. on various components of building due to wind shall be determined from static analysis of the structure as specified in Sec 1.2.7.1 of this Chapter.

1.5.3.3 Shielding effect

Reductions in wind pressure on buildings and structures due to apparent direct shielding effects of the up wind obstructions, such as man-made constructions or natural terrain features, shall not be permitted.

1.5.3.4 Dynamic effects

Dynamic wind forces such as that from along-wind vibrations caused by the dynamic wind-structure interaction effects, as set forth by the provisions of Sec 2.4.8 Chapter 2 Part 6, shall be considered in the design of regular shaped slender buildings. For other dynamic effects such as cross-wind or torsional responses as may be experienced by buildings or structures having unusual geometrical shapes (i.e. vertical or plan irregularities listed in Tables 6.1.4 and 6.1.5), response characteristics, or site locations, structural design shall be made based on the information obtained either from other reliable references or from wind-tunnel test specified in Sec 1.5.3.5 below, complying with the other requirements of this Section.

1.5.3.5 Wind tunnel test

Properly conducted wind-tunnel tests shall be required for those buildings or structures having unusual geometric shapes, response characteristics, or site locations for which cross-wind response such as vortex shedding, galloping etc. warrant special consideration, and for which no reliable literature for the determination of such effects is available. This test is also recommended for those buildings or structures for which more accurate wind-loading information is desired than those given in this Section and in Sec 2.4. Tests for the determination of mean and fluctuating components of forces and pressures shall be considered to be properly conducted only if the following requirements are satisfied:

- (a) The natural wind has been modelled to account for the variation of wind speed with height,
- (b) The intensity of the longitudinal components of turbulence has been taken into consideration in the model,
- (c) The geometric scale of the structural model is not more than three times the geometric scale of the longitudinal component of turbulence,
- (d) The response characteristics of the wind tunnel instrumentation are consistent with the measurements to be made, and
- (e) The Reynolds number is taken into consideration when determining forces and pressures on the structural elements.

Tests for the purpose of determining the dynamic response of a structure shall be considered to be properly conducted only if requirements (a) through (e) above are fulfilled and, in addition, the structural model is scaled with due consideration to length, distribution of mass, stiffness and damping of the structure.

1.5.3.6 Wind loads during construction

Buildings, structures and portions thereof under construction, and construction structures such as formwork, staging etc. shall be provided with adequate temporary bracings or other lateral supports to resist the wind load on them during the erection and construction phase.

1.5.3.7 Masonry construction in high-wind regions

Design and construction of masonry structures in high-wind regions shall conform to the requirements of relevant Sections of Chapter 7 Part 6.

1.5.3.8 Height limits

Unless otherwise specified elsewhere in this Code, no height limits shall be imposed, in general, on the design and construction of buildings or structures to resist wind induced forces.

1.5.4 Design for Earthquake Forces

Design of structures and components thereof to resist the effects of earthquake forces shall comply with the requirements of this Section.

1.5.4.1 Basic design consideration

For the purpose of earthquake resistant design, each structure shall be placed in one of the seismic zones as given in Sec 2.5.4.2 and assigned with a structure importance category as set forth in Sec 2.5.5.1. The seismic forces on structures shall be determined considering seismic zoning, site soil characteristics, structure importance, structural systems and configurations, height and dynamic properties of the structure as provided in Sec 2.5. The structural system and configuration types for a building or a structure shall be determined in accordance with the provisions of Sec 2.5.5.4. Other seismic design requirements shall be those specified in this Section.

1.5.4.2 Requirements for directional effects

The directions of application of seismic forces used in the design shall be those which will produce the most critical load effects. Earthquake forces act in both principal directions of the building simultaneously. Design provisions for considering earthquake component in orthogonal directions have been provided in Sec 2.5.13.1.

1.5.4.3 Structural system and configuration requirements

Seismic design provisions impose the following limitations on the use of structural systems and configurations:

- (a) The structural system used shall satisfy requirements of the Seismic Design Category (defined in Sec. 2.5.5.2) and height limitations given in Sec 2.5.5.4.
- (b) Structures assigned to Seismic Design Category D having vertical irregularity Type Vb of Table 6.1.4 shall not be permitted. Structures with such vertical irregularity may be permitted for Seismic Design Category B or C but shall not be over two stories or 9 m in height.
- (c) Structures having irregular features described in Table 1.3.2 or Table 1.3.3 shall be designed in compliance with the additional requirements of the Sections referenced in these Tables.
- (d) Special Structural Systems defined in Sec 1.3.2.5 may be permitted if it can be demonstrated by analytical and test data to be equivalent, with regard to dynamic characteristics, lateral force resistance and energy absorption, to one of the structural systems listed in Table 6.2.19, for obtaining an equivalent R and C_d value for seismic design.

1.5.4.4 Methods of analysis

Earthquake forces and their effects on various structural elements shall be determined by using either a static analysis method or a dynamic analysis method whichever is applicable based on the limitations set forth in Sections 2.5.5 to 2.5.12 and conforming to Sec 1.2.7.

1.5.4.5 Minimum design seismic force

The minimum design seismic forces shall be those determined in accordance with the Sections 2.5.5 to 2.5.14 whichever is applicable.

1.5.4.6 Distribution of seismic forces

The total lateral seismic forces and moments shall be distributed among various resisting elements at any level and along the vertical direction of a building or structure in accordance with the provisions of Sections 2.5.5 to 2.5.12 as appropriate.

1.5.4.7 Vertical components of seismic forces

Design provisions for considering vertical component of earthquake ground motion is given in Sec 2.5.13.2

1.5.4.8 Height limits

Height limitations for different structural systems are given in Table 6.2.19 of Sec 2.5.3.4 Chapter 2 Part 6 of this Code as a function of seismic design category.

1.5.4.9 Non-building structures

Seismic lateral force on non-building structures shall be determined in accordance with the provisions of ASCE 7: Minimum Design Loads for Buildings and other Structures. However, provisions of ASCE 7 may be simplified, consistent with the provisions of Sec 2.5 Part 6 of this Code. Other design requirements shall be those provided in this Chapter.

1.5.5 Overturning Requirements

Every structure shall be designed to resist the overturning effects caused by wind or earthquake forces specified in Sections 2.4 and 2.5 respectively as well other lateral forces like earth pressure, tidal surge etc. The overturning moment M_x at any storey level- x of a building shall be determined as:

$$M_x = \sum_{i=1}^n F_i (h_i - h_x) \quad (6.1.1)$$

Where,

h_i, h_x, h_n = Height in metres at level- $i, -x$ or $-n$ respectively.

F_i = Lateral force applied at level- $i, i = 1$ to n .

At any level, the increment of overturning moment shall be distributed to the various resisting elements in the same manner as the distribution of horizontal shear prescribed in Sec 2.5.7.5. Overturning effects on every element shall be carried down to the foundation level.

1.5.6 Drift and Building Separation

1.5.6.1 Storey drift limitation

Storey drift is the horizontal displacement of one level of a building or structure relative to the level above or below due to the design gravity (dead and live loads) or lateral forces (e.g. wind and earthquake loads). Calculated storey drift shall include both translational and torsional deflections and conform to the following requirements:

- (a) Storey drift, Δ , for loads other than earthquake loads, shall be limited as follows:

$$\Delta \leq 0.005h \quad \text{for } T < 0.7 \text{ second}$$

$$\Delta \leq 0.004h \quad \text{for } T \geq 0.7 \text{ second}$$

$$\Delta \leq 0.0025h \quad \text{for unreinforced masonry structures.}$$

Where, h = height of floor. The period T used in this calculation shall be the same as that used for determining the base shear in Sec 2.5.7.2.

- (b) The drift limits set out in (a) above may be exceeded where it can be demonstrated that greater drift can be tolerated by both structural and nonstructural elements without affecting life safety.
- (c) For earthquake loads, the story drift, Δ shall be limited in accordance with the limits set forth in Sec 2.5.14.1

1.5.6.2 Sway limitation

The overall sway (horizontal deflection) at the top level of the building or structure due to wind loading shall not exceed $\frac{1}{500}$ times the total height of the building above ground, in accordance with Sec 2.7.5.

1.5.7 Building Separation

All components of a structure shall be designed and constructed to act as an integral unit unless they are separated structurally by a distance sufficient to avoid contact under the most unfavorable condition of deflections due to lateral loads. For seismic loads, design guidelines are given in Sec 2.5.14.3.

1.5.8 P-Delta Effects

The resulting member forces and moments and the storey drifts induced by P-Delta effects need not be considered when the stability coefficient (θ) remains within 0.10. This coefficient (described in Sec 2.5.7.9) may be evaluated for any storey as the product of the total vertical dead and live loads above the storey and the lateral drift in that storey divided by the product of the storey shear in that storey and the height of that storey.

1.5.9 Uplift Effects

Uplift effects caused due to lateral loads shall be considered in design. When allowable (working) stress method is used for design, dead loads used to reduce uplift shall be multiplied by a factor of 0.85.

1.6 Design For Miscellaneous Loads

1.6.1 General

Buildings, structures and components thereof, when subject to loads other than dead, live, wind and earthquake loads, shall be designed in accordance with the provisions of this Section. Miscellaneous loads, such as those due to temperature, rain, flood and surge etc. on buildings or structures, shall be determined in accordance with Sec

2.6. Structural members subject to miscellaneous loads, not specified in Sec 2.6 shall be designed using well established methods given in any reliable references, and complying with the other requirements of this Code.

1.6.2 Self-Straining Forces

Self-straining forces such as those arising due to assumed differential settlements of foundations and from restrained dimensional changes due to temperature, moisture, shrinkage, creep, and similar effects, shall be taken into consideration in the design of structural members.

1.6.3 Stress Reversal and Fatigue

Structural members and joints shall be investigated and designed against possible stress reversals caused due to various construction loads. Where required, allowance shall be made in the design to account for the effects of fatigue. The allowable stress may be appropriately reduced to account for such effects in the structural members.

1.6.4 Flood, Tidal/Storm Surge and Tsunami

Buildings, structures and components thereof shall be designed, constructed and anchored to resist flotation, collapse or any permanent movement due to loads including flood, tidal/Storm surge and tsunami, when applicable. Structural members shall be designed to resist both hydrostatic and significant hydrodynamic loads and effects of buoyancy resulting from flood or surge. Flood and surge loads on buildings and structures shall be determined in accordance with Sec 2.6.3. Load combination including flood and surge loads shall conform to Sec 2.7. Design of foundations to sustain these load effects shall conform to the provisions of Sec 1.8.

Stability against overturning and sliding caused due to wind and flood or surge loads simultaneously shall be investigated, and such effects shall be resisted with a minimum factor of safety of 1.5, considering dead load only.

1.6.5 Rain Loads

Roofs of the buildings and structures as well as their other components which may have the capability of retaining rainwater shall be designed for adequate gravity load induced by ponding. Roofs and such other components shall be analysed and designed for load due to ponding caused by accidental blockage of drainage system complying with Sec. 2.6.2.

1.6.6 Other Loads

Buildings and structures and their components shall be analyzed and designed for stresses caused by the following effects:

- (a) Temperature Effects (Sec 2.6.4).
- (b) Soil and Hydrostatic Pressure (Sec 2.6.5).
- (c) Impacts and Collisions
- (d) Explosions (Sec 2.6.6).
- (e) Fire
- (f) Vertical Forces on Air Raid Shelters (Sec 2.6.7).
- (g) Loads on Helicopter Landing Areas (Sec 2.6.8).
- (h) Erection and Construction Loads (Sec 2.6.9).
- (i) Moving Loads for Crane Movements
- (j) Creep and Shrinkage
- (k) Dynamic Loads due to Vibrations
- (l) Construction Loads

Design of buildings and structures shall include loading and stresses caused by the above effects in accordance with the provisions set forth in Chapter 2.

1.7 Detailed Design Requirements

1.7.1 General

All structural framing systems shall comply with the requirements of this Section. Only the elements of the designated lateral force resisting systems can be used to resist design lateral forces specified in Chapter 2. The individual components shall be designed to resist the prescribed forces acting on them. Design of components shall also comply with the specific requirements for the materials contained in Chapters 4 to 13. In addition, such framing systems and components shall comply with the design requirements provided in this Section.

1.7.2 Structural Framing Systems

The basic structural systems are defined in Sec 1.3.2 and shown in Table 6.1.3, and each type is subdivided by the types of framing elements used to resist the lateral forces. The structural system used shall satisfy requirements of seismic design category and height limitations indicated in Table 6.2.19. Special framing requirements are given in the following Sections in addition to those provided in Chapters 4 to 13.

1.7.3 Detailing Requirements for Combinations of Structural Systems

For components common to different structural systems, a more restrictive detailing shall be provided.

1.7.3.1 Connections to resist seismic forces

Connections which resist prescribed seismic forces shall be designed in accordance with the seismic design requirements provided in Chapters 4 to 13. Detailed sketches for these connections shall be given in the structural drawings.

1.7.3.2 Deformation compatibility

All framing elements not required by design to be part of the lateral force resisting system, shall be investigated and shown to be adequate for vertical load carrying capacity when subjected to lateral displacements resulting from the seismic lateral forces. For designs using working stress methods, this capacity may be determined using an allowable stress increase of 30 percent. Geometric non-linear (*P-Delta*) effects on such elements shall be accounted for.

- (a) Adjoining Rigid Elements : Moment resisting frames may be enclosed or adjoined by more rigid elements which would tend to prevent a space frame from resisting lateral forces where it can be shown that the action or failure of the more rigid elements will not impair the vertical and lateral load resisting ability of the space frame.
- (b) Exterior Elements : Exterior nonbearing, non-shear wall panels or elements which are attached to or enclose the exterior of a structure, shall be designed to resist the forces according to Sec. 2.5.15 of Chapter 2, if seismic forces are present, and shall accommodate movements of the structure resulting from lateral forces or temperature changes. Such elements shall be supported by structural members or by mechanical connections and fasteners joining them to structural members in accordance with the following provisions:
 - (i) Connections and panel joints shall allow for a relative movement between storeys of not less than two times the storey drift caused by wind forces or design seismic forces, or 12 mm, whichever is greater.
 - (ii) Connections to permit movement in the plane of the panel for storey drift shall be either sliding connections using slotted or oversized holes, connections which permit movement by bending of steel, or other connections providing equivalent sliding and ductility capacity.

- (iii) Bodies of connections shall have sufficient ductility and rotation capability to preclude any fracture of the anchoring elements or brittle failures at or near welding.
- (iv) Bodies of the connection shall be designed for 1.33 times the seismic force determined by Sec. 2.5.15 of Chapter 2, or equivalent.
- (v) All fasteners in the connection system, such as bolts, inserts, welds, dowels etc. shall be designed for 4 times the forces determined by Sec. 2.5.15 of Chapter 2 or equivalent.
- (vi) Fasteners embedded in concrete shall be attached to, or hooked around reinforcing steel, or otherwise terminated so as to transfer forces to the reinforcing steel effectively.

1.7.3.3 Ties and continuity

All parts of a structure shall be interconnected. These connections shall be capable of transmitting the prescribed lateral force to the lateral force resisting system. Individual members, including those not part of the seismic force-resisting system, shall be provided with adequate strength to resist the shears, axial forces, and moments determined in accordance with this Code. Connections shall develop the strength of the connected members and shall be capable of transmitting the seismic force (F_p) induced by the parts being connected.

1.7.3.4 Collector elements

Collector elements shall be provided which are capable of transferring the lateral forces originating in other portions of the structure to the element providing the resistance to those forces.

1.7.3.5 Concrete frames

When concrete frames are provided by design to be part of the lateral force resisting system, they shall conform to the provisions of Chapter 8 of this Part.

1.7.3.6 Anchorage of concrete and masonry structural walls

The concrete and masonry structural walls shall be anchored to supporting construction. The anchorage shall provide a positive direct connection between the wall and floor or roof and shall be capable of resisting the horizontal forces specified in Sections 2.4.11 and 2.5.15, or a minimum force of 4.09 kN/m of wall. Walls shall be designed to resist bending between anchors where the anchor spacing exceeds 1.2 m. In masonry walls of hollow units or cavity walls, anchors shall be embedded in a reinforced grouted structural element of the wall. Deformations of the floor and roof diaphragms shall be considered in the design of the supported walls and the anchorage forces in the diaphragms shall be determined in accordance with Sec 1.7.3.9 below.

1.7.3.7 Boundary members

Specially detailed boundary members shall be considered for shear walls and shear wall elements whenever their design is governed by flexure.

1.7.3.8 Floor and roof diaphragms

Deflection in the plane of the diaphragm shall not exceed the permissible deflection of the attached elements. Permissible deflection shall be that deflection which will permit the attached element to maintain its structural integrity under the individual loading and continue to support the prescribed loads. Design of diaphragms shall also comply with the following requirements.

- (a) Diaphragm Forces: Diaphragms shall be designed to resist the seismic forces given in Sec 2.5 or for similar non-seismic lateral forces, whichever is greater.
- (b) Diaphragm Ties: Diaphragms supporting concrete or masonry walls shall have continuous ties, or struts between the diaphragm chords to distribute the anchorage forces specified in Sec 1.7.3.6 above. Added chords may be provided to form sub-diaphragms to transmit the anchorage forces to the main cross ties.
- (c) Wood Diaphragms: Where wood diaphragms are used to laterally support concrete or masonry walls, the anchorage shall conform to Sec 1.7.3.6 above. In seismic Zones 2, 3 and 4 the following requirements shall also apply:
 - (i) Anchorage shall not be accomplished by use of toe nails or nails subject to withdrawal, nor shall wood ledgers or framing be used in cross-grain bending or cross-grain tension.
 - (ii) The continuous ties required by paragraph (b) above, shall be in addition to the diaphragm sheathing.
- (d) Structures having irregularities
 - (i) For structures assigned to Seismic Design Category D and having a plan irregularity of Type I, II, III, or IV in Table 6.1.5 or a vertical structural irregularity of Type IV in Table 6.1.4, the design forces determined from Sec 2.5.7 shall be increased 25 percent for connections of diaphragms to vertical elements and to collectors and for connections of collectors to the vertical elements. Collectors and their connections also shall be designed for these increased forces unless they are designed for the load combinations with over strength factor.

- (ii) For structures having a plan irregularity of Type II in Table 6.1.5, diaphragm chords and collectors shall be designed considering independent movement of any projecting wings of the structure. Each of these diaphragm elements shall be designed for the more severe of the following cases:
- Motion of the projecting wings in the same direction.
 - Motion of the projecting wings in opposing directions.

Exception:

This requirement may be deemed to be satisfied if the procedures of Sec 2.5.8 when seismic forces are present, in conjunction with a three dimensional model, have been used to determine the lateral seismic forces for design.

1.7.3.9 Framing below the base

When structural framings continue below the base, the following requirements shall be satisfied.

- (a) **Framing between the Base and the Foundation:** The strength and stiffness of the framing between the base and the foundation shall not be less than that of the superstructure. The special detailing requirements of Sec 8.3 or Sec 10.20, as appropriate for reinforced concrete or steel, shall apply to columns supporting discontinuous lateral force resisting elements and to SMF, IMF, and EBF system elements below the base that are required to transmit forces resulting from lateral loads to foundation.
- (b) **Foundations :** The foundation shall be capable of transmitting the design base shear and the overturning forces from the superstructure into the supporting soil, but the short term dynamic nature of the loads may be taken into account in establishing the soil properties. Sec 1.8 below prescribes the additional requirements for specific types of foundation construction.

1.8 Foundation Design Requirements

1.8.1 General

The design and construction of foundation, foundation components and connection between the foundation and superstructure shall conform to the requirements of this Section and applicable provisions of Chapter 3 and other portions of this Code.

1.8.2 Soil Capacities

The bearing capacity of the soil, or the capacity of the soil-foundation system including footing, pile, pier or caisson and the soil, shall be sufficient to support the structure with all prescribed loads, considering the settlement of the structure. For piles, this refers to pile capacity as determined by pile-soil friction and bearing which may be determined in accordance with the provisions of Chapter 3. For the load combination including earthquake, the soil capacity shall be sufficient to resist loads at acceptable strains considering both the short time loading and the dynamic properties of the soil. The stress and settlement of soil under applied loads shall be determined based on established methods of Soil Mechanics.

1.8.3 Superstructure-to-Foundation Connection

The connection of superstructure elements to the foundation shall be adequate to transmit to the foundation the forces for which the elements are required to be designed.

1.8.4 Foundation-Soil Interface

For regular buildings the base overturning moments for the entire structure or for any one of its lateral force-resisting elements, shall not exceed two-thirds of the dead load resisting moment. The weight of the earth superimposed over footings may be used to calculate the dead load resisting moment.

1.8.5 Special Requirements for Footings, Piles and Caissons in Seismic Zones 2, 3 and 4

1.8.5.1 Piles and caissons

Piles and caissons shall be designed for flexure whenever the top of such members is anticipated to be laterally displaced by earthquake motions. The criteria and detailing requirements of Sec 8.3 for concrete and Sec 10.20 for steel shall apply for a length of such members equal to 120 percent of the flexural length.

1.8.5.2 Footing interconnection

- (a) Footings and pile caps shall be completely interconnected by strut ties or other equivalent means to restrain their lateral movements in any orthogonal direction.
- (b) The strut ties or other equivalent means as specified in (a) above, shall be capable of resisting in tension or compression a force not less than 10% of the larger footing or column load unless it can be demonstrated that equivalent restraint can be provided by frictional and passive soil resistance or by other established means.

1.8.6 Retaining wall design

Retaining walls shall be designed to resist the lateral pressure of the retained material, under drained or undrained conditions and including surcharge, in accordance with established engineering practice. For such walls, the minimum factor of safety against base overturning and sliding due to applied earth pressure shall be 1.5.

1.9 Design and Construction Review

Every building or structure designed shall have its design documents prepared in accordance with the provisions of Sec 1.9.1. The minimum requirements for design review and construction observation shall be those set forth under Sections 1.9.2 and 1.9.3 respectively.

1.9.1 Design Document

The design documents shall be prepared and signed by the Engineer responsible for the structural design of any building or structure intended for construction. The design documents shall include a design report, material specifications and a set of structural drawings, which shall be prepared in compliance with Sections 1.9.2 and 1.9.3 below for submittal to the concerned authority. For the purpose of this provision, the concerned authority shall be either persons from the government approval agency for the construction, or the owner of the building or the structure, or one of his representatives.

1.9.2 Design Report

The design report shall contain the description of the structural design with basic design information as provided below, so that any other structural design engineer will be able to independently verify the design parameters and the member sizes using these basic information. The design report shall include, but not be limited to, the following:

- (a) Mention of this Code including relevant Part, Chapter and Section.
- (b) Name of other referenced standards, and the specific portions, stating chapter, section etc. of these Code and standards including any specialist report used for the structural design.
- (c) Methods used for the calculation of all applied loads along with basic load coefficients and other basic information including any assumption or judgment made under special circumstances.

- (d) A drawing of the complete mathematical model prepared in accordance with Sec 1.2.7.1 to represent the structure and showing on it the values, locations and directions of all applied loads, and location of the lateral load resisting systems such as shear walls, braced frames etc.
- (e) Methods of structural analysis, and results of the analysis such as shear, moment, axial force etc., used for proportioning various structural members and joints including foundation members.
- (f) Methods of structural design including types and strength of the materials of construction used for proportioning the structural members.
- (g) Reference of the soil report or any other documents used in the design of the structure, foundation or components thereof.
- (h) Statement supporting the validity of the above design documents with date and signature of the engineer responsible for the structural design.
- (i) When computer programs are used, to any extent, to aid in the analysis or design of the structure, the following items, in addition to items (a) to (g) above, shall be required to be included in the design report:
 - (i) A sketch of the mathematical model used to represent the structure in the computer generated analysis.
 - (ii) The computer output containing the date of processing, program identification, identification of structures being analysed, all input data, units and final results. The computer input data shall be clearly distinguished from those computed in the program.
 - (iii) A program description containing the information necessary to verify the input data and interpret the results to determine the nature and extent of the analysis and to check whether the computations comply with the provisions of this Code.
 - (iv) The first sheet of each computer run shall be signed by the engineer responsible for the structural design.

1.9.3 Structural Drawings and Material Specifications

The structural drawings shall include, but not be limited to, the following:

- (a) The first sheet shall contain :
 - (i) Identification of the project to which the building or the structure, or portion thereof belongs,
 - (ii) Reference to the design report specified in Sec 1.9.2 above,
 - (iii) Date of completion of design, and
 - (iv) Identification and signature with date of the engineer responsible for the structural design.

-
- (b) The second sheet shall contain detail material specifications showing:
- (i) Specified compressive strength of concrete at stated ages or stages of construction for which each part of structure is designed.
 - (ii) Specified strength or grade of reinforcement
 - (iii) Specified strength of prestressing tendons or wires
 - (iv) Specified strength or grade of steel
 - (v) Specified strengths for bolts, welds etc.
 - (vi) Specified strength of masonry, timber, bamboo, ferrocement
 - (vii) Minimum concrete compressive strength at time of post-tensioning
 - (viii) Stressing sequence for post-tensioning tendons
 - (ix) General notes indicating clear cover, development lengths of reinforcements, or any other design parameter relevant to the member or connection details provided in drawings to be followed, as applicable, and
 - (x) Identification and signature with date of the Engineer responsible for the structural design.
- (c) Drawing sheets, other than the first two, shall include structural details of the elements of the structure clearly showing all sizes, cross-sections and relative locations, connections, reinforcements, laps, stiffeners, welding types, lengths and locations etc. whichever is applicable for a particular construction. Floor levels, column centres and offset etc., shall be dimensioned. Camber of trusses and beams, if required, shall be shown on drawings. For bolt connected members, connection types such as slip, critical, tension or bearing type, shall be indicated on the drawing.
- (d) Drawings shall be prepared to a scale large enough to show the information clearly and the scales shall be marked on the drawing sheets. If any variation from the design specifications provided in sheet two occurs, the drawing sheet shall be provided additionally with the design specifications including material types and strength, clear cover and development lengths of reinforcements, or any other design parameter relevant to the member or connection details provided in that drawing sheet. Each drawing sheet shall also contain the signature with date of the engineer responsible for the structural design.

1.9.4 Design Review

The design documents specified in Sec 1.9.1 shall be available for review when required by the concerned authority. Review shall be accomplished by an independent structural engineer qualified for this task and appointed by the concerned authority. Design review shall be performed through independent calculations, based on the information provided in the design documents prepared and signed by the original structural design engineer, to verify the design parameters including applied loads, methods of analysis and design, and final design dimensions and other details of the structural elements. The reviewing engineer shall also check the sufficiency and appropriateness of the supplied structural drawings for construction.

1.9.5 Construction Observation

Construction observation shall be performed by a responsible person who will be a competent professional appointed by the owner of the building or the structure. Construction observation shall include, but not be limited to, the following:

- (a) Specification of an appropriate testing and inspection schedule prepared and signed with date by the responsible person;
- (b) Review of testing and inspection reports; and
- (c) Regular site visit to verify the general compliance of the construction work with the structural drawings and specifications provided in Sec 1.9.3 above.

PART VI
Chapter 2
Loads on Buildings and Structures

2.1 Introduction

2.1.1 Scope

This Chapter specifies the minimum design forces including dead load, live load, wind and earthquake loads, miscellaneous loads and their various combinations. These loads shall be applicable for the design of buildings and structures in conformance with the general design requirements provided in Chapter 1.

2.1.2 Limitations

Provisions of this Chapter shall generally be applied to majority of buildings and other structures covered in this Code subject to normally expected loading conditions. For those buildings and structures having unusual geometrical shapes, response characteristics or site locations, or for those subject to special loading including tornadoes, special dynamic or hydrodynamic loads etc., site-specific or case-specific data or analysis may be required to determine the design loads on them. In such cases, and all other cases for which loads are not specified in this Chapter, loading information may be obtained from reliable references or specialist advice may be sought. However, such loads shall be applied in compliance with the provisions of other Parts or Sections of this Code.

2.1.3 Terminology

The following definitions apply only to the provisions of this Chapter:

ALLOWABLE STRESS DESIGN METHOD (ASD)	A method for proportioning structural members such that the maximum stresses due to service loads obtained from an elastic analysis does not exceed a specified allowable value. This is also called Working Stress Design Method (WSD).
APPROVED	Acceptable to the authority having jurisdiction.
BASE	The level at which the earthquake motions are considered to be imparted to the structures or the level at which the structure as a dynamic vibrator is supported.
BASE SHEAR	Total design lateral force or shear due to earthquake at the base of a structure.

BASIC WIND SPEED, V	Three-second gust speed at 10 m above the ground in Exposure B (Sec 2.4.6.3) having a return period of 50 years.
BEARING WALL SYSTEM	A structural system without a complete vertical load carrying space frame.
BRACED FRAME	An essentially vertical truss system of the concentric or eccentric type provided to resist lateral forces.
BUILDING, ENCLOSED	A building that does not comply with the requirements for open or partially enclosed buildings.
BUILDING ENVELOPE	Cladding, roofing, exterior walls, glazing, door assemblies, window assemblies, skylight assemblies, and other components enclosing the building.
BUILDING, LOW-RISE	Enclosed or partially enclosed buildings that comply with the following conditions <ol style="list-style-type: none"> 1. Mean roof height h less than or equal to 18.3 m. 2. Mean roof height h does not exceed least horizontal dimension.
BUILDING, OPEN	A building having each wall at least 80 percent open. This condition is expressed for each wall by the equation $A_o \geq 0.8A_g$ where, <p>A_o = total area of openings in a wall that receives positive external pressure (m^2).</p> <p>A_g = the gross area of that wall in which A_o is identified (m^2).</p>
BUILDING, PARTIALLY ENCLOSED	A building that complies with both of the following conditions: <ol style="list-style-type: none"> 1. The total area of openings in a wall that receives positive external pressure exceeds the sum of the areas of openings in the balance of the building envelope (walls and roof) by more than 10 percent. 2. The total area of openings in a wall that receives positive external pressure exceeds $0.37 m^2$ or 1 percent of the area of that wall, whichever is smaller, and the percentage of openings in the balance of the building envelope does not exceed 20 percent.

These conditions are expressed by the following equations:

1. $A_o > 1.10A_{oi}$

2. $A_o > 0.37\text{m}^2$ or $> 0.01A_g$, whichever is smaller, and $A_{oi}/A_{gi} \leq 0.20$

Where, A_o , A_g are as defined for open building

A_{oi} = the sum of the areas of openings in the building envelope (walls and roof) not including A_o , in m^2 .

A_{gi} = the sum of the gross surface areas of the building envelope (walls and roof) not including A_g , in m^2 .

BUILDING, SIMPLE DIAPHRAGM	A building in which both windward and leeward wind loads are transmitted through floor and roof diaphragms to the same vertical MWFRS (e.g., no structural separations).
BUILDING FRAME SYSTEM	An essentially complete space frame which provides support for gravity loads.
BUILDING OR OTHER STRUCTURE, FLEXIBLE	Slender buildings or other structures that have a fundamental natural frequency less than 1 Hz.
BUILDING OR OTHER STRUCTURE, REGULAR SHAPED	A building or other structure having no unusual geometrical irregularity in spatial form.
BUILDING OR OTHER STRUCTURES, RIGID	A building or other structure whose fundamental frequency is greater than or equal to 1 Hz.
CAPACITY CURVE	A plot of the total applied lateral force, V_j , versus the lateral displacement of the control point, δ_j , as determined in a nonlinear static analysis.
COMPONENTS AND CLADDING	Elements of the building envelope that do not qualify as part of the MWFRS.
CONTROL POINT	A point used to index the lateral displacement of the structure in a nonlinear static analysis.
CRITICAL DAMPING	Amount of damping beyond which the free vibration will not be oscillatory.

CYCLONE PRONE REGIONS	Areas vulnerable to cyclones; in Bangladesh these areas include the Sundarbans, southern parts of Barisal and Patuakhali, Hatia, Bhola, eastern parts of Chittagong and Cox's Bazar
DAMPING	The effect of inherent energy dissipation mechanisms in a structure (due to sliding, friction, etc.) that results in reduction of effect of vibration, expressed as a percentage of the critical damping for the structure.
DESIGN ACCELERATION RESPONSE SPECTRUM	Smoothened idealized plot of maximum acceleration of a single degree of freedom structure as a function of structure period for design earthquake ground motion.
DESIGN EARTHQUAKE	The earthquake ground motion considered (for normal design) as two-thirds of the corresponding Maximum Considered Earthquake (MCE).
DESIGN FORCE, F	Equivalent static force to be used in the determination of wind loads for open buildings and other structures.
DESIGN PRESSURE, p	Equivalent static pressure to be used in the determination of wind loads for buildings.
DESIGN STRENGTH	The product of the nominal strength and a resistance factor.
DIAPHRAGM	A horizontal or nearly horizontal system of structures acting to transmit lateral forces to the vertical resisting elements. The term "diaphragm" includes reinforced concrete floor slabs as well as horizontal bracing systems.
DUAL SYSTEM	A combination of a Special or Intermediate Moment Resisting Frame and Shear Walls or Braced Frames designed in accordance with the criteria of Sec 1.3.2.4
DUCTILITY	Capacity of a structure, or its members to undergo large inelastic deformations without significant loss of strength or stiffness.
EAVE HEIGHT, h	The distance from the ground surface adjacent to the building to the roof eave line at a particular wall. If the height of the eave varies along the wall, the average height shall be used.

ECCENTRIC BRACED FRAME (EBF)	A steel braced frame designed in conformance with Sec 10.20.15.
EFFECTIVE WIND AREA, A	The area used to determine GC_p . For component and cladding elements, the effective wind area as mentioned in Sec 2.4.11 is the span length multiplied by an effective width that need not be less than one-third the span length. For cladding fasteners, the effective wind area shall not be greater than the area that is tributary to an individual fastener.
EPICENTRE	The point on the surface of earth vertically above the focus (point of origin) of the earthquake.
ESCARPMENT	Also known as scarp, with respect to topographic effects in Sec 2.4.7, a cliff or steep slope generally separating two levels or gently sloping areas (see Figure 6.2.4).
ESSENTIAL FACILITIES	Buildings and structures which are necessary to remain functional during an emergency or a post disaster period.
FACTORED LOAD	The product of the nominal load and a load factor.
FLEXIBLE DIAPHRAGM	A floor or roof diaphragm shall be considered flexible, for purposes of this provision, when the maximum lateral deformation of the diaphragm is more than two times the average storey drift of the associated storey. This may be determined by comparing the computed midpoint in-plane deflection of the diaphragm under lateral load with the storey drift of adjoining vertical resisting elements under equivalent tributary lateral load.
FLEXIBLE ELEMENT OR SYSTEM	An element or system whose deformation under lateral load is significantly larger than adjoining parts of the system.
FREE ROOF	Roof (monoslope, pitched, or troughed) in an open building with no enclosing walls underneath the roof surface.
GLAZING	Glass or transparent or translucent plastic sheet used in windows, doors, skylights, or curtain walls.

GLAZING, IMPACT RESISTANT	Glazing that has been shown by testing in accordance with ASTM E1886 and ASTM E1996 or other approved test methods to withstand the impact of wind-borne missiles likely to be generated in wind-borne debris regions during design winds.
HILL	With respect to topographic effects in Sec 2.4.7, a land surface characterized by strong relief in any horizontal direction (Figure 6.2.4).
HORIZONTAL BRACING SYSTEM	A horizontal truss system that serves the same function as a floor or roof diaphragm.
IMPACT RESISTANT COVERING	A covering designed to protect glazing, which has been shown by testing in accordance with ASTM E1886 and ASTM E1996 or other approved test methods to withstand the impact of wind-borne debris missiles likely to be generated in wind-borne debris regions during design winds.
IMPORTANCE FACTOR, WIND LOAD	A factor that accounts for the degree of hazard to human life and damage to property.
IMPORTANCE FACTOR, EARTHQUAKE LOAD	It is a factor used to increase the design seismic forces for structures of importance.
INTENSITY OF EARTHQUAKE	It is a measure of the amount of ground shaking at a particular site due to an earthquake
INTERMEDIATE MOMENT FRAME (IMF)	A concrete or steel frame designed in accordance with Sec 8.3.10 or Sec 10.20.10 respectively.
LIMIT STATE	A condition in which a structure or component becomes unfit for service and is judged either to be no longer useful for its intended function (serviceability limit state) or to be unsafe (strength limit state).
LIQUEFACTION	State in saturated cohesionless soil wherein the effective shear strength is reduced to negligible value due to pore water pressure generated by earthquake vibrations, when the pore water pressure approaches the total confining pressure. In this condition, the soil tends to behave like a liquid.

LOAD EFFECTS	Forces, moments, deformations and other effects produced in structural members and components by the applied loads.
LOAD FACTOR	A factor that accounts for unavoidable deviations of the actual load from the nominal value and for uncertainties in the analysis that transforms the load into a load effect.
LOADS	Forces or other actions that arise on structural systems from the weight of all permanent constructions, occupants and their possessions, environmental effects, differential settlement, and restrained dimensional changes. Permanent loads are those loads in which variations in time are rare or of small magnitude. All other loads are variable loads.
MAGNITUDE OF EARTHQUAKE	The magnitude of earthquake is a number, which is a measure of energy released in an earthquake.
MAIN WIND-FORCE RESISTING SYSTEM (MWFRS)	An assemblage of structural elements assigned to provide support and stability for the overall structure. The system generally receives wind loading from more than one surface.
MAXIMUM CONSIDERED EARTHQUAKE (MCE)	The most severe earthquake ground motion considered by this Code.
MEAN ROOF HEIGHT, h	The average of the roof eave height and the height to the highest point on the roof surface, except that, for roof angles of less than or equal to 10° , the mean roof height shall be the roof heave height.
MODAL MASS	Part of the total seismic mass of the structure that is effective in mode k of vibration.
MODAL PARTICIPATION FACTOR	Amount by which mode k contributes to the overall vibration of the structure under horizontal and vertical earthquake ground motions.
MODAL SHAPE COEFFICIENT	When a system is vibrating in a normal mode, at any particular instant of time, the vibration amplitude of mass i expressed as a ratio of the vibration amplitude of one of the masses of the system, is known as modal shape coefficient

MOMENT RESISTING FRAME	A frame in which members and joints are capable of resisting lateral forces primarily by flexure. Moment resisting frames are classified as ordinary moment frames (OMF), intermediate moment frames (IMF) and special moment frames (SMF).
NOMINAL LOADS	The magnitudes of the loads such as dead, live, wind, earthquake etc. specified in Sections 2.2 to 2.6 of this Chapter.
NOMINAL STRENGTH	The capacity of a structure or component to resist the effects of loads, as determined by computations using specified material strengths and dimensions and formulas derived from accepted principles of structural mechanics or by field tests or laboratory tests of scaled models, allowing for modelling effects and differences between laboratory and field conditions.
NUMBER OF STOREYS (n)	Number of storeys of a building is the number of levels above the base. This excludes the basement storeys, where basement walls are connected with ground floor deck or fitted between the building columns. But, it includes the basement storeys, when they are not so connected.
OPENINGS	Apertures or holes in the building envelope that allow air to flow through the building envelope and that are designed as “open” during design winds as defined by these provisions.
ORDINARY MOMENT FRAME (OMF)	A moment resisting frame not meeting special detailing requirements for ductile behaviour.
PERIOD OF BUILDING	Fundamental period (for 1st mode) of vibration of building for lateral motion in direction considered.
P-DELTA EFFECT	It is the secondary effect on shears and moments of frame members due to action of the vertical loads due to the lateral displacement of building resulting from seismic forces.
RATIONAL ANALYSIS	An analysis based on established methods or theories using mathematical formulae and actual or appropriately assumed data.

RECOGNIZED LITERATURE	Published research findings and technical papers that are approved.
RESISTANCE FACTOR	A factor that accounts for unavoidable deviations of the actual strength from the nominal value and the manner and consequences of failure. This is also known as strength reduction factor.
RESPONSE REDUCTION FACTOR	It is the factor by which the actual base shear force that would develop if the structure behaved truly elastic during earthquake, is reduced to obtain design base shear. This reduction is allowed to account for the beneficial effects of inelastic deformation (resulting in energy dissipation) that can occur in a structure during a major earthquake, still ensuring acceptable response of the structure.
RIDGE	With respect to topographic effects in Sec 2.4.7, an elongated crest of a hill characterized by strong relief in two directions (Figure 6.2.4).
SEISMIC DESIGN CATEGORY	A classification assigned to a structure based on its importance factor and the severity of the design earthquake ground motion at the site.
SEISMIC-FORCE-RESISTING SYSTEM	That part of the structural system that has been considered in the design to provide the required resistance to the seismic forces.
SHEAR WALL	A wall designed to resist lateral forces acting in its plane (sometimes referred to as a vertical diaphragm or a structural wall).
SITE CLASS	Site is classified based on soil properties of upper 30 m.
SITE-SPECIFIC DATA	Data obtained either from measurements taken at a site or from substantiated field information required specifically for the structure concerned.
SOFT STOREY	Storey in which the lateral stiffness is less than 70 percent of the stiffness of the storey above or less than 80 percent of the average lateral stiffness of the three storeys above.
SPACE FRAME	A three-dimensional structural system without bearing walls composed of members interconnected so as to function as a complete self-contained unit with or without the aid of horizontal diaphragms or floor bracing systems.

SPECIAL MOMENT FRAME (SMF)	A moment resisting frame specially detailed to provide ductile behaviour complying with the seismic requirements provided in Chapters 8 and 10 for concrete and steel frames respectively.
STOREY	The space between consecutive floor levels. Storey-x is the storey below level-x.
STOREY DRIFT	The horizontal deflection at the top of the story relative to bottom of the storey.
STOREY SHEAR STRENGTH	The total horizontal shear force at a particular storey (level). The usable capacity of an element or a member to resist the load as prescribed in these provisions.
STRENGTH DESIGN METHOD	A method of proportioning structural members using load factors and resistance factors satisfying both the applicable limit state conditions. This is also known as Load Factor Design Method (LFD) or Ultimate Strength Design Method (USD).
TARGET DISPLACEMENT	An estimate of the maximum expected displacement of the control point calculated for the design earthquake ground motion in nonlinear static analysis.
VERTICAL LOAD- CARRYING FRAME	A space frame designed to carry all vertical gravity loads.
WEAK STOREY	Storey in which the lateral strength is less than 80 percent of that of the storey above.
WIND-BORNE DEBRIS REGIONS	Areas within cyclone prone regions located: <ol style="list-style-type: none"> 1. Within 1.6 km of the coastal mean high water line where the basic wind speed is equal to or greater than 180 km/h or 2. In areas where the basic wind speed is equal to or greater than 200 km/h.
WORKING STRESS DESIGN METHOD (WSD)	See ALLOWABLE STRESS DESIGN METHOD.

2.1.4 Symbols and Notation

The following symbols and notation apply only to the provisions of this Chapter:

A	= Effective wind area, in m^2
A_f	= Area of open buildings and other structures either normal to the wind direction or projected on a plane normal to the wind direction, in m^2 .
A_g	= Gross area of that wall in which A_o is identified, in m^2 .
A_{gi}	= Sum of gross surface areas of the building envelope (walls and roof) not including A_g , in m^2
A_o	= Total area of openings in a wall that receives positive external pressure, in m^2 .
A_{oi}	= Sum of the areas of openings in the building envelope (walls and roof) not including A_o , in m^2
A_{og}	= Total area of openings in the building envelope in m^2
A_s	= Gross area of the solid freestanding wall or solid sign, in m^2
A_x	= Torsion amplification factor at level- x .
B	= Horizontal dimension of building measured normal to wind direction, in m.
C_d	= Deflection amplification factor.
C_f	= Force coefficient to be used in determination of wind loads for other structures
C_N	= Net pressure coefficient to be used in determination of wind loads for open buildings
C_p	= External pressure coefficient to be used in determination of wind loads for buildings
C_s	= Normalized acceleration response spectrum.
C_t	= Numerical coefficient to determine building period
D	= Diameter of a circular structure or member in m (as used in Sec 2.4).
D	= Dead loads, or related internal moments and forces, Dead load consists of: a) weight of the member itself, b) weight of all materials of construction incorporated into the building to be permanently supported by the member, including built-in partitions, c) weight of permanent equipment (as used in Sec 2.7).

D'	=	Depth of protruding elements such as ribs and spoilers in m.
E	=	Total load effects of earthquake that include both horizontal and vertical, or related internal moments and forces. The horizontal seismic load effect shall include system overstrength factor, Ω_o , if applicable. For specific definition of the earthquake load effect, E , see Sec 2.5.
E_h	=	Horizontal seismic load effect when the effect of system overstrength factor, Ω_o , is not included.
E_{mh}	=	Horizontal seismic load effect when the effect of system overstrength factor, Ω_o , is included.
E_v	=	Vertical effect of seismic load.
F	=	Design wind force for other structures, in N (as used in Sec 2.4).
F	=	Loads due to weight and pressures of fluids with well-defined densities and controllable maximum heights or related internal moments and forces (as used in Sec 2.7).
F_a	=	Loads due to flood or tidal surge or related internal moments and forces.
F_i, F_n, F_x	=	Design lateral force applied to level- i , $-n$, or $-x$ respectively.
F_c	=	Lateral forces on an element or component or on equipment supports.
G	=	Gust effect factor
G_f	=	Gust effect factor for MWFRSs of flexible buildings and other structures
GC_p	=	Product of external pressure coefficient and gust effect factor to be used in determination of wind loads for buildings
GC_{pf}	=	Product of the equivalent external pressure coefficient and gust-effect factor to be used in determination of wind loads for MWFRS of low-rise buildings
GC_{pi}	=	Product of internal pressure coefficient and gust effect factor to be used in determination of wind loads for buildings
GC_{pn}	=	Combined net pressure coefficient for a parapet
H	=	Height of hill or escarpment in Figure 6.2.4 in m.

H	= Loads due to weight and pressure of soil, water in soil, or other materials, or related internal moments and forces (as used in Sec 2.7)
I	= Importance factor
I_z	= Intensity of turbulence from Eq. 6.2.7
K_1, K_2, K_3	= Multipliers in Figure 6.2.4 to obtain K_{zt}
K_d	= Wind directionality factor in Table 6.2.12
K_h	= Velocity pressure exposure coefficient evaluated at height $z = h$
K_z	= Velocity pressure exposure coefficient evaluated at height z
K_{zt}	= Topographic factor as defined in Sec 2.4.7
L	= Horizontal dimension of a building measured parallel to the wind direction, in m (as used in Sec 2.4)
L	= Live loads due to intended use and occupancy, including loads due to movable objects and movable partitions and loads temporarily supported by the structure during maintenance, or related internal moments and forces, L includes any permissible reduction. If resistance to impact loads is taken into account in design, such effects shall be included with the live load L . (as used in Sec 2.7).
L_h	= Distance upwind of crest of hill or escarpment in Figure 6.2.4 to where the difference in ground elevation is half the height of hill or escarpment, in m.
L_r	= Roof live loads, or related internal moments and forces. (as used in Sec 2.7)
L_r	= Horizontal dimension of return corner for a solid freestanding wall or solid sign from Figure 6.2.20, in m. (as used in Sec 2.4)
L_z	= Integral length scale of turbulence, in m.
<i>Level-i</i>	= Floor level of the structure referred to by the subscript i , e.g., $i = 1$ designates the first level above the base.
<i>Level-n</i>	= Uppermost level in the main portion of the structure.
M_x	= Overturning moment at level- x
N_1	= Reduced frequency from Eq. 6.2.14
N_i	= Standard Penetration Number of soil layer i

P_{net}	= Net design wind pressure from Eq. 6.2.4, in N/m^2
P_{net30}	= Net design wind pressure for Exposure A at $h = 9.1$ m and $I = 1.0$ from Figure 6.2.3, in N/m^2 .
P_p	= Combined net pressure on a parapet from Eq. 6.2.22, in N/m^2 .
P_s	= Net design wind pressure from Eq. 6.2.3, in N/m^2 .
P_{s30}	= Simplified design wind pressure for Exposure A at $h = 9.1$ m and $I = 1.0$ from Figure 6.2.2, in N/m^2 .
P_x	= Total vertical design load at level- x
P_w	= Wind pressure acting on windward face in Figure 6.2.9, in N/m^2 .
Q	= Background response factor from Eq. 6.2.8
R	= Resonant response factor from Eq. 6.2.12
R	= Response reduction factor for structural systems. (as used in Sec 2.5)
R	= Rain load, or related internal moments and forces. (as used in Sec 2.7)
R_B, R_h, R_L	= Values from Eq. 6.2.15
R_i	= Reduction factor from Eq. 6.2.18
R_n	= Value from Eq. 6.2.13
S	= Soil factor.
S_a	= Design Spectral Acceleration (in units of g)
S_{ui}	= Undrained shear strength of cohesive layer i
T	= Fundamental period of vibration of structure, in seconds, of the structure in the direction under consideration. (as used in Sec 2.5)
T	= Self-straining forces and cumulative effect of temperature, creep, shrinkage, differential settlement, and shrinkage-compensating concrete, or combinations thereof, or related internal moments and forces. (as used in Sec 2.7)
T_e	= Effective fundamental period of the structure in the direction under consideration, as determined for nonlinear static analysis
V	= Basic wind speed obtained from Figure 6.2.1 or Table 6.2.8, in m/s . The basic wind speed corresponds to a 3-s gust speed at 10 m above ground in Exposure Category B having an annual probability of occurrence of 0.02.

V	= Total design base shear calculated by equivalent static analysis. (as used in Sec 2.5)
V_i	= Unpartitioned internal volume m^3
\bar{V}_z	= mean hourly wind speed at height z , m/s.
V_1	= Total applied lateral force at the first increment of lateral load in nonlinear static analysis.
V_y	= Effective yield strength determined from a bilinear curve fitted to the capacity curve
V_{rs}	= Total design base shear calculated by response spectrum analysis
V_{th}	= Total design base shear calculated by time history analysis
V_{si}	= Shear wave velocity of soil layer i
V_x	= Design storey shear in storey x
W	= Width of building in Figures 6.2.12, 6.2.14(a) and 6.2.14(b), and width of span in Figures 6.2.13 and 6.2.15 in m.
W	= Total seismic weight of building. (as used in Sec 2.5)
W	= Wind load, or related internal moments and forces. (as used in Sec 2.7)
X	= Distance to center of pressure from windward edge in Figure 6.2.18, in m.
Z	= Seismic zone coefficient.
a	= Width of pressure coefficient zone, in m.
b	= Mean hourly wind speed factor in Eq. 6.2.16 from Table 6.2.10
\hat{b}	= 3-s gust speed factor from Table 6.2.10
c	= Turbulence intensity factor in Eq. 6.2.7 from Table 6.2.10
e_{ai}	= Accidental eccentricity of floor mass at level- i
g	= Acceleration due to gravity.
g_Q	= Peak factor for background response in Equations 6.2.6 and 6.2.10
g_R	= Peak factor for resonant response in Eq. 6.2.10
g_V	= Peak factor for wind response in Equations 6.2.6 and 6.2.10

h	= Mean roof height of a building or height of other structure, except that eave height shall be used for roof angle θ of less than or equal to 10° , in m.
h_e	= Roof eave height at a particular wall, or the average height if the eave varies along the wall
h_i, h_n, h_x	= Height in metres above the base to level $i, -n$ or $-x$ respectively
h_{sx}	= Storey Height of storey x (below level- x)
l	= Integral length scale factor from Table 6.2.10 in m.
n_1	= Building natural frequency, Hz
p	= Design pressure to be used in determination of wind loads for buildings, in N/m^2
p_L	= Wind pressure acting on leeward face in Figure 6.2.9, in N/m^2
q	= Velocity pressure, in N/m^2 .
q_h	= Velocity pressure evaluated at height $z = h$, in N/m^2
q_i	= Velocity pressure for internal pressure determination, in N/m^2 .
q_p	= Velocity pressure at top of parapet, in N/m^2 .
q_z	= Velocity pressure evaluated at height z above ground, in N/m^2 .
r	= Rise-to-span ratio for arched roofs.
s	= Vertical dimension of the solid freestanding wall or solid sign from Figure 6.2.20, in m.
w_i, w_x	= Portion of W which is assigned to level i and x respectively
x	= Distance upwind or downwind of crest in Figure 6.2.4, in m.
z	= Height above ground level, in m.
\bar{z}	= Equivalent height of structure, in m.
z_g	= Nominal height of the atmospheric boundary layer used in this standard. Values appear in Table 6.2.10
z_{min}	= Exposure constant from Table 6.2.10
Δ_a	= Maximum allowable storey drift
Δ_x	= Design storey drift of storey x

ϵ	=	Ratio of solid area to gross area for solid freestanding wall, solid sign, open sign, face of a trussed tower, or lattice structure
$\bar{\epsilon}$	=	Integral length scale power law exponent in Eq. 6.2.9 from Table 6.2.10
Ω_o	=	Horizontal seismic overstrength factor from Table 6.2.19
α	=	3-s gust-speed power law exponent from Table 6.2.10
$\hat{\alpha}$	=	Reciprocal of α from Table 6.2.10
$\bar{\alpha}$	=	Mean hourly wind-speed power law exponent in Eq. 6.2.16 from Table 6.2.10
β	=	Damping ratio, percent critical for buildings or other structures
δ_i	=	Horizontal displacement at level- i relative to the base due to applied lateral forces.
δ_j	=	The displacement of the control point at load increment j .
δ_T	=	The target displacement of the control point.
δ_1	=	The displacement of the control point at the first increment of lateral load.
δ_y	=	The effective yield displacement of the control point determined from a bilinear curve fitted to the capacity curve
η	=	Value used in Eq. 6.2.15 (see Sec 2.4.8.2)
η	=	Damping correction factor
θ	=	Angle of plane of roof from horizontal, in degrees. (as used in Sec 2.4)
θ	=	Stability coefficient to assess P-delta effects. (as used in Sec 2.5)
λ	=	Adjustment factor for building height and exposure from Figures 6.2.2 and 6.2.3
ν	=	Height-to-width ratio for solid sign
ξ	=	Viscous damping ratio of the structure
ϕ_{ik}	=	Modal shape coefficient at level i for mode k

2.2 Dead Loads

2.2.1 General

The minimum design dead load for buildings and portions thereof shall be determined in accordance with the provisions of this Section. In addition, design of the overall structure and its primary load-resisting systems shall conform to the general design provisions given in Chapter 1.

2.2.2 Definition

Dead Load is the vertical load due to the weight of permanent structural and non-structural components and attachments of a building such as walls, floors, ceilings, permanent partitions and fixed service equipment etc.

2.2.3 Assessment of Dead Load

Dead load for a structural member shall be assessed based on the forces due to:

- weight of the member itself,
- weight of all materials of construction incorporated into the building to be supported permanently by the member,
- weight of permanent partitions,
- weight of fixed service equipment, and
- net effect of prestressing.

2.2.4 Weight of Materials and Constructions

In estimating dead loads, the actual weights of materials and constructions shall be used, provided that in the absence of definite information, the weights given in Tables 6.2.1 and 6.2.2 shall be assumed for the purposes of design.

Table 6.2.1: Unit Weight of Basic Materials

Material	Unit Weight (kN/m ³)	Material	Unit Weight (kN/m ³)
Aluminium	27.0	Granite, Basalt	26.4
Asphalt	21.2	Iron - cast	70.7
Brass	83.6	- wrought	75.4
Bronze	87.7	Lead	111.0
Brick	18.9	Limestone	24.5
Cement	14.7	Marble	26.4
Coal, loose	8.8	Sand, dry	15.7

Material	Unit Weight (kN/m ³)	Material	Unit Weight (kN/m ³)
Concrete -stone aggregate (unreinforced)	22.8*	Sandstone	22.6
-brick aggregate (unreinforced)	20.4*	Slate	28.3
Copper	86.4	Steel	77.0
Cork, normal	1.7	Stainless Steel	78.75
Cork, compressed	3.7	Timber	5.9-11.0
Glass, window (soda-lime)	25.5	Zinc	70.0

* for reinforced concrete, add 0.63 kN/m³ for each 1% by volume of main reinforcement

Table 6.2.2: Weight of Construction Materials.

Material/Component/Member	Weight per Unit Area (kN/m ²)	Material/Component/Member	Weight per Unit Area (kN/m ²)
Floor		Walls and Partitions	
Asphalt, 25 mm thick	0.526	Acrylic resin sheet, flat, per mm thickness	0.012
Clay tiling, 13 mm thick	0.268	Asbestos cement sheeting:	
Concrete slab (stone aggregate)*:		4.5 mm thick	0.072
solid, 100 mm thick	2.360	6.0 mm thick	0.106
solid, 150 mm thick	3.540	Brick masonry work, excl. plaster:	
Galvanized steel floor deck (excl. topping)	0.147- 0.383	burnt clay, per 100 mm thickness	1.910
Magnesium oxychloride:		sand-lime, per 100 mm thickness	1.980
normal (sawdust filler), 25 mm thick	0.345	Concrete (stone aggregate)*:	
heavy duty (mineral filler), 25 mm thick	0.527	100 mm thick	2.360
Terrazzo paving 16 mm thick	0.431		

Material/Component/Member	Weight per Unit Area (kN/m ²)	Material/Component/Member	Weight per Unit Area (kN/m ²)
Roof		150 mm thick	3.540
Acrylic resin sheet, corrugated:		250 mm thick	5.900
3 mm thick, standard corrugations	0.043	Fibre insulation board, per 10 mm thickness	0.034
3 mm thick, deep corrugations	0.062	Fibrous plaster board, per 10 mm thickness	0.092
Aluminium, corrugated sheeting: (incl. lap and fastenings)		Glass, per 10 mm thickness	0.269
1.2 mm thick	0.048	Hardboard, per 10 mm thickness	0.961
0.8 mm thick	0.028	Particle or flake board, per 10 mm thickness	0.075
0.6 mm thick	0.024	Plaster board, per 10 mm thickness	0.092
Aluminium sheet(plain):		Plywood, per 10 mm thickness	0.061
1.2 mm thick	0.033		
1.0 mm thick	0.024	Ceiling	
0.8 mm thick	0.019	Fibrous plaster, 10 mm thick	0.081
Bituminous felt (5 ply) and gravel	0.431	Cement plaster, 13 mm thick	0.287
Slates:		Suspended metal lath and plaster (two faced incl. studding)	0.480
4.7 mm thick	0.335	Miscellaneous	
9.5 mm thick	0.671	Felt (insulating), per 10 mm thickness	0.019
Steel sheet, flat galvanized:		Plaster:	
1.00 mm thick	0.082	Cement plaster, per 10 mm thickness	0.230
0.80 mm thick	0.067	Lime plaster, per 10 mm thickness	0.191
0.60 mm thick	0.053	PVC sheet, per 10 mm thickness	0.153
Steel, galvanized std. corrugated sheeting: (incl. lap and fastenings)		Rubber paving, per 10 mm thickness	0.151
1.0 mm thick	0.120	Terra-cotta Hollow Block Masonry:	
0.8 mm thick	0.096	75 mm thick	0.671
0.6 mm thick	0.077	100 mm thick	0.995
Tiles :		150 mm thick	1.388
terra-cotta tiles (French pattern)	0.575		
concrete , 25 mm thick	0.527		
clay tiles	0.6-0.9		

* For brick aggregate, 90% of the listed values may be used.

2.2.5 Weight of Permanent Partitions

When partition walls are indicated on the plans, their weight shall be considered as dead load acting as concentrated line loads in their actual positions on the floor. The loads due to anticipated partition walls, which are not indicated on the plans, shall be treated as live loads and determined in accordance with Sec 2.3.6.

2.2.6 Weight of Fixed Service Equipment

Weights of fixed service equipment and other permanent machinery, such as electrical feeders and other machinery, heating, ventilating and air-conditioning systems, lifts and escalators, plumbing stacks and risers etc. shall be included as dead load whenever such equipment are supported by structural members.

2.2.7 Additional Loads

In evaluating the final dead loads on a structural member for design purposes, allowances shall be made for additional loads resulting from the (i) difference between the prescribed and the actual weights of the members and construction materials; (ii) inclusion of future installations; (iii) changes in occupancy or use of buildings; and (iv) inclusion of structural and non-structural members not covered in Sections 2.2.2 and 2.2.3.

2.3 Live Loads

2.3.1 General

The live loads used for the structural design of floors, roof and the supporting members shall be the greatest applied loads arising from the intended use or occupancy of the building, or from the stacking of materials and the use of equipment and propping during construction, but shall not be less than the minimum design live loads set out by the provisions of this Section. For the design of structural members for forces including live loads, requirements of the relevant Sections of Chapter 1 shall also be fulfilled.

2.3.2 Definition

Live load is the load superimposed by the use or occupancy of the building not including the environmental loads such as wind load, rain load, earthquake load or dead load.

2.3.3 Minimum Floor Live Loads

The minimum floor live loads shall be the greatest actual imposed loads resulting from the intended use or occupancy of the floor, and shall not be less than the uniformly distributed load patterns specified in Sec 2.3.4 or the concentrated loads specified in Sec 2.3.5 whichever produces the most critical effect. The live loads shall be assumed to act vertically upon the area projected on a horizontal plane.

2.3.4 Uniformly Distributed Loads

The uniformly distributed live load shall not be less than the values listed in Table 6.2.3, reduced as may be specified in Sec 2.3.13, applied uniformly over the entire area of the floor, or any portion thereof to produce the most adverse effects in the member concerned.

2.3.5 Concentrated Loads

The concentrated load to be applied non-concurrently with the uniformly distributed load given in Sec 2.3.4, shall not be less than that listed in Table 6.2.3. Unless otherwise specified in Table 6.2.3 or in the following paragraph, the concentrated load shall be applied over an area of 300 mm × 300 mm and shall be located so as to produce the maximum stress conditions in the structural members.

In areas where vehicles are used or stored, such as car parking garages, ramps, repair shops etc., provision shall be made for concentrated loads consisting of two or more loads spaced nominally 1.5 m on centres in absence of the uniform live loads. Each load shall be 40 percent of the gross weight of the maximum size vehicle to be accommodated and applied over an area of 750 mm × 750 mm. For the storage of private or pleasure-type vehicles without repair or fuelling, floors shall be investigated in the absence of the uniform live load, for a minimum concentrated wheel load of 9 kN spaced 1.5 m on centres, applied over an area of 750 mm × 750 mm. The uniform live loads for these cases are provided in Table 6.2.3. The condition of concentrated or uniform live load producing the greater stresses shall govern.

Table 6.2.3: Minimum Uniformly Distributed and Concentrated Live Loads^a

Occupancy or Use	Uniform kN/m ²	Concentrated kN
Apartments (see Residential)		
Access floor systems		
Office use	2.40	9.0
Computer use	4.80	9.0
Armories and drill rooms	7.20	--

Occupancy or Use	Uniform kN/m ²	Concentrated kN
Assembly areas and theaters		
Fixed seats (fastened to floor)	2.90	--
Lobbies	4.80	--
Movable seats	4.80	--
Platforms (assembly)	4.80	--
Stage floors	7.20	--
Balconies (exterior)	4.80	--
On one- and two-family residences only, and not exceeding 19.3 m ²	2.90	--
Bowling alleys, poolrooms, and similar recreational areas	3.60	--
Catwalks for maintenance access	2.00	1.33
Corridors		
First floor	4.80	--
Other floors, same as occupancy served except as indicated		
Dance halls and ballrooms	4.80	--
Decks (patio and roof)	Same as area served, or for the type of occupancy accommodated	
Dining rooms and restaurants	4.80	--
Dwellings (see <i>Residential</i>)	--	
Elevator machine room grating (on area of 2,580 mm ²)	--	1.33
Finish light floor plate construction (on area of 645 mm ²)	--	0.90
Fire escapes	4.80	--
On single-family dwellings only	2.00	--
Fixed ladders	See Sec 2.3.11	
Garages (passenger vehicles only), Trucks and buses	2.0 ^{b,c}	
Grandstands	See <i>Stadiums and arenas, Bleachers</i>	
Gymnasiums—main floors and balconies	4.80	--
Handrails, guardrails, and grab bars	See Sec 2.3.11	
Hospitals		
Operating rooms, laboratories	2.90	4.50
Patient rooms	2.00	4.50
Corridors above first floor	3.80	4.50

Occupancy or Use	Uniform kN/m ²	Concentrated kN
Hotels	<i>See Residential</i>	
Libraries		
Reading rooms	2.90	4.50
Stack rooms	7.20 ^d	4.50
Corridors above first floor	3.80	4.50
Manufacturing*		
Light	4.00	6.00
Medium	6.00	9.00
Heavy	12.00	13.40
Garments manufacturing floor except stacking or storage area	4.00 ^e	--
Stacking or storage area of garments manufacturing industry	6.00 ^f	10.00 ^f
Marquees	3.60	--
Office Buildings		
File and computer rooms shall be designed for heavier loads based on anticipated occupancy		
Lobbies and first-floor corridors	4.80	9.00
Offices	2.40	9.00
Corridors above first floor	3.80	9.00
Penal Institutions		
Cell blocks	2.00	--
Corridors	4.80	--
Residential		
Dwellings (one- and two-family)		
Uninhabitable attics without storage	0.50	--
Uninhabitable attics with storage	1.00	--
Habitable attics and sleeping areas	1.50	--
All other areas except stairs and balconies	2.00	--
Hotels and multifamily houses		
Private rooms and corridors serving them	2.00	--
Public rooms and corridors serving them	4.80	--
Reviewing stands, grandstands, and bleachers	4.80 ^g	--

Occupancy or Use	Uniform kN/m ²	Concentrated kN
Roofs		
Ordinary flat roof	1.00 ^h	--
Pitched and curved roofs	See Table 6.2.4	
Roofs used for promenade purposes	2.90	--
Roofs used for roof gardens or assembly purposes	4.80	--
Roofs used for other special purposes	See Note ⁱ below	
Awnings and canopies		
Fabric construction supported by a lightweight rigid skeleton structure	0.24 (nonreducible)	--
All other construction	1.00	--
Primary roof members exposed to a work floor		
Single panel point of lower chord of roof trusses or any point along primary structural members supporting roofs over manufacturing, storage warehouses, and repair garages	--	9.00
All other occupancies	--	1.33
All roof surfaces subject to maintenance workers	--	1.33
Schools		
Classrooms	2.00	4.50
Corridors above first floor	3.80	4.50
First-floor corridors	4.80	4.50
Scuttles, skylight ribs, and accessible ceilings		0.90
Sidewalks, vehicular driveways, and yards subject to trucking	12.00 ^j	35.60 ^k
Stadiums and arenas		
Bleachers	4.80 ^g	--
Fixed seats (fastened to floor)	2.90 ^g	--
Stairs and exit ways	4.80	See Note ^l
One- and two-family residences only	2.00	below --

Occupancy or Use	Uniform kN/m ²	Concentrated kN
Storage areas above ceilings	1.00	--
Storage warehouses (shall be designed for heavier loads if required for anticipated storage)		
Light	6.00	--
Heavy	12.00	--
Stores		
Retail		
First floor	4.80	4.50
Upper floors	3.60	4.50
Wholesale, all floors	6.00	4.50
Vehicle barriers	See Sec 2.3.11	
Walkways and elevated platforms (other than exit ways)	2.90	--
Yards and terraces, pedestrian	4.80	--

Notes:

- a* It must be ensured that the average weight of equipment, machinery, raw materials and products that may occupy the floor is less than the specified value in the Table. In case the weight exceeds the specified values in the Table, actual maximum probable weight acting in the actual manner shall be used in the analysis and design.
- b* Floors in garages or portions of a building used for the storage of motor vehicles shall be designed for the uniformly distributed live loads of Table 6.2.3 or the following concentrated load: (1) for garages restricted to passenger vehicles accommodating not more than nine passengers, 13.35 kN acting on an area of 114 mm by 114 mm footprint of a jack; and (2) for mechanical parking structures without slab or deck that are used for storing passenger car only, 10 kN per wheel.
- c* Garages accommodating trucks and buses shall be designed in accordance with an approved method, which contains provisions for truck and bus loadings.
- d* The loading applies to stack room floors that support non-mobile, double-faced library book stacks subject to the following limitations: (1) The nominal book stack unit height shall not exceed 2290 mm; (2) the nominal shelf depth shall not exceed 300 mm for each face; (3) parallel rows of double-faced book stacks shall be separated by aisles not less than 900 mm wide.

-
- e* Subject to the provisions of reduction of live load as per Sec 2.3.13
- f* Uniformly distributed and concentrated load provisions are applicable for a maximum floor height of 3.5 m. In case of higher floor height, the load(s) must be proportionally increased.
- g* In addition to the vertical live loads, the design shall include horizontal swaying forces applied to each row of the seats as follows: 0.350 kN per linear meter of seat applied in a direction parallel to each row of seats and 0.15 kN per linear meter of seat applied in a direction perpendicular to each row of seats. The parallel and perpendicular horizontal swaying forces need not be applied simultaneously.
- h* Where uniform roof live loads are reduced to less than 1.0 kN/m² in accordance with Sec 2.3.14.1 and are applied to the design of structural members arranged so as to create continuity, the reduced roof live load shall be applied to adjacent spans or to alternate spans, whichever produces the greatest unfavorable effect.
- i* Roofs used for other special purposes shall be designed for appropriate loads as approved by the authority having jurisdiction.
- j* Other uniform loads in accordance with an approved method, which contains provisions for truck loadings, shall also be considered where appropriate.
- k* The concentrated wheel load shall be applied on an area of 114 mm by 114 mm footprint of a jack.
- l* Minimum concentrated load on stair treads (on area of 2,580 mm²) is 1.33 kN.
- * The loading in industrial buildings varies considerably and so the loadings under the terms 'light,' 'medium' and 'heavy' are introduced in order to allow for which the relevant floor is designed. It is however important to assess the actual loads to ensure that they are not in excess of the stipulated load, in case where they are in excess, the design shall be based on the actual loadings.
-

2.3.6 Provision for Partition Walls

When partitions, not indicated on the plans, are anticipated to be placed on the floors, their weight shall be included as an additional live load acting as concentrated line loads in an arrangement producing the most severe effect on the floor, unless it can be shown that a more favourable arrangement of the partitions shall prevail during the future use of the floor.

In the case of light partitions, wherein the total weight per metre run is not greater than 5.5 kN, a uniformly distributed live load may be applied on the floor in lieu of the concentrated line loads specified above. Such uniform live load per square metre shall be at least 33% of the weight per metre run of the partitions, subject to a minimum of 1.2 kN/m².

2.3.7 More than One Occupancy

Where an area of a floor is intended for two or more occupancies at different times, the value to be used from Table 6.2.3 shall be the greatest value for any of the occupancies concerned.

2.3.8 Minimum Roof Live Loads

Roof live loads shall be assumed to act vertically over the area projected by the roof or any portion of it upon a horizontal plane, and shall be determined as specified in Table 6.2.4.

Table 6.2.4: Minimum Roof Live Loads⁽¹⁾

Type and Slope of Roof		Distributed Load, kN/m ²	Concentrated Load, kN
I	Flat roof (slope = 0)	See Table 6.2.3	
II	(A) Pitched or sloped roof ($0 < \text{slope} < 1/3$) (B) Arched roof or dome (rise $< 1/8$ span)	1.0	0.9
III	(A) Pitched or sloped roof ($1/3 \leq \text{slope} < 1.0$) (B) Arched roof or dome ($1/8 \leq \text{rise} < 3/8$ span)	0.8	0.9
IV	(A) Pitched or sloped roof (slope ≥ 1.0) (B) Arched roof or dome (rise $\geq 3/8$ span)	0.6	0.9
V	Greenhouse, and agriculture buildings	0.5	0.9
VI	Canopies and awnings, except those with cloth covers	Same as given in I to IV above based on the type and slope.	

Note: ⁽¹⁾ Greater of this load and rain load as specified in Sec 2.6.2 shall be taken as the design live load for roof. The distributed load shall be applied over the area of the roof projected upon a horizontal plane and shall not be applied simultaneously with the concentrated load. The concentrated load shall be assumed to act upon a 300 mm × 300 mm area and need not be considered for roofs capable of laterally distributing the load, e.g. reinforced concrete slabs.

2.3.9 Loads not Specified

Live loads, not specified for uses or occupancies in Sections 2.3.3, 2.3.4 and 2.3.5, shall be determined from loads resulting from:

- weight of the probable assembly of persons;
- weight of the probable accumulation of equipment and furniture, and
- weight of the probable storage of materials.

2.3.10 Partial Loading and Other Loading Arrangements

The full intensity of the appropriately reduced live load applied only to a portion of the length or area of a structure or member shall be considered, if it produces a more unfavourable effect than the same intensity applied over the full length or area of the structure or member.

Where uniformly distributed live loads are used in the design of continuous members and their supports, consideration shall be given to full dead load on all spans in combination with full live loads on adjacent spans and on alternate spans whichever produces a more unfavourable effect.

2.3.11 Other Live Loads

Live loads on miscellaneous structures and components, such as handrails and supporting members, parapets and balustrades, ceilings, skylights and supports, and the like, shall be determined from the analysis of the actual loads on them, but shall not be less than those given in Table 6.2.5.

2.3.12 Impact and Dynamic Loads

The live loads specified in Sec 2.3.3 shall be assumed to include allowances for impacts arising from normal uses only. However, forces imposed by unusual vibrations and impacts resulting from the operation of installed machinery and equipment shall be determined separately and treated as additional live loads. Live loads due to vibration or impact shall be determined by dynamic analysis of the supporting member or structure including foundations, or from the recommended values supplied by the manufacture of the particular equipment or machinery. In absence of definite information, values listed in Table 6.2.6 for some common equipment, shall be used for design purposes.

Table 6.2.5: Miscellaneous Live Loads

Structural Member or Component	Live Load ⁽¹⁾ (kN/m)
A. Handrails, parapets and supports:	
(a) Light access stairs, gangways etc.	
(i) width ≤ 0.6 m	0.25
(ii) width > 0.6 m	0.35
(b) Staircases other than in (a) above, ramps, balconies:	
(i) Single dwelling and private	0.35
(ii) Staircases in residential buildings	0.35
(iii) Balconies or portion thereof, stands etc. having fixed seats within 0.55 m of the barrier	1.5
(iv) Public assembly buildings including theatres, cinemas, assembly halls, stadiums, mosques, churches, schools etc.	3.0
(v) Buildings and occupancies other than (i) to (iv) above	0.75

B. Vehicle barriers for car parks and ramps:

(a) For vehicles having gross mass ≤ 2500 kg	100 ⁽²⁾
(b) For vehicles having gross mass > 2500 kg	165 ⁽²⁾
(c) For ramps of car parks etc.	see note ⁽³⁾

Notes: (1) These loads shall be applied non-concurrently along horizontal and vertical directions, except as specified in note (2) below.

(2) These loads shall be applied only in the horizontal direction, uniformly distributed over any length of 1.5 m of a barrier and shall be considered to act at bumper height. For case 2(a) bumper height may be taken as 375 mm above floor level.

(3) Barriers to access ramps of car parks shall be designed for horizontal forces equal to 50% of those given in 2(a) and 2(b) applied at a level of 610 mm above the ramp. Barriers to straight exit ramps exceeding 20 m in length shall be designed for horizontal forces equal to twice the values given in 2(a) and 2(b).

Table 6.2.6: Minimum Live Loads on Supports and Connections of Equipment due to Impact⁽¹⁾

Equipment or Machinery	Additional load due to impact as percentage of static load including self-weight	
	Vertical	Horizontal
1. Lifts, hoists and related operating machinery	100%	Not applicable
2. Light machinery (shaft or motor driven)	20%	Not applicable
3. Reciprocating machinery, or power driven units.	50%	Not applicable
4. Hangers supporting floors and balconies	33%	Not applicable
5. Cranes :		(i) Transverse to the rail :
(a) Electric overhead cranes	25% of maximum wheel load	20% of the weight of trolley and lifted load only, applied one-half at the top of each rail
		(ii) Along the rail :
		10% of maximum wheel load applied at the top of each rail

Equipment or Machinery	Additional load due to impact as percentage of static load including self-weight	
	Vertical	Horizontal
(b) Manually operated cranes	50% of the values in (a) above	50% of the values in (a) above
(c) Cab-operated travelling cranes	25%	Not applicable

⁽¹⁾ All these loads shall be increased if so recommended by the manufacturer. For machinery and equipment not listed, impact loads shall be those recommended by the manufacturers, or determined by dynamic analysis.

2.3.13 Reduction of Live Loads

Except for roof uniform live loads, all other minimum uniformly distributed live loads, L_o in Table 6.2.3, may be reduced according to the following provisions.

2.3.13.1 General

Subject to the limitations of Sections 2.3.13.2 to 2.3.13.5, members for which a value of $K_{LL}A_T$ is 37.16 m² or more are permitted to be designed for a reduced live load in accordance with the following formula:

$$L = L_o \left(0.25 + \frac{4.57}{\sqrt{K_{LL}A_T}} \right) \quad (6.2.1)$$

Where, L = reduced design live load per m² of area supported by the member; L_o = unreduced design live load per m² of area supported by the member (Table 6.2.3); K_{LL} = live load element factor (Table 6.2.7); A_T = tributary area in m², L shall not be less than $0.50L_o$ for members supporting one floor and L shall not be less than $0.40L_o$ for members supporting two or more floors.

Table 6.2.7: Live Load Element Factor, K_{LL}

Element	K_{LL} *
Interior columns	4
Exterior columns without cantilever slabs	4
Edge columns with cantilever slabs	3
Corner columns with cantilever slabs	2
Edge beams without cantilever slabs	2
Interior beams	2

All other members not identified including:	1
<ul style="list-style-type: none"> • Edge beams with cantilever slabs • Cantilever beams • One-way slabs • Two-way slabs • Members without provisions for continuous shear transfer normal to their span 	

*In lieu of the preceding values, K_{LL} is permitted to be calculated.

2.3.13.2 Heavy live loads

Live loads that exceed 4.80 kN/m^2 shall not be reduced.

Exception: Live loads for members supporting two or more floors may be reduced by 20 percent.

2.3.13.3 Passenger car garages

The live loads shall not be reduced in passenger car garages.

Exception: Live loads for members supporting two or more floors may be reduced by 20 percent.

2.3.13.4 Special occupancies

(a) Live loads of 4.80 kN/m^2 or less shall not be reduced in public assembly occupancies.

(b) There shall be no reduction of live loads for cyclone shelters.

2.3.13.5 Limitations on one-way slabs

The tributary area, A_T , for one-way slabs shall not exceed an area defined by the slab span times a width normal to the span of 1.5 times the slab span.

2.3.14 Reduction in Roof Live Loads

The minimum uniformly distributed roof live loads, L_o in Table 6.2.3, are permitted to be reduced according to the following provisions.

2.3.14.1 Flat, pitched, and curved roofs.

Ordinary flat, pitched, and curved roofs are permitted to be designed for a reduced roof live load, as specified in Eq. 6.2.2 or other controlling combinations of loads, as discussed later in this Chapter, whichever produces the greater load. In structures

such as greenhouses, where special scaffolding is used as a work surface for workmen and materials during maintenance and repair operations, a lower roof load than specified in Eq. 6.2.2 shall not be used unless approved by the authority having jurisdiction. On such structures, the minimum roof live load shall be 0.60 kN/m^2 .

$$L_r = L_o R_1 R_2 \quad (0.60 \leq L_r \leq 1.00) \quad (6.2.2)$$

Where,

L_r = reduced roof live load per m^2 of horizontal projection in kN/m^2

The reduction factors R_1 and R_2 shall be determined as follows:

$$R_1 = 1 \text{ for } A_t \leq 18.58 \text{ m}^2$$

$$= 1.2 - 0.011A_t \text{ for } 18.58 \text{ m}^2 < A_t < 55.74 \text{ m}^2$$

$$= 0.6 \text{ for } A_t \geq 55.74 \text{ m}^2$$

A_t = tributary area in m^2 supported by any structural member and

$$R_2 = 1 \text{ for } F \leq 4$$

$$= 1.2 - 0.05F \text{ for } 4 < F < 12$$

$$= 0.6 \text{ for } F \geq 12$$

For a pitched roof, $F = 0.12 \times \text{slope}$, with slope expressed in percentage points and, for an arch or dome, $F = \text{rise-to-span ratio multiplied by } 32$.

2.3.14.2 Special purpose roofs.

Roofs that have an occupancy function, such as roof gardens, assembly purposes, or other special purposes are permitted to have their uniformly distributed live load reduced in accordance with the requirements of Sec 2.3.13.

2.4 Wind Loads

2.4.1 General

Scope: Buildings and other structures, including the Main Wind-Force Resisting System (MWFRS) and all components and cladding thereof, shall be designed and constructed to resist wind loads as specified herein.

Allowed Procedures: The design wind loads for buildings and other structures, including the MWFRS and component and cladding elements thereof, shall be determined using one of the following procedures:

- Method 1: Simplified Procedure as specified in Sec 2.4.2 for buildings and structures meeting the requirements specified therein;
- Method 2: Analytical Procedure as specified in Sec 2.4.3 for buildings and structures meeting the requirements specified therein;
- Method 3: Wind Tunnel Procedure as specified in Sec 2.4.16.

Wind Pressures Acting on opposite faces of each building surface. In the calculation of design wind loads for the MWFRS and for components and cladding for buildings, the algebraic sum of the pressures acting on opposite faces of each building surface shall be taken into account.

Minimum Design Wind Loading

The design wind load, determined by any one of the procedures specified in Sec 2.4.1, shall be not less than specified in this Section.

Main Wind-Force Resisting System: The wind load to be used in the design of the MWFRS for an enclosed or partially enclosed building or other structure shall not be less than 0.5 kN/m^2 multiplied by the area of the building or structure projected onto a vertical plane normal to the assumed wind direction. The design wind force for open buildings and other structures shall be not less than 0.5 kN/m^2 multiplied by the area A_f .

Components and Cladding: The design wind pressure for components and cladding of buildings shall not be less than a net pressure of 0.5 kN/m^2 acting in either direction normal to the surface.

2.4.2 Method 1: Simplified Procedure

2.4.2.1 Scope

A building whose design wind loads are determined in accordance with this Section shall meet all the conditions of Sec 2.4.2.2 or Sec 2.4.2.3. If a building qualifies only under Sec 2.4.2.3 for design of its components and cladding, then its MWFRS shall be designed by Method 2 or Method 3.

Limitations on Wind Speeds: Variation of basic wind speeds with direction shall not be permitted unless substantiated by any established analytical method or wind tunnel testing.

2.4.2.2 Main wind-force resisting systems

For the design of MWFRSs the building must meet all of the following conditions:

- (1) The building is a simple diaphragm building as defined in Sec 2.1.3.
- (2) The building is a low-rise building as defined in Sec 2.1.3.
- (3) The building is enclosed as defined in Sec 2.1.3 and conforms to the wind-borne debris provisions of Sec 2.4.9.3.
- (4) The building is a regular-shaped building or structure as defined in Sec 2.1.3.
- (5) The building is not classified as a flexible building as defined in Sec 2.1.3.

- (6) The building does not have response characteristics making it subject to a cross wind loading, vortex shedding, instability due to galloping or flutter; and does not have a site location for which channeling effects or buffeting in the wake of upwind obstructions warrant special consideration.
- (7) The building has an approximately symmetrical cross-section in each direction with either a flat roof or a gable or hip roof with $\theta \leq 45^\circ$.
- (8) The building is exempted from torsional load cases as indicated in Note 5 of Figure 6.2.10, or the torsional load cases defined in Note 5 do not control the design of any of the MWFRSs of the building.

2.4.2.3 Components and cladding

For the design of components and cladding the building must meet all the following conditions:

- (1) The mean roof height h must be less than or equal to 18.3 m ($h \leq 18.3$ m).
- (2) The building is enclosed as defined in Sec 2.1.3 and conforms to wind-borne debris provisions of Sec 2.4.9.3.
- (3) The building is a regular-shaped building or structure as defined in Sec 2.1.3.
- (4) The building does not have response characteristics making it subject to across-wind loading, vortex shedding, instability due to galloping or flutter; and does not have a site location for which channeling effects or buffeting in the wake of upwind obstructions warrant special consideration.
- (5) The building has either a flat roof, a gable roof with $\theta \leq 45^\circ$, or a hip roof with $\theta \leq 27^\circ$.

2.4.2.4 Design procedure

- (1) The basic wind speed V shall be determined in accordance with Sec 2.4.4. The wind shall be assumed to come from any horizontal direction.
- (2) An importance factor I shall be determined in accordance with Sec 2.4.5.
- (3) An exposure category shall be determined in accordance with Sec 2.4.6.3.
- (4) A height and exposure adjustment coefficient, λ shall be determined from Figure 6.2.2.

2.4.2.4.1 Main wind-force resisting system: Simplified design wind pressures, p_s , for the MWFRSs of low-rise simple diaphragm buildings represent the net pressures (sum of internal and external) to be applied to the horizontal and vertical projections of building surfaces as shown in Figure 6.2.2. For the horizontal pressures (zones A, B, C, D), p_s is the combination of the windward and leeward net pressures. p_s shall be determined by the following equation:

$$p_s = \lambda K_{zt} I p_{s30} \quad (6.2.3)$$

Where,

λ = adjustment factor for building height and exposure from Figure 6.2.2

K_{zt} = topographic factor as defined in Sec 2.4.7 evaluated at mean roof height, h

I = importance factor as defined in Sec 2.4.5

p_{s30} = simplified design wind pressure for Exposure A, at $h = 9.1$ m, and for $I = 1.0$, refer to Figure 6-2 of ASCE 7-05.

Minimum Pressures: The load effects of the design wind pressures from this Section shall not be less than the minimum load case from Sec 2.4.2.1 assuming the pressures, p_s , for zones A, B, C, and D all equal to $+ 0.5$ kN/m², while assuming zones E, F, G, and H all equal to zero kN/m².

2.4.2.4.2 Components and cladding: Net design wind pressures, p_{net} , for the components and cladding of buildings designed using Method 1 represent the net pressures (sum of internal and external) to be applied normal to each building surface as shown in Figure 6.2.3. p_{net} shall be determined by the following equation:

$$p_{net} = \lambda K_{zt} I p_{net30} \quad (6.2.4)$$

Where,

λ = adjustment factor for building height and exposure from Figure 6.2.3

K_{zt} = topographic factor as defined in Sec 2.4.7 evaluated at mean roof height, h

I = importance factor as defined in Sec 2.4.5

p_{net30} = net design wind pressure for Exposure A, at $h = 9.1$ m, and for $I = 1.0$, refer to Figure 6-3 of ASCE 7-05.

Minimum Pressures: The positive design wind pressures, p_{net} , from this Section shall not be less than $+0.5 \text{ kN/m}^2$, and the negative design wind pressures, p_{net} , from this Section shall not be less than -0.5 kN/m^2 .

2.4.2.4.3 Air permeable cladding

Design wind loads determined from Figure 6.2.3 shall be used for all air permeable cladding unless approved test data or the recognized literature demonstrate lower loads for the type of air permeable cladding being considered.

2.4.3 Method 2: Analytical Procedure

2.4.3.1 Scopes and limitations

A building or other structure whose design wind loads are determined in accordance with this Section shall meet all of the following conditions:

- (1) The building or other structure is a regular-shaped building or structure as defined in Sec 2.1.3.
- (2) The building or other structure does not have response characteristics making it subject to across-wind loading, vortex shedding, instability due to galloping or flutter; or does not have a site location for which channeling effects or buffeting in the wake of upwind obstructions warrant special consideration.

The provisions of this Section take into consideration of the load magnification effect caused by gusts in resonance with along-wind vibrations of flexible buildings or other structures. Buildings or other structures not meeting the requirements of Sec 2.4.2, or having unusual shapes or response characteristics shall be designed using recognized literature documenting such wind load effects or shall use the wind tunnel procedure specified in Sec 2.4.16.

2.4.3.2 Shielding

There shall be no reductions in velocity pressure due to apparent shielding afforded by buildings and other structures or terrain features.

2.4.3.3 Air permeable cladding

Design wind loads determined from Sec 2.4.3 shall be used for air permeable cladding unless approved test data or recognized literature demonstrate lower loads for the type of air permeable cladding being considered.

2.4.3.4 Design procedure

- (1) The basic wind speed V and wind directionality factor K_d shall be determined in accordance with Sec 2.4.4.
- (2) An importance factor I shall be determined in accordance with Sec 2.4.5.
- (3) An exposure category or exposure categories and velocity pressure exposure coefficient K_z or K_h , as applicable, shall be determined for each wind direction in accordance with Sec 2.4.6.
- (4) A topographic factor K_{zt} shall be determined in accordance with Sec 2.4.7.
- (5) A gust effect factor G or G_f , as applicable, shall be determined in accordance with Sec 2.4.8.
- (6) An enclosure classification shall be determined in accordance with Sec 2.4.9.
- (7) Internal pressure coefficient GC_{pi} shall be determined in accordance with Sec 2.4.10.1.
- (8) External pressure coefficients C_p or GC_{pf} , or force coefficients C_f , as applicable, shall be determined in accordance with Sections 2.4.10.2 or 2.4.10.3, respectively.
- (9) Velocity pressure q_z or q_h , as applicable, shall be determined in accordance with Sec 2.4.9.5.
- (10) Design wind load P or F shall be determined in accordance with Sec 2.4.11.

2.4.4 Basic Wind Speed

The basic wind speed, V used in the determination of design wind loads on buildings and other structures shall be as given in Figure 6.2.1 except as provided in Sec 2.4.4.1. The wind shall be assumed to come from any horizontal direction.

2.4.4.1 Special wind regions

The basic wind speed shall be increased where records or experience indicate that the wind speeds are higher than those reflected in Figure 6.2.1. Mountainous terrain, gorges, and special regions shall be examined for unusual wind conditions. The authority having jurisdiction shall, if necessary, adjust the values given in Figure 6.2.1 to account for higher local wind speeds. Such adjustment shall be based on adequate meteorological information and other necessary data.

2.4.4.2 Limitation

Tornadoes have not been considered in developing the basic wind-speed distributions.

2.4.4.3 Wind directionality factor

The wind directionality factor, K_d shall be determined from Table 6.2.12. This factor shall only be applied when used in conjunction with load combinations specified in this Chapter.

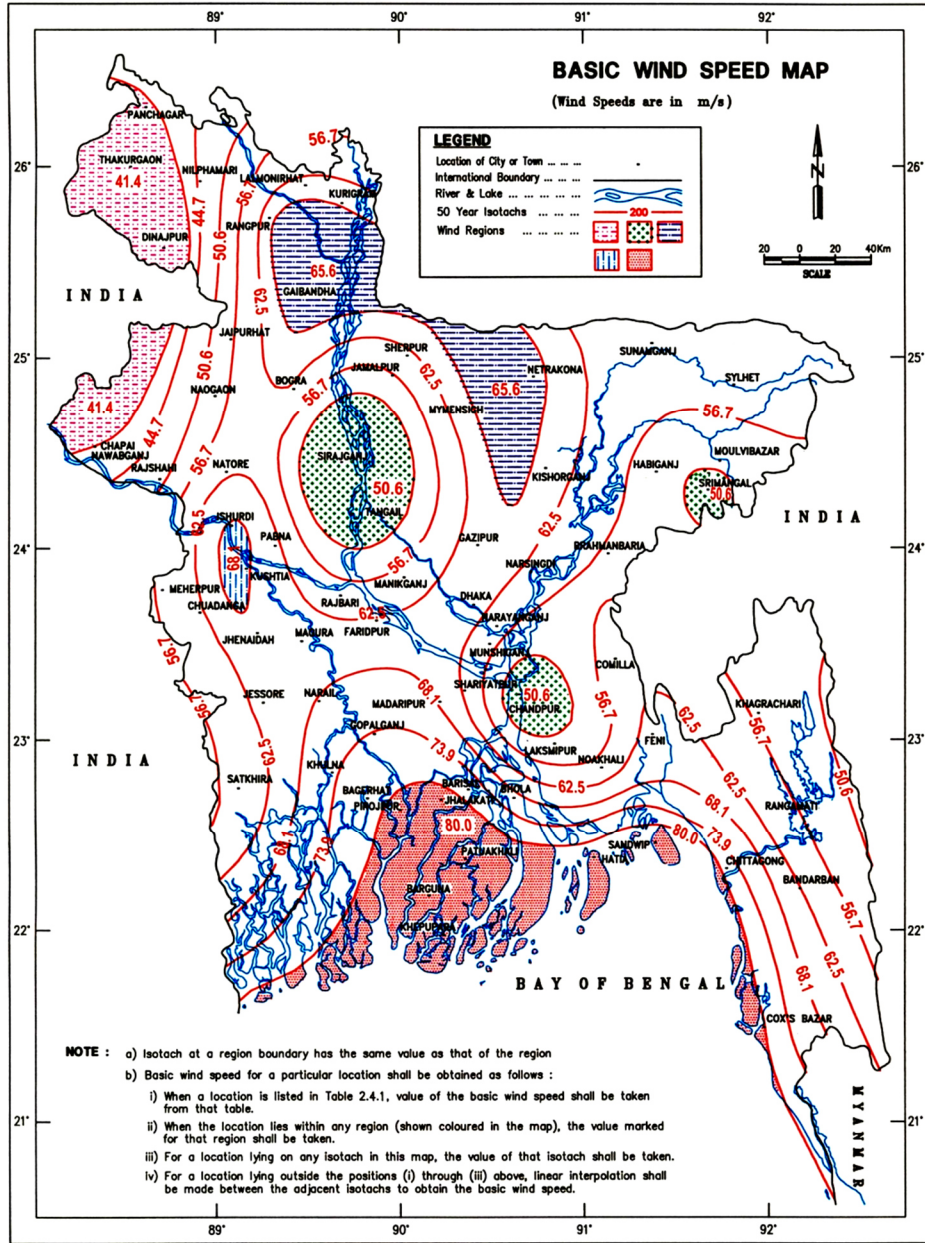


Figure 6.2.1 Basic wind speed (V , m/s) map of Bangladesh

2.4.5 Importance Factor

An importance factor, I for the building or other structure shall be determined from Table 6.2.9 based on building and structure categories listed in Sec 1.2.4.

2.4.6 Exposure

For each wind direction considered, the upwind exposure category shall be based on ground surface roughness that is determined from natural topography, vegetation, and constructed facilities.

2.4.6.1 Wind directions and sectors

For each selected wind direction at which the wind loads are to be evaluated, the exposure of the building or structure shall be determined for the two upwind sectors extending 45° either side of the selected wind direction.

The exposures in these two sectors shall be determined in accordance with Sections 2.4.6.2 and 2.4.6.3 and the exposure resulting in the highest wind loads shall be used to represent the winds from that direction.

2.4.6.2 Surface roughness categories

A ground surface roughness within each 45° sector shall be determined for a distance upwind of the site as defined in Sec 2.4.6.3 from the categories defined in the following text, for the purpose of assigning an exposure category as defined in Sec 2.4.6.3.

Surface Roughness A: Urban and suburban areas, wooded areas, or other terrain with numerous closely spaced obstructions having the size of single-family dwellings or larger.

Surface Roughness B: Open terrain with scattered obstructions having heights generally less than 9.1 m. This category includes flat open country, grasslands, and all water surfaces in cyclone prone regions.

Surface Roughness C: Flat, unobstructed areas and water surfaces outside cyclone prone regions. This category includes smooth mud flats and salt flats.

2.4.6.3 Exposure categories

Exposure A: Exposure A shall apply where the ground surface roughness condition, as defined by Surface Roughness A, prevails in the upwind direction for a distance of at least 792 m or 20 times the height of the building, whichever is greater.

Exception: For buildings whose mean roof height is less than or equal to 9.1 m, the upwind distance may be reduced to 457 m.

Exposure B: Exposure B shall apply for all cases where Exposures A or C do not apply.

Exposure C: Exposure C shall apply where the ground surface roughness, as defined by Surface Roughness C, prevails in the upwind direction for a distance greater than 1,524 m or 20 times the building height, whichever is greater. Exposure C shall extend into downwind areas of Surface Roughness A or B for a distance of 200 m or 20 times the height of the building, whichever is greater.

For a site located in the transition zone between exposure categories, the category resulting in the largest wind forces shall be used.

Exception: An intermediate exposure between the preceding categories is permitted in a transition zone provided that it is determined by a rational analysis method defined in the recognized literature.

2.4.6.4 Exposure category for main wind-force resisting system

Buildings and Other Structures: For each wind direction considered, wind loads for the design of the MWFRS determined from Figure 6.2.6 shall be based on the exposure categories defined in Sec 2.4.6.3.

Low-Rise Buildings: Wind loads for the design of the MWFRSs for low-rise buildings shall be determined using a velocity pressure q_h based on the exposure resulting in the highest wind loads for any wind direction at the site where external pressure coefficients GC_{pf} given in Figure 6.2.10 are used.

2.4.6.5 Exposure category for components and cladding

Components and cladding design pressures for all buildings and other structures shall be based on the exposure resulting in the highest wind loads for any direction at the site.

2.4.6.6 Velocity pressure exposure coefficient

Based on the exposure category determined in Sec 2.4.6.3, a velocity pressure exposure coefficient K_z or K_h , as applicable, shall be determined from Table 6.2.11. For a site located in a transition zone between exposure categories that is near to a change in ground surface roughness, intermediate values of K_z or K_h between those shown in Table 6.2.11, are permitted, provided that they are determined by a rational analysis method defined in the recognized literature.

2.4.7 Topographic Effects

2.4.7.1 Wind speed-up over hills, ridges and escarpments

Wind speed-up effects at isolated hills, ridges, and escarpments constituting abrupt changes in the general topography located in any exposure category shall be included in the design when buildings and other site conditions and locations of structures meet all of the following conditions:

- (i) The hill, ridge, or escarpment is isolated and unobstructed upwind by other similar topographic features of comparable height for 100 times the height of the topographic feature (100 H) or 3.22 km, whichever is less. This distance shall be measured horizontally from the point at which the height H of the hill, ridge, or escarpment is determined.
- (ii) The hill, ridge, or escarpment protrudes above the height of upwind terrain features within a 3.22 km radius in any quadrant by a factor of two or more.
- (iii) The structure is located as shown in Figure 6.2.4 in the upper one-half of a hill or ridge or near the crest of an escarpment.
- (iv) $H/L_h \geq 0.2$
- (v) H is greater than or equal to 4.5 m for Exposures B and C and 18.3 m for Exposure A.

2.4.7.2 Topographic factor

The wind speed-up effect shall be included in the calculation of design wind loads by using the factor K_{zt} :

$$K_{zt} = (1 + K_1 K_2 K_3)^2 \quad (6.2.5)$$

Where, K_1 , K_2 , and K_3 are given in Figure 6.2.4. If site conditions and locations of structures do not meet all the conditions specified in Sec 2.4.7.1 then $K_{zt} = 1.0$.

2.4.8 Gust Effect Factor

2.4.8.1 Rigid structures

For rigid structures as defined in Sec 2.1.3, the gust-effect factor shall be taken as 0.85 or calculated by the formula:

$$G = 0.925 \frac{1+1.7g_Q I_z Q}{1+1.7g_v I_z} \quad (6.2.6)$$

$$I_z = c \left(\frac{10}{z} \right)^{1/6} \quad (6.2.7)$$

Where, $I_{\bar{z}}$ = the intensity of turbulence at height \bar{z} where \bar{z} = the equivalent height of the structure defined as $0.6h$, but not less than z_{min} for all building heights h . z_{min} and c are listed for each exposure in Table 6.2.10; g_Q and the value of g_V shall be taken as 3.4. The background response Q is given by

$$Q = \sqrt{\frac{1}{1+0.63\left(\frac{B+h}{L_{\bar{z}}}\right)^{0.63}}} \quad (6.2.8)$$

Where, B , h are defined in Sec 2.1.4; and $L_{\bar{z}}$ = the integral length scale of turbulence at the equivalent height given by

$$L_{\bar{z}} = l \left(\frac{\bar{z}}{10}\right)^{\bar{e}} \quad (6.2.9)$$

In which l and \bar{e} are constants listed in Table 6.2.10.

2.4.8.2 Flexible or dynamically sensitive structures

For flexible or dynamically sensitive structures as defined in Sec 2.1.3 (natural period greater than 1.0 second), the gust-effect factor shall be calculated by

$$G_f = 0.925 \left(\frac{1+1.7I_{\bar{z}}\sqrt{g_Q^2Q^2+g_R^2R^2}}{1+1.7g_VI_{\bar{z}}} \right) \quad (6.2.10)$$

The value of both g_Q and g_V shall be taken as 3.4 and g_R is given by

$$g_R = \sqrt{2 \ln(3600n_1)} + \frac{0.577}{\sqrt{2 \ln(3600n_1)}} \quad (6.2.11)$$

R , the resonant response factor, is given by

$$R = \sqrt{\frac{1}{\beta} R_n R_h R_B (0.53 + 0.47R_L)} \quad (6.2.12)$$

$$R_n = \frac{7.47N_1}{(1+10.3N_1)^{5/3}} \quad (6.2.13)$$

$$N_1 = \frac{n_1 L_{\bar{z}}}{\bar{V}_{\bar{z}}} \quad (6.2.14)$$

$$R_l = \frac{1}{\eta} - \frac{1}{2\eta^2} (1 - e^{-2\eta}) \text{ for } \eta > 0 \quad (6.2.15a)$$

$$R_l = 1 \text{ for } \eta = 0 \quad (6.2.15b)$$

Where, the subscript l in Eq. 6.2.15 shall be taken as h , B , and L , respectively, where h , B , and L are defined in Sec 2.1.4.

n_1 = building natural frequency

$R_l = R_h$ setting $\eta = 4.6n_1h/\bar{V}_{\bar{z}}$

$R_l = R_B$ setting $\eta = 4.6n_1B/\bar{V}_{\bar{z}}$

$R_l = R_L$ setting $\eta = 15.4n_1L/\bar{V}_{\bar{z}}$

β = damping ratio, percent of critical

$\bar{V}_{\bar{z}}$ = mean hourly wind speed at height \bar{z} determined from Eq. 6.2.16.

$$\bar{V}_{\bar{z}} = \bar{v} \left(\frac{\bar{z}}{10}\right)^{\bar{c}} V \quad (6.2.16)$$

Where, \bar{b} and $\bar{\alpha}$ are constants listed in Table 6.2.10.

2.4.8.3 Rational analysis

In lieu of the procedure defined in Sections 2.4.8.1 and 2.4.8.2, determination of the gust-effect factor by any rational analysis defined in the recognized literature is permitted.

2.4.8.4 Limitations

Where combined gust-effect factors and pressure coefficients (GC_p, GC_{pi}, GC_{pf}) are given in figures and tables, the gust-effect factor shall not be determined separately.

2.4.9 Enclosure Classifications

2.4.9.1 General

For the purpose of determining internal pressure coefficients, all buildings shall be classified as enclosed, partially enclosed, or open as defined in Sec 2.1.3.

2.4.9.2 Openings

A determination shall be made of the amount of openings in the building envelope to determine the enclosure classification as defined in Sec 2.4.9.3.

2.4.9.3 Wind-borne debris

Glazing in buildings located in wind-borne debris regions shall be protected with an impact-resistant covering or be impact-resistant glazing according to the requirements specified in ASTM E1886 and ASTM E1996 or other approved test methods and performance criteria. The levels of impact resistance shall be a function of Missile Levels and Wind Zones specified in ASTM E1886 and ASTM E1996.

Exceptions:

- (i) Glazing in Category II, III, or IV buildings located over 18.3 m above the ground and over 9.2 m above aggregate surface roofs located within 458 m of the building shall be permitted to be unprotected.
- (ii) Glazing in Category I buildings shall be permitted to be unprotected.

2.4.9.4 Multiple classifications

If a building by definition complies with both the “open” and “partially enclosed” definitions, it shall be classified as an “open” building. A building that does not comply with either the “open” or “partially enclosed” definitions shall be classified as an “enclosed” building.

2.4.9.5 Velocity pressure

Velocity pressure, q_z evaluated at height z shall be calculated by the following equation:

$$q_z = 0.000613K_zK_{zt}K_dV^2I; \text{ (kN/m}^2\text{), } V \text{ in m/s} \quad (6.2.17)$$

Where K_d is the wind directionality factor, K_z is the velocity pressure exposure coefficient defined in Sec 2.4.6.6, K_{zt} is the topographic factor defined in Sec 2.4.7.2, and q_z is the velocity pressure calculated using Eq. 6.2.17 at mean roof height h . The numerical coefficient 0.000613 shall be used except where sufficient climatic data are available to justify the selection of a different value of this factor for a design application.

2.4.10 Pressure And Force Coefficients

2.4.10.1 Internal pressure coefficients

Internal Pressure Coefficient. Internal pressure coefficients, GC_{pi} shall be determined from Figure 6.2.5 based on building enclosure classifications determined from Sec 2.4.9.

Reduction Factor for Large Volume Buildings, R_i : For a partially enclosed building containing a single, unpartitioned large volume, the internal pressure coefficient, GC_{pi} shall be multiplied by the following reduction factor, R_i :

$$R_i = 1.0 \quad \text{or} \quad R_i = 0.5 \left(1 + \frac{1}{\sqrt{1 + \frac{V_i}{6951A_{og}}}} \right) \leq 1.0 \quad (6.2.18)$$

Where, A_{og} = total area of openings in the building envelope (walls and roof, in m²)

V_i = unpartitioned internal volume, in m³

2.4.10.2 External pressure coefficients

Main Wind-Force Resisting Systems: External pressure coefficients for MWFRSs C_p are given in Figures 6.2.6 to 6.2.8. Combined gust effect factor and external pressure coefficients, GC_{pf} are given in Figure 6.2.10 for low-rise buildings. The pressure coefficient values and gust effect factor in Figure 6.2.10 shall not be separated.

Components and Cladding: Combined gust effect factor and external pressure coefficients for components and cladding GC_p are given in Figures 6.2.11 to 6.2.17. The pressure coefficient values and gust-effect factor shall not be separated.

2.4.10.3 Force coefficients

Force coefficients C_f are given in Figures 6.2.20 to 6.2.23.

2.4.10.4 Roof overhangs

Main Wind-Force Resisting System: Roof overhangs shall be designed for a positive pressure on the bottom surface of windward roof overhangs corresponding to $C_p = 0.8$ in combination with the pressures determined from using Figures 6.2.6 and 6.2.10.

Components and Cladding: For all buildings, roof overhangs shall be designed for pressures determined from pressure coefficients given in Figure 6.2.11.

2.4.10.5 Parapets

Main Wind-Force Resisting System: The pressure coefficients for the effect of parapets on the MWFRS loads are given in Sec 2.4.12.2.

Components and Cladding: The pressure coefficients for the design of parapet component and cladding elements are taken from the wall and roof pressure coefficients as specified in Sec 2.4.12.3.

2.4.11 Design Wind Loads on Enclosed and Partially Enclosed Buildings

2.4.11.1 General

Sign Convention: Positive pressure acts toward the surface and negative pressure acts away from the surface.

Critical Load Condition: Values of external and internal pressures shall be combined algebraically to determine the most critical load.

Tributary Areas Greater than 65 m²: Component and cladding elements with tributary areas greater than 65 m² shall be permitted to be designed using the provisions for MWFRSs.

2.4.11.2 Main wind-force resisting systems

Rigid Buildings of All Heights: Design wind pressures for the MWFRS of buildings of all heights shall be determined by the following equation:

$$p = qGC_p - q_i(GC_{pi}) \quad (\text{kN/m}^2) \quad (6.2.19)$$

Where,

$q = q_z$ for windward walls evaluated at height z above the ground

$q = q_h$ for leeward walls, side walls, and roofs, evaluated at height h

$q_i = q_h$ for windward walls, side walls, leeward walls, and roofs of enclosed buildings and for negative internal pressure evaluation in partially enclosed buildings.

$q_i = q_z$ for positive internal pressure evaluation in partially enclosed buildings where height z is defined as the level of the highest opening in the building that could affect the positive internal pressure. For buildings sited in wind-borne debris regions, glazing that is not impact resistant or protected with an impact resistant covering, shall be treated as an opening in accordance with Sec 2.4.9.3. For positive internal pressure evaluation, q_i may conservatively be evaluated at height $h = (q_i = q_h)$

G = gust effect factor from Sec 2.4.8

C_p = external pressure coefficient from Figures 6.2.6 or 6.2.8

GC_{pi} = internal pressure coefficient from Figure 6.2.5

q and q_i shall be evaluated using exposure defined in Sec 2.4.6.3. Pressure shall be applied simultaneously on windward and leeward walls and on roof surfaces as defined in Figures 6.2.6 and 6.2.8.

Low-Rise Building: Alternatively, design wind pressures for the MWFRS of low-rise buildings shall be determined by the following equation:

$$p = q_h [(GC_{pf}) - (GC_{pi})] \text{ (kN/m}^2\text{)} \quad (6.2.20)$$

Where,

q_h = velocity pressure evaluated at mean roof height h using exposure defined in Sec 2.4.6.3

GC_{pf} = external pressure coefficient from Figure 6.2.10

GC_{pi} = internal pressure coefficient from Figure 6.2.5

Flexible Buildings: Design wind pressures for the MWFRS of flexible buildings shall be determined from the following equation:

$$p = qG_f C_p - q_i (GC_{pi}) \text{ (kN/m}^2\text{)} \quad (6.2.21)$$

Where, q , q_i , C_p , and GC_{pi} are as defined in Sec 2.4.11.2 and G_f = gust effect factor is defined as in Sec 2.4.8.

Parapets: The design wind pressure for the effect of parapets on MWFRSs of rigid, low-rise, or flexible buildings with flat, gable, or hip roofs shall be determined by the following equation:

$$p_p = q_p GC_{pn} \text{ (kN/m}^2\text{)} \quad (6.2.22)$$

Where,

p_p = Combined net pressure on the parapet due to the combination of the net pressures from the front and back parapet surfaces. Plus (and minus) signs signify net pressure acting toward (and away from) the front (exterior) side of the parapet

q_p = Velocity pressure evaluated at the top of the parapet

GC_{pn} = Combined net pressure coefficient

= +1.5 for windward parapet

= -1.0 for leeward parapet

2.4.11.3 Design wind load cases

The MWFRS of buildings of all heights, whose wind loads have been determined under the provisions of Sec 2.4.11.2, shall be designed for the wind load cases as defined in Figure 6.2.9. The eccentricity e for rigid structures shall be measured from the geometric center of the building face and shall be considered for each principal axis (e_x, e_y). The eccentricity e for flexible structures shall be determined from the following equation and shall be considered for each principal axis (e_x, e_y):

$$e = \frac{e_Q + 1.7I_z \sqrt{(g_Q Q e_Q)^2 + (g_R R e_R)^2}}{1 + 1.7I_z \sqrt{(g_Q Q)^2 + (g_R R)^2}} \quad (6.2.23)$$

Where,

e_Q = Eccentricity e as determined for rigid structures in Figure 6.2.9

e_R = Distance between the elastic shear center and center of mass of each floor

I_z, g_Q, Q, g_R, R shall be as defined in Sec 2.1.4

The sign of the eccentricity e shall be plus or minus, whichever causes the more severe load effect.

Exception: One-story buildings with h less than or equal to 9.1 m, buildings two stories or less framed with light-frame construction, and buildings two stories or less designed with flexible diaphragms need only be designed for Load Case 1 and Load Case 3 in Figure 6.2.9.

2.4.11.4 Components and cladding.

Low-Rise Buildings and Buildings with $h \leq 18.3$ m: Design wind pressures on component and cladding elements of low-rise buildings and buildings with $h \leq 18.3$ m shall be determined from the following equation:

$$p = q_h[(GC_p) - (GC_{pi})] \text{ (kN/m}^2\text{)} \quad (6.2.24)$$

Where,

q_h = Velocity pressure evaluated at mean roof height h using exposure defined in Sec 2.4.6.5

GC_p = External pressure coefficients given in Figures 6.2.11 to 6.2.16

GC_{pi} = Internal pressure coefficient given in Figure 6.2.5

Buildings with $h > 18.3$ m: Design wind pressures on components and cladding for all buildings with $h > 18.3$ m shall be determined from the following equation:

$$p = q(GC_p) - q_i(GC_{pi}) \text{ (kN/m}^2\text{)} \quad (6.2.25)$$

Where,

$q = q_z$ for windward walls calculated at height z above the ground

$q = q_h$ for leeward walls, side walls, and roofs, evaluated at height h

$q_i = q_h$ for windward walls, side walls, leeward walls, and roofs of enclosed buildings and for negative internal pressure evaluation in partially enclosed buildings

$q_i = q_z$ for positive internal pressure evaluation in partially enclosed buildings where height z is defined as the level of the highest opening in the building that could affect the positive internal pressure. For buildings sited in wind-borne debris regions, glazing that is not impact resistant or protected with an impact-resistant covering, shall be treated as an opening in accordance with Sec 2.4.9.3. For positive internal pressure evaluation, q_i may conservatively be evaluated at height h ($q_i = q_h$)

(GC_p) = external pressure coefficient from Figure 6.2.17.

(GC_{pi}) = internal pressure coefficient given in Figure 6.2.5. q and q_i shall be evaluated using exposure defined in Sec 2.4.6.3.

2.4.11.5 Alternative design wind pressures for components and cladding in buildings with $18.3 \text{ m} < h < 27.4 \text{ m}$.

Alternative to the requirements of Sec 2.4.11.2, the design of components and cladding for buildings with a mean roof height greater than 18.3 m and less than 27.4 m values from Figures 6.2.11 to 6.2.17 shall be used only if the height to width ratio is one or less (except as permitted by Notes of Figure 6.2.17) and Eq. 6.2.24 is used.

Parapets: The design wind pressure on the components and cladding elements of parapets shall be designed by the following equation:

$$p = q_p(GC_p - GC_{pi}) \quad (6.2.26)$$

Where,

q_p = Velocity pressure evaluated at the top of the parapet

GC_p = External pressure coefficient from Figures 6.2.11 to 6.2.17

GC_{pi} = Internal pressure coefficient from Figure 6.2.5, based on the porosity of the parapet envelope.

Two load cases shall be considered. Load Case A shall consist of applying the applicable positive wall pressure from Figures 6.2.11 or 6.2.17 to the front surface of the parapet while applying the applicable negative edge or corner zone roof pressure from Figures 6.2.11 to 6.2.17 to the back surface. Load Case B shall consist of applying the applicable positive wall pressure from Figures 6.2.11 or 6.2.17 to the back of the parapet surface, and applying the applicable negative wall pressure from Figures 6.2.11 or 6.2.17 to the front surface. Edge and corner zones shall be arranged as shown in Figures 6.2.11 to 6.2.17. GC_p shall be determined for appropriate roof angle and effective wind area from Figures 6.2.11 to 6.2.17. If internal pressure is present, both load cases should be evaluated under positive and negative internal pressure.

2.4.12 Design Wind Loads on Open Buildings with Monoslope, Pitched, or Troughed Roofs

2.4.12.1 General

Sign Convention: Plus and minus signs signify pressure acting toward and away from the top surface of the roof, respectively.

Critical Load Condition: Net pressure coefficients C_N include contributions from top and bottom surfaces. All load cases shown for each roof angle shall be investigated.

2.4.12.2 Main wind-force resisting systems

The net design pressure for the MWFRSs of monoslope, pitched, or troughed roofs shall be determined by the following equation:

$$p = q_h G C_N \quad (6.2.27)$$

Where,

q_h = Velocity pressure evaluated at mean roof height h using the exposure as defined in Sec 2.4.6.3 that results in the highest wind loads for any wind direction at the site

G = Gust effect factor from Sec 2.4.8

C_N = Net pressure coefficient determined from Figures 6.2.18(a) to 6.2.18(d).

For free roofs with an angle of plane of roof from horizontal θ less than or equal to 5° and containing fascia panels, the fascia panel shall be considered an inverted parapet. The contribution of loads on the fascia to the MWFRS loads shall be determined using Sec 2.4.11.5 with q_p equal to q_h .

2.4.12.3 Component and cladding elements

The net design wind pressure for component and cladding elements of monoslope, pitched, and troughed roofs shall be determined by the following equation:

$$p = q_h G C_N \quad (6.2.28)$$

Where,

q_h = Velocity pressure evaluated at mean roof height h using the exposure as defined in Sec 2.4.6.3 that results in the highest wind loads for any wind direction at the site

G = Gust-effect factor from Sec 2.4.8

C_N = Net pressure coefficient determined from Figures 6.2.19(a) to 6.2.19(c).

2.4.13 Design Wind Loads on Solid Free Standing Walls and Solid Signs

The design wind force for solid freestanding walls and solid signs shall be determined by the following formula:

$$F = q_h G C_f A_s \text{ (kN)} \quad (6.2.29)$$

Where,

q_h = Velocity pressure evaluated at height h (Figure 6.2.20) using exposure defined in Sec 2.4.6.3

G = Gust-effect factor from Sec 2.4.8

C_f = Net force coefficient from Figure 6.2.20

A_s = Gross area of the solid freestanding wall or solid sign, in m^2

2.4.14 Design Wind Loads on Other Structures

The design wind force for other structures shall be determined by the following equation:

$$F = q_z G C_f A_f \text{ (kN)} \quad (6.2.30)$$

Where,

q_z = Velocity pressure evaluated at height z of the centroid of area A_f using exposure as in Sec 2.4.6.3

G = Gust-effect factor from Sec 2.4.8

C_f = Force coefficients from Figures 6.2.21 to 6.2.23.

A_f = Projected area normal to the wind except where C_f is specified for the actual surface area, m^2

2.4.15 Rooftop Structures and Equipment for Buildings with $h \leq 18.3$ m

The force on rooftop structures and equipment with A_f less than $(0.1Bh)$ located on buildings with $h \leq 18.3$ m shall be determined from Eq. 6.2.30, increased by a factor of 1.9. The factor shall be permitted to be reduced linearly from 1.9 to 1.0 as the value of A_f is increased from $(0.1Bh)$ to (Bh) .

2.4.16 Method 3 - Wind Tunnel Procedure

2.4.16.1 Scope

Wind tunnel tests shall be used where required by Sec 2.4.3.1. Wind tunnel testing shall be permitted in lieu of Methods 1 and 2 for any building or structure.

2.4.16.2 Test conditions

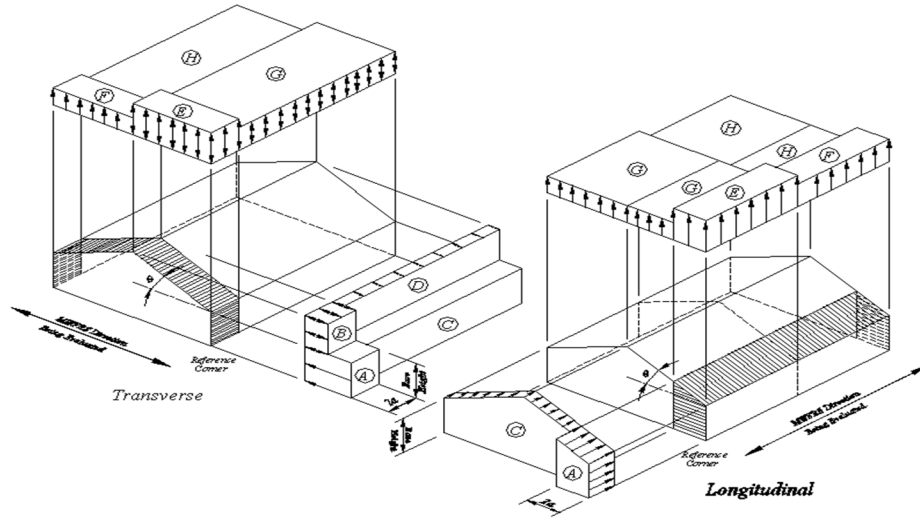
Wind tunnel tests, or similar tests employing fluids other than air, used for the determination of design wind loads for any building or other structure, shall be conducted in accordance with this Section. Tests for the determination of mean and fluctuating forces and pressures shall meet all of the following conditions:

- (i) Natural atmospheric boundary layer has been modeled to account for the variation of wind speed with height.
- (ii) The relevant macro- (integral) length and micro-length scales of the longitudinal component of atmospheric turbulence are modeled to approximately the same scale as that used to model the building or structure.
- (iii) The modeled building or other structure and surrounding structures and topography are geometrically similar to their full-scale counterparts, except that, for low-rise buildings meeting the requirements of Sec 2.4.3.1, tests shall be permitted for the modeled building in a single exposure site as in Sec 2.4.6.
- (iv) The projected area of the modeled building or other structure and surroundings is less than 8 percent of the test section cross-sectional area unless correction is made for blockage.
- (v) The longitudinal pressure gradient in the wind tunnel test section is accounted for.
- (vi) Reynolds number effects on pressures and forces are minimized.
- (vii) Response characteristics of the wind tunnel instrumentation are consistent with the required measurements.

2.4.17 Dynamic Response

Tests for the purpose of determining the dynamic response of a building or other structure shall be in accordance with Sec 2.4.16.2. The structural model and associated analysis shall account for mass distribution, stiffness, and damping.

Enclosed Buildings: Walls & Roofs



Notes:

1. Pressures shown are applied to the horizontal and vertical projections, for exposure A, at $h=9.1\text{m}$, $I=1.0$, and $K_{zt} = 1.0$. Adjust to other conditions using Equation 6.2.3.
2. The load patterns shown shall be applied to each corner of the building in turn as the reference corner. (See Figure 6.2.10)
3. For the design of the longitudinal MWFRS use $\theta = 0^\circ$, and locate the zone E/F, G/H boundary at the mid-length of the building.
4. Load cases 1 and 2 must be checked for $25^\circ < \theta \leq 45^\circ$. Load case 2 at 25° is provided only for interpolation between 25° to 30° .
5. Plus and minus signs signify pressures acting toward and away from the projected surfaces, respectively.
6. For roof slopes other than those shown, linear interpolation is permitted.
7. The total horizontal load shall not be less than that determined by assuming $p_s = 0$ in zones B & D.
8. The zone pressures represent the following:
Horizontal pressure zones – Sum of the windward and leeward net (sum of internal and external) pressures on vertical projection of:

A - End zone of wall	C - Interior zone of wall
B - End zone of roof	D - Interior zone of roof

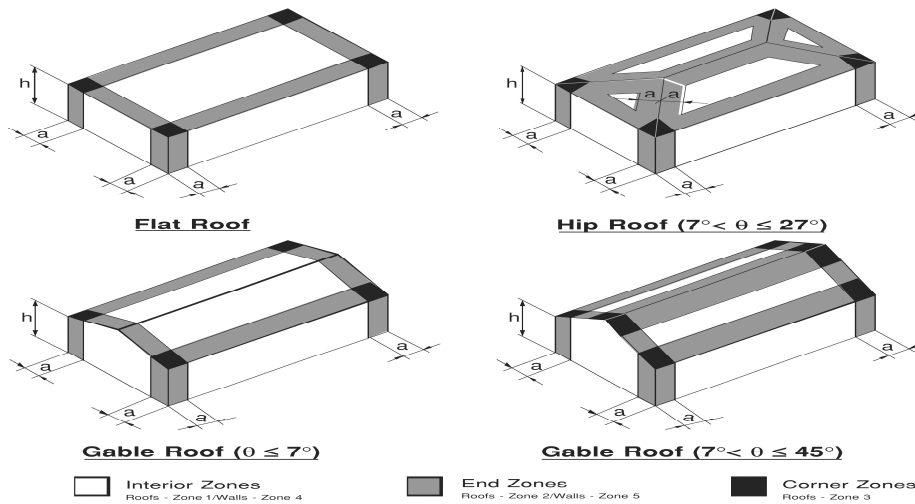
Vertical pressure zones – Net (sum of internal and external) pressures on horizontal projection of:

E - End zone of windward roof	G - Interior zone of windward roof
F - End zone of leeward roof	H - Interior zone of leeward roof
9. Where zone E or G falls on a roof overhang on the windward side of the building, use EOH and GOH for the pressure on the horizontal projection of the overhang. Overhangs on the leeward and side edges shall have the basic zone pressure applied.
10. Notation:
 a : 10 percent of least horizontal dimension or $0.4h$, whichever is smaller, but not less than either 4% of least horizontal dimension or 0.9 m.
 h : Mean roof height, in feet (meters), except that eave height shall be used for roof angles $<10^\circ$.
 θ : Angle of plane of roof from horizontal, in degrees.

Adjustment Factor for Building Height and Exposure, λ			
Mean roof height (m)	Exposure		
	A	B	C
4.6	1.00	1.21	1.47
6.0	1.00	1.29	1.55
7.6	1.00	1.35	1.61
9.1	1.00	1.40	1.66
10.7	1.05	1.45	1.70
12.2	1.09	1.49	1.74
13.7	1.12	1.53	1.78
15.2	1.16	1.56	1.81
16.8	1.19	1.59	1.84
18.3	1.22	1.62	1.87

Figure 6.2.2 Design wind pressure for main wind force resisting system- Method 1 ($h \leq 18.3$ m)

Enclosed Buildings: Walls & Roofs



Notes:

- Pressures shown are applied normal to the surface, for exposure A, at $h = 9.1$ m, $I = 1.0$, and $K_{zt} = 1.0$. Adjust to other conditions using Equation 6.2.4.
- Plus and minus signs signify pressures acting toward and away from the surfaces, respectively.
- For hip roofs with $\theta \leq 25^\circ$, Zone 3 shall be treated as Zone 2.
- For effective wind areas between those given, value may be interpolated, otherwise use the value associated with the lower effective wind area.
- Notation:
 - a : 10 percent of least horizontal dimension or $0.4h$, whichever is smaller, but not less than either 4% of least horizontal dimension or 0.9 m.
 - h : Mean roof height, in feet (meters), except that eave height shall be used for roof angles $< 10^\circ$.
 - θ : Angle of plane of roof from horizontal, in degrees.

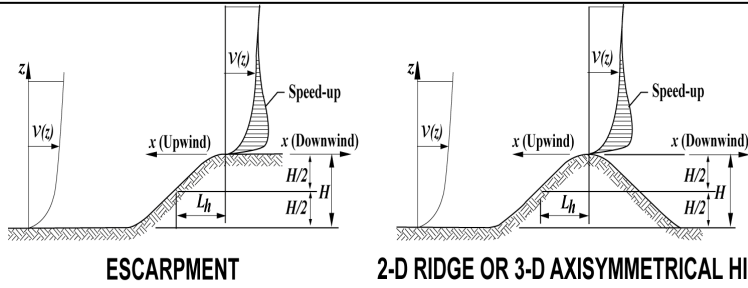
Roof Overhang Net Design Wind Pressure, P_{net30} (kN/m ²) (Exposure A at $h = 9.1$ m with $l = 1.0$)										
Roof Pitch	Zone	Effective Wind area (m ²)	Basic Wind Speed V (m/s)							
			40.23	44.7	49.17	53.64	58.11	62.58	67.05	75.99
Roof 0 to 7 degrees	2	0.930	-1.005	-1.239	-1.502	-1.785	-2.096	-2.431	-2.790	-3.584
	2	1.860	-0.986	-1.220	-1.473	-1.756	-2.058	-2.388	-2.742	-3.522
	2	4.648	-0.962	-1.191	-1.440	-1.713	-2.010	-2.330	-2.675	-3.436
	2	9.296	-0.947	-1.168	-1.412	-1.680	-1.971	-2.287	-2.627	-3.373
	3	0.930	-1.656	-2.043	-2.470	-2.943	-3.450	-4.005	-4.594	-5.905
	3	1.860	-1.297	-1.603	-1.938	-2.311	-2.708	-3.144	-3.609	-4.632
	3	4.648	-0.828	-1.024	-1.240	-1.474	-1.727	-2.005	-2.302	-2.957
	3	9.296	-0.479	-0.584	-0.708	-0.842	-0.986	-1.144	-1.311	-1.684

Figure 6.2.3 Design wind pressure for components and cladding - Method 1 ($h \leq 18.3$ m)

Roof Overhang Net Design Wind Pressure, P_{net30} (kN/m ²) (Exposure A at $h = 9.1$ m with $l = 1.0$)										
Roof Pitch	Zone	Effective Wind area (m ²)	Basic Wind Speed V (m/s)							
			40.23	44.7	49.17	53.64	58.11	62.58	67.05	75.99
Roof > 7 to 27 degrees	2	0.930	-1.302	-1.603	-1.943	-2.311	-2.713	-3.144	-3.613	-4.637
	2	1.860	-1.302	-1.603	-1.943	-2.311	-2.713	-3.144	-3.613	-4.637
	2	4.648	-1.302	-1.603	-1.943	-2.311	-2.713	-3.144	-3.613	-4.637
	2	9.296	-1.302	-1.603	-1.943	-2.311	-2.713	-3.144	-3.613	-4.637
	3	0.930	-2.187	-2.699	-3.268	-3.885	-4.560	-5.292	-6.072	-7.800
	3	1.860	-1.971	-2.436	-2.948	-3.507	-4.115	-4.775	-5.479	-7.039
	3	4.648	-1.689	-2.086	-2.526	-3.005	-3.526	-4.091	-4.694	-6.034
	3	9.296	-1.479	-1.823	-2.206	-2.627	-3.082	-3.574	-4.106	-5.268

Roof >27 to 45 degrees	2	0.930	-1.182	-1.460	-1.766	-2.101	-2.464	-2.861	-3.282	-4.216
	2	1.860	-1.148	-1.416	-1.713	-2.038	-2.393	-2.775	-3.182	-4.091
	2	4.648	-1.101	-1.359	-1.641	-1.952	-2.292	-2.660	-3.052	-3.924
	2	9.296	-1.062	-1.311	-1.587	-1.890	-2.220	-2.574	-2.952	-3.795
	3	0.930	-1.182	-1.460	-1.766	-2.101	-2.464	-2.861	-3.283	-4.216
	3	1.860	-1.148	-1.416	-1.713	-2.038	-2.393	-2.775	-3.182	-4.091
	3	4.648	-1.101	-1.359	-1.641	-1.952	-2.292	-2.660	-3.053	-3.923
	3	9.296	-1.062	-1.311	-1.589	-1.890	-2.220	-2.574	-2.952	-3.795
Adjustment Factor for Building Height and Exposure, λ										
Mean roof height (m)		Exposure								
		A	B		C					
4.6		1.00	1.21		1.47					
6.1		1.00	1.29		1.55					
7.6		1.00	1.35		1.61					
9.15		1.00	1.40		1.66					
10.7		1.05	1.45		1.70					
12.2		1.09	1.49		1.74					
13.7		1.12	1.53		1.78					
15.2		1.16	1.56		1.81					
16.8		1.19	1.59		1.84					
18.3		1.22	1.62		1.87					
Unit Conversion – 1.0 ft = 0.3048 m; 1.0 ft ² = 0.0929 m ² ; 1.0 psf = 0.0479 kN/m ²										

Figure 6.2.3 (Contd.) Design wind pressure for components and cladding-Method 1
($h \leq 18.3$ m)



ESCARPMENT

2-D RIDGE OR 3-D AXISYMMETRICAL HILL

Topographic Multipliers for Exposure B

H/L_h	K_1 Multiplier			x/L_h	K_2 Multiplier		z/L_h	K_3 Multiplier		
	2-D Ridge	2-D Escarp.	3-D Axisym. Hill		2-D Escarp.	All Other Cases		2-D Ridge	2-D Escarp.	3-D Axisym. Hill
0.20	0.29	0.17	0.21	0.00	1.00	1.00	0.00	1.00	1.00	1.00
0.25	0.36	0.21	0.26	0.50	0.88	0.67	0.10	0.74	0.78	0.67
0.30	0.43	0.26	0.32	1.00	0.75	0.33	0.20	0.55	0.61	0.45
0.35	0.51	0.30	0.37	1.50	0.63	0.00	0.30	0.41	0.47	0.30
0.40	0.58	0.34	0.42	2.00	0.50	0.00	0.40	0.30	0.37	0.20
0.45	0.65	0.38	0.47	2.50	0.38	0.00	0.50	0.22	0.29	0.14
0.50	0.72	0.43	0.53	3.00	0.25	0.00	0.60	0.17	0.22	0.09
				3.50	0.13	0.00	0.70	0.12	0.17	0.06
				4.00	0.00	0.00	0.80	0.09	0.14	0.04
							0.90	0.07	0.11	0.03
							1.00	0.05	0.08	0.02
							1.50	0.01	0.02	0.00
							2.00	0.00	0.00	0.00

Notes:

1. For values of H/L_h , x/L_h and z/L_h other than those shown, linear interpolation is permitted.
2. For $H/L_h > 0.5$, assume $H/L_h = 0.5$ for evaluating K_1 and substitute $2H$ for L_h for evaluating K_2 and K_3 .
3. Multipliers are based on the assumption that wind approaches the hill or escarpment along the direction of maximum slope.
4. Notation:

H : Height of hill or escarpment relative to the upwind terrain, in meters.

L_h : Distance upwind of crest to where the difference in ground elevation is half the height of hill or escarpment, in meters.

K_1 : Factor to account for shape of topographic feature and maximum speed-up effect.

K_2 : Factor to account for reduction in speed-up with distance upwind or downwind of crest.

K_3 : Factor to account for reduction in speed-up with height above local terrain.

x : Distance (upwind or downwind) from the crest to the building site, in meters.

z : Height above local ground level, in meters.

W : Horizontal attenuation factor.

γ : Height attenuation factor

Equation:

$$K_{zt} = (1 + K_1 K_2 K_3)^2; K_1 \text{ determined from Table below; } K_2 = \left(1 - \frac{|x|}{\mu L_h}\right); K_3 = e^{-\gamma z/L_h}$$

Parameters for Speed-Up Over Hills and Escarpments						
Hill Shape	$K_1/(H/L_h)$			γ	μ	
	Exposure A	Exposure B	Exposure C		Upwind of crest	Downwind of Crest
2-dimensional ridges (or valleys with negative H in $K_1/(H/L_h)$)	1.30	1.45	1.55	3	1.5	1.5
2-dimensional escarpments	0.75	0.85	0.95	2.5	1.5	4
3-dimensional axisym. Hill	0.95	1.05	1.15	4	1.5	1.5

Figure 6.2.4 Topographic factor, K_{zt} - Method 2

Enclosed, Partially Enclosed, and Open Buildings: Walls & Roofs		
Enclosure Classification	GC_{pi}	Notes: 1. Plus and minus signs signify pressures acting toward and away from the internal surfaces, respectively. 2. Values of GC_{pi} shall be used with q_z or q_h as specified in Sec 2.4.11. 3. Two cases shall be considered to determine the critical load requirements for the appropriate condition: (i) a positive value of GC_{pi} applied to all internal surfaces (ii) a negative value of GC_{pi} applied to all internal surfaces.
Open Building	0.00	
Partially Enclosed Building	+0.55 -0.55	
Enclosed Building	+0.18 -0.18	

Figure 6.2.5 Internal pressure coefficient, GC_{pi} main wind force resisting system component and cladding - Method 2 (All Heights)

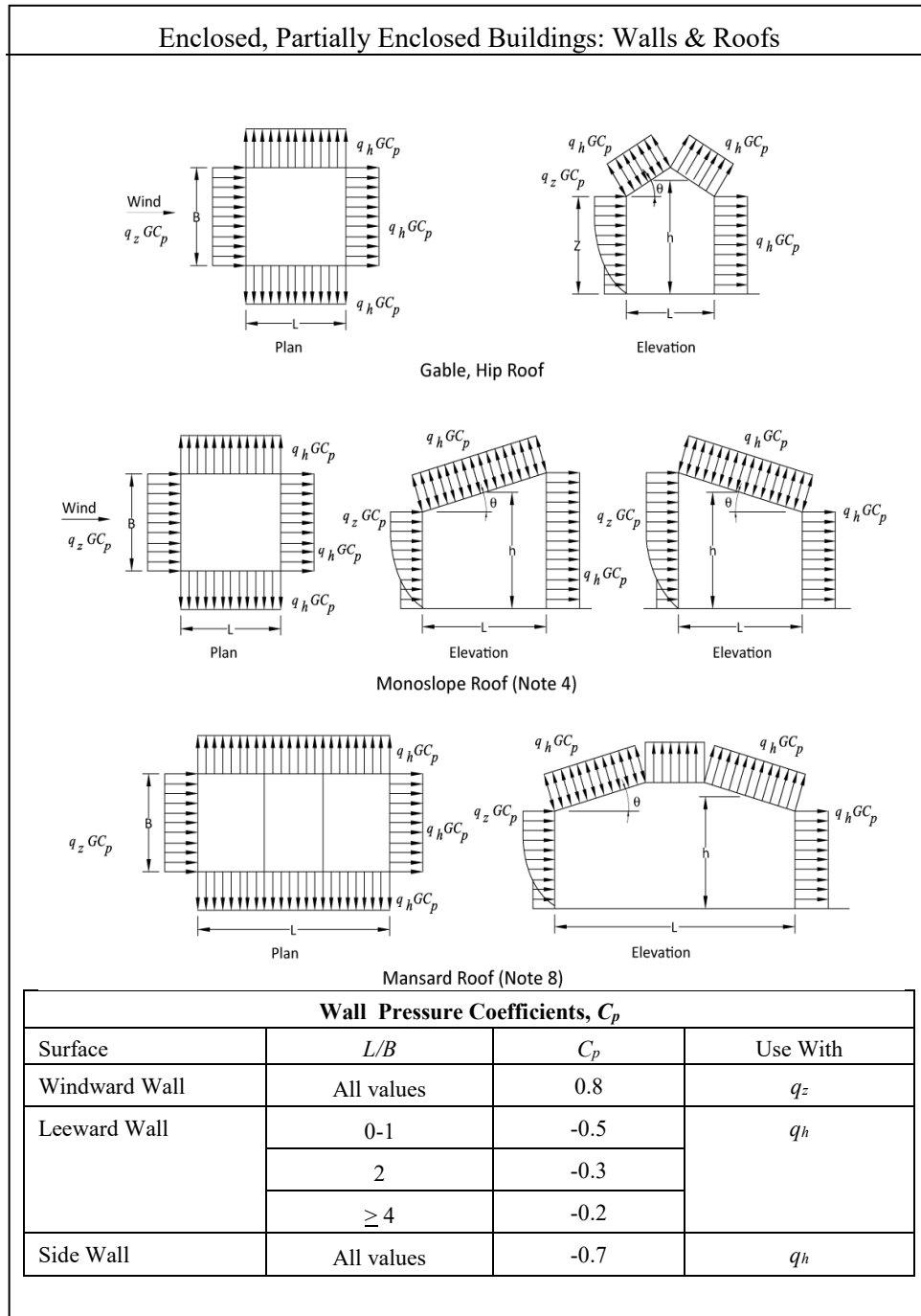


Figure 6.2.6 External Pressure Coefficients, C_p main wind force resisting system - Method 2 (All Heights)

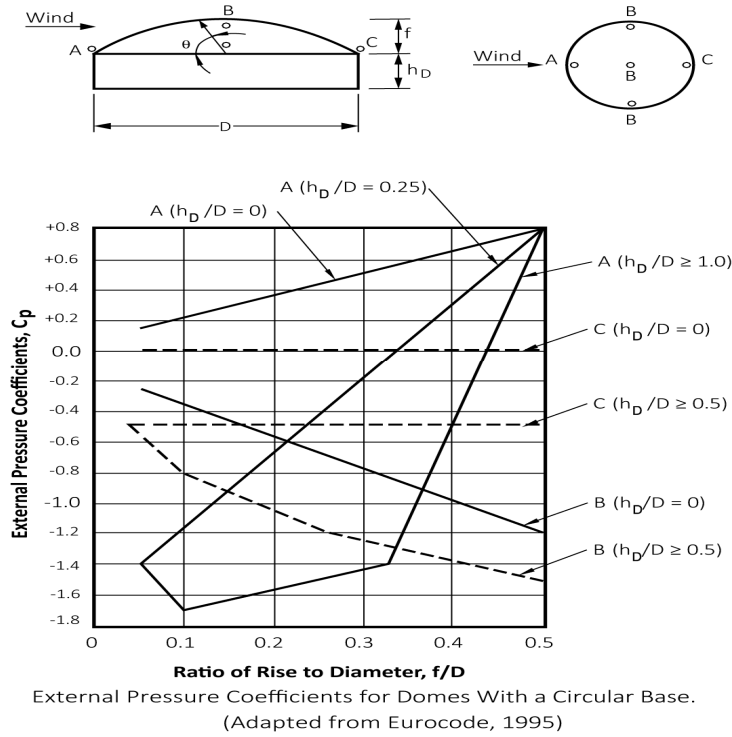
Roof Pressure Coefficients, C_p , for use with q_h												
Wind Direction	Windward									Leeward		
	Angle, θ (degrees)									Angle, θ (degrees)		
	h/L	10	15	20	25	30	35	45	$>60^\#$	10	15	>20
Normal To ridge for $\theta \geq 10^\circ$	≤ 0.25	-0.7 -0.18	-0.5 0.0*	-0.3 0.2	-0.2 0.3	-0.2 0.3	0.0* 0.4	0.4	0.010	-0.3	-0.5	-0.6
	0.5	-0.9 -0.18	-0.7 -0.18	-0.4 0.0*	-0.3 0.2	-0.2 0.2	-0.2 0.3	0.0* 0.4	0.010	-0.5	-0.5	-0.6
	≥ 1.0	-1.3** -0.18	-1.0 -0.18	-0.7 -0.18	-0.5 0.0*	-0.3 0.2	-0.2 0.2	0.0* 0.3	0.010	-0.7	-0.6	-0.6
Normal To ridge for $\theta < 10^\circ$ and Parallel to ridge for all θ	≤ 0.5	Horizontal distance from Windward edge		C_p		* Value is provided for interpolation purposes ** Value can be reduced linearly with area over which it is applicable as follows						
		0 to $h/2$		-0.9, -0.18								
		$h/2$ to h		-0.9, -0.18								
		h to $2h$		-0.5, -0.18								
	≥ 1.0	$> 2h$		-0.3, -0.18		Area (m^2)		Reduction Factor				
		0 to $h/2$		-1.3**, -0.18		≤ 9.3		1.0				
$> h/2$		-0.7, -0.18		23.2		0.9						
						≥ 92.9		0.8				

Notes:

1. Plus and minus signs signify pressures acting toward and away from the surfaces, respectively.
 2. Linear interpolation is permitted for values of L/B , h/L and θ other than shown. Interpolation shall only be carried out between values of the same sign. Where no value of the same sign is given, assume 0.0 for interpolation purposes.
 3. Where two values of C_p are listed, this indicates that the windward roof slope is subjected to either positive or negative pressures and the roof structure shall be designed for both conditions. Interpolation for intermediate ratios of h/L in this case shall only be carried out between C_p values of like sign.
 4. For monoslope roofs, entire roof surface is either a windward or leeward surface.
 5. For flexible buildings use appropriate G_f as determined by Sec 2.4.8.
 6. Refer to Figure 6.2.7 for domes and Figure 6.2.8 for arched roofs.
 7. Notation:
 - B : Horizontal dimension of building, in meter, measured normal to wind direction.
 - L : Horizontal dimension of building, in meter, measured parallel to wind direction.
 - h : Mean roof height in meters, except that eave height shall be used for e 10 degrees.
 - z : Height above ground, in meters.
 - G : Gust effect factor.
 - q_z, q_h : Velocity pressure, in N/m^2 , evaluated at respective height.
 - θ : Angle of plane of roof from horizontal, in degrees.
 8. For mansard roofs, the top horizontal surface and leeward inclined surface shall be treated as leeward surfaces from the table
 9. Except for MWFRS's at the roof consisting of moment resisting frames, the total horizontal shear shall not be less than that determined by neglecting wind forces on roof surfaces.
- [#]For roof slopes greater than 80° , use $C_p = 0.8$

Figure 6.2.6 (Contd.) External pressure coefficients, C_p main wind force resisting system - Method 2 (All Heights)

Enclosed, Partially Enclosed Buildings and Structures: Domed Roofs



Notes:

1. Two load cases shall be considered:
 Case A. C_p values between A and B and between B and C shall be determined by linear interpolation along arcs on the dome parallel to the wind direction;
 Case B. C_p shall be the constant value of A for $\theta \leq 25$ degrees, and shall be determined by linear interpolation from 25 degrees to B and from B to C.
2. Values denote C_p to be used with q_{h_D+f} where $(h_D + f)$ is the height at the top of the dome.
3. Plus and minus signs signify pressures acting toward and away from the surfaces, respectively.
4. C_p is constant on the dome surface for arcs of circles perpendicular to the wind direction; for example, the arc passing through B-B-B and all arcs parallel to B-B-B.
5. For values of h_D/D between those listed on the graph curves, linear interpolation shall be permitted.
6. $\theta=0$ degrees on dome springline, $\theta=90$ degrees at dome center top point. f is measured from springline to top.
7. The total horizontal shear shall not be less than that determined by neglecting wind forces roof surfaces.
8. For f/D values less than 0.05, use Figure 6.2.6.

Figure 6.2.7 External pressure coefficients, C_p main wind force resisting system - Method 2 (All Heights)

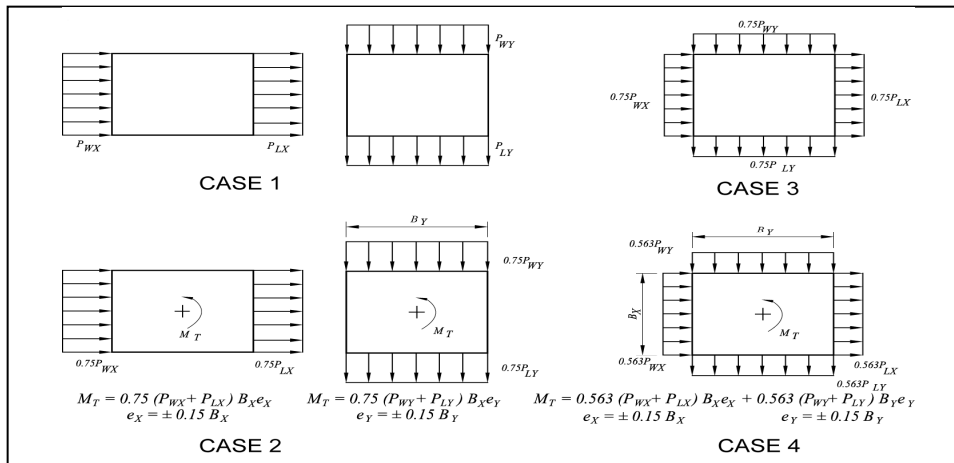
Enclosed, Partially Enclosed Buildings and Structures: Arched Roofs

Condition	Rise-to-span ratio, r	C_p		
		Windward quarter	Center half	Leeward quarter
Roof on elevated structure	$0 < r < 0.2$	-0.9	$-0.7 - r$	-0.5
	$0.2 \leq r < 0.3^*$	$1.5 r - 0.3$	$-0.7 - r$	-0.5
	$0.3 \leq r \leq 0.6$	$2.75 r - 0.7$	$-0.7 - r$	-0.5
Roof springing from ground level	$0 < r \leq 0.6$	$1.4 r$	$-0.7 - r$	-0.5

Notes:

- * When the rise-to-span ratio is $0.2 \leq r \leq 0.3$, alternate coefficients given by $(6r - 2.1)$ shall also be used for the windward quarter.
- 1. Values listed are for the determination of average load on main wind force resisting systems.
- 2. Plus and minus signs signify pressures acting toward and away from the surfaces, respectively.
- 3. For wind directed parallel to the axis of the arch, use pressure coefficients from Figure 6.2.6 with wind directed parallel to ridge.
- 4. For components and cladding: (1) At roof perimeter, use the external pressure coefficients in Figure 6.2.11 with e based on spring-line slope and (2) for remaining roof areas, use external pressure coefficients of this Table multiplied by 0.87.

Figure 6.2.8 External pressure coefficients, C_p main wind force resisting system component and cladding - Method 2 (All Heights)



Case 1.	Full design wind pressure acting on the projected area perpendicular to each principal axis of the structure, considered separately along each principal axis.
Case 2.	Three quarters of the design wind pressure acting on the projected area perpendicular to each principal axis of the structure in conjunction with a torsional moment as shown, considered separately for each principal axis.
Case 3.	Wind loading as defined in Case 1, but considered to act simultaneously at 75% of the specified value.
Case 4.	Wind loading as defined in Case 2, but considered to act simultaneously at 75% of the specified value.
Notes:	
1.	Design wind pressures for windward and leeward faces shall be determined in accordance with the provisions of Sec 2.4.11 as applicable for building of all heights.
2.	Diagrams show plan views of building.
3.	Notation:
	P_{wx}, P_{wy} : Windward face design pressure acting in the x, y principal axis, respectively.
	P_{Lx}, P_{Ly} : Leeward face design pressure acting in the x, y principal axis, respectively.
	$e(e_x, e_y)$: Eccentricity for the x, y principal axis of the structure, respectively.
	M_T : Torsional moment per unit height acting about a vertical axis of the building.

Figure 6.2.9 Design wind load cases for main wind force resisting system-Method 2 (All Heights)

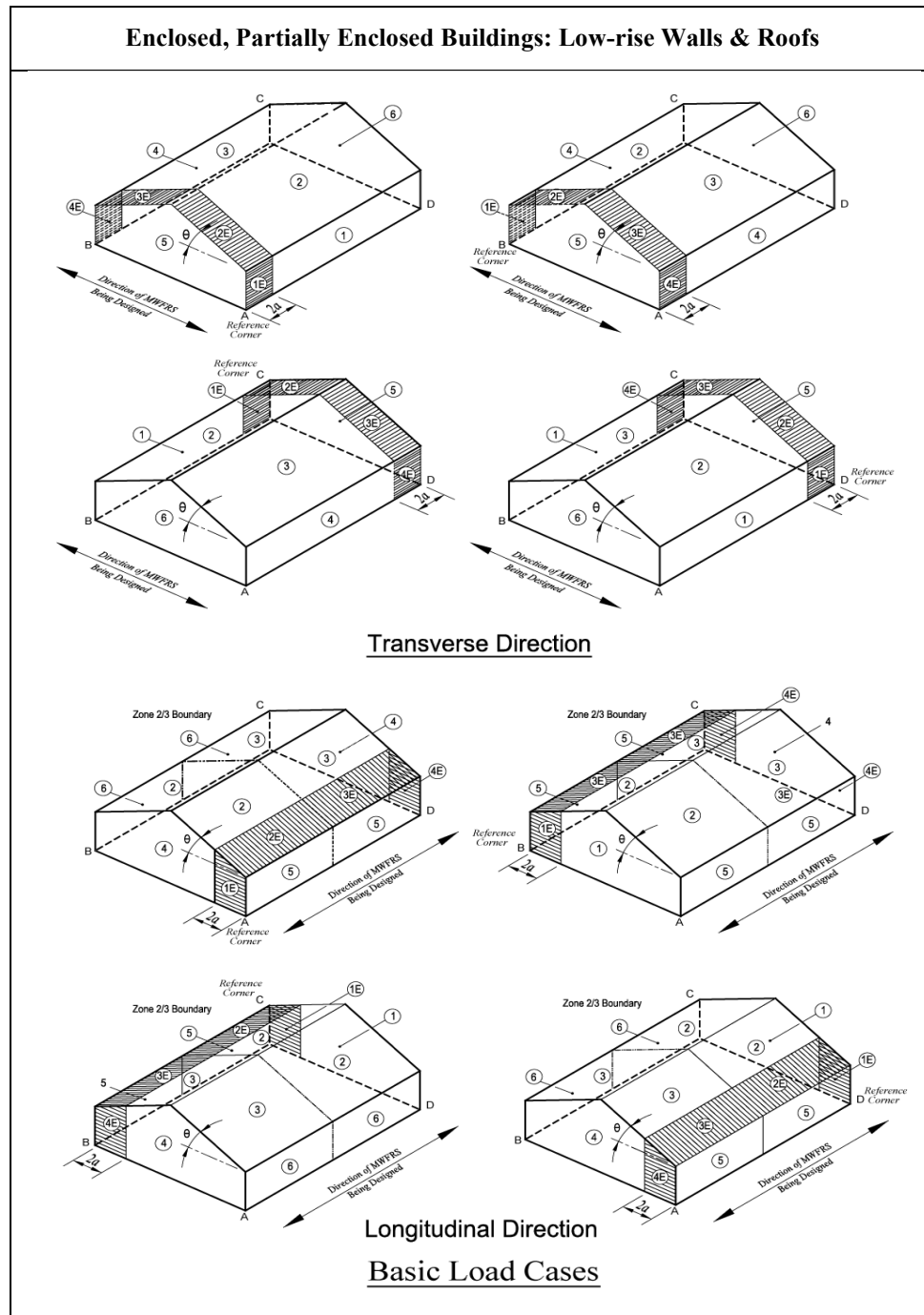


Figure 6.2.10 External pressure coefficients, GC_{pf} for main wind force resisting system- Method 2 ($h \leq 18.3$ m)

Enclosed, Partially Enclosed Buildings: Low-rise Walls & Roofs

Roof Angle θ (degrees)	Building Surface									
	1	2	3	4	5	6	1E	2E	3E	4E
0-5	0.40	-0.69	-0.37	-0.29	-0.45	-0.45	0.61	-1.07	-0.53	-0.43
20	0.53	-0.69	-0.48	-0.43	-0.45	-0.45	0.80	-1.07	-0.69	-0.64
30-45	0.56	0.21	-0.43	-0.37	-0.45	-0.45	0.69	0.27	-0.53	-0.48
90	0.56	0.56	-0.37	-0.37	-0.45	-0.45	0.69	0.69	-0.48	-0.48

Notes:

1. Plus and minus signs signify pressures acting toward and away from the surfaces, respectively.
2. For values of θ other than those shown, linear interpolation is permitted.
3. The building must be designed for all wind directions using the 8 loading patterns shown. The load patterns are applied to each building corner in turn as the Reference Corner.
4. Combinations of external and internal pressures (see Figure 6.2.5) shall be evaluated as required to obtain the most severe loadings.
5. For the torsional load cases shown below, the pressures in zones designated with a "T" (1T, 2T, 3T, 4T) shall be 25% of the full design wind pressures (zones 1, 2, 3, 4).
Exception: One story buildings with h less than or equal to 9.1m, buildings two stories or less framed with light frame construction, and buildings two stories or less designed with flexible diaphragms need not be designed for the torsional load cases.
Torsional loading shall apply to all eight basic load patterns using the figures below applied at each reference corner.
6. Except for moment-resisting frames, the total horizontal shear shall not be less than that determined by neglecting wind forces on roof surfaces.
7. For the design of the MWFRS providing lateral resistance in a direction parallel to a ridge line or for flat roofs, use $\theta = 0^\circ$ and locate the zone 2/3 boundary at the mid-length of the building.
8. The roof pressure coefficient GC_{pr} , when negative in Zone 2 or 2E, shall be applied in Zone 2/2E for a distance from the edge of roof equal to 0.5 times the horizontal dimension of the building parallel to the direction of the MWFRS being designed or 2.5 times the eave height, h_e , at the windward wall, whichever is less; the remainder of Zone 2/2E extending to the ridge line shall use the pressure coefficient GC_{pr} for Zone 3/3E.
9. Notation:
 a : 10 percent of least horizontal dimension or $0.4h$, whichever is smaller, but not less than either 4% of least horizontal dimension or 0.9 m.
 h : Mean roof height, in meters, except that eave height shall be used for $\theta \leq 10^\circ$.
 θ : Angle of plane of roof from horizontal, in degrees.

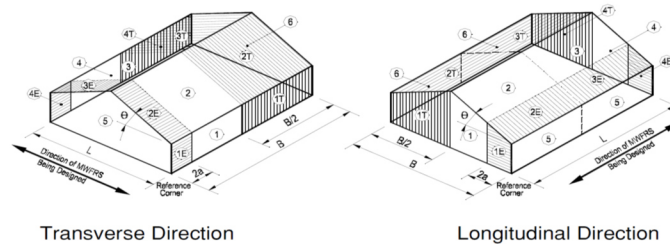
**Torsional Load Cases**

Figure 6.2.10 (Contd.) External pressure coefficients, GC_{pr} for main wind force resisting system - Method 2 ($h \leq 18.3$ m)

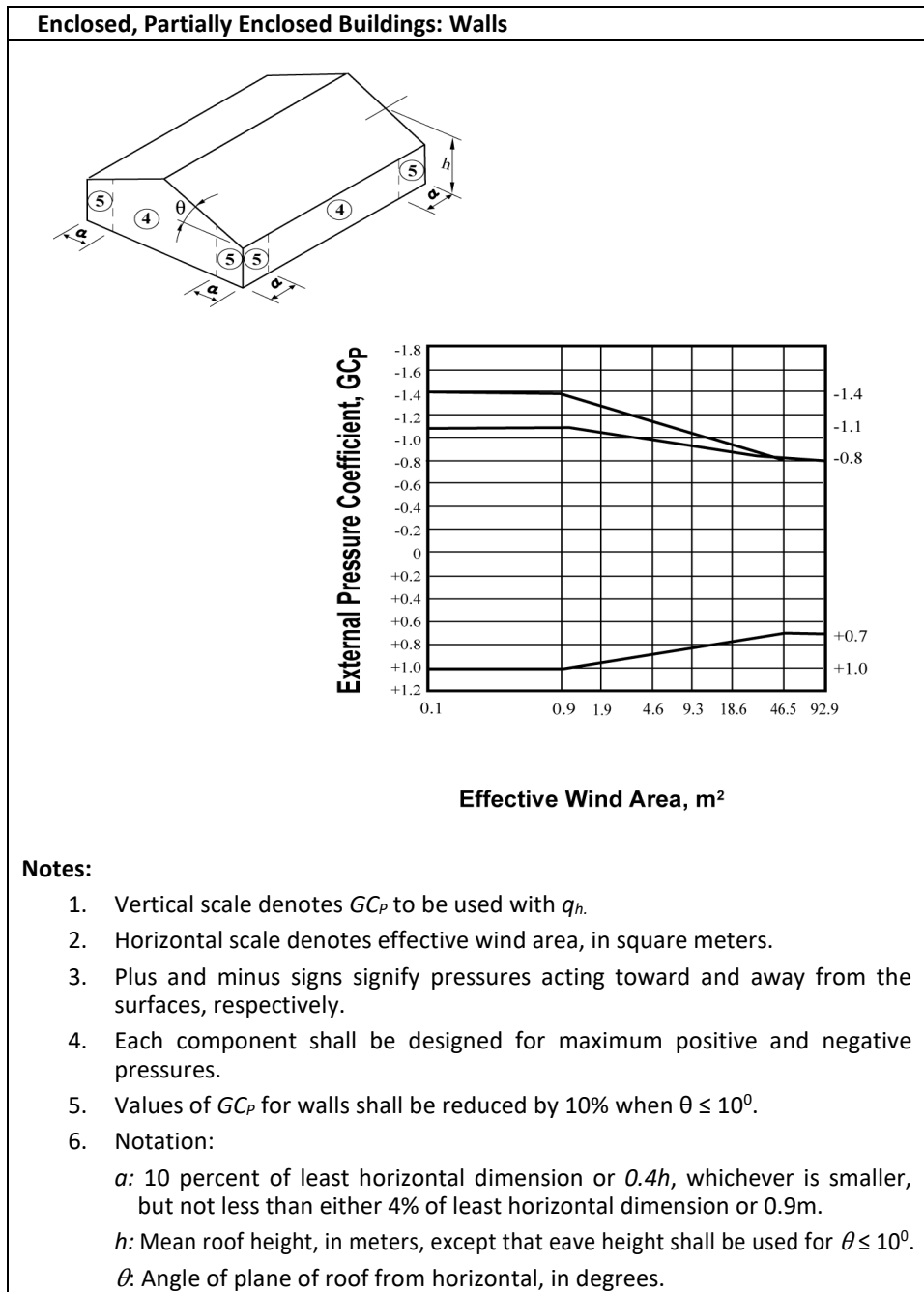


Figure 6.2.11(a) External pressure coefficients, GC_p for components and cladding—Method 2 ($h \leq 18.3$ m)

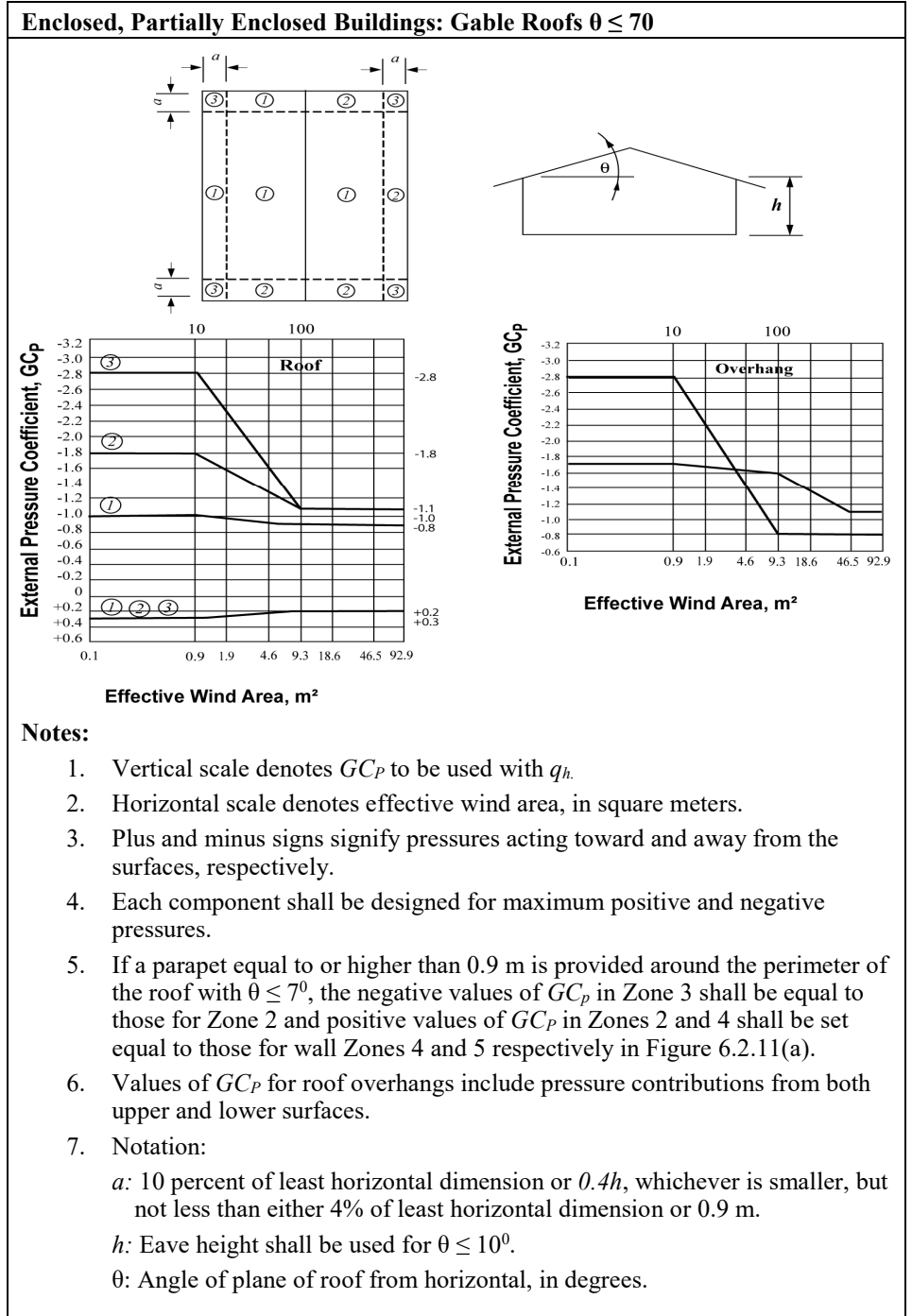


Figure 6.2.11(b) External pressure coefficients, G_{CP} for components and cladding—Method 2 ($h \leq 18.3$ m)

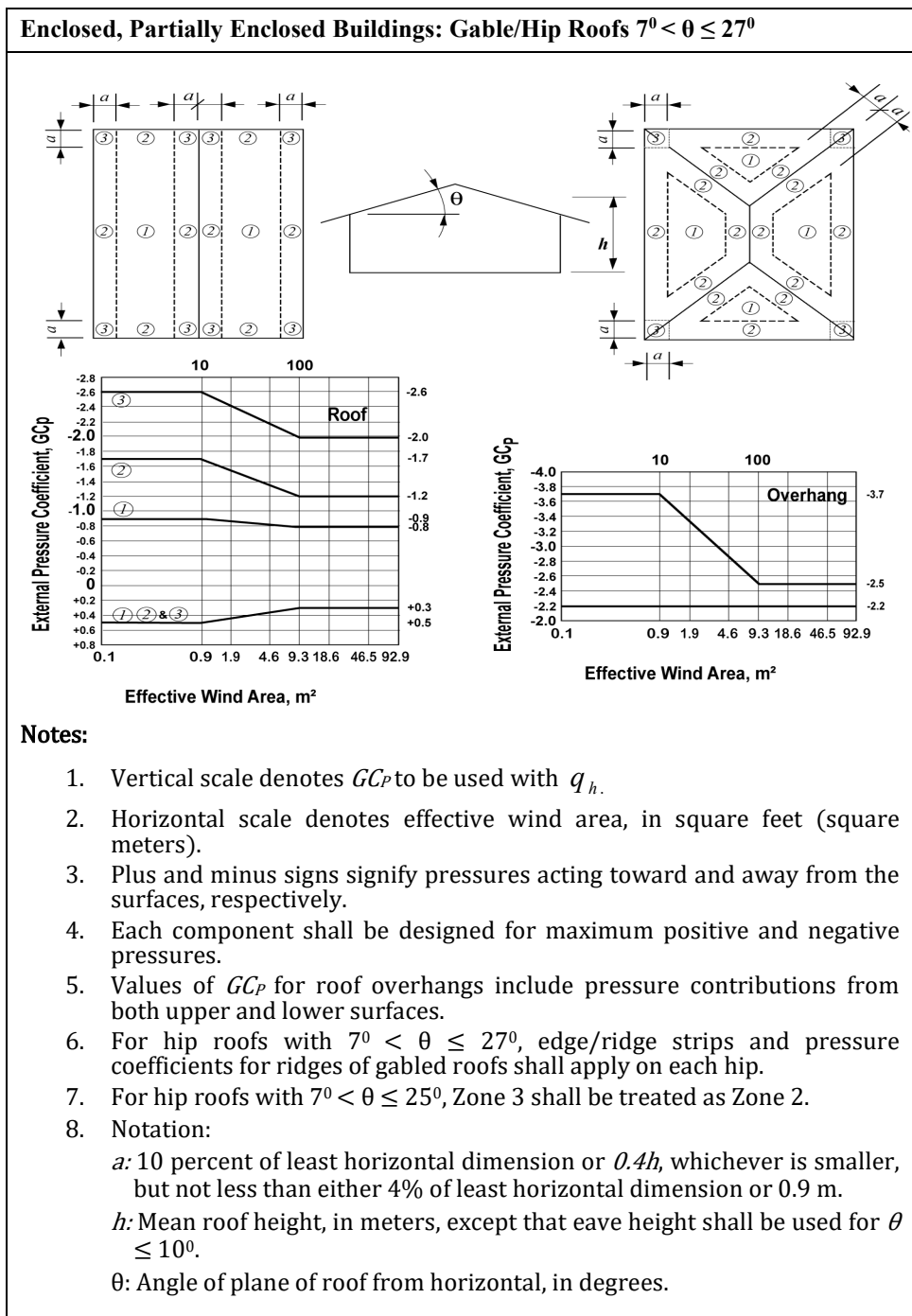


Figure 6.2.11(c) External pressure coefficients, GC_p for components and cladding—Method 2 ($h \leq 18.3$ m)

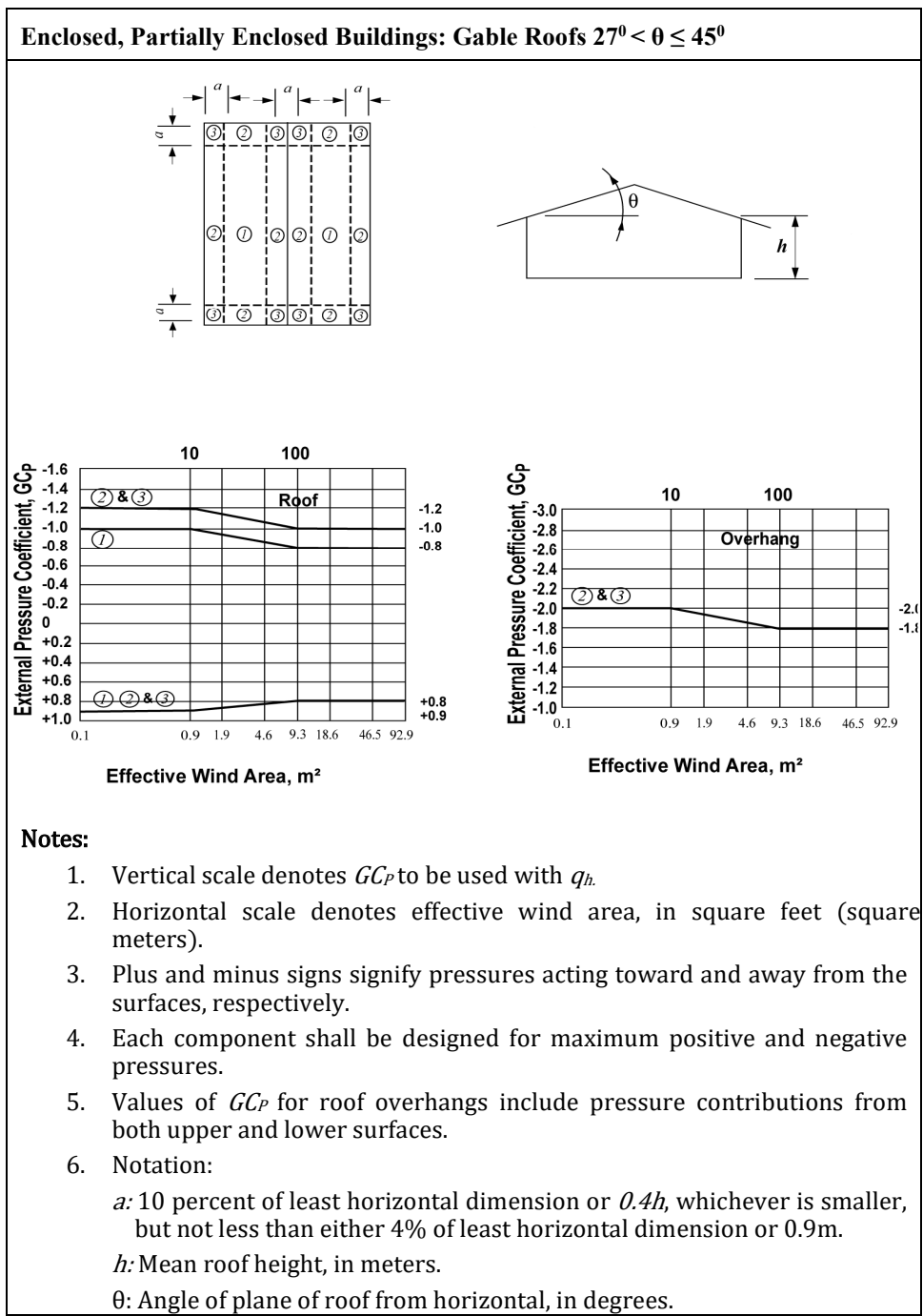


Figure 6.2.11(d) External pressure coefficients, GC_p for components and cladding—Method 2 ($h \leq 18.3$ m)

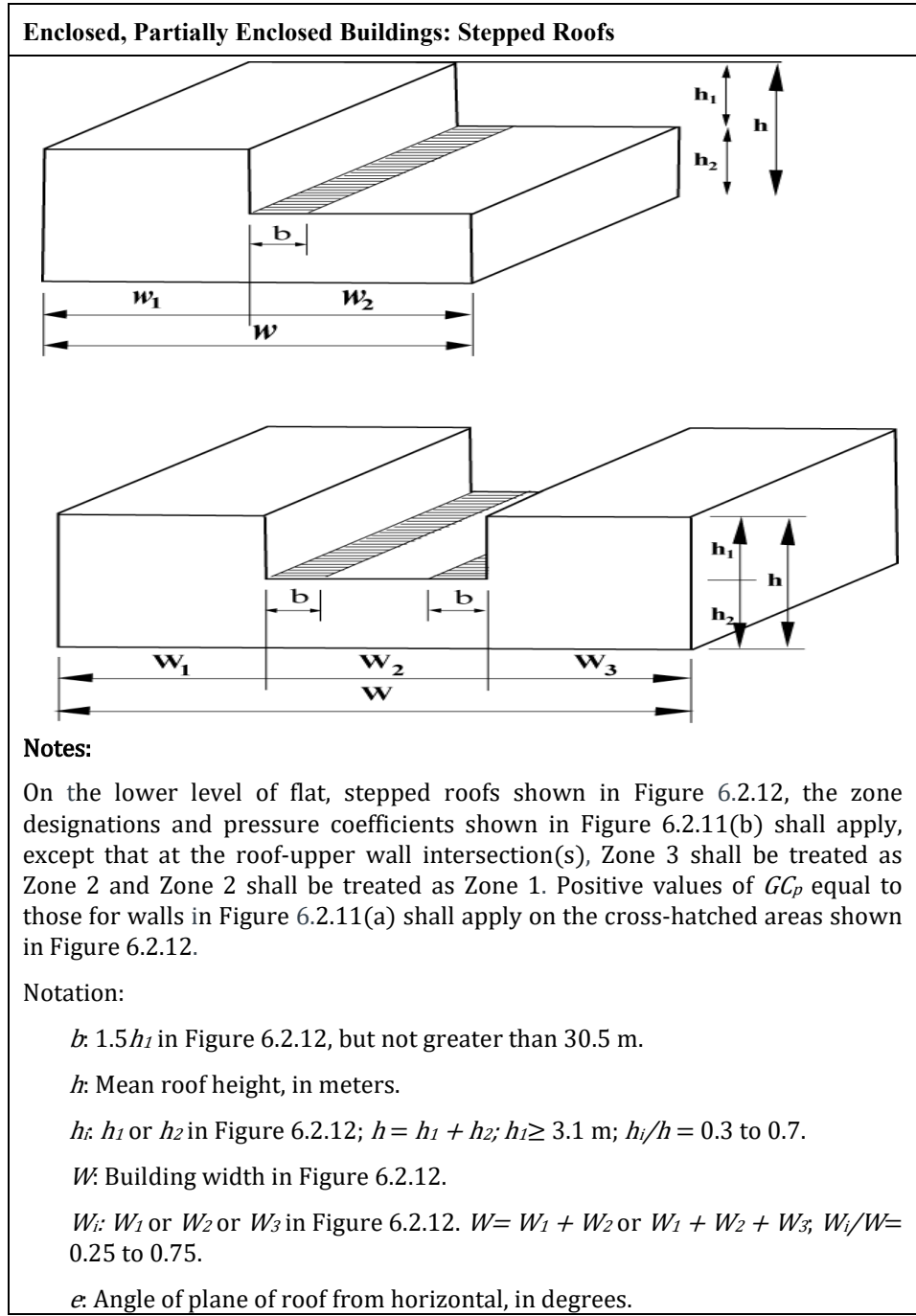


Figure 6.2.12 External pressure coefficients, GC_p for components and cladding—Method 2 ($h \leq 18.3$ m)

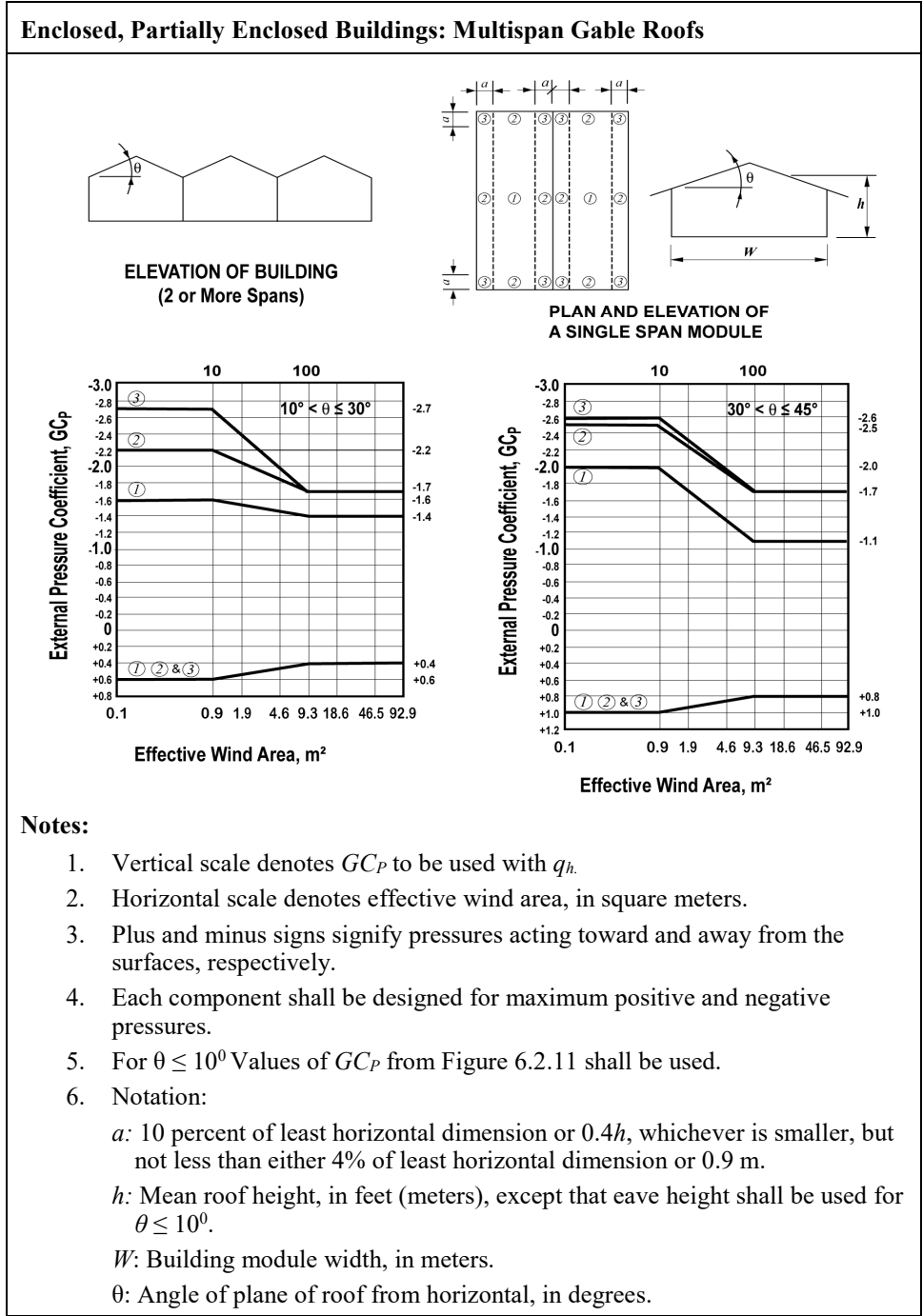
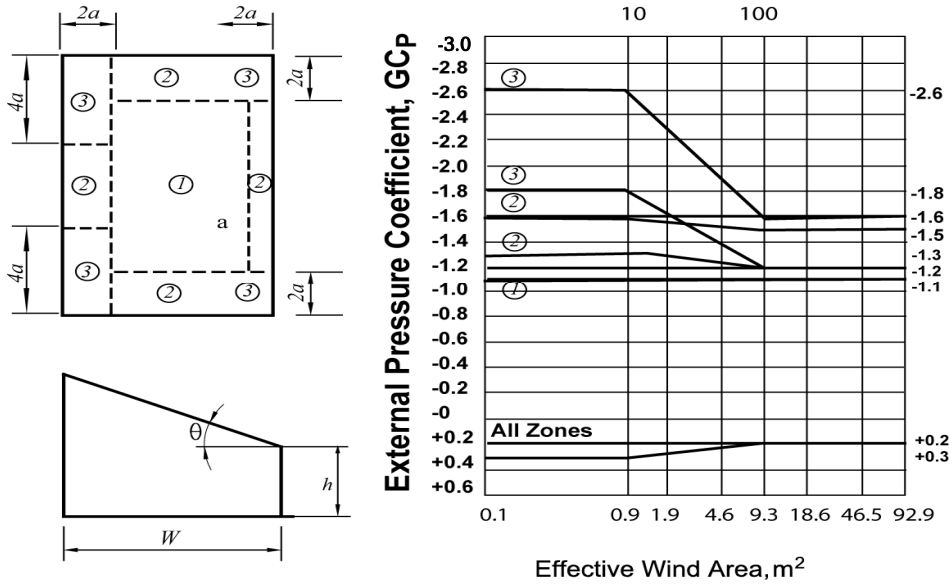


Figure 6.2.13 External pressure coefficients, GC_p for components and cladding—Method 2 ($h \leq 18.3$ m)

Enclosed, Partially Enclosed Buildings: Monoslope Roofs $3^\circ < \theta \leq 10^\circ$



Notes:

1. Vertical scale denotes GCP to be used with q_h .
2. Horizontal scale denotes effective wind area A , in square meters.
3. Plus and minus signs signify pressures acting toward and away from the surfaces, respectively.
4. Each component shall be designed for maximum positive and negative pressures.
5. For $\theta \leq 30^\circ$ Values of GCP from Figure 6.2.11(b) shall be used.
6. Notation:
 - a : 10 percent of least horizontal dimension or $0.4h$, whichever is smaller, but not less than either 4% of least horizontal dimension or 0.9 m.
 - h : Eave height shall be used for $\theta \leq 10^\circ$.
 - W : Building width, in meters.
 - θ : Angle of plane of roof from horizontal, in degrees.

Figure 6.2.14(a) External pressure coefficients, GCP for components and cladding—Method 2 ($h \leq 18.3$ m)

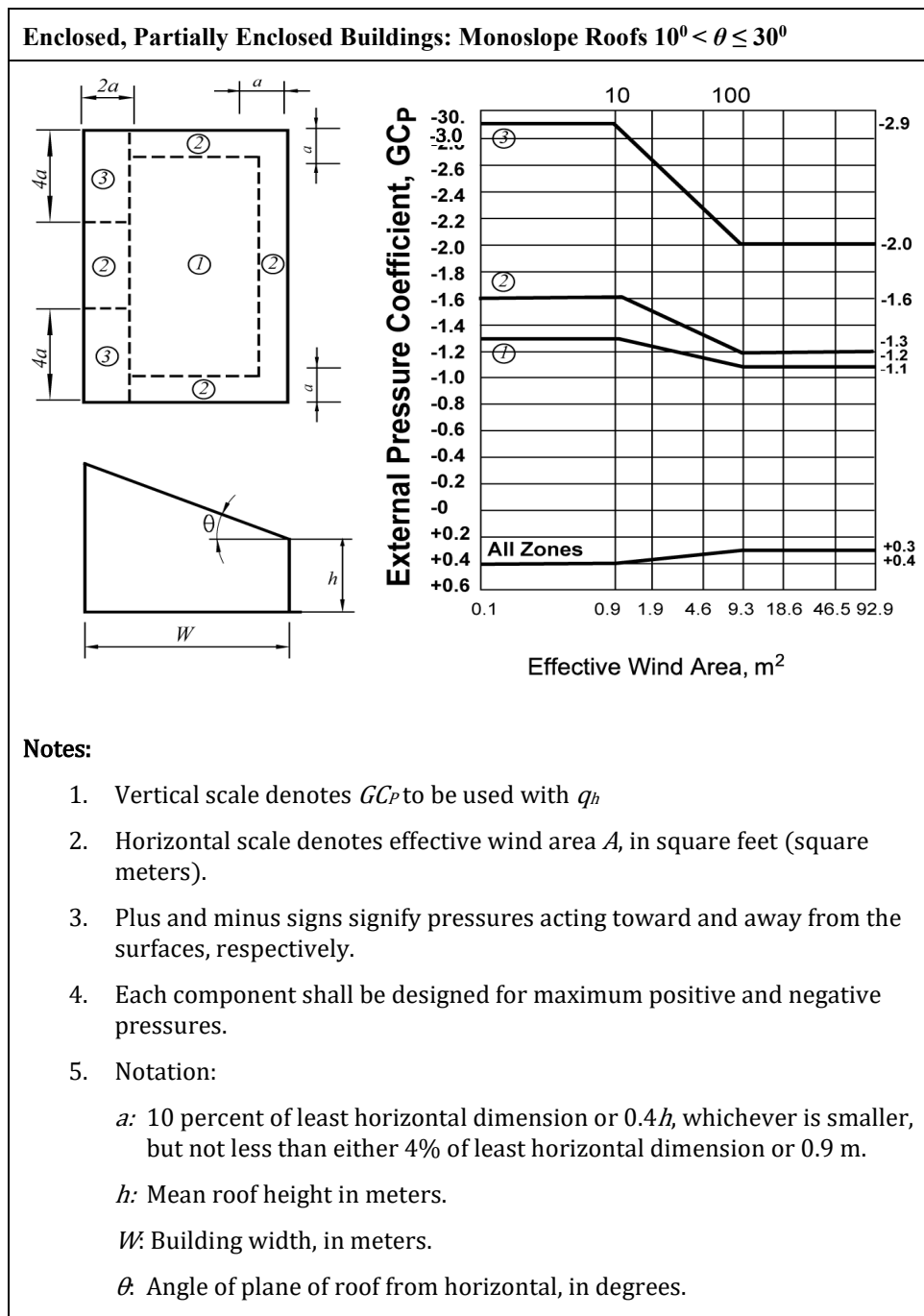


Figure 6.2.14(b) External pressure coefficients, G_{Cp} for components and cladding—Method 2 ($h \leq 18.3$ m)

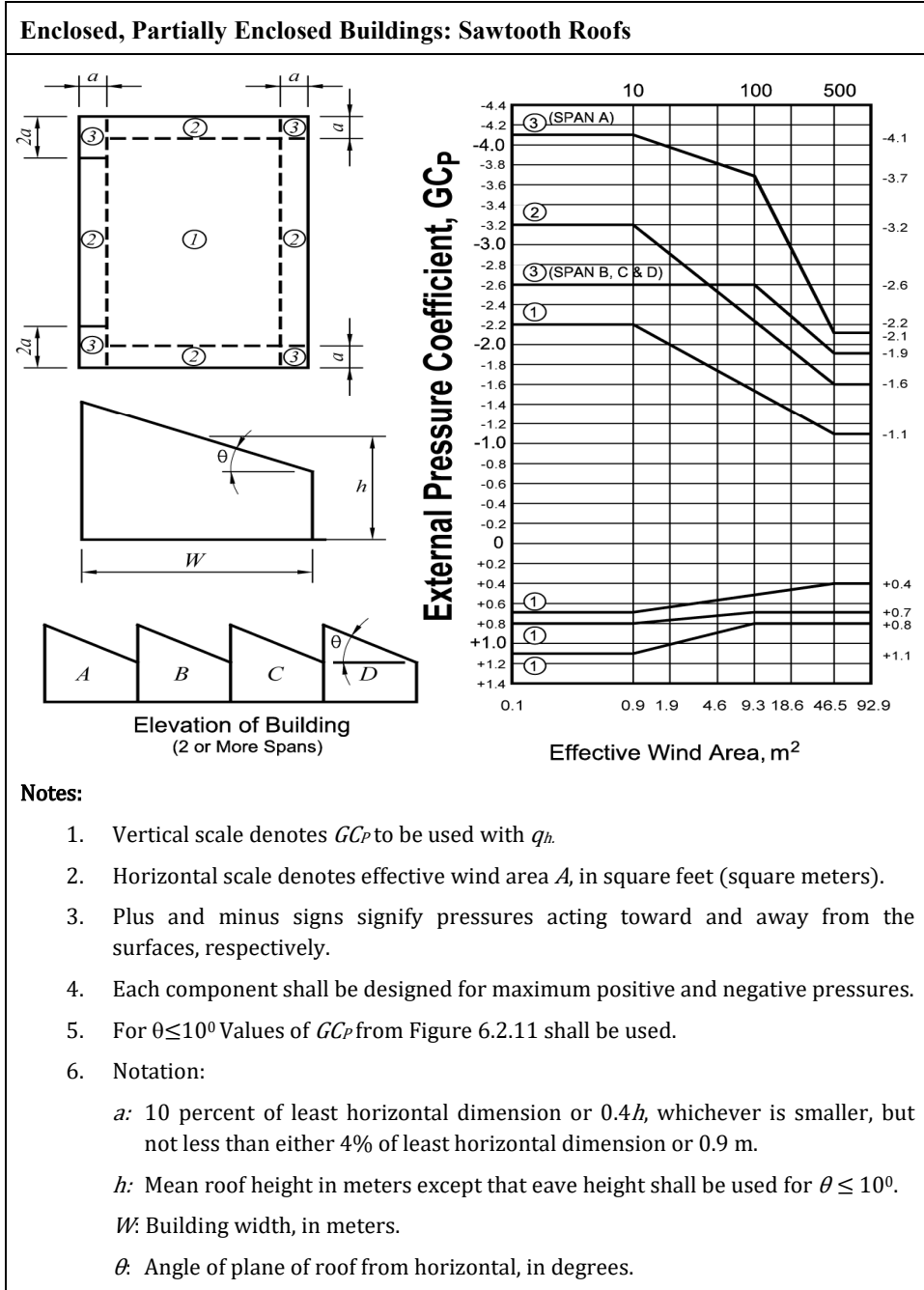


Figure 6.2.15 External pressure coefficients, GC_p for components and cladding—Method 2 ($h \leq 18.3$ m)

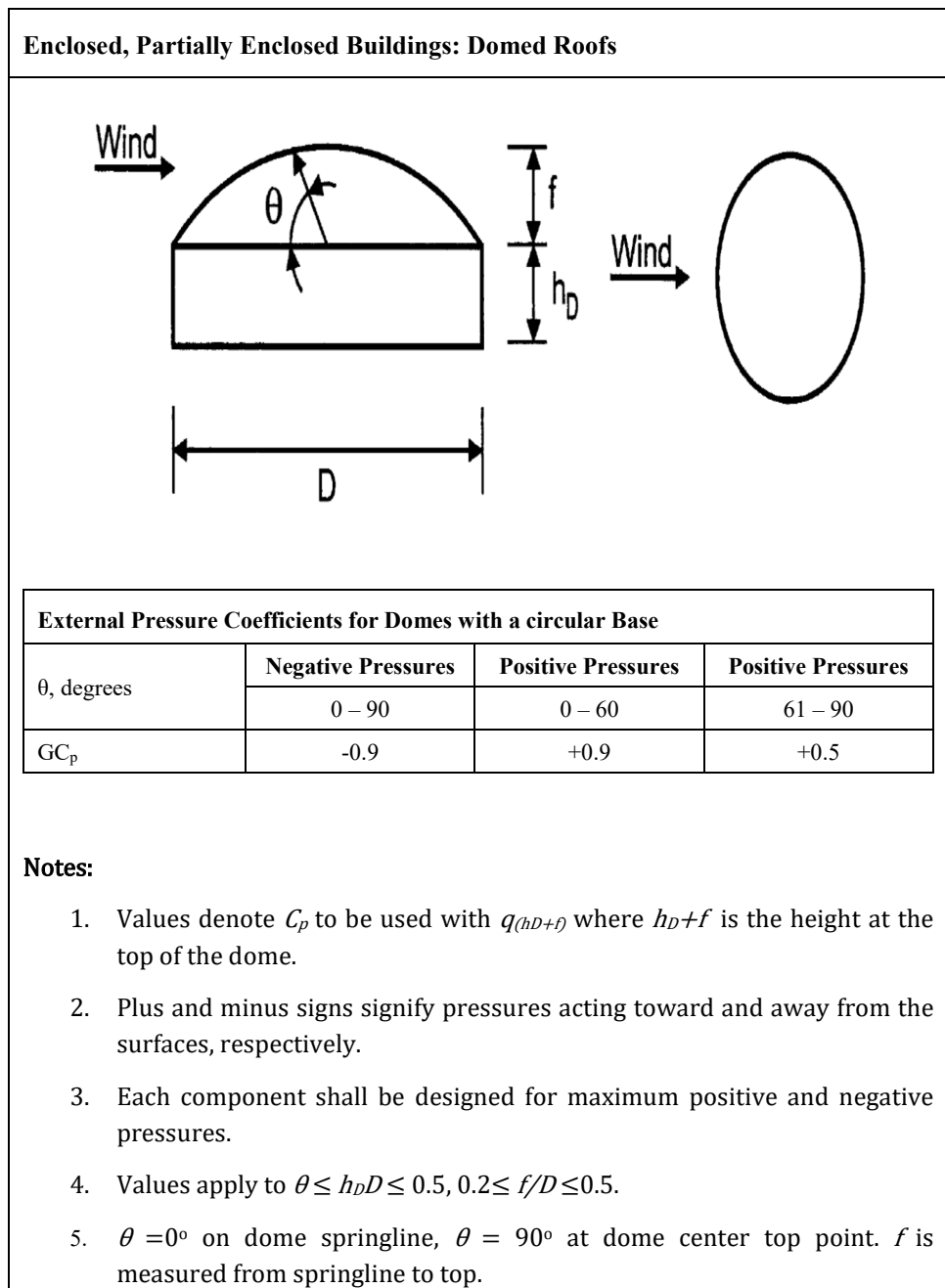
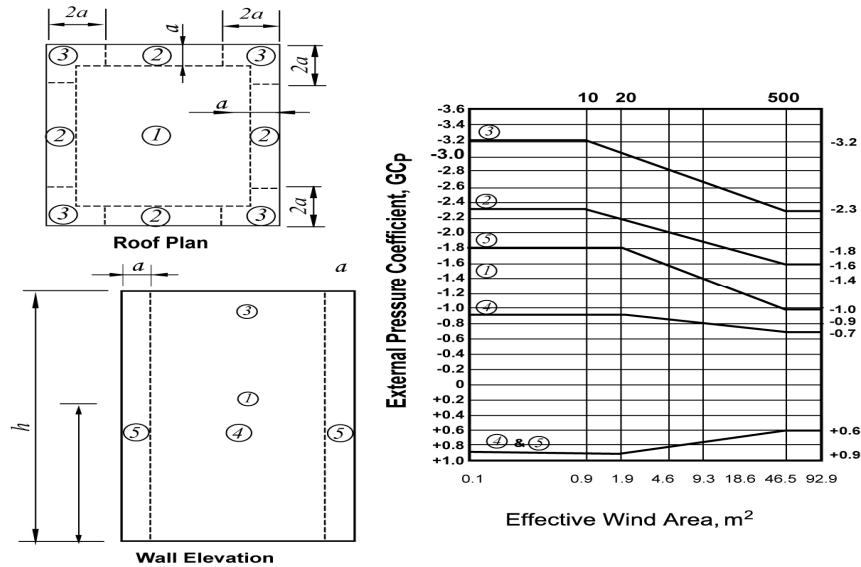


Figure 6.2.16 External pressure coefficients, G_{Cp} for components and cladding – Method 2 (All heights)

Enclosed, Partially Enclosed Buildings: Walls & Roofs



Notes:

1. Vertical scale denotes GC_p to be used with appropriate q_z or q_h .
2. Horizontal scale denotes effective wind area A , in square feet (square meters).
3. Plus and minus signs signify pressures acting toward and away from the surfaces, respectively.
4. Use q_z with positive values of GC_p and q_h with negative values of GC_p .
5. Each component shall be designed for maximum positive and negative pressures.
6. Coefficients are for roofs with angle $\theta \leq 10^\circ$. For other roof angles and geometry, use GC_p values from Figure 6.2.11 and attendant q_h based on exposure defined in Sec 2.4.6.
7. If a parapet equal to or higher than 0.9 m is provided around the perimeter of the roof with $\theta \leq 10^\circ$ Zone 3 shall be treated as Zone 2.
8. Notation:
 - a : 10 percent of least horizontal dimension, but not less than 0.9 m.
 - h : Mean roof height, in meters, except that eave height shall be used for $\theta \leq 10^\circ$.
 - z : height above ground, in (meters).
 - θ : Angle of plane of roof from horizontal, in degrees.

Figure 6.2.17 External pressure coefficients, GC_p for components and cladding – Method 2 ($h \leq 18.3$ m)

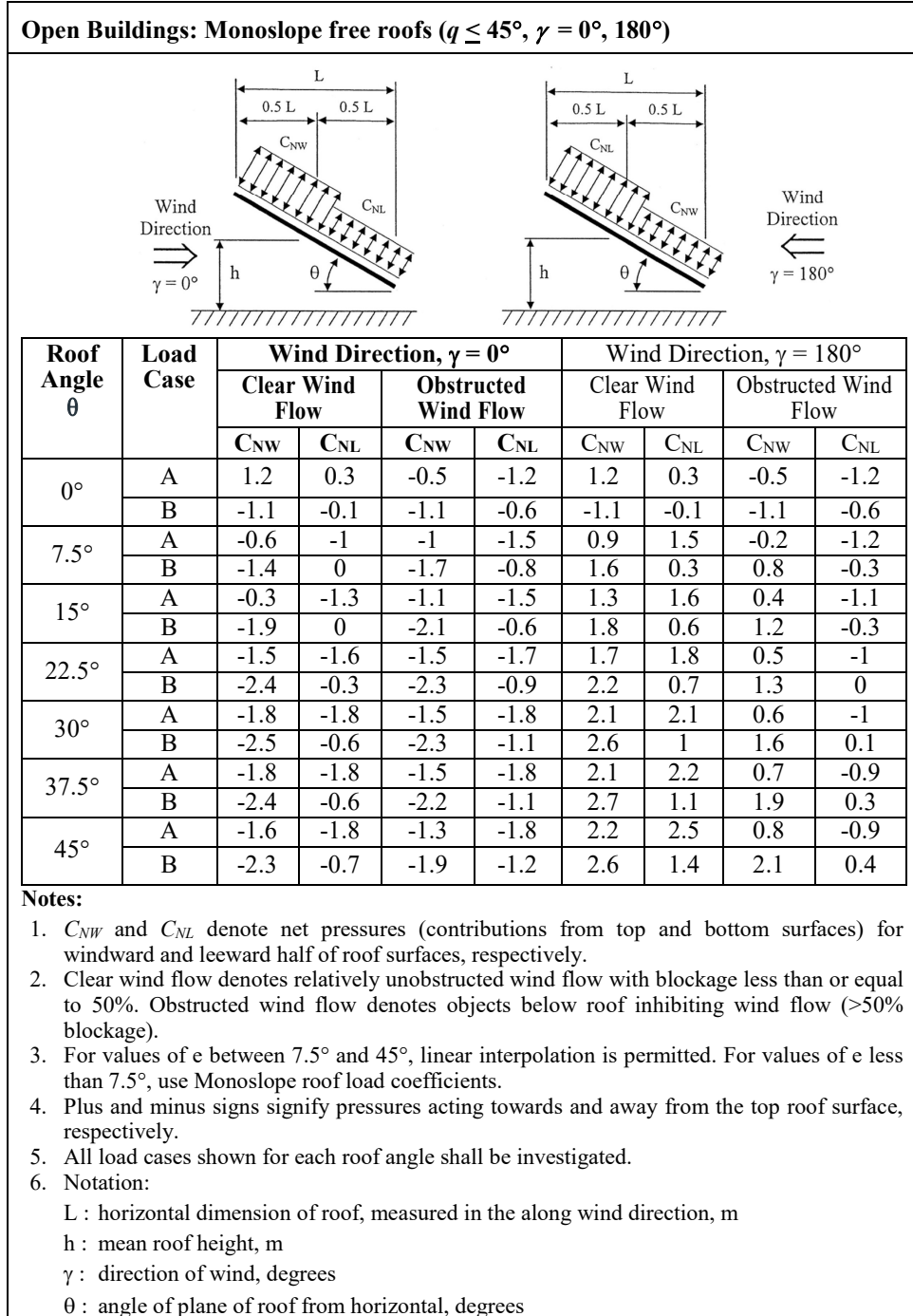
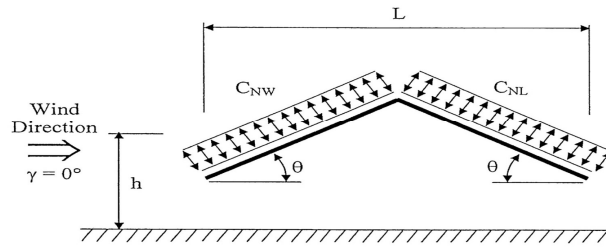


Figure 6.2.18(a) Net pressure coefficient, C_N for main wind force resisting system ($0.25 \leq h/L \leq 1.0$)

Open Buildings: Pitched Free Roofs ($\theta \leq 45^\circ, \gamma = 0^\circ, 180^\circ$)



Roof Angle, θ	Load Case	Wind Direction, $\gamma = 0^\circ, 180^\circ$			
		Clear Wind Flow		Obstructed Wind Flow	
		C_{NW}	C_{NL}	C_{NW}	C_{NL}
7.5°	A	1.1	-0.3	-1.6	-1
	B	0.2	-1.2	-0.9	-1.7
15°	A	1.1	-0.4	-1.2	-1
	B	0.1	-1.1	-0.6	-1.6
22.5°	A	1.1	0.1	-1.2	-1.2
	B	-0.1	-0.8	-0.8	-1.7
30°	A	1.3	0.3	-0.7	-0.7
	B	-0.1	-0.9	-0.2	-1.1
37.5°	A	1.3	0.6	-0.6	-0.6
	B	-0.2	-0.6	-0.3	-0.9
45°	A	1.1	0.9	-0.5	-0.5
	B	-0.3	-0.5	-0.3	-0.7

Notes:

1. C_{NW} and C_{NL} denote net pressures (contributions from top and bottom surfaces) for windward and leeward half of roof surfaces, respectively.
2. Clear wind flow denotes relatively unobstructed wind flow with blockage less than or equal to 50%. Obstructed wind flow denotes objects below roof inhibiting wind flow (>50% blockage).
3. For values of θ between 7.5° and 45°, linear interpolation is permitted. For values of θ less than 7.5°, use monoslope roof load coefficients.
4. Plus and minus signs signify pressures acting towards and away from the top roof surface, respectively.
5. All load cases shown for each roof angle shall be investigated.
6. Notation:
 L : horizontal dimension of roof, measured in the along wind direction, m
 h : mean roof height, m
 γ : direction of wind, degrees
 θ : angle of plane of roof from horizontal, degrees

Figure 6.2.18(b) Net pressure coefficient, C_N for main wind force resisting system ($0.25 \leq h/L \leq 1.0$)

Open Buildings: Troughed Free Roofs ($\theta \leq 45^\circ$, $\gamma = 0^\circ, 180^\circ$)					
Roof Angle, θ	Load Case	Wind Direction, $\gamma=0^\circ, 180^\circ$			
		Clear Wind Flow		Obstructed Wind Flow	
		C_{NW}	C_{NL}	C_{NW}	C_{NL}
7.5°	A	-1.1	0.3	-1.6	-0.5
	B	-0.2	1.2	-0.9	-0.8
15°	A	-1.1	0.4	-1.2	-0.5
	B	0.1	1.1	-0.6	-0.8
22.5°	A	-1.1	-0.1	-1.2	-0.6
	B	-0.1	0.8	-0.8	-0.8
30°	A	-1.3	-0.3	-1.4	-0.4
	B	-0.1	0.9	-0.2	-0.5
37.5°	A	-1.3	-0.6	-1.4	-0.3
	B	0.2	0.6	-0.3	-0.4
45°	A	-1.1	-0.9	-1.2	-0.3
	B	0.3	0.5	-0.3	-0.4

Notes:

- C_{NW} and C_{NL} denote net pressures (contributions from top and bottom surfaces) for windward and leeward half of roof surfaces, respectively.
- Clear wind flow denotes relatively unobstructed wind flow with blockage less than or equal to 50%. Obstructed wind flow denotes objects below roof inhibiting wind flow (>50% blockage).
- For values of θ between 7.5° and 45°, linear interpolation is permitted. For values of θ less than 7.5°, use monoslope roof load coefficients.
- Plus and minus signs signify pressures acting towards and away from the top roof surface, respectively.
- All load cases shown for each roof angle shall be investigated.
- Notation:
 - L : horizontal dimension of roof, measured in the along wind direction, m
 - h : mean roof height, m
 - γ : direction of wind, degrees
 - θ : angle of plane of roof from horizontal, degrees

Figure 6.2.18(c) Net pressure coefficient, C_N for main wind force resisting system ($0.25 \leq h/L \leq 1.0$)

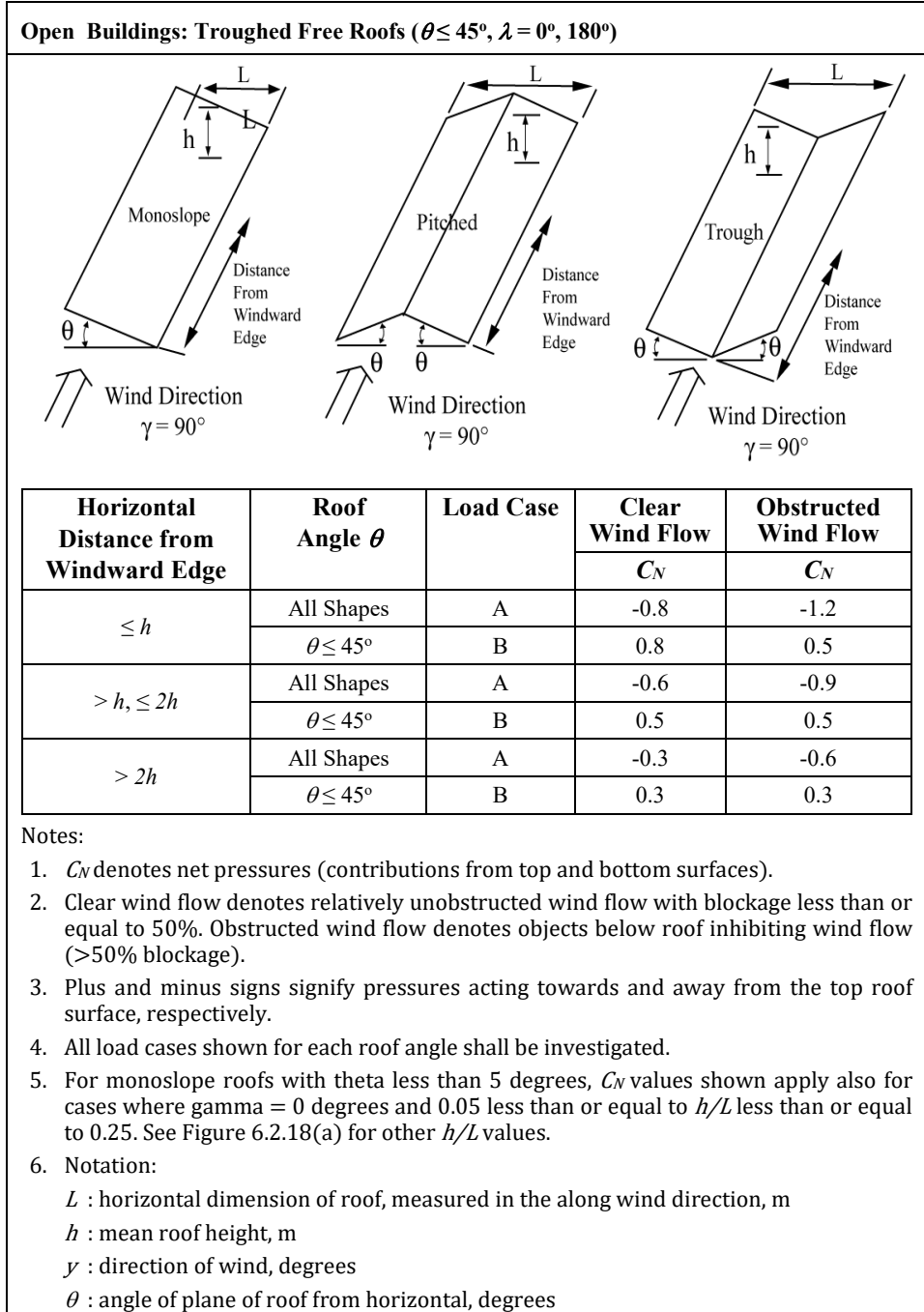
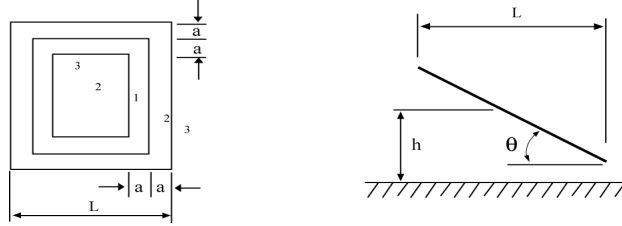


Figure 6.2.18(d) Net pressure coefficient, C_N for main wind force resisting system ($0.25 \leq h/L \leq 1.0$)

Open Buildings: Monoslope Free Roofs ($\theta \leq 45^\circ$)



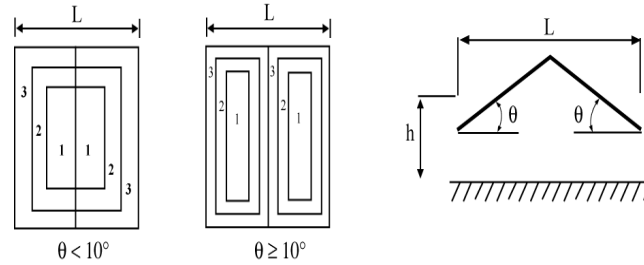
Roof Angle θ	Effective Wind Area	C_N											
		Clear Wind Flow						Obstructed Wind Flow					
		Zone 3		Zone 2		Zone 1		Zone 3		Zone 2		Zone 1	
0°	$\leq a^2$	2.4	-3.3	1.8	-1.7	1.2	-1.1	1	-3.6	0.8	-1.8	0.5	-1.2
	$>a^2, \leq 4.0a^2$	1.8	-1.7	1.8	-1.7	1.2	-1.1	0.8	-1.8	0.8	-1.8	0.5	-1.2
	$>4.0a^2$	1.2	-1.1	1.2	-1.1	1.2	-1.1	0.5	-1.2	0.5	-1.2	0.5	-1.2
7.5°	$\leq a^2$	3.2	-4.2	2.4	-2.1	1.6	-1.4	1.6	-5.1	0.5	-2.6	0.8	-1.7
	$>a^2, \leq 4.0a^2$	2.4	-2.1	2.4	-2.1	1.6	-1.4	1.2	-2.6	1.2	-2.6	0.8	-1.7
	$>4.0a^2$	1.6	-1.4	1.6	-1.4	1.6	-1.4	0.8	-1.7	0.8	-1.7	0.8	-1.7
15°	$\leq a^2$	3.6	-3.8	2.7	-2.9	1.8	-1.9	2.4	-4.2	1.8	-3.2	1.2	-2.1
	$>a^2, \leq 4.0a^2$	2.7	-2.9	2.7	-2.9	1.8	-1.9	1.8	-3.2	1.8	-3.2	1.2	-2.1
	$>4.0a^2$	1.8	-1.9	1.8	-1.9	1.8	-1.9	1.2	-2.1	1.2	-2.1	1.2	-2.3
30°	$\leq a^2$	5.2	-5	3.9	-3.8	2.6	-2.5	3.2	-4.6	2.4	-3.5	1.6	-2.3
	$>a^2, \leq 4.0a^2$	3.9	-3.8	3.9	-3.8	2.6	-2.5	2.4	-3.5	2.4	-3.5	1.6	-2.3
	$>4.0a^2$	2.6	-2.5	2.6	-2.5	2.6	-2.5	1.6	-2.3	1.6	-2.3	1.6	-2.3
45°	$\leq a^2$	5.2	-4.6	3.9	-3.5	2.6	-2.3	4.2	-3.8	3.2	-2.9	2.1	-1.9
	$>a^2, \leq 4.0a^2$	3.9	-3.5	3.9	-3.5	2.6	-2.3	3.2	-2.9	3.2	-2.9	2.1	-1.9
	$>4.0a^2$	2.6	-2.3	2.6	-2.3	2.6	-2.3	2.1	-1.9	2.1	-1.9	2.1	-1.9

Notes:

- C_N denotes net pressures (contributions from top and bottom surfaces).
- Clear wind flow denotes relatively unobstructed wind flow with blockage less than or equal to 50% wind flow denotes objects below roof inhibiting wind flow (>50% blockage).
- For values of e other than those shown, linear interpolation is permitted.
- Plus and minus signs signify pressures acting towards and away from the top roof surface, respectively.
- Components and cladding elements shall be designed for positive and negative pressure coefficients shown.
- Notation:
 - α : 10% of least horizontal dimension or $0.4h$, whichever is smaller but not less than 4% of least horizontal dimension or 0.9 m
 - h : mean roof height, m
 - L : horizontal dimension of building, measured in along wind direction, m
 - θ : angle of plane of roof from horizontal, degrees

Figure 6.2.19(a) Net pressure coefficient, C_N for components and cladding ($0.25 \leq h/L \leq 1.0$)

Open Buildings: Monoslope Free Roofs ($\theta \leq 45^\circ$)



Roof Angle θ	Effective Wind Area	C_N											
		Clear Wind Flow					Obstructed Wind Flow						
		Zone 3		Zone 2		Zone 1	Zone 3		Zone 2		Zone 1		
0°	$\leq a^2$	2.4	-3.3	1.8	-1.7	1.2	-1.1	1	-3.6	0.8	-1.8	0.5	-1.2
	$> a^2, \leq 4.0a^2$	1.8	-1.7	1.8	-1.7	1.2	-1.1	0.8	-1.8	0.8	-1.8	0.5	-1.2
	$> 4.0a^2$	1.2	-1.1	1.2	-1.1	1.2	-1.1	0.5	-1.2	0.5	-1.2	0.5	-1.2
7.5°	$\leq a^2$	2.2	-3.6	1.7	-1.8	1.1	-1.2	1	-5.1	0.8	-2.6	0.5	-1.7
	$> a^2, \leq 4.0a^2$	1.7	-1.8	1.7	-1.8	1.1	-1.2	0.8	-2.6	0.8	-2.6	0.5	-1.7
	$> 4.0a^2$	1.1	-1.2	1.1	-1.2	1.1	-1.2	0.5	-1.7	0.5	-1.7	as	-1.7
15°	$\leq a^2$	2.2	-2.2	1.7	-1.7	1.1	-1.1	1	-3.2	0.8	-2.4	0.5	-1.6
	$> a^2, \leq 4.0a^2$	1.7	-1.7	1.7	-1.7	1.1	-1.1	0.8	-2.4	0.8	-2.4	0.5	-1.6
	$> 4.0a^2$	1.1	-1.1	1.1	-1.1	1.1	-1.1	0.5	-1.6	0.5	-1.6	0.5	-1.6
30°	$\leq a^2$	2.6	-1.8	2	-1.4	1.3	-0.9	1	-2.4	0.8	-1.8	0.5	-1.2
	$> a^2, \leq 4.0a^2$	2	-1.4	2	-1.4	1.3	-0.9	0.8	-1.8	0.8	-1.8	0.5	-1.2
	$> 4.0a^2$	1.3	-0.9	1.3	-0.9	1.3	-0.9	0.5	-1.2	0.5	-1.2	0.5	-1.2
45°	$\leq a^2$	2.2	-1.6	1.7	-1.2	1.1	-0.8	1	-2.4	0.8	-1.8	0.5	-1.2
	$> a^2, \leq 4.0a^2$	1.7	-1.2	1.7	-1.2	1.1	-0.8	0.8	-1.8	0.8	-1.8	0.5	-1.2
	$> 4.0a^2$	1.1	-0.8	1.1	-0.8	1.1	-0.8	0.5	-1.2	0.5	-1.2	0.5	-1.2

Notes:

- C_N denotes net pressures (contributions from top and bottom surfaces).
- Clear wind flow denotes relatively unobstructed wind flow with blockage less than or equal to 50%. Obstructed wind flow denotes objects below roof inhibiting wind flow (>50% blockage).
- For values of θ other than those shown, linear interpolation is permitted.
- Plus and minus signs signify pressures acting towards and away from the top roof surface, respectively.
- Components and cladding elements shall be designed for positive and negative pressure coefficients shown.
- Notation:
 α : 10% of least horizontal dimension or 0.411, whichever is smaller but not less than 4% of least horizontal dimension or 0.9 m
 h : mean roof height, m
 L : horizontal dimension of building, measured in along wind direction, m
 θ : angle of plane of roof from horizontal, degrees

Figure 6.2.19(b) Net pressure coefficient, C_N for components and cladding ($0.25 \leq h/L \leq 1.0$)

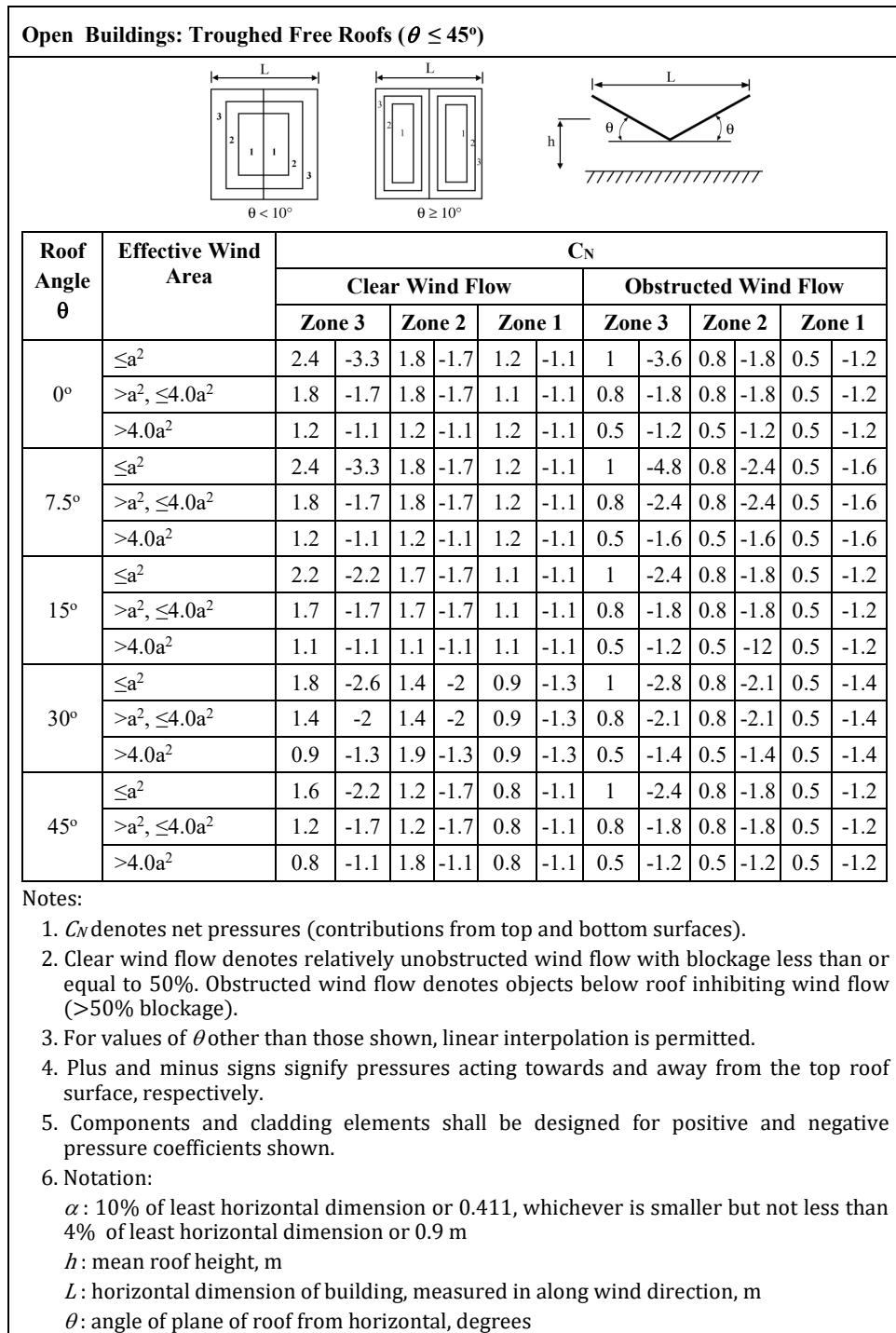
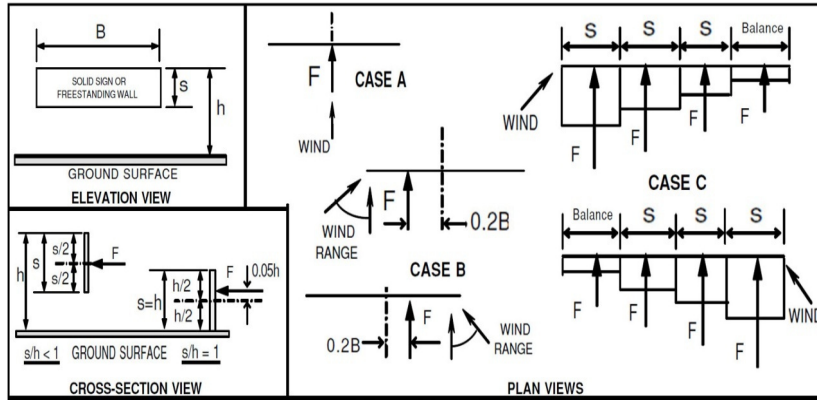


Figure 6.2.19(c) Net pressure coefficient, C_N for components and cladding ($0.25 \leq h/L \leq 1.0$)

Solid Freestanding Walls & Solid Signs



C_f , CASE A & CASE B

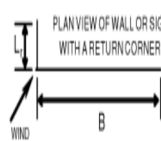
Clearance Ratio, s/h	Aspect Ratio, B/s											
	≤ 0.05	0.1	0.2	0.5	1	2	4	5	10	20	30	≥ 45
1	1.80	1.70	1.65	1.55	1.45	1.40	1.35	1.35	1.30	1.30	1.30	1.30
0.9	1.85	1.75	1.70	1.60	1.55	1.50	1.45	1.45	1.40	1.40	1.40	1.40
0.7	1.90	1.85	1.75	1.70	1.65	1.60	1.60	1.55	1.55	1.55	1.55	1.55
0.5	1.95	1.85	1.80	1.75	1.75	1.70	1.70	1.70	1.70	1.70	1.70	1.75
0.3	1.95	1.90	1.85	1.80	1.80	1.80	1.80	1.80	1.80	1.85	1.85	1.85
0.2	1.95	1.90	1.85	1.80	1.80	1.80	1.80	1.80	1.85	1.90	1.90	1.95
≤ 0.16	1.95	1.90	1.85	1.85	1.80	1.80	1.85	1.85	1.85	1.90	1.90	1.95

C_f , CASE C

Region (horizontal distance from windward edge)	Aspect Ratio, B/s									Region (horizontal distance from windward edge)	Aspect Ratio, B/s	
	2	3	4	5	6	7	8	9	10		13	≥ 45
0 to s	2.25	2.60	2.90	3.10*	3.30*	3.40*	3.55*	3.65*	3.75*	0 to s	4.00*	4.30*
s to $2s$	1.50	1.70	1.90	2.00	2.15	2.25	2.30	2.35	2.45	s to $2s$	2.60	2.55
$2s$ to $3s$		1.15	1.30	1.45	1.55	1.65	1.70	1.75	1.85	$2s$ to $3s$	2.00	1.95
$3s$ to $10s$			1.10	1.05	1.05	1.05	1.05	1.00	0.95	$3s$ to $4s$	1.50	1.85

*Values shall be multiplied by the following reduction factor when a return corner is present:

L_r/s	Reduction Factor
0.3	0.9
1.0	0.75
≥ 2	0.60



4s to 5s	1.35	1.85
5s to 10s	0.90	1.10
$> 10s$	0.55	0.55

Notes:

1. The term "signs" in notes below also applies to "freestanding walls".
2. Signs with openings comprising less than 30% of the gross area are classified as solid signs. Force coefficients for solid signs with openings shall be permitted to be multiplied by the reduction factor $(1 - (1 - \epsilon)^{1.5})$.
3. To allow for both normal and oblique wind directions, the following cases shall be considered:

For $s/h < 1$:

CASE A: resultant force acts normal to the face of the sign through the geometric center.

CASE B: resultant force acts normal to the face of the sign at a distance from the geometric center toward the windward edge equal to 0.2 times the average width of the sign.

For $B/s \geq 2$, CASE C must also be considered:

CASE C: resultant forces act normal to the face of the sign through the geometric centers of each region.

For $s/h = 1$:

The same cases as above except that the vertical locations of the resultant forces occur at a distance above the geometric center equal to 0.05 times the average height of the sign.
4. For CASE C where $s/h > 0.8$, force coefficients shall be multiplied by the reduction factor $(1.8 - s/h)$.
5. Linear interpolation is permitted for values of s/h , B/s and L_r/s other than shown.
6. Notation: B : horizontal dimension of sign, in meters;

h : height of the sign, in meters;

s : vertical dimension of the sign, in meters;

ϵ : ratio of solid area to gross area;

L_r : horizontal dimension of return corner, in meters

Figure 6.2.20 Force Coefficient, C_f for other structures - Method 2 (All heights)

Chimneys, Tanks, Rooftop Equipment, & Similar Structures				
Cross-Section	Type of Surface	h/D		
		1	7	25
Square (wind normal to face)	All	1.3	1.4	2.0
Square (wind along diagonal)	All	1.0	1.1	1.5
Hexagonal or octagonal	All	1.0	1.2	1.4
Round $D\sqrt{q_z} > 5.3, D$ in m, q_z in N/m^2	Moderately smooth	0.5	0.6	0.7
	Rough ($D'/D=0.02$)	0.7	0.8	0.9
	Very rough ($D'/D=0.08$)	0.8	1.0	0.2
Round $D\sqrt{q_z} \leq 5.3, D$ in m, q_z in N/m^2	All	0.7	0.8	1.2

Notes:

- The design wind force shall be calculated based on the area of the structure projected on a plane normal to the wind direction. The force shall be assumed to act parallel to the wind direction.
- Linear interpolation is permitted for h/D values other than shown.
- Notation:
 - D : diameter of circular cross-section and least horizontal dimension of square, hexagonal or octagonal cross-section at elevation under consideration, in meters;
 - D' : depth of protruding element such as ribs and spoilers, in meters;
 - H : height of structure, meters and
 - q_z : velocity pressure evaluated at height z above ground, in N/m^2

Figure 6.2.21 Force coefficient, C_f for other structures - Method 2 (All heights)

Open Signs & Lattice Frameworks			
ϵ	Flat-Sided Members	Rounded Members	
		$(D\sqrt{q_z} \leq 5.3,)$	$(D\sqrt{q_z} > 5.3,)$
<0.1	2.0	1.2	0.8
0.1 to 0.29	1.8	1.3	0.9
0.3 to 0.7	1.6	1.5	1.1

Notes:

1. Signs with openings comprising 30% or more of the gross area are classified as open signs.
2. The calculation of the design wind forces shall be based on the area of all exposed members and elements projected on a plane normal to the wind direction. Forces shall be assumed to act parallel to the wind.
3. The area A_f consistent with these force coefficients is the solid area projected normal the wind direction.
4. Notation:
 - ϵ : ratio of solid area to gross area;
 - D : diameter of a typical round member, in meters
 - q_z : velocity pressure evaluated at height z above ground in N/m^2 .

Figure 6.2.22 Force coefficient, C_f for other structures - Method 2 (All heights)

Table 6.2.8: Basic Wind Speeds, V , for Selected Locations in Bangladesh

Location	Basic Wind Speed (m/s)	Location	Basic Wind Speed (m/s)
Angarpota	47.8	Lalmonirhat	63.7
Bagerhat	77.5	Madaripur	68.1
Bandarban	62.5	Magura	65.0
Barguna	80.0	Manikganj	58.2
Barisal	78.7	Meherpur	58.2
Bhola	69.5	Maheshkhali	80.0
Bogra	61.9	Moulvibazar	53.0
Brahmanbaria	56.7	Munshiganj	57.1
Chandpur	50.6	Mymensingh	67.4
Chapai Nawabganj	41.4	Naogaon	55.2
Chittagong	80.0	Narail	68.6
Chuadanga	61.9	Narayanganj	61.1
Comilla	61.4	Narsinghdi	59.7
Cox's Bazar	80.0	Natore	61.9
Dahagram	47.8	Netrokona	65.6
Dhaka	65.7	Nilphamari	44.7
Dinajpur	41.4	Noakhali	57.1
Faridpur	63.1	Pabna	63.1
Feni	64.1	Panchagarh	41.4
Gaibandha	65.6	Patuakhali	80.0
Gazipur	66.5	Pirojpur	80.0
Gopalganj	74.5	Rajbari	59.1
Habiganj	54.2	Rajshahi	49.2
Hatiya	80.0	Rangamati	56.7
Ishurdi	69.5	Rangpur	65.3
Joypurhat	56.7	Satkhira	57.6
Jamalpur	56.7	Shariatpur	61.9
Jessore	64.1	Sherpur	62.5
Jhalakati	80.0	Sirajganj	50.6
Jhenaidah	65.0	Srimangal	50.6
Khagrachhari	56.7	St. Martin's Island	80.0
Khulna	73.3	Sunamganj	61.1
Kutubdia	80.0	Sylhet	61.1
Kishoreganj	64.7	Sandwip	80.0
Kurigram	65.6	Tangail	50.6
Kushtia	66.9	Teknaf	80.0
Lakshmipur	51.2	Thakurgaon	41.4

Open Structures: Trussed Tower	
Tower Cross Section	C_f
Square	$4.0 \epsilon^2 - 5.9 \epsilon + 4.0$
Triangle	$3.4 \epsilon^2 - 4.7 \epsilon + 3.4$

Notes:

1. For all wind directions considered, the area A_f consistent with the specified force coefficients shall be the solid area of a tower face projected on the plane of that face for the tower segment under consideration.
2. The specified force coefficients are for towers with structural angles or similar flat-sided members.
3. For towers containing rounded members, it is acceptable to multiply the specified force coefficients by the following factor when determining wind forces on such members: $0.51 \epsilon^2 + 0.57 \leq 1.0$
4. Wind forces shall be applied in the directions resulting in maximum member forces and reactions. For towers with square cross-sections, wind forces shall be multiplied by the following factor when the wind is directed along a tower diagonal:
 $1 + 0.75 \epsilon \leq 1.2$
5. Wind forces on tower appurtenances such as ladders, conduits, lights, elevators, etc., shall be calculated using appropriate force coefficients for these elements.
6. Notation:
 ϵ : ratio of solid area to gross area of one tower face for the segment under consideration.

Figure 6.2.23 Force coefficient, C_f for other structures - Method 2 (All heights)

Table 6.2.9: Importance Factor, I (Wind Loads)

Occupancy Category ¹ or Importance Class	Non-Cyclone Prone Regions and Cyclone Prone Regions with $V = 38-44$ m/s	Cyclone Prone Regions with $V > 44$ m/s
I	0.87	0.77
II	1.0	1.00
III	1.15	1.15
IV	1.15	1.15

¹ The building and structure classification categories are listed in Table 6.1.1

Table 6.2.10: Terrain Exposure Constants

Exposure	α	z_g (m)	\hat{a}	\hat{b}	$\bar{\alpha}$	\bar{b}	c	l (m)	\bar{e}	z_{min} (m)*
A	7.0	365.76	1/7	0.84	1/4.0	0.45	0.30	97.54	1/3.0	9.14
B	9.5	274.32	1/9.5	1.00	1/6.5	0.65	0.20	152.4	1/5.0	4.57
C	11.5	213.36	1/11.5	1.07	1/9.0	0.80	0.15	198.12	1/8.0	2.13

* z_{min} = Minimum height used to ensure that the equivalent height z is greater of $0.6h$ or z_{min} .

For buildings with $h \leq z_{min}$, \bar{z} shall be taken as z_{min} .

Table 6.2.11: Velocity Pressure Exposure Coefficients, K_h and K_z

Height above ground level, z (m)	Exposure (Note 1)			
	A		B	C
	Case 1	Case 2	Case 1 & 2	Case 1 & 2
0-4.6	0.70	0.57	0.85	1.03
6.1	0.70	0.62	0.90	1.08
7.6	0.70	0.66	0.94	1.12
9.1	0.70	0.70	0.98	1.16
12.2	0.76	0.76	1.04	1.22
15.2	0.81	0.81	1.09	1.27
18	0.85	0.85	1.13	1.31
21.3	0.89	0.89	1.17	1.34
24.4	0.93	0.93	1.21	1.38
27.41	0.96	0.96	1.24	1.40
30.5	0.99	0.99	1.26	1.43
36.6	1.04	1.04	1.31	1.48
42.7	1.09	1.09	1.36	1.52
48.8	1.13	1.13	1.39	1.55
54.9	1.17	1.17	1.43	1.58
61.0	1.20	1.20	1.46	1.61
76.2	1.28	1.28	1.53	1.68
91.4	1.35	1.35	1.59	1.73
106.7	1.41	1.41	1.64	1.78
121.9	1.47	1.47	1.69	1.82
137.2	1.52	1.52	1.73	1.86
152.4	1.56	1.56	1.77	1.89

Notes:

1. Case 1:

- (a) All components and cladding.
- (b) Main wind force resisting system in low-rise buildings designed using Figure 6.2.10.

Case 2:

- (a) All main wind force resisting systems in buildings except those in low-rise buildings designed using Figure 6.2.10.
- (b) All main wind force resisting systems in other structures.

2. The velocity pressure exposure coefficient K_z may be determined from the following formula:

$$\text{For } 4.57 \text{ m} \leq z \leq z_g: \quad K_z = 2.01 (z/z_g)^{2/\alpha}$$

$$\text{For } z < 4.57 \text{ m:} \quad K_z = 2.01 (4.57/z_g)^{2/\alpha}$$

Note: z shall not be taken less than 9.1 m for Case 1 in exposure A.

3. α and z_g are tabulated in Table 6.2.10.4. Linear interpolation for intermediate values of height z is acceptable.

5. Exposure categories are defined in Sec 2.4.6.3.

Table 6.2.12: Wind Directionality Factor, K_d

Structure Type	Directionality Factor K_d *	Structure Type	Directionality Factor K_d *
Buildings		Solid Signs	0.85
Main Wind Force Resisting System	0.85	Open Signs and Lattice Framework	0.85
Components and Cladding	0.85	Trussed Towers	
Arched Roofs	0.85	Triangular, square, rectangular	0.85
Chimneys, Tanks, and Similar Structures		All other cross section	0.95
Square	0.90		
Hexagonal	0.95		
Round	0.95		

* Directionality Factor K_d has been calibrated with combinations of loads specified in Sec 2.7. This factor shall only be applied when used in conjunction with load combinations specified in Sections 2.7.2 and 2.7.3.

2.5 Earthquake Loads

2.5.1 General

Minimum design earthquake forces for buildings, structures or components thereof shall be determined in accordance with the provisions of Sec 2.5. Some definitions and symbols relevant for earthquake resistant design for buildings are provided in Sections 2.1.3 and 2.1.4. Section 2.5.2 presents basic earthquake resistant design concepts. Section 2.5.3 describes procedures for soil investigations, while Sec 2.5.4 describes procedures for determining earthquake ground motion for design. Section 2.5.5 describes different types of buildings and structural systems which possess different earthquake resistant characteristics. Static analysis procedures for design are described in Sections 2.5.6, 2.5.7 and 2.5.12. Dynamic analysis procedures are dealt with in Sections 2.5.8 to 2.5.11. Section 2.5.13 presents how seismic effects are accounted in the design and combination of earthquake loading effects in different directions and with other loading effects. Section 2.5.14 deals with allowable drift and deformation limits. Section 2.5.15 addresses design of non-structural components in buildings. Section 2.5.16 presents design considerations for buildings with seismic isolation systems. Design for soft storey condition in buildings is addressed in Sec 2.5.17.

2.5.2 Earthquake Resistant Design – Basic Concepts

2.5.2.1 General principles

The purpose of earthquake resistant design provisions in this Code is to provide guidelines for the design and construction of new structures subject to earthquake ground motions in order to minimize the risk to life for all structures, to increase the expected performance of higher occupancy structures as compared to ordinary structures, and to improve the capability of essential structures to function after an earthquake. It is not economically feasible to design and construct buildings without any damage for a major earthquake event. The intent is therefore to allow inelastic deformation and structural damage at preferred locations in the structure without endangering structural integrity and to prevent structural collapse during a major earthquake.

The seismic zoning map (Fig. 6.2.24) divides the country into four seismic zones with different expected levels of intensity of ground motion. Each seismic zone has a zone coefficient which provides expected peak ground acceleration values on rock/firm soil corresponding to the maximum considered earthquake (MCE). The design basis earthquake is taken as 2/3 of the maximum considered earthquake.

The effects of the earthquake ground motion on the structure is expressed in terms of an idealized elastic design acceleration response spectrum, which depends on (a) seismic zone coefficient and local soil conditions defining ground motion and (b) importance factor and response reduction factor representing building considerations. The earthquake forces acting on the structure is reduced using the response modification/reduction factor R in order to take advantage of the inelastic energy dissipation due to inherent ductility and redundancy in the structure as well as material over-strength. The importance factor I increases design forces for important structures. The provisions of this Code for ductility and detailing need to be satisfied even for structures and members for which load combinations that do not contain the earthquake effect indicate larger demands than combinations including earthquake. The elastic deformations calculated under these reduced design forces are multiplied by the deflection amplification factor, C_d to estimate the deformations likely to result from the design earthquake.

The seismic design guidelines presented in this Section are based on the assumption that the soil supporting the structure will not liquefy, settle or slide due to loss of strength during the earthquake. Reinforced and prestressed concrete members shall be suitably designed to ensure that premature failure due to shear or bond does not occur. Ductile detailing of reinforced concrete members is of prime importance. In steel structures, members and their connections should be so proportioned that high ductility is obtained, avoiding premature failure due to elastic or inelastic buckling of any type.

The building structure shall include complete lateral and vertical force-resisting systems capable of providing adequate strength, stiffness, and energy dissipation capacity to withstand the design ground motions within the prescribed limits of deformation and strength demand. The design ground motions shall be assumed to occur along any horizontal direction of a building structure. The adequacy of the structural systems shall be demonstrated through the construction of a mathematical model and evaluation of this model for the effects of design ground motions.

2.5.2.2 Characteristics of Earthquake Resistant Buildings

The desirable characteristics of earthquake resistant buildings are described below:

Structural Simplicity, Uniformity and Symmetry:

Structural simplicity, uniformity and plan symmetry is characterized by an even distribution of mass and structural elements which allows short and direct transmission of the inertia forces created in the distributed masses of the building to its foundation. A building configuration with symmetrical layout of

structural elements of the lateral force resisting system, and well-distributed in-plan, is desirable. Uniformity along the height of the building is also important, since it tends to eliminate the occurrence of sensitive zones where concentrations of stress or large ductility demands might cause premature collapse.

Some basic guidelines are given below:

- (i) With respect to the lateral stiffness and mass distribution, the building structure shall be approximately symmetrical in plan with respect to two orthogonal axes.
- (ii) Both the lateral stiffness and the mass of the individual storeys shall remain constant or reduce gradually, without abrupt changes, from the base to the top of a particular building.
- (iii) All structural elements of the lateral load resisting systems, such as cores, structural walls, or frames shall run without interruption from the foundations to the top of the building.
- (iv) An irregular building may be subdivided into dynamically independent regular units well separated against pounding of the individual units to achieve uniformity.
- (v) The length to breadth ratio ($\lambda = L_{max}/L_{min}$) of the building in plan shall not be higher than 4, where L_{max} and L_{min} are respectively the larger and smaller in plan dimension of the building, measured in orthogonal directions.

Structural Redundancy:

A high degree of redundancy accompanied by redistribution capacity through ductility is desirable, enabling a more widely spread energy dissipation across the entire structure and an increased total dissipated energy. The use of evenly distributed structural elements increases redundancy. Structural systems of higher static indeterminacy may result in higher response reduction factor R .

Horizontal Bi-directional Resistance and Stiffness:

Horizontal earthquake motion is a bi-directional phenomenon and thus the building structure needs to resist horizontal action in any direction. The structural elements of lateral force resisting system should be arranged in an orthogonal (in plan) pattern, ensuring similar resistance and stiffness characteristics in both main directions. The stiffness characteristics of the structure should also limit the development of excessive displacements that might lead to either instabilities due to second order effects or excessive damages.

Torsional Resistance and Stiffness

Besides lateral resistance and stiffness, building structures should possess adequate torsional resistance and stiffness in order to limit the development of torsional motions which tend to stress the different structural elements in a non-uniform way. In this respect, arrangements in which the main elements resisting the seismic action are distributed close to the periphery of the building present clear advantages.

Diaphragm Behaviour

In buildings, floors (including the roof) act as horizontal diaphragms that collect and transmit the inertia forces to the vertical structural systems and ensure that those systems act together in resisting the horizontal seismic action. Floor systems and the roof should be provided with in-plane stiffness and resistance and with effective connection to the vertical structural systems. Particular care should be taken in cases of non-compact or very elongated in-plan shapes and in cases of large floor openings, especially if the latter are located in the vicinity of the main vertical structural elements, thus hindering such effective connection between the vertical and horizontal structure. The in-plane stiffness of the floors shall be sufficiently large in comparison with the lateral stiffness of the vertical structural elements, so that the deformation of the floor shall have a small effect on the distribution of the forces among the vertical structural elements.

Foundation

The design and construction of the foundation and of its connection to the superstructure shall ensure that the whole building is subjected to a uniform seismic excitation. For buildings with individual foundation elements (footings or piles), the use of a foundation slab or tie-beams between these elements in both main directions is recommended, as described in Chapter 3.

2.5.3 Investigation and Assessment of Site Conditions

2.5.3.1 Site investigation

Appropriate site investigations should be carried out to identify the ground conditions influencing the seismic action.

The ground conditions at the building site should normally be free from risks of ground rupture, slope instability and permanent settlements caused by liquefaction or densification during an earthquake. The possibility of such phenomena should be investigated in accordance with standard procedures described in Chapter 3 of this Part.

The intent of the site investigation is to classify the Site into one of types SA, SB, SC, SD, SE, S₁ and S₂ as defined in Sec 2.5.3.2. Such classification is based on site profile and evaluated soil properties (shear wave velocity, Standard Penetration Resistance, undrained shear strength, soil type). The site class is used to determine the effect of local soil conditions on the earthquake ground motion.

For sites representing special soil type S₁ or S₂, site specific special studies for the ground motion should be done. Soil type S₁, having very low shear wave velocity and low material damping, can produce anomalous seismic site amplification and soil-structure interaction effects. For S₂ soils, possibility of soil failure should be studied.

For a structure belonging to Seismic Design Category C or D (Sec 2.5.5.2), site investigation should also include determination of soil parameters for the assessment of the following:

- (a) Slope instability.
- (b) Potential for Liquefaction and loss of soil strength.
- (c) Differential settlement.
- (d) Surface displacement due to faulting or lateral spreading.
- (e) Lateral pressures on basement walls and retaining walls due to earthquake ground motion.

Liquefaction potential and possible consequences should be evaluated for design earthquake ground motions consistent with peak ground accelerations. Any Settlement due to densification of loose granular soils under design earthquake motion should be studied. The occurrence and consequences of geologic hazards such as slope instability or surface faulting should also be considered. The dynamic lateral earth pressure on basement walls and retaining walls during earthquake ground shaking is to be considered as an earthquake load for use in design load combinations

2.5.3.2 Site classification

Site will be classified as type SA, SB, SC, SD, SE, S₁ and S₂ based on the provisions of this Section. Classification will be done in accordance with Table 6.2.13 based on the soil properties of upper 30 meters of the site profile. Average soil properties will be determined as given in the following equations:

$$\bar{V}_s = \sum_{i=1}^n d_i / \sum_{i=1}^n \frac{d_i}{V_{si}} \quad (6.2.31)$$

$$\bar{N} = \sum_{i=1}^n d_i / \sum_{i=1}^n \frac{d_i}{N_i} \quad (6.2.32)$$

$$\bar{S}_u = \sum_{i=1}^k d_{ci} / \sum_{i=1}^k \frac{d_{ci}}{S_{ui}} \quad (6.2.33)$$

Where,

n = Number of soil layers in upper 30 m

d_i = Thickness of layer i

V_{si} = Shear wave velocity of layer i

N_i = Field (uncorrected) Standard Penetration Value for layer i

k = Number of cohesive soil layers in upper 30 m

d_{ci} = Thickness of cohesive layer i

s_{ui} = Undrained shear strength of cohesive layer i

The site profile up to a depth of 30 m is divided into n number of distinct soil or rock layers. Where some of the layers are cohesive, k is the number of cohesive layers. Hence $\sum_{i=1}^n d_i = 30$ m, while $\sum_{i=1}^k d_{ci} < 30$ m if $k < n$ in other words if there are both cohesionless and cohesive layers. The standard penetration value N as directly measured in the field without correction will be used.

The site classification should be done using average shear wave velocity \bar{V}_s if this can be estimated, otherwise the value of \bar{N} may be used.

Table 6.2.13: Site Classification Based on Soil Properties

Site Class	Description of soil profile up to 30 meters depth	Average Soil Properties in top 30 meters		
		Shear wave velocity, \bar{V}_s (m/s)	SPT Value, \bar{N} (blows/30cm)	Undrained shear strength, \bar{S}_u (kPa)
SA	Rock or other rock-like geological formation, including at most 5 m of weaker material at the surface.	> 800	--	--
SB	Deposits of very dense sand, gravel, or very stiff clay, at least several tens of metres in thickness, characterised by a gradual increase of mechanical properties with depth.	360 – 800	> 50	> 250

Site Class	Description of soil profile up to 30 meters depth	Average Soil Properties in top 30 meters		
		Shear wave velocity, \bar{V}_s (m/s)	SPT Value, \bar{N} (blows/30cm)	Undrained shear strength, \bar{S}_u (kPa)
SC	Deep deposits of dense or medium dense sand, gravel or stiff clay with thickness from several tens to many hundreds of metres.	180 – 360	15 - 50	70 - 250
SD	Deposits of loose-to-medium cohesionless soil (with or without some soft cohesive layers), or of predominantly soft-to-firm cohesive soil.	< 180	< 15	< 70
SE	A soil profile consisting of a surface alluvium layer with V_s values of type SC or SD and thickness varying between about 5 m and 20 m, underlain by stiffer material with $V_s > 800$ m/s.	--	--	--
S ₁	Deposits consisting, or containing a layer at least 10 m thick, of soft clays/silts with a high plasticity index (PI > 40) and high water content	< 100 (indicative)	--	10 - 20
S ₂	Deposits of liquefiable soils, of sensitive clays, or any other soil profile not included in types SA to SE or S ₁	--	--	--

2.5.4 Earthquake Ground Motion

2.5.4.1 Regional seismicity

Bangladesh can be affected by moderate to strong earthquake events due to its proximity to the collision boundary of the Northeast moving Indian plate and Eurasian Plate. Strong historical earthquakes with magnitude greater than 7.0 have affected parts of Bangladesh in the last 150 years, some of them had their epicenters within the country. A brief description of the local geology, tectonic features and earthquake occurrence in the region is given in Appendix B.

2.5.4.2 Seismic zoning

The intent of the seismic zoning map is to give an indication of the Maximum Considered Earthquake (MCE) motion at different parts of the country. In probabilistic terms, the MCE motion may be considered to correspond to having a 2% probability of exceedance within a period of 50 years. The country has been divided into four seismic zones with different levels of ground motion. Table 6.2.14 includes a description of the four seismic zones. Figure 6.2.24 presents a map of Bangladesh showing the boundaries of the four zones. Each zone has a seismic zone coefficient (Z) which represents the maximum considered peak ground acceleration (PGA) on very stiff soil/rock (site class SA) in units of g (acceleration due to gravity). The zone coefficients (Z) of the four zones are: $Z=0.12$ (Zone 1), $Z=0.20$ (Zone 2), $Z=0.28$ (Zone 3) and $Z=0.36$ (Zone 4). Table 6.2.15 lists zone coefficients for some important towns of Bangladesh. The most severe earthquake prone zone, Zone 4 is in the northeast which includes Sylhet and has a maximum PGA value of $0.36g$. Dhaka city falls in the moderate seismic intensity zone with $Z=0.2$, while Chittagong city falls in a severe intensity zone with $Z=0.28$.

2.5.4.3 Design response spectrum

The earthquake ground motion for which the building has to be designed is represented by the design response spectrum. Both static and dynamic analysis methods are based on this response spectrum. This spectrum represents the spectral acceleration for which the building has to be designed as a function of the building period, taking into account the ground motion intensity. The spectrum is based on elastic analysis but in order to account for energy dissipation due to inelastic deformation and benefits of structural redundancy, the spectral accelerations are reduced by the response modification factor R . For important structures, the spectral accelerations are increased by the importance factor I . The design basis earthquake (DBE) ground motion is

selected at a ground shaking level that is 2/3 of the maximum considered earthquake (MCE) ground motion. The effect of local soil conditions on the response spectrum is incorporated in the normalized acceleration response spectrum C_s . The spectral acceleration for the design earthquake is given by the following equation:

$$S_a = \frac{2}{3} \frac{ZI}{R} C_s \quad (6.2.34)$$

Where,

S_a = Design spectral acceleration (in units of g) which shall not be less than $0.67\beta ZI S$

β = Coefficient used to calculate lower bound for S_a . Recommended value for β is 0.11

Z = Seismic zone coefficient, as defined in Sec 2.5.4.2

I = Structure importance factor, as defined in Sec 2.5.5.1

R = Response reduction factor which depends on the type of structural system given in Table 6.2.19. The ratio $\frac{I}{R}$ cannot be greater than one.

C_s = Normalized acceleration response spectrum, which is a function of structure (building) period and soil type (site class) as defined by Equations 6.2.35a to 6.2.35d.

$$C_s = S \left(1 + \frac{T}{T_B} (2.5\eta - 1) \right) \quad \text{for } 0 \leq T \leq T_B \quad (6.2.35a)$$

$$C_s = 2.5 S \eta \quad \text{for } T_B \leq T \leq T_C \quad (6.2.35b)$$

$$C_s = 2.5 S \eta \left(\frac{T_C}{T} \right) \quad \text{for } T_C \leq T \leq T_D \quad (6.2.35c)$$

$$C_s = 2.5 S \eta \left(\frac{T_C T_D}{T^2} \right) \quad \text{for } T_D \leq T \leq 4 \text{ sec} \quad (6.2.35d)$$

C_s depends on S and values of T_B , T_C and T_D , (Figure 6.2.25) which are all functions of the site class. Constant C_s value between periods T_B and T_C represents constant spectral acceleration.

S = Soil factor which depends on site class and is given in Table 6.2.16

T = Structure (building) period as defined in Sec 2.5.7.2

T_B = Lower limit of the period of the constant spectral acceleration branch given in Table 6.2.16 as a function of site class.

T_C = Upper limit of the period of the constant spectral acceleration branch given in Table 6.2.16 as a function of site class

T_D = Lower limit of the period of the constant spectral displacement branch given in Table 6.2.16 as a function of site class

η = Damping correction factor as a function of damping with a reference value of $\eta=1$ for 5% viscous damping. It is given by the following expression:

$$\eta = \sqrt{10/(5 + \xi)} \geq 0.55 \quad (6.2.36)$$

Where, ξ is the viscous damping ratio of the structure, expressed as a percentage of critical damping. The value of η cannot be smaller than 0.55.

The anticipated (design basis earthquake) peak ground acceleration (PGA) for rock or very stiff soil (site class SA) is $\frac{2}{3}Z$. However, for design, the ground motion is modified through the use of response reduction factor R and importance factor I , resulting in $PGA_{rock} = \frac{2}{3} \left(\frac{ZI}{R} \right)$. Figure 6.2.26 shows the normalized acceleration response spectrum C_s for 5% damping, which may be defined as the 5% damped spectral acceleration (obtained by Eq. 6.2.34) normalized with respect to PGA_{rock} . This Figure demonstrates the significant influence of site class on the response spectrum.

Design Spectrum for Elastic Analysis

For site classes SA to SE, the design acceleration response spectrum for elastic analysis methods is obtained using Eq. 6.2.34 to compute S_a (in units of g) as a function of period T . The design acceleration response spectrum represents the expected ground motion (Design Basis Earthquake) divided by the factor R/I .

Design Spectrum for Inelastic Analysis

For inelastic analysis methods, the anticipated ground motion (Design Basis Earthquake) is directly used. Corresponding real design acceleration response spectrum is used, which is obtained by using $R=1$ and $I=1$ in Eq. 6.2.34. The 'real design acceleration response spectrum' is equal to 'design acceleration response spectrum' multiplied by R/I .

Site-Specific Design Spectrum

For site class S_1 and S_2 , site-specific studies are needed to obtain design response spectrum. For important projects, site-specific studies may also be carried out to determine spectrum instead of using Eq. 6.2.34. The objective of such site-specific ground-motion analysis is to determine ground motions for local seismic and site conditions with higher confidence than is possible using simplified equations.

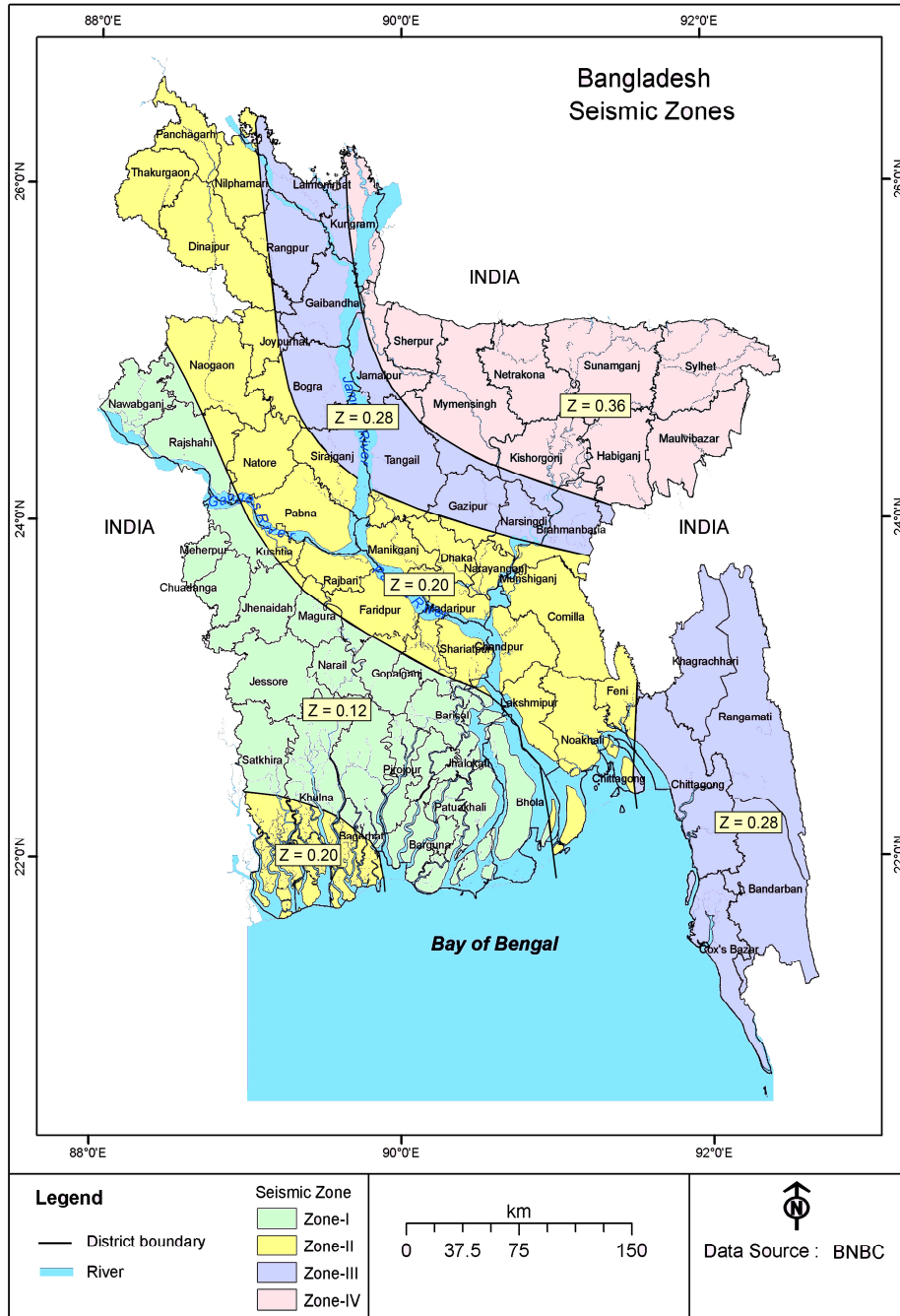


Figure 6.2.24 Seismic zoning map of Bangladesh

Table 6.2.14: Description of Seismic Zones

Seismic Zone	Location	Seismic Intensity	Seismic Zone Coefficient, Z
1	Southwestern part including Barisal, Khulna, Jessore, Rajshahi	Low	0.12
2	Lower Central and Northwestern part including Noakhali, Dhaka, Pabna, Dinajpur, as well as Southwestern corner including Sundarbans	Moderate	0.20
3	Upper Central and Northwestern part including Brahmanbaria, Sirajganj, Rangpur	Severe	0.28
4	Northeastern part including Sylhet, Mymensingh, Kurigram	Very Severe	0.36

Table 6.2.15: Seismic Zone Coefficient Z for Some Important Towns of Bangladesh

Town	Z	Town	Z	Town	Z	Town	Z
Bagerhat	0.12	Gaibandha	0.28	Magura	0.12	Patuakhali	0.12
Bandarban	0.28	Gazipur	0.20	Manikganj	0.20	Pirojpur	0.12
Barguna	0.12	Gopalganj	0.12	Maulvibazar	0.36	Rajbari	0.20
Barisal	0.12	Habiganj	0.36	Meherpur	0.12	Rajshahi	0.12
Bhola	0.12	Jaipurhat	0.20	Mongla	0.12	Rangamati	0.28
Bogra	0.28	Jalpur	0.36	Munshiganj	0.20	Rangpur	0.28
Brahmanbaria	0.28	Jessore	0.12	Mymensingh	0.36	Satkhira	0.12
Chandpur	0.20	Jhalokati	0.12	Narail	0.12	Shariatpur	0.20
Chapainabaganj	0.12	Jhenaidah	0.12	Narayanganj	0.20	Sherpur	0.36
Chittagong	0.28	Khagrachari	0.28	Narsingdi	0.28	Sirajganj	0.28
Chuadanga	0.12	Khulna	0.12	Natore	0.20	Srimangal	0.36
Comilla	0.20	Kishoreganj	0.36	Naogaon	0.20	Sunamganj	0.36
Cox's Bazar	0.28	Kurigram	0.36	Netrakona	0.36	Sylhet	0.36
Dhaka	0.20	Kushtia	0.20	Nilphamari	0.12	Tangail	0.28
Dinajpur	0.20	Lakshmipur	0.20	Noakhali	0.20	Thakurgaon	0.20
Faridpur	0.20	Lalmanirhat	0.28	Pabna	0.20		
Feni	0.20	Madaripur	0.20	Panchagarh	0.20		

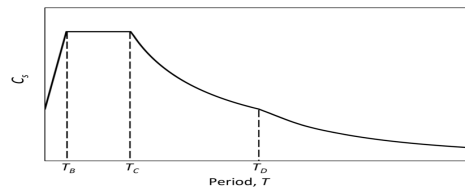
Figure 6.2.25 Typical shape of the elastic response spectrum coefficient C_s

Table 6.2.16: Site Dependent Soil Factor and Other Parameters Defining Elastic Response Spectrum

Soil type	S	T_b (s)	T_c (s)	T_d (s)
SA	1.0	0.15	0.40	2.0
SB	1.2	0.15	0.50	2.0
SC	1.15	0.20	0.60	2.0
SD	1.35	0.20	0.80	2.0
SE	1.4	0.15	0.50	2.0

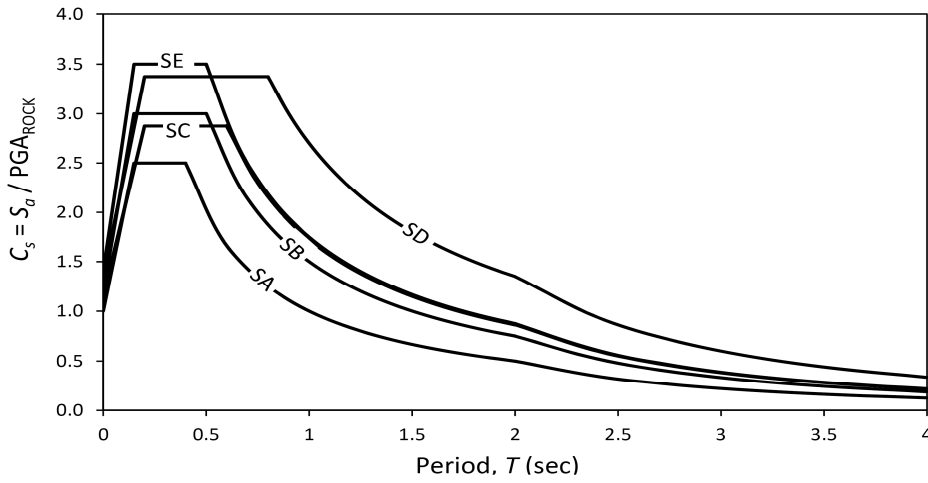


Figure 6.2.26 Normalized design acceleration response spectrum for different site classes.

2.5.5 Building Categories

2.5.5.1 Importance factor

Buildings are classified in four occupancy categories in Chapter 1 (Table 6.1.1), depending on the consequences of collapse for human life, on their importance for public safety and civil protection in the immediate post-earthquake period, and on the social and economic consequences of collapse. Depending on occupancy category, buildings may be designed for higher seismic forces using importance factor greater than one. Table 6.2.17 defines different occupancy categories and corresponding importance factor.

Table 6.2.17: Importance Factors for Buildings and Structures for Earthquake design

Occupancy Category	Importance factor I
I, II	1.00
III	1.25
IV	1.50

2.5.5.2 Seismic design category

Buildings shall be assigned a seismic design category among B, C or D based on seismic zone, local site conditions and importance class of building, as given in Table 6.2.18. Seismic design category D has the most stringent seismic design detailing, while seismic design category B has the least seismic design detailing requirements.

Table 6.2.18: Seismic Design Category of Buildings

Site Class	Occupancy Category I, II and III				Occupancy Category IV			
	Zone 1	Zone 2	Zone 3	Zone 4	Zone 1	Zone 2	Zone 3	Zone 4
SA	B	C	C	D	C	D	D	D
SB	B	C	D	D	C	D	D	D
SC	B	C	D	D	C	D	D	D
SD	C	D	D	D	D	D	D	D
SE, S ₁ , S ₂	D	D	D	D	D	D	D	D

2.5.5.3 Building irregularity

Buildings with irregularity in plan or elevation suffer much more damage in earthquakes than buildings with regular configuration. A building may be considered as irregular, if at least one of the conditions given below are applicable:

2.5.5.3.1 Plan irregularity: Following are the different types of irregularities that may exist in the plan of a building.

(i) Torsion irregularity

To be considered for rigid floor diaphragms, when the maximum storey drift (Δ_{max}) as shown in Figure 6.2.27(a), computed including accidental torsion, at one end of the structure is more than 1.2 times the average ($\Delta_{avg} = \frac{\Delta_{max} + \Delta_{min}}{2}$) of the storey drifts at the two ends of the structure. If $\Delta_{max} > 1.4\Delta_{avg}$ then the irregularity is termed as extreme torsional irregularity.

(ii) Re-entrant corners

Both projections of the structure beyond a re-entrant corner [Figure 6.2.27(b)] are greater than 15 percent of its plan dimension in the given direction.

(iii) Diaphragm Discontinuity

Diaphragms with abrupt discontinuities or variations in stiffness, including those having cut-out [Figure 6.2.27(c)] or open areas greater than 50 percent of the gross enclosed diaphragm area, or changes in effective diaphragm stiffness of more than 50 percent from one storey to the next.

(iv) Out- of-Plane Offsets

Discontinuities in a lateral force resistance path, such as out-of-plane offsets of vertical elements, as shown in Figure 6.2.27(d).

(v) Non-parallel Systems

The vertical elements resisting the lateral force are not parallel to or symmetric [Figure 6.2.27(e)] about the major orthogonal axes of the lateral force resisting elements.

2.5.5.3.2 Vertical Irregularity: Following are different types of irregularities that may exist along vertical elevations of a building.

(i) Stiffness Irregularity - Soft Storey

A soft storey is one in which the lateral stiffness is less than 70% of that in the storey above or less than 80% of the average lateral stiffness of the three storeys above irregularity [Figure 6.2.28(a)]. An extreme soft storey is defined where its lateral stiffness is less than 60% of that in the storey above or less than 70% of the average lateral stiffness of the three storeys above.

(ii) Mass Irregularity

The seismic weight of any storey is more than twice of that of its adjacent storeys [Figure 6.2.28(b)]. This irregularity need not be considered in case of roofs.

(iii) Vertical Geometric Irregularity

This irregularity exists for buildings with setbacks with dimensions given in Figure [6.2.28(c)].

(iv) Vertical In-Plane Discontinuity in Vertical Elements Resisting Lateral Force

An in-plane offset of the lateral force resisting elements greater than the length of those elements [Figure 6.2.28(d)].

(v) Discontinuity in Capacity - Weak Storey

A weak storey is one in which the storey lateral strength is less than 80% of that in the storey above. The storey lateral strength is the total strength of all seismic force resisting elements sharing the storey shear in the considered direction [Figure 6.2.28(e)]. An extreme weak storey is one where the storey lateral strength is less than 65% of that in the storey above.

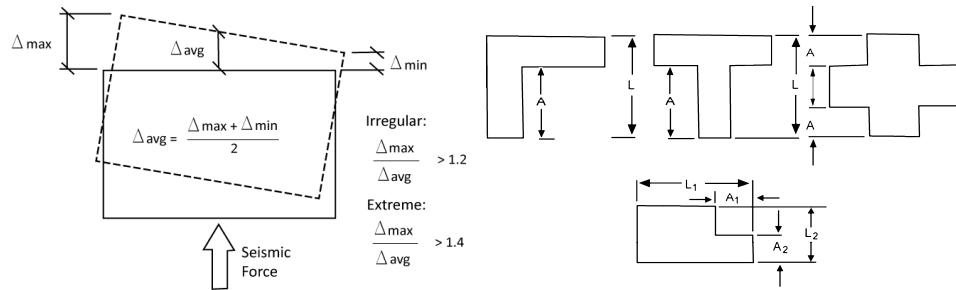
2.5.5.4 Type of structural systems

The basic lateral and vertical seismic force-resisting system shall conform to one of the types A to G indicated in Table 6.2.19. Each type is again subdivided by the types of vertical elements used to resist lateral seismic forces. A combination of systems may also be permitted as stated in Sec 2.5.5.5.

The structural system to be used shall be in accordance with the seismic design category indicated in Table 6.2.18. Structural systems that are not permitted for a certain seismic design category are indicated by “NP”. Structural systems that do not have any height restriction are indicated by “NL”. Where there is height limit, the maximum height in meters is given.

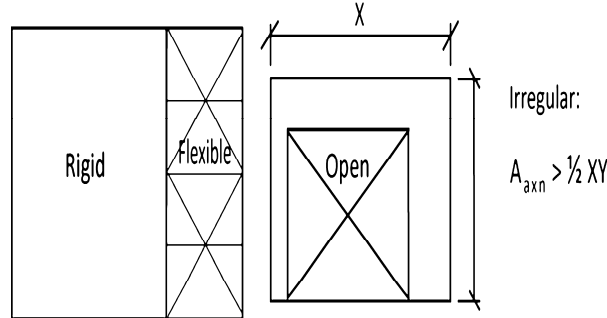
The response reduction factor, R , and the deflection amplification factor, C_d indicated in Table 6.2.19 shall be used in determining the design base shear and design story drift. The selected seismic force-resisting system shall be designed and detailed in accordance with the specific requirements for the system.

Seismic force resisting systems that are not given in Table 6.2.19 may be permitted if substantial analytical and test data are submitted that establish the dynamic characteristics and demonstrate the lateral force resistance and energy dissipation capacity to be equivalent to the structural systems listed in Table 6.2.19 for equivalent response modification coefficient, R , and deflection amplification factor, C_d values.

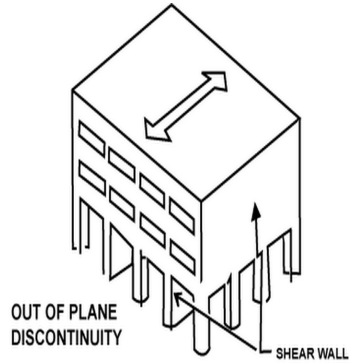


(a) Torsional Irregularity

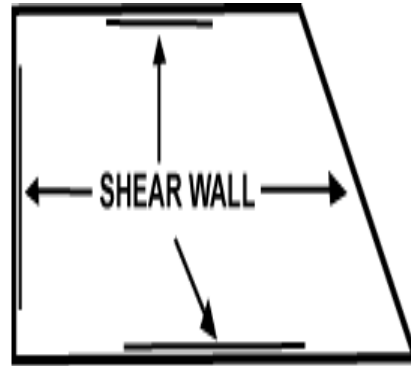
(b) Re-entrant corners ($A/L > 0.15$)



(c) Diaphragm discontinuity

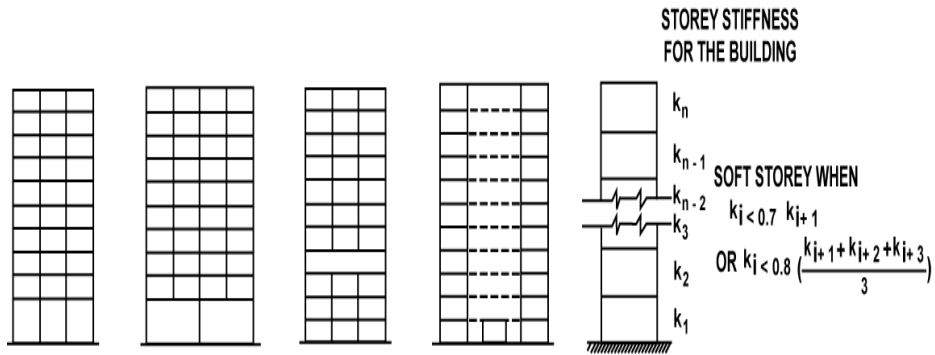


(d) Out- of-plane offsets of shear wall

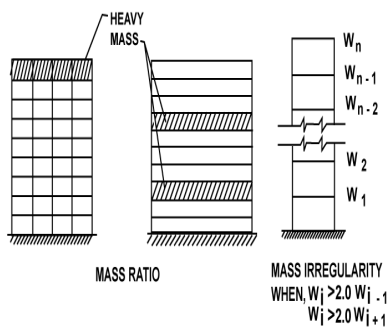


(e) Non-parallel systems of shear wall

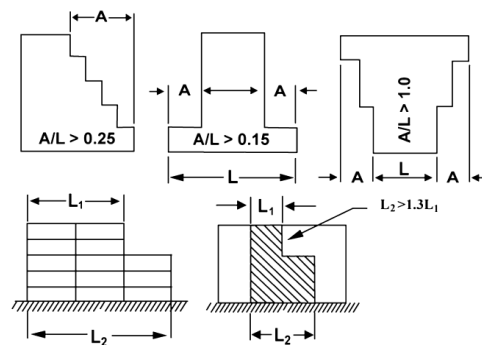
Figure 6.2.27 Different types of plan irregularities of buildings



(a) Soft storey



(b) Mass irregularity



(c) Vertical geometric irregularity (setback structures)

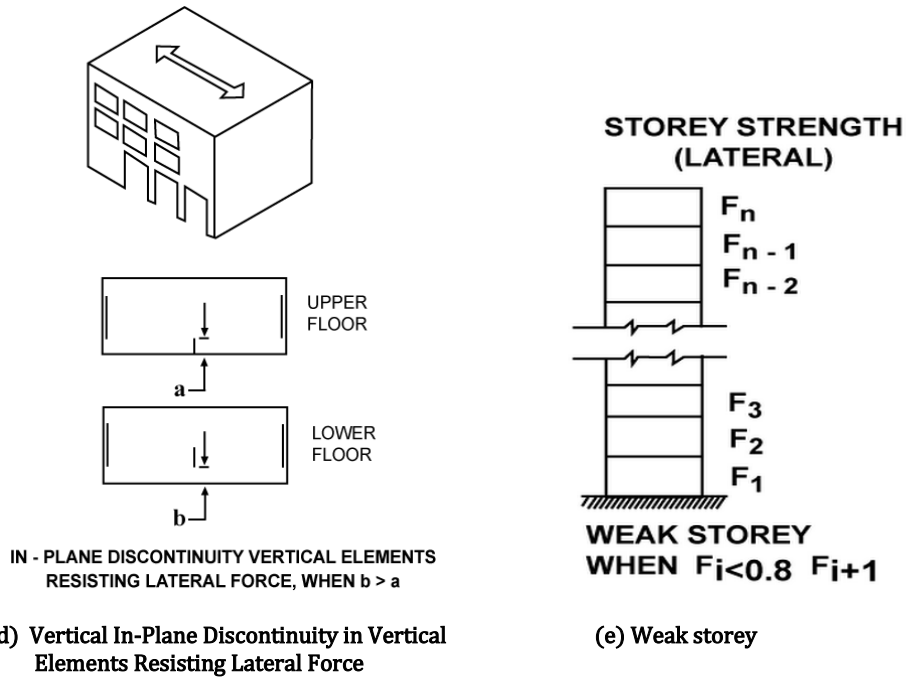


Figure 6.2.28 Different types of vertical irregularities of buildings

Table 6.2.19: Response Reduction Factor, Deflection Amplification Factor and Height Limitations for Different Structural Systems

Seismic Force-Resisting System	Response Reduction Factor, R	System Overstrength Factor, Ω_o	Deflection Amplification Factor, C_d	Seismic Design Category B	Seismic Design Category C	Seismic Design Category D
				Height limit (m)		
A. BEARING WALL SYSTEMS (no frame)						
1. Special reinforced concrete shear walls	5	2.5	5	NL	NL	50
2. Ordinary reinforced concrete shear walls	4	2.5	4	NL	NL	NP
3. Ordinary reinforced masonry shear walls	2	2.5	1.75	NL	50	NP
4. Ordinary plain masonry shear walls	1.5	2.5	1.25	18	NP	NP

Seismic Force-Resisting System	Response Reduction Factor, R	System Overstrength Factor, Ω_o	Deflection Amplification Factor, C_d	Seismic Design Category B	Seismic Design Category C	Seismic Design Category D
				Height limit (m)		
B. BUILDING FRAME SYSTEMS (with bracing or shear wall)						
1. Steel eccentrically braced frames, moment resisting connections at columns away from links	8	2	4	NL	NL	50
2. Steel eccentrically braced frames, non-moment-resisting, connections at columns away from links	7	2	4	NL	NL	50
3. Special steel concentrically braced frames	6	2	5	NL	NL	50
4. Ordinary steel concentrically braced frames	3.25	2	3.25	NL	NL	11
5. Special reinforced concrete shear walls	6	2.5	5	NL	NL	50
6. Ordinary reinforced concrete shear walls	5	2.5	4.25	NL	NL	NP
7. Ordinary reinforced masonry shear walls	2	2.5	2	NL	50	NP
8. Ordinary plain masonry shear walls	1.5	2.5	1.25	18	NP	NP
C. MOMENT RESISTING FRAME SYSTEMS (no shear wall)						
1. Special steel moment frames	8	3	5.5	NL	NL	NL
2. Intermediate steel moment frames	4.5	3	4	NL	NL	35
3. Ordinary steel moment frames	3.5	3	3	NL	NL	NP

Seismic Force-Resisting System	Response Reduction Factor, R	System Overstrength Factor, Ω_o	Deflection Amplification Factor, C_d	Seismic Design Category B	Seismic Design Category C	Seismic Design Category D
				Height limit (m)		
4. Special reinforced concrete moment frames	8	3	5.5	NL	NL	NL
5. Intermediate reinforced concrete moment frames	5	3	4.5	NL	NL	NP
5. Ordinary reinforced concrete moment frames	3	3	2.5	NL	NP	NP
D. DUAL SYSTEMS: SPECIAL MOMENT FRAMES CAPABLE OF RESISTING AT LEAST 25% OF PRESCRIBED SEISMIC FORCES (with bracing or shear wall)						
1. Steel eccentrically braced frames	8	2.5	4	NL	NL	NL
2. Special steel concentrically braced frames	7	2.5	5.5	NL	NL	NL
3. Special reinforced concrete shear walls	7	2.5	5.5	NL	NL	NL
4. Ordinary reinforced concrete shear walls	6	2.5	5	NL	NL	NP
E. DUAL SYSTEMS: INTERMEDIATE MOMENT FRAMES CAPABLE OF RESISTING AT LEAST 25% OF PRESCRIBED SEISMIC FORCES (with bracing or shear wall)						
1. Special steel concentrically braced frames	6	2.5	5	NL	NL	11
2. Special reinforced concrete shear walls	6.5	2.5	5	NL	NL	50
3. Ordinary reinforced masonry shear walls	3	3	3	NL	50	NP

Seismic Force-Resisting System	Response Reduction Factor, R	System Overstrength Factor, Ω_o	Deflection Amplification Factor, C_d	Seismic Design Category B	Seismic Design Category C	Seismic Design Category D
				Height limit (m)		
4. Ordinary reinforced concrete shear walls	5.5	2.5	4.5	NL	NL	NP
F. DUAL SHEAR WALL-FRAME SYSTEM: ORDINARY REINFORCED CONCRETE MOMENT FRAMES AND ORDINARY REINFORCED CONCRETE SHEAR WALLS	4.5	2.5	4	NL	NP	NP
G. STEEL SYSTEMS NOT SPECIFICALLY DETAILED FOR SEISMIC RESISTANCE	3	3	3	NL	NL	NP

Notes:

1. Seismic design category, NL = No height restriction, NP = Not permitted. Number represents maximum allowable height (m).
2. Dual Systems include buildings which consist of both moment resisting frame and shear walls (or braced frame) where both systems resist the total design forces in proportion to their lateral stiffness.
3. See Sec. 10.20 of Chapter 10 of this Part for additional values of R and C_d and height limits for some other types of steel structures not covered in this Table.
4. Where data specific to a structure type is not available in this Table, reference may be made to Table 12.2-1 of ASCE 7-05.

2.5.5.5 Combination of structural systems

2.5.5.5.1 Combinations of Structural Systems in Different Directions: Different seismic force-resisting systems are permitted to be used to resist seismic forces along each of the two orthogonal axes of the structure. Where different systems are used, the respective R and C_d coefficients shall apply to each system, including the limitations on system use contained in Table 6.2.19.

2.5.5.5.2 Combinations of Structural Systems in the Same Direction: Where different seismic force-resisting systems are used in combination to resist seismic forces in the same direction of structural response, other than those combinations considered as dual systems, the more stringent system limitation contained in Table 6.2.19 shall apply. The value of R used for design in that direction shall not be greater than the least value of R for any of the systems utilized in that direction. The deflection amplification factor, C_d in the direction under consideration at any story shall not be less than the largest value of this factor for the R factor used in the same direction being considered.

2.5.5.6 Provisions for Using System Overstrength Factor, Ω_o

2.5.5.6.1 Combinations of Elements Supporting Discontinuous Walls or Frames.

Columns, beams, trusses, or slabs supporting discontinuous walls or frames of structures having horizontal irregularity Type IV of Table 6.1.5 or vertical irregularity Type IV of Table 6.1.4 shall have the design strength to resist the maximum axial force that can develop in accordance with the load combinations with overstrength factor of Section 2.5.13.4. The connections of such discontinuous elements to the supporting members shall be adequate to transmit the forces for which the discontinuous elements were required to be designed.

2.5.5.6.2 Increase in Forces Due to Irregularities for Seismic Design Category D.

For structures assigned to Seismic Design Category D and having a horizontal structural irregularity of Type I.a, I.b, II, III, or IV in Table 6.1.5 or a vertical structural irregularity of Type IV in Table 6.1.4, the design forces determined from Section 2.5.7 shall be increased 25 percent for connections of diaphragms to vertical elements and to collectors and for connections of collectors to the vertical elements. Collectors and their connections also shall be designed for these increased forces unless they are designed for the load combinations with overstrength factor of Section 2.5.5.4, in accordance with Section 2.5.13.4.

2.5.5.6.3 Collector Elements Requiring Load Combinations with Overstrength Factor for Seismic Design Categories C through D.

In structures assigned to Seismic Design Category C or D, collector elements, splices, and their connections to resisting elements shall resist the load combinations with overstrength of Section 2.5.13.4.

2.5.5.6.4 Batter Piles.

Batter piles and their connections shall be capable of resisting forces and moments from the load combinations with overstrength factor of Section 2.5.13.4. Where vertical and batter piles act jointly to resist foundation forces as a group, these forces shall be distributed to the individual piles in accordance with their relative horizontal and vertical rigidities and the geometric distribution of the piles within the group.

2.5.6 Static Analysis Procedure

Although analysis of buildings subjected to dynamic earthquake loads should theoretically require dynamic analysis procedures, for certain type of building structures subjected to earthquake shaking, simplified static analysis procedures may also provide reasonably good results. The equivalent static force method is such a procedure for determining the seismic lateral forces acting on the structure. This type of analysis may be applied to buildings whose seismic response is not significantly affected by contributions from modes higher than the fundamental mode in each direction. This requirement is deemed to be satisfied in buildings which fulfill the following two conditions:

- (a) The building period in the two main horizontal directions is smaller than both $4 T_c$ (T_c is defined in Sec 2.5.4.3) and 2 seconds.
- (b) The building does not possess irregularity in elevation as defined in Sec 2.5.5.3.

2.5.7 Equivalent Static Analysis

The evaluation of the seismic loads starts with the calculation of the design base shear which is derived from the design response spectrum presented in Sec 2.5.4.3. This Section presents different computations relevant to the equivalent static analysis procedure.

2.5.7.1 Design base shear

The seismic design base shear force in a given direction shall be determined from the following relation:

$$V = S_a W \quad (6.2.37)$$

Where,

S_a = Lateral seismic force coefficient calculated using Eq. 6.2.34 (Sec 2.5.4.3). It is the design spectral acceleration (in units of g) corresponding to the building period T (computed as per Sec 2.5.7.2).

W = Total seismic weight of the building defined in Sec 2.5.7.3

Alternatively, for buildings with natural period less than or equal to 2.0 sec., the seismic design base shear can be calculated using ASCE 7-02 with seismic design parameters as given in Appendix C. However, the minimum value of S_a should not be less than $0.044 S_{DS}$. The values of S_{DS} are provided in Table 6.C.4 of Appendix C.

2.5.7.2 Building period

The fundamental period T of the building in the horizontal direction under consideration shall be determined using the following guidelines:

- Structural dynamics procedures (such as Rayleigh method or modal eigenvalue analysis), using structural properties and deformation characteristics of resisting elements, may be used to determine the fundamental period T of the building in the direction under consideration. This period shall not exceed the approximate fundamental period determined by Eq. 6.2.38 by more than 40 percent.
- The building period T (in sec) may be approximated by the following formula:

$$T = C_t(h_n)^m \quad (6.2.38)$$

Where,

h_n = Height of building in metres from foundation or from top of rigid basement. This excludes the basement storeys, where basement walls are connected with the ground floor deck or fitted between the building columns. But it includes the basement storeys, when they are not so connected. C_t and m are obtained from Table 6.2.20

- For masonry or concrete shear wall structures, the approximate fundamental period, T (in sec) may be determined as follows:

$$T = \frac{0.0062}{\sqrt{C_w}} h_n \quad (6.2.39)$$

$$C_w = \frac{100}{A_B} \sum_{i=1}^x \left(\frac{h_n}{h_i} \right)^2 \left[\frac{A_i}{1 + 0.83 \left(\frac{h_i}{D_i} \right)^2} \right] \quad (6.2.40)$$

Where,

A_B = area of base of structure h_i = height of shear wall “i”
 A_i = web area of shear wall “i” x = number of shear walls in the building
 D_i = length of shear wall “i” effective in resisting lateral forces in the
direction under consideration.

Table 6.2.20: Values for Coefficients to Estimate Approximate Period

Structure type	C_t	m	
Concrete moment-resisting frames	0.0466	0.9	Note: Consider moment resisting frames as frames which resist 100% of seismic force and are not enclosed or adjoined by components that are more rigid and will prevent the frames from deflecting under seismic forces.
Steel moment-resisting frames	0.0724	0.8	
Eccentrically braced steel frame	0.0731	0.75	
All other structural systems	0.0488	0.75	

2.5.7.3 Seismic weight

Seismic weight, W , is the total dead load of a building or a structure, including partition walls, and applicable portions of other imposed loads listed below:

- (a) For live load up to and including 3 kN/m², a minimum of 25 percent of the live load shall be applicable.
- (b) For live load above 3 kN/m², a minimum of 50 percent of the live load shall be applicable.
- (c) Total weight (100 percent) of permanent heavy equipment or retained liquid or any imposed load sustained in nature shall be included.

Where the probable imposed loads (mass) at the time of earthquake are more correctly assessed, the designer may go for higher percentage of live load.

2.5.7.4 Vertical distribution of lateral forces

In the absence of a more rigorous procedure, the total seismic lateral force at the base level, in other words the base shear V , shall be considered as the sum of lateral forces F_x induced at different floor levels, these forces may be calculated as:

$$F_x = V \frac{w_x h_x^k}{\sum_{i=1}^n w_i h_i^k} \quad (6.2.41)$$

Where,

F_x = Part of base shear force induced at level x

w_i and w_x = Part of the total effective seismic weight of the structure (W) assigned to level i or x

h_i and h_x = the height from the base to level i or x

$k = 1$ For structure period ≤ 0.5 s

= 2 for structure period ≥ 2.5 s

= linear interpolation between 1 and 2 for other periods.

n = number of stories

2.5.7.5 Storey shear and its horizontal distribution

The design storey shear V_x , at any storey x is the sum of the forces F_x in that storey and all other stories above it, given by Eq. 6.2.42:

$$V_x = \sum_{i=x}^n F_i \quad (6.2.42)$$

Where, F_i = Portion of base shear induced at level i , as determined by Eq. 6.2.41.

If the floor diaphragms can be considered to be infinitely rigid in the horizontal plane, the shear V_x shall be distributed to the various elements of the lateral force resisting system in proportion to their relative lateral stiffness. For flexible diaphragms, the distribution of forces to the vertical elements shall account for the position and distribution of the masses supported.

Allowance shall also be made for the increased shear arising due to horizontal torsional moment as specified in Sec 2.5.7.6

2.5.7.6 Horizontal torsional moments

Design shall accommodate increase in storey shear forces resulting from probable horizontal torsional moments on rigid floor diaphragms. Computation of such moments shall be as follows:

2.5.7.6.1 In-built torsional effects: When there is in-built eccentricity between centre of mass and centre of rigidity (lateral resistance) at floor levels, rigid diaphragms at each level will be subject to torsional moment M_t .

2.5.7.6.2 Accidental torsional effects: In order to account for uncertainties in the location of masses and in the spatial variation of the seismic motion, accidental torsional effects need to be always considered. The accidental moment M_{ta} is determined assuming the storey mass to be displaced from the calculated centre of mass a distance equal to 5 percent of the building dimension at that level perpendicular to the direction of the force under consideration. The accidental torsional moment M_{tai} at level i is given as:

$$M_{tai} = e_{ai}F_i \quad (6.2.43)$$

Where,

e_{ai} = accidental eccentricity of floor mass at level i applied in the same direction at all floors = $\pm 0.05L_i$

L_i = floor dimension perpendicular to the direction of seismic force considered.

Where torsional irregularity exists (Sec 2.5.5.3.1) for Seismic Design Category C or D, the irregularity effects shall be accounted for by increasing the accidental torsion M_{ta} at each level by a torsional amplification factor, A_x as illustrated in Figure 6.2.29 determined from the following equation:

$$A_x = \left[\frac{\delta_{max}}{1.2\delta_{avg}} \right]^2 \leq 3.0 \quad (6.2.44)$$

Where,

δ_{max} = Maximum displacement at level- x computed assuming $A_x = 1$.

δ_{avg} = Average displacements at extreme points of the building at level- x computed assuming $A_x = 1$.

The accidental torsional moment need not be amplified for structures of light-frame construction. Also the torsional amplification factor (A_x) should not exceed 3.0.

2.5.7.6.3 Design for torsional effects: The torsional design moment at a given storey shall be equal to the accidental torsional moment M_{ta} plus the inbuilt torsional moment M_t (if any). Where earthquake forces are applied concurrently in two orthogonal directions, the required 5 percent displacement of the center of mass (for accidental torsion) need not be applied in both of the orthogonal directions at the same time, but shall be applied in only one direction that produces the greater effect.

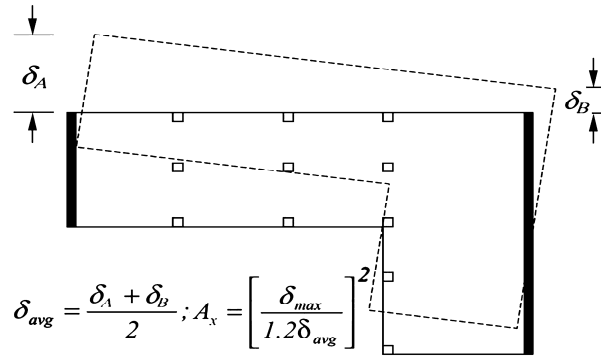


Figure 6.2.29 Torsional amplification factor A_x for plan irregularity.

2.5.7.7 Deflection and storey drift

The deflections (δ_x) of level x at the center of the mass shall be determined in accordance with the following equation:

$$\delta_x = \frac{C_d \delta_{xe}}{I} \quad (6.2.45)$$

Where,

C_d = Deflection amplification factor given in Table 6.2.19

δ_{xe} = Deflection determined by an elastic analysis

I = Importance factor defined in Table 6.2.17

The design storey drift at storey x shall be computed as the difference of the deflections at the centers of mass at the top and bottom of the story under consideration:

$$\Delta_x = \delta_x - \delta_{x-1} \quad (6.2.46)$$

2.5.7.8 Overturning effects

The structure shall be designed to resist overturning effects caused by the seismic forces determined in Sec 2.5.7.4. At any story, the increment of overturning moment in the story under consideration shall be distributed to the various vertical force resisting elements in the same proportion as the distribution of the horizontal shears to those elements. The overturning moments at level x , M_x shall be determined as follows:

$$M_x = \sum_{i=x}^n F_i (h_i - h_x) \quad (6.2.47)$$

Where,

F_i = Portion of the seismic base shear, V induced at level i

h_i, h_x = Height from the base to level i or x .

The foundations of structures, except inverted pendulum-type structures, shall be permitted to be designed for three-fourths of the foundation overturning design moment, M_o determined using above equation.

2.5.7.9 P-delta effects

The P-delta effects on story shears and moments, the resulting member forces and moments, and the story drifts induced by these effects are not required to be considered if the stability coefficient (θ) determined by the following equation is not more than 0.10:

$$\theta = \frac{P_x \Delta}{V_x h_{sx} C_d} \quad (6.2.48)$$

Where,

P_x = Total vertical design load at and above level x ; where computing P_x , no individual load factor need exceed 1.0

Δ = Design story drift occurring simultaneously with V_x

V_x = Storey shear force acting between levels x and $x - 1$

h_{sx} = Storey height below level x

C_d = Deflection amplification factor given in Table 6.2.19

The stability coefficient θ shall not exceed θ_{max} determined as follows:

$$\theta_{max} = \frac{0.5}{\beta C_d} \leq 0.25 \quad (6.2.49)$$

Where, β is the ratio of shear demand to shear capacity for the story between levels x and $x - 1$. This ratio is permitted to be conservatively taken as 1.0.

Where, the stability coefficient θ is greater than 0.10 but less than or equal to θ_{max} , the incremental factor related to P-delta effects on displacements and member forces shall be determined by rational analysis. Alternatively, it is permitted to multiply displacements and member forces by $\frac{1}{(1-\theta)}$.

Where, θ is greater than θ_{max} , the structure is potentially unstable and shall be redesigned.

Where, the P-delta effect is included in an automated analysis, Eq. 6.2.49 shall still be satisfied, however, the value of θ computed from Eq. 6.2.48 using the results of the P-delta analysis is permitted to be divided by $(1 + \theta)$ before checking Eq. 6.2.49.

2.5.8 Dynamic Analysis Methods

Dynamic analysis method involves applying principles of structural dynamics to compute the response of the structure to applied dynamic (earthquake) loads.

2.5.8.1 Requirement for dynamic analysis

Dynamic analysis should be performed to obtain the design seismic force, and its distribution to different levels along the height of the building and to the various lateral load resisting elements, for the following buildings:

- (a) Regular buildings with height greater than 40 m in Zones 2, 3, 4 and greater than 90 m in Zone 1.
- (b) Irregular buildings (as defined in Sec 2.5.5.3) with height greater than 12 m in Zones 2, 3, 4 and greater than 40 m in Zone 1.

For irregular buildings, smaller than 40 m in height in Zone 1, dynamic analysis, even though not mandatory, is recommended.

2.5.8.2 Methods of analysis

Dynamic analysis may be carried out through the following two methods:

- (i) Response Spectrum Analysis method is a linear elastic analysis method using modal analysis procedures, where the structure is subjected to spectral accelerations corresponding to a design acceleration response spectrum. The design earthquake ground motion in this case is represented by its response spectrum.
- (ii) Time History Analysis method is a numerical integration procedure where design ground motion time histories (acceleration record) are applied at the base of the structure. Time history analysis procedures can be two types: linear and non-linear.

2.5.9 Response Spectrum Analysis (RSA)

A response spectrum analysis shall consist of the analysis of a linear mathematical model of the structure to determine the maximum accelerations, forces, and displacements resulting from the dynamic response to ground shaking represented by the design acceleration response spectrum (presented in Sec 2.5.4.3). Response spectrum analysis is also called a modal analysis procedure because it considers different modes of vibration of the structure and combines effects of different modes.

2.5.9.1 Modeling (RSA)

A mathematical model of the structure shall be constructed that represents the spatial distribution of mass and stiffness throughout the structure. For regular structures with independent orthogonal seismic-force-resisting systems, independent two-dimensional models are permitted to be constructed to represent each system. For irregular structures or structures without independent orthogonal systems, a three-dimensional model incorporating a minimum of three dynamic degrees of freedom consisting of translation in two orthogonal plan directions and torsional rotation about the vertical axis shall be included at each level of the structure. Where the diaphragms are not rigid compared to the vertical elements of the lateral-force-resisting system, the model should include representation of the diaphragm's flexibility and such additional dynamic degrees of freedom as are required to account for the participation of the diaphragm in the structure's dynamic response. The structure shall be considered to be fixed at the base or, alternatively, it shall be permitted to use realistic assumptions with regard to the stiffness of foundations. In addition, the model shall comply with the following:

- (a) Stiffness properties of concrete and masonry elements shall consider the effects of cracked sections
- (b) The contribution of panel zone deformations to overall story drift shall be included for steel moment frame resisting systems.

2.5.9.2 Number of modes (RSA)

An analysis shall be conducted using the masses and elastic stiffnesses of the seismic-force-resisting system to determine the natural modes of vibration for the structure including the period of each mode, the modal shape vector ϕ , the modal participation factor P and modal mass M . The analysis shall include a sufficient number of modes to obtain a combined modal mass participation of at least 90 percent of the actual mass in each of two orthogonal directions.

2.5.9.3 Modal story shears and moments (RSA)

For each mode, the story shears, story overturning moments, and the shear forces and overturning moments in vertical elements of the structural system at each level due to the seismic forces shall be computed. The peak lateral force F_{ik} induced at level i in mode k is given by:

$$F_{ik} = A_k \phi_{ik} P_k W_i \quad (6.2.50)$$

Where,

A_k = Design horizontal spectral acceleration corresponding to period of vibration T_k of mode k obtained from design response spectrum (Sec 2.5.4.3)

ϕ_{ik} = Modal shape coefficient at level i in mode k

P_k = Modal participation factor of mode k

W_i = Weight of floor i .

2.5.9.4 Structure response (RSA)

In the response spectrum analysis method, the base shear V_{rs} ; each of the story shear, moment, and drift quantities; and the deflection at each level shall be determined by combining their modal values. The combination shall be carried out by taking the square root of the sum of the squares (SRSS) of each of the modal values or by the complete quadratic combination (CQC) technique. The complete quadratic combination shall be used where closely spaced periods in the translational and torsional modes result in cross-correlation of the modes.

The distribution of horizontal shear shall be in accordance with the requirements of Sec 2.5.7.5. It should be noted that amplification of accidental torsion as per Sec 2.5.7.6 is not required where accidental torsional effects are included in the dynamic analysis model by offsetting the centre of mass in each story by the required amount.

A base shear, V shall also be calculated using the equivalent static force procedure in Sec 2.5.7. Where the base shear, V_{rs} is less than 85 percent of V , all the forces but not the drifts obtained by response spectrum analysis shall be multiplied by the ratio $\frac{0.85V}{V_{rs}}$.

The displacements and drifts obtained by response spectrum analysis shall be multiplied by C_d/I to obtain design displacements and drifts, as done in equivalent static analysis procedure (Sec 2.5.7.7). The P-delta effects shall be determined in accordance with Sec 2.5.7.9.

2.5.10 Linear Time History Analysis (LTHA)

A linear time history analysis (LTHA) shall consist of an analysis of a linear mathematical model of the structure to determine its response, through direct numerical integration of the differential equations of motion, to a number of ground motion acceleration time histories compatible with the design response spectrum for the site. The analysis shall be performed in accordance with the provisions of this Section. For the purposes of analysis, the structure shall be permitted to be considered to be fixed at the base or, alternatively, it shall be permitted to use realistic assumptions with regard to the stiffness of foundations. The acceleration time history (ground motion) is applied at the base of the structure. The advantage of this procedure is that the time dependent behavior of the structural response is obtained.

2.5.10.1 Modeling (LTHA)

Mathematical models shall conform to the requirements of modeling described in Sec 2.5.9.1.

2.5.10.2 Ground motion (LTHA)

At least three appropriate ground motions (acceleration time history) shall be used in the analysis. Ground motion shall conform to the requirements of this Section.

Two-dimensional analysis: Where two-dimensional analyses are performed, each ground motion shall consist of a horizontal acceleration time history selected from an actual recorded event. Appropriate acceleration histories shall be obtained from records of events having magnitudes, fault distance, and source mechanisms that are consistent with those that control the maximum considered earthquake. Where the required number of appropriate ground motion records are not available, appropriate simulated ground motion time histories shall be used to make up the total number required. The ground motions shall be scaled such that for each period between $0.2T$ and $1.5T$ (where T is the natural period of the structure in the fundamental mode for the direction considered) the average of the five-percent-damped response spectra for the each acceleration time history is not less than the corresponding ordinate of the design acceleration response spectrum, determined in accordance with Sec 2.5.4.3.

Three-dimensional analysis: Where three-dimensional analysis is performed, ground motions shall consist of pairs of appropriate horizontal ground motion acceleration time histories (in two orthogonal horizontal directions) that shall be selected and scaled from individual recorded events. Appropriate ground motions shall be selected from events having magnitudes, fault distance, and source mechanisms that are consistent with those that control the maximum considered earthquake. Where the required number of recorded ground motion pairs are not available, appropriate simulated ground motion pairs shall be used to make up the total number required. For each pair of horizontal ground motion components, an SRSS spectrum shall be constructed by taking the square root of the sum of the squares of the five-percent-damped response spectra for the components (where an identical scale factor is applied to both components of a pair). Each pair of motions shall be scaled such that for each period between $0.2T$ and $1.5T$ (where T is the natural period of the fundamental mode of the structure) the average of the SRSS spectra from all horizontal component pairs is not less than 1.3 times the corresponding ordinate of the design response spectrum, determined in accordance with Sec 2.5.4.3.

2.5.10.3 Structure response (LTHA)

For each scaled acceleration time history, the maximum values of base shear and other structure response quantities shall be obtained from the time history analysis. For three dimensional analysis, orthogonal pair of scaled motions are applied simultaneously. A base shear, V , shall also be calculated using the equivalent static force procedure described in Sec 2.5.7.1. Where the maximum base shear, V_{th} computed by linear time history analysis, is less than V , all response quantities (storey shear, moments, drifts, floor deflections, member forces etc) obtained by time history analysis shall be increased by multiplying with the ratio, $\frac{V}{V_{th}}$. If number of earthquake records (or pairs) used in the analysis is less than seven, the maximum structural response obtained corresponding to different earthquake records shall be considered as the design value. If the number is at least seven, then the average of maximum structural responses for different earthquake records shall be considered as the design value.

The displacements and drifts obtained as mentioned above shall be multiplied by $\frac{C_d}{I}$ to obtain design displacements and drifts, as done in equivalent static analysis procedure (Sec 2.5.7.7).

2.5.11 Non-Linear Time History Analysis (NTHA)

Nonlinear time history analysis (NTHA) shall consist of analysis of a mathematical model of the structure which incorporates the nonlinear hysteretic behavior of the structure's components to determine its response, through methods of numerical integration, to ground acceleration time histories compatible with the design response spectrum for the site. The analysis shall be performed in accordance with the requirements of this Section. For the purposes of analysis, the structure shall be permitted to be considered to be fixed at the base or, alternatively, it shall be permitted to use realistic assumptions with regard to the stiffness of foundations. The acceleration time history (ground motion) is applied at the base of the structure. The advantage of this procedure is that actual time dependent behavior of the structural response considering inelastic deformations in the structure can be obtained.

2.5.11.1 Modeling (NTHA)

A mathematical model of the structure shall be constructed that represents the spatial distribution of mass throughout the structure. The hysteretic behavior of elements shall be modeled consistent with suitable laboratory test data and shall account for all significant yielding, strength degradation, stiffness degradation, and hysteretic pinching indicated by such test data. Strength of elements shall be based on expected values considering material over-strength, strain hardening, and hysteretic strength degradation. As a minimum, a bilinear force deformation relationship should be used at the element level. In reinforced concrete and masonry buildings, the elastic stiffness should correspond to that of cracked sections. Linear properties, consistent with the provisions of Chapter 5 shall be permitted to be used for those elements demonstrated by the analysis to remain within their linear range of response. The structure shall be assumed to have a fixed base or, alternatively, it shall be permitted to use realistic assumptions with regard to the stiffness and load carrying characteristics of the foundations consistent with site-specific soils data and rational principles of engineering mechanics.

For regular structures with independent orthogonal seismic-force-resisting systems, independent two dimensional models shall be permitted to be constructed to represent each system. For structures having plan irregularity or structures without independent orthogonal systems, a three-dimensional model incorporating a minimum of three dynamic degrees of freedom consisting of

translation in two orthogonal plan directions and torsional rotation about the vertical axis at each level of the structure shall be used. Where the diaphragms are not rigid compared to the vertical elements of the lateral-force-resisting system, the model shall include representation of the diaphragm's flexibility and such additional dynamic degrees of freedom as are required to account for the participation of the diaphragm in the structure's dynamic response.

2.5.11.2 Ground motion (NTHA)

The actual time-dependent inelastic deformation of the structure is modeled. For inelastic analysis method, the real design acceleration response spectrum (Sec 2.5.4.3) is obtained using Eq. 6.2.34 with $R=1$ and $I=1$. The real design acceleration response spectrum is the true representation of the expected ground motion (design basis earthquake) including local soil effects and corresponds to a peak ground acceleration (PGA) value of $\frac{2}{3}ZS$.

At least three appropriate acceleration time histories shall be used in the analysis. Ground motion shall conform to the requirements of this Section.

Two-dimensional analysis

Where two-dimensional analyses are performed, each ground motion shall consist of a horizontal acceleration time history selected from an actual recorded event. Appropriate acceleration histories shall be obtained from records of events having magnitudes, fault distance, and source mechanisms that are consistent with those that control the maximum considered earthquake. Where the required number of appropriate ground motion records are not available, appropriate simulated ground motion time histories shall be used to make up the total number required. The ground motions shall be scaled such that for each period between $0.2T$ and $1.5T$ (where T is the natural period of the structure in the fundamental mode for the direction considered) the average of the five-percent-damped response spectra for each acceleration time history is not less than the corresponding ordinate of the real design acceleration response spectrum, as defined here.

Three-dimensional analysis

Where three-dimensional analysis is performed, ground motions shall consist of pairs of appropriate horizontal ground motion acceleration time histories (in two orthogonal horizontal directions) that shall be selected and scaled from individual recorded events. Appropriate ground motions shall be selected from

events having magnitudes, fault distance, and source mechanisms that are consistent with those that control the maximum considered earthquake. Where the required number of recorded ground motion pairs are not available, appropriate simulated ground motion pairs shall be used to make up the total number required. For each pair of horizontal ground motion components, an SRSS spectrum shall be constructed by taking the square root of the sum of the squares of the five-percent-damped response spectra for the components (where an identical scale factor is applied to both components of a pair). Each pair of motions shall be scaled such that for each period between $0.2T$ and $1.5T$ (where T is the natural period of the fundamental mode of the structure) the average of the SRSS spectra from all horizontal component pairs is not less than 1.3 times the corresponding ordinate of the real design acceleration response spectrum.

2.5.11.3 Structure response (NTHA)

For each scaled acceleration time history, the maximum values of base shear and other structure response quantities shall be obtained from the nonlinear time history analysis. For three dimensional analysis, orthogonal pair of scaled motions are applied simultaneously. If number of earthquake records (or pairs) used in the analysis is less than seven, the maximum structural response obtained corresponding to different earthquake records shall be considered as the design value. If the number is at least seven, then the average of maximum structural responses for different earthquake records shall be considered as the design value. Since real expected earthquake motion input and model incorporating real nonlinear behavior of the structure is used, the results as obtained are directly used (no scaling as in LTHA or RSA is required) for interpretation and design.

2.5.11.4 Structure member design (NTHA)

The adequacy of individual members and their connections to withstand the design deformations predicted by the analyses shall be evaluated based on laboratory test data for similar components. The effects of gravity and other loads on member deformation capacity shall be considered in these evaluations. Member deformation shall not exceed two thirds of the smaller of: the value that results in loss of ability to carry gravity loads or the value at which member strength has deteriorated to less than 67 percent of peak strength.

2.5.11.5 Design review (NTHA)

Special care and expertise is needed in the use of nonlinear dynamic analysis based design. Checking of the design by competent third party is recommended. A review of the design of the seismic-force-resisting system and the supporting structural analyses shall be performed by an independent team consisting of design professionals with experience in seismic analysis methods and the theory and application of nonlinear seismic analysis and structural behavior under extreme cyclic loads. The design review shall include the following: (i) Review of development of ground motion time histories (ii) Review of acceptance criteria (including laboratory test data) used to demonstrate the adequacy of structural elements and systems to withstand the calculated force and deformation demands (iii) Review of structural design.

2.5.12 Non-Linear Static Analysis (NSA)

Nonlinear static analysis (NSA), also popularly known as pushover analysis, is a simplified method of directly evaluating nonlinear response of structures to strong earthquake ground shaking. It is an alternative to the more complex nonlinear time history analysis (NTHA). The building is subjected to monotonically increasing static horizontal loads under constant gravity load.

2.5.12.1 Modeling (NSA)

A mathematical model of the structure shall be constructed to represent the spatial distribution of mass and stiffness of the structural system considering the effects of element nonlinearity for deformation levels that exceed the proportional limit. P-Delta effects shall also be included in the analysis.

For regular structures with independent orthogonal seismic-force-resisting systems, independent two-dimensional models may be used to represent each system. For structures having plan irregularities or structures without independent orthogonal systems, a three-dimensional model incorporating a minimum of three degrees of freedom for each level of the structure, consisting of translation in two orthogonal plan directions and torsional rotation about the vertical axis, shall be used. Where the diaphragms are not rigid compared to the vertical elements of the seismic-force-resisting system, the model should include representation of the diaphragm flexibility.

Unless analysis indicates that an element remains elastic, a nonlinear force deformation model shall be used to represent the stiffness of the element before onset of yield, the yield strength, and the stiffness properties of the element after yield at various levels of deformation. Strengths of elements shall not

exceed expected values considering material over-strength and strain hardening. The properties of elements and components after yielding shall account for strength and stiffness degradation due to softening, buckling, or fracture as indicated by principles of mechanics or test data.

A control point shall be selected for the model. For normal buildings, the control point shall be at the center of mass of the highest level (roof) of the structure.

2.5.12.2 Analysis procedure (NSA)

The lateral forces shall be applied at the center of mass of each level and shall be proportional to the distribution obtained from a modal analysis for the fundamental mode of response in the direction under consideration. The lateral loads shall be increased incrementally in a monotonic manner.

At the j^{th} increment of lateral loading, the total lateral force applied to the model shall be characterized by the term V_j . The incremental increases in applied lateral force should be in steps that are sufficiently small to permit significant changes in individual element behavior (such as yielding, buckling or failure) to be detected. The first increment in lateral loading shall result in linear elastic behavior. At each loading step, the total applied lateral force, V_j the lateral displacement of the control point, δ_j and the forces and deformations in each element shall be recorded. The analysis shall be continued until the displacement of the control point is at least 150 percent of the target displacement determined in accordance with Sec.2.5.12.3. The structure shall be designed so that the total applied lateral force does not decrease in any load increment for control point displacements less than or equal to 125 percent of the target displacement.

2.5.12.3 Effective period and target displacement (NSA)

A bilinear curve shall be fitted to the capacity curve, such that the first segment of the bilinear curve coincides with the capacity curve at 60 percent of the effective yield strength, the second segment coincides with the capacity curve at the target displacement, and the area under the bilinear curve equals the area under the capacity curve, between the origin and the target displacement. The effective yield strength, V_y corresponds to the total applied lateral force at the intersection of the two line segments. The effective yield displacement, δ_y corresponds to the control point displacement at the intersection of the two line segments. The effective fundamental period, T_e of the structure in the direction under consideration shall be determined using Eq. 6.2.51 as follows:

$$T_e = T_1 \sqrt{\frac{V_1/\delta_1}{V_y/\delta_y}} \quad (6.2.51)$$

Where, V_1 , δ_1 , and T_1 are determined for the first increment of lateral load. The target displacement of the control point, δ_T shall be determined as follows:

$$\delta_T = C_0 C_1 S_a \left(\frac{T_e}{2\pi} \right)^2 g \quad (6.2.52)$$

Where, the spectral acceleration, S_a , is determined at the effective fundamental period, T_e , using Eq. 6.2.34, g is the acceleration due to gravity. The coefficient C_0 shall be calculated as :

$$C_0 = \frac{\sum_{i=1}^n w_i \phi_i}{\sum_{i=1}^n w_i \phi_i^2} \quad (6.2.53)$$

Where,

w_i = the portion of the seismic weight, W , at level i , and

ϕ_i = the amplitude of the shape vector at level i .

Where the effective fundamental period, T_e , is greater than T_C (defined in Sec. 2.5.4.3), the coefficient C_1 shall be taken as 1.0. Otherwise, the value of the coefficient C_1 shall be calculated as follows:

$$C_1 = \frac{1}{R_d} \left(1 + \frac{(R_d - 1) T_s}{T_e} \right) \quad (6.2.54)$$

Where, R_d is given as follows:

$$R_d = \frac{S_a}{V_y / W} \quad (6.2.55)$$

2.5.12.4 Structure member design (NSA)

For each nonlinear static analysis the design response parameters, including the individual member forces and member deformations shall be taken as the values obtained from the analysis at the step at which the target displacement is reached.

The adequacy of individual members and their connections to withstand the member forces and member deformations shall be evaluated based on laboratory test data for similar components. The effects of gravity and other loads on member deformation capacity shall be considered in these evaluations. The deformation of a member supporting gravity loads shall not exceed (i) two-thirds of the deformation that results in loss of ability to support gravity loads, and (ii) two-thirds of the deformation at which the member strength has deteriorated to less than 70 percent of the peak strength of the component model. The deformation of a member not required for gravity load support shall not exceed two-thirds of the value at which member strength has deteriorated to less than 70 percent of the peak strength of the component model.

2.5.12.5 Design review (NSA)

Checking of the design by competent third party is recommended. An independent team composed of at least two members with experience in seismic analysis methods and the theory and application of nonlinear seismic analysis and structural behavior under earthquake loading, shall perform a review of the design of the seismic force resisting system and the supporting structural analyses. The design review shall include (i) review of any site-specific seismic criteria (if developed) employed in the analysis (ii) review of the determination of the target displacement and effective yield strength of the structure (iii) review of adequacy of structural elements and systems to withstand the calculated force and deformation demands, together with laboratory and other data (iv) review of structural design.

2.5.13 Earthquake Load Effects and Load Combinations

The seismic load effect, E , shall be determined in accordance with the following:

1. For use in load combination 5 in Section 2.7.3 or load combination 5 and 6 in Section 2.7.2, E shall be determined in accordance with the following equation,

$$E = E_h + E_v$$

2. For use in load combination 7 in Section 2.7.3 or load combination 8 in Section 2.7.2, E shall be determined in accordance with following equation,

$$E = E_h - E_v$$

Where,

E = total seismic load effect

E_h = effect of horizontal seismic forces as defined in Sections 2.5.7 or 2.5.9

E_v = effect of vertical seismic forces as defined in Section 2.5.13.2

2.5.13.1 Horizontal earthquake loading, E_h

The horizontal seismic load effect, E_h , shall be taken as the horizontal load effects of seismic base shear V (Sec 2.5.7 or 2.5.9) or component forces F_c (Sec 2.5.15).

The directions of application of horizontal seismic forces for design shall be those which will produce the most critical load effects. Earthquake forces act in both principal directions of the building simultaneously. In order to account for that,

- (a) For structures of Seismic Design Category B, the design horizontal seismic forces are permitted to be applied independently in each of two orthogonal directions and orthogonal interaction effects are permitted to be neglected
- (b) Structures of Seismic Design Category C and D shall, as a minimum, conform to the requirements of (a) for Seismic Design Category B and in addition the requirements of this Section. The structure of Seismic Design Category C with plan irregularity type V and Seismic Design Category D shall be designed for 100% of the horizontal seismic forces in one principal direction combined with 30% of the horizontal seismic forces in the orthogonal direction. Possible combinations are:

“ $\pm 100\%$ in x-direction $\pm 30\%$ in y-direction” or

“ $\pm 30\%$ in x-direction $\pm 100\%$ in y-direction”

The combination which produces most unfavourable effect for the particular action effect shall be considered. This approach may be applied to equivalent static analysis, response spectrum analysis and linear time history analysis procedure.

- (c) Where three-dimensional analysis of a spatial structure model is performed as in 3D time history analysis, simultaneous application of accelerations in two directions shall be considered where the ground motions shall satisfy the conditions stated in Sections 2.5.10.2 or 2.5.11.2.

2.5.13.2 Vertical earthquake loading, E_v

The maximum vertical ground acceleration shall be taken as 50 percent of the expected horizontal peak ground acceleration (PGA). The vertical seismic load effect E_v may be determined as:

$$E_v = 0.50(a_h)D \quad (6.2.56)$$

Where,

$$a_h = \text{expected horizontal peak ground acceleration (in } g) \text{ for design} = (2/3)ZS$$

D = effect of dead load, S = site dependent soil factor (see Table 6.2.16).

2.5.13.3 Combination of earthquake loading with other loadings

When earthquake effect is included in the analysis and design of a building or structure, the provisions set forth in Sec 2.7 shall be followed to combine earthquake load effects, both horizontal and vertical, with other loading effects to obtain design forces etc.

2.5.13.4 Seismic Load Effect Including Overstrength Factor

Where specifically required, conditions requiring overstrength factor, Ω_o , applications shall be determined in accordance with the following,

1. For use in load combination 5 in Section 2.7.3 or load combinations 5 and 6 in Section 2.7.2, E shall be taken equal to E_m as determined in accordance with the following equation,

$$E_m = E_{mh} + E_v$$

2. For use in load combination 7 in Section 2.7.3 or load combination 8 in Section 2.7.2, E shall be taken equal to E_m as determined in accordance with the following equation,

$$E_m = E_{mh} - E_v$$

where

E_m = total seismic load effect including overstrength factor

E_{mh} = effect of horizontal seismic forces as defined in Sections 2.5.7 or 2.5.9 including structural overstrength.

E_v = effect of vertical seismic forces as defined in Section 2.5.13.2

The horizontal seismic load effect with overstrength factor, E_{mh} , shall be determined in accordance with the following equation:

$$E_{mh} = \Omega_o E_h$$

Where, Ω_o is the system overstrength factor as defined in Table 6.2.19. Like E_h , directional combinations as defined in Sec. 2.5.13.1.(b) is also applicable for calculating E_{mh} . The value of E_{mh} need not exceed the maximum force that can develop in the structure or element as determined by a rational, plastic mechanism analysis or nonlinear response analysis (static or dynamic) utilizing realistic expected values of material strengths.

2.5.13.5 Allowable Stress Increase for Load Combinations with Overstrength

Where allowable stress design methodologies are used with the seismic load effect defined in Section 2.5.13.4 applied in load combinations 5, 6, or 8 of Section 2.7.2, allowable stresses are permitted to be determined using an allowable stress increase of 1.2. This increase shall not be combined with increases in allowable stresses or load combination reductions otherwise permitted elsewhere by this standard.

2.5.13.6 Minimum Upward Force for Horizontal Cantilevers for Seismic Design Category D

In structures assigned to Seismic Design Category D, horizontal cantilever structural components shall be designed for a minimum net upward force of 0.2 times the dead load in addition to the applicable load combinations of Section 2.7.

2.5.14 Drift and Deformation

2.5.14.1 Storey drift limit

The design storey drift (Δ) of each storey, as determined in Sections 2.5.7, 2.5.9 or 2.5.10 shall not exceed the allowable storey drift (Δ_a) as obtained from Table 6.2.21 for any story.

For structures with significant torsional deflections, the maximum drift shall include torsional effects. For structures assigned to Seismic Design Category C or D having torsional irregularity, the design storey drift, shall be computed as the largest difference of the deflections along any of the edges of the structure at the top and bottom of the storey under consideration. For seismic force-resisting systems comprised solely of moment frames in Seismic Design Categories D, the allowable storey drift for such linear elastic analysis procedures shall not exceed Δ_a/ρ where ρ is termed as a structural redundancy factor. The value of redundancy factor ρ may be considered as 1.0 with exception of structures of very low level of redundancy where ρ may be considered as 1.3.

For nonlinear time history analysis (NTHA), the storey drift obtained (Sec 2.5.11) shall not exceed 1.25 times the storey drift limit specified above for linear elastic analysis procedures.

2.5.14.2 Diaphragm deflection

The deflection in the plane of the diaphragm, as determined by engineering analysis, shall not exceed the permissible deflection of the attached elements. Permissible deflection shall be that deflection that will permit the attached element to maintain its structural integrity under the individual loading and continue to support the prescribed loads.

Table 6.2.21: Allowable Storey Drift Limit (Δ_a)

Structure	Occupancy Category		
	I and II	III	IV
Structures, other than masonry shear wall structures, 4 stories or less with interior walls, partitions, ceilings and exterior wall systems that have been designed to accommodate the story drifts.	$0.025h_{sx}$	$0.020h_{sx}$	$0.015h_{sx}$
Masonry cantilever shear wall structures	$0.010h_{sx}$	$0.010h_{sx}$	$0.010h_{sx}$
Other masonry shear wall structures	$0.007h_{sx}$	$0.007h_{sx}$	$0.007h_{sx}$
All other structures	$0.020h_{sx}$	$0.015h_{sx}$	$0.010h_{sx}$

Notes:

1. h_{sx} is the story height below Level x .
2. There shall be no drift limit for single-story structures with interior walls, partitions, ceilings, and exterior wall systems that have been designed to accommodate the storey drifts.
3. Structures in which the basic structural system consists of masonry shear walls designed as vertical elements cantilevered from their base or foundation support which are so constructed that moment transfer between shear walls (coupling) is negligible.
4. Occupancy categories are defined in Table 6.1.1

2.5.14.3 Separation between adjacent structures

Buildings shall be protected from earthquake-induced pounding from adjacent structures or between structurally independent units of the same building maintaining safe distance between such structures as follows:

- (i) for buildings, or structurally independent units, that do not belong to the same property, the distance from the property line to the potential points of impact shall not be less than the computed maximum horizontal displacement (Sec 2.5.7.7) of the building at the corresponding level.

- (ii) for buildings, or structurally independent units, belonging to the same property, if the distance between them is not less than the square root of the sum of the squares (SRSS) of the computed maximum horizontal displacements (Sec 2.5.7.7) of the two buildings or units at the corresponding level.
- (iii) if the floor elevations of the building or independent unit under design are the same as those of the adjacent building or unit, the above referred minimum distance may be reduced by a factor of 0.7

2.5.14.4 Special deformation requirement for seismic design category D

For structures assigned to Seismic Design Category D, every structural component not included in the seismic force-resisting system in the direction under consideration shall be designed to be adequate for the gravity load effects and the seismic forces resulting from displacement to the design story drift (Δ) as determined in accordance with Sec 2.5.7.7. Even where elements of the structure are not intended to resist seismic forces, their protection may be important. Where determining the moments and shears induced in components that are not included in the seismic force-resisting system in the direction under consideration, the stiffening effects of adjoining rigid structural and nonstructural elements shall be considered and a rational value of member and restraint stiffness shall be used.

2.5.15 Seismic Design For Nonstructural Components

This Section establishes minimum design criteria for nonstructural components that are permanently attached to structures and for their supports and attachments. The following components are exempt from the requirements of this Section.

- (1) Architectural components in Seismic Design Category B, other than parapets supported by bearing walls or shear walls, where the component importance factor, I_c is equal to 1.0.
- (2) Mechanical and electrical components in Seismic Design Category B.
- (3) Mechanical and electrical components in Seismic Design Category C where the importance factor, I_c is equal to 1.0.
- (4) Mechanical and electrical components in Seismic Design Category D where the component importance factor, I_c is equal to 1.0 and either (a) flexible connections between the components and associated ductwork, piping, and conduit are provided, or (b) components are mounted at 1.2 m or less above a floor level and weigh 1780 N or less.

- (5) Mechanical and electrical components in Seismic Design Category C or D where the component importance factor, I_c is equal to 1.0 and (a) flexible connections between the components and associated ductwork, piping, and conduit are provided, and (b) the components weigh 89 N or less or, for distribution systems, which weigh 73 N/m or less.

Where the individual weight of supported components and non-building structures with periods greater than 0.06 seconds exceeds 25 percent of the total seismic weight W , the structure shall be designed considering interaction effects between the structure and the supported components.

Testing shall be permitted to be used in lieu of analysis methods outlined in this Chapter to determine the seismic capacity of components and their supports and attachments.

2.5.15.1 Component importance factor

All components shall be assigned a component importance factor. The component importance factor, I_c shall be taken as 1.5 if any of the following conditions apply:

- (1) The component is required to function after an earthquake,
- (2) The component contains hazardous materials, or
- (3) The component is in or attached to a occupancy category IV building and it is needed for continued operation of the facility.

All other components shall be assigned a component importance factor, I_c equal to 1.0.

2.5.15.2 Component force transfer

Components shall be attached such that the component forces are transferred to the structure. Component attachments that are intended to resist seismic forces shall be bolted, welded, or otherwise positively fastened without consideration of frictional resistance produced by the effects of gravity. A continuous load path of sufficient strength and stiffness between the component and the supporting structure shall be verified. Local elements of the supporting structure shall be designed for the component forces where such forces control the design of the elements or their connections. In this instance, the component forces shall be those determined in Sec 2.5.15.3, except that modifications to F_p and R_p due to anchorage conditions need not be considered. The design documents shall include sufficient information concerning the attachments to verify compliance with the requirements of these Provisions.

2.5.15.3 Seismic design force

The seismic design force, F_c , applied in the horizontal direction shall be centered at the component's center of gravity and distributed relative to the component's mass distribution and shall be determined as follows:

$$F_c = \frac{\alpha_c a_h W_c I_c}{R_c} \left(1 + 2 \frac{z}{h} \right) \quad (6.2.57)$$

Where,

$$0.75 a_h W_c I_c \leq F_c \leq 1.5 a_h W_c I_c$$

α_c = component amplification factor which varies from 1.0 to 2.5 (Table 6.2.22 or Table 6.2.23).

a_h = expected horizontal peak ground acceleration (in g) for design = 0.67ZS

W_c = weight of component

R_c = component response reduction factor which varies from 1.0 to 12.0 (Table 6.2.22 or Table 6.2.23)

z = height above the base of the point of attachment of the component, but z shall not be taken less than 0 and the value of z/h need not exceed 1.0

h = roof height of structure above the base

The force F_c shall be independently applied in at least two orthogonal horizontal directions in combination with service loads associated with the component. In addition, the component shall also be designed for a concurrent vertical force of $\pm 0.5 a_h W_c$.

Where non-seismic loads on nonstructural components exceed F_c such loads shall govern the strength design, but the seismic detailing requirements and limitations shall apply.

2.5.15.4 Seismic relative displacements

The relative seismic displacement, D_c for two connection points on the same structure A, one at a height h_x and other at height h_y , for use in component design shall be determined as follows:

$$D_c = \delta_{xA} - \delta_{yA} \quad (6.2.58)$$

D_c shall not exceed $D_{c \max}$ given by:

$$D_{c \max} = \frac{(h_x - h_y)\Delta_{aA}}{h_{sx}} \quad (6.2.59)$$

Where,

δ_{xA} = Deflection at level x of structure A

δ_{yA} = Deflection at level y of structure A

Δ_{aA} = Allowable story drift for structure A

h_x = Height (above base) of level x to which upper connection point is attached.

h_y = Height (above base) of level y to which lower connection point is attached.

h_{sx} = Story height used in the definition of the allowable drift Δ_a

For two connection points on separate structures, A and B, or separate structural systems, one at level x and the other at level y, D_c shall be determined as follows:

$$D_c = |\delta_{xA}| + |\delta_{yB}| \quad (6.2.60)$$

D_c shall not exceed $D_{c \max}$ given by:

$$D_{c \max} = \frac{h_x \Delta_{aA}}{h_{sx}} + \frac{h_y \Delta_{aB}}{h_{sx}} \quad (6.2.61)$$

Where,

δ_{yB} = Deflection at level y of structure B

Δ_{aB} = Allowable story drift for structure B

The effects of relative seismic relative displacements shall be considered in combination with displacements caused by other loads as appropriate.

2.5.16 Design For Seismically Isolated Buildings

Buildings that use special seismic isolation systems for protection against earthquakes shall be called seismically isolated or base isolated buildings. Seismically isolated structure and every portion thereof shall be designed and constructed in accordance with the requirements of provisions presented in this Section.

2.5.16.1 General requirements for isolation system

The isolation system to be used in seismically isolated structures shall satisfy the following requirements:

- (1) Design of isolation system shall consider variations in seismic isolator material properties over the projected life of structure including changes due to ageing, contamination, exposure to moisture, loadings, temperature, creep, fatigue, etc.
- (2) Isolated structures shall resist design wind loads at all levels above the isolation interface. At the isolation interface, a wind restraint system shall be provided to limit lateral displacement in the isolation system to a value equal to that required between floors of the structure above the isolation interface.
- (3) The fire resistance rating for the isolation system shall be consistent with the requirements of columns, walls, or other such elements in the same area of the structure.
- (4) The isolation system shall be configured to produce a lateral restoring force such that the lateral force at the total design displacement is at least 0.025 W greater than the lateral force at 50% of the total design displacement.
- (5) The isolation system shall not be configured to include a displacement restraint that limits lateral displacement due to the maximum considered earthquake to less than the total maximum displacement unless it is demonstrated by analysis that such engagement of restraint does not result in unsatisfactory performance of the structure.
- (6) Each element of the isolation system shall be designed to be stable under the design vertical load when subjected to a horizontal displacement equal to the total maximum displacement.
- (7) The factor of safety against global structural overturning at the isolation interface shall not be less than 1.0 for required load combinations. All gravity and seismic loading conditions shall be investigated. Seismic forces for overturning calculations shall be based on the maximum considered earthquake and the vertical restoring force shall be based on the seismic weight above the isolation interface.
- (8) Local uplift of individual units of isolation system is permitted if the resulting deflections do not cause overstress or instability of the isolator units or other elements of the structure.

- (9) Access for inspection and replacement of all components of the isolation system shall be provided.
- (10) The designer of the isolation system shall establish a quality control testing program for isolator units. Each isolator unit before installation shall be tested under specified vertical and horizontal loads.
- (11) After completion of construction, a design professional shall complete a final series of inspections or observations of structure separation areas and components that cross the isolation interface. Such inspections and observations shall confirm that existing conditions allow free and unhindered displacement of the structure to maximum design levels and that all components that cross the isolation interface as installed are able to accommodate the stipulated displacements.
- (12) The designer of the isolation system shall establish a periodic monitoring, inspection, and maintenance program for such system.
- (13) Remodeling, repair, or retrofitting at the isolation interface, including that of components that cross the isolation interface, shall be performed under the direction of a design professional experienced in seismic isolation systems.

Table 6.2.22: Coefficients α_c and R_c for Architectural Components

Architectural Component or Element	α_c^a	R_c
Interior Nonstructural Walls and Partitions		
Plain (unreinforced) masonry walls	1.0	1.5
All other walls and partitions	1.0	2.5
Cantilever Elements (Unbraced or braced to structural frame below its center of mass) Parapets and cantilever interior nonstructural walls	2.5	2.5
Chimneys and stacks where laterally braced or supported by the structural frame	2.5	2.5
Cantilever Elements (Braced to structural frame above its center of mass)		
Parapets	1.0	2.5
Chimneys and Stacks	1.0	2.5
Exterior Nonstructural Walls	1.0	2.5

Architectural Component or Element	α_c^a	R_c
Exterior Nonstructural Wall Elements and Connections		
Wall Element	1.0	2.5
Body of wall panel connections	1.0	2.5
Fasteners of the connecting system	1.25	1.0
Veneer		
Limited deformability elements and attachments	1.0	2.5
Low deformability elements and attachments	1.0	1.5
Penthouses (except where framed by an extension of the building frame)	2.5	3.5
Ceilings		
All	1.0	2.5
Cabinets		
Storage cabinets and laboratory equipment	1.0	2.5
Access Floors		
Special access floors	1.0	2.5
All other	1.0	1.5
Appendages and Ornamentations	2.5	2.5
Signs and Billboards	2.5	2.5
Other Rigid Components		
High deformability elements and attachments	1.0	3.5
Limited deformability elements and attachments	1.0	2.5
Low deformability materials and attachments	1.0	1.5
Other Flexible Components		
High deformability elements and attachments	2.5	3.5
Limited deformability elements and attachments	2.5	2.5
Low deformability materials and attachments	2.5	1.5

^a A lower value for α_c is permitted where justified by detailed dynamic analysis. The value for α_c shall not be less than 1.0. The value of α_c equal to 1.0 is for rigid components and rigidly attached components. The value of α_c equal to 2.5 is for flexible components and flexibly attached components.

Table 6.2.23: Coefficients α_c and R_c for Mechanical and Electrical Components

Mechanical and Electrical Components	α_c^a	R_c
Air-side HVAC, fans, air handlers, air conditioning units, cabinet heaters, air distribution boxes, and other mechanical components constructed of sheet metal framing.	2.5	6.0
Wet-side HVAC, boilers, furnaces, atmospheric tanks and bins, chillers, water heaters, heat exchangers, evaporators, air separators, manufacturing or process equipment, and other mechanical components constructed of high-deformability materials.	1.0	2.5
Engines, turbines, pumps, compressors, and pressure vessels not supported on skirts and not within the scope of Chapter 15.	1.0	2.5
Skirt-supported pressure vessels	2.5	2.5
Elevator and escalator components.	1.0	2.5
Generators, batteries, inverters, motors, transformers, and other electrical components constructed of high deformability materials.	1.0	2.5
Motor control centers, panel boards, switch gear, instrumentation cabinets, and other components constructed of sheet metal framing.	2.5	6.0
Communication equipment, computers, instrumentation, and controls.	1.0	2.5
Roof-mounted chimneys, stacks, cooling and electrical towers laterally braced below their center of mass.	2.5	3.0
Roof-mounted chimneys, stacks, cooling and electrical towers laterally braced above their center of mass.	1.0	2.5
Lighting fixtures.	1.0	1.5
Other mechanical or electrical components.	1.0	1.5
Vibration Isolated Components and Systems^b		
Components and systems isolated using neoprene elements and neoprene isolated floors with built-in or separate elastomeric snubbing devices or resilient perimeter stops.	2.5	2.5
Spring isolated components and systems and vibration isolated floors closely restrained using built-in or separate elastomeric snubbing devices or resilient perimeter stops.	2.5	2.0
Internally isolated components and systems.	2.5	2.0
Suspended vibration isolated equipment including in-line duct devices and suspended internally isolated components.	2.5	2.5
Mechanical and Electrical Components	α_c^a	R_c
Air-side HVAC, fans, air handlers, air conditioning units, cabinet heaters, air distribution boxes, and other mechanical components constructed of sheet metal framing.	2.5	6.0
Wet-side HVAC, boilers, furnaces, atmospheric tanks and bins, chillers, water heaters, heat exchangers, evaporators, air separators, manufacturing or process equipment, and other mechanical components constructed of high-deformability materials.	1.0	2.5

Mechanical and Electrical Components	α_c^a	R_c
Engines, turbines, pumps, compressors, and pressure vessels not supported on skirts and not within the scope of Chapter 15.	1.0	2.5
Skirt-supported pressure vessels	2.5	2.5
Distribution Systems		
Piping in accordance with ASME B31, including in-line components with joints made by welding or brazing.	2.5	12.0
Piping in accordance with ASME B31, including in-line components, constructed of high or limited deformability materials, with joints made by threading, bonding, compression couplings, or grooved couplings.	2.5	6.0
Piping and tubing not in accordance with ASME B31, including in-line components, constructed of high-deformability materials, with joints made by welding or brazing.	2.5	9.0
Piping and tubing not in accordance with ASME B31, including in-line components, constructed of high- or limited-deformability materials, with joints made by threading, bonding, compression couplings, or grooved couplings.	2.5	4.5
Piping and tubing constructed of low-deformability materials, such as cast iron, glass, and non-ductile plastics.	2.5	3.0
Ductwork, including in-line components, constructed of high-deformability materials, with joints made by welding or brazing.	2.5	9.0
Ductwork, including in-line components, constructed of high- or limited-deformability materials with joints made by means other than welding or brazing.	2.5	6.0
Ductwork, including in-line components, constructed of low-deformability materials, such as cast iron, glass, and non-ductile plastics.	2.5	3.0
Electrical conduit, bus ducts, rigidly mounted cable trays, and plumbing.	1.0	2.5
Manufacturing or process conveyors (non-personnel).	2.5	3.0
Suspended cable trays.	2.5	6.0

^a A lower value for α_c is permitted where justified by detailed dynamic analysis. The value for α_c shall not be less than 1.0. The value of α_c equal to 1.0 is for rigid components and rigidly attached components. The value of α_c equal to 2.5 is for flexible components and flexibly attached components.

^b Components mounted on vibration isolators shall have a bumper restraint or snubber in each horizontal direction. The design force shall be taken as $2F_c$ if the nominal clearance (air gap) between the equipment support frame and restraint is greater than 6 mm. If the nominal clearance specified on the construction documents is not greater than 6 mm, the design force may be taken as F_c .

2.5.16.2 Equivalent static analysis

The equivalent static analysis procedure is permitted to be used for design of a seismically isolated structure provided that:

- (1) The structure is located on Site Class SA, SB, SC, SD or SE site;
- (2) The structure above the isolation interface is not more than four stories or 20 m in height
- (3) Effective period of the isolated structure at the maximum displacement, T_M , is less than or equal to 3.0 sec.
- (4) The effective period of the isolated structure at the design displacement, T_D , is greater than three times the elastic, fixed-base period of the structure above the isolation system as determined in Sec. 2.5.7.2
- (5) The structure above the isolation system is of regular configuration; and
- (6) The isolation system meets all of the following criteria:
 - (a) The effective stiffness of the isolation system at the design displacement is greater than one third of the effective stiffness at 20 percent of the design displacement,
 - (b) The isolation system is capable of producing a restoring force as specified in Sec. 2.5.16.1,
 - (c) The isolation system does not limit maximum considered earthquake displacement to less than the total maximum displacement.

Where the equivalent lateral force procedure is used to design seismically isolated structures, the requirements of this Section shall apply.

2.5.16.2.1 Displacement of isolation system: The isolation system shall be designed and constructed to withstand minimum lateral earthquake displacements that act in the direction of each of the main horizontal axes of the structure and such displacements shall be calculated as follows:

$$D_D = \frac{S_a g}{4\pi^2} \left(\frac{T_D^2}{B_D} \right) \quad (6.2.62)$$

Where,

S_a = Design spectral acceleration (in units of g), calculated using Eq. 6.2.34 for period T_D and assuming $R=1$, $I=1$, $\eta=1$ (Sec 2.5.4.3) for the design basis earthquake (DBE).

g = acceleration due to gravity

B_D = damping coefficient related to the effective damping β_D of the isolation system at the design displacement, as set forth in Table 6.2.24.

T_D = effective period of seismically isolated structure at the design displacement in the direction under consideration, as prescribed by Eq. 6.2.63:

$$T_D = 2\pi \sqrt{\frac{W}{k_{D \min} g}} \quad (6.2.63)$$

Where,

W = seismic weight above the isolation interface

$k_{D \min}$ = minimum effective stiffness of the isolation system at the design displacement in the horizontal direction under consideration.

Table 6.2.24: Damping Coefficient, B_D or B_M

Effective Damping, β_D or β_M ^{a, b} (%)	B_D or B_M
≤ 2	0.8
5	1.0
10	1.2
20	1.5
30	1.7
40	1.9
≥ 50	2.0

^a The damping coefficient shall be based on the effective damping of the isolation system

^b The damping coefficient shall be based on linear interpolation for effective damping values other than those given.

The maximum displacement of the isolation system, D_M , in the most critical direction of horizontal response shall be calculated in accordance with the following formula:

$$D_M = \frac{S_{aM}g}{4\pi^2} \left(\frac{T_M^2}{B_M} \right) \quad (6.2.64)$$

Where:

S_{aM} = Maximum spectral acceleration (in units of g), calculated using Eq. 6.2.34 for period T_D and assuming $R=1$, $I=1$, $\eta=1$ (Sec 2.5.4.3) for the maximum considered earthquake (MCE).

B_M = numerical coefficient related to the effective damping β_M of the isolation system at the maximum displacement, as set forth in Table 6.2.24.

T_M = effective period of seismic-isolated structure at the maximum displacement in the direction under consideration as prescribed by:

$$T_M = 2\pi \sqrt{\frac{W}{k_{M \min}g}} \quad (6.2.65)$$

Where,

$k_{M \min}$ = minimum effective stiffness of the isolation system at the maximum displacement in the horizontal direction under consideration.

The total design displacement, D_{TD} , and the total maximum displacement, D_{TM} , of elements of the isolation system shall include additional displacement due to inherent and accidental torsion calculated considering the spatial distribution of the lateral stiffness of the isolation system and the most disadvantageous location of eccentric mass.

2.5.16.2.2 Lateral seismic forces: The structure above the isolation system shall be designed and constructed to withstand a minimum lateral force, V_s , using all of the appropriate provisions for a non-isolated structure. The importance factor for all isolated structures shall be considered as 1.0, also the response reduction factor R_I considered here (for computing design seismic forces) is in the range of 1.0 to 2.0. V_s shall be determined in accordance with Eq. 6.2.66 as follows:

$$V_s = \frac{k_{D \max} D_D}{R_I} \quad (6.2.66)$$

Where,

k_{Dmax} = maximum effective stiffness of the isolation system at the design displacement in the horizontal direction under consideration.

D_D = design displacement at the center of rigidity of the isolation system in the direction under consideration as prescribed by Eq. 6.2.62.

R_I = response reduction factor related to the type of seismic-force-resisting system above the isolation system. R_I shall be based on the type of seismic-force-resisting system used for the structure above the isolation system and shall be taken as the lesser of $\frac{3}{8}R$ (Table 6.2.19) or 2.0, but need not be taken less than 1.0.

In no case shall V_s be taken less than the following:

- (1) The lateral force required by Sec 2.5.7 for a fixed-base structure of the same weight, W , and a period equal to the isolated period, T_D ;
- (2) The base shear corresponding to the factored design wind load; and
- (3) The lateral force required to fully activate the isolation system (e.g., the yield level of a softening system, the ultimate capacity of a sacrificial wind-restraint system, or the break-away friction level of a sliding system) multiplied by 1.5.

The isolation system, the foundation, and all structural elements below the isolation system shall be designed and constructed to withstand a minimum lateral force, V_b using all of the appropriate provisions for a non-isolated structure. V_b shall be determined in accordance with Eq. 6.2.67 as follows:

$$V_b = k_{Dmax}D_D \quad (6.2.67)$$

In all cases, V_b shall not be taken less than the maximum force in the isolation system at any displacement up to and including the design displacement.

2.5.16.2.3 Vertical distribution of lateral forces: The total lateral force shall be distributed over the height of the structure above the isolation interface in accordance with Eq. 6.2.68 as follows:

$$F_x = V_s \frac{w_x h_x}{\sum_{i=1}^n w_i h_i} \quad (6.2.68)$$

Where:

$V_s =$ Total seismic lateral design force on elements above the isolation system.

$h_i, h_x =$ Height above the base, to Level i or Level x, respectively.

$w_i, w_x =$ Portion of W that is located at or assigned to Level i or Level x, respectively.

At each Level x the force, F_x shall be applied over the area of the structure in accordance with the distribution of mass at the level. Stresses in each structural element shall be determined by applying the lateral forces, F_x at all levels above the base to an analytical model.

2.5.16.2.4 Storey drift: The storey drift shall be calculated as in Sec 2.5.7.7 except that C_d for the isolated structure shall be taken equal to R_I and importance factor equal to 1.0. The maximum storey drift of the structure above the isolation system shall not exceed $0.015h_{sx}$.

2.5.16.3 Dynamic analysis

Response spectrum analysis may be conducted if the behavior of the isolation system can be considered as equivalent linear. Otherwise, non-linear time history analysis shall be used where the true non-linear behaviour of the isolation system can be modeled. The mathematical models of the isolated structure including the isolation system shall be along guidelines given in Sections 2.5.9.1 and 2.5.11.1, and other requirements given in Sec 2.5.16.

The isolation system shall be modeled using deformational characteristics developed and verified by testing. The structure model shall account for: (i) spatial distribution of isolator units; (ii) consideration of translation in both horizontal directions, and torsion of the structure above the isolation interface considering the most disadvantageous location of eccentric mass; (iii) overturning/uplift forces on individual isolator units; and (iv) effects of vertical load, bilateral load, and the rate of loading if the force-deflection properties of the isolation system are dependent on such attributes.

A linear elastic model of the isolated structure (above isolation system) may be used provided that: (i) stiffness properties assumed for the nonlinear components of the isolation system are based on the maximum effective stiffness of the isolation system, and (ii) all elements of the seismic-force-resisting system of the structure above the isolation system behave linearly.

2.5.16.3.1 Response Spectrum Analysis: Response spectrum analysis shall be performed using a modal damping value for the fundamental mode in the direction of interest not greater than the effective damping of the isolation system or 30 percent of critical, whichever is less. Modal damping values for higher modes shall be selected consistent with those that would be appropriate for response spectrum analysis of the structure above the isolation system assuming a fixed base.

Response spectrum analysis used to determine the total design displacement and the total maximum displacement shall include simultaneous excitation of the model by 100 percent of the ground motion in the critical direction and 30 percent of the ground motion in the perpendicular, horizontal direction. The design basis earthquake shall be used for the design displacement, while the maximum considered earthquake shall be used for the maximum displacement. The maximum displacement of the isolation system shall be calculated as the vectorial sum of the two orthogonal displacements.

For the design displacement, structures that do not require site-specific ground motion evaluation, shall be analyzed using the design acceleration response spectrum in accordance with Sec 2.5.4.3. The maximum design spectrum to be used for the maximum considered earthquake shall not be less than 1.5 times the design acceleration response spectrum.

The response spectrum procedure is based on an equivalent linear model, where the effective stiffness and effective damping is a function of the displacement, this formulation is thus an iterative process. The effective stiffness must be estimated, based on assumed displacement, and then adjusted till obtained displacement agree with assumed displacement.

The design shear at any story shall not be less than the story shear resulting from application of the story forces calculated using Eq. 6.2.68 with a value of V_s equal to the base shear obtained from the response spectrum analysis in the direction of interest.

2.5.16.3.2 Nonlinear Time History Analysis: Where a time history analysis procedure is performed, not fewer than three appropriate ground motions shall be used in the analysis as described below.

Ground motions shall consist of pairs of appropriate horizontal ground motion acceleration components that shall be selected and scaled from individual recorded events. Appropriate ground motions shall be selected from events having magnitudes, fault distance, and source mechanisms that are consistent with those that control the maximum considered earthquake. If required number of recorded ground motion pairs are not available, appropriate simulated ground motion pairs shall be used to make up the total number required. For each pair of horizontal ground-motion components, a square root of the sum of the squares (SRSS) spectrum shall be constructed by taking the SRSS of the 5 percent damped response spectra for the scaled components (where an identical scale factor is applied to both components of a pair). Each pair of motions shall be scaled such that for each period between $0.5T_D$ and $1.25T_M$ (where T_D and T_M are defined in Sec 2.5.16.2.1) the average of the SRSS spectra from all horizontal component pairs does not fall below 1.3 times the corresponding ordinate of the design response spectrum (Sec 2.5.16.4), by more than 10 percent.

Each pair of ground motion components shall be applied simultaneously to the model considering the most disadvantageous location of eccentric mass. The maximum displacement of the isolation system shall be calculated from the vectorial sum of the two orthogonal displacements at each time step.

The parameters of interest shall be calculated for each ground motion used for the time history analysis. If at least seven ground motions are used for the time history analysis, the average value of the response parameter of interest is permitted to be used for design. If fewer than seven ground motions are analyzed, the maximum value of the response parameter of interest shall be used for design.

2.5.16.3.3 Storey drift: Maximum story drift corresponding to the design lateral force including displacement due to vertical deformation of the isolation system shall not exceed the following limits:

1. The maximum story drift of the structure above the isolation system calculated by response spectrum analysis shall not exceed $0.015h_{sx}$.
2. The maximum story drift of the structure above the isolation system calculated by nonlinear time history analysis shall not exceed $0.020h_{sx}$.

The storey drift shall be calculated as in Sec 2.5.7.7 except that C_d for the isolated structure shall be taken equal to R_I and importance factor equal to 1.0.

2.5.16.4 Testing

The deformation characteristics and damping values of the isolation system used in the design and analysis of seismically isolated structures shall be based on test results of isolator units. The tests are for establishing and validating the design properties of the isolation system and shall not be considered as satisfying the manufacturing quality control tests.

The following sequence of tests shall be performed on isolator units for the prescribed number of cycles at a vertical load equal to the average dead load plus one-half the effects due to live load on all isolator units of a common type and size:

- (1) Twenty fully reversed cycles of loading at a lateral force corresponding to the wind design force.
- (2) Three fully reversed cycles of loading at each of the following increments of the total design displacement- $0.25D_D$, $0.5D_D$, $1.0D_D$, and $1.0D_M$ where D_D and D_M are as determined in Sec 2.5.16.2.1.
- (3) Three fully reversed cycles of loading at the total maximum displacement, $1.0D_{TM}$.
- (4) Not less than ten fully reversed cycles of loading at 1.0 times the total design displacement, $1.0D_{TD}$.

For each cycle of each test, the force-deflection and hysteretic behavior of each isolator unit shall be recorded. The effective stiffness is obtained as the secant value of stiffness at design displacement while the effective damping is determined from the area of hysteretic loop at the design displacement.

2.5.16.5 Design review

A design review of the isolation system and related test programs shall be performed by an independent team of design professionals experienced in seismic analysis methods and the application of seismic isolation. Isolation system design review shall include, but need not be limited to, the following:

- (1) Review of site-specific seismic criteria including the development of site-specific spectra and ground motion time histories and all other design criteria developed specifically for the project;

- (2) Review of the preliminary design including the determination of the total design displacement of the isolation system and the lateral force design level;
- (3) Overview and observation of prototype (isolator unit) testing
- (4) Review of the final design of the entire structural system and all supporting analyses; and
- (5) Review of the isolation system quality control testing program.

2.5.17 Buildings with Soft Storey

Buildings with possible soft storey action at ground level for providing open parking spaces belong to structures with major vertical irregularity [Figure 6.2.28(a)]. Special arrangement is needed to increase the lateral strength and stiffness of the soft/open storey. The following two approaches may be considered:

- (1) Dynamic analysis of such building may be carried out incorporating the strength and stiffness of infill walls and inelastic deformations in the members, particularly those in the soft storey, and the members designed accordingly.
- (2) Alternatively, when system overstrength factor, Ω_o , is not included in determining seismic load effects, the following design criteria are to be adopted after carrying out the earthquake analysis, neglecting the effect of infill walls in other storeys. Structural elements (e.g columns and beams) of the soft storey are to be designed for 2.5 times the storey shears and moments calculated under seismic loads neglecting effect of infill walls. Shear walls placed symmetrically in both directions of the building as far away from the centre of the building as feasible are to be designed exclusively for 1.5 times the lateral shear force calculated before.

2.5.18 Non-Building Structures

Calculation of seismic design forces on non-building structures (e.g. chimney, self-supported overhead water/fluid tank, silo, trussed tower, storage tank, cooling tower, monument and other structures not covered in Sec 2.5) shall be in accordance with "Chapter 15: Seismic Design Requirements for Non-Building Structures, Minimum Design Loads for Buildings and Other Structures, ASCE Standard ASCE/SEI 7-05" complying with the requirements of Sec 2.5 of this Code.

2.6 Miscellaneous Loads

2.6.1 General

The procedures and limitations for the determination of selected miscellaneous loads are provided in this Section. Loads that are not specified in this Section or elsewhere in this Chapter, may be determined based on information from reliable references or specialist advice may be sought.

2.6.2 Rain Loads

Rain loads shall be determined in accordance with the following provisions.

2.6.2.1 Blocked drains

Each portion of a roof shall be designed to sustain the load from all rainwater that could be accumulated on it if the primary drainage system for that portion is undersized or blocked. Ponding instability shall be considered in this situation.

2.6.2.2 Controlled drainage

Roofs equipped with controlled drainage provisions shall be designed to sustain all rainwater loads on them to the elevation of the secondary drainage system plus 0.25 kN/m². Ponding instability shall be considered in this situation.

2.6.3 Loads Due to Flood and Surge

For the determination of flood and surge loads on a structural member, consideration shall be given to both hydrostatic and hydrodynamic effects. Required loading shall be determined in accordance with the established principles of mechanics based on site specific criteria and in compliance with the following provisions of this Section. For essential facilities like cyclone and flood shelters and for hazardous facilities specified in Table 6.1.1, values of maximum flood elevation, surge height, wind velocities etc., required for the determination of flood and surge load, shall be taken corresponding to 100-year return period. For structures other than essential and hazardous facilities, these values shall be based on 50-year return period.

2.6.3.1 Flood loads on structures at inland areas

For structures sited at inland areas subject to flood, loads due to flood shall be determined considering hydrostatic effects which shall be calculated based on the flood elevation of 50-year return period. For river-side structures such as that under Exposure C specified in Sec 2.4.6.3, hydrodynamic forces, arising due to approaching wind-generated waves shall also be determined in addition to the hydrostatic load on them. In this case, the amplitude of such wind-induced water waves shall be obtained from site-specific data.

2.6.3.2 Flood and surge loads on structures at coastal areas

Coastal area of Bangladesh has been delineated as Risk Area (RA) and High Risk Area (HRA) based on the possible extend of the inland intrusion of the cyclone storm surge as shown in Figure 6.2.30. To be classified as coastal RISK AREA, the principal source of flooding must be sea tides, storm surge, and not riverine flood. The RA extends from the coast line to an inland limit up to which surge water can reach. The HRA includes a strip of land within the RA. It extends from the coast line up to the limit where the depth of storm surge inundation may exceed 1m. Entire area of the off-shore islands except the Maheshkhali area is included in the HRA. A part of Maheshkhali is covered by hills and therefore free from inundation. However, the western and northern parts of Maheshkhali are of low elevation and risk inundation. For structures sited in coastal areas (Risk Areas), the hydrostatic and hydrodynamic loads shall be determined as follows:

2.6.3.2.1 Hydrostatic Loads

The hydrostatic loads on structural elements and foundations shall be determined based on the maximum static height of water, H_m , produced by floods or surges as given by the relation:

$$H_m = \max(h_s, h_f) \quad (6.2.69)$$

$$h_f = y_T - y_g \quad (6.2.70)$$

Where,

h_s = Maximum surge height as specified in (i) below.

y_T = Elevation of the extreme surface water level corresponding to a T -year return period specified in (ii) below, meters

y_g = Elevation of ground level at site, meters.

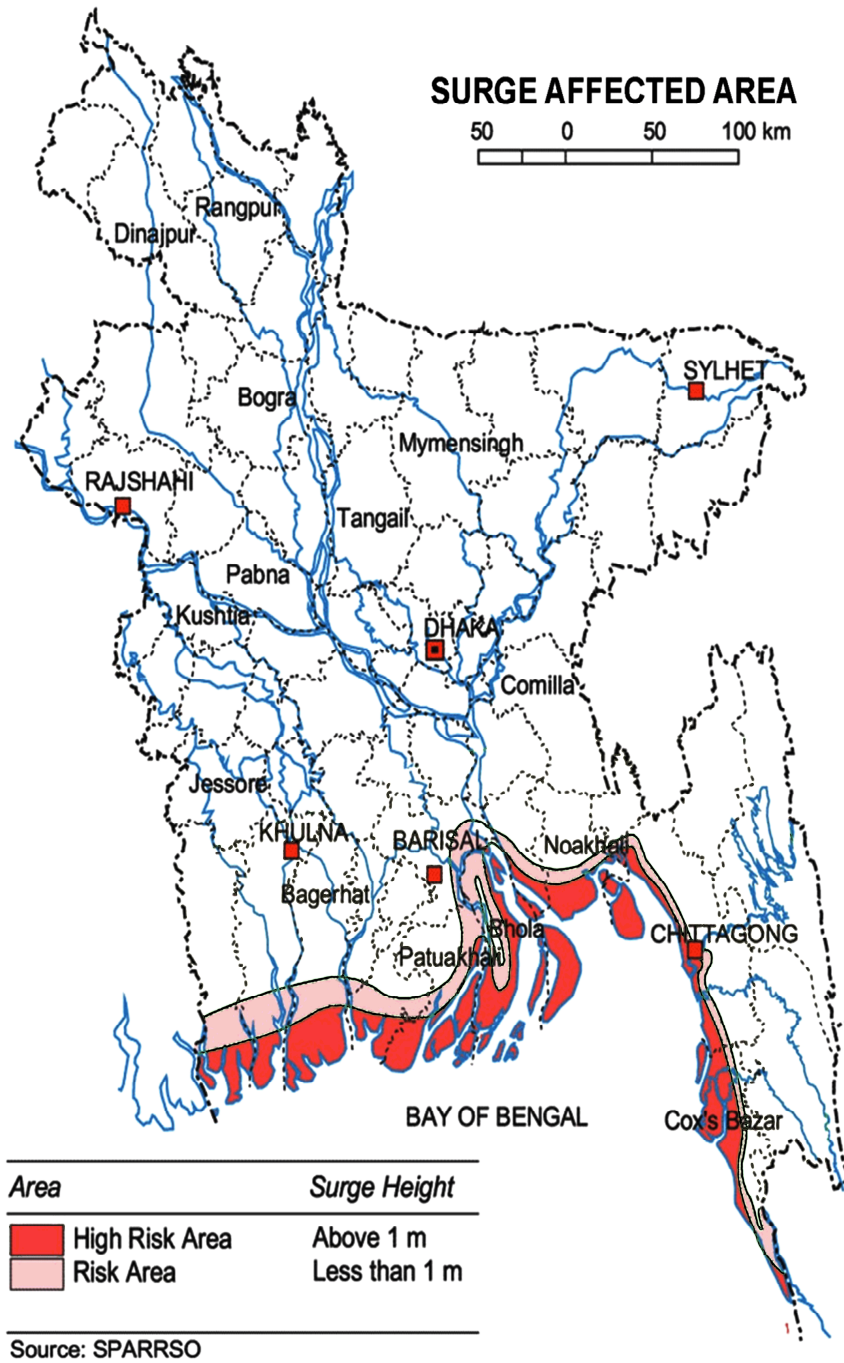


Figure 6.2.30 Coastal risk areas (RA) and high risk areas (HRA) of Bangladesh

- (i) Maximum Surge Height, h_s : The maximum surge height, h_s , associated with cyclones, shall be that corresponding to a 50-year or a 100-year return period as may be applicable, based on site specific analysis. In the absence of a more rigorous site specific analysis, the following relation may be used:

$$h_s = h_T - (x - 1)k \quad (6.2.71)$$

Where, h_T = design surge height corresponding to a return period of T -years at sea coast, in metres, given in Table 6.2.25.

x = distance of the structure site measured from the spring tide high-water limit on the sea coast, in km; $x= 1$, if $x < 1$.

k = rate of decrease in surge height in meter/km; the value of k may be taken as 0.5 for Chittagong-Cox's Bazar-Teknaf coast and as 0.33 for other coastal areas.

- (ii) Extreme Surface Water Level, y_T : The elevation of the extreme surface water level, y_T for a site, which may not be associated with a cyclonic storm surge, shall be that obtained from a site specific analysis corresponding to a 50-year or a 100-year return period. Values of y_T are given in Table 6.2.26 for selected coastal locations which may be used in the absence of any site specific data.

Hydrostatic loads caused by a depth of water to the level of the H_m shall be applied over all surfaces involved, both above and below ground level, except that for surfaces exposed to free water, the design depth H_m shall be increased by 0.30 m. Reduced uplift and lateral loads on surfaces of enclosed spaces below the H_m shall apply only if provision is made for entry and exit of floodwater.

Table 6.2.25: Design Surge Heights at the Sea Coast, h_T^*

Coastal Region	Surge Height at the Sea Coast, h_T (m)	
	$T = 50\text{-year}^{(1)}$	$T = 100\text{-year}^{(2)}$
Teknaf to Cox's Bazar	4.5	5.8
Chakaria to Anwara, and Maheshkhali-Kutubdia Islands	7.1	8.6
Chittagong to Noakhali	7.9	9.6
Sandwip, Hatiya and all islands in this region	7.9	9.6
Bhola to Barguna	6.2	7.7
Sarankhola to Shyamnagar	5.3	6.4

Notes:

* Values prepared from information obtained from Annex-D3, MCSP.

(1) These values may be used in the absence of site specific data for structures other than essential facilities listed in Table 6.1.1.

(2) These values may be used in the absence of site specific data for essential facilities listed in Table 6.1.1.

Table 6.2.26: Extreme Surface Water Levels above PWD Datum, y_T^* at Coastal Areas during Monsoon

Coastal Area		y_T (m)	
Location	Thana	T = 50 years ⁽¹⁾	T = 100 years ⁽²⁾
Teknaf	Teknaf	2.33	2.44
Cox's Bazar	Cox's Bazar	3.84	3.88
Shaflapur	Moheshkhali	4.67	4.87
Lemsikhali	Kutubdia	4.95	5.19
Banigram	Patiya	5.05	5.24
Chittagong	Bandar	4.72	4.88
Patenga	Bandar	4.08	4.16
Sonapur	Sonagazi	7.02	7.11
Sandwip	Sandwip	6.09	6.2
Companyganj	Companyganj	7.53	7.94
Hatiya	Hatiya	5.55	5.76
Daulatkhan	Daulatkhan	4.62	4.72
Dashmina	Dashmina	3.60	3.73
Galachipa	Galachipa	3.79	3.92
Patuakhali	Patuakhali	2.87	3.03
Khepupara	Kalapara	2.93	3.02
Bamna	Bamna	3.32	3.37
Patharghata	Patharghata	3.65	3.84
Raenda	Sarankhola	3.66	3.75
Chardouni	Patharghata	4.41	4.66
Mongla	Mongla port	3.23	3.36
Kobodak (river estuary)	Shyamnagar	3.51	3.87
Kaikhali	Shyamnagar	3.94	4.12

Notes:

- * Values prepared from information obtained from Annex -D3, MCSP
- (1) These values may be used in the absence of site specific data for structures in Structure Occupancy Category IV listed Table 6.1.1.
- (2) These values may be used in the absence of site specific data for structures in Structure Occupancy Categories I, II and III listed in Table 6.1.1.

2.6.3.2.2 Hydrodynamic loads

The hydrodynamic load applied on a structural element due to wind-induced local waves of water, shall be determined by a rational analysis using an established method of fluid mechanics and based on site specific data. In the absence of a site-specific data the amplitude of the local wave, to be used in the rational analysis, shall be taken as $h_w = \frac{h_s}{4} \geq 1$ m, where, h_s is given in Sec 2.6.3.2.1. Such forces shall be calculated based on 50-year or 100-year return period of flood or surge. The corresponding wind velocities shall be 80 m/s or 90 m/s (3-sec gust) respectively.

Exception:

Where water velocities do not exceed 3.0 m/s, dynamic effects of moving water shall be permitted to be converted into equivalent hydrostatic loads by increasing H_m for design purposes by an equivalent surcharge depth, d_h , on the headwater side and above the ground level only, equal to

$$d_h = \frac{aV^2}{2g} \quad (6.2.72)$$

Where,

V = average velocity of water in m/s

g = acceleration due to gravity, 9.81 m/s²

a = coefficient of drag or shape factor (not less than 1.25)

In absence of more authentic site specific data, the velocity of water, V , may be estimated such that $d_s \leq V \leq \sqrt{gd_s}$ where g is the acceleration due to gravity and d_s is defined in Sec 2.6.3.4. Selection of the correct value of drag-coefficient a in Eq. 6.2.72 will depend upon the shape and roughness of the object exposed to flood flow, as well as the flow condition. As a general rule, the smoother and more streamlined the object, the lower the drag coefficient (shape factor). Drag coefficients for elements common in buildings and structures (round or square piles, columns, and rectangular shapes) will range from approximately 1.0 to 2.0, depending upon flow

conditions. However, given the uncertainty surrounding flow conditions at a particular site, it is recommended that a minimum value of 1.25 be used. Fluid mechanics texts should be consulted for more information on when to apply drag coefficients above 1.25.

The equivalent surcharge depth, d_n , shall be added to the design depth H_m and the resultant hydrostatic pressures applied to, and uniformly distributed across, the vertical projected area of the building or structure that is perpendicular to the flow. Surfaces parallel to the flow or surfaces wetted by the tail water shall be subject to the hydrostatic pressures for depths to the H_m only.

2.6.3.3 Breakaway walls

Walls and partitions required to break away, including their connections to the structure, shall be designed for the largest of the following loads acting perpendicular to the plane of the wall:

- (i) The wind load specified in Sec. 2.4.
- (ii) The earthquake load specified in Sec. 2.5.
- (iii) 0.50 kN/m² pressure.

The loading at which breakaway walls are intended to collapse shall not exceed 1.0 kN/m² unless the design meets the following conditions:

- (i) Breakaway wall collapse is designed to result from a flood load less than that which occurs during the base flood.
- (ii) The supporting foundation and the elevated portion of the building shall be designed against collapse, permanent lateral displacement, and other structural damage due to the effects of flood loads in combination with other loads as specified elsewhere in this Chapter.

2.6.3.4 Wave loads

Wave loads shall be determined by one of the following three methods: (1) by using the analytical procedures outlined in this Section, (2) by more advanced numerical modeling procedures, or (3) by laboratory test procedures (physical modeling).

Wave loads are those loads that result from water waves propagating over the water surface and striking a building or other structure. Design and construction of buildings and other structures subject to wave loads shall account for the following loads: a) waves breaking on any portion of the building or structure; b) uplift forces caused by shoaling waves beneath a building or structure, or portion thereof; c) wave runup striking any portion of the building or structure; d) wave-induced drag and

inertia forces; and e) wave-induced scour at the base of a building or structure, or its foundation. Nonbreaking and broken wave loads shall be calculated using the procedures described in Sections 2.6.3.2.1 and 2.6.3.2.2 that show how to calculate hydrostatic and hydrodynamic loads.

Breaking wave loads shall be calculated using the procedures described in Sections 2.6.3.4.1 to 2.6.3.4.4. Breaking wave heights used in the procedures described in these Sections shall be calculated for using Equations 6.2.73 and 6.2.74.

$$H_b = 0.78 d_s \quad (6.2.73)$$

Where,

H_b = breaking wave height in meter.

d_s = local still water depth in meter.

The local still water depth shall be calculated using Eq. 6.2.74 unless more advanced procedures or laboratory tests permitted by this Section are used.

$$d_s = 0.65H_m \quad (6.2.74)$$

2.6.3.4.1 Breaking wave loads on vertical pilings and columns

The net force resulting from a breaking wave acting on a rigid vertical pile or column shall be assumed to act at the still water elevation and shall be calculated by the following:

$$F_D = 0.5\gamma_w C_D D H_b^2 \quad (6.2.75)$$

Where,

F_D = net wave force, in kN.

γ_w = unit weight of water, in $\text{kN/m}^3 = 9.80 \text{ kN/m}^3$ for fresh water and 10.05 kN/m^3 or salt water.

C_D = coefficient of drag for breaking waves, = 1.75 for round piles or columns, and = 2.25 for square piles or columns.

D = pile or column diameter, in meter for circular sections, or for a square pile or column, 1.4 times the width of the pile or column in meter.

H_b = breaking wave height, in meter.

2.6.3.4.2 Breaking wave loads on vertical walls

Maximum pressures and net forces resulting from a normally incident breaking wave (depth-limited in size, with $H_b = 0.78d_s$ acting on a rigid vertical wall shall be calculated by the following:

$$P_{max} = C_p \gamma_w d_s + 1.2 \gamma_w d_s \quad (6.2.76)$$

$$F_t = 1.1 C_p \gamma_w d_s^2 + 2.4 \gamma_w d_s^2 \quad (6.2.77)$$

Where,

P_{max} = maximum combined dynamic ($C_p \gamma_w d_s$) and static ($1.2 \gamma_w d_s$) wave pressures, also referred to as shock pressures in kN/m².

F_t = net breaking wave force per unit length of structure, also referred to as shock, impulse, or wave impact force in kN/m, acting near the still water elevation.

C_p = dynamic pressure coefficient. It shall be taken as 1.6, 2.8, 3.2 or 3.5 for building occupancy categories I, II, III or IV respectively.

γ_w = unit weight of water, in kN/m³ = 9.80 kN/m³ for fresh water and 10.05 kN/m³ for salt water

d_s = still water depth in meter at base of building or other structure where the wave breaks.

This procedure assumes the vertical wall causes a reflected or standing wave against the water ward side of the wall with the crest of the wave at a height of $1.2d_s$ above the still water level. Thus, the dynamic static and total pressure distributions against the wall are as shown in Figure 6.2.31.

This procedure also assumes the space behind the vertical wall is dry, with no fluid balancing the static component of the wave force on the outside of the wall. If free water exists behind the wall, a portion of the hydrostatic component of the wave pressure and force disappears (Figure 6.2.32) and the net force shall be computed by Eq. 6.2.78 (the maximum combined wave pressure is still computed with Eq. 6.2.76).

$$F_t = 1.1 C_p \gamma_w d_s^2 + 1.9 \gamma_w d_s^2 \quad (6.2.78)$$

Where,

- F_t = net breaking wave force per unit length of structure, also referred to as shock, impulse, or wave impact force in kN/m, acting near the still water elevation.
- C_p = dynamic pressure coefficient. It shall be taken as 1.6, 2.8, 3.2 or 3.5 for building occupancy categories I, II, III or IV respectively.
- γ_w = unit weight of water, in kN/m³ = 9.80 kN/m³ for fresh water and 10.05 kN/m³ for salt water
- d_s = still water depth in meter at base of building or other structure where the wave breaks.

2.6.3.4.3 Breaking wave loads on nonvertical walls

Breaking wave forces given by Equations 6.2.77 and 6.2.78 shall be modified in instances where the walls or surfaces upon which the breaking waves act are nonvertical. The horizontal component of breaking wave force shall be given by

$$F_{nv} = F_t \sin^2 \alpha \quad (6.2.79)$$

Where,

- F_{nv} = horizontal component of breaking wave force in kN/m.
- F_t = net breaking wave force acting on a vertical surface in kN/m.
- α = vertical angle between nonvertical surface and the horizontal.

2.6.3.4.4 Breaking Wave Loads from Obliquely Incident Waves.

Breaking wave forces given by Equations 6.2.77 and 6.2.78 shall be modified in instances where waves are obliquely incident. Breaking wave forces from non-normally incident waves shall be given by

$$F_{oi} = F_t \sin^2 \alpha \quad (6.2.80)$$

Where,

- F_{oi} = horizontal component of obliquely incident breaking wave force in kN/m.
- F_t = net breaking wave force (normally incident waves) acting on a vertical surface in kN/m.
- α = horizontal angle between the direction of wave approach and the vertical surface.

2.6.3.5 Impact loads

Impact loads are those that result from debris, ice, and any object transported by floodwaters striking against buildings and structures, or parts thereof. Impact loads shall be determined using a rational approach as concentrated loads acting horizontally at the most critical location at or below H_m (Eq. 6.2.69). Eq. 6.2.81 provides a rational approach for calculating the magnitude of the impact load.

$$F = \frac{\pi W V_b C_I C_O C_D C_B R_{max}}{2g\Delta t} \quad (6.2.81)$$

Where,

F = impact force in N

W = debris weight in N, to be taken equal to 4448 N unless more specific data is available.

V_b = velocity of the debris, m/s, assumed equal to the velocity of water V defined in Sec. 2.6.3.2.2.

g = acceleration due to gravity, 9.81 m/s²

Δt = duration of impact, which may be taken as 0.03 second

C_I = importance co-efficient = 0.6, 1.0, 1.2 or 1.3 for building occupancy categories I, II, III or IV respectively

C_O = orientation co-efficient = 0.8

C_D = depth co-efficient, to be taken equal to 0.0 for water depth 0.3m or less and equal to 1.0 for water depth 1.5m or more. Linear interpolation shall be made for intermediate water depth values.

C_B = blockage co-efficient, to be taken equal to 0.0 for upstream flow channel width 1.5m or less and equal to 1.0 for upstream flow channel width 9.1 m or more. Linear interpolation shall be made for intermediate values of upstream flow channel width. The upstream shall extend 30.0 m from the building.

R_{max} = maximum response ratio for impulsive load (half sine wave type) to be obtained from Table 6.2.27.

2.6.4 Temperature Effects

Temperature effects, if significant, shall be considered in the design of structures or components thereof in accordance with the provision of this Section. In determining the temperature effects on a structure, the following provisions shall be considered:

- (a) The temperatures indicated, shall be the air temperature in the shade. The range of the variation in temperature for a building site shall be taken into consideration.
- (b) Effects of the variation of temperature within the material of a structural element shall be accounted for by one of the following methods.
 - (i) Relieve the stresses by providing adequate numbers of expansion or contraction joints,
 - (ii) Design the structural element to sustain additional stresses due to temperature effects.
- (c) when the method b(ii) above is considered to be applicable, the structural analysis shall take into account the following :
 - (i) The variation in temperature within the material of the structural element, exposure condition of the element and the rate at which the material absorb or radiate heat.
 - (ii) The warping or any other distortion caused due to temperature changes and temperature gradient in the structural element.
- (d) When it can be demonstrated by established principle of mechanics or by any other means that neglecting some or all of the effects of temperature, does not affect the safety and serviceability of the structure, the temperature effect can be considered insignificant and need not be considered in design.

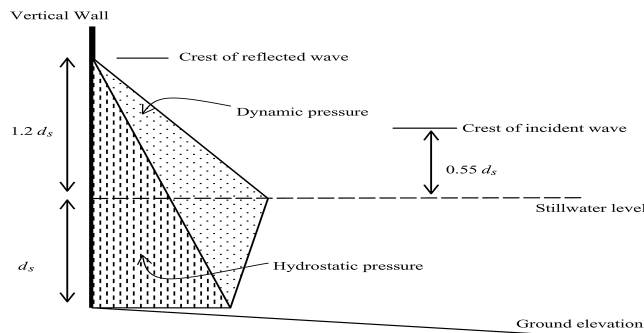


Figure 6.2.31 Normally incident breaking wave pressures against a vertical wall (space behind vertical wall is dry)

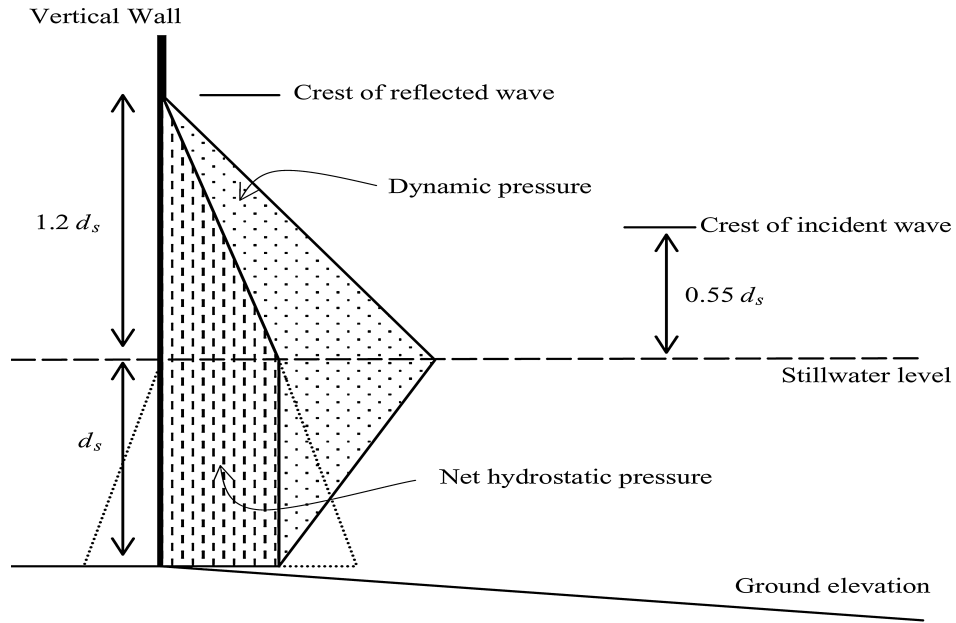


Figure 6.2.32 Normally incident breaking wave pressures against a vertical wall (still water level equal on both sides of wall)

Table 6.2.27: Values of response ratio, R_{max} , for impulsive loads

Ratio of impulse duration (Δt) to natural period (Sec. 2.5) of structure	R_{max}	Ratio of impulse duration (Δt) to natural period (Sec. 2.5) of structure	R_{max}
0	0	0.8	1.8
0.1	0.4	0.9	1.8
0.2	0.8	1	1.7
0.3	1.1	1.1	1.7
0.4	1.4	1.2	1.6
0.5	1.5	1.3	1.6
0.6	1.7	≥ 1.4	1.5
0.7	1.8		

2.6.5 Soil and Hydrostatic Pressure

For structures or portions thereof, lying below ground level, loads due to soil and hydrostatic pressure shall be determined in accordance with the provisions of this Section and applied in addition to all other applicable loads.

2.6.5.1 Pressure on basement wall:

In the design of basement walls and similar vertical or nearly vertical structures below grade, provision shall be made for the lateral pressure of adjacent soil. Allowance shall be made for possible surcharge due to fixed or moving loads. When a portion or the whole of the adjacent soil is below the surrounding water table, computations shall be based on the submerged unit weight of soil, plus full hydrostatic pressure.

2.6.5.2 Uplift on floors:

In the design of basement floors and similar horizontal or nearly horizontal construction below grade, the upward pressure of water, if any, shall be taken as the full hydrostatic pressure applied over the entire area. The hydrostatic head shall be measured from the underside of the construction.

2.6.6 Loads due to Explosions

Loads on buildings or portions thereof, shall be assessed in accordance with the provisions of this Section.

2.6.6.1 Explosion effects in closed rooms

- (a) Determination of Loads and Response: Internal overpressure developed from an internal explosion such as that due to leaks in gas pipes, evaporation of volatile liquids, internal dust explosion etc., in rooms of sizes comparable to residential rooms and with ventilation areas consisting of window glass breaking at a pressure of 4 kN/m² (3-4 mm machine made glass) may be calculated from the following method :
- (i) The overpressure, q_0 provided in Figure 6.2.33(a) shall be assumed to depend on a factor A_0/v , where, A_0 is the total window area in m² and v is the volume in m³ of the room considered,
 - (ii) The internal pressure shall be assumed to act simultaneously upon all walls and floors in one closed room, and
 - (iii) The action q_0 obtained from Figure 6.2.33(a) may be taken as static action.

When a time dependent response is required, an impulsive force function similar to that shown in Figure 6.2.33(b) shall be used in a dynamic analysis, where t_1 is the time from the start of combustion until maximum pressure is reached and t_2 is the time from maximum pressure to the end of combustion. For t_1 and t_2 the most unfavourable values shall be chosen in relation to the dynamic properties of the structures. However, the values shall be chosen within the intervals as given in Figure 6.2.33(b).

The pressure may be applied solely in one room or in more than one room at the same time. In the latter case, all rooms are incorporated in the volume v . Only windows or other similarly weak and light weight structural elements may be taken as ventilation areas even though certain limited structural parts break at pressures less than q_o .

- (b) Limitations : Procedure for determining explosion loads given in (a) above shall have the following limitations:
- (i) Values of q_o given in Figure 6.2.33(a) are based on tests with gas explosions in room corresponding to ordinary residential flats, and may be applied to considerably different conditions with caution after appropriate adjustment of the values based on more accurate information.
 - (ii) Figures 6.2.33(a) and 6.2.33(b) shall be taken as guides only, and probability of occurrence of an explosion shall be checked in each case using appropriate values.

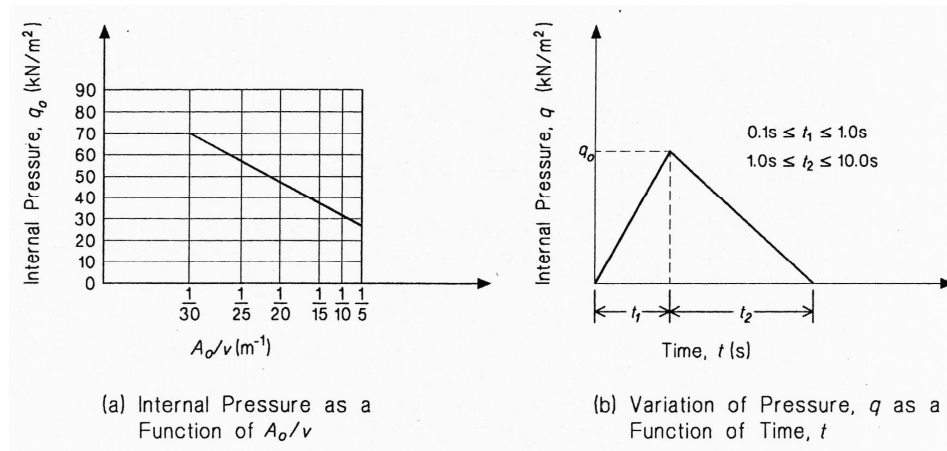


Figure 6.2.33 Magnitude and distribution of internal pressure in a building due to internal gas explosion

2.6.6.2 Minimum design pressure

Walls, floors and roofs and their supporting members separating a use from an explosion exposure, shall be designed to sustain the anticipated maximum load effects resulting from such use including any dynamic effects, but for a minimum internal pressure or suction of 5 kN/m², in addition to all other loads specified in this Chapter.

2.6.6.3 Design pressure on relief vents

When pressure-relief vents are used, such vents shall be designed to relieve at a maximum internal pressure of 1.0 kN/m².

2.6.6.4 Loads due to other explosions

Loads arising from other types of explosions, such as those from external gas cloud explosions, external explosions due to high explosives (TNT) etc. shall be determined, for specific cases, by rational analyses based on information from reliable references or specialist advice shall be sought.

2.6.7 Vertical Forces on Air Raid Shelters

For the design of air raid shelters located in a building e.g. in the basement below ground level, the characteristic vertical load shall be determined in accordance with provisions of Sec 2.6.7.1 below.

2.6.7.1 Characteristic vertical loads

Buildings in which the individual floors are acted upon by a total distributed live load of up to 5.0 kN/m², vertical forces on air raid shelters generally located below ground level, such as a basement, shall be considered to have the characteristic values provided in Table 6.2.27. In the case of buildings having floors that are acted upon by a live load larger than 5.0 kN/m², above values shall be increased by the difference between the average live loads on all storeys above the one used as the shelter and 5.0 kN/m².

Table 6.2.28: Characteristic Vertical Loads for an Air Raid Shelter in a Building

No. of Storeys ⁽¹⁾ above the Air Raid Shelter	Vertical Load, kN/m ²
≤ 2	28
3 - 4	34
≥ 4	41
Buildings of particularly stable construction irrespective of the number of storeys	28 ⁽²⁾

Notes:

⁽¹⁾ Storeys shall mean every usable storey above the shelter floor

⁽²⁾ Buildings of particularly stable construction shall mean buildings having bearing structural elements made from reinforced in-situ concrete.

2.6.8 Loads on Helicopter Landing Areas

In addition to all other applicable loads provided in this Chapter, including the dead load, the minimum live load on helicopter landing or touch down areas shall be one of the loads L_1 , L_2 or L_3 as given below producing the most unfavourable effect:

$$L_1 = W_1 \quad (6.2.82a)$$

$$L_2 = kW_2 \quad (6.2.82b)$$

$$L_3 = w \quad (6.2.82c)$$

Where,

W_1 = Actual weight of the helicopter in kN,

W_2 = Fully loaded weight of the helicopter in kN,

w = A distributed load of 5.0 kN/m²,

k = 0.75 for helicopters equipped with hydraulic - type shock absorbers,
and

= 1.5 for helicopters with rigid or skid-type landing gear.

The live load, L_1 shall be applied over the actual areas of contact of landing. The load, L_2 shall be a single concentrated load including impact applied over a 300 mm x 300 mm area. The loads L_1 and L_2 may be applied anywhere within the landing area to produce the most unfavourable effects of load.

2.6.9 Erection and Construction Loads

All loads required to be sustained by a structure or any portion thereof due to placing or storage of construction materials and erection equipment including those due to operation of such equipment shall be considered as erection loads. Provisions shall be made in design to account for all stresses due to such loads.

2.7 Combinations of Loads

2.7.1 General

Buildings, foundations and structural members shall be investigated for adequate strength to resist the most unfavorable effect resulting from the various combinations of loads provided in this Section. The combination of loads may be selected using the provisions of either Sec 2.7.2 or Sec 2.7.3 whichever is applicable. However, once Sec 2.7.2 or Sec 2.7.3 is selected for a particular construction material, it must be used exclusively for proportioning elements of that material throughout the structure.

In addition to the load combinations given in Sections 2.7.2 and 2.7.3 any other specific load combination provided elsewhere in this Code shall also be investigated to determine the most unfavourable effect.

The most unfavourable effect of loads may also occur when one or more of the contributing loads are absent, or act in the reverse direction. Loads such as F , H or S shall be considered in design when their effects are significant. Floor live loads shall not be considered where their inclusion results in lower stresses in the member under consideration. The most unfavourable effects from both wind and earthquake loads shall be considered where appropriate, but they need not be assumed to act simultaneously.

2.7.2 Combinations of Load effects for Allowable Stress/Strength Design Method

2.7.2.1 Basic combinations

Provisions of this Section shall apply to all construction materials permitting their use in proportioning structural members by allowable stress/strength design method. When this method is used in designing structural members, all loads listed herein shall be considered to act in the following combinations. The combination that produces the most unfavorable effect shall be used in design.

1. $D + F$
2. $D + H + F + L + T$
3. $D + H + F + (L_r \text{ or } R)$
4. $D + H + F + 0.75(L + T) + (L_r \text{ or } R)$
5. $D + H + F + (W \text{ or } 0.7E)$
6. $D + H + F + 0.75(W \text{ or } 0.7E) + 0.75L + 0.75(L_r \text{ or } R)$
7. $0.6D + W + H$
8. $0.6D + 0.7E + H$

When a structure is located in a flood zone or in tidal surge zone, the following load combinations shall be considered:

1. In Coastal Zones vulnerable to tidal surges, $1.5F_a$ shall be added to other loads in combinations (5), (6); E shall be set equal to zero in (5) and (6).
2. In non-coastal Zones, $0.75F_a$ shall be added to combinations (5), (6) and (7); E shall be set equal to zero in (5) and (6).

2.7.2.2 Stress increase

Unless permitted elsewhere in this Code, increases in allowable stress shall not be used with the loads or load combinations given above in Sec 2.7.2.1.

2.7.3 Combinations of Load effects for Strength Design Method

When strength design method is used, structural members and foundations shall be designed to have strength not less than that required to resist the most unfavorable effect of the combinations of factored loads listed in the following Sections:

2.7.3.1 Basic combinations

1. $1.4(D + F)$
2. $1.2(D + F + T) + 1.6(L + H) + 0.5(L_r \text{ or } R)$
3. $1.2D + 1.6(L_r \text{ or } R) + (L \text{ or } 0.8W)$
4. $1.2D + 1.6W + L + 0.5(L_r \text{ or } R)$
5. $1.2D + 1.0E + 1.0L$
6. $0.9D + 1.6W + 1.6H$
7. $0.9D + 1.0E + 1.6H$

Each relevant strength limit state shall be investigated. Effects of one or more loads not acting shall be investigated. The most unfavorable effect from both wind and earthquake loads shall be investigated, where appropriate, but they need not be considered to act simultaneously.

Exceptions:

1. The load factor on live load L in combinations (3), (4), and (5) is permitted to be reduced to 0.5 for all occupancies in which minimum specified uniformly distributed live load is less than or equal to 5.0 kN/m², with the exception of garages or areas occupied as places of public assembly.
2. The load factor on H shall be set equal to zero in combinations (6) and (7) if the structural action due to H counteracts that due to W or E . Where lateral earth pressure provides resistance to structural actions from other forces, it shall not be included in H but shall be included in the design resistance.
3. For structures designed in accordance with the provisions of Chapter 6, Part 6 of this Code (reinforced concrete structures), where wind load W has not been reduced by a directionality factor, it shall be permitted to use $1.3W$ in place of $1.6W$ in (4) and (6) above.

When a structure is located in a flood zone or in tidal surge zone, the following load combinations shall be considered:

1. In Coastal Zones vulnerable to tidal surges, $1.6W$ shall be replaced by $1.6W+2.0F_a$ in combinations (4) and (6).
2. In Non-coastal Zones, $1.6W$ shall be replaced by $0.8W+1.0F_a$ in combinations (4) and (6).

2.7.4 Load Combinations for Extraordinary Events

Where required by the applicable Code, standard, or the authority having jurisdiction, strength and stability shall be checked to ensure that structures are capable of withstanding the effects of extraordinary (i.e., low-probability) events, such as fires, explosions, and vehicular impact.

2.7.5 Load Combination for Serviceability

Serviceability limit states of buildings and structures shall be checked for the load combinations set forth in this Section as well as mentioned elsewhere in this Code. For serviceability limit states involving visually objectionable deformations, repairable cracking or other damage to interior finishes, and other short term effects, the suggested load combinations for checking vertical deflection due to gravity load is

1. $D + L$

For serviceability limit states involving creep, settlement, or similar long-term or permanent effects, the suggested load combination is:

2. $D + 0.5L$

The dead load effect, D , used in applying combinations 1 and 2 above may be that portion of dead load that occurs following attachment of nonstructural elements. In applying combination 2 above to account for long term creep effect, the immediate (e.g. elastic) deflection may be multiplied by a creep factor ranging from 1.5 to 2.0. Serviceability against gravity loads (vertical deflections) shall be checked against the limits set forth in Sec 1.2.5 Chapter 1 of this Part as well as mentioned elsewhere in this Code.

For serviceability limit state against lateral deflection of buildings and structures due to wind effect, the following combination shall be used:

3. $D + 0.5L + 0.7W$

Due to its transient nature, wind load need not be considered in analyzing the effects of creep or other long-term actions. Serviceability against wind load using load combination 3 above shall be checked in accordance with the limit set forth in Sec 1.5.6.2 Chapter 1 of this Part.

2.8 List of Related Appendices

- | | |
|------------|---|
| Appendix A | Equivalence of Nonhomogenous Equations in SI-Metric, MKS-Metric, and U.S. Customary Units |
| Appendix B | Local Geology, Tectonic Features and Earthquake Occurrence in the Region |
| Appendix C | Seismic Design Parameters for Alternative Method of Base Shear Calculation |

PART VI
Chapter 3
Soils And Foundations

3.1 General

The Soils and Foundations Chapter of the Code is divided into the following three distinct Divisions:

Division A: Site Investigations, Soil Classifications, Materials and Foundation Types

Division B: Service Load Design Method of Foundations

Division C: Additional Considerations in Planning, Design and Construction of Building Foundations

Division A (Site Investigations, Soil Classifications, Materials and Foundation Types) consists of the following Sections:

- Site Investigations
- Identification, Classification and Description of Soils
- Materials
- Types of Foundation

Division B (Service Load Design Method of Foundations) has the sections as under:

- Shallow Foundations
- Geotechnical Design of Shallow Foundations
- Geotechnical Design of Deep Foundations
- Field Tests for Driven Piles and Drilled Shafts

Division C (Additional Considerations in Planning, Design and Construction of Building Foundations) deals with the following sections:

- Excavation
- Dewatering
- Slope Stability of Adjoining Building
- Fills
- Retaining Walls for Foundations
- Waterproofing and Damp-proofing
- Foundation on Slopes
- Foundations on Fill and Problematic Soils
- Foundation Design for Dynamic Forces
- Geo-hazards for Buildings

3.2 Scope

The provisions of this Chapter shall be applicable to the design and construction of foundations of buildings and structures for the safe support of dead and superimposed loads without exceeding the allowable bearing stresses, permissible settlements and design capability. Because of uncertainties and randomness involved in sub-soil characteristics, Geotechnical Engineering requires a high degree of engineering judgment. As such the Code provisions of this Chapter provided here under, are kept elaborative for better understanding of the readers. Provisions that are stated in imperative form using “shall” are mandatory. Other provisions of this Chapter should be followed using sound Geotechnical Engineering judgment.

3.3 Definitions and Symbols

3.3.1 Definitions

For the terms used in this Chapter, the following definitions shall apply.

ALLOWABLE BEARING CAPACITY	It is the minimum of the safe bearing capacity and safe settlement pressure, so that the foundation/structure is safe and stable under both shear failure and settlement criteria. It may be denoted by symbol q_{allow} . The lateral dimensions of the foundation (width or diameter and the length) are designed on the basis of allowable bearing capacity. Also known as Allowable Bearing Pressure.
ALLOWABLE LOAD	The maximum load that may be safely applied to a foundation unit, considering both the strength and settlement of the soil, under expected loading and soil conditions.
ANGULAR DISTORTION	Angle between the horizontal and any two foundations or two points in a single foundation.
AUGUR PILE	Same as SCREW PILE.
BATTER PILE	The pile which is installed at an angle to the vertical in order to carry lateral loads along with the vertical loads. This is also known as RAKER PILE.
BEARING CAPACITY	The general term used to describe the load carrying capacity of foundation soil or rock in terms of average pressure that enables it to bear and transmit loads from a structure.

BEARING SURFACE	The contact surface between a foundation unit and the soil or rock upon which the foundation rests.
BORED PILE	A pile formed into a preformed hole of ground, usually of reinforced concrete having a diameter smaller than 600 mm.
BOULDER	Particles of rock that will not pass a 12 inch. (300 mm) square opening.
CAISSON	A deep foundation unit, relatively large section, sunk down (not driven) to the ground. This is also called WELL FOUNDATION.
CAST IN-SITU PILE	Same as BORED PILE.
CLAY	A natural aggregate of microscopic and submicroscopic mineral grains less than 0.002 mm in size and plastic in moderate to wide range of water contents.
CLAY MINERAL	A small group of minerals, commonly known as clay minerals, essentially composed of hydrous aluminium silicates with magnesium or iron replacing wholly or in part some of the aluminium.
CLAY SOIL	Same as CLAY.
COBBLE	Particles of rock that will pass a 12-in. (300-mm) square opening and be retained on a 3-in. (75-mm) sieve.
COLLAPSIBLE SOIL	Consists predominant of sand and silt size particles arranged in a loose honeycomb structure. These soils are dry and strong in their natural state and consolidate or collapse quickly if they become wet.
CONSOLIDATION SETTLEMENT	A time dependent settlement resulting from gradual reduction of volume of saturated soils because of squeezing out of water from the pores due to increase in effective stress and hence pore water pressure. It is also known as primary consolidation settlement. It is thus a time related process involving compression, stress transfer and water drainage.

DEEP FOUNDATION	A foundation unit that provides support for a structure transferring loads by end bearing and/or by shaft resistance at considerable depth below the ground. Generally, the depth is at least five times the least dimension of the foundation.
DESIGN BEARING CAPACITY	The maximum net average pressure applied to a soil or rock by a foundation unit that the foundation soil or rock will safely carry without the risk of both shear failure and exceedance of permissible settlement. It is equal to the least of the two values of net allowable bearing capacity and safe bearing pressure. This may also be called ALLOWABLE BEARING PRESSURE.
DESIGN LOAD	The expected un-factored load to a foundation unit.
DIFFERENTIAL SETTLEMENT	The difference in the total settlements between two foundations or two points in the same foundation.
DISPERSIVE SOIL	Soils that are structurally unstable and disperse in water into basic particles i.e. sand, silt and clay. Dispersible soils tend to be highly erodible. Dispersive soils usually have a high Exchangeable Sodium Percentage (ESP).
DISPLACEMENT PILE	Same as DRIVEN PILE.
DISTORTION SETTLEMENT	Same as ELASTIC SETTLEMENT.
DOWNDRAG	The transfer of load (drag load) to a deep foundation, when soil settles in relation to the foundation. This is also known as NEGATIVE SKIN FRICTION.
DRILLED PIER	A deep foundation generally of large diameter shaft usually more than 600 mm and constructed by drilling and excavating into the soil.
DRILLED SHAFT	Same as DRILLED PIER.
DRIVEN PILE	A pile foundation pre-manufactured and placed in ground by driving, jacking, jetting or screwing.

EFFECTIVE STRESS	The pressure transmitted through grain to grain at the contact point through a soil mass is termed as effective stress or effective pressure.
ELASTIC SETTLEMENT	It is attributed due to lateral spreading or elastic deformation of dry, moist or saturated soil without a change in the water content and volume.
END BEARING	The load being transmitted to the toe of a deep foundation and resisted by the bearing capacity of the soil beneath the toe.
EXCAVATION	The space created by the removal of soil or rock for the purpose of construction.
EXPANSIVE SOIL	These are clay soils expand when they become wetted and contract when dried. These are formed of clay minerals like montmorillonite and illite.
FACTOR OF SAFETY	The ratio of ultimate capacity to design (working) capacity of the foundation unit.
FILL	Man-made deposits of natural earth materials (soil, rock) and/or waste materials.
FOOTING	A foundation constructed of masonry, concrete or other material under the base of a wall or one or more columns for the purpose of spreading the load over a larger area at shallower depth of ground surface.
FOUNDATION	Lower part of the structure which is in direct contact with the soil and transmits loads to the ground.
FOUNDATION ENGINEER	A graduate Engineer with at least five years of experience in civil engineering particularly in foundation design or construction.
GEOTECHNICAL ENGINEER	Engineer with Master's degree in geotechnical engineering having at least 2 (two) years of experience in geotechnical design/construction or graduate in civil engineering/engineering geology having 10 (ten) years of experience in geotechnical design/construction.

GRAVEL	Particles of rock that will pass a 3-in. (75-mm) sieve and be retained on a No. 4 (4.75-mm) sieve.
GROSS PRESSURE	The total pressure at the base of a footing due to the weight of the superstructure and the original overburden pressure.
GROSS ALLOWABLE BEARING PRESSURE	The maximum gross average pressure of loading that the soil can safely carry with a factor of safety considering risk of shear failure. This may be calculated by dividing gross ultimate bearing capacity with a factor of safety.
GROUND WATER TABLE	The level of water at which porewater pressure is equal to atmospheric pressure. It is the top surface of a free body of water (piezometric water level) in the ground.
IMMEDIATE SETTLEMENT	This vertical compression occurs immediately after the application of loading either on account of elastic behaviour that produces distortion at constant volume and on account of compression of air void. For sands, even the consolidation component is immediate.
INORGANIC SOIL	Soil of mineral origin having small amount usually less than 5 percent of organic matter content.
LATERALLY LOADED PILE	A pile that is installed vertically to carry mainly the lateral loads.
MAT FOUNDATION	See RAFT.
NEGATIVE SKIN FRICTION	See DOWNDRAG.
NET PRESSURE	The gross pressure minus the surcharge pressure i.e. the overburden pressure of the soil at the foundation level.
NET SAFE BEARING CAPACITY	The maximum net pressure that can be safely applied from the foundation on the soil at its base, and at which the shear failure of the soil is avoided with a suitable factor of safety (FS). It is denoted by symbol q_{ns} . Thus, $q_{ns} = \frac{q_{nu}}{FS}$.

NET ULTIMATE BEARING CAPACITY	The minimum net pressure at the base of the foundation, excluding the weight of the overburden, at which the soil fails in shear due to the load on the foundation from superstructure. It is denoted by the symbol q_{nu} . Thus, $q_{nu} = q_{ult} - q'$ where, q' is the effective stress at foundation level due to overburden soil.
ORGANIC SOIL	Soil having appreciable/significant amount of organic matter content to influence the soil properties.
OVERCONSOLIDATION RATIO (OCR)	The ratio of the preconsolidation pressure (maximum past pressure) to the existing effective overburden pressure of the soil.
PEAT SOIL	An organic soil with high organic content, usually more than 75% by weight, composed primarily of vegetable tissue in various stages of decomposition usually with an organic odor, a dark brown to black color, a spongy consistency, and a texture ranging from fibrous to amorphous. Fully decomposed organic soils are known as MUCK.
PILE	A slender deep foundation unit made of materials such as steel, concrete, wood, or combination thereof that transmits the load to the ground by skin friction, end bearing and lateral soil resistance.
PILE CAP	A pile cap is a special footing needed to transmit the column load to a group or cluster of piles.
PILE HEAD	The upper small length of a pile. Also known as pile top.
PILE SHOE	A separate reinforcement or steel form attached to the bottom end (pile toe) of a pile to facilitate driving, to protect the pile toe, and/or to improve the toe resistance of the pile.
PILE TOE	The bottom end of a pile. Also known as pile tip.
PORE WATER PRESSURE	The pressure induced in the water or vapour and water filling the pores of soil. This is also known as neutral stress.

PRESUMPTIVE BEARING CAPACITY	The net approximate pressure prescribed as appropriate for the particular type of ground to be used in preliminary designs of foundations
RAFT	A relatively large spread foundation supporting an arrangement of columns or walls in a regular or irregular layout transmitting the loads to the soil by means of a continuous slab and/or beams, with or without depressions or openings. This is also known as MAT FOUNDATION.
RAKER PILE	See BATTER PILE.
ROCK	A natural aggregate of one or more minerals that are connected by strong and permanent cohesive forces.
ROTATION	It is the angle between the horizontal and any two foundations or two points in a single foundation.
RELATIVE ROTATION	Same as ANGULAR DISTORTION
REPLACEMENT PILE	Same as BORED PILE.
SAFE BEARING CAPACITY	It is the maximum gross pressure that can carry safely, without shear failure. It is denoted by symbol q_{safe} . Thus, $q_{safe} = q_{ns} + q'$. When the excavation for foundation is backfilled, $q_{safe} = q_{ns}$.
SAFE SETTLEMENT PRESSURE	The maximum pressure that can be applied from the foundation on the soil at its base such that the settlement of the foundation/structure is less than or equal to the permissible settlement. It may be denoted by symbol q_{sp} .
SAND	Aggregates of rounded, sub-rounded, angular, sub-angular or flat fragments of more or less unaltered rock or minerals which is larger than 75 μm and smaller than 4.75 mm in size.
SCREW PILE	A pre-manufactured pile consisting of steel helical blades and a shaft placed into ground by screwing.
SECONDARY CONSOLIDATION SETTLEMENT	This is the settlement speculated to be due to the plastic deformation of the soil as a result of some complex colloidal-chemical processes or creep under imposed long term loading.

SERVICE LOAD	The expected un-factored load to a foundation unit.
SETTLEMENT	The downward vertical movement of foundation under load. When settlement occurs over a large area, it is sometimes called subsidence.
SHAFT RESISTANCE	The resistance mobilized on the shaft (side) of a deep foundation. Upward resistance is called positive shaft resistance. Downward force on the shaft is called negative shaft resistance.
SHALLOW FOUNDATION	A foundation unit that provides support for a structure transferring loads at a small depth below the ground. Generally, the depth is less than two times the least dimension of the foundation.
SILT	Soil passing a No. 200 (75- μ m) sieve either non-plastic or plastic.
SOIL	A loose or soft deposit of particles of mineral and/or organic origin that can be separated by such gentle mechanical means as agitation in water.
SOIL PARTICLE SIZE	The sizes of particles that make up soil varying over a wide range. Soil particles are generally gravel, sand, silt and clay, though the terms boulder and cobble can be used to describe larger sizes of gravel.
TILT	Rotation of the entire superstructure or at least a well-defined part of it.
TOTAL SETTLEMENT	The total downward vertical displacement of a foundation base under load from its as-constructed position. It is the summation of immediate settlement, consolidation settlement and secondary consolidation settlement of the soil.
ULTIMATE BEARING CAPACITY	The minimum gross pressure at the base of the foundation at which the soil fails in shear due to the load on the foundation from superstructure. It is denoted by the symbol q_{ult} and obtained from bearing capacity equation containing soil/ground properties, depth of foundation, foundation dimensions and shapes, and loading conditions. Also known as Gross Ultimate Bearing Capacity.

3.3.2 Symbols and Notation

Every symbol used in this Chapter is explained where it first appears in the text. However, for convenience of the reader, a list of main symbols and notation is provided as under. Other common symbols and notation like those of soil classifications are not included in this list.

A	= Cross sectional area of pile
A_b	= End bearing area of pile
A_s	= Skin friction area (perimeter area) of pile
B	= Width of footing/foundation (Sec 3.9.6, Sec 3.20.2)
B	= Smallest dimension of pile group (Sec 3.10.5)
B_p	= Width of plate
B_r	= Reference width (300 mm) for computation of pile settlement
CEC	= Cation exchange capacity
CRR	= Cyclic resistance ratio
CSR	= Cyclic stress ratio
C_c	= Compression index of soil
C_p	= Empirical coefficient used for pile settlement computation
C_u	= Uniformity coefficient
C_z	= Coefficient of curvature
D	= Diameter or width of pile
D_b	= Diameter of pile at base
D_c	= Critical depth of soil layer
D_{10}	= Effective grain size; the size of soil particle from which 10 percent of the soil is finer
D_{30}	= The size of soil particle from which 30 percent of the soil is finer
D_{60}	= The size of soil particle from which 60 percent of the soil is finer
EI	= Flexural rigidity of footing
Em_aP	= Exchangeable magnesium percentage
E_p	= Modulus of elasticity of pile material
E_s	= Modulus of elasticity of soil
ESP	= Exchangeable sodium percentage

F_L	=	Factor of safety against liquefaction
FS	=	Factor of safety
G	=	Modulus of rigidity
H	=	Height of wall from foundation footing (Sec 3.9.4)
H	=	Layer thickness (Sec 3.10.5)
H	=	Thickness of sample (Sec 3.5.6)
H'	=	Final thickness of sample (Sec 3.5.6)
I_p	=	Plasticity index
I_{subs}	=	Relative subsidence
K	=	Coefficient of earth pressure
K_o	=	Coefficient of earth pressure at rest
L	=	Length of pile (Sec 3.10)
L	=	Length of deflected part of wall/raft or centre to centre distance between columns. (Sec 3.9.4)
LL		Liquid limit
N	=	Standard penetration test value (SPT)
N_{60}	=	Corrected SPT value for field procedures
\bar{N}_{60}	=	Average SPT N_{60} value
$(N_1)_{60}$	=	Corrected SPT value for overburden pressure (for sandy soil)
N_c, N_q, N_γ	=	Bearing capacity factors
OCR	=	Overconsolidation ratio
PI	=	Plasticity index; same as I_p
Q_{allow}	=	Allowable load
Q_p	=	End bearing at the base or tip of the pile
Q_p	=	Load transferred to the soil at pile tip level
Q_s	=	Skin friction or shaft friction or side shear
Q_{ult}	=	Ultimate bearing/load carrying capacity
R_s	=	Group settlement ratio of pile group
S_{ax}	=	Settlement due to axial deformation
S_g	=	Settlement of pile group
S_{pt}	=	Settlement at pile tip

S_{sf}	= Settlement of pile due to skin friction
S_r	= Degree of saturation
$S_{t(sinate)}$	= Total settlement of a single pile
W	= Weight of the pile
WPI	= Weighted plasticity index
a_{max}	= Peak horizontal acceleration on the ground surface
c	= Apparent cohesion of soil
c_u	= Undrained cohesion of soil
d_p	= Diameter of pile
e	= Void ratio
e_c	= Critical void ratio
e_L	= Void ratio at liquid limit
e_P	= Void ratio at plastic limit
e_i	= Initial void ratio
e_o	= Initial void ratio; same as e_i
f_b	= End bearing resistance on unit tip area of pile
f_n	= Natural frequency
f_s	= Skin frictional resistance on unit surface area of pile
f_s	= Adhesive stress (Sec. 3.10.1.12)
g	= Gravitational acceleration
k	= Modulus of sub-grade reaction
k_p	= Stiffness of soil
k_s	= Coefficient of horizontal soil stress
m	= Total mass of machine foundation system
m_f	= Mass of foundation block
m_s	= Mass of soil
n	= Number of pile in a group
q_{allow}	= Allowable bearing capacity of shallow foundation
q_o	= Ultimate end bearing capacity pile
q_{ns}	= Net safe ultimate bearing capacity of shallow foundation
q_{nu}	= Net ultimate bearing capacity of shallow foundation

q_{safe}	= Safe ultimate bearing capacity
q_{sp}	= Safe settlement pressure of shallow foundation
q_u	= Unconfined compressive strength
q_{ult}	= Ultimate bearing capacity of shallow foundation
r_d	= Stress reduction coefficient to allow for the deformability of the soil column
s_u	= undrained shear strength; same as c_u
w_L	= Liquid limit; same as LL
z	= Depth
Δz_i	= Thickness of any (i^{th}) layer
α	= Adhesion factor
β	= Ratio of footing length to width (Sec 3.9.6.8)
β	= Friction factor due to overburden (3.10.1)
γ, γ_t	= Unit weight of the soil
γ_w	= Unit weight of water
δ	= Total settlement
δ_c	= Consolidation settlement
δ_e	= Elastic settlement
δ_i	= Immediate settlement
δ_s	= Secondary consolidation settlement
μ	= Poisson's ratio of soil
σ'_o	= Initial effective stress at mid-point of a soil layer
σ'_p	= Increase in effective stress at mid-point of a soil layer due to increase in stress
σ'_r	= Reference stress (100 kPa) for computation of pile settlement
σ_v	= The total vertical stress
σ'_v	= Effective vertical stress
σ'_z	= Effective vertical stress; same as σ'_v
τ_{max}	= Maximum shear stress
ϕ	= Apparent angle of internal friction
ϕ'	= Effective/drained angle of internal friction
ϕ_s	= Soil shaft interface friction angle
ω_n	= natural circular frequency

Division A: Site Investigations, Soil Classifications, Materials and Foundation Types (Sections 3.4 to 3.7)

3.4 Site Investigations

3.4.1 Sub-Surface Survey

Depending on the type of project thorough investigations has to be carried out for identification, location, alignment and depth of various utilities, e.g., pipelines, cables, sewerage lines, water mains etc. below the surface of existing ground level. Detailed survey may also be conducted to ascertain the topography of existing ground.

3.4.2 Sub-Soil Investigations

Sub soil investigation shall be done describing the character, nature, load bearing capacity and settlement capacity of the soil before constructing a new building and structure or for alteration of the foundation of an existing structure. The aims of a geotechnical investigation are to establish the soil, rock and groundwater conditions, to determine the properties of the soil and rock, and to gather additional relevant knowledge about the site. Careful collection, recording and interpretation of geotechnical information shall be made. This information shall include ground conditions, geology, geomorphology, seismicity and hydrology, as relevant. Indications of the variability of the ground shall be taken into account.

An engineering geological study may be an important consideration to establish the physiographic setting and stratigraphic sequences of soil strata of the area. Geological and agricultural soil maps of the area may give valuable information of site conditions.

During the various phases of sub-soil investigations, e.g. drilling of boreholes, field tests, sampling, groundwater measurements, etc. a competent graduate engineer having experiences in supervising sub-soil exploration works shall be employed by the drilling contractor.

3.4.3 Methods of Exploration

Sub soil exploration process may be grouped into three types of activities such as: reconnaissance, exploration and detailed investigations. The reconnaissance method includes geophysical measurements, sounding or probing, while exploratory methods involve various drilling techniques. Field investigations should comprise :

- (i) Drilling and/or excavations (test pits including exploratory boreholes) for sampling;
- (ii) Groundwater measurements;
- (iii) Field tests.

Examples of the various types of field investigations are:

- (i) Field testing (e.g. CPT, SPT, dynamic probing, WST, pressuremeter tests, dilatometer tests, plate load tests, field vane tests and permeability tests);
- (ii) Soil sampling for description of the soil and laboratory tests;
- (iii) Groundwater measurements to determine the groundwater table or the pore pressure profile and their fluctuations
- (iv) Geophysical investigations (e.g. seismic profiling, ground penetrating radar, resistivity measurements and down hole logging);
- (v) Large scale tests, for example to determine the bearing capacity or the behaviour directly on prototype elements, such as anchors.

Where ground contamination or soil gas is expected, information shall be gathered from the relevant sources. This information shall be taken into account when planning the ground investigation. Some of the common methods of exploration, sampling and ground water measurements in soils are described in Appendix D.

3.4.4 Number and Location of Investigation Points

The locations of investigation points, e.g., pits and boreholes shall be selected on the basis of the preliminary investigations as a function of the geological conditions, the dimensions of the structure and the engineering problems involved. When selecting the locations of investigation points, the following should be observed:

- (i) The investigation points should be arranged in such a pattern that the stratification can be assessed across the site;
- (ii) The investigation points for a building or structure should be placed at critical points relative to the shape, structural behaviour and expected load distribution (e.g. at the corners of the foundation area);
- (iii) For linear structures, investigation points should be arranged at adequate offsets to the centre line, depending on the overall width of the structure, such as an embankment footprint or a cutting;
- (iv) For structures on or near slopes and steps in the terrain (including excavations), investigation points should also be arranged outside the project area, these being located so that the stability of the slope or cut can be assessed. Where anchorages are installed, due consideration should be given to the likely stresses in their load transfer zone;

- (v) The investigation points should be arranged so that they do not present a hazard to the structure, the construction work, or the surroundings (e.g. as a result of the changes they may cause to the ground and groundwater conditions);
- (vi) The area considered in the design investigations should extend into the neighbouring area to a distance where no harmful influence on the neighbouring area is expected. Where ground conditions are relatively uniform or the ground is known to have sufficient strength and stiffness properties, wider spacing or fewer investigation points may be applied. In either case, this choice should be justified by local experience.
- (vii) The locations and spacing of sounding, pits and boreholes shall be such that the soil profiles obtained will permit a reasonably accurate estimate of the extent and character of the intervening soil or rock masses and will disclose important irregularities in subsurface conditions.
- (viii) For building structures, the following guidelines shall be followed:

On uniform soils, at least three borings, not in one line, should be made for small buildings and at least five borings one at each corner and one at the middle should be made for large buildings. As far as possible the boreholes should be drilled closed to the proposed foundations but outside their outlines.

Spacing of exploration depends upon nature and condition of soil, nature and size of the project. In uniform soil, spacing of exploration (boring) may be 30 m to 100 m apart or more and in very erratic soil conditions, spacing of 10 m or less may be required. The following chart gives an approximate idea about spacing of boring required for small and multistoried buildings having different horizontal stratification of soil.

Type of Building	Spacing of Bore Holes (m)		
	Type of Soil in Horizontal Stratification		
	Uniform	Average	Erratic
Small buildings	60	30	15
Multistoried buildings	45	30	15

- (ix) For large areas covering industrial and residential colonies, the geological nature of the terrain will help in deciding the number of boreholes or trial pits. The whole area may be divided into grid pattern with Cone Penetration Tests (Appendix D) performed at every 100 m grid points. The number of boreholes or trial pits shall be decided by examining the variation in penetration curves. At least 67% of the required number of borings or trial pits shall be located within the area under the building.

3.4.5 Depth of Exploration

The depth of investigations shall be extended to all strata that will affect the project or are affected by the construction. The depth of exploration shall depend to some extent on the site and type of the proposed structure, and on certain design considerations such as safety against foundation failure, excessive settlement, seepage and earth pressure. Cognizance shall be taken of the character and sequence of the subsurface strata. The site investigation should be carried to such a depth that the entire zone of soil or rock affected by the changes caused by the building or the construction will be adequately explored. A rule of thumb used for this purpose is to extend the borings to a depth where the additional load resulting from the proposed building is less than 10% of the average load of the structure, or less than 5% of the effective stress in the soil at that depth. Where the depth of investigation cannot be related to background information, the following guide lines are suggested to determine the depth of exploration:

- (i) Where substructure units will be supported on spread footings, the minimum depth boring should extend below the anticipated bearing level a minimum of two footing widths for isolated, individual footings where length ≤ 2 times of width, and four footing widths for footings where length > 5 times of width. For intermediate footing lengths, the minimum depth of boring may be estimated by linear interpolation as a function of length between depths of two times width and five times width below the bearing level. Greater depth may be required where warranted by local conditions.
- (ii) For more heavily loaded structures, such as multistoried structures and for framed structures, at least 50% of the borings should be extended to a depth equal to 1.5 times the width of the building below the lowest part of the foundation.

- (iii) Normally the depth of exploration shall be 1.5 times the estimated width or the least dimension of the footing below the foundation level. If the pressure bulbs for a number of loaded areas overlap, the whole area may be considered as loaded and exploration shall be carried down to one and a half times the least dimension. In weak soils, the exploration shall be continued to a depth at which the loads can be carried by the stratum in question without undesirable settlement or shear failure.
- (iv) Where substructure units will be supported on deep foundations, the depth boring should extend a minimum of 6 m below the anticipated pile or shaft tip elevation. Where pile or shaft groups will be used, the boring should extend at least two times the maximum pile or shaft group dimension below the anticipated tip elevation, unless the foundation will be end bearing on or in rock.
- (v) For piles bearing on rock, a minimum of 1.5 m of rock core should be obtained at each boring location to ensure the boring has not been terminated in a boulder.
- (vi) For shafts supported on or extending into rock, a minimum of 1.5 m of rock core, or a length of rock core equal to at least three times the shaft diameter for isolated shafts or two times the maximum shaft group dimension for a shaft group, whichever is greater, should be obtained to ensure that the boring had not been terminated in a boulder and to determine the physical properties of rock within the zone of foundation influence for design.
- (vii) The depth, to which weathering process affects the deposit, shall be regarded as the minimum depth of exploration for a site. However, in no case shall this depth be less than 2 m, but where industrial processes affect the soil characteristics, this depth may be more.
- (viii) At least one boring should be carried out to bedrock, or to well below the anticipated level of influence of the building. Bedrock should be ascertained by coring into it to a minimum depth of 3 m.

3.4.6 Sounding and Penetration Tests

Subsurface soundings are used for exploring soil strata of an erratic nature. They are useful to determine the presence of any soft pockets between drill holes and also to determine the density index of cohesionless soils and the consistency of cohesive soils at desired depths. A field test called Vane Shear Test may be used to determine the shearing strength of the soil located at a depth below the ground.

Penetration tests consist of driving or pushing a standard sampling tube or a cone. The devices are also termed as penetrometers, since they penetrate the subsoil with a view to measuring the resistance to penetrate the soil strata. If a sampling tube is used to penetrate the soil, the test is referred to as Standard Penetration Test (or simply SPT). If a cone is used, the test is called a Cone Penetration Test. If the penetrometer is pushed steadily into the soil, the procedure is known as Static Penetration Test. If driven into the soil, it is known as Dynamic Penetration Test. Details of sounding and penetrations tests are presented in Appendix D.

3.4.7 Geotechnical Investigation Report

The results of a geotechnical investigation shall be compiled in the Geotechnical Investigation Report which shall form a part of the Geotechnical Design Report. The Geotechnical Investigation Report shall consist of the following :

- (i) A presentation of all appropriate geotechnical information on field and laboratory tests including geological features and relevant data;
- (ii) A geotechnical evaluation of the information, stating the assumptions made in the interpretation of the test results.

The Geotechnical Investigation Report shall state known limitations of the results, if appropriate. The Geotechnical Investigation Report should propose necessary further field and laboratory investigations, with comments justifying the need for this further work. Such proposals should be accompanied by a detailed programme for the further investigations to be carried out. The presentation of geotechnical information shall include a factual account of all field and laboratory investigations. The factual account should include the following information :

- (i) The purpose and scope of the geotechnical investigation including a description of the site and its topography, of the planned structure and the stage of the planning the account is referring to;
- (ii) The names of all consultants and contractors;
- (iii) The dates between which field and laboratory investigations were performed;
- (iv) The field reconnaissance of the site of the project and the surrounding area noting particularly :
 - evidence of groundwater;
 - behaviour of neighbouring structures;
 - exposures in quarries and borrow areas;

- areas of instability;
- difficulties during excavation;
- history of the site;
- geology of the site,
- survey data with plans showing the structure and the location of all investigation points;
- local experience in the area;
- information on the seismicity of the area.

The presentation of geotechnical information shall also include documentation of the methods, procedures and results including all relevant reports of :

- (i) desk studies;
- (ii) field investigations, such as sampling, field tests, groundwater measurements and technical specifications of field equipment used
- (iii) laboratory tests and test standard followed

The results of the field and laboratory investigations shall be presented and reported according to the requirements defined in the ASTM or equivalent standards applied in the investigations.

3.5 Identification, Classification and Description of Soils

3.5.1 Identification of Soils

Samples and trial pits should be inspected visually and compared with field logs of the drillings so that the preliminary ground profile can be established. For soil samples, the visual inspection should be supported by simple manual tests to identify the soil and to give a first impression of its consistency and mechanical behaviour. A standard visual-manual procedure of describing and identifying soils may be followed.

Soil classification tests should be performed to determine the composition and index properties of each stratum. The samples for the classification tests should be selected in such a way that the tests are approximately equally distributed over the complete area and the full depth of the strata relevant for design.

3.5.2 Particle Size Classification of Soils

Depending on particle sizes, main soil types are gravel, sand, silt and clay. However, the larger gravels can be further classified as cobble and boulder. The soil particle size shall be classified in accordance with Table 6.3.1.

Table 6.3.1: Particle Size Ranges of Soils

Soil Type	Particle Size Range (mm)	Retained on Mesh Size/ Sieve No.
Boulder	> 300	12"
Cobble	300 – 75	3"
Gravel:		
Coarse Gravel	75 – 19	3/4"
Medium Gravel	19 – 9.5	3/8"
Fine Gravel	9.5 – 4.75	No. 4
Sand:		
Coarse Sand	4.75 – 2.00	No. 10
Medium Sand	2.00 – 0.425	No. 40
Fine Sand	0.425 – 0.075	No. 200
Silt	0.075 – 0.002	---
Clay	< 0.002	---

3.5.3 Engineering Classification of Soils

Soils are divided into three major groups, coarse grained, fine grained and organic. The classification is based on classification test results namely grain size analysis and consistency test. The coarse grained soils shall be classified using Table 6.3.2. Outlines of organic and inorganic soil separations are also provided in Table 6.3.2. The fine grained soils shall be classified using the plasticity chart shown in Figure 6.3.1. In this context, this Code adopts the provisions of ASTM D2487. In addition to these classifications, a soil shall be described by its colour, particle angularity (for coarse grained soils) and consistency. Further to the above classification soils exhibiting swelling or collapsing characteristic shall be recorded. For undisturbed soils information on stratification, compactness, cementation, moisture conditions and drainage characteristics shall be included.

Table 6.3.2: Engineering Classification of Soils (Criteria for Assigning Group Symbols and Names using Laboratory Tests ^A)

Classification (For particles smaller than 75 mm and based on estimated weights)			Group Symbol	Group Name ^B	Laboratory Classification			
					Percent finer than 0.075 mm	Other Criteria		
Coarse grained soils (More than 50% of the material retained on No. 200 sieve (0.075 mm))	Gravels (More than 50% of coarse fraction retained on No. 4 sieve (4.75 mm))	Clean gravels	GW	Well graded gravels, sandy gravels, sand gravel mixture, little or no fines. ^D	< 5 ^E	C _u ≥ 4 and 1 ≤ C _z ≤ 3 ^C		
			GP	Poorly graded gravels, sandy gravels, Sand gravel mixture, little or no fines. ^D		C _u < 4 and/or 1 > C _z > 3 ^C		
		Gravel with fines	GM	Silty gravels, silty sandy gravels. ^{D, F, G}	> 12 ^E	Ip < 4 or the limit values below 'A' line of plasticity chart	For 4 > Ip > 7 and limit values above 'A' line, dual symbol required*	
			GC	Clayey gravels, silty clayey gravels. ^{D, F, G}		Ip > 7 and the limit values above 'A' line of Plasticity Chart		
	Sands (over 50% of coarse fraction smaller than 4.75 mm)	Clean Sands	SW	Well graded sand, gravelly sand, little or no fines. ^H	< 5 ^E	C _u ≥ 6 and 1 ≤ C _z ≤ 3 ^C		
			SP	Poorly graded sands, gravelly sand, little or no fines. ^H		C _u < 6 and/or 1 > C _z > 3 ^C		
		Sands with fines	SM	Silty sand, poorly graded sand silt mixtures. ^{F, G, H}	> 12 ^E	Ip < 4 or the limit values below 'A' line of Plasticity chart	For 4 > Ip > 7 and limit values above A-line, dual symbols required.	
			SC	Clayey sand, sand clay mixtures. ^{F, G, H}		Ip > 7 and the limit values above 'A' line of plasticity chart		
	Fine grained soils (Over 50% of the material smaller than 0.075 mm)	Silts & Clays w _L < 50	Inorganic	ML	Silt of low to medium compressibility, very fine sands, rock flour, silt with sand. ^{K, L, M}	Limit values on or below 'A' line of plasticity chart & Ip < 4		
				CL	Clays of low to medium plasticity, gravelly clay, sandy clay, silty clay, lean clay. ^{K, L, M}	Limit values above 'A' line of plasticity chart and/or Ip > 4		
Organic			OL	Organic clay ^{K, L, M, N} and Organic silt ^{K, L, M, O} of low to medium plasticity	$\frac{\text{Liquid limit (oven dried)}}{\text{Liquid limit (undried)}} < 0.75$			

Classification (For particles smaller than 75 mm and based on estimated weights)			Group Symbol	Group Name ^B	Laboratory Classification	
					Percent finer than 0.075 mm	Other Criteria
Fine grained soils (Over 50% of the material smaller than 0.075 mm)	Silts & Clays $w_L \geq 50$	Inorganic	MH	Silt of high plasticity, micaceous fine sandy or silty soil, elastic silt. ^{K, L, M}	Limit values on or below 'A' line of plasticity chart	
			CH	High plastic clay, fat clay. ^{K, L, M}	Limit values above 'A' line of plasticity chart	
		Organic	OH	Organic clay of high plasticity. ^{K, L, M, P}	$\frac{\text{Liquid limit (oven dried)}}{\text{Liquid limit (undried)}} < 0.75$	
Soils of high organic origin			PT	Peat and highly organic soils. ^{K, L, M, Q}	Identified by colour, odour, fibrous texture and spongy characteristics.	
Notes:						
<p>^A Based on the material passing the 3-in. (75-mm) sieve</p> <p>^B If field sample contained cobbles or boulders, or both, add "with cobbles or boulders, or both" to group name.</p> <p>^C $C_u = D_{60}/D_{10}$, $C_z = (D_{30})^2 / (D_{10} \times D_{60})$</p> <p>^D If soil contains $\geq 15\%$ sand, add "with sand" to group name.</p> <p>^E Gravels with 5 to 12 % fines require dual symbols:</p> <p style="padding-left: 40px;">GW-GM well-graded gravel with silt</p> <p style="padding-left: 40px;">GW-GC well-graded gravel with clay</p> <p style="padding-left: 40px;">GP-GM poorly graded gravel with silt</p> <p style="padding-left: 40px;">GP-GC poorly graded gravel with clay</p> <p>^F If fines classify as CL-ML, use dual symbol GC-GM, or SC-SM.</p> <p>^G If fines are organic, add "with organic fines" to group name.</p> <p>^H If soil contains $\geq 15\%$ gravel, add "with gravel" to group name.</p> <p>^I Sands with 5 to 12 % fines require dual symbols:</p> <p style="padding-left: 40px;">SW-SM well-graded sand with silt</p> <p style="padding-left: 40px;">SW-SC well-graded sand with clay</p> <p style="padding-left: 40px;">SP-SM poorly graded sand with silt</p> <p style="padding-left: 40px;">SP-SC poorly graded sand with clay.</p> <p>^J If Atterberg limits plot in hatched area, soil is a CL-ML, silty clay.</p> <p>^K If soil contains 15 to 29 % plus No. 200, add "with sand" or "with gravel," whichever is predominant.</p> <p>^L If soil contains $\geq 30\%$ plus No. 200, predominantly sand, add "sand" to group name.</p> <p>^M If soil contains $\geq 30\%$ plus No. 200, predominantly gravel, add "gravelly" to group name.</p> <p>^N $PI \geq 4$ and plots on or above "A" line.</p> <p>^O $PI < 4$ or plots below "A" line.</p> <p>^P PI plots on or above "A" line.</p> <p>^Q PI plots below "A" line.</p>						

If desired, the percentages of gravel, sand, and fines may be stated in terms indicating a range of percentages, as follows:

- Trace – Particles are present but estimated to be less than 5 %
- Few – 5 to 10 %
- Little – 15 to 25 %
- Some – 30 to 45 %
- Mostly – 50 to 100 %

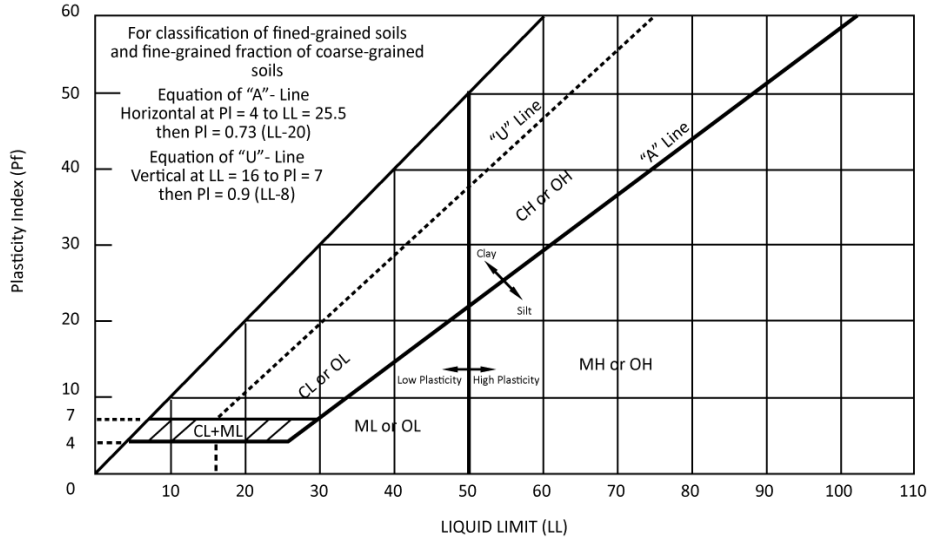


Figure 6.3.1 Plasticity chart (based on materials passing 425 µm sieve)

3.5.4 Identification and Classification of Organic Soils

The presence of organic matter can have undesirable effects on the engineering behaviour of soil. For example, the bearing capacity is reduced, the compressibility is increased and, swelling and shrinkage potential is increased due to organic content. Organic content tests are used to classify the soil. In soil with little or no clay particles and carbonate content, the organic content is often determined from the loss on ignition at a controlled temperature. Other suitable tests can also be used. For example, organic content can be determined from the mass loss on treatment with hydrogen peroxide (H_2O_2), which provides a more specific measure of organics. Organic deposits are due to decomposition of organic matters and found usually in topsoil and marshy place. A soil deposit in organic origin is said to peat if it is at the higher end of the organic content scale (75% or more), organic soil at the low end, and muck in between. Peat soil is usually formed of fossilized plant minerals and characterized by fiber content and lower decomposition. The peats have certain

characteristics that set them apart from moist mineral soils and required special considerations for construction over them. This special characteristic includes, extremely high natural moisture content, high compressibility including significant secondary and even tertiary compression and very low undrained shear strength at natural moisture content.

However, there are many other criteria existed to classify the organic deposits and it remains still as controversial issue with numerous approaches available for varying purpose of classification. A possible approach is being considered by the American society for Testing and Materials for classifying organic soils having varying amount of organic matter contents. The classification is given in Table 6.3.3.

Table 6.3.3: Classification and Description of Organic Soils (after Edil, 1997)

Organic Content (ASTM D2974-07a)	Description
< 5 %	Little effect on behavior; considered inorganic soil.
6 ~ 20 %	Effects properties but behavior is still like mineral soils; organic silts and clays.
21 ~ 74 %	Organic matter governs properties; traditional soil mechanics may be applicable; silty or clayey organic soils.
> 75 %	Displays behavior distinct from traditional soil mechanics especially at low stress.

3.5.5 Identification and Classification of Expansive Soils

Expansive soils are those which swell considerably on absorption of water and shrink on the removal of water. In monsoon seasons, expansive soils imbibe water, become soft and swell. In drier seasons, these soils shrink or reduce in volume due to evaporation of water and become harder. As such, the seasonal moisture variation in such soil deposits around and beneath the structure results into subsequent upward and downward movements of structures leading to structural damage, in the form of wide cracks in the wall and distortion of floors. For identification and classification of expansive soils parameters like liquid limit, plasticity index, shrinkage limit, free swell, free swell index, linear shrinkage, swelling potential, swelling pressure and volume change from air dry to saturate condition should be evaluated experimentally or from available geotechnical correlation. Various recommended criteria for identification and classification of expansive soils are presented in Appendix E.

3.5.6 Identification and Classification of Collapsible Soils

Soil deposits most likely to collapse are; (i) loose fills, (ii) altered wind-blown sands, (iii) hill wash of loose consistency and (iv) decomposed granite or other acid igneous rocks.

A very simple test for recognizing collapsible soil is the "sauges test". Two undisturbed cylindrical samples (sausages) of the same diameter and length (volume) are carved from the soil. One sample is then wetted and kneaded to form a cylinder of the original diameter. A decrease in length as compared to the original, undisturbed cylinder will confirm a collapsible grain structure. Collapse is probable when the natural void ratio, collapsible grain structure. Collapse is probable when the natural void ratio, e_i is higher than a critical void ratio, e_c that depends on void ratios e_L and e_p at liquid limit and plastic limits respectively. The following formula should be used to estimate the critical void ratio.

$$e_c = 0.85 e_L + 0.15 e_p \quad (6.3.1)$$

Collapsible soils (with a degree of saturation, $S_r \leq 0.6$) should satisfy the following condition:

$$\frac{e_L - e_i}{1 + e_i} \leq 0.10 \quad (6.3.2)$$

A consolidation test is to be performed on an undisturbed specimen at natural moisture content and to record the thickness, "H" on consolidation under a pressure "p" equal to overburden pressure plus the external pressure likely to be exerted on the soil. The specimen is then submerged under the same pressure and the final thickness H' recorded. Relative subsidence, I_{subs} is found as:

$$I_{subs} = \frac{H - H'}{H} \quad (6.3.3)$$

Soils having $I_{subs} \geq 0.02$ are considered to be collapsible.

3.5.7 Identification and Classification of Dispersive Soils

Dispersive nature of a soil is a measure of erosion. Dispersive soil is due to the dispersed structure of a soil matrix. An identification of dispersive soils can be made on the basis of pinhole test.

The pinhole test was developed to directly measure dispersive potential of compacted fine grained soils in which water is made to flow through a small hole in a soil specimen, where water flow through the pinhole simulates water flow through a crack or other concentrated leakage channel in the impervious core of a dam or other structure. The test is run under 50, 180, 380 and 1020 mm heads and the soil is classified as follows in Table 6.3.4.

Table 6.3.4: Classification of Dispersive Soil on the Basis of Pinhole Test (Sherard et. al. 1976)

Test Observation	Type of Soil	Class of Soil
Fails rapidly under 50 mm head.	Dispersive soils	D ₁ and D ₂
Erode slowly under 50 mm or 180 mm head	Intermediate soils	ND ₄ and ND ₃
No colloidal erosion under 380 mm or 1020 mm head	Non-dispersive soils	ND ₂ and ND ₁

Another method of identification is to first determine the pH of a 1:2.5 soil/water suspension. If the pH is above 7.8, the soil may contain enough sodium to disperse the mass. Then determine: (i) total exchangeable bases, that is, K^+ , Ca^{2+} , Mg^{2+} and Na_+ (milliequivalent per 100g of air dried soil) and (ii) cation exchange capacity (CEC) of soil (milliequivalent per 100g of air dried soil). The Exchangeable Sodium Percentage ESP is calculated from the relation:

$$ESP = \frac{N_a}{CEC} \times 100(\%) \quad (6.3.4)$$

EM_gP is given by:

$$EM_gP = \frac{Mg}{CEC} \times 100(\%) \quad (6.3.5)$$

If the ESP is above 8 percent and ESP plus EM_gP is above 15, dispersion will take place. The soils with $ESP = 7$ to 10 are moderately dispersive in combination with reservoir waters of low dissolved salts. Soils with ESP greater than 15 have serious piping potential. Dispersive soils do not actually present any problems with building structures. However, dispersive soil can lead to catastrophic failures of earth embankment dams as well as severe distress of road embankments.

3.5.8 Identification and Classification of Soft Inorganic Soils

No standard definition exists for soft clays in terms of conventional soil parameters, mineralogy or geological origin. It is, however, commonly understood that soft clays give shear strength, compressibility and severe time related settlement problems. In near surface clays, where form a crust, partial saturation and overconsolidation occur together and the overconsolidation is a result of the drying out of the clay due to changes in water table.

In below surface clays, overconsolidation may have taken place when the clay was previously at, or close to the ground surface and above the water table, but due to subsequent deposition the strata may now be below the surface, saturated and overconsolidated. Partial saturation does not in itself cause engineering problems, but may lead to laboratory testing difficulties. Soft clays have undrained shear strengths between about 10kPa and 40kPa, in other words, from exuding between the fingers when squeezed to being easily moulded in the fingers.

Soft clays present very special problems of engineering design and construction. Foundation failures in soft clays are comparatively common. The construction of buildings in soft clays has always been associated with stability problems and settlement. Shallow foundations inevitably results in large settlements which must be accommodated for in the design, and which invariably necessitate long-term maintenance of engineered facilities. The following relationship among N-values obtained from SPT, consistency and undrained shear strength of soft clays may be used as guides.

<u>N-value</u>	<u>Consistency</u>	<u>Undrained Shear Strength (kN/m²)</u>
Below 2	Very soft	Less than 20
2 – 4	Soft	20 – 40

Undrained shear strength is half of unconfined compressive strength as determined from unconfined compression test or half of the peak deviator stress as obtained from unconsolidated undrained (UU) triaxial compression test.

3.6 Materials

All materials for the construction of foundations shall conform to the requirements of Part 5 of this Code.

3.6.1 Concrete

All concrete materials and steel reinforcement used in foundations shall conform to the requirements specified in Chapter 5 unless otherwise specified in this Section. For different types of foundation the recommended concrete properties are shown in Table 6.3.5. However, special considerations should be given for hostile environment (salinity, acidic environment).

Table 6.3.5: Properties of Concrete for Different Types of Foundations

Foundation Type	Minimum cement content (kg/m ³)	Specified Min. 28 days Cylinder Strength (MPa)	Slump (mm)	Remarks
Footing/raft	350	20	25 to 125	Retarder and plasticizer
Drilled shaft/Cast-in-situ pile (tremie concrete)	400	18	125 to 200	recommended.
Driven pile	350	25	25 to 125	Slump test shall be performed as per ASTM C143.

3.6.2 Steel

All steel reinforcement and steel materials used in foundations shall conform to the requirements specified in Chapter 5 unless otherwise specified in this Section. However, this Section considers the corrosivity of soil that is described as under.

Corrosion in soil, water or moist out-door environment is caused by electro-chemical processes. The process takes place in corrosion cells on the steel surface, which consists of an anodic surface, a cathodic surface (where oxygen is reduced) and the electrolyte, which reacts with these surfaces. In the case of general corrosion, the surface erosion is relatively even across the entire surface. Local corrosion however is concentrated to a limited surface area. Pronounced cavity erosion is rather unusual on unprotected carbon steel in soil or water.

In many circumstances, steel corrosion rates are low and steel piles may be used for permanent works in an unprotected condition. The degree of corrosion and whether protection is required depend upon the working environment which can be variable, even within a single installation. Underground corrosion of steel piles driven into undisturbed soils is negligible irrespective of the soil type and characteristics. The insignificant corrosion attack is attributed to the low oxygen levels present in undisturbed soil. For the purpose of calculations, a maximum corrosion rate of 0.015

mm per side per year may be used. In recent-fill soils or industrial waste soils, where corrosion rates may be higher, protection systems should be considered.

(a) Atmospheric Corrosion

Atmospheric corrosion of steel of 0.035 mm/side per year may be used for most atmospheric environments.

(b) Corrosion in Fresh Water

Corrosion losses in fresh water immersion zones are generally lower than for sea water so the effective life of steel piles is normally proportionately longer. However, fresh waters are variable and no general advice can be given to quantify the increase in the length of life.

(c) Corrosion in Marine Environment

Marine environments may include several exposure zones with different aggressivity and different corrosion performance.

(i) Below the bed level: Where piles are below the bed level little corrosion occurs and the corrosion rate given for underground corrosion is applicable, that is, 0.015 mm/side per year.

(ii) Seawater immersion zone: Corrosion of steel piling in immersion conditions is normally low, with a mean corrosion rate of 0.035 mm/side per year.

(iii) Tidal zones: Marine growths in this zone give significant protection to the piling, by sheltering the steel from wave action between tides and by limiting the oxygen supply to the steel surface. The corrosion rate of steels in the tidal zone is similar to that of immersion zone corrosion, i.e. 0.035 mm/side per year. Protection should be provided where necessary, to the steel surfaces to prevent the removal or damage of the marine growth.

(iv) Low water zone: In tidal waters, the low water level and the splash zone are reasons of highest thickness losses, where a mean corrosion rate of 0.075 mm/side per year occurs. Occasionally higher corrosion rates are encountered at the lower water level because of specific local conditions.

(v) Splash and atmospheric zones: In the splash zone, which is a more aggressive environment than the atmospheric zone, corrosion rates are similar to the low water level, i.e. 0.075 mm/side per year. In this zone thick stratified rust layers may develop and at thicknesses greater than 10 mm this tend to spall from steel especially on curved parts of the piles such as the shoulders and the clutches. Rust has a much greater volume than the steel from which it is derived so that the steel corrosion losses are represented by some 10 % to 20 % of the rust thickness. The boundary between splash and atmospheric zones is not well defined, however, corrosion rates diminish rapidly with distance above peak wave height and mean atmospheric corrosion rate of 0.035 mm/side per year can be used.

(d) Method of Assessing Soil Corrosivity

The following variables attributes to accelerated corrosion: (i) acidity and alkalinity; (ii) soluble salts; (iii) bacteria (sulphates usually promote bacteria; (iv) resistivity; (v) moisture content; (vi) pH; and so on. The following charts, Tables 6.3.6a and 6.3.6b provide guides in assessing the corrosivity of soils. The parameters should be measured following relevant Standards of ASTM.

Table 6.3.6a: Soil Corrosivity Scores for Various Parameters

Item/Parameter	Measured value	Score/Mark
Soil composition	Calcareous, marly limestone, sandy marl, non-stratified sand	+2
	Sandy silt, sandy clay, clayey silt	0
	Clay, silty clay	-2
	Peat, marshy soil	-4
Ground water	None	0
	Exist	-1
	Vary	-2

Item/Parameter	Measured value	Score/Mark
Resistivity	10,000 ohm-cm or more	0
	10,000-5,000	-1
	5,000-2,300	-2
	2,300-1,000	-3
	1,000 or less	-4
Moisture content	20% or less	0
	More than 20%	-1
pH	6 or more	0
	Less than 6	-2
Sulphide and hydrogen sulphide	None	0
	Trace	-2
	Exist	-4
Carbonate	5% or more	+2
	5% - 1%	+1
	Less than 1%	0
Chloride	100 mg/kg or less	0
	More than 100 mg/kg	+1
Sulphate	200 mg/kg or less	0
	200 – 500 mg/kg	-1
	500 – 1000 mg/kg	-2
	More than 1000 mg/kg	-3
Cinder and coke	None	0
	Exist	-4

Table 6.3.6b: Soil Corrosivity Rating

Score/Mark	Corrosivity Rating
0 and above	Non-corrosive
0 to -4	Slightly corrosive
-5 to -10	Corrosive
-10 or less	Highly corrosive

(e) Methods of Increasing Effective Life

The effective life of unpainted or otherwise unprotected steel piling depends upon the combined effects of imposed stresses and corrosion. Where measures for increasing the effective life of a structure are necessary, the following should be considered; introduction of a corrosion allowance (i.e. oversized cross-sections of piles, high yield steel etc), anti-corrosion painting, application of a polyethylene (PE) coating (on steel tube piles), zinc coating, electro-chemical (cathodic) protection, casting in cement mortar or concrete, and use of atmospheric corrosion resistant steel products instead of ordinary carbon steel in any foundation work involving steel.

- (i) Use of a heavier section: Effective life may be increased by the use of additional steel thickness as a corrosion allowance. Maximum corrosion seldom occurs at the same position as the maximum bending moment. Accordingly, the use of a corrosion allowance is a cost effective method of increasing effective life. It is preferable to use atmospheric corrosion resistant high strength low alloy steel.
- (ii) Use of a high yield steel: An alternative to using mild steel in a heavier section is to use a higher yield steel and retain the same section.
- (iii) Zinc coatings: Steel piles should normally be coated under shop conditions. Paints should be applied to the cleaned surface by airless spraying and then cured rapidly to produce the required coating thickness in as few coats as possible. Hot zinc-coating of steel piles in soil can achieve normally long-lasting protection, provided that the zinc layer has sufficient thickness. In some soils, especially those with low pH-values, the corrosion of zinc can be high, thereby shortening the protection duration. Low pH-values occur normally in the aerated zone above the lowest ground water level. In such a case, it is recommended to apply protection paint on top of the zinc layer.

-
- (iv) Concrete encasement: Concrete encasement may be used to protect steel piles in marine environment. The use of concrete may be restricted to the splash zone by extending the concrete cope to below the mean high water level, both splash and tidal zones may be protected by extending the cope to below the lowest water level. The concrete itself should be a quantity sufficient to resist seawater attack.
 - (v) Cathodic protection: The design and application of cathodic protection systems to marine piles structures is a complex operation requiring the experience of specialist firms. Cathodic protection with electric current applied to steel sheet pile wall. Rod-type anodes are connected directly with steel sheet pile. Cathodic protection is considered to be fully effective only up to the half-tide mark. For zones above this level, including the splash zone, alternative methods of protection may be required, in addition to cathodic protection. Where cathodic protection is used on marine structures, provision should be made for earthing ships and buried services to the quay.
 - (vi) Polyethelene coating: Steel tube piles can be protected effectively by application of a PE-cover of a few millimeter of thickness. This cover can be applied in the factory and is usually placed on a coating of epoxy. Steel tube piles in water, where the mechanical wear is low, can in this way be protected for long time periods. When the steel tube piles with the PE-cover are driven into coarse-grained soil, the effect of damaging the protection layer must be taken into consideration.
 - (vii) Properly executed anti-corrosion measures, using high-quality methods can protect steel piles in soil or water over periods of 15 to 20 years. PE-cover in combination with epoxy coating can achieve even longer protection times.

3.6.3 Timber

Timber may be used only for foundation of temporary structure and shall conform to the standards specified in Sec 2.9 of Part 5 of this Code. Where timber is exposed to soil or used as load bearing pile above ground water level, it shall be treated in accordance with BDS 819:1975.

3.7 Types of Foundation

3.7.1 Shallow Foundations

Shallow foundations spread the load to the ground at shallow depth. Generally, the capacity of this foundation is derived from bearing.

3.7.2 Footing

Footings are foundations that spread the load to the ground at shallow depths. These include individual column footings, continuous wall footings, and combined footings. Footings shall be provided under walls, pilasters, columns, piers, chimneys etc. bearing on soil or rock, except that footings may be omitted under pier or monolithic concrete walls if safe bearing capacity of the soil or rock is not exceeded.

3.7.3 Raft/Mat

A foundation consisting of continuous slab that covers the entire area beneath the structure and supports all walls and columns is considered as a raft or mat foundation. A raft foundation may be one of the following types:

- (i) Flat plate or concrete slab of uniform thickness usually supporting columns spaced uniformly and resting on soils of low compressibility.
- (ii) Flat plates as in (a) but thickened under columns to provide adequate shear and moment resistance.
- (iii) Two way slab and beam system supporting largely spaced columns on compressible soil.
- (iv) Cellular raft or rigid frames consisting of slabs and basement walls, usually used for heavy structures.

3.7.4 Deep Foundations

A cylindrical/box foundation having a ratio of depth to base width greater than 5 is considered a Deep Foundation. Generally, its capacity is derived from friction and end bearing.

3.7.5 Driven Piles

A slender deep foundation unit made of materials such as steel, concrete, wood, or combination thereof, which is pre-manufactured and placed by driving, jacking, jetting or screwing and displacing the soil.

- (i) Driven Precast Concrete Piles: Pile structure capable of being driven into the ground and able to resist handling stresses shall be used for this category of piles.

- (ii) Driven Cast-in-situ Concrete Piles : A pile formed by driving a steel casing or concrete shell in one or more pieces, which may remain in place after driving or withdrawn, with the inside filled with concrete, falls in this category of piles. Sometimes an enlarged base may be formed by driving out a concrete plug.
- (iii) Driven Prestressed Concrete Pile: A pile constructed in prestressed concrete in a casting yard and subsequently driven in the ground when it has attained sufficient strength.
- (iv) Timber Piles: Structural timber (Sec 2.9 Part 5) shall be used as piles for temporary structures for directly transmitting the imposed load to soil. Driven timber poles are used to compact and improve the deposit.

3.7.6 Bored Piles/Cast-in-Situ Piles

A deep foundation of generally small diameter, usually less than 600 mm, constructed using percussion or rotary drilling into the soil. These are constructed by concreting bore holes formed by auguring, rotary drilling or percussion drilling with or without using bentonite mud circulation. Excavation or drilling shall be carried out in a manner that will not impair the carrying capacity of the foundations already in place or will not damage adjacent foundations. These foundations may be tested for capacity by load test or for integrity by sonic response or other suitable method. Under-reaming drilled piers can be constructed in cohesive soils to increase the end bearing.

3.7.7 Drilled Pier/Drilled Shafts

Drilled pier is a bored pile with larger diameter (more than 600 mm) constructed by excavating the soil or sinking the foundation.

3.7.8 Caisson/Well

A caisson or well foundation is a deep foundation of large diameter relative to its length that is generally a hollow shaft or box which is sunk to position. It differs from other types of deep foundation in the sense that it undergoes rigid body movement under lateral load, whereas the others are flexible like a beam under such loads. This type of foundation is usually used for bridges and massive structures.

Division B: Design of Foundations (Sections 3.8 to 3.11)

3.8 Shallow Foundation

This Section shall be applicable to isolated Footings, Combined Footings and Raft/Mats.

3.8.1 Distribution of Bearing Pressure

Footing shall be designed to keep the maximum imposed load within the safe bearing values of soil and rock. To prevent unequal settlement footing shall be designed to keep the bearing pressure as nearly uniform as practical. For raft design, distribution of soil pressures should be consistent with the properties of the foundation materials (subsoil) and the structure (raft thickness) and with the principles of geotechnical engineering.

Mat or raft and floating foundations shall only be used when the applied load of building or structure is so arranged as to result in practically uniformly balanced loading, and the soil immediately below the mat is of uniform bearing capacity.

3.8.2 Dimension of Footings

Footings shall generally be proportioned from the allowable bearing pressure and stress limitations imposed by limiting settlement.

The angle of spread of the load from the wall base to outer edge of the ground bearing shall not exceed the following:

Brick or stone masonry	$\frac{1}{2}$ horizontal to 1 vertical
Lime concrete	$\frac{2}{3}$ horizontal to 1 vertical
Cement concrete	1 horizontal to 1 vertical

A footing shall be placed to depth so that:

- adequate bearing capacity is achieved,
- in case of clayey soil, shrinkage and swelling due to seasonal weather change is not significant,
- it is below possible excavation close by, and
- it is at least 500 mm below natural ground level unless rock or other weather resistant material is at the surface.

Where footings are to be founded on a slope, the distance of the sloping surface at the base level of the footing measured from the centre of the footing shall not be less than twice the width of the footing.

When adjacent footings are to be placed at different levels, the distance between the edges of footings shall be such as to prevent undesirable overlapping of structures in soil and disturbance of the soil under the higher footing due to excavation of the lower footing.

On a sloping site, footing shall be on a horizontal bearing and stepped. At all changes of levels, footings shall be lapped for a distance of at least equal to the thickness of foundation or three times the height of step, whichever is greater. Adequate precautions shall be taken to prevent tendency for the upper layers of soil to move downhill.

3.8.3 Thickness of Footing

The minimum thickness for different types of footing for light structures (two stories or less in occupancy category A, B, C and D), shall be as follows:

<u>Type of Footing</u>	<u>Minimum Thickness</u>	<u>Remark</u>
Masonry	250 mm; twice the maximum projection from the face of the wall	Greater of the two values shall be selected
Plain concrete	200 mm, or twice the maximum offset in a stepped footing	-
Reinforced concrete	150 mm	Resting on soil
(depth above bottom reinforcement)	300 mm	Resting on pile

3.8.4 Footings in Fill Soil

Footings located in fill are subject to the same bearing capacity, settlement, and dynamic ground stability considerations as footings in natural soil. The behavior of both fill and underlying natural soil should be considered.

3.8.5 Soil and Rock Property Selection

Soil and rock properties defining the strength and compressibility characteristics of foundation materials are required for footing design. Foundation stability and settlement analysis for design shall be conducted using soil and rock properties based on the results of field and laboratory testing.

3.8.6 Minimum Depth of Foundation

The minimum depth of foundation shall be 1.5 m for exterior footing of permanent structures in cohesive soils and 2 m in cohesionless soils. For temporary structures the minimum depth of exterior footing shall be 400 mm. In case of expansive and soils susceptible to weathering effects, the above mentioned minimum depths will be not applicable and may have to be increased.

3.8.7 Scour

Footings supported on soil shall be embedded sufficiently below the maximum computed scour depth or protected with a scour countermeasure.

3.8.8 Mass Movement of Ground in Unstable Areas

In certain areas mass movement of ground may occur from causes independent of the loads applied to the foundation. These include mining subsidence, landslides on unstable slopes and creep on clay slopes. In areas of ground subsidence, foundations and structures should be made sufficiently rigid and strong to withstand the probable worst loading conditions. The construction of structures on slopes which are suspected of being unstable and subject to landslip shall be avoided. Spread foundations on such slopes shall be on a horizontal bearing and stepped. For foundations on clay slopes, the stability of the foundation should be investigated.

3.8.9 Foundation Excavation

Foundation excavation below ground water table particularly in sand shall be made such that the hydraulic gradient at the bottom of the excavation is not increased to a magnitude that would cause the foundation soils to loosen due to upward flow of water. Further, footing excavations shall be made such that hydraulic gradients and material removal do not adversely affect adjacent structures. Seepage forces and gradients may be evaluated by standard flow net procedures. Dewatering or cutoff methods to control seepage shall be used when necessary. In case of soil excavation for raft foundations, the following issues should be additionally taken into consideration:

- (i) Protection for the excavation using shore or sheet piles and/or retaining system with or without bracing, anchors etc.
- (ii) Consideration of the additional bearing capacity of the raft for the depth of the soil excavated.
- (iii) Consideration of the reduction of bearing capacity for any upward buoyancy pressure of water.
- (iv) Other considerations as mentioned in Sec 3.12.

3.8.10 Design Considerations for Raft foundation

Design provisions given in Sec 3.9.2 shall generally apply. In case the raft supports structure consisting of several parts with varying loads and height, it is advisable to provide separate joints between these parts. Joints shall also be provided wherever there is a change in the direction of the raft. The minimum depth of foundation shall generally be not less than 1.5 m in cohesive soil and 2 m in cohesionless soils. Foundations subject to heavy vibratory loads shall preferably be isolated.

3.8.10.1 Dimensioning

The size and shape of the foundation shall be decided taking into consideration the magnitude of subgrade modulus, the long term deformation of the supporting soil and the distribution of contact pressure.

Distribution of contact pressure underneath a raft is affected by the physical characteristics of the supporting soil. Consideration shall be given to the increased contact pressure developed along the edges of foundation on cohesive soils and the decrease in pressure on granular soils. Both long term and short term deformation and settlement effects shall be considered in the design.

3.8.10.2 Eccentricity

Since raft foundation usually occupies the entire area of a building, it may not be feasible to proportion the raft so that the centroid of the raft coincides with the line of action of the resultant force due to building. In such cases, the effect of eccentricity on the contact pressure distribution shall be considered in the design.

3.8.10.3 Rigidity of Foundation

The rigidity of foundation affects soil pressure distribution which in turn produces additional stresses in the raft due to moments etc. A rigid foundation also generates high secondary stresses. The effects of such rigidity shall be taken into consideration in designing rafts.

3.8.10.4 Methods of Analysis

The essential part of analysis of a raft foundation is the determination of distribution of contact pressure below the mat which is a complex function of the rigidity of raft, and the rigidity of the superstructure and the supporting soil. Any analytical method shall therefore use simplifying assumptions which are reasonably valid for the condition analysed. Choice of a particular method shall therefore be governed by the validity of the assumptions in the particular case.

3.9 Geotechnical Design of Shallow Foundations

3.9.1 General

Shallow foundations on soil shall be designed to support the design loads with adequate bearing and structural capacity and with tolerable settlements. In addition, the capacity of footings subjected to seismic and dynamic loads shall be appropriately evaluated. The location of the resultant pressure on the base of the footings should be maintained preferably within $B/6$ of the centre of the footing.

3.9.2 Design Load

- (a) Shallow foundation design considering bearing capacity due to shear strength shall consider the most unfavourable effect of the following combinations of loading:
- (i) Full Dead Load + Normal Live Load
 - (ii) Full Dead Load + Normal Live Load + Wind Load or Seismic Load
 - (iii) $0.9 \times (\text{Full Dead Load}) + \text{Buoyancy Pressure}$
- (b) Shallow foundation design considering settlement shall consider the most unfavourable effect of the following combinations of loading:

SAND

- (i) Full Dead Load + Normal Live Load
- (ii) Full Dead Load + Normal Live Load + Wind Load or Seismic Load

CLAY

Full Dead Load + $0.5 \times$ Normal Live Load

Normal Live Load is a live load considering floor area reduction factor as used in column design (Sec 2.3.13).

3.9.3 Bearing Capacity of Shallow Foundations

When physical characteristics such as cohesion, angle of internal friction, density etc. are available, the bearing capacity shall be calculated from stability considerations. Established bearing capacity equations shall be used for calculating bearing capacity.

A factor of safety of between 2.0 to 3.0 (depending on engineering judgement on the extent of soil exploration, quality control and monitoring of construction) shall be adopted to obtain allowable bearing pressure when dead load and normal live load is used. Thirty three percent (33%) overstressing above allowable pressure shall be allowed in case of design considering wind or seismic loading. Allowable load shall also limit settlement between supporting elements to a tolerable limit.

3.9.3.1 Presumptive bearing capacity for preliminary design

For lightly loaded and small sized structures (two storied or less in occupancy category A, B, C & D) and for preliminary design of any structure, the presumptive bearing values (allowable) as given in Table 6.3.7 may be assumed for uniform soil in the absence of test results.

3.9.3.2 Allowable increase of bearing pressure due to wind and earthquake forces

The allowable bearing pressure of the soil determined in accordance with this Section may be increased by 33 percent when lateral forces due to wind or earthquake act simultaneously with gravity loads. No increase in allowable bearing pressure shall be permitted for gravity loads acting alone. In a zone where seismic forces exist, possibility of liquefaction in loose sand, silt and sandy soils shall be investigated.

Table 6.3.7: Presumptive Values of Bearing Capacity for Lightly Loaded Structures*

Soil Type	Soil Description	Safe Bearing Capacity, kPa
1	Soft Rock or Shale	440
2	Gravel, sandy gravel, silty sandy gravel; very dense and offer high resistance to penetration during excavation (soil shall include the groups GW, GP, GM, GC)	400**
3	Sand (other than fine sand), gravelly sand, silty sand; dry (soil shall include the groups SW, SP, SM, SC)	200**
4	Fine sand; loose & dry (soil shall include the groups SW, SP)	100**

5	Silt, clayey silt, clayey sand; dry lumps which can be easily crushed by finger (soil shall include the groups ML, SC & MH)	150
6	Clay, sandy clay; can be indented with strong thumb pressure (soil shall include the groups CL & CH)	150
7	Soft clay; can be indented with modest thumb pressure (soil shall include the groups CL & CH)	100
8	Very soft clay; can be penetrated several centimeters with thumb pressure (soil shall include the groups CL & CH)	50
9	Organic clay & Peat (soil shall include the groups OH, OL, Pt)	To be determined after investigation.
10	Fills	To be determined after investigation.

* Two stories or less (Occupancy category A, B, C and D)

** 50% of these values shall be used where water table is above the base, or below it within a distance equal to the least dimension of foundation

3.9.4 Settlement of Shallow Foundation

Foundation shall be so designed that the allowable bearing capacity is not exceeded, and the total and differential settlement are within permissible values. Foundations can settle in various ways and each affects the performance of the structure. The simplest mode consists of the entire structure settling uniformly. This mode does not distort the structure. Any damage done is related to the interface between the structure and adjacent ground or adjacent structures. Shearing of utility lines could be a problem. Another possibility is that one side of the structure settles much more than the opposite side and the portions in between settle proportionately. This causes the structure to tilt, but it still does not distort. A nominal tilt will not affect the performance of the structure, although it may create aesthetic and public confidence problems. However, as a result of difference in foundation settlement the structure may settle and distort causing cracks in walls and floors, jamming of doors and windows and overloading of structural members.

3.9.4.1 Total settlement

Total settlement (δ) is the absolute vertical movement of the foundation from its as-constructed position to its loaded position. Total settlement of foundation due to net imposed load shall be estimated in accordance with established engineering principle. An estimate of settlement with respect to the following shall be made.

- (i) Elastic compression of the underlying soil below the foundation and of the foundation.
- (ii) Consolidation settlement.
- (iii) Secondary consolidation/compression of the underlying soil.
- (iv) Compression and volume change due to change in effective stress or soil migration associated with lowering or movement of ground water.
- (v) Seasonal swelling and shrinkage of expansive clays.
- (vi) Ground movement on earth slopes, such as surface erosion, creep or landslide.
- (vii) Settlement due to adjacent excavation, mining subsidence and underground erosion.

In normal circumstances of inorganic and organic soil deposits the total settlement is attributed due to the first three factors as mentioned above. The other factors are regarded as special cases. Because soil settlement can have both time-dependent and notime-dependent components, it is often categorized in terms short-term settlement (or immediate settlement) which occurs as quickly as the load is applied, and long-term settlement (or delayed settlement), which occurs over some longer period. Many engineers associate consolidation settlement solely with the long term settlement of clay. However, this is not strictly true. Consolidation is related to volume change due to change in effective stress regardless of the type of soil or the time required for the volume change.

3.9.4.2 Elastic/distortion settlement

Elastic Settlement δ_e of foundation soils results from lateral movements of the soil without volume change in response to changes in effective vertical stress. This is non-time dependent phenomenon and similar to the Poisson's effect where an object is loaded in the vertical direction expands laterally. Elastic or distortion settlements primarily occur when the load is confined to a small area, such as a structural foundation, or near the edges of large loaded area such as embankments.

3.9.4.3 Immediate settlement/short term settlement

This vertical compression occurs immediately after the application of loading either on account of elastic behaviour that produces distortion at constant volume and on account of compression of air void. This is sometimes designated as δ_i for sandy soil, even the consolidation component is immediate.

3.9.4.4 Primary consolidation settlement

Primary consolidation settlement or simply the consolidation settlement δ_c of foundation is due to consolidation of the underlying saturated or nearly saturated soil especially cohesive silt or clay. The full dead load and 50% of total live load shall be considered when computing the consolidation settlement of foundations on clay soils.

3.9.4.5 Secondary consolidation settlement

Secondary consolidation settlement δ_s of the foundation is due to secondary compression or consolidation of the underlying saturated or nearly saturated cohesive silt or clay. This is primarily due to particle re-orientation, creep, and decomposition of organic materials. Secondary compression is always time-dependent and can be significant in highly plastic clays, organic soils, and sanitary landfills, but it is negligible in sands and gravels.

3.9.4.6 Differential settlement

Differential settlement is the difference in total settlement between two foundations or two points in the same foundation. It occurs as a result of relative movement between two parts of a building. The related terms describing the effects of differential settlement on the structural as a whole or on parts of it are tilt, rotation and angular distortion/relative rotation which are defined below. Due consideration shall be given to estimate the differential settlement that may occur under the building structure under the following circumstances:

- (i) Non-uniformity in subsoil formation within the area covered by the building due to geologic or man-made causes, or anomalies in type, structure, thickness and density of the formation.
- (ii) Non-uniform pressure distribution due to non-uniform and incomplete loading.
- (iii) Ground water condition during and after construction.
- (iv) Loading influence of adjacent structures.
- (v) Uneven expansion and contraction due to moisture migration, uneven drying, wetting or softening.

3.9.4.7 Rotation and tilt of shallow foundation

(a) Rotation

Rotation is the angle between the horizontal line and an imaginary straight line connecting any two foundations or two points in a single foundation.

(b) Tilt

Tilt is rotation of the entire superstructure or a well-defined part of it as a result of non-uniform or differential settlement of foundation as a result of which one side of the building settles more than the other thus affecting the verticality of the building.

(c) Angular Distortion/Relative Rotation

Angular distortion or relative rotation is the angle between imaginary straight line indicating the overall tilt of a structure and the imaginary connecting line indicating the inclination of a specific part of it. It is measured as the ratio of differential settlement to the distance between the two points.

(d) Tolerable Settlement, Tilt and Rotation

Allowable or limiting settlement of a building structure will depend on the nature of the structure, the foundation and the soil. Different types of structures have varying degrees of tolerance to settlements and distortions. These variations depend on the type of construction, use of the structure, rigidity of the structure and the presence of sensitive finishes. As a general rule, a total settlement of 25 mm and a differential settlement of 20 mm between columns in most buildings shall be considered safe for buildings on isolated pad footings on sand for working load (un-factored). A total settlement of 40 mm and a differential settlement of 20 mm between columns shall be considered safe for buildings on isolated pad footings on clay soil for working load. Buildings on raft can usually tolerate greater total settlements. Limiting tolerance for distortion and deflections introduced in a structure is necessarily a subjective process, depending on the status of the building and any specific requirements for serviceability. The limiting values, given in Table 6.3.8 may be followed as guidelines.

Table 6.3.8: Permissible Total Settlement, Differential Settlement and Angular Distortion (Tilt) for Shallow Foundations in Soils (in mm) (Adapted from NBCI, 2005)

Type of Structure	Isolated Foundations						Raft Foundation					
	Sand and Hard Clay			Plastic Clay			Sand and Hard Clay			Plastic Clay		
	Maximum Settlement	Differential Settlement	Angular Distortion	Maximum Settlement	Differential Settlement	Angular Distortion	Maximum Settlement	Differential Settlement	Angular Distortion	Maximum Settlement	Differential Settlement	Angular Distortion
Steel Structure	50	0.0033 L	1/300	50	0.0033 L	1/300	75	0.0033 L	1/300	100	0.0033 L	1/300
RCC Structures	50	0.0015 L	1/666	75	0.0015 L	1/666	75	0.0021 L	1/500	100	0.002 L	1/500
Multistoried Building												
(a) RCC or steel framed building with panel walls	60	0.002 L	1/500	75	0.002 L	1/500	75	0.0025 L	1/400	125	0.0033 L	1/300
(b) Load bearing walls												
(i) L/H = 2 *	60	0.0002 L	1/5000	60	0.0002 L	1/5000	Not likely to be encountered					
(ii) L/H = 7 *	60	0.0004 L	1/2500	60	0.0004 L	1/2500	Not likely to be encountered					
Silos	50	0.0015 L	1/666	75	0.0015 L	1/666	100	0.0025 L	1/400	125	0.0025 L	1/400
Water Tank	50	0.0015 L	1/666	75	0.0015 L	1/666	100	0.0025 L	1/400	125	0.0025 L	1/400
Notes: The values given in the Table may be taken only as a guide and the permissible total settlement, differential settlement and tilt (angular distortion) in each case should be decided as per requirements of the designer. L denotes the length of deflected part of wall/ raft or centre to centre distance between columns. H denotes the height of wall from foundation footing. * For intermediate ratios of L/H, the values can be interpolated.												

3.9.5 Dynamic Ground Stability or Liquefaction Potential for Foundation Soils

Soil liquefaction is a phenomenon in which a saturated soil deposit loses most, if not all, of its strength and stiffness due to the generation of excess pore water pressure during earthquake-induced ground shaking. It has been a major cause for damage of structures during past earthquakes (e.g., 1964 Niigata Earthquake). Current knowledge of liquefaction is significantly advanced and several evaluation methods are available. Hazards due to liquefaction are routinely evaluated and mitigated in seismically active developed parts of the world.

Liquefaction can be analyzed by a simple comparison of the seismically induced shear stress with the similarly expressed shear stress required to cause initial liquefaction or whatever level of shear strain amplitude is deemed intolerable in design. Usually, the occurrence of 5% double amplitude (DA) axial strain is adopted to define the cyclic strength consistent with 100% porewater pressure build-up. The corresponding strength (CRR) can be obtained by several procedures. Thus, the liquefaction potential of a sand deposit is evaluated in terms of factor of safety F_L , defined as in Eq. 6.3.6. The externally applied cyclic stress ratio (CSR) can be evaluated using Equations 6.3.7a, 6.3.7b and 6.3.8.

$$F_L = \frac{CRR}{CSR} \quad (6.3.6)$$

If the factor of safety F_L is ≤ 1 , liquefaction is said to take place. Otherwise, liquefaction does not occur. The factor of safety obtained in this way is generally used to identify the depth to which liquefaction is expected to occur in a future earthquake. This information is necessary if countermeasure is to be taken in an in situ deposit of sands.

The cyclic shear stress induced at any point in level ground during an earthquake due to the upward propagation of shear waves can be assessed by means of a simple procedure proposed. If a soil column to a depth z is assumed to move horizontally and if the peak horizontal acceleration on the ground surface is a_{max} , the maximum shear stress τ_{max} acting at the bottom of the soil column is given by

$$\tau_{max} = a_{max} r_d (\gamma_t)(z/g) \quad (6.3.7a)$$

$$r_d = 1 - 0.015z \quad (6.3.7b)$$

Where, γ_t is unit weight of the soil, g is the gravitational acceleration, z is the depth and r_d is a stress reduction coefficient to allow for the deformability of the soil column ($r_d < 1$). It is recommended to use the empirical formula given in Eq. 6.3.7b to compute stress reduction coefficient r_d , where z is in meters. Division of both sides of Eq. 6.3.7a by the effective vertical stress σ'_v gives

$$CSR = \frac{\tau_{max}}{\sigma'_v} = \frac{a_{max}}{g} r_d \frac{\sigma_v}{\sigma'_v} \quad (6.3.8)$$

Where, $\sigma_v = \gamma_t z$ is the total vertical stress. Eq. 6.3.8 has been used widely to assess the magnitude of shear stress induced in a soil element during an earthquake. The peak ground acceleration, a_{max} should be taken from seismic zoning map. One of the advantages of Eq. 6.3.8 is that all the vast amount of information on the horizontal accelerations that has ever been recorded on the ground surface can be used directly to assess the shear stress induced by seismic shaking in the horizontal plane within the ground.

The second step is to determine the cyclic resistance ratio (CRR) of the in situ soil. The cyclic resistance ratio represents the liquefaction resistance of the in situ soil. The most commonly used method for determining the liquefaction resistance is to use the data obtained from the standard penetration test. A cyclic triaxial test may also be used to estimate CRR more accurately. Site response analysis of a site may be carried out to estimate the site amplification factor. For this purpose, dynamic parameters such as shear modulus and damping factors need to be estimated. The site amplification factor is required to estimate a_{max} for a given site properly. The following points are to be noted as regards to soil liquefaction:

- Sandy and silty soils tend to liquefy; clay soils do not undergo liquefaction except the sensitive clays.
- Resistance to liquefaction of sandy soil depends on fine content. Higher the fine content lower is the liquefaction potential.
- As a rule of thumb, any soil that has a SPT value higher than 30 will not liquefy.

Fine grained soils (silty clays/ clayey silt) are susceptible to liquefaction if (Finn et. al., 1994):

- Fraction finer than 0.005 mm $\leq 10\%$
- Liquid limit (LL) $\leq 36\%$
- Natural water content $\leq 0.9 \times LL$
- Liquidity index ≤ 0.75

3.9.6 Structural Design of Shallow Foundations

The foundation members should have enough strength to withstand the stresses induced from soil-foundation interaction. The following important factors should be considered in the structural design of foundations.

3.9.6.1 Loads and reactions

Footings shall be considered as under the action of downward forces, due to the superimposed loads, resisted by an upward pressure exerted by the foundation materials and distributed over the area of the footings as determined by the eccentricity of the resultant of the downward forces. Where piles are used under footings, the upward reaction of the foundation shall be considered as a series of concentrated loads applied at the pile centers, each pile being assumed to carry the computed portion of the total footing load.

3.9.6.2 Isolated and multiple footing reactions

When a single isolated footing supports a column, pier or wall, the footing shall be assumed to act as a cantilever element. When footings support more than one column, pier, or wall, the footing slab shall be designed for the actual conditions of continuity and restraint.

3.9.6.3 Raft foundation reactions

For determining the distribution of contact pressure below a raft it is analyzed either as a rigid or flexible foundation considering the rigidity of the raft, and the rigidity of the superstructure and the supporting soil. Consideration shall be given to the increased contact pressure developed along the edges of raft on cohesive soils and the decrease in contact pressure along the edges on granular soils. Any appropriate analytical method reasonably valid for the condition may be used. Choice of a particular method shall be governed by the validity assumptions used. Numerical analysis of rafts using appropriate software may also be used for determination of reactions, shears and moments.

Both analytical (based on beams on elastic foundation, Eq. 6.3.9) and numerical methods require values of the modulus of subgrade reaction of the soil. For use in preliminary design, indicative values of the modulus of subgrade reaction (k) for cohesionless soils and cohesive soils are shown in Tables 6.3.9a and 6.3.9b, respectively.

$$k = 0.65 \cdot \left(\frac{E_s B^4}{EI} \right)^{1/12} \cdot \frac{E_s}{(1-\mu^2)} \cdot \frac{1}{B} \quad (6.3.9)$$

Where, E_s = Modulus of elasticity of soil; EI = Flexural rigidity of foundation; B = Width of foundation; μ = Poisson's ratio of soil.

Table 6.3.9a: Modulus of Subgrade Reaction (k) for Cohesionless Soils

Soil Characteristic		*Modulus of Sub-grade Reaction (k) of Soil (kN/m ³)	
Relative Density	Standard Penetration Test Value (N) (Blows per 300 mm)	For Dry or Moist State	For Submerged State
Loose	<10	15000	9000
Medium	10 to 30	15000 to 47000	9000 to 29000
Dense	30 and over	47000 to 180000	29000 to 108000

*The above values apply to a square plate 300 mm x 300 mm or beams 300 mm wide.

Table 6.3.9b: Modulus of Subgrade Reaction (k) for Cohesive Soils

Soil Characteristic		Modulus of Subgrade Reaction, k (kN/m ³)
Consistency	Unconfined Compressive Strength (kN/m ²)	
Stiff	100 to 200	27000
Very Stiff	200 to 400	27000 to 54000
Hard	400 and over	54000 to 108000

* The values apply to a square plate 300 mm x 300 mm. The above values are based on the assumption that the average loading intensity does not exceed half the ultimate bearing capacity.

3.9.6.4 Critical section for moment

External moment on any section of a footing shall be determined by passing a vertical plane through the footing and computing the moment of the forces acting over the entire area of the footing on one side of that vertical plane. The critical section for bending shall be taken at the face of the column, pier, or wall. In the case of columns that are not square or rectangular, the section shall be taken at the side of the concentric square of equivalent area. For footings under masonry walls, the critical section shall be taken halfway between the middle and edge of the wall. For footings under metallic column bases, the critical section shall be taken halfway between the column face and the edge of the metallic base. For mat foundations and combined footings critical section should be determined on the basis of maximum positive and negative moments obtained from soil-foundation interaction.

3.9.6.5 Critical section for shear

Computation of shear in footings, and location of critical section shall be in accordance with relevant sections of the structural design part of the Code. Location of critical section shall be measured from the face of column, pier or wall, for footings supporting a column, pier, or wall. For footings supporting a column or pier with metallic base plates, the critical section shall be measured from the location defined in the critical section for moments for footings.

3.9.6.6 Critical section for footings on driven piles/bored piles/drilled piers

Shear on the critical section shall be in accordance with the following. Entire reaction from any driven pile or bored piles, and drilled pier whose center is located $d_p/2$ (d_p = diameter of the pile) or more outside the critical section shall be considered as producing shear on that section. Reaction from any driven pile or drilled shaft whose center is located $d_p/2$ or more inside the critical section shall be considered as producing no shear on that section. For the intermediate position of driven pile or

drilled shaft centers, the portion of the driven pile or shaft reaction to be considered as producing shear on the critical section shall be based on linear interpolation between full value at $d_p/2$ outside the section and zero value at $d_p/2$ inside the section.

3.9.6.7 Transfer of Forces at the Base of Column.

All forces and moments applied at base of column or pier shall be transferred to top of footing. If the strength of concrete of footing is less than that of column, then bearing stress of footing concrete and reinforcement should be checked against imposed loading.

Lateral forces shall be transferred to supporting footing in accordance with shear transfer provisions of the relevant sections of the structural design part of the Code.

Bearing on concrete at contact surface between supporting and supported member shall not exceed concrete bearing strength for either surface.

3.9.6.8 Reinforcement

Reinforcement shall be provided across interface between supporting and supported member either by extending main longitudinal reinforcement into footings or by dowels. Reinforcement across interface shall be sufficient to satisfy all of the following:

- (i) Reinforcement shall be provided to transfer all force that exceeds concrete bearing strength in supporting and supported member.
- (ii) If it is required that loading conditions include uplift, total tensile force shall be resisted by reinforcement only.
- (iii) Area of reinforcement shall not be less than 0.005 times gross area of supported member (column) with a minimum of 4 bars.
- (iv) Minimum reinforcement of footing and raft shall be governed by temperature and shrinkage reinforcement as per Sec 8.1.11 Chapter 8 of this Part.

Reinforcement of square footings shall be distributed uniformly across the entire width of footing. Reinforcement of rectangular footings shall be distributed uniformly across the entire width of footing in the long direction. In the short direction, the portion of the total reinforcement given by the following equation shall be distributed uniformly over a band width (centered on center line of column or pier) equal to the length of the short side of the footing.

$$\frac{\text{Reinforcement in band width}}{\text{Total reinforcement in short direction}} = \frac{2}{(\beta+1)} \quad (6.3.10)$$

Here, β is the ratio of the footing length to width. The remainder of reinforcement required in the short direction shall be distributed uniformly outside the center band width of footing.

3.9.6.9 Development length and splicing

Computation of development length of reinforcement in footings shall be in accordance with the relevant sections of the structural design part of the Code.

For transfer of force by reinforcement, development length of reinforcement in supporting and supported member required splicing shall be in accordance with the relevant sections (Part. 6, Chapters 6 and 8) of the structural design part of the Code. Critical sections for development length of reinforcement shall be assumed at the same locations as defined above as the critical section for moments and at all other vertical planes where changes in section or reinforcement occur.

3.9.6.10 Dowel size

Diameter of dowels, if used, shall not exceed the diameter of longitudinal reinforcements.

3.10 Geotechnical Design of Deep Foundations

3.10.1 Driven Precast Piles

The provisions of this article shall apply to the design of axially and laterally loaded driven piles in soil. Driven pile foundation shall be designed and installed on the basis of a site investigation report that will include subsurface exploration at locations and depths sufficient to determine the position and adequacy of the bearing soil unless adequate data is available upon which the design and installation of the piles can be based. The report shall include:

- (i) Recommended pile type and capacities
- (ii) Driving and installation procedure
- (iii) Field inspection procedure
- (iv) Requirement of pile load test
- (v) Durability and quality of pile material
- (vi) Designation of bearing stratum or strata

A plan showing clearly the designation of all piles by an identifying system shall be filed prior to installation of such piles. All detailed records for individual piles shall bear an identification corresponding to that shown on the plan. A copy of such plan shall be available at the site for inspection at all times during the construction.

The design and installation of driven pile foundations shall be under the direct supervision of a competent geotechnical/foundation engineer who shall certify that the piles as installed satisfy the design criteria.

3.10.1.1 Application

Pile driving may be considered when footings cannot be founded on granular or stiff cohesive soils within a reasonable depth. At locations where soil conditions would normally permit the use of spread footings but the potential for scour exists, piles may be driven as a protection against scour. Piles may also be driven where an unacceptable amount of settlement of spread footings may occur.

3.10.1.2 Materials

Driven piles may be cast-in-place concrete, pre-cast concrete, pre-stressed concrete, timber, structural steel sections, steel pipe, or a combination of materials.

3.10.1.3 Penetration

Pile penetration shall be determined based on vertical and lateral load capacities of both the pile and subsurface materials. In general, the design penetration for any pile shall be not less than 3D into a hard cohesive or a dense granular material, and not less than 6D into a soft cohesive or loose a granular material.

3.10.1.4 Estimated pile length

Estimated pile lengths of driven piles shall be shown on the drawing and shall be based upon careful evaluation of available subsurface information, axial and lateral capacity calculations, and/or past experience. The maximum length/diameter ratio should not exceed 50 for a single segmental pile.

3.10.1.5 Types of driven piles

Driven piles shall be classified as "friction" or "end bearing" or a combination of both according to the manner in which load transfer is developed. The ultimate load capacity of a pile consists of two parts. One part is due to friction called skin friction or shaft friction or side shear, and the other is due to end bearing at the base or tip of the pile. If the skin friction is greater than about 80% of the end bearing load capacity, the pile is deemed a friction pile and, if the reverse, an end bearing pile. If the end bearing is neglected, the pile is called a "floating pile".

3.10.1.6 Batter piles

When the lateral resistance of the soil surrounding the piles is inadequate to counteract the horizontal forces transmitted to the foundation, or when increased rigidity of the entire structure is required, batter piles should be used in the foundation. Where negative skin friction loads are expected, batter piles should be avoided, and an alternate method of providing lateral restraint should be used.

Free standing batter piles are subject to bending moments due to their own weight, or external forces from other sources. Batter piles in loose fill or consolidating deposits may become laterally loaded due to settlement of the surrounding soil. In consolidating clay, special precautions, like provision of permanent casing, shall be taken.

3.10.1.7 Selection of soil and rock properties

Soil and rock properties defining the strength and compressibility characteristics of the foundation materials, are required for driven pile design.

3.10.1.8 Pile driving equipment

The pile driving process needs to fulfil assumptions and goals of the design engineer just as much as the design process has to foresee the conception and installation of the pile at the site. This is only possible through the selection of the right driving equipment especially hammer with proper assembly mounted on the most suitable leader, operated according to the specified practices of installation that consists of a series of principle and subsidiary procedures.

There are three principal methods of installing precast displacement piles: jacking, vibratory driving and driving. Jacking is comparatively new method and vibratory driving is suitable to limited soil and pile types (e.g. loose saturated sand, sheet piles). The most common method of installing displacement piles is by driving the piles into the ground by blows of an impact hammer. Because of this, piles installed in this manner are referred to as driven piles. An efficient method of installation requires proper use of the equipment for driving.

The pile driving equipment mainly consists of the components like pile hammer, pile driving leader and driving system components like anvil, cap block, driving head, follower, pile cushion etc. The key to efficient pile driving is a good match of the pile with the hammer and the other system components. Mismatches, often result either inability to drive the pile as specified or in pile damage. A brief account of pile driving equipment especially related to driving by impact hammers is provided in Appendix-F.

3.10.1.9 Design capacity of driven precast pile

The design pile capacity is the maximum load that the driven pile shall support with tolerable movement. In determining the design pile capacity the following items shall be considered:

- (i) Ultimate geotechnical capacity (axial and lateral).
- (ii) Structural capacity of pile section (axial and lateral).
- (iii) The allowable axial load on a pile shall be the least value of the above two capacities.

In determining the design axial capacity, consideration shall be given to the following:

- (i) The influence of fluctuations in the elevation of ground water table on capacity.
- (ii) The effects of driving piles on adjacent structure and slopes.
- (iii) The effects of negative skin friction or down loads from consolidating soil and the effects of lift loads from expansive or swelling soils.
- (iv) The influence of construction techniques such as augering or jetting on pile capacity.
- (v) The difference between the supporting capacity single pile and that of a group of piles.
- (vi) The capacity of an underlying strata to support load of the pile group.
- (vii) The possibility of scour and its effect on axial lateral capacity.

3.10.1.10 Ultimate Geotechnical Capacity of Driven Precast Pile for Axial Load

The ultimate load capacity, Q_{ult} , of a pile consists of two parts. One part is due to friction called skin friction or shaft friction or side shear, Q_s and the other is due to end bearing at the base or tip of the pile, Q_b . The ultimate axial capacity (Q_{ult}) of driven piles shall be determined in accordance with the following for compression loading.

$$Q_{ult} = Q_s + Q_b - W \quad (6.3.11)$$

For uplift loading;

$$Q_{ult} \leq 0.7Q_s + W \quad (6.3.12)$$

The allowable or working axial load shall be determined as:

$$Q_{allow} = Q_{ult}/FS \quad (6.3.13)$$

Where, W is the weight of the pile and FS is a gross factor of safety as suggested in Tables 6.3.10a and 6.3.10b. Often, for compression loading, the weight term is neglected if the weight, W , is considered in estimating imposed loading. The ultimate bearing capacity (skin friction and/or end bearing) of a single vertical pile may be determined by any of the following methods.

- (i) By the use of static bearing capacity equations
- (ii) By the use of SPT and CPT
- (iii) By load tests
- (iv) By dynamic methods

3.10.1.11 Static bearing capacity equations for driven precast pile capacity

The skin friction, Q_s and end bearing Q_b can be calculated as:

$$Q_s = A_s f_s \quad (6.3.14a)$$

$$Q_b = A_b f_b \quad (6.3.14b)$$

Where, A_s = skin friction area (perimeter area) of the pile = Perimeter \times Length

f_s = skin frictional resistance on unit surface area of pile that depends on soil properties and loading conditions (drained or undrained)

A_b = end bearing area of the pile = Cross-sectional area of pile tip (bottom)

f_b = end bearing resistance on unit tip area of pile, that depends on soil properties to a depth of $2B$ (B is the diameter for a circular pile section or length of sides for a square pile section) from the pile tip and loading conditions (drained or undrained)

For a layered soil system containing n number of layers, end bearing resistance can be calculated considering soil properties of the layer at which the pile rests, and the skin friction resistance considers all the penetrating layers calculated as:

$$Q_s = \sum_{i=1}^n \Delta Z_i \times (Perimeter)_i \times (f_s)_i \quad (6.3.15)$$

Where, ΔZ_i represents the thickness of any i^{th} layer and $(Perimeter)_i$ is the perimeter of the pile in that layer. The manner in which skin friction is transferred to the adjacent soil depends on the soil type. In fine-grained soils, the load transfer is nonlinear and decreases with depth. As a result, elastic compression of the pile is not uniform; more compression occurs on the top part than on the bottom part of the pile. For coarse-grained soils, the load transfer is approximately linear with depth (higher loads at the top and lower at the bottom).

In order to mobilize skin friction and end bearing, some movement of the pile is necessary. Field tests revealed that to mobilize the full skin friction a vertical displacement of 5 to 10 mm is required. The actual vertical displacement depends on the strength of soil and is independent of the pile length and diameter. The full end bearing resistance is mobilized in driven piles when the vertical displacement is about 10% of the pile tip diameter. For bored piles or drilled shafts, a vertical displacement of about 30% of the pile tip diameter is required. The full end bearing resistance is mobilized when slip or failure zones similar to shallow foundations are formed. The end bearing resistance can then be calculated by analogy with shallow foundations. The important bearing capacity factor is N_q .

The full skin friction and full end bearing are not mobilized at the same displacement. The skin friction is mobilized at about one-tenth of the displacement required to mobilize the end bearing resistance. This is important in deciding on the factor of safety to be applied to the ultimate load. Depending on the tolerable settlement, different factors of safety can be applied to skin friction and to end bearing.

Generally, piles driven into loose, coarse-grained soils tend to density the adjacent soil. When piles are driven into dense, coarse-grained soils, the soil adjacent to the pile becomes loose. Pile driving usually remolds fine-grained soils near the pile shaft. The implication of pile installation is that the intact shear strength of the soil is changed and one must account for this change in estimations of the load capacity.

3.10.1.12 Axial capacity of driven precast pile in cohesive soil using static bearing capacity equations

The ultimate axial capacity of driven piles in cohesive may be calculated from static formula, given by Equations 6.3.14a, 6.3.14b and 6.3.15, using a total stress method for undrained loading conditions, or an effective stress method for drained loading conditions. Appropriate values of adhesion factor (α) and coefficient of horizontal soil stress (k_s) for cohesive soils that are consistent with soil condition and pile installation procedure may be used. There are basically two approaches for calculating skin friction:

- (i) The α -method that is based on total stress analysis and is normally used to estimate the short term load capacity of piles embedded in fine grained soils. In this method, a coefficient α is used to relate the undrained shear strength c_u or s_u to the adhesive stress (f_s) along the pile shaft. As such,

$$Q_s = \alpha c_u A_s \quad (6.3.16)$$

$$\alpha = 1.0 \quad \text{for clays with } c_u \leq 25 \text{ kN/m}^2$$

$$\alpha = 0.5 \quad \text{for clays with } c_u \geq 70 \text{ kN/m}^2$$

$$\alpha = 1 - \left(\frac{c_u - 25}{70} \right) \quad \text{for clays with } 25 \text{ kN/m}^2 < c_u < 70 \text{ kN/m}^2$$

The end bearing in such a case is found by analogy with shallow foundations and is expressed as:

$$Q_b = (c_u)_b (N_c)_b A_b \quad (6.3.17)$$

N_c is a bearing capacity factor and for deep foundation the value is usually 9. c_u is the undrained shear strength of soil at the base of the pile. The suffix 'b's are indicatives of base of pile. The general equation for N_c is, however, as follows.

$$N_c = 6 \left[1 + 0.2 \left(\frac{L}{D_b} \right) \right] \leq 9 \quad (6.3.18)$$

D_b represents the diameter of the pile at base and L is the total length of pile. The skin friction value, $f_b = (c_u)_b (N_c)_b$ should not exceed 4.0 MPa.

- (ii) The β -method is based on an effective stress analysis and is used to determine both the short term and long term pile load capacities. The friction along the pile shaft is found using Coulomb's friction law, where the friction stress is given by $f_s = \mu \sigma'_x = \sigma'_x \tan \phi'$. The lateral effective stress, σ'_x is proportional to vertical effective stress, σ'_z by a co-efficient, K . As such,

$$f_s = K \sigma'_z \tan \phi' = \beta \sigma'_z \quad (6.3.19a)$$

Where,

$$\beta = K \tan \phi' = K_o \tan \phi' = (1 - \sin \phi') \sqrt{OCR} \quad (6.3.19b)$$

ϕ' is the effective angle of internal friction of soil and OCR is the over-consolidation ratio. For normally consolidated clay, β varies from 0.25 to 0.29. The value of β decreases for a very long pile, as such a correction factor is used.

$$\text{Correction factor for } \beta = \log \left(\frac{180}{L} \right) \geq 0.5 \quad (6.3.19c)$$

The end bearing capacity is calculated by analogy with the bearing capacity of shallow footings and is determined from:

$$f_b = (\sigma'_v)_b (N_q)_b \quad (6.3.20)$$

Where, N_q is a bearing capacity factor that depends on angle of internal friction ϕ' of the soil at the base of the pile, as presented in Figure 6.3.2. Subscript “b” designates the parameters at the base soil.

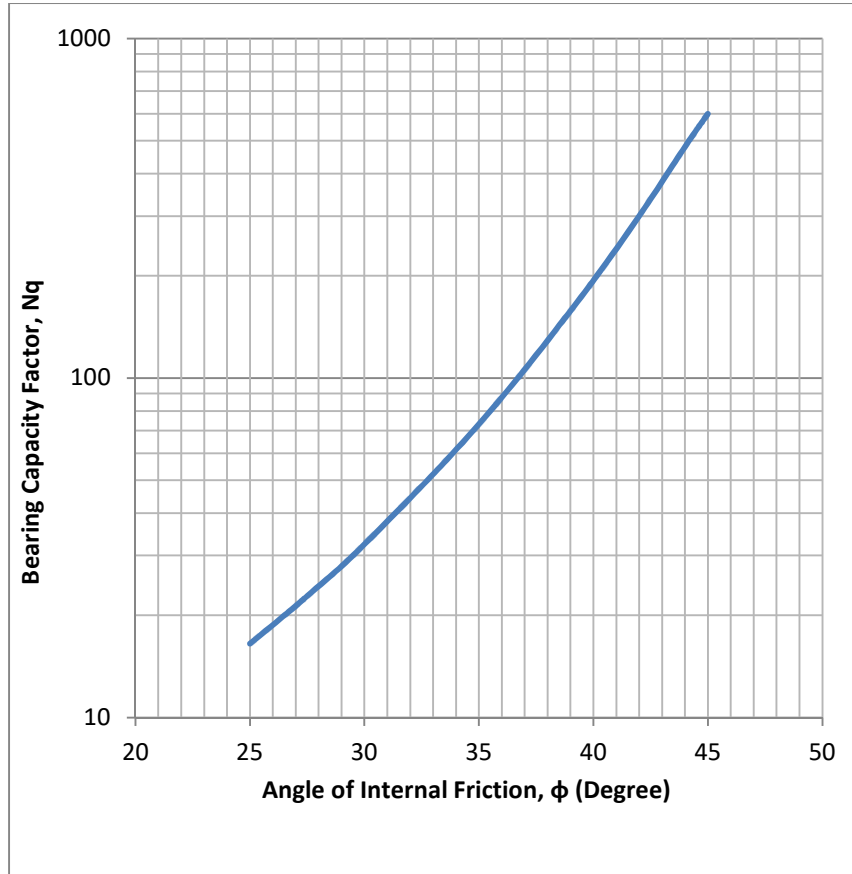


Figure 6.3.2 Bearing capacity factor N_q for deep foundation (After Berezantzev et. al. 1961)

3.10.1.13 Axial Capacity of driven precast pile in cohesive soil using SPT values

Standard Penetration Test N-value is a measure of consistency of clay soil and indirectly the measure of cohesion. The skin friction of pile can thus be estimated from N-value. The following relation may be used for preliminary design of ultimate capacity of concrete piles in clay soil.

For skin friction the relationship is as under.

$$f_s = 1.8\bar{N}_{60} \quad (\text{in kPa}) \leq 70 \text{ kPa} \quad (6.3.21)$$

For end bearing, the relationship is as under.

$$f_b = 45N_{60} \quad (\text{in kPa}) \leq 4000 \text{ kPa} \quad (6.3.22)$$

Where, \bar{N}_{60} is the average N-value over the pile shaft length and N_{60} is the N-value in the vicinity of pile tip. A factor of safety of 3.5 shall be used to estimate allowable capacity.

3.10.1.14 Axial capacity of driven precast pile in cohesionless soil using static bearing capacity equations

Piles in cohesionless soils shall be designed by effective stress methods of analysis for drained loading conditions. The ultimate axial capacity of piles in cohesionless soils may also be calculated using empirical effective stress method or from in-situ methods and analysis such as the cone penetration or pressure meter tests. Dynamic formula may be used for driven piles in cohesionless soils such as gravels, coarse sand and deposits where pore pressure developed due to driving is quickly dissipated. For piles in cohesionless soil, the ultimate side resistance may be estimated using the following formula:

$$f_s = \beta \sigma'_z \quad (6.3.23)$$

Where, σ'_z is the effective vertical stress at the level under consideration. The values for β are as under.

$$\begin{aligned} \beta &= 0.10 && \text{for } \phi = 33^\circ \\ \beta &= 0.20 && \text{for } \phi = 35^\circ \\ \beta &= 0.35 && \text{for } \phi = 37^\circ \end{aligned}$$

For uncemented calcareous sand the value of β varies from 0.05 to 0.10.

The following equation, as used for cohesive soil, may be used to compute the ultimate end bearing capacity of piles in sandy soil in which, the maximum effective stress, σ'_z allowed for the computation is 240 kPa. Figure 6.3.2 may also be used to estimate the value of N_q .

$$f_b = (\sigma'_v)_b (N_q)_b \quad (6.3.24)$$

$N_q = 8$ to 12	for loose sand
$N_q = 12$ to 40	for medium sand
$N_q = 40$	for dense sand

3.10.1.15 Critical depth for end bearing and skin friction

The vertical effective stress (σ'_v or σ'_z) increases with depth. Hence the skin friction should increase with depth indefinitely. In reality skin friction does not increase indefinitely. It is believed that skin friction would become a constant at a certain depth. This depth is named critical depth. Pile end bearing in sandy soils is also related to effective stress. Experimental data indicates that end bearing capacity does not also increase with depth indefinitely. Due to lack of a valid theory, Engineers use the same critical depth concept adopted for skin friction for end bearing capacity as well. Both the skin friction and the end bearing capacity are assumed to increase till the critical depth, D_c and then maintain a constant value. Following approximations may be used for the critical depth in relation to diameter of pile, D .

$D_c = 10D$	for loose sand
$D_c = 15D$	for medium dense sand
$D_c = 20D$	for dense sand

3.10.1.16 Axial Capacity of Driven Precast Pile in Cohesionless Soil using SPT Values

Standard Penetration Test N-value is a measure of relative density hence angle of internal friction of cohesionless soil. The skin friction of pile can thus be estimated from N-value. The following relation may be used for ultimate capacity of concrete piles in cohesionless soil and non-plastic silt.

For skin friction the relationship is as under.

For sand:

$$f_s = 2\bar{N}_{60} \quad (\text{in kPa}) \leq 60 \text{ kPa} \quad (6.3.25)$$

For non-plastic silt:

$$f_s = 1.7\bar{N}_{60} \quad (\text{in kPa}) \leq 60 \text{ kPa} \quad (6.3.26)$$

For end bearing, the relationship is as under.

For sand:

$$f_b = 40N_{60} \left(\frac{L}{D}\right) \quad (\text{in kPa}) \leq 400N_{60} \text{ and } \leq 11000 \text{ kPa} \quad (6.3.27)$$

For non-plastic silt:

$$f_b = 30N_{60} \left(\frac{L}{D}\right) \quad (\text{in kPa}) \leq 300N_{60} \text{ and } \leq 11000 \text{ kPa} \quad (6.3.28)$$

Where, \bar{N}_{60} is the average N-value over the pile shaft length and N_{60} is the N-value in the vicinity of pile tip. A higher factor of safety of 3.5 should be used to estimate allowable capacity.

3.10.1.17 Axial capacity of driven precast pile using pile load Test

Generally, the load on test pile to determine ultimate capacity is twice the design load. The test load on service/working pile is 1.5 times the design load. The following criteria should be met in deciding the allowable/safe pile capacity.

Safe Load for Single Pile

- (a) Two thirds of the final load at which the load displacement attains a value of 12 mm unless otherwise required in a given case on the basis of nature and type of structure in which case, the safe load should be corresponding to the stated total displacement permissible.
- (b) Fifty (50) percent of the final load at which the total displacement equals to 10 percent of pile diameter case of uniform diameter piles and 7.5 percent of bulb diameter in case of under-reamed piles.

Safe Load for Pile Group

- (a) Final load at which the load displacement attains a value of 25 mm unless otherwise required in a given case on the basis of nature and type of structure, and
- (b) Two thirds of the final load at which the total displacement attains a value of 40 mm.

3.10.1.18 Selection of factor of safety for driven precast pile

Driven pile in soil shall be designed for a minimum overall factor of safety of 2.0 against bearing capacity failure (end bearing, side resistance or combined) when the design is based on the results of a load test conducted at the site, with good quality control. Otherwise, it shall be designed for a minimum factor of safety 3.0. The minimum recommended overall factor of safety is based on an assumed normal level of field quality control during construction. If a normal level of field quality control cannot be assured, higher minimum factors of safety shall be used. The recommended values of overall factor of safety on ultimate axial load capacity based on specified construction control is given in Tables 6.3.10a and 6.3.10b.

Partial factor of safety may be used independently for skin friction and end bearing. The values of partial factor of safety may be taken as 1.5 and 3.0 respectively for skin friction and end bearing. The design/allowable load may be taken as the minimum of the values considering overall and partial factor of safety.

Table 6.3.10a: Factor of Safety for Deep Foundation for Downward and Upward Load

Structure	Design Life (yrs.)	Probability of Failure	Design Factor of Safety			
			Good Control	Normal Control	Poor Control	V. Poor Control
Monument	> 100	10^{-5}	2.30	3.00	3.50	4.00
Permanent	25 -100	10^{-4}	2.00	2.50	2.80	3.00
Temporary	< 25	10^{-3}	1.40	2.00	2.30	2.80

Table 6.3.10b: Guidelines for Investigation, Analysis and Construction Control

Item	Good Control	Normal Control	Poor Control	V. Poor Control
Proper Subsoil Investigation	Yes	Yes	Yes	Yes
Proper Review of Subsoil Report	Yes	Yes	Yes	Yes
Supervision by Competent Geotechnical/Foundation Engineer	Yes	Yes	Yes	No

Item	Good Control	Normal Control	Poor Control	V. Poor Control
Load Test Data	Yes	Yes	Yes	No
Qualification of Contractor	Yes	Yes	No	No
Proper Construction Equipment's	Yes	No	No	No
Maintaining Proper Construction Log	Yes	No	No	No

3.10.1.19 Group piles and group capacity of driven precast piles

All piles shall be braced to provide lateral stability in all directions. Three or more piles connected by a rigid cap shall be considered as being braced (stable), provided that the piles are located in a radial direction from the centroid of the group, not less than 60° apart circumferentially. A two pile group in a rigid cap shall be considered to be braced along the axis connecting the two piles. Piles supporting walls shall be driven alternately in lines at least 300 mm apart and located symmetrically under the centre of gravity of the wall load, unless effective measures are taken to cater for eccentricity and lateral forces, or the wall piles are adequately braced to provide lateral stability. Individual piles are considered stable if the pile tops are laterally braced in two directions by construction, such as a structural floor slab, grade beams, struts, or walls.

Group pile capacity of driven piles should be determined as the product of the group efficiency, number of piles in the group and the capacity of a single pile. In general, a group efficiency value of 1.0 should be used except for friction piles driven in cohesive soils. The minimum center-to-center pile spacing of 2.5B is recommended. The nominal dimensions and length of all the piles in a group should be similar.

3.10.1.20 Pile caps

Pile caps shall be of reinforced concrete. The soil immediately below the pile cap shall not be considered as carrying any vertical load. The tops of all piles shall be embedded not less than 75 mm into pile caps and the cap shall extend at least 100 mm beyond the edge of all piles. The tops of all piles shall be cut back to sound material before capping. The pile cap shall be rigid enough, so that the imposed load can be distributed on the piles in a group equitably. The cap shall generally be cast over a 75 mm thick levelling course of concrete. The clear cover for the main reinforcement in the cap slab under such condition shall not be less than 50 mm.

3.10.1.21 Lateral load capacity on driven precast piles

Lateral capacity of vertical single piles shall be the least of the values calculated on the basis of soil failure, structural capacity of the pile and deflection of the pile head. In the analysis, pile head conditions (fixed-head or free-head) should be considered. For estimating the depth of fixity, established method of analysis shall be used. The main reinforcement of pile foundation is usually governed by the lateral load capacity and vice versa. Deflection calculations require horizontal subgrade modulus of the surrounding soil. When considering lateral load on piles, the effect of other coexistent loads, including axial load on the pile, shall be taken into consideration for checking structural capacity of the shaft.

To determine lateral load capacity, lateral load tests shall be performed with at least two times the proposed design working load. Allowable lateral load capacity will be the least from the following criteria.

- (i) Half of the lateral load at which lateral movement of the pile head is 12 mm or lateral load corresponding to any other specified displacement as per performance requirements.
- (ii) Final load at which the total displacement corresponds to 5 mm or lateral load corresponding to any other specified displacement as per performance requirements.

All piles standing unbraced in air, water or soils not capable of providing lateral support shall be designed as columns in accordance with the provisions of this Code.

3.10.1.22 Vertical ground movement and negative skin friction in driven precast piles

The potential for external loading on a pile by vertical ground movements shall be considered as part of the design. Vertical ground movements may result in negative skin friction or downdrag loads due to settlement of compressible soils or may result in uplift loads due to heave of expansive soils. For design purposes, the full magnitude of maximum vertical ground movement shall be assumed.

Driven piles installed in compressible fill or soft soil subject to compression shall be designed against downward load due to downdrag. The potential for external loading on a pile by negative skin friction/downdrag due to settlement of compressible soil shall be considered as a part of the design load. Evaluation of negative skin friction

shall include a load-transfer method of analysis to determine the neutral point (i.e., point of zero relative displacement) and load distribution along shaft. Due to the possible time dependence associated with vertical ground movement, the analysis shall consider the effect of time on load transfer between the ground and shaft and the analysis shall be performed for the time period relating to the maximum axial load transfer to the pile. Negative skin friction loads may be reduced by application of bitumen or other viscous coatings to the pile surfaces. In estimating negative skin friction the following factors shall be considered :

- (i) Relative movement between soil and pile shaft.
- (ii) Relative movement between any underlying compressible soil and pile shaft.
- (iii) Elastic compression of the pile under the working load.
- (iv) The rate of consolidation of the compressible layer.
- (v) Negative skin friction is mobilized only when tendency for relative movement between pile shaft and surrounding soil exists.

3.10.1.23 Driven precast pile in expansive soils (upward movement)

Piles driven in swelling soils may be subjected to uplift forces in the zone of seasonal moisture change. Piles shall extend a sufficient distance into moisture-stable soils to provide adequate resistance to swelling uplift forces. In addition, sufficient clearance shall be provided between the ground surface and the underside of pile caps or grade beams to preclude the application of uplift loads at the pile cap. Uplift loads may be reduced by application of bitumen or other viscous coatings to the pile surface in the swelling zone.

3.10.1.24 Dynamic/Seismic Design of Driven Precast Pile

In case of submerged loose sands, vibration caused by earthquake may cause liquefaction or excessive total and differential settlements. This aspect of the problem shall be investigated and appropriate methods of improvements should be adopted to achieve suitable values of N. Alternatively, large diameter drilled pier foundation shall be provided and taken to depths well into the layers which are not likely to liquefy.

3.10.1.25 Protection against corrosion and abrasion in driven precast pile

Where conditions of exposure warrant a concrete encasement or other corrosion protections shall be used on steel piles and steel shells. Exposed steel piles or steel shells shall not be used in salt or brackish water, and only with caution in fresh water. Details are given in Sec 3.6.2.

3.10.1.26 Dynamic monitoring of driven precast pile

Dynamic monitoring may be specified for piles installed in difficult subsurface conditions such as soils with obstructions and boulders to evaluate compliance with structural pile capacity. Dynamic monitoring may also be considered for geotechnical capacity verification, where the size of the project or other limitations deters static load testing.

3.10.1.27 Maximum allowable driving stresses in driven precast pile

Maximum allowable driving stresses in pile material for top driven piles shall not exceed $0.9f_y$ (compression), $0.9f_y$ (tension) for steel piles, $0.85f'_c$ concrete (compression) and $0.7f_y$ steel reinforcement (tension) for concrete piles and $0.85f'_c - f_{pc}$ (compression) for prestressed concrete piles.

3.10.1.28 Effect of buoyancy in driven precast pile

The effects of hydrostatic pressure shall be considered in the design of driven piles, where used with foundation subjected to buoyancy forces.

3.10.1.29 Protection against Deterioration of Driven Precast Piles

(a) Steel Pile

A steel pile design shall consider that steel piles may be subject to corrosion, particularly in fill soils (low pH soils, acidic, pH value <5.5) and marine environments. In fact, extremely acid soils (below pH 4.5) and very strongly alkaline soils (above pH 9.1) have significantly high corrosion loss rates when compared to other soils. For structural elements, the Code considers a site to be corrosive if one or more of the following conditions exist for the representative soil and/or water samples taken at the site: Chloride concentration is 500 ppm or greater, sulfate concentration is 2000 ppm or greater, or the pH is less than 6. A field electric resistivity survey or resistivity testing and pH testing of soil and ground water samples should be used to evaluate the corrosion potential.

Methods of protecting steel piling in corrosive environments include use of protective coatings, cathodic protection, and increased steel area. The corrosion guidelines are provided in Tables 6.3.6a and 6.3.6b.

(b) Concrete Pile

A concrete pile foundation design shall consider that deterioration of concrete piles can occur due to sulfates in soil, ground water, or sea water; chlorides in soils and chemical wastes; acidic ground water and organic acids. Laboratory testing of soil and ground water samples for sulfates and pH is usually sufficient to assess pile deterioration potential. A full chemical analysis of soil and water samples is recommended when chemical wastes are suspected. Methods of protecting concrete piling include dense impermeable concrete, sulfate resisting Portland cement, minimum cover requirements for reinforcement and use of epoxies, resins, or other protective coatings.

(c) Timber Pile

A timber pile foundation (used for temporary structures) design shall consider that deterioration of timber piles can occur due to decay from wetting and drying cycles or from insects or marine borers. Methods of protecting timber piling include pressure treating with creosote or other wood preservers.

3.10.1.30 Pile spacing, clearance and embedment in driven precast pile

End bearing driven piles shall be proportioned such that the minimum center-to-center pile spacing shall exceed the greater of 750 mm or 2.5 pile diameters/widths. The distance from the side of any pile to the nearest edge of the pile cap shall not be less than 100 mm. The spacing of piles shall be that the average load on the supporting strata will not exceed the safe bearing value of those strata as determined by test boring or other established methods.

Piles deriving their capacity from frictional resistance shall be sufficiently apart to ensure that the zones of soil from which the piles derive their support do not overlap to such an extent that their bearing values are reduced. Generally, in such cases, the spacing shall not be less than 3.0 times the diameter of the shaft. The tops of piles shall project not less than 75 mm into concrete after all damaged pile material has been removed.

3.10.1.31 Structural capacity of driven precast pile section

The cross-section of driven piles shall be of sufficient size and pile material shall have the necessary structural strength to resist all handling stresses during driving or installation and the necessary strength to transmit the load imposed on them to the underlying and surrounding soil. Pile diameter/cross-section of a pile shaft at any level shall not be less than the designated nominal diameter/cross-section. The structural design of piles must consider each of the following loading conditions.

- (i) Handling loads are those imposed on the pile between the time it is fabricated and the time it is in the pile driver leads and ready to be driven. They are generated by cranes, forklifts, and other construction equipment.
- (ii) Driving loads are produced by the pile hammer during driving.
- (iii) Service loads are the design loads from the completed structures.

The maximum allowable stress on a pile shall not exceed $0.33f'_c$ for precast concrete piles and $33f'_c - f_{pc}$ for prestressed concrete piles and $0.25f_y$ for steel H-piles. The axial carrying capacity of a pile fully embedded in soil with undrained shear strength greater than 10 kN/m^2 shall not be limited by its strength as long column. For driven piles in weaker soils (undrained shear strength less than 10 kN/m^2), due consideration shall be given to determine whether the shaft behaves as a long column or not. If necessary, suitable reductions shall be made in its structural strength considering buckling. The effective length of a pile not secured against buckling by adequate bracing shall be governed by fixity conditions imposed on it by the structure it supports and by the nature of the soil in which it is installed.

Minimum Reinforcement in Driven Concrete Pile

The longitudinal and transverse steel provided in piles should enable the pile to :

- Withstand handling stresses
- Endure driving stresses
- Provide the necessary structural capacity

The maximum bending stress is produced while handling if the pile is pitched at the head. To prevent whipping during handling, length/diameter ratio of the pile should never exceed 50. Otherwise, segmental pile should be used. Considering all of these, the recommended area of main reinforcement for precast concrete piles, designed

mainly for vertical load with small lateral capacity, should not be less than the following percentages of the cross sectional area of the piles. In all cases, its adequacy for handling stresses shall be checked. The following reinforcement provisions may not be valid for laterally loaded piles or piles for uplift resistance.

- (i) Pile length < 30 times the least width : 1.00%
- (ii) Pile length 30 to 40 times the least width : 1.5%
- (iii) Pile length > 40 times the least width : 2%

The lateral reinforcement resists the driving stresses induced in the piles and should be in the form hoops or links of diameter not less than 6 mm. The volume of lateral reinforcement shall not be less than the following :

- (i) At each end of the pile for a distance of about three times the least width/diameter – not less than 0.4% of the gross volume of the pile.
- (ii) In the body of the pile – not less than 0.2% of the gross volume of the pile.
- (iii) The transition between closer spacing and the maximum should be gradual over a length of 3 times the least width/diameter.

Minimum Grades of Concrete

The minimum 28 days cylinder strength of concrete for driven piles is 21 MPa. Depending on driving stresses, the following grades of concrete should be used.

- (i) For hard driving (driving stress > 1000 kN/m²) – 28 MPa
- (ii) For easy driving (driving stress ≤ 1000 kN/m²) – 21 MPa

3.10.2 Driven Cast-in-Place Concrete Piles

Driven cast-in-place concrete piles shall be in general cast in metal shells driven into the soil that will remain permanently in place. However, other types of cast-in-place piles, plain or reinforced, cased or uncased, may be used if the soil conditions permit their use and if their design and method of placing are satisfactory.

3.10.2.1 Shape

Cast-in-place concrete piles may have a uniform cross-section or may be tapered over any portion.

3.10.2.2 Minimum area

The minimum area at the butt of the pile shall be 650 cm² and the minimum diameter at the tip of the pile shall be 200 mm.

3.10.2.3 General reinforcement requirements

Depending on the driving and installation conditions and the loading condition, the amount of reinforcement and its arrangement shall vary. Cast-in-place piles, carrying axial loads only, where the possibility of lateral forces being applied to the piles is insignificant, need not be reinforced where the soil provides adequate lateral support. Those portions of cast-in-place concrete piles that are not supported laterally shall be designed as reinforced concrete columns and the reinforcing steel shall extend 3000 mm below the plane where the soil provides adequate lateral restraint. Where the shell is smooth pipe and more than 3 mm in thickness, it may be considered as load carrying in the absence of corrosion. Where the shell is corrugated and is at least 2 mm in thickness, it may be considered as providing confinement in the absence of corrosion.

3.10.2.4 Reinforcement in superstructure

Sufficient reinforcement shall be provided at the junction of the pile with the superstructure to make a suitable connection. The embedment of the reinforcement into the cap shall be as specified for precast piles.

3.10.2.5 Shell requirements

The shell shall be of sufficient thickness and strength, so as to hold its original form and show no harmful distortion after it and adjacent shells had driven and the driving core, if any, has been withdrawn. The plans shall stipulate that alternative designs of the shell must be approved by the Engineer before driving is done.

3.10.2.6 Splices

Piles may be spliced provided the splice develops the full strength of the pile. Splices should be detailed on the contract plans. Any alternative method of splicing providing equal results may be considered for approval.

3.10.2.7 Reinforcement cover

The reinforcement shall be placed a clear distance of not less than 50 mm from the cased or uncased sides. When piles are in corrosive or marine environments, or when concrete is placed by the water or slurry displacement methods, the clear distance shall not be less than 75 mm for uncased piles and piles with shells not sufficiently corrosion resistant. Reinforcements shall extend to within 100 mm of the edge of the pile cap.

3.10.2.8 Installation

Steel cased piles shall have the steel shell mandrel driven their full length in contact with surrounding soil, left permanently in place and filled with concrete. No pile shall be driven within 4.5 times the average pile diameter of a pile filled with concrete less than 24 hours old. Concrete shall not be placed in steel shells within the heave range of driving.

3.10.2.9 Concreting

For bored or driven cast-in-situ piles, concrete shall be deposited in such a way as to preclude segregation. Concrete shall be deposited continuously until it is brought to the required level. The top surface shall be maintained as level as possible and the formation of seams shall be avoided.

For under-reamed piles, the slump of concrete shall range between 100 mm and 150 mm for concreting in water free holes. For large diameter holes concrete may be placed by tremie or by drop bottom bucket; for small diameter boreholes a tremie shall be utilized.

A slump of 125 mm to 200 mm shall be maintained for concreting by tremie. In case of tremie concreting for piles of smaller diameter and length up to 10 m, the minimum cement content shall be 350 kg/m³ of concrete. For larger diameter and/or deeper piles, the minimum cement content shall be 400 kg/m³ of concrete.

For concreting under water, the concrete shall contain at least 10 percent more cement than that required for the same mix placed in the dry. The amount of coarse aggregate shall be not less than one and a half times, nor more than two times, that of the fine aggregate. The materials shall be so proportioned as to produce a concrete having a slump of not less than 125 mm, nor more than 200 mm.

3.10.2.10 Structural integrity

Bored piles shall be installed in such a manner and sequence as to prevent distortion or damage to piles being installed or already in place, to the extent that such distortion or damage affects the structural integrity of pile.

3.10.3 Prestressed Concrete Piles

3.10.3.1 Shape and size

Prestressed concrete piles that are generally octagonal, square or circular shall be of approved size and shape. Concrete in prestressed piles shall have a minimum compressive strength (cylinder), f'_c of 35 MPa at 28 days. Prestressed concrete piles may be solid or hollow. For hollow piles, precautionary measures should be taken to prevent breakage due to internal water pressure during driving.

3.10.3.2 Reinforcement

Within the context of this Code, longitudinal prestressing is not considered as load-bearing reinforcement. Sufficient prestressing steel in the form of high-tensile wire, strand, or bar should be used so that the effective prestress after losses is sufficient to resist the handling, driving, and service-load stresses. Post-tensioned piles are cast with sufficient mild steel reinforcement to resist handling stresses before stressing. For pretensioned piles, the longitudinal prestressing steel should be enclosed in a steel spiral with the minimum wire size ranging from ACI 318 W3.5 (nominal area 0.035 in², nominal dia=0.211 inch) to W5 (nominal area 0.05 in², nominal dia=0.252 inch) depending on the pile size. The wire spiral should have a maximum 6 in. (150 mm) pitch with closer spacing at each end of the pile and several close turns at the tip and pile head. The close spacing should extend over at least twice the diameter or thickness of the pile, and the few turns near the ends are often at 1 in. (25 mm) spacing. Occasionally, prestressed piles are designed and constructed with conventional reinforcement in addition to the prestressing steel to increase the structural capacity and ductility of the pile. This reinforcement reduces the stresses in the concrete and should be taken into account.

For prestressed concrete piles, the effective prestress after all losses should not be less than 700 lb/in² (4.8 MPa). Significantly higher effective prestress values are commonly used and may be necessary to control driving stresses in some situations. Bending stresses shall be investigated for all conditions of handling, taking into account the weight of the pile plus 50 percent allowance for impact, with tensile stresses limited to $5\sqrt{f'_c}$.

3.10.3.3 Vertical and spiral reinforcement

The full length of vertical reinforcement shall be enclosed within spiral reinforcement. For piles up to 600 mm in diameter, spiral wire shall be No.5 (U.S. Steel Wire Gage). Spiral reinforcement at the ends of these piles shall have a pitch of 75 mm for approximately 16 turns.

In addition, the top 150 mm of pile shall have five turns of spiral winding at 25 mm pitch. For the remainder of the pile, the vertical steel shall be enclosed with spiral reinforcement with not more than 150 mm pitch. For piles having diameters greater than 600 mm. spiral wire shall be No.4 (U.S. Steel Wire Gauge). Spiral reinforcement at the end of these piles shall have a pitch of 50 mm for approximately 16 turns. In addition, the top 150 mm of pile shall have four turns of spiral winding at 38 mm pitch. For the remainder of the pile, the vertical steel shall be enclosed with spiral reinforcement with not more than 100 mm pitch. The reinforcement shall be placed at a clear distance from the face of the prestressed pile of not less than 50 mm.

3.10.3.4 Driving and handling stresses

A prestressed pile shall not be driven before the concrete has attained a compressive strength of at least 28 MPa, but not less than such strength sufficient to withstand handling and driving forces.

3.10.4 Bored Piles

In bored cast in place piles, the holes are first bored with a permanent or temporary casing or by using bentonite slurry to stabilize the sides of the bore. A prefabricated steel cage is then lowered into the hole and concreting is carried by tremie method.

3.10.4.1 Shape and size

Bored cast-in-situ concrete piles that are generally circular in section shall be of approved size and shape. Concrete in bored cast-in-situ concrete piles shall have a minimum compressive strength (cylinder), f_c' of 21 MPa at 28 days.

3.10.4.2 Dimension

All shafts should be sized in 50 mm increments with a minimum shaft diameter of 400 mm.

3.10.4.3 Ultimate geotechnical capacity of bored pile for axial load

The basic concept of ultimate bearing capacity and useful equations for axial load capacity are identical to that of driven pile as described in Art. 3.10.1.10.

3.10.4.4 Axial capacity of bored piles in cohesive soil using static bearing capacity equations

The ultimate axial capacity of bored piles in cohesive soil may be calculated from the same static formula as used for driven piles, given by Equations 6.3.14a, 6.3.14b and 6.3.15, using a total stress method for undrained loading conditions, or an effective stress method for drained loading conditions. The skin friction f_s may be taken as 2/3rd the value of driven piles and the end bearing f_b may be taken as 1/3rd of that of driven pile.

3.10.4.5 Axial capacity of bored piles in cohesive soil using SPT values

The following relations may be used for preliminary design of ultimate capacity of concrete bored piles in clay soils.

For skin friction the relationship is as under.

$$f_s = 1.2\bar{N}_{60} \quad (\text{in kPa}) \leq 70 \text{ kPa} \quad (6.3.29)$$

For end bearing, the relationship is as under.

$$f_b = 25N_{60} \quad (\text{in kPa}) \leq 4000 \text{ kPa} \quad (6.3.30)$$

Where, \bar{N}_{60} is the average N-value over the pile shaft length and N_{60} is the N-value in the vicinity of pile tip. A higher factor of safety of 3.5 should be used to estimate allowable capacity.

3.10.4.6 Axial capacity of bored piles in cohesionless soil using static bearing

The ultimate axial capacity of bored piles in cohesionless soil may be calculated from the same static formula as used for driven piles described in Sec 3.10.1.10. The skin friction f_s may be taken as 2/3rd the value of driven pile and the end bearing f_b may be taken as 1/3rd of driven pile.

Critical Depth for End Bearing and Skin Friction

Similar to driven piles, following approximations may be used for the critical depth in relation to pile diameter, D.

$$\begin{aligned} D_c &= 10D && \text{for loose sand} \\ D_c &= 15D && \text{for medium dense sand} \\ D_c &= 20D && \text{for dense sand} \end{aligned}$$

3.10.4.7 Axial capacity of bored piles in cohesionless soil using SPT values

The following relations may be used for preliminary design of ultimate capacity of concrete bored piles in sand and non-plastic silty soils.

For skin friction the relationship is as under :

For sand

$$f_s = 1.0\bar{N}_{60} \quad (\text{in kPa}) \leq 60 \text{ kPa} \quad (6.3.31)$$

For non-plastic silt:

$$f_s = 0.9\bar{N}_{60} \quad (\text{in kPa}) \leq 60 \text{ kPa} \quad (6.3.32)$$

For end bearing, the relationship is as under.

For sand

$$f_b = 15N_{60} \left(\frac{L}{D}\right) \quad (\text{in kPa}) \leq 150N_{60} \text{ and } \leq 4000 \text{ kPa} \quad (6.3.33)$$

For non-plastic silt:

$$f_b = 10N_{60} \left(\frac{L}{D}\right) \quad (\text{in kPa}) \leq 100N_{60} \text{ and } \leq 4000 \text{ kPa} \quad (6.3.34)$$

Where, \bar{N}_{60} is the average N-value over the pile shaft length and N_{60} is the N-value in the vicinity of pile tip (down to a depth of 3D). A higher factor of safety of 3.5 should be used to estimate allowable capacity.

3.10.4.8 Axial capacity of bored pile using pile load test

The procedures and principles of pile load test for ultimate capacity are similar to that of driven piles.

3.10.4.9 Structural capacity of bored concrete pile/drilled shaft

Minimum Reinforcement in Bored Concrete Pile

For piles loaded in compression alone, it is generally only necessary to reinforce the shaft to a depth of 2 m greater than the depth of temporary casing to prevent any tendency for concrete lifting when pulling the casing. Piles subject to tension or lateral forces and eccentric loading (possibly being out of position or out of plumb) do however require reinforcement suitable to cope with these forces. The following criteria for typical nominal reinforcement for piles in compression shall be considered. Table 6.3.11 may be used as guidelines. The restrictions that apply to the use of this Table have to be carefully considered in any particular application.

Table 6.3.11: Guidance on the Minimum Reinforcing Steel for Bored Cast-in-place Piles

Pile Diameter (mm)	Main Reinforcement		Lateral (Hoop) Reinforcement	
	Bar Size (mm)	No. of Bars	Bar Size (mm)	Pitch (mm)
400	16	6	8	200
450	16	6	8	200
500	16	8	8	250
600	16	8	8	250
750	16	10	10	300
900	16	10	10	300
1050	16	12	10	300
1200	16	12	10	300
1500	20	12	10	400
1800	20	12	10	400
2100	20	16	10	400
2400	25	16	12	500

Notes:

- (a) Yield strength of steel = 420 MN/m²
- (b) The above guidelines are for “build-ability” only: They are not appropriate Where:
 - (i) Piles are required to resist any applied tensile or bending forces- the reinforcement has to be designed for the specific loading conditions.
 - (ii) Piles are required to accommodate positional and verticality tolerances, or where they are constructed through very soft alluvial deposits ($c_u < 10$ kN/m²). Specific reinforcement design is then necessary.
- (c) Minimum depth of reinforcement is taken as 3 m below cutoff for simple bearing only. Any lateral loads or moments taken by the pile will require reinforcement to extend to some depth below the zone subjected to bending forces. This zone may be determined from a plot of the bending moment with depth. Furthermore the reinforcement would normally extend at least 1 m below the depth of any temporary casing.
- (d) Even with the appropriate reinforcement care will still be required to prevent damage to piles by construction activities especially during cutting-down or in the presence of site traffic.

The longitudinal reinforcement shall be of high yield steel bars (min $f_y = 420$ Mpa) and shall not be less than:

- 0.5% of A_c for $A_c \leq 0.5$ m²;
- 0.375% of A_c for 0.5 m² < $A_c \leq 1$ m²;
- 0.25% of A_c for $A_c > 1.0$ m²;

Where, A_c is the gross cross-sectional area of the pile. The minimum diameter for the longitudinal bars should not be less than 16 mm for large diameter (diameter ≥ 600 mm) piles. Piles should have at least 6 longitudinal bars.

The assembled reinforcement cage should be sufficiently strong to sustain lifting and lowering into the pile bore without permanent distortion or displacement of bars or in addition bars should not be so densely packed that concrete aggregate cannot pass freely between them. Hoop reinforcement (for shear) is not recommended closer than 100 mm centres. Minimum Concrete cover to the reinforcement periphery shall be 75 mm. This guidance is only applicable for piles with vertical load.

Minimum Grades of Concrete

The integrity of pile shaft is of paramount importance, and the concreting mixes and methods that have been evolved for bored piles are directed towards this as opposed to the high strength concrete necessary for precast piles or structural work above ground. This prerequisite has led to the adoption of highly workable mixes, and the “total collapse” mix for tremie piles has been mentioned. In order to ensure that the concrete flows between the reinforcing bars with ease, and into the interstices of the soil, a high slump, self-compacting mix is called for. A minimum cement content of 350 kg/m³ is generally employed under dry placement condition, increasing to 400 kg/m³ under submerged condition at slumps greater than 125 mm, with a corresponding increase in fine aggregate content to maintain the cohesion of the mix. The water cement ratio in all cases is recommended as 0.45. Three mixes as recommended are given in Table 6.3.12.

Table 6.3.12: Recommended Concrete Slumps for Cast-in-place Bored Piles

Mix	Slump (mm)	Conditions of use
A	125	Poured into water-free unlined bore. Widely spaced reinforcement leaving ample room for free movement of the concrete between bars

Mix	Slump (mm)	Conditions of use
B	150	Where reinforcement is not placed widely enough to give free movement of concrete between bars. Where cutoff level of concrete is within casing. Where pile diameter is < 600 mm.
C	200	Where concrete is to be placed by tremie under water or bentonite in slurry.

3.10.4.10 Selection of factor of safety for bored pile

Selection of factor of safety for axial capacity of bored pile is similar to that used for driven piles.

3.10.4.11 Group capacity of bored pile

The behavior of group bored piles is almost similar to that of driven piles. For the pile cap, lateral load capacity, vertical ground movement, negative skin friction, piles in expansive soil, dynamic and seismic design, corrosion protection, dynamic monitoring and buoyancy. Sec 3.10.1.18 should be consulted as they are similar for both driven and bored piles. However, Individual bored piles are considered stable if the pile tops are laterally braced in two directions by construction, such as a structural floor slab, grade beams, struts, or walls. Generally, the use of a single pile as foundation is not recommended unless the diameter is 600 mm or more.

3.10.5 Settlement of Driven and Bored Piles

The settlement of axially loaded piles and pile groups at the allowable loads shall be estimated. Elastic analysis, load transfer and/or finite element techniques may be used. The settlement of the pile or pile group shall not exceed the tolerable movement limits as recommended for shallow foundations (Table 6.3.7). When a pile is loaded, two things would happen involving settlement.

- The pile would settle into the soil
- The pile material would compress due to load

The settlement of a single pile can be broken down into three distinct parts.

- Settlement due to axial deformation, S_{ax}
- Settlement at the pile tip, S_{pt}
- Settlement due to skin friction, S_{sf}

$$S_{t(Single)} = S_{ax} + S_{pt} + S_{sf} \quad (6.3.35a)$$

Moreover, piles acting in a group could undergo long term consolidation settlement.

Settlement due to axial deformation of a single pile can be estimated as :

$$S_{ax} = \frac{(Q_p + aQ_s)L}{AE_p} \quad (6.3.35b)$$

Where, Q_p = Load transferred to the soil at tip level

Q_s = Total skin friction load

L = Length of the pile

A = Cross section area of the pile

E_p = Young's modulus of pile material

$a = 0.5$ for clay and silt soils

$= 0.67$ for sandy soil

Pile tip settlement, S_{pt} can be estimated as :

$$S_{pt} = \frac{C_p Q_p}{D q_o} \quad (6.3.35c)$$

Where, Q_p = Load transferred to the soil at tip level

D = Diameter of the pile

q_o = Ultimate end bearing capacity

C_p = Empirical coefficient as given in Table 6.3.13

Table 6.3.13: Typical Values of C_p for Settlement Calculation of Single Pile

Soil Type	Values of C_p	
	Driven Pile	Bored Pile
Dense Sand	0.02	0.09
Loose Sand	0.04	0.18
Stiff Clay	0.02	0.03
Soft Clay	0.03	0.06
Dense Silt	0.03	0.09
Loose Silt	0.05	0.12

Skin friction acting along the shaft would stress the surrounding soil. Skin friction acts upward direction along the pile. The force due to pile on surrounding soil would be in downward direction. When the pile is loaded, the pile would slightly move down. The pile would drag the surrounding soil with it. Hence, the pile settlement would occur due to skin friction as given by :

$$S_{sf} = \frac{C_s Q_s}{D q_o} \quad (6.3.36)$$

Where, C_s = Empirical coefficient = $\left(0.93 + 0.16 \frac{L}{D}\right) C_p$
 C_p = Empirical coefficient as given in Table 6.3.9
 Q_s = Total skin friction load
 D = Diameter of the pile
 q_o = Ultimate end bearing capacity

Short Term Pile Group Settlement

Short term or elastic pile group settlement can be estimated using the following relation.

$$S_g = S_{t(single)} \left(\frac{B}{D}\right)^{0.5} \quad (6.3.37)$$

Where,
 S_g = Settlement of the pile group
 $S_{t(single)}$ = Total settlement of a single pile
 B = Smallest dimension of the pile group
 D = Diameter of the pile

Interestingly, geometry of the group does not have much of an influence on the settlement. As such, Group Settlement Ratio, R_s of a pile group consisting of n number of piles can be approximated as follows :

$$R_s = \frac{S_g}{S_{t(single)}} = (n)^{0.5} \quad (6.3.38)$$

The settlement of the group can be estimated as the highest value as obtained from Equations 6.3.37 and 6.3.38.

Long Term Settlement for Pile Group

For pile groups, settlement due to consolidation is more important than for single piles. Consolidation settlement of pile group in clay soil is computed using the following simplified assumptions.

- The pile group is assumed to be a solid foundation with a depth $2/3^{\text{rd}}$ the length of the piles
- Effective stress at mid-point of the clay layer is used to compute settlement

If soil properties are available, the consolidation settlement (S) may be obtained from the following equation. The depth of significant stress increase (10%) or the depth of bed rock whichever is less should be taken for computation of settlement. Stress distribution may be considered as 2 vertical to 1 horizontal.

$$S = \frac{C_c H}{1+e_o} \log \frac{\sigma'_o + \sigma'_p}{\sigma'_o} \quad (6.3.39)$$

Where,

C_c = Compression index of soil

e_o = initial void ratio

H = Thickness of the clay layer

σ'_o = Initial effective stress at mid-point of the clay layer

σ'_p = Increase in effective stress at mid-point of the clay layer due to pile load.

In absence of soil properties the following empirical equations may be used to estimate the long term consolidation settlement of clay soils.

For clay:

$$S = \frac{H}{M} \text{Ln} \left(\frac{\sigma'_1}{\sigma'_o} \right)^j \quad (6.3.40)$$

For sand:

$$S = \frac{2H}{M} \left[\left(\frac{\sigma'_1}{\sigma'_r} \right)^j - \left(\frac{\sigma'_o}{\sigma'_r} \right)^j \right] \quad (6.3.41)$$

Where,

H = Thickness of the clay layer

σ'_o = Initial effective stress at mid-point of the clay layer

σ'_1 = New effective stress at mid-point of the clay layer after pile load.

σ'_r = Reference stress (100 kPa)

M = Dimensionless modulus number as obtained from Table 6.3.14

j = Stress exponent as obtained from Table 6.3.14.

Table 6.3.14: Settlement Parameters

Soil	Density	Modulus Number, M	Stress Exponent, j
Till	V. Dense to Dense	1000 - 300	1.0
Gravel	-	400 - 40	0.5
Sand	Dense	400 - 250	0.5
Sand	Medium Dense	250 - 150	0.5
Sand	Loose	150 - 100	0.5
Silt	Dense	200 - 80	0.5
Silt	Medium Dense	80 - 60	0.5
Silt	Loose	60 - 40	0.5
Silty Clay	Stiff	60 - 40	0.5
Silty Clay	Medium Stiff	20 - 10	0.5
Silty Clay	Soft	10 - 5	0.5
Marine Clay	Soft	20 - 5	0.0
Organic Clay	Soft	20 - 5	0.0
Peat	-	5 - 1	0.0

3.10.6 Drilled Shafts/ Drilled Piers

Large diameter (more than 600 mm) bored piles are sometimes classified as drilled shaft or drilled piers. They are usually provided with enlarged base called bell. The provisions of this article shall apply to the design of axially and laterally loaded drilled shafts/ drilled piers in soil or extending through soil to or into rock.

3.10.6.1 Application of drilled shaft

Drilled shafts may be considered when spread footings cannot be founded on suitable soil within a reasonable depth and when piles are not economically viable due to high loads or obstructions to driving. Drilled shafts may be used in lieu of spread footings as a protection against scour. Drilled shafts may also be considered to resist high lateral or uplift loads when deformation tolerances are small.

3.10.6.2 Materials for drilled shaft

Shafts shall be cast-in-place concrete and may include deformed bar steel reinforcement, structural steel sections, and/or permanent steel casing as required by design.

3.10.6.3 Embedment for Drilled Shaft

Shaft embedment shall be determined based on vertical and lateral load capacities of both the shaft and sub-surface materials.

3.10.6.4 Batter drilled shaft

The use of battered shafts to increase the lateral capacity of foundations is not recommended due to their difficulty of construction and high cost. Instead, consideration should first be given to increasing the shaft diameter to obtain the required lateral capacity.

3.10.6.5 Selection of soil properties for drilled shaft

Soil and rock properties defining the strength and compressibility characteristics of the foundation materials are required for drilled shaft design.

3.10.6.6 Geotechnical design of drilled shafts

Drilled shafts shall be designed to support the design loads with adequate bearing and structural capacity, and with tolerable settlements. The response of drilled shafts subjected to seismic and dynamic loads shall also be evaluated. Shaft design shall be based on working stress principles using maximum un-factored loads derived from calculations of dead and live loads from superstructures, substructures, earth (i.e., sloping ground), wind and traffic. Allowable axial and lateral loads may be determined by separate methods of analysis.

The design methods presented herein for determining axial load capacity assume drilled shafts of uniform cross section, with vertical alignment, concentric axial loading, and a relatively horizontal ground surface. The effects of an enlarged base, group action, and sloping ground are treated separately.

3.10.6.7 Bearing capacity equations for drilled shaft

The ultimate axial capacity Q_{ult} of drilled shafts shall be determined in accordance with the principles laid for bored piles.

Cohesive Soil

Skin friction resistance in cohesive soil may be determined using either the α -method or the β -method as described in the relevant section of driven piles. However, for clay soil, α -method has wide been used by the engineers. This method gives:

$$f_s = \alpha s_u \tag{6.3.42}$$

Where,

f_s = Skin friction

s_u = undrained shear strength of soil along the shaft

α = adhesion factor = 0.55 for undrained shear strength ≤ 190 kPa (4000 psf)

For higher values of s_u the value of α may be taken from Figure 6.3.3 as obtained from test data of previous investigators.

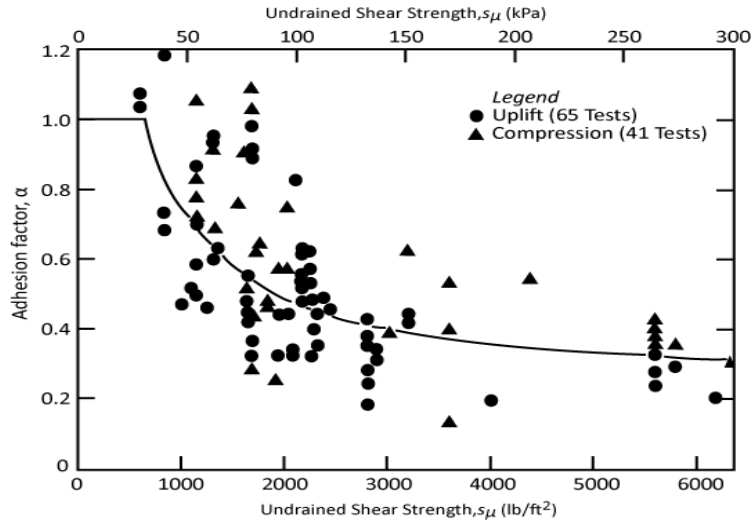


Figure 6.3.3 Adhesion factor α for drilled shaft (after Kulhawy and Jackson, 1989)

The skin friction resistance should be ignored in the upper 1.5 m of the shaft and along the bottom one diameter of straight shafts because of interaction with the end bearing. If end bearing is ignored for some reasons, the skin friction along the bottom one diameter may be considered. For belled shaft, skin friction along the surface of the bell and along the shaft for a distance of one shaft diameter above the top of bell should be ignored. For end bearing of cohesive soil, the following relations given by Equations 6.3.43 and 6.3.44 are recommended.

$$f_b = N_c S_u \leq 4000 \text{ kPa} \quad (6.3.43)$$

Where,
$$N_c = 6 \left[1 + 0.2 \left(\frac{L}{D_b} \right) \right] \leq 9$$

Where,

f_b = End bearing stress

S_u = undrained shear strength of soil along the shaft

N_c = Bearing capacity factor

L = Length of the pile (Depth to the bottom of the shaft)

D_b = Diameter of the shaft base

If the base diameter is more than 1900 mm, the value of f_b from Eq. 6.3.43 could produce settlements greater than 25 mm, which would be unacceptable for most buildings. To keep settlement within tolerable limits, the value of f_b should be reduced to f'_b by multiplying a factor F_r such that:

$$f'_b = F_r f_b \quad (6.3.44a)$$

$$F_r = \frac{2.5}{120 \omega_1 D_b / B_r + \omega_2} \leq 1.0 \quad (6.3.44b)$$

$$\omega_1 = 0.0071 + 0.0021 \left(\frac{L}{D_b} \right) \leq 0.0015 \quad (6.3.44c)$$

$$\omega_2 = 1.59 \sqrt{\frac{S_u}{\sigma_r}} \quad 0.5 \leq \omega_2 \leq 1.5 \quad (6.3.44d)$$

Where,

B_r = Reference width = 1 ft = 0.3 m = 12 inch = 300 mm

σ_r = Reference stress = 100 kPa = 2000 psf

Cohesionless Soil

Skin friction resistance in cohesionless soil is usually determined using the β -method. The relevant equation is reproduced again:

$$f_s = \beta \sigma'_z \tag{6.3.45}$$

$$\beta = K \tan \phi_s \tag{6.3.46}$$

Where,

f_s = Skin friction

σ'_z = Effective vertical stress at mid-point of soil layer

K = Coefficient of lateral earth pressure

ϕ_s = Soil shaft interface friction angle

The values of K and ϕ_s can be obtained from the chart of Tables 6.3.15, from the soil friction angle, ϕ and preconstruction coefficient of lateral earth pressure K_o . However, K_o is very difficult to determine. An alternative is to compute β directly using the following empirical relation.

$$\beta = 1.5 - 0.135 \sqrt{\frac{z}{B_r}} \tag{6.3.47}$$

Where,

B_r = Reference width = 1 ft = 0.3 m = 12 inch = 300 mm

z = Depth from the ground surface to the mid-point of the strata

Table 6.3.15: Typical ϕ_s/ϕ and K/K_o Values for the Design of Drilled Shaft

Construction Method	ϕ_s/ϕ	Construction Method	K/K_o
Open hole or temporary casing	1.0	Dry construction with minimal side wall disturbance and prompt concreting	1
Slurry method – minimal slurry cake	1.0	Slurry construction – good workmanship	1
Slurry method – heavy slurry cake	0.8	Slurry construction – poor workmanship	2/3
Permanent casing	0.7	Casing under water	5/6

The unit end bearing capacity for drilled shaft in cohesionless soils will be less than that for driven piles because of various reasons like soil disturbance during augering, temporary stress relief while the hole is open, larger diameter and depth of influence etc. The reasons are not well defined, as such the following empirical formula developed by Reese and O' Nell (1989) may be suggested to use to estimate end bearing stress.

$$f_b = 0.60\sigma_r N \leq 4500 \text{ kPa} \quad (6.3.48)$$

Where,

f_b = Unit bearing resistance

σ_r = Reference stress = 100 kPa = 2000 psf

N = Mean SPT value for the soil between the base of the shaft and a depth equal to two times the base diameter below the base. No overburden correction is required ($N = N_{60}$)

If the base diameter is more than 1200 mm, the value of f_b from Eq. 6.3.48 could produce settlements greater than 25 mm, which would be unacceptable for most buildings. To keep settlement within tolerable limits, the value of f_b should be reduced to f'_b by multiplying a factor F_r such that:

$$f'_b = F_r f_b \quad (6.3.49a)$$

$$F_r = 4.17 \frac{B_r}{D_b} \leq 1.0 \quad (6.3.49b)$$

Where,

B_r = Reference width = 1 ft = 0.3 m = 12 inch = 300 mm

D_b = Base diameter of drilled shaft

3.10.6.8 Other methods of evaluating axial load capacity of drilled shaft

A number of other methods are available to estimate the ultimate axial load capacity of drilled shafts. These methods are based on N-values obtained from Standard Penetration Test (SPT) and on angle of internal friction of sand. These methods may also be used to estimate the ultimate load carrying capacity of drilled shafts. Three of these methods are as follows and they are summarized in Appendix G.

- Method based on the Standard Penetration Test (CGS, 1985)
- Method based on Theory of Plasticity (CGS, 1985)
- Tomlinson (1995) Method

3.10.6.9 Factor of safety for drilled shaft

Similar to bored and driven piles, drilled shafts shall be designed for a minimum overall factor of safety of 2.0 against bearing capacity failure (end bearing, side resistance or combined) when the design is based on the results of a load test conducted at the site. Otherwise, it shall be designed for a minimum overall factor of safety 3.0. The minimum recommended overall factor of safety is based on an assumed normal level of field quality control during construction. If a normal level of field quality control cannot be assured, higher minimum factors of safety shall be used. The recommended values of overall factor of safety on ultimate axial load capacity based on specified construction control is presented in Tables 6.3.10a and 6.3.10b.

3.10.6.10 Deformation and settlement of axially loaded drilled shaft

Similar to driven and bored piles, settlement of axially loaded shafts at working or allowable loads shall be estimated using elastic or load transfer analysis methods. For most cases, elastic analysis will be applicable for design provided the stress levels in the shaft are moderate relative to Q_{ult} . Analytical methods are similar to that provided in Sec 3.10.1.10 for driven and bored piles. The charts provided in Appendix G may also be used to estimate the settlement of drilled shaft.

3.10.6.11 Drilled shaft in layered soil profile

The short-term settlement of shafts in a layered soil profile may be estimated by summing the proportional settlement components from layers of cohesive and cohesionless soil comprising the subsurface profile.

3.10.6.12 Tolerable movement of drilled shaft

Tolerable axial displacement criteria for drilled shaft foundations shall be developed by the structural designer consistent with the function and type of structure, fixity of bearings, anticipated service life, and consequences of unacceptable displacements on the structure performance. Drilled shaft displacement analyses shall be based on the results of in-situ/laboratory testing to characterize the load-deformation behavior of the foundation materials.

3.10.6.13 Group loading of drilled shaft

Cohesive Soil

Evaluation of group capacity of shafts in cohesive soil shall consider the presence and contact of a cap with the ground surface and the spacing between adjacent shafts.

For a shaft group with a cap in firm contact with the ground, Q_{ult} may be computed as the lesser of (1) the sum of the individual capacities of each shaft in the group or (2) the capacity of an equivalent pier defined in the perimeter area of the group. For the equivalent pier, the shear strength of soil shall not be reduced by any factor (e.g., α_1) to determine the Q_s component of Q_{ult} , the total base area of the equivalent pier shall be used to determine the Q_T component of Q_{ult} and the additional capacity of the cap shall be ignored. If the cap is not in firm contact with the ground, or if the soil at the surface is loose or soft, the individual capacity of each shaft should be reduced to ζ times Q_T for an isolated shaft, where $\zeta = 0.67$ for a center-to-center (CTC) spacing of $3B$ (where B is the shaft diameter) and $\zeta = 1.0$ for a CTC spacing of $6B$. For intermediate spacings, the value of ζ may be determined by linear interpolation. The group capacity may then be computed as the lesser of (1) the sum of the modified individual capacities of each shaft in group, or (2) the capacity of an equivalent pier as stated above.

Cohesionless Soil

Evaluation of group capacity of shafts in cohesion soil shall consider the spacing between adjacent shafts. Regardless of cap contact with the ground, the individual capacity of each shaft should be reduced to times Q_T for an isolated shaft, where $\zeta = 0.67$ for a center-to-center (CTC) spacing of $3B$ and $\zeta = 1.0$ for a CTC spacing of $8B$. For intermediate spacings, the value of ζ may be determined by linear interpolation. The group capacity may be computed as the lesser of (1) sum of the modified individual capacities of each shaft in the group or (2) capacity of an equivalent pier circumscribing the group including resistance over the entire perimeter and base areas.

3.10.6.14 Drilled shaft in strong soil overlying weak soil

If a group of shafts is embedded in a strong soil deposit which overlies a weaker deposit (cohesionless and cohesive soil), consideration shall be given to the potential for a punching failure of the tip into the weaker soil strata. For this case, the unit tip capacity q_E of the equivalent shaft may be determined using the following:

$$q_E = \frac{HB_T}{10} (q_{UP} - q_{Lo}) \leq q_{UP} \quad (6.3.50)$$

In the above equation q_{UP} is the ultimate unit capacity of an equivalent shaft bearing in the stronger upper layer and q_{Lo} is the ultimate unit capacity of an equivalent shaft bearing in the weaker underlying soil layer. If the underlying soil unit is a weaker cohesive soil strata, careful consideration shall be given to the potential for large settlements in the weaker layer.

3.10.6.15 Lateral loads on drilled shaft

Soil Layering

The design of laterally loaded drilled shafts in layered soils shall be based on evaluation of the soil parameters characteristic of the respective layers

Ground Water

The highest anticipated water level shall be used for design

Scour

The potential for loss of lateral capacity due to scour shall be considered in the design. If heavy scour is expected, consideration shall be given to designing the portion of the shaft that would be exposed as a column. In all cases, the shaft length shall be determined such that the design structural load can be safely supported entirely below the probable scour depth.

Group action

There is no reliable rational method for evaluating the group action for closely spaced, laterally loaded shafts. Therefore, as a general guide, drilled shaft with diameter B in a group may be considered to act individually when the center-to-center (CTC) spacing is greater than 2.5B in the direction normal to loading, and $CTC > 8B$ in the direction parallel to loading. For shaft layout not conforming to these criteria, the effects of shaft interaction shall be considered in the design. As a general guide, the effects of group action for in-line $CTC < 8B$ may be considered using the ratios (CGS, 1985) appearing as below, Table 6.3.16:

Table 6.3.16: Ratio of Group and Single Shaft Resistance

Centre to Centre Shaft Spacing for In-line Loading	Ratio of Lateral Resistance of Shaft in Group to Single Shaft
8B	1.00
6B	0.70
4B	0.40
3B	0.25

Cyclic Loading

The effects of traffic, wind, and other non-seismic cyclic loading on the load-deformation behavior of laterally loaded drilled shafts shall be considered during design. Analysis of drilled shafts subjected to cyclic loading may be considered in the COM624 analysis (Reese et. al., 1984).

Combined Axial and Lateral Loading

The effects of lateral loading in combination with axial loading shall be considered in the design. Analysis of drilled shafts subjected to combined loading may be considered in the COM624 analysis (Reese et. al., 1984).

Sloping Ground

For drilled shafts which extend through or below sloping ground. The potential for additional lateral loading shall be considered in the design. The general method of analysis developed by Borden and Gabr (1987) may be used for the analysis of shafts on unstable slopes. For shafts on marginally stable slopes. Additional consideration should be given for smaller factors of safety against slope failure or slopes showing ground creep, or when shafts extend through fills overlying soft foundation soils and bear into more competent underlying soil or rock formations. For unstable ground, detailed explorations, testing and analysis are required to evaluate potential additional lateral loads due to slope movements

Tolerable Lateral Movements

Tolerable lateral displacement criteria for drilled shaft foundations shall be developed by the structural designer consistent with the function and type of structure, fixity, anticipated service life, and consequences of unacceptable displacements on the structure performance. Drilled shaft lateral displacement analysis shall be based on the results of in-situ and/or laboratory testing to characterize the load-deformation behavior of the foundation materials.

3.10.6.16 Uplift loads on drilled shaft

Uplift capacity shall rely only on side resistance in conformance with related articles for driven piles. If the shaft has an enlarged base, Q_s shall be determined in conformance with related articles for driven piles.

3.10.6.17 Consideration of vertical ground movement

The potential for external loading on a shaft by vertical ground movement (i.e., negative skin friction down-drag due to settlement of compressible soil or uplift due to heave of expansive soil) shall be considered as a part of design. For design purposes, it shall be assumed that the full magnitude of maximum potential vertical ground movement occurs.

3.10.6.18 Negative skin friction

Evaluation of negative skin friction shall include a load-transfer method of analysis to determine the neutral point (i.e., point of zero relative displacement) and load distribution along shaft (e.g., Reese and O'Neill, 1988). Due to the possible time dependence associated with vertical ground movement, the analysis shall consider the effect of time on load transfer between the ground and shaft and the analysis shall be performed for the time period relating to the maximum axial load transfer to the shaft. Evaluation of negative skin friction shall include a load-transfer method of analysis to determine the neutral point (i.e., point of zero relative displacement) and load distribution along shaft (e.g., Reese and O'Neill, 1988). Due to the possible time dependence associated with vertical ground movement, the analysis shall consider the effect of time on load transfer between the ground and shaft and the analysis shall be performed for the time period relating to maximum axial load transfer to the shaft.

3.10.6.19 Expansive soils

Shafts designed for and constructed in expansive soil shall extend to a sufficient depth into moisture-stable soils to provide adequate anchorage to resist uplift movement in addition; sufficient clearance shall be provided between the ground surface and underside of caps or beams connecting shafts to preclude the application of uplift loads at the shaft/cap connection from swelling ground conditions.

3.10.6.20 Dynamic/seismic design of drilled shaft

Refer to Seismic Design section of this Code and Lam and Martin (1986a; 1986b) for guidance regarding the design of drilled shafts subjected to dynamic and seismic loads.

3.10.6.21 Structural shaft design, shaft dimensions and shaft spacing

Drilled shafts shall be designed to resist failure loads to insure that the shaft will not collapse or suffer loss of serviceability due to excessive stress and/or deformation.

Dimensions

All shafts should be sized in 50 mm increments with a minimum shaft diameter of 600 mm. The diameter of columns supported by shafts shall be less than or equal to the shaft diameter B.

Center to Center Spacing

The center-to-center spacing of drilled shafts of diameter B should be 3B or greater to avoid interference between adjacent shafts during construction. If closer spacing is required, the sequence of construction shall be specified and the interaction effects between adjacent shafts shall be evaluated by the designer.

Reinforcement

Where the potential for lateral loading is insignificant, drilled shafts need to be reinforced for axial loads only. Those portions of drilled shafts that are not supported laterally shall be designed as reinforced concrete columns in accordance with relevant sections in structural design part of the Code and the reinforcing steel shall extend a minimum of 5 m below the plane where the soil provides adequate lateral restraint. Where permanent steel casing is used and the shell is smooth pipe and more than 3 mm in thickness, it may be considered as load carrying in the absence of corrosion.

The design of longitudinal and spiral reinforcement shall be in conformance with the requirements of the relevant sections of the structural design part of the Code. Development length of deformed reinforcement shall be in conformance with the relevant sections of the structural design part of the Code.

Longitudinal Bar Spacing

The minimum clear distance between longitudinal reinforcement shall not be less than 3 times the bar diameter nor 3 times the maximum aggregate size. If bars are bundled in forming the reinforcing cage, the minimum clear distance between longitudinal reinforcement shall not be less than 3 times the diameter of the bundled bars. Where heavy reinforcement is required, consideration may be given to an inner and outer reinforcing cage.

Splices

Splices shall develop the full capacity of the bar in tension and compression. The location of splices shall be staggered around the perimeter of the reinforcing cage so as not to occur at the same horizontal plane. Splices may be developed by lapping, welding, and special approved connectors. Splices shall be in conformance with the relevant sections of the structural design part of the Code.

Transverse Reinforcement

Transverse reinforcement shall be designed to resist stresses caused by fresh concrete flowing from inside the cage to the side of the excavated hole. Transverse reinforcement may be constructed of hoops or spiral steel.

Handling Stresses

Reinforcement cages shall be designed to resist handling and placement stresses.

Reinforcement Cover

The reinforcement shall be placed a clear distance of not less than 50 mm from the permanently cased or 75 mm from the uncased sides. When shafts are constructed in corrosive or marine environments, or when concrete is placed by the water or slurry displacement methods, the clear distance shall not be less than 100 mm for uncased shafts and shafts with permanent casings not sufficiently corrosion resistant.

The reinforcement cage shall be centered in the hole using centering devices. All steel centering devices shall be epoxy coated.

Reinforcement into Superstructure

Sufficient reinforcement shall be provided at the junction of the shaft with the superstructure to make a suitable connection. The embedment of the reinforcement into the cap shall be in conformance with relevant articles of the structural design part of the Code.

3.10.6.22 Enlarged base of drilled shaft

Enlarged bases shall be designed to insure that plain concrete is not overstressed. The enlarged base shall slope at a side angle not less than 30 degrees from the vertical and have a bottom diameter not greater than 3 times diameter of the shaft. The thickness of the bottom edge of enlarged base shall not be less than 150 mm.

3.10.6.23 Construction of drilled shaft

Drilled shafts may be constructed using the dry, casing, or wet method of construction, or a combination of methods. In every case, excavation of hole, placement of concrete, and all other aspects of shaft construction shall be performed in conformance with the provisions of this Code.

The load capacity and deformation behavior of drilled shafts can be greatly affected by the quality and methods of construction. The effects of construction methods are incorporated in design by application of factor of safety consistent with the expected construction methods and level of field quality control measures undertaken as described in the relevant sections for driven piles.

Where the spacing between shafts in a group is restricted, consideration shall be given to the sequence of construction to minimize the effect of adjacent shaft construction operations on recently constructed shafts. The following construction procedure shall be followed:

- (i) Place permanent/temporary steel casing in position and embed casing toe into firm strata.
- (ii) Bore and excavate inside the steel casing down to casing toe level, or to a level approved, and continue excavation to final pile tip level using drilling mud. The fluid level inside casings shall at all times be at least 2 metres higher than outside the casings.
- (iii) Carefully clean up all mud or sedimentation from the bottom of borehole.
- (iv) Place reinforcement cage, inspection pipes etc.
- (v) Concrete continuously under water, or drilling fluid, by use of the tremie method.
- (vi) After hardening, break out the top section of the concrete pile to reach sound concrete.

In drilling of holes for all piles, bentonite and any other material shall be mixed thoroughly with clean water to make a suspension which shall maintain the stability of the pile excavation for the period necessary to place concrete and complete construction. The control tests shall cover the determination of density, viscosity, gel strength and pH values. Bentonite slurry shall meet the Specifications as shown in Table 6.3.17.

Table 6.3.17: Specifications of Bentonite Slurry

Item to be Measured	Range of Results at 20° C	Test Method
Density during drilling to support excavation	greater than 1.05 g/ml	Mud density Balance (ASTM D4380)
Density prior to concreting	less than 1.25 g/ml	Mud density Balance (ASTM D4380)
Viscosity	30 - 90 seconds	Marsh Cone Method (ASTM D6910)
pH	9.5 to 12	pH indicator paper strips or electrical pH meter (ASTM D4972)
Liquid limit	> 450%	Casagrande apparatus (ASTM D4318)

Temporary casing of approved quality or an approved alternative method shall be used to maintain the stability of pile excavations, which might otherwise collapse. Temporary casings shall be free from significant distortion.

Where a borehole is formed using drilling fluid for maintaining the stability of a boring, the level of the water or fluid in the excavation shall be maintained so that the water or fluid pressure always exceeds the pressure exerted by the soils and external ground water. The water or fluid level shall be maintained at a level not less than 2 m above the level of ground water.

The reinforcement shall be placed as indicated on the Drawings. Reinforcement in the form of a cage shall be assembled with additional support, such as Spreader forks and lacings, necessary to form a rigid cage. Hoops, links or helical reinforcement shall fit closely around the main longitudinal bars and be bound to them by approved wire, the ends of which shall be turned into the interior of the pile or pour. Reinforcement shall be placed and maintained in position. The cover to all reinforcement for pile cap and bored cast in place pile shall be not less than 75 mm.

Joints in longitudinal steel bars shall be permitted unless otherwise specified. Joints in reinforcement shall be such that the full strength of the bar is effective across the joint and shall be made so that there is no relative displacement of the reinforcement during the construction of the pile. Joints in longitudinal bars in piles with tension (for instance for test loading) shall be carried out by welding or other approved method.

Concrete to be placed under water or drilling fluid shall be placed by tremie equipment and shall not be discharged freely into the water or drilling fluid. The tremie equipment shall be designed to minimize the occurrence of entrapped air and other voids, so that it causes minimal surface disturbance, which is particularly important when a concrete-water interface exists. It shall be so designed that external projections are minimised, allowing the tremie to pass through reinforcing cages without causing damage. The internal face of the pipe of the tremie shall be free from projections. The tremie pipes shall meet the following requirements:

- (i) The tremie pipes shall be fabricated of heavy gage steel pipe to withstand all anticipated handling stress. Aluminium pipe shall not be used for placing concrete.
- (ii) Tremie pipes should have a diameter large enough to ensure that aggregates-caused blockage will not occur. The diameter of the tremie pipe shall be 200 mm to 300 mm.
- (iii) The tremie pipes shall be smooth internally.

- (iv) Since deep placement of concrete will be carried out, the tremie shall be made in sections/lengths with detachable joints that allow the upper sections/lengths to be removed as the placement progresses.
- (v) Sections may be joined by flanged, bolted connections (with gaskets) or may be screwed together. Whatever joint technique is selected, joints between tremie sections must be watertight. The joint system selected shall be tested for water tightness before beginning of concrete placement.
- (vi) The joint system to be used shall need approval of the Engineer.
- (vii) The tremie pipe should be marked to allow quick determination of the distance from the surface of the water to the mouth of the tremie.
- (viii) The tremie should be provided with adequately sized funnel or hopper to facilitate transfer of sufficient concrete from the delivery device to the tremie.

Before placing concrete, it shall be ensured that there is no accumulation of silt, other material, or heavily contaminated bentonite suspension at the base of the boring, which could impair the free flow of concrete from the pipe of the tremie. Flushing of boreholes before concreting with fresh drilling fluid/mud is preferred. A sample of the bentonite suspension shall be taken from the base of the boring using an approved sampling device. If the specific gravity of the suspension exceeds 1.25, the placing of concrete shall not proceed. In this event the Contractor shall modify the mud quality. During and after concreting, care shall be taken to avoid damage to the concrete from pumping and dewatering operations.

The hopper and pipe of the tremie shall be clean and watertight throughout. The pipe shall extend to the base of the boring and a sliding plug or barrier shall be placed in the pipe to prevent direct contact between the first charge of concrete in the pipe of the tremie and the water or drilling fluid. The pipe shall at all times penetrate the concrete, which has previously been placed and shall not be withdrawn from the concrete until completion of concreting. The bottom of the tremie pipe shall be embedded in the fresh concrete at least 2.0 m and maintained at that depth throughout concreting. At all times a sufficient quantity of concrete shall be maintained within the pipe to ensure that the pressure from it exceeds that from the water or drilling fluid.

To ensure the quality of concrete being free from mud, clay lumps or any other undesirable materials mixed with concrete at the top portion of the pile, fresh concrete shall be overflowed sufficiently at the end of the each pour. The level of concrete poured at the end of concreting operation shall be at least 600 mm higher than the elevation of the pile at cut-off.

3.10.6.24 Concreting of drilled shaft

In drilled shafts/cast-in-situ bored piles, concrete shall be placed only after excavation has been completed, inspected and accepted, and steel reinforcement accurately placed and adequately supported. Concrete shall be placed in one continuous operation in such a manner as to ensure the exclusion of any foreign matter and to secure a full sized shaft. Concrete shall not be placed through water except where tremie methods are approved. When depositing concrete from the top of the pile, the concrete shall not be chuted directly into the pile but shall be poured in a rapid and continuous operation through a funnel hopper centred at the top of the pile.

For large diameter holes concrete may be placed by tremie or by drop bottom bucket; for small diameter boreholes a tremie shall be utilized. In tremie concreting, toe of the tremie shall be set at a maximum of 150 mm above the bottom of the borehole. Maximum permissible siltation in bore hole prior to start of concrete operation shall be 75 mm. A slump of 125 mm to 150 mm shall be maintained for concreting by tremie. In case of tremie concreting for piles of smaller diameter and length up to 10 m, the minimum cement content shall be 350 kg/m³ of concrete. For larger diameter and/or deeper piles, the minimum cement content shall be 400 kg/m³ of concrete. See relevant sections of the Code for further specification.

For uncased concrete piles, if pile shafts are formed through unstable soil and concrete is placed in an open drill hole, a steel liner shall be inserted in the hole prior to placing concrete. If the steel liner is withdrawn during concreting, the level of concrete shall be maintained above the bottom of the liner to a sufficient height to offset any hydrostatic or lateral earth pressure.

If concrete is placed by pumping through a hollow stem auger, the auger shall not be permitted to rotate during withdrawal and shall be withdrawn in a steady continuous motion. Concrete pumping pressures shall be measured and shall be maintained high enough at all times to offset hydrostatic and lateral earth pressure. Concrete volumes shall be measured to ensure that the volume of concrete placed in each pile is equal to or greater than the theoretical volume of the hole created by the auger. If the installation process of any pile is interrupted or a loss of concreting pressure occurs, the hole shall be redrilled to original depth and reformed.

Augured cast-in-situ pile shall not be installed within 6 pile diameters centre to centre of a pile filled with concrete less than 24 hours old. If concrete level in any completed pile drops, the pile shall be rejected and replaced. Bored cast-in-situ concrete piles shall not be drilled/bored within a clear distance of 3 m from an adjacent pile with concrete less than 48 hours old. For under-reamed piles, the slump of concrete shall range between 100 mm and 150 mm for concreting in water free holes.

For concreting under water, the concrete shall contain at least 10 percent more cement than that required for the same mix placed in the dry. The amount of coarse aggregate shall be not less than one and a half times, nor more than two times, that of the fine aggregate. The materials shall be so proportioned as to produce a concrete having a slump of not less than 100 mm, nor more than 150 mm, except where plasticizing admixtures is used in which case, the slump may be 175 mm.

Successful placement of concrete under water requires preventing flow of water across or through the placement site. Once flow is controlled, the tremie placement consists of the following three basic steps:

- (i) The first concrete placed is physically separated from the water by using a “rabbit” or go-devil in the pipe, or by having the pipe mouth capped or sealed and the pipe dewatered.
- (ii) Once filled with concrete, the pipe is raised slightly to allow the “rabbit” to escape or to break the end seal. Concrete will then flow out and develop a mound around the mouth of the pipe. This is termed as “establishing a seal”.
- (iii) Once the seal is established, fresh concrete is injected into the mass of existing concrete.

Two methods are normally used for the placement of concrete using tremie pipe, namely, the capped tremie pipe approach and the “rabbit” plug approach. In the capped tremie approach the tremie pipe should have a seal, consisting of a bottom plate that seals the bottom of the pipe until the pipe reaches the bottom of excavation. The tremie pipe should be filled with enough concrete before being raised off the bottom. The tremie pipe should then be raised a maximum of 150 mm (6 inch) to initiate flow. The tremie pipe should not be lifted further until a mound is established around the mouth of the tremie pipe. Initial lifting of the tremie should be done slowly to minimize disturbance of material surrounding the mouth of the tremie.

In the “rabbit” plug approach, open tremie pipe should be set on the bottom, the “rabbit” plug inserted at the top and then concrete should be added to the tremie slowly to force the “rabbit” downward separating the concrete from the water. Once the tremie pipe is fully charged and the “rabbit” reaches the mouth of the tremie, the tremie pipe should be lifted a maximum of 150 mm (6 inch) off the bottom to allow the “rabbit” to escape and to start the concrete flowing. After this, a tremie pipe should not be lifted again until a sufficient mound is established around the mouth of the tremie.

Tremies should be embedded in the fresh concrete a minimum of 1.0 to 1.5 m (3 to 5 ft) and maintained at that depth throughout concreting to prevent entry of water into the pipe. Rapid raising or lowering of the tremie pipe should not be allowed. All vertical movements of the tremie pipe must be done slowly and carefully to prevent “loss of seal”. If “loss of seal” occurs in a tremie, placement of concrete through the tremie must be halted immediately. The tremie pipe must be removed and the end plate must be restarted using the capped tremie approach. In order to prevent washing of concrete in place, a “rabbit” plug approach must not be used to restart a tremie after “loss of seal”.

Means of raising or lowering tremie pipes and of removing pipes smoothly without loss of concrete and without disturbing placed concrete or trapping air in the concrete shall be provided. Pipes shall not be moved horizontally while they are embedded in placed concrete or while they have concrete within them.

Underwater concrete shall be placed continuously for the whole of a pour to its full depth approved by the Engineer, without interruption by meal breaks, change of shift, movements of placing positions, and the like. Delays in placement may allow the concrete to stiffen and resist flow once placement resumes. The rate of pour from individual tremie shall be arranged so that concrete does not rise locally to a level greater than 500 mm above the average level of the surrounding concrete.

Tremie blockages which occur during placement should be cleared extremely carefully to prevent loss of seal. If a blockage occurs, the tremie should be quickly raised 150 to 600 mm (6 inch to 2 ft) and then lowered in an attempt to dislodge the blockage. The depth of pipe embedment must be closely monitored during all such attempts. If the blockage cannot be cleared readily, the tremie shall be removed, cleared, resealed, and restarted.

The volume of concrete in place should be monitored throughout the placement. Underruns are indicative of loss of tremie seal since the washed and segregated aggregates will occupy a greater volume. Overruns are indicative of loss of concrete from the inside of the steel pile.

3.11 Field Tests for Driven Piles and Drilled Shafts

3.11.1 Integrity Test

Low strain integrity testing of piles is a tool for quality control of long structural elements that function in a manner similar to foundation piles, regardless of their method of installation, provided that they are receptive to low strain impact testing. The test provides velocity (and optionally force) data, which assists evaluation of pile integrity and pile physical dimensions (i.e., cross-sectional area, length), continuity and consistency of pile material. The test does not give any information regarding the pile bearing capacity or about pile reinforcement. Integrity test principles have been well documented in literature (ASTM 5882; Klingmuller, 1993). There exist two methods of integrity testing, namely, Pulse Echo Method (PEM) and Transient Response Method (TRM). In Pulse Echo Method, the pile head motion is measured as a function of time. The time domain record is then evaluated for pile integrity. In Transient Response Method, the pile head motion and force (measured with an instrumented hammer) are measured as a function of time. The data are then evaluated usually in the frequency domain.

In order to check the structural integrity of the piles Integrity tests shall be performed on the piles in accordance with the procedure outlined in ASTM D5882. The test is carried out by pressing a transducer onto a pile top while striking the pile head with a hand hammer. The Sonic Integrity Testing (SIT)-system registers the impact of the hammer followed by the response of the pile and shows the display. If instructed by the operator, the signal will be stored in the memory of the SIT-system together with other information, such as pile number, date, time, site, amplification factor, filter length etc. The reflectograms are horizontally scaled and vertically amplified to compensate external soil friction, which facilitate the interpretation. Consequently, the reflection of the pile toe matches the length of the pile which will be confirmed by the SIT-system. In case of any defects, the exact location can be determined from the graph on the display.

For any project where pile has been installed, integrity tests shall be performed on 100% of the piles. Integrity testing may not identify all imperfections, but it can be used in identifying major defects within effective length. In literature, there are many examples that highlight success of low strain integrity testing (Klingmuller, 1993).

Factors Influencing Implication of Pile Integrity Test

- (a) This sonic echo pile integrity testing or dynamic response method is based on measuring (or observing on an oscilloscope) the time it takes for a reflected compression stress wave to return to the top of the pile.
- (b) Some waves will be reflected by a discontinuity in the pile shaft. When the compressive strength is known for the pile material involved, the depth to the discontinuity and the pile length can be determined.
- (c) On the other hand, area of pile shaft and hence its diameter, is determined from impedance of wave response, while impedance in any section is a function of elastic modulus of pile material, shaft area and wave velocity propagating through that section. If the concrete material is uniform throughout the pile length, elastic modulus and the wave velocity (provided disturbance from other source of vibration nearby is insignificant) are constant for that pile. In that case, changes in impedance usually indicate changes of pile cross-sectional area.
- (d) While evaluating pile integrity (i.e., pile length and shaft diameter), the wave velocity is assumed to be constant throughout pile length. Thus, the reliability of integrity evaluation entirely depends on the pile material and its uniformity throughout shaft length while casting was done. The length and diameter obtained from pile integrity test is an indication of the actual length and diameter of the tested piles.
- (e) Besides, this test can only assess shaft integrity and gives no information for pile bearing capacity determination. However, if a large number of piles are tested, it is generally easy to focus the piles having unusual responses. Therefore, whenever an integrity testing is contemplated, consideration must be given to the limitations of the various methods/process of pile installation (i.e. pile driving or casting) and the possible need for further investigation (such as pile load test) to check the results of such testing.

- (f) It should be noted here that pile integrity test is an indicative test about the length and quality of concrete in the pile. This test does not give any idea about its actual load capacity. It is usually suggestive to substantiate the findings of integrity test by excavation or pull out of the pile to facilitate decisions about final acceptance or rejection of any pile. Because of the large cost involved in a pile load test, the necessity of integrity test in facilitating the selection of piles for load test is a rational approach for quality and safety assurance of piled foundations.

3.11.2 Axial Load Tests for Compression

Where accurate estimate of axial load carrying capacity of a pile is required tests in accordance with "Standard Test Method for Deep Foundations Under Static Axial Compressive Load", (ASTM D1143) or equivalent shall be performed on individual piles. For a major project, at least 2% of piles (test piles plus service piles) shall be tested in each area of uniform subsoil conditions. Where necessary, additional piles may be load tested to establish the safe design capacity. The ultimate load carrying capacity of a single pile may be determined with reasonable accuracy from load testing. The load test on a pile shall not be carried out earlier than 4 (four) weeks from the date of casting the pile. A minimum of one pile at each project shall be load tested for bored cast-in-situ piles.

Two principal types of test may be used for compression loading on piles - the constant rate of penetration (CRP) test and the maintained load (ML) test. The CRP test was developed by Whitaker (1963). The CRP method is essentially a test to determine the ultimate load on a pile and is therefore applied only to preliminary test piles or research type investigations where fundamental pile behaviour is being studied. In this test the compressive force is progressively increased to cause the pile to penetrate the soil at constant rate until failure occurs. The rate of penetration selected usually corresponds to that of shearing soil samples in unconfined compression tests. However, rate does not affect results significantly. In CRP test the recommended rates of penetration are 0.75 mm/min for friction piles in clay and 1.55 mm/min for piles end bearing in granular soil. The CRP test shall not be used for checking compliance with specification requirements for maximum settlement at given stages of loading.

Maintained load (ML) test is so far the most usual one in practice. In the ML test the load is increased in stages to 1.5 times or twice the working load with time settlement curve recorded at each stage of loading and unloading. The general procedure is to apply static loads in increments of 25% of the anticipated design load. The ML test may also be taken to failure by progressively increasing the load in stages. In the ML test, the load test arrangements as specified in (ASTM D1143) shall be followed. According to ASTM D1143 each load increment is maintained until the rate of settlement is not greater than 0.25 mm/hr or 2 hours is elapsed, whichever occurs first. After that the next load increment is applied. This procedure is followed for all increments of load. After the completion of loading if the test pile has not failed the total test load is removed any time after twelve hours if the butt settlement over one hour period is not greater than 0.25 mm otherwise the total test load is kept on the pile for 24 hours. After the required holding time, the test load is removed in decrement of 25% of the total test load with 1 hour between decrement. If failure occurs, jacking the pile is continued until the settlement equals 15% of the pile diameter or diagonal dimension. Selection of an appropriate load test method shall be based on an evaluation of the anticipated types and duration of loads during service, and shall include consideration of the following:

- (i) The immediate goals of the load test (i.e., to proof load the foundation and verify design capacity)
- (ii) The loads expected to act on the production foundation (compressive and/or uplift, dead and/or live), and the soil conditions predominant in the region of concern.
- (iii) The local practice or traditional method

As a minimum, the written test procedures should include the following:

- (i) Apparatus for applying loads including reaction system and loading system.
- (ii) Apparatus for measuring movements.
- (iii) Apparatus for measuring loads.
- (iv) Procedures for loading including rates of load application, load cycling and maximum load.
- (v) Procedures for measuring movements.
- (vi) Safety requirements.
- (vii) Data presentation requirements and methods of data analysis.
- (viii) Drawings showing the procedures and materials to be used to construct the load test apparatus.

3.11.2.1 Load test evaluation methods for axial compressive

A number of arbitrary or empirical methods are used to serve as criteria for determining the allowable and ultimate load carrying capacity from pile load test. Some are based on maximum permissible gross or net settlement as measured at the pile butt while the others are based on the performance of the pile during the progress of testing (Chellis, 1961; Whitaker, 1976; Poulos and Davis, 1980; Fuller, 1983). It is recommended to evaluate the load carrying capacity of piles and drilled shaft using any of the following methods along with the arbitrary methods:

- (a) Davission Offset Limit
- (b) British Standard Institution Criterion
- (c) Indian Standard Criteria
- (d) Butler-Hoy Criterion
- (e) Brinch-Hansen 90% Criterion
- (f) Other methods approved by the Geotechnical Engineer

The recommended criteria to be used for evaluating the ultimate and allowable load carrying capacity of piles and drilled shaft are summarized below.

- (a) A very useful method of computing the ultimate failure load has been reported by Davission (1973). This method is based on offset method that defines the failure load. The elastic shortening of the pile, considered as point bearing, free standing column, is computed and plotted on the load-settlement curve, with the elastic shortening line passing through the origin. The slope of the elastic shortening line is 20° . An offset line is drawn parallel to the elastic line. The offset is usually 0.15 inch plus a quake factor, which is a function of pile tip diameter. For normal size piles, this factor is usually taken as 0.1D inch, where D is the diameter of pile in foot. The intersection of offset line with gross load-settlement curve determines the arbitrary ultimate failure load. Davission method is too restrictive for drilled piles, unless the resistance is primarily friction. This method is recommended for driven precast piles.
- (b) Terzaghi (1942) reported that the ultimate load capacity of a pile may be considered as that load which causes a settlement equal to 10% of the pile diameter. However, this criterion is limited to a case where no definite

failure point or trend is indicated by the load-settlement curves. This criterion has been incorporated in BS 8004 "Code of Practice for Foundations" which recommends that the ultimate load capacity of pile should be that which causes the pile to settle a depth of 10% of pile width or diameter.

- (c) The allowable load capacity of pile should be 50% of the final load, which causes the pile to settle a depth of 10% of pile width or diameter (BS 8004).
- (d) Ultimate load capacity of pile is smaller of the following two (IS: 2911 Part-4):
 - (i) Load corresponding to a settlement equal to 10% of the pile diameter in the case of normal uniform diameter pile or 7.5% of base diameter in case of under-reamed or large diameter cast in-situ pile.
 - (ii) Load corresponding to a settlement of 12 mm.
- (e) Allowable load capacity of pile is smaller of the following (IS: 2911 Part-4):
 - (i) Two thirds of the final load at which the total settlement attains a value of 12 mm.
 - (ii) Half of the final load at which total settlement equal to 10% of the pile diameter in the case of normal uniform diameter pile or 7.5% of base diameter in case of under-reamed pile.
- (f) Butler and Hoy (1977) states that the intersection of tangent at initial straight portion of the load-settlement curve and the tangent at a slope point of 1.27 mm/ton determines the arbitrary ultimate failure load.
- (g) The Brinch Hansen (1963) proposed a definition for ultimate load capacity as that load for which the settlement is twice the settlement under 90 percent of the full test load.
- (h) Where failure occurs, the ultimate load may be taken to calculate the allowable load using a factor of safety of 2.0 to 2.5.

For load test on working pile/shaft, the safe load should be determined using the criteria of Sec 3.10.1.16.

3.11.2.2 Some factors influencing interpretations of load test results for axial compression

The following factors should be taken into account while interpreting the test results from pile load tests:

- (a) Potential residual loads (strains) in the pile which could influence the interpreted distribution of load along the pile shaft.
- (b) Possible interaction of friction loads from test pile with downward friction transferred to the soil from reaction piles obtaining part or all of their support in soil at levels above the tip level of the test pile.
- (c) Changes in pore water pressure in the soil caused by pile driving, construction fill and other construction operations which may influence the test results for frictional support in relatively impervious soils such as clay and silt.
- (d) Differences between conditions at time of testing and after final construction such as changes in grade groundwater level.
- (e) Potential loss of soil resistance from events such as excavation, or scour, or both of surrounding soil.
- (f) Possible difference in the performance of a pile in a group or of a pile group from that of a single pile.
- (g) Effect on long term pile performance of factors such as creep, environmental effects on pile material, friction loads from swelling soils and strength losses.
- (h) Type of structure to be supported, including sensitivity of structure to movement and relations between live and dead loads.
- (i) Special testing procedures which may be required for the application of certain acceptance criteria or methods of interpretation.
- (j) Requirement of all conditions for non-tested piles be basically identical to those for test pile including such thing as subsurface conditions, pile type, length, size and stiffness, and pile installation methods and equipment so that application or extrapolation of the test results to such other piles is valid.

3.11.3 Load Test for Uplift Capacity of Driven Pile, Bored Pile and Drilled Shaft

Where required by the design, the uplift capacity of pile and drilled shaft shall be determined by an approved method or analysis based on a minimum factor of safety of three or by load tests conducted in accordance with ASTM D3689 (Standard Test Method for Deep Foundations Under Static Axial Tensile Load). The maximum allowable uplift load shall not exceed the ultimate load capacity as determined using the results of load test conducted in accordance with ASTM D3689, divided by a factor of safety of 2.0. Where uplift is due to wind or seismic loading, the minimum factor of safety shall be 2.0 where capacity is determined by an analysis and 1.5 where capacity is determined by load tests.

For group pile subjected to uplift, the allowable working uplift load for the group shall be calculated by an approved method of analysis where the piles in the group are placed at centre-to-centre spacing of at least 2.5 times the least horizontal dimension of the largest pile, the allowable working uplift load for the group is permitted to be calculated as the lesser of the two:

- (i) The proposed individual working load times the number of piles in the group.
- (ii) Two-thirds of the effective weight of the group and the soil contained within a block defined by the perimeter of the group and the embedded length of the pile.
- (iii) One-half the effective weight of the pile group and the soil contained within a block defined by the perimeter of the group and the embedded pile length plus one-half the total soil shear on the peripheral surface of the group

Uplift or tension test on piles subject to tension/uplift shall be performed by a continuous rate of uplift (CRU) or an incremental loading (i.e. ML) test. Where uplift loads are intermittent or cyclic in character, as in wave loading on a marine structure, it is recommended to adopt repetitive loading on the test pile. The tests shall be performed in accordance with ASTM D3689. Safe load shall be taken as the least of the following:

- (a) Two thirds of the load at which the total displacement (pile top) is 12 mm or the load corresponding to a specified permissible uplift, and
- (b) Half of the load at which the load displacement curve shows a clear break (downward trend).

The initial load test (on test pile/shaft) shall be carried out up to twice the estimated design load or the load displacement curve shows a clear break. The routine test on working pile shall be done up to one and a half times the design load or 12 mm total displacement whichever occurred earlier.

3.11.4 Load Tests for Lateral Load Capacity

Load test for lateral capacity shall be performed as per the procedure of ASTM D3966. Safe load capacity shall be determined as per criteria mentioned in 3.10.1.20 for driven piles.

Division C: Additional Considerations in Planning, Design and Construction of Building Foundations (Sections 3.12 To 3.22)

3.12 Excavation

Excavation for building foundation or for other purpose shall be done in a safe manner so that no danger to life and property prevails at any stage of the work or after completion. The requirements of this Section shall be satisfied for all such works in addition to those of Sec 3.3 of Part 7.

Permanent excavations shall have retaining walls of sufficient strength made of steel, masonry, or reinforced concrete to retain the embankment, together with any surcharge load.

Excavations for any purpose shall not extend within 300 mm under any footing or foundation, unless such footing or foundation is properly underpinned or protected against settlement, beforehand.

The design and construction of deep excavation work more than 6 m depth or excavation in soft soil or erratic soil must be checked by a competent Geotechnical Engineer.

3.12.1 Notice to Adjoining Property

Prior to any excavation close to an adjoining building in another property, a written notice shall be given to the owner of the adjoining property at least 10 days ahead of the date of excavation. The person undertaking the excavation shall, where necessary, incorporate adequate provisions and precautionary measures to ensure safety of the adjoining property and shall supply the details of such measures in the notice to the owner of the adjoining property. He shall obtain approval of the

Authority regarding the protective provisions, and permission of the owner of the adjoining property regarding the proposed excavation in writing. The protective measures shall incorporate the following:

- (i) Where the level of the foundations of the adjoining structure is at or above the level of the bottom of the proposed excavation, the vertical load of the adjoining structure shall be supported by proper foundations, underpinning, or other equivalent means.
- (ii) Where the level of the foundations of the adjoining structure is below the level of the bottom of the proposed excavation, provision shall be made to support any increased vertical or lateral load on the existing adjoining structure caused by the new construction.

If on giving the required notice, incorporating or proposing to incorporate the protective provisions which have duly been approved by the Authority, the owner of the adjoining property refuses to permit the proposed excavation or to allow necessary access and other facilities to the person undertaking the excavation for providing the necessary and approved protection to the adjoining property, the responsibility for any damage to the adjoining property due to excavation shall be that of the owner of the adjoining property.

3.12.2 Excavation Work

Every excavation shall be provided with safe means of entry and exit kept available at all times. When an excavation has been completed, or partly completed and discontinued, abandoned or interrupted, or the required permits have expired, the lot shall be filled and graded to eliminate all steep slopes, holes, obstructions or similar sources of hazard. Fill material shall consist of clean, noncombustible substances. The final surface shall be graded in such a manner as to drain the lot, eliminate pockets, prevent accumulation of water, and preclude any threat of damage to the foundations on the premises or on the adjoining property.

3.12.2.1 Methods of protection

Shoring, Bracing and Sheeting

With the exception of rock cuts, the sides of all excavations, including related or resulting embankments, 1.5 m or greater in depth or height measured from the level of the adjacent ground surface to the deepest point of excavation, shall be protected and maintained by shoring, bracing and sheeting, sheet piling, or other retaining structures. Alternatively, excavated slopes may be inclined not steeper than 1:1, or

stepped so that the average slope is not steeper than forty five degrees with no step more than 1.5 m high, provided such slope does not endanger any structure, including subsurface structures. All sides or slopes of excavations or embankments shall be inspected after rainstorms, or any other hazard increasing event, and safe conditions shall be restored. Sheet piling and bracing needed in trench excavations shall have adequate strength to resist possible forces resulting from earth or surcharge pressure. Design of Protection system shall be checked by a qualified Geotechnical Engineer.

Guard Rail

A guard rail or a solid enclosure at least 1 m high shall be provided along the open sides of excavations, except that such guard rail or solid enclosure may be omitted from a side or sides when access to the adjoining area is precluded, or where side slopes are one vertical to three horizontal or flatter.

3.12.2.2 Placing of construction material

Excavated materials and superimposed loads such as equipment, trucks, etc. shall not be placed closer to the edge of the excavation than a distance equal to one and one-half times the depth of such excavation, unless the excavation is in rock or the sides have been sloped or sheet piled (or sheeted) and shored to withstand the lateral force imposed by such superimposed load. When sheet piling is used, it shall extend at least 150 mm above the natural level of the ground. In the case of open excavations with side slopes, the edge of excavation shall be taken as the toe of the slope.

3.12.2.3 Safety regulations

Whenever subsurface operations are conducted that may impose loads or movement on adjoining property, such as driving of piles, compaction of soils, or soil densification, the effects of such operations on adjoining property and structures shall be considered. The owner of the property that may be affected shall be given 48 hours written notice of the intention to perform such operations. Where construction operations will cause changes in the ground water level under adjacent buildings, the effects of such changes on the stability and settlement of the adjacent foundation shall be investigated and provision made to prevent damage to such buildings. When a potential hazard exists, elevations of the adjacent buildings shall be recorded at intervals of twenty four hours or less to ascertain if movement has occurred. If so, necessary remedial action shall be undertaken immediately.

Whenever, an excavation or fill is to be made that will affect safety, stability, or usability of, the adjoining properties or buildings shall be protected as required by the provisions of Sec 3.3 Part 7.

On excavation, the soil material directly underlying footings, piers, and walls shall be inspected by an engineer/architect prior to construction of the footing. If such inspection indicates that the soil conditions do not conform to those assumed for the purposes of design and described on the plans, or are unsatisfactory due to disturbance, then additional excavation, reduction in allowable bearing pressure, or other remedial measures shall be adopted.

Except in cases where a proposed excavation will extend less than 1.5 m below grade, all underpinning operations and the construction and excavation of temporary or permanent cofferdams, caissons, braced excavation surfaces, or other constructions or excavations required for or affecting the support of adjacent properties or buildings shall be subject to controlled inspection. The details of underpinning, and construction of cofferdams, caissons, bracing or other constructions required for the support of adjacent properties or buildings shall be shown on the plans or prepared in the form of shop or detail drawings and shall be approved by the engineer who prepared the plans.

3.13 Dewatering

All excavations shall be drained and the drainage maintained as long as the excavation continues or remains. Where necessary, pumping shall be used. No condition shall be created as a result of construction operations that will interfere with natural surface drainage. Water courses, drainage ditches, etc. shall not be obstructed by refuse, waste building materials, earth, stones, tree stumps, branches, or other debris that may interfere with surface drainage or cause the impoundment of surface water.

3.14 Slope Stability of Adjoining Buildings

The possibility of overturning and sliding of the building shall be considered. The minimum factor of safety against overturning of the structure as a whole shall be 1.5. Stability against overturning shall be provided by the dead load of the building, the allowable uplift capacity of piling, anchors, weight of the soil directly overlying footings provided that such soil cannot be excavated without recourse to major modification of the building, or by any combination of these factors.

The minimum factor of safety against sliding of the structure under lateral load shall be 1.5. Resistance to lateral loads shall be provided by friction between the foundation and the underlying soil, passive earth pressure, batter piles or by plumb piles, subject to the following:

- (i) The resistance to lateral loads due to passive earth pressure shall not be taken into consideration where the abutting soil could be removed inadvertently by excavation.
- (ii) In case of pile supported structures, frictional resistance between the foundation and the underlying soil shall be discounted.
- (iii) The available resistance to friction between the foundation and the underlying soil shall be predicted on an assumed friction factor of 0.5. A greater value of the coefficient of friction may be used subject to verification by analysis and test.

The faces of cut and fill slopes shall be prepared and maintained to control erosion. The control may consist of effective planting. The protection for slopes shall be installed as soon as practicable. Where cut slopes are not subject to erosion due to erosion resistant character of the materials, such protection may be omitted. Where necessary, check dams, cribbing, riprap or other devices or methods shall be employed to control erosion.

3.15 Fills

3.15.1 Quality of Fill

The excavation outside the foundation shall be backfilled with soil that is free of organic material, construction debris and large rocks. The backfill shall be placed in lifts and compacted in a manner which does not damage foundation, the waterproofing or damp-proofing material.

3.15.2 Placement of Fill

Fills to be used to support the foundation of any building or structure shall be placed in accordance with established engineering principle. Before placement of the fill, the existing ground surface shall be stripped off all organic growth, timber, rubbish and debris. After stripping, the ground surface shall be compacted. Materials for fill shall consist of sand, gravel, crushed stone, crushed earth, or a mixture of these. The fill material shall contain no particles exceeding 100 mm in the largest dimension. A soil investigation report and a report of satisfactory placement of fill, both acceptable

to the Building Official shall be submitted. In an uncontrolled fill, the soil within the building area shall be explored using test pits. At least one test pit penetrating at least 2 m below the level of the bottom of the proposed foundation shall be provided for every 200 m² of building area. Wherever such test pits consistently indicate that the fill is composed of material that is free of voids and free of extensive inclusion of mud, organic materials such as paper, garbage, cans, metallic objects, or debris, the fill material shall be acceptable. Where the fill shows voids or inclusions as described above, either the fill shall be treated as having no presumptive bearing capacity, or the building shall incorporate adequate strength and stiffness to bridge such voids or inclusions or shall be articulated to prevent damage due to differential or localized settlement of the fill.

3.15.3 Specifications

Where foundations are to be placed on controlled fill materials, the fill must be compacted in layers not exceeding 300 mm. Clear specifications shall be provided for the range of water content, the degree of compaction to be achieved and the method of compaction that shall be followed. Such specifications shall be based on the shear strength requirement for the fill soil and allowable settlement estimate. The minimum density of controlled fill shall be 95% of the optimum density obtained from "Standard Test Methods for Laboratory Compaction Characteristics of Soil Using Modified Effort", (ASTM D1557).

The degree of compaction achieved in a fill shall be obtained from in-situ density measurements. No new layer shall be placed unless a satisfactory density is attained in each layer.

3.16 Protective Retaining Structures for Foundations/ Shore Piles

A retaining wall is a wall designed to resist lateral earth and/or fluid pressures, including any surcharge, in accordance with accepted engineering practice. Retaining walls for foundations shall be designed to ensure stability against overturning, sliding, excessive foundation pressure and water uplift; and that they be designed for a safety factor of 1.5 against lateral sliding and overturning. Generally sheet pile retaining walls are used for construction raft foundations for buildings. Taller sheet piles may need a tie back anchor driven and anchored behind the soil of the sheet pile retaining wall.

3.17 Waterproofing and Damp-Proofing

3.17.1 General

Walls or portions thereof that retain earth and enclose interior spaces, and floors below grade shall be waterproofed and damp-proofed, with the exception of those spaces where such omission is not detrimental to the building or occupancy. The roof is also required to be waterproofed. The owner shall perform a subsurface investigation to determine the possibility of the ground water table rising above the proposed elevation of the floor or floors below grade unless satisfactory data from adjacent areas demonstrate that ground water has not been a problem.

There may arise two situations: (i) where no hydrostatic pressure occurs and (ii) where hydrostatic pressure occurs. Where hydrostatic pressure conditions exist, floors and walls below finished ground level shall be waterproofed in accordance with Sec 3.17.1.1 below. Where hydrostatic pressure conditions do not exist, damp-proofing and perimeter drainage shall be provided in accordance with Sec 3.17.1.2 below. In addition, the damp-proofing and waterproofing shall also meet the requirements of Sec 3.13.3. All damp-proofing and waterproofing materials shall conform to the requirements of Sec 2.16.7 of Part 5.

3.17.1.1 Waterproofing where hydrostatic pressure occurs

Where ground water investigation indicates that a hydrostatic pressure condition exists, or is likely to occur, walls and floors shall be waterproofed in accordance with the provisions stated as under.

3.17.1.2 Floor waterproofing

Floors required to be waterproofed shall be of concrete and shall be designed and constructed to withstand the anticipated hydrostatic pressure. Waterproofing of the floor shall be accomplished by placing under the slab a membrane of rubberized asphalt, or butyl rubber, or polymer modified asphalt, or neoprene, or not less than 0.15 mm polyvinyl chloride or polyethylene, or other approved materials, capable of bridging nonstructural cracks. Joints in the membrane shall be lapped not less than 150 mm and sealed in an approved manner.

3.17.1.3 Wall waterproofing

Walls required to be waterproofed shall be of concrete or masonry designed to withstand the anticipated hydrostatic pressure and other lateral loads. Prior to the application of waterproofing materials on concrete walls, all holes and recesses resulting from the removal of form ties shall be sealed with a bituminous material or other approved methods or materials. Unit masonry walls shall be pargeted on the exterior surface below ground level with not less than 10 mm of Portland cement mortar. The pargeting shall be continued to the foundation. Pargeting of unit masonry walls is not required where a material is approved for direct application to the masonry.

Waterproofing shall be applied from a point 300 mm above the maximum elevation of the ground water table down to the top of the spread portion of the foundation. The remainder of the wall up to a level not less than 150 mm above finished grade shall be damp-proofed.

Wall waterproofing materials shall consist of two-ply hot-mopped felts, not less than 0.15 mm polyvinylchloride, 1.0 mm polymer modified asphalt, 0.15 mm polyethylene or other approved methods or materials capable of bridging nonstructural cracks. Joints in the membrane shall be lapped not less than 150 mm and sealed in an approved manner. Joints in walls and floors, joints between the wall and the floor, and penetrations of the wall and floor shall be made watertight utilizing established methods and materials.

3.17.1.4 Damp-proofing with no hydrostatic pressure

Where hydrostatic pressure will not occur, floors and walls shall be damp-proofed and a subsoil drainage system shall be installed as described below:

3.17.1.5 Floor damp-proofing

For floors, damp-proofing materials shall be installed between the floor and base materials. The base material shall not be less than 100 mm in thickness consisting of gravel or crushed stone containing not more than 10 percent material that passes a 4.75 mm sieve. Where a site is located in well drained gravel or sand/gravel mixture, a floor base is not required. When the finished ground level is below the floor level for more than 25 percent of the perimeter of the building, the base material need not be provided. Where a separate floor is provided above a concrete slab the damp-proofing may be installed on top of the slab.

Damp-proofing materials, where installed beneath the slab, shall consist of not less than 0.15 mm polyethylene with joints lapped not less than 150 mm, or other approved methods or materials. Where permitted to be installed on top of the slab, damp-proofing shall consist of mopped on bitumen, not less than 0.1 mm polyethylene, or other approved methods or materials. Joints in membranes shall be lapped not less than 150 mm and sealed in an approved manner.

3.17.1.6 Wall damp-proofing

For walls, damp-proofing materials shall be installed and shall extend from a point 150 mm above grade, down to the top of the spread portion of the foundation.

Wall damp-proofing material shall consist of a bituminous material, acrylic modified cement base coating, rubberized asphalt, polymer-modified asphalt, butyl rubber, or other approved materials capable of bridging nonstructural cracks.

3.17.1.7 Perimeter drain

A drain shall be placed around the perimeter of a foundation that consists of gravel or crushed stone containing not more than 10 percent material that passes through a 4.76 mm sieve. The drain shall extend a minimum of 300 mm beyond the outside edge of the foundation. The thickness shall be such that the bottom of the drain is not higher than the bottom of the base under the floor, and that the top of the drain is not less than 150 mm above the top of the foundation. The top of the drain shall be covered with an approved filter membrane material. Where a drain tile or perforated pipe is used, the invert of the pipe or tile shall not be higher than the floor elevation. The top of joints or the top of perforations shall be protected with an approved filter membrane material. The pipe or tile shall be placed on not less than 50 mm of gravel or crushed stone complying with this section, and shall be covered with not less than 150 mm of the same material.

The floor base and foundation perimeter drain shall discharge by gravity or mechanical means into an approved drainage system. Where a site is located in well drained gravel or sand/gravel mixture, a dedicated drainage system is not required. When the finished ground level is below the floor level for more than 25 percent of the perimeter of the building, the foundation drain need be provided only around that portion of the building where the ground level is above the floor level.

3.17.2 Other Damp-proofing and Waterproofing Requirements**3.17.2.1 Placement of backfill**

The excavation outside the foundation shall be backfilled with soil that is free of organic material, construction debris and large rocks. The backfill shall be placed in lifts and compacted in a manner which does not damage the waterproofing or damp-proofing material or structurally damage the wall.

3.17.2.2 Site grading

The ground immediately adjacent to the foundation shall be sloped away from the building at a slope not less than 1 unit vertical in 12 units horizontal (1:12) for a minimum distance of 2.5 m measured perpendicular to the face of the wall or an alternative method of diverting water away from the foundation shall be used. Consideration shall be given to possible additional settlement of the backfill when establishing the final ground level adjacent to the foundation.

3.17.2.3 Erosion protection

Where water impacts the ground from the edge of the roof, down spout, scupper, valley or other rainwater collection or diversion device, provisions shall be used to prevent soil erosion and direct the water away from the foundation.

3.18 Foundation on Slopes

Where footings are to be founded on a slope, the distance of the sloping surface at the base level of the footing measured from the centre of the footing shall not be less than twice the width of the footing.

When adjacent footings are to be placed at different levels, the distance between the edges of footings shall be such as to prevent undesirable overlapping of structures in soil and disturbance of the soil under the higher footing due to excavation of the lower footing.

On a sloping site, footing shall be on a horizontal bearing and stepped. At all changes of levels, footings shall be lapped for a distance of at least equal to the thickness of foundation or three times the height of step, whichever is greater. Adequate precautions shall be taken to prevent tendency for the upper layers of soil to move downhill.

3.19 Foundations on Fills and Problematic Soils**3.19.1 Footings on Filled up Ground**

Footings shall not be constructed on loosely filled up ground with non-uniform density or consistency, unless adequate strengthening of the soil is made by applying ground improvement techniques.

3.19.2 Ground Improvement

In poor and weak subsoil, the design of shallow foundation for structures and equipment may present problems with respect to both sizing of foundation as well as control of foundation settlements. A viable alternative in certain situations developed over recent years is to improve the subsoil to an extent that the subsoil would develop an adequate bearing capacity and foundations constructed after subsoil improvement would have resultant settlements within acceptable limits. Selection of ground improvement techniques may be done in accordance with good practice.

3.19.3 Soil Reinforcement

Use of suitable geo-synthetics/geo-textiles may be made in an approved manner for ground improvement where applicable based on good practice.

3.20 Foundation Design for Dynamic Forces

3.20.1 Effect of Dynamic Forces

Where machinery operations or other vibrations are transmitted through foundation, consideration shall be given in the foundation design to prevent detrimental disturbance of the soil. Impact forces shall be neglected in foundation design except for foundations bearing on loose granular soils, foundations supporting cranes, heavy machinery and moving equipment, or where ratio of live load causing the impact to the dead load exceeds 50%.

3.20.2 Machine Foundation

Machine foundations are subjected to the dynamic forces caused by the machine. These dynamic forces are transmitted to the foundation supporting the machine. Although the moving parts of the machine are generally balanced, there is always some unbalance in practice which causes an eccentricity of rotating parts. This produces an oscillating force. The machine foundation must satisfy the criteria for dynamic loading in addition to that for static loading.

3.20.2.1 Types of machine foundations

Basically, there are three types of machine foundation:

- (i) Machines which produce a periodic unbalanced force, such as reciprocating engines and compressors. The speed of such machines is generally less than 600 rpm. In these machines, the rotary motion of the crank is converted into the translatory motion. The unbalanced force varies sinusoidal.

- (ii) Machines which produce impact loads, such as forge hammers and punch presses. In these machines, the dynamic force attains a peak value in a very short time and then dies out gradually. The response is a pulsating curve. It vanishes before the next pulse. The speed is usually between 60 to 150 blows per minute.
- (iii) High speed machines, such as turbines, and rotary compressors. The speed of such machines is very high; sometimes, it is even more than 3000 rpm.

The following four types of machine foundations are commonly used.

- (i) Block Type: This type of machine foundation consists of a pedestal resting on a footing (Figure 6.3.4a). The foundation has a large mass and a small natural frequency.
- (ii) Box Type: The foundation consists of a hollow concrete block (Figure 6.3.4b). The mass of the foundation is less than that in the block type and the natural frequency is increased.
- (iii) Wall Type: A wall type of foundation consists of a pair of walls having a top slab. The machine rests on the top slab (Fig6.3.4c).
- (iv) Framed Type: This type of foundation consists of vertical columns having a horizontal frame at their tops. The machine is supported on the frame (Figure 6.3.4d).

Machines which produce periodical and impulsive forces at low speeds are generally provided with a block type foundation. Framed type foundations are generally used for the machines working at high speeds and for those of the rotating types. Some machines which induce very little dynamic forces, such as lathes, need not be provided with a machine foundation. Such machines may be directly bolted to the floor.

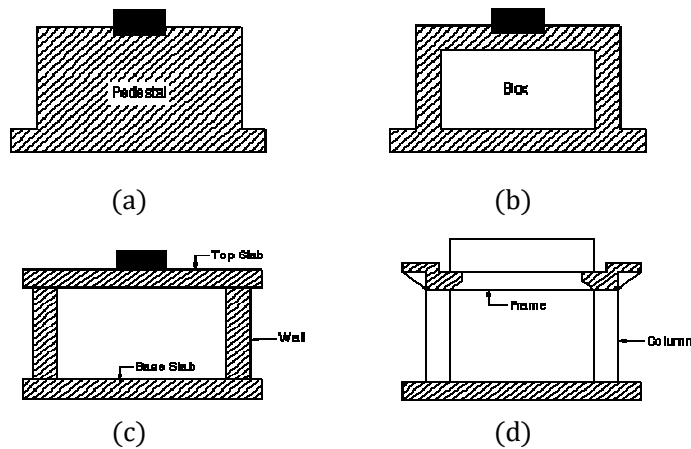


Figure 6.3.4. Types of machine foundations; (a) Block type; (b) Box type; (c) Wall type; (d) Framed type

3.20.2.2 Design considerations

For satisfactory performance, machine foundations should satisfy the following requirements: (i) resonance is avoided, (ii) bearing capacity and settlement are safe, and (iii) there is an adequate vibration and shock isolation. Avoidance of resonance is discussed in this Section.

Resonance:

Based on their operating frequencies, the machines are classified as (i) low speed having frequency less than 300 revolutions per minute (rpm), (ii) medium speed, frequency 300 to 1000 rpm, and (iii) high speed, frequency greater than 1000 rpm. To avoid resonance, the natural frequency (or the resonant frequency) of the machine foundation-soil system must be either very large or very small compared to the operating speed of the machine.

Low speed machines ($f_1 < 300$ rpm):

Provide a foundation with a natural frequency at least twice the operating frequency, i.e., the frequency ratio $r (= f_1/f_n)$ is less than 0.5. Natural frequency can be increased (i) by increasing base area or reducing total static weight of the foundation, (ii) by increasing modulus of shear rigidity of the soil by compaction, grouting or injection, (iii) by using piles to provide the required foundation stiffness.

High speed machines ($f_1 > 1000$ rpm):

Provide a foundation with natural frequency not higher than one-half of the operating value, i.e., frequency ratio ≥ 2 . Natural frequency can be decreased by increasing weight of foundation. During starting and stopping, the machine will operate briefly at resonant frequency f_r of the foundation. Probable amplitude is computed at both f_r and f_1 and compared with allowable values to determine if the foundation arrangement must be altered.

Types of foundations:

Considering their structural forms, the machine foundations, in general, are of the following types: (i) box foundation consisting of a pedestal of concrete, (ii) box foundation consisting of a hollow concrete block, (iii) wall foundation consisting of a pair of walls supporting the machine. (iv) framed foundation consisting of vertical columns and a top horizontal frame work which forms the seat of essential machinery.

Low speed machines (e.g., forge hammers, presses, low speed reciprocating engines and compressors) are generally supported on block foundation having a large contact area with soil.

Medium speed machines (e.g., reciprocating diesel and gas engines) also have, in general, block foundations resting on springs or suitable elastic pads.

High speed and rotating type of machines (e.g., internal combustion engines, electric motors, and turbo generator machines) are generally mounted on framed foundations. Other high speed machines are placed on block foundations.

As far as possible, the centre of gravity of the whole system and the centroid of the base area should be on the same vertical axis. At the most an eccentricity of 5% could be allowed.

Permissible amplitude:

Many times the permissible amplitude at operating speed is specified by the manufactures. If not specified, the following values may be adopted for guidance (i) low speed machines. ($f_1 < 500$ rpm), horizontal and vertical vibrations, $A = 0.25$ mm. (ii) operating speed $f_1 = 500$ to 1500 rpm, $A = 0.4$ mm to 0.6 mm for horizontal, and $A = 0.7$ mm to 0.9 mm for vertical mode of vibration; (iii) operating speed f_1 up to 3000 rpm, $A = 0.2$ mm for horizontal and $A = 0.5$ mm for vertical vibrations (iv) hammer foundations, $A = 10$ mm.

3.20.2.3 Design methods

The various design methods can be grouped as follows: (i) empirical and semi-empirical methods, (ii) methods considering soil as a spring and (iii) methods considering soil as a semi-infinite elastic mass (elastic half-space-approach) and its equivalent lumped parameter method. The lumped parameter method is currently preferred and will be described here. A good machine foundation should satisfy the following criteria.

- (i) Like ordinary foundations, it should be safe against shear failure caused by superimposed loads, and also the settlements should be within the safe limits.
- (ii) The soil pressure should normally not exceed 80% of the allowable pressure for static loading.
- (iii) There should be no possibility of resonance. The natural frequency of the foundation should be either greater than or smaller than the operating frequency of the machine.

- (iv) The amplitudes under service condition should be within the permissible limits for the machine.
- (v) The combined centre of gravity of the machine and the foundation should be on the vertical line passing through the centre of gravity of the base plane.
- (vi) Machine foundation should be taken to a level lower than the level of the foundation of the, adjacent buildings and should be properly separated.
- (vii) The vibrations induced should neither be annoying to the persons nor detrimental to other structures.
- (viii) Richart (1962) developed a plot for vertical vibrations, which is generally taken as a guide for various limits of frequency and amplitude which has been presented in Figure 6.3.5(a). A modified chart suggested by IS: 2974-Part 1, Figure 6.3.5(b) may also be used.
- (ix) The depth of the ground-water table should be at least one fourth of the width of the foundation below the base place.

3.20.2.4 Vibration analysis of a machine foundation:

Although a machine foundation has 6 degree of freedom, it is assumed to have a single degree of freedom for a simplified analysis. Figure 6.3.6 shows a machine foundation supported on a soil mass. In this case, the mass m_f lumps together the mass of the machine and the mass of foundation. The total mass m_f acts at the centre of gravity of the system. The mass is under the supporting action of the soil. The elastic action can be lumped together into a single elastic spring with a stiffness k . Likewise; all the resistance to motion is lumped into the damping coefficient c . Thus the machine foundation reduces to a single mass having one degree of freedom. The analysis of damped, forced vibration is, therefore, applicable to the machine foundation.

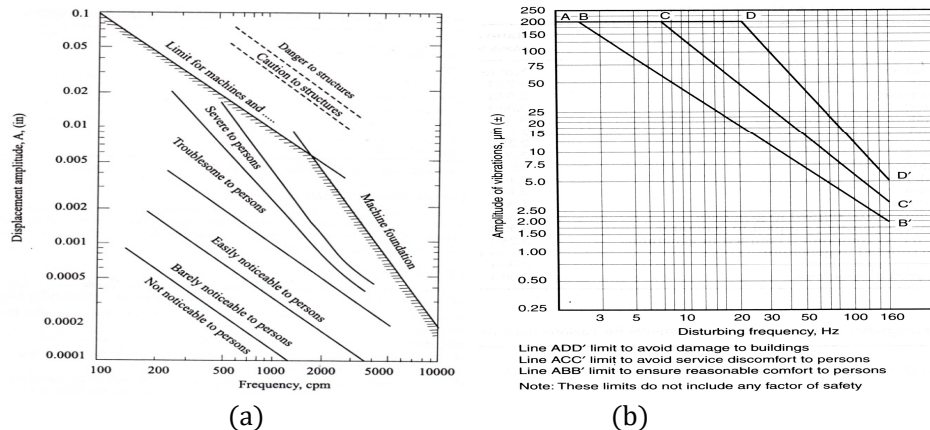


Figure 6.3.5. Limits of frequency and amplitudes of foundation; (a) Richart (1962) chart; (b) IS: 2974-Part 1, 1982

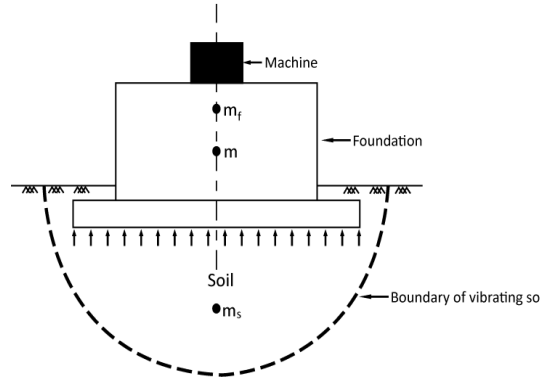


Figure 6.3.6. Machine foundation supported on a soil mass

3.20.2.5 Determination of parameters for vibration analysis

For vibration analysis of a machine foundation, the parameters m , c and k are required. These parameters can be determined as under.

Mass (m):

When a machine vibrates, some portion of the supporting soil mass also vibrates. The vibrating soil is known as the participating mass or in-phase soil mass. Therefore, the total mass of the system is equal to the mass of the foundation block and machine (m_f) and the mass (m_s) of the participating soil. Thus

$$m = m_f + m_s \quad (6.3.51)$$

Unfortunately, there is no rational method to determine the magnitude of m_s . It is usually related to the mass of the soil in the pressure bulb. The value of m_s generally varies between zero and m_f . In other words, the total mass (m) varies between m_f and $2m_f$ in most cases.

Spring Stiffness (k):

The spring stiffness depends upon the type of soil, embedment of the foundation block, the contact area and the contact pressure distribution. The following are the common methods.

Laboratory Test:

A triaxial test with vertical vibrations is conducted to determine Young's modulus (E). Alternatively, the modulus of rigidity (G) is determined conducting the test under torsional vibration, and E is obtained indirectly from the relation, $E = 2G(1 + \mu)$, where μ is Poisson's ratio. The stiffness (k) is determined as

$$k = \frac{A_{sp}E}{L} \quad (6.3.52)$$

Where, A_{sp} = cross-sectional area of the specimen, and L = length of the specimen.

Barkan's Method:

The stiffness can also be obtained from the value of E using the following relation given by Barken.

$$k = \frac{1.13E}{1-\mu} \sqrt{A} \quad (6.3.53)$$

Where, A = base area of the machine, i.e. area of contact.

Plate Load Test:

A repeated plate load test is conducted and the stiffness of the soil k_p is found as the slope of the load-deformation curve. The spring constant k of the foundation is as under.

For cohesive soils:

$$k = k_p \left(\frac{B}{B_p} \right) \quad (6.3.54)$$

For cohesionless soil:

$$k = k_p \left(\frac{B+0.3}{B_p+0.3} \right)^2 \quad (6.3.55)$$

Where, B is the width of foundation (in m), B_p is the width of plate (in m). Alternatively, spring constant can be obtained from the subgrade modulus k_s , as

$$k = k_s A \quad (6.3.56)$$

Where, A = area of foundation.

Resonance Test:

The resonance frequency f_n is obtained using a vibrator of mass m set up on a steel plate supported on the ground. The spring stiffness obtained from the relation

$$f_n = \frac{\omega_n}{2\pi} = \frac{1}{2\pi} \sqrt{k/m} = 4\pi^2 f_n m \quad (6.3.57)$$

Where, ω_n is natural circular frequency.

Damping Constant (c):

Damping is due to dissipation of vibration energy, which occurs mainly because of the following reasons.

- (i) Internal friction loss due to hysteresis and viscous effects.
- (ii) Radiational loss due to propagation of waves through soil.

The damping factor D for an under-damped system can be determined in the laboratory. Vibration response is plotted and the logarithmic decrement δ is found from the plot, as

$$\delta = \frac{2\pi D}{\sqrt{1-D^2}} \Rightarrow D = \frac{\delta}{2\pi} \quad (6.3.58)$$

The damping factor D may also be obtained from the area of hysteresis loop of the load displacement curve, as

$$D = \frac{\Delta W}{W} \quad (6.3.59)$$

Where, W = total work done; and ΔW = work lost hysteresis. The value of D for most soils generally varies between 0.01 and 0.1.

3.21 Geo-Hazard Analysis for Buildings

Geo-hazard analysis of buildings include design considerations for possible landslides, ground subsidence, earthquakes and other seismic events, erosion and scour, construction in toxic and/or contaminated landfills, groundwater contamination etc. A preliminary review of the selected site should be carried out for existence of any of the above mentioned geo-hazard in the area. A detailed analysis may be carried out only if the preliminary review indicates a significant threat for the building which may exist from any of the above mentioned potential geo-hazard at the selected location for the building. See relevant section for details.

3.22 List of Related Appendices

Appendix D	Methods of Soil Exploration, Sampling and Groundwater Measurements
Appendix E	Recommended Criteria for Identification and Classification of Expansive Soil
Appendix F	Construction of Pile Foundation
Appendix G	Other Methods of Estimating Ultimate Axial Capacity of Piles and Drilled Shafts, and Design Charts for Settlement
Appendix H	References of Chapter 3 Part 6 (Soils and Foundations).

PART VI
Chapter 4
Bamboo Structures

4.1 Scope

This Section relates to the use of bamboo in construction as structural elements, nonstructural elements and also for temporary works in structures or elements of the structure, ensuring quality and effectiveness of design and construction using bamboo. It covers minimum strength data, dimensional and grading requirements, seasoning, preservative treatment, design and jointing techniques with bamboo which would facilitate scientific application and long-term performance of structures. It also covers guidelines so as to ensure proper procurement, storage, precautions and design limitations on bamboo.

4.2 Terminology

For the purpose of this Section, the following definitions shall apply.

4.2.1 Anatomical Purpose Definitions

BAMBOO	Tall perennial grasses found in tropical and sub-tropical regions. They belong to the family Poaceae and sub-family Bambusoideae.
BAMBOO CULM	A single shoot of bamboo usually hollow except at nodes which are often swollen.
BAMBOO CLUMP	A cluster of bamboo culms emanating from two or more rhizomer in the same place.
CELLULOSE	A carbohydrate, forming the fundamental material of all plants and a main source of the mechanical properties of biological materials.
CELL	A fundamental structural unit of plant and animal life, consisting of cytoplasm and usually enclosing a central nucleus and being surrounded by a membrane (animal) or a rigid cell wall (plant).
CROSS WALL	A wall at the node closing the whole inside circumference and completely separating the hollow cavity below from that above.

HEMI CELLULOSE	The polysaccharides consisting of only 150 to 200 sugar molecules, also much less than the 10000 of cellulose.
LIGNIN	A polymer of phenyl propane units, in its simple form (C ₆ H ₅ CH ₃ CH ₂ CH ₃).
SLIVER	Thin strips of bamboo processed from bamboo culm.
TISSUE	Group of cells, which in higher plants consist of (a) Parenchyma - a soft cell of higher plants as found in stem pith or fruit pulp, (b) Epidermis - the outermost layer of cells covering the surface of a plant, when there are several layers of tissue.

4.2.2 Structural Purpose Definitions

BAMBOO MAT BOARD	A board made of two or more bamboo mats bonded with an adhesive.
BEAM	A structural member which supports load primarily by its internal resistance to bending.
BREAKING STRENGTH	A term loosely applied to a given structural member with respect to the ultimate load it can sustain under a given set of conditions.
BUNDLE-COLUMN	A column consisting of three or more number of culm bound as integrated unit with wire or strap type of fastenings.
CENTRE INTERNODE	A test specimen having its centre between two nodes.
CHARACTERISTIC LOAD	The value of loads which has a 95 percent probability of not exceeding during the life of the structure.
CHARACTERISTIC STRENGTH	The strength of the material below which not more than 5 percent of the test results are expected to fall.
CLEAVABILITY	The ease with which bamboo can be split along the longitudinal axis. The action of splitting is known as cleavage.
COLUMN	A structural member which supports axial load primarily by inducing compressive stress along the fibres.
COMMON RAFTER	A roof member which supports roof battens and roof coverings, such as boarding and sheeting.

CURVATURE	The deviation from the straightness of the culm.
DELAMINATION	Separation of mats through failure of glue.
END DISTANCE	The distance measured parallel to the fibres of the bamboo from the centre of the fastener to the closest end of the member.
FLATTEN BAMBOO	Bamboo consisting of culms that have been cut and unfolded till it is flat. The culm thus is finally spread open, the diaphragms (cross walls) at nodes removed and pressed flat.
FULL CULM	The naturally available circular section/shape.
FUNDAMENTAL OR ULTIMATE STRESS	The stress which is determined on a specified type/size of culms of bamboo, in accordance with standard practice and does not take into account the effects of naturally occurring characteristics and other factors.
INNER DIAMETER	Diameter of internal cavity of a hollow piece of bamboo.
INSIDE LOCATION	Position in buildings in which bamboo remains continuously dry or protected from weather.
JOINT	A connection between two or more bamboo structural elements.
JOIST	A beam directly supporting floor, ceiling or roof of a structure.
LENGTH OF INTERNODE	Distance between adjacent nodes.
LOADED END OR COMPRESSION END DISTANCE	The distance measured from the centre of the fastener to the end towards which the load induced by the fastener acts.
MATCHET	A light cutting and slashing tool in the form of a large knife.
MAT	A woven sheet made using thin slivers.
MORTISE AND TENON	A joint in which the reduced end (tenon) of one member fits into the corresponding slot (mortise) of the other.
NET SECTION	Section obtained by deducting from the gross cross-section (A), the projected areas of all materials removed by boring, grooving or other means.

NODE	The place in a bamboo culm where branches sprout and a diaphragm is inside the culm and the walls on both sides of node are thicker.
OUTER DIAMETER	Diameter of a cross-section of a piece of bamboo measured from two opposite points on the outer surface.
OUTSIDE LOCATION	Position in building in which bamboos are occasionally subjected to wetting and drying as in case of open sheds and outdoor exposed structures,
PERMISSIBLE STRESS	Stress obtained after applying factor of safety to the ultimate or basic stress.
PRINCIPAL RAFTER	A roof member which supports purlins.
PURLINS	A roof member directly supporting roof covering or common rafter and roof battens.
ROOF BATTENS	A roof member directly supporting tiles, corrugated sheets, slates or other roofing materials.
ROOF SKELETON	The skeleton consisting of bamboo truss or rafter over which solid bamboo purlins are laid and lashed to the rafter or top chord of a truss by means of galvanized iron wire, cane, grass, bamboo leaves, etc.
SLENDERNESS RATIO	The ratio of the length of member to the radius of gyration is known as slenderness ratio of member. (The length of the member is the equivalent length due to end conditions).
SPLITS	The pieces made from quarters by dividing the quarters radially and cutting longitudinally.
TAPER	The ratio of difference between minimum and maximum outer diameter to length.
UNLOADED END DISTANCE	The end distance opposite to the loaded end
WALL THICKNESS	Half the difference between outer diameter and inner diameter of the piece at any cross-section.
WET LOCATION	Position in buildings in which the bamboos are almost continuously damp, wet or in contact with earth or water, such as piles and bamboo foundations.

4.2.3 Definitions Relating to Defects

BAMBOO BORE/ GHOON HOLE	The defect caused by bamboo GHOON beetle (<i>Dinoderus</i> spp. <i>Bostychidae</i>), which attacks felled culms.
CROOKEDNESS	A localized deviation from the straightness in a piece of bamboo.
DISCOLORATION	A change from the normal colour of the bamboo which does not impair the strength of bamboo or bamboo composite products.

4.2.4 Definitions Relating to Drying Degradates

COLLAPSE	The defect occurring on account of excessive shrinkage, particularly in thick walled immature bamboo. When the bamboo wall shrinks, the outer layers containing a larger concentration of strong fibro-vascular bundles set the weaker interior portion embedded in parenchyma in tension, causing the latter to develop cracks. The interior crack develops into a wide split resulting in a depression on the outer surface. This defect also reduces the structural strength of round bamboo.
END SPLITTING	A split at the end of a bamboo. This is not so common a defect as drying occurs both from outer and interior wall surfaces of bamboo as well as the end at the open ends.
SURFACE CRACKING	Fine surface cracks not detrimental to strength, However, the cracking which occurs at the nodes reduces the structural strength.
WRINKLED AND DEFORMED SURFACE	Deformation in cross-section, during drying, which occurs in immature round bamboos of most species; in thick walled pieces, besides this deformation the outer surface becomes uneven and wrinkled. Very often the interior wall develops a crack below these wrinkles, running parallel to the axis.

4.3 Symbols

For the purpose of this Section, the following letter symbols shall have the meaning indicated against each, unless otherwise stated:

A = Cross-sectional area of bamboo (perpendicular to the direction of the principal fibres and vessels), $= \frac{\pi}{4}(D^2 - d^2)$, mm²

D = Outer diameter, mm

d = Inner diameter, mm

E = Modulus of elasticity in bending, N/mm²

f_c = Calculated stress in axial compression, N/mm²

f_{cp} = Permissible stress in compression along the fibres, N/mm²

I = Moment of inertia $= \frac{\pi}{64}(D^2 - d^2)$, mm⁴

l = Unsupported length of column, m or mm

M = Moisture content, %

r = Radius of gyration $= \sqrt{(I/A)}$, mm

R' = Modulus of rupture, N/mm²

W = Wall thickness, mm

Z = Section modulus, mm³

δ = Deflection or deformation, mm.

4.4 Materials

4.4.1 Species of Bamboo

In Bangladesh, four species are widely used, hence studied for the mechanical properties as tabulated in Table 6.4.1-6.4.4 for top, bottom and middle positions. Table 6.4.5 further summarize the average mechanical properties of 21 bamboo species.

Table 6.4.1: Moisture content and specific gravity values of bamboo species

Species	Moisture content (%)			Specific Gravity (based on oven dry weight and at different volumes)					
	bottom	middle	top	Green volumes			Oven dry volumes		
				bottom	middle	top	bottom	middle	top
Kali (<i>Oxytenanthera nigrociliata</i>)	129	118	104	0.48	0.49	0.51	0.66	0.69	0.74
Mitinga (<i>Bambusa tulda</i>)	108	92	86	0.54	0.58	0.61	0.75	0.79	0.83
Bethua (<i>Bambusa polymorpha</i>)	104	93	79	0.55	0.57	0.61	0.79	0.81	0.54
Borak (<i>Bambusa balcooa</i>)	100	84	66	0.57	0.64	0.74	0.79	0.84	0.85

Table 6.4.2: Shrinkages of wall thickness and diameter of bamboo species

Species	Shrinkage in wall thickness (%)						Shrinkage in diameter (%)		
	From green to 12% mc			From green to oven dry condition			From green to 12% mc		
	bottom	middle	top	bottom	middle	top	bottom	middle	top
Kali (<i>Oxytenanthera nigrociliata</i>)	9.6	8.1	5.9	13.2	10.7	8.7	4.8	3.0	2.4
Mitinga (<i>Bambusa tulda</i>)	11.9	7.3	4.9	14.9	9.6	7.6	3.9	3.5	2.6
Bethua (<i>Bambusa polymorpha</i>)	10.7	6.5	5.1	12.1	10.1	8.2	7.3	5.5	4.1
Borak (<i>Bambusa balcooa</i>)	11.1	7.6	4.8	13.7	11.1	8.4	4.2	3.4	2.5

Table 6.4.3: Compressive strength of bamboo species

Species	Compression parallel to the grain (kg/cm ²)					
	Green			Air dry		
	bottom	middle	top	bottom	middle	top
Kali (<i>Oxytenanthera nigrociliata</i>)	257	287	301	346	387	417
Mitinga (<i>Bambusa tulda</i>)	403	466	513	529	596	620
Bethua (<i>Bambusa polymorpha</i>)	320	361	419	452	512	534
Borak (<i>Bambusa balcooa</i>)	394	459	506	510	536	573

Table 6.4.4: Modulus of elasticity and modulus of rupture values of bamboo species

Species	Modulus of elasticity (1000 kg/cm ²)						Modulus of rupture (kg/cm ²)					
	Green			Air dry			Green			Air dry		
	bottom	middle	top	bottom	middle	top	bottom	middle	top	bottom	middle	top
Kali (Oxytenanthera nigrociliata)	119	131	169	131	150	224	541	459	415	721	580	530
Mitinga (Bambusa tulda)	105	138	147	114	140	168	710	595	542	883	745	671
Bethua (Bambusa polymorpha)	61	65	82	60	70	96	469	426	373	566	468	414
Borak (Bambusa balcooa)	72	92	103	93	108	127	850	712	624	926	787	696

4.4.2 Grouping

Sixteen species of bamboo are suitable for structural applications and classified into three groups, namely, Group A, Group B and Group C as given in Table 6.4.6.

The characteristics of these groups are as given in Table 6.4.6.

Species of bamboo other than those listed in the Table 6.4.6 may be used, provided the basic strength characteristics are determined and found more than the limits mentioned therein. However, in the absence of testing facilities and compulsion for use of other species, and for expedient designing, allowable stresses may be arrived at by multiplying density with factors as given in Table 6.4.5.

4.4.3 Moisture Content in Bamboo

With decrease of moisture content (M) the strength of bamboo increases exponentially and bamboo has an intersection point (fibre saturation point) at around 25 percent moisture content depending upon the species. Matured culms shall be seasoned to about 20 percent moisture content before use.

Table 6.4.5: Physical and Mechanical Properties of Bamboos (in Round Form)

Species	Properties						
	In Green Condition				In Air Dry Conditions		
	Density kg/m ³	Modulus of Rupture N/mm ²	Modulus of Elasticity 10 ³ N/mm ²	Maximum Compressive strength N/mm ²	Density kg/m ³	Modulus of Rupture N/mm ²	Modulus of Elasticity 10 ³ N/mm ²
<i>Bambusa auriculata</i>	594	65.1	15.01	36.7	670	89.1	21.41
<i>B. balcooa</i>	740	64.2	7.06	38.6	850	68.3	9.12
<i>B. bambos</i> (Syn. <i>B. atwindinacea</i>)	559	58.3	5.95	35.3	663	80.1	8.96
<i>B. bumanica</i>	570	59.7	11.01	39.9	672	105.0	17.81
<i>B. glancescens</i> (Syn. <i>B. nana</i>)	691	82.8	14.77	53.9	—	—	—
<i>B. nutans</i>	603	52.9	6.62	45.6	673	52.4	10.72
<i>B. pallida</i>	731	55.2	12.90	54.0	—	—	—
<i>B. polymorpha</i>	610	36.6	6.0	31.4	840	40.6	5.89
<i>B. tulda</i>	610	53.2	10.3	39.5	830	65.8	11.18
<i>B. ventricosa</i>	626	34.1	3.38	36.1	—	—	—
<i>B. vulgaris</i>	626	41.5	2.87	38.6	—	—	—
<i>Cephalostachyum</i> <i>pergracile</i>	601	52.6	11.16	36.7	640	71.3	19.22
<i>Dendrocalamus giganteus</i>	597	17.2	0.61	35.2	—	—	—
<i>D. hamiltonii</i>	515	40.0	2.49	43.4	—	—	—
<i>D. longispathus</i>	711	33.1	5.51	42.1	684	47.8	6.06
<i>D. membranaceus</i>	551	26.3	2.44	40.5	664	37.8	3.77
<i>D. strictus</i>	631	73.4	11.98	35.9	728	119.1	15.00
<i>Melocanna baccifera</i>	817	53.2	11.39	53.8	751	57.6	12.93
<i>Oxytenanthera</i> <i>abyssinica</i>	688	83.6	14.96	46.6	—	—	—
<i>Oxytenanthera nigrociliata</i>	510	40.70	11.7	25.2	830	51.98	12.85
<i>Thyrsostachys oliveri</i>	733	61.9	9.72	46.9	758	90.0	12.15

4.4.3.1 Air seasoning of split or half-round bamboo does not pose much problem but care has to be taken to prevent fungal discoloration and decay. However, rapid drying in open sun can control decay due to fungal and insect attack. Seasoning in round form presents considerable problem as regards mechanical degrade due to drying defects.

A general observation has been that immature bamboo gets invariably deformed in cross-section during seasoning and thick walled immature bamboo generally collapses. Thick mature bamboo tends to crack on the surface, with the cracks originating at the nodes and at the decayed points. Moderately thick immature and thin and moderately thick mature bamboos season with much less degrade. Bamboo having poor initial condition on account of decay, borer holes, etc. generally suffers more drying degrades.

4.4.3.2 Accelerated air seasoning method gives good results. In this method, the nodal diaphragms (septa) are punctured to enable thorough passage of hot air from one end of the resulting bamboo tube to the other end.

4.4.4 Grading of Structural Bamboo

Grading is sorting out bamboo on the basis of characteristics important for structural utilization as under:

- (a) Diameter and length of culm,
- (b) Taper of culm,
- (c) Straightness of culm,
- (d) Inter nodal length,
- (e) Wall thickness,
- (f) Density and strength, and
- (g) Durability and seasoning.

One of the above characteristics or sometimes combination of 2 or 3 characteristics form the basis of grading. The culms shall be segregated species-wise.

Table 6.4.6: Safe Working Stresses of Bamboos for Structural Designing⁽¹⁾

Species	Extreme Fibre Stress in Bending N/mm ²	Modulus of Elasticity 10 ³ N/mm ²	Allowable Compressive Stress N/mm ²
GROUP A			
<i>Bambusa glaucescens</i> (syn. <i>B. nana</i>)	20.7	3.28	15.4
<i>Dendrocalamus strictus</i>	18.4	2.66	10.3
<i>Oxytenanthera abyssinica</i>	20.9	3.31	13.3

Species	Extreme Fibre Stress in Bending N/mm ²	Modulus of Elasticity 10 ³ N/mm ²	Allowable Compressive Stress N/mm ²
GROUP B			
Bambusa balcooa	16.05	1.62	13.3
B. pallida	13.8	2.87	15.4
B. nutans	13.2	1.47	13.0
B. tulda	13.3	1.77	11.6
B. auriculata	16.3	3.34	10.5
B. burmanica	14.9	2.45	11.4
Cephalostachyum pergracile	13.2	2.48	10.5
Melocanna baccifera (Syn. M. bambusoides)	13.3	2.53	15.4
Thyrsotachys oliveri	15.5	2.16	13.4
GROUP C			
Bambusa arundinacea (Syn. B. bambos)	14.6	1.32	10.1
B. polymorpha	9.15	1.71	8.97
B. ventricosa	8.5	0.75	10.3
B. vulgaris	10.4	0.64	11.0
Dendrocalamus longispathus	8.3	1.22	12.0
Oxytenanthera nigrociliata	10.18	2.6	7.2
⁽¹⁾ The values given pertain to testing of bamboo in green condition.			

Table 6.4.7: Limiting Strength Values (in Green Condition)

	Modulus of Rupture (R') N/mm ²	Modulus of Elasticity (E) in Bending 10 ³ N/mm ²
Group A	$R' > 70$	$E > 9$
Group B	$70 \geq R' > 50$	$9 \geq E > 6$
Group C	$50 \geq R' > 30$	$6 \geq E > 3$

Table 6.4.8: Allowable Long-Term Stress (N/mm²) Per Unit Density (kg/m³)

Condition	Axial Compression (no buckling)	Bending	Shear
Green	0.011	0.015	—
Air dry (12%)	0.013	0.020	0.003

Note: In the laboratory regime, the density of bamboo is conveniently determined. Having known the density of any species of bamboo, permissible stresses can be worked out using factors indicated above. For example, if green bamboo has a density of 600 kg/m³, the allowable stress in bending would be 0.015 x 600 = 9 N/mm².

4.4.4.1 Diameter and length

4.4.4.1.1 Gradation according to the Mean Outer Diameter

For structural Group A and Group B species, culms shall be segregated in steps of 10 mm of mean outer diameter as follows:

- Special Grade 70mm<Diameter <100mm
- Grade I 50mm<Diameter <70mm
- Grade II 30mm<Diameter <50mm
- Grade III Diameter <30mm

For structural Group C species culms shall be segregated in steps of 20 mm of mean outer diameter

- Grade I 80 mm < Diameter <100 mm
- Grade II 60 mm < Diameter < 80 mm
- Grade III Diameter <60 mm

4.4.4.1.2 The minimum length of culms shall be preferably 6 m for facilitating close fittings at joints.

4.4.5 Taper

The taper shall not be more than 5.8 mm per metre length (or 0.58 percent) of bamboo in any grade of bamboo.

4.4.5.1 Curvature

The maximum curvature shall not be more than 75 mm in a length of 6 m of any grade of bamboo.

4.4.5.2 Wall thickness

Preferably minimum wall thickness of 8 mm shall be used for load bearing members.

4.4.5.3 Defects and permissible characteristics

4.4.5.3.1 Dead and immature bamboos, bore/GHOON holes, decay, collapse, checks more than 3 mm in depth, shall be avoided.

4.4.5.3.2 Protruded portion of the nodes shall be flushed smooth. Bamboo shall be used after at least six weeks of felling.

4.4.5.3.3 Broken, damaged and discolored bamboo shall be rejected.

4.4.5.3.4 Matured bamboo of at least 4 years of age shall be used.

4.4.6 Durability and Treatability

4.4.6.1 Durability

The natural durability of bamboo is low and varies between 12 months and 36 months depending on the species and climatic conditions. In tropical countries the bio-deterioration is very severe, Bamboos are generally destroyed in about one to two years' time when used in the open and in contact with ground while a service life of two to five years can be expected from bamboo when used under cover and out of contact with ground. The mechanical strength of bamboo deteriorates rapidly with the onset of fungal decay in the sclerenchymatous fibres. Split bamboo is more rapidly destroyed than round bamboo. For making bamboo durable, suitable treatment shall be given.

4.4.6.2 Treatability

Due to difference in the anatomical structure of bamboo as compared to timber, bamboo behaves entirely differently from wood during treatment with preservative. Bamboos are difficult to treat by normal preservation methods in dry condition and therefore treatment is best carried out in green condition.

4.4.6.3 Boucherie Process

In this process of preservative treatment, water borne preservative is applied to end surface of green bamboo through a suitable chamber and forced through the bamboo by hydrostatic or other pressure.

4.4.6.3.1 Performance of treated bamboo

Trials with treated bamboos have indicated varied durability depending upon the actual location of use. The performance in partially exposed and under covered conditions is better.

4.4.6.3.2 For provisions on safety of bamboo structures against fire, see Part 7.

4.5 Permissible Stresses

4.5.1 Factor of Safety

The safety factor for deriving stresses of bamboo shall be as under:

Extreme fibre stress in beams	4
Modulus of elasticity	4.5
Maximum compressive stress parallel to grain/fibres	3.5

4.5.2 Coefficient of Variation

The coefficient of variation (in percent) shall be as under:

<u>Property</u>	<u>Mean</u>	<u>Range</u>	<u>Maximum Expected Value</u>
Modulus of rupture	15.9	5.7-28.3	23.4
Modulus of elasticity	21.1	12.7-31.7	27.4
Maximum compressive stress	14.9	7.6-22.8	20.0

The maximum expected values of coefficient of variation which are the upper confidence limits under normality assumption such that with 97.5 percent confidence the actual strength of the bamboo culms will be at least 53 percent of the average reported value of modulus of rupture in Table 6.4.5.

4.5.3 Solid bamboos or bamboos whose wall thickness (w) is comparatively more and bamboos which are generally known as male bamboos having nodes very closer and growing on ridges are often considered good for structural purposes.

4.5.4 The safe working stresses for 18 species of bamboos are given in Table 4.5.6

4.5.5 For change in duration of load other than continuous (long-term), the permissible stresses given in Table 4.5.6 shall be multiplied by the modification factors given below:

For imposed or medium term loading	1.25
For short-term loading	1.50

4.6 Design Considerations

4.6.1 All structural members, assemblies or framework in a building shall be capable of sustaining, without exceeding the limits of stress specified, the worst combination of all loadings. A fundamental aspect of design will be to determine the forces to which the structure/structural element might be subjected to, starting from the roof and working down to the soil by transferring the forces through various components and connections. Accepted principles of mechanics for analysis and specified design procedures shall be applied (see Chapter 11 Part 6).

4.6.2 Unlike timber, bamboo properties do not relate well to species, being dependent among other factors, on position of the culm, geographic location and age. The practice in timber engineering is to base designs on safe working stresses and the same may be adopted to bamboo with the limitations that practical experience rather than precise calculations generally govern the detailing.

4.6.3 Net Section

It is determined by passing a plane or a series of connected planes transversely through the members. Least net sectional area is used for calculating load carrying capacity of a member.

4.6.4 Loads

The loads shall be in accordance with Chapter 2 Part 6.

4.6.5 Structural Forms

4.6.5.1 Main structural components in bamboo may include roof and floor diaphragms, shear walls, wall panellings, beams, piles, columns, etc. Both from the point of view of capacity and deformation, trusses and framed skeletons are much better applications of bamboo.

4.6.5.2 Schematization of bamboo as a structural material

This shall be based on the principles of engineering mechanics involving the following assumptions and practices:

- (a) The elastic behaviour of bamboo, till failure; (plastic behaviour being considered insignificant);
- (b) Bamboo culms are analysed on mean wall thickness basis as hollow tube structure (not perfectly straight) member on mean diameter basis;
- (c) The structural elements of bamboo shall be appropriately supported near the nodes of culm as and where the structural system demands. The joints in the design shall be located near nodes; and

- (d) Bamboo structures be designed like any other conventional structural elements taking care of details with regards to supports and joints; they shall be considered to generally act as a hinge, unless substantiating data justify a fixed joint.

4.6.6 Flexural Members

4.6.6.1 All flexural members maybe designed using the principles of beam theory.

4.6.6.2 The tendency of bamboo beams to acquire a large deflection under long continuous loadings due to possible plastic flow, if any shall be taken care of. Permanent load may be doubled for calculation of deflection under sustained load (including creep) in case of green bamboo having moisture content exceeding 15 percent.

4.6.6.3 The moment of inertia, I shall be determined as follows:

- (a) The outside diameter and the wall thickness should be measured at both ends, correct up to 1 mm for diameter of culm and 0.1 mm for the wall thickness. (For each cross-section the diameter shall be taken twice, in direction perpendicular to each other and so the wall thickness shall be taken as four times, in the same places as the diameter has been taken twice.)
- (b) With these values the mean diameter and the mean thickness for the middle of the beam shall be calculated and moment of inertia determined.

4.6.6.4 The maximum bending stress shall be calculated and compared with the allowable stress.

4.6.6.5 For shear checks, conventional design procedure in accordance with Chapter 11 Part 6 shall be followed. The basic shear stress values (N/mm^2) for five species of bamboo in split form in green condition can be assumed as under:

Bambusa pallida	9.77
B. Vulgaris	9.44
Dedroculumus giganteous	8.86
D. humiltonii	7.77
Oxytenanthera abyssinicia	11.2

4.6.6.6 Forces acting on a beam, being loads or reaction forces at supports, shall act in nodes or as near to nodes as by any means possible.

4.6.7 Bamboo Column (Predominantly Loaded in Axial Direction)

4.6.7.1 Columns and struts are essential components sustaining compressive forces in a structure. They transfer load to the supporting media.

4.6.7.2 Design of columns shall be based on one of the following two criteria:

- (a) Full scale buckling tests on the same species, size and other relevant variables.
- (b) Calculations, based on the following:
 - (i) The moment of inertia shall be as per Sec 4.6.6.3.
 - (ii) For bamboo columns the best available straight bamboo culms shall be selected. Structural bamboo components in compression should be kept under a slenderness ratio of 50.
 - (iii) The bending stresses due to initial curvature, eccentricities and induced deflection shall be taken into account, in addition to those due to any lateral load.

4.6.7.3 Buckling calculation shall be according to Euler, with a reduction to 90 percent of moment of inertia, to take into account the effect of the taper, provided the reduced diameter is not less than 0.6 percent.

4.6.7.4 For strength and stability, larger diameter thick walled sections of bamboo with closely spaced nodes shall be used, alternatively, smaller sections may be tied together as a bundle-column.

4.6.8 Assemblies, Roof Trusses

4.6.8.1 A truss is essentially a plane structure which is very stiff in the plane of the members, that is the plane in which it is expected to carry load, but very flexible in every other direction. Roof truss generally consists of a number of triangulated frames, the members of which are fastened at ends and the nature of stresses at joints are either tensile or compressive and designed as pin-ended joints [see Figure 6.4.1(a)]. Bamboo trusses may also be formed using bamboo mat board or bamboo mat-veneer composite or plywood gusset [see Figure 6.4.1(b)].

4.6.8.2 Truss shall be analysed from principles of structural mechanics for the determination of axial forces in members. For the influence of eccentricities, due allowance shall be made in design.

4.6.8.3 The truss height shall exceed 0.15 times the span in case of a triangular truss (pitched roofing) and 0.10 times the span in case of a rectangular (parallel) truss.

4.6.8.4 For members in compression, the effective length for in-plane strength verification shall be taken as the distance between two adjacent points of contraflexure. For fully triangulated trusses, effective length for simple span members without especially rigid end-connection shall be taken as the span length.

4.6.8.5 For strength verification of members in compression and connections, the calculated axial forces should be increased by 10 percent.

4.6.8.6 The spacing of trusses shall be consistent with use of bamboo purlins (2 m to 3 m).

4.6.8.7 The ends in open beams, joists, rafters, purlins shall be suitably plugged. Bamboo roof coverings shall be considered as non-structural in function. The common roof covering shall include bamboo mat board, bamboo mat corrugated sheet, bamboo tiles/strings, plastered bamboo reeds, thatch, corrugated galvanized iron sheeting, plain clay tiles or pan tiles, etc.

4.7 Design and Techniques of Joints

4.7.1 Bamboo Joints

Round, tubular form of bamboo requires an approach different to that used for sawn timber. Susceptibility to crushing at the open ends, splitting tendency, variation in diameter, wall thickness and straightness are some of the associated issues which have to be taken care of while designing and detailing the connections with bamboo.

4.7.1.1 Traditional practices

Such joining methods revolve around lashing or tying by rope or string with or without pegs or dowels. Such joints lack stiffness and have low efficiency.

4.7.1.1.1 Lengthening joints (End Joints)

(a) Lap Joint

In this case, end of one piece of bamboo is made to lap over that of the other in line and the whole is suitably fastened. It may be full lapping or half lapping. Full section culms are overlapped by at least one internode and tied together in two or three places. Efficiency could be improved by using bamboo or hardwood dowels. In half lapping, culms shall preferably be of similar diameter and cut longitudinally to half depth over at least one internode length and fastened as per full lap joint (Figure 6.4.2).

(b) Butt Joint

Culms of similar diameter are butted end to end, interconnected by means of side plates made of quarter round culm of slightly large diameter bamboo, for two or more internode lengths. Assembly shall be fixed and tied preferably with dowel pins. This joint transfers both compressive and tensile forces equally well (Figure 6.4.3).

(c) Sleeves and Inserts

Short length of bamboo of appropriate diameter may be used either externally or internally to join two culms together (Figure 6.4.4).

(d) Scarf Joint

A scarf joint is formed by cutting a sloping plane 1 in 4 to 6 on opposite sides from the ends of two similar diameter bamboo culms to be joined. They shall be lapped to form a continuous piece and the assembly suitably fastened by means of lashings. Using hooked splays adds to the strength and proper location of joints (Figure 6.4.5).

4.7.1.1.2 Bearing joints

Bearing joints are formed when members which bear against one another or cross each other and transfer the loads at an angle other than parallel to the axis.

(a) Butt Joint

The simplest form consists of a horizontal member supported directly on top of a vertical member. The top of the post may be cut to form a saddle to ensure proper seating of beam for good load transfer. The saddle should be close to a node to reduce risk of splitting (Figure 6.4.6).

(b) Tenon Joint

It is formed by cutting a projection (tenon) in walls of one piece of bamboo and filling it into corresponding holes (mortise) in another and keyed. It is a neat and versatile joint for maximum strength and resistance to separation (Figure 6.4.7).

(c) Cross-Over Joint

It is formed when two or more members cross at right angles and its function is to locate the members and to provide lateral stability. In case of the joint connecting floor beam to post, it may be load bearing (see Figure 6.4.8). Such joints are also used to transmit angle thrust.

(d) Angled Joint

When two or more members meet or cross other than at right angles, angled joints are formed. For butt joints, the ends of the members may be shaped to fit in as saddle joints. Tenons would help in strengthening such joints (see Figure 6.4.9).

4.7.1.2 Modern practices

Following are some of the modern practices for bamboo jointing (Figure 6.4.10):

- (a) Plywood or solid timber gusset plates maybe used at joint assemblies of web and chord connection in a truss and fixed with bamboo pins or bolts. Hollow cavities of bamboo need to be stuffed with wooden plugs.
- (b) Use of wooden inserts to reinforce the ends of the bamboo before forming the joints. Alternatively steel bands clamps with integral bolt/eye may be fitted around bamboo sections for jointing.

4.7.1.3 Fixing methods and fastening devices

In case of butt joints the tie maybe passed through a pre-drilled hole or around hardwood or bamboo pegs or dowels inserted into prefomed holes to act as horns. Pegs are driven from one side, usually at an angle to increase strength and dowels pass right through the member, usually at right angles.

4.7.1.3.1 Normally 1.60 mm diameter galvanized iron wire may be used for tight lashing.

4.7.1.3.2 Wire Bound Joints

Usually galvanized iron 2.00 mm diameter galvanized iron wire is tightened around the joints by binding the respective pieces together. At least two holes are drilled in each piece and wire is passed through them for good results.

4.7.1.3.3 Pin And Wire Bound Joints

Generally 12 mm diameter bamboo pins are fastened to culms and bound by 2.00 mm diameter galvanized iron wire.

4.7.1.3.4 Fish Plates/Gusset Plated Joints

At least 25 mm thick hardwood splice plate or 12 mm thick structural grade plywood are used. Solid bamboo pins help in fastening the assembly.

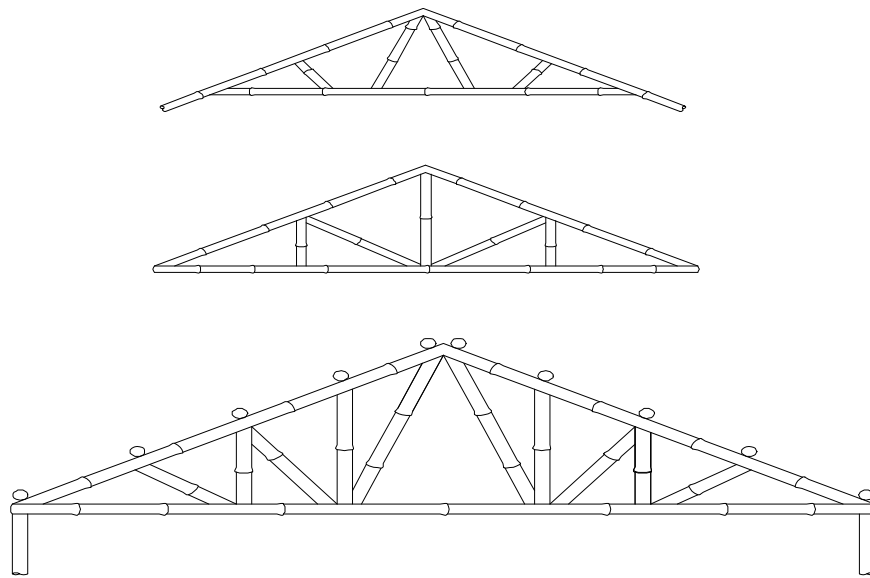
4.7.1.3.5 Horned Joints

Two tongues made at one end of culm may be fastened with across member with its mortise grooves to receive horns, the assembly being wire bound.

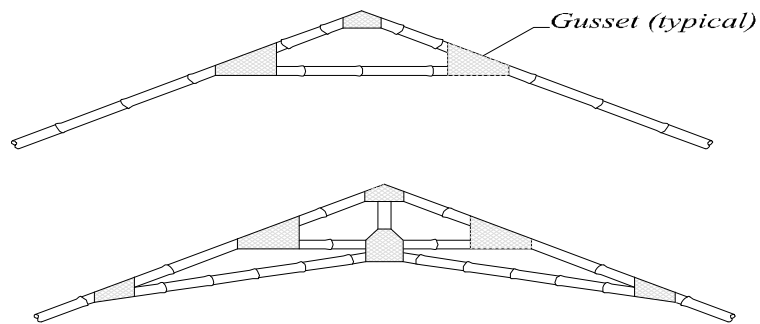
4.7.1.4 For any complete joint alternative for a given load and geometry, description of all fastening elements, their sizes and location shall be indicated. Data shall be based on full scale tests.

4.7.1.5 Tests on full scale joints or on components shall be carried out in a recognized laboratory.

4.7.1.6 In disaster high wind and seismic areas, good construction practice shall be followed taking care of joints, their damping and possible ductility. Bracings in walls shall be taken care of in bamboo structures.



6.4.1(a)- Pin ended joint trusses



6.4.1(b)- Gusset joint trusses

Figure 6.4.1 Some typical configurations for small and large trusses in Bamboo

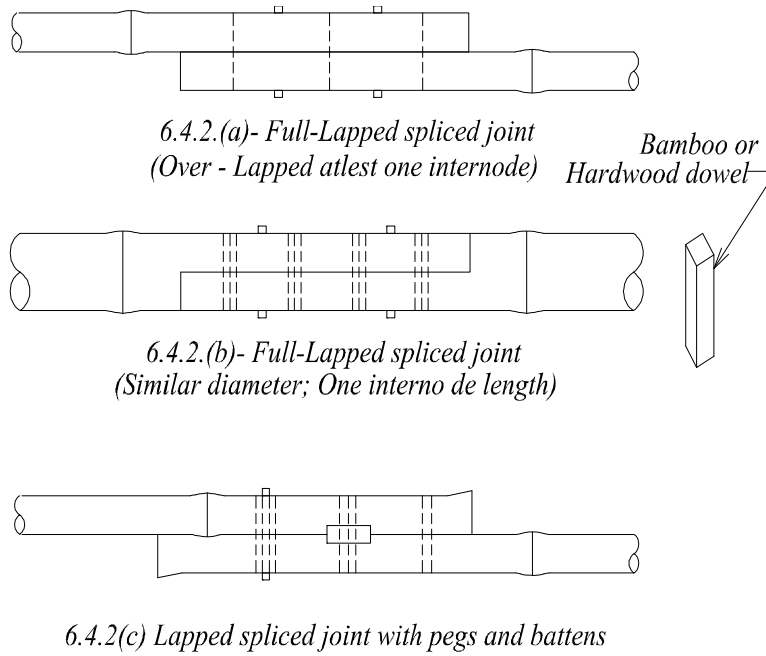


Figure 6.4.2 Lap joint in Bamboo

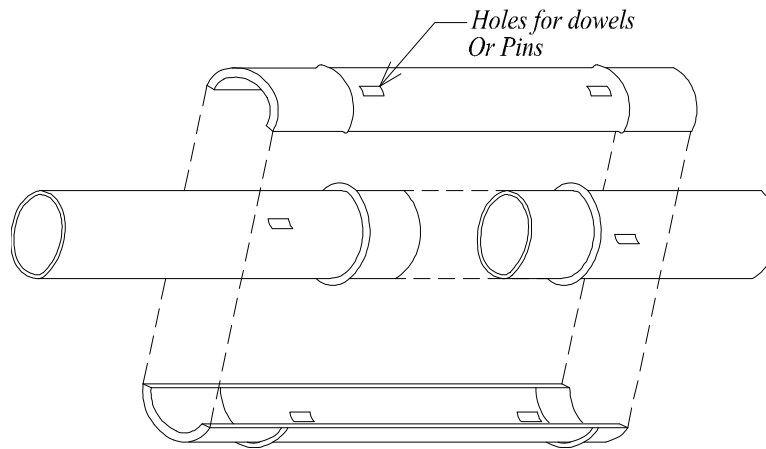


Figure 6.4.3 Butt joint with side plates in Bamboo

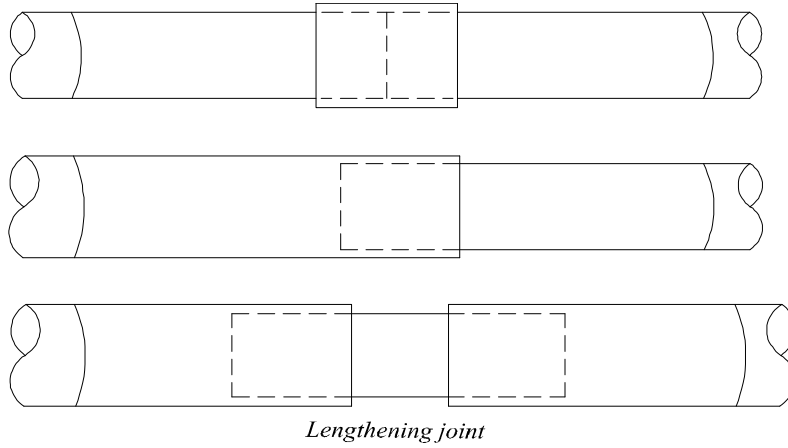


Figure 6.4.4 Sleeves and inserts for Bamboo joint

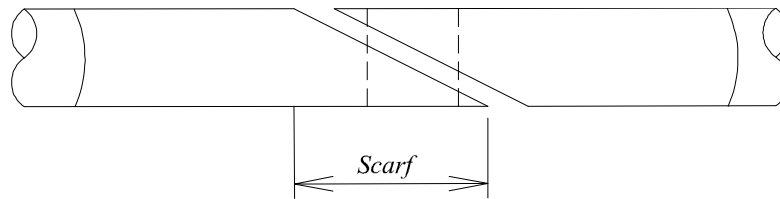
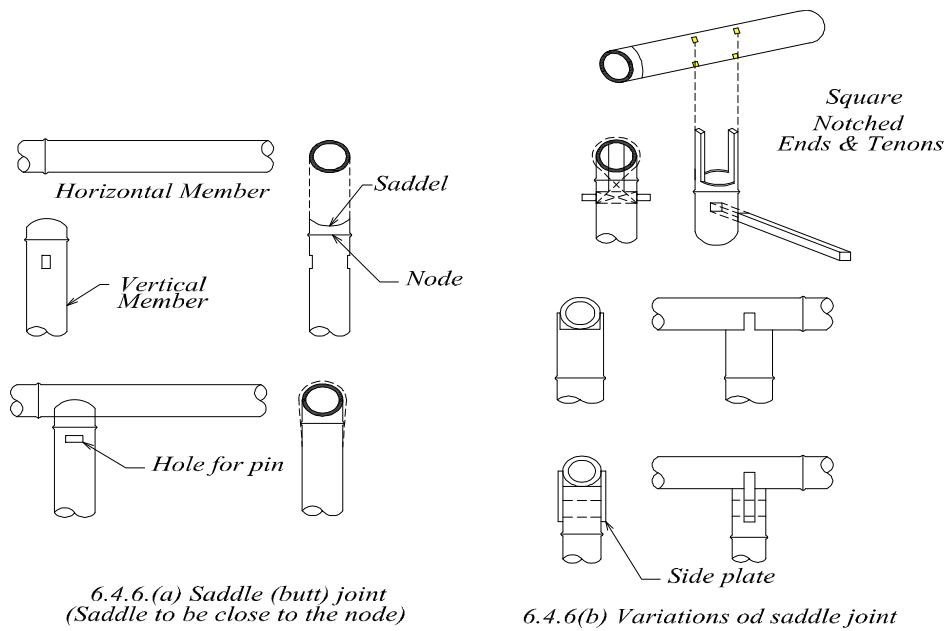


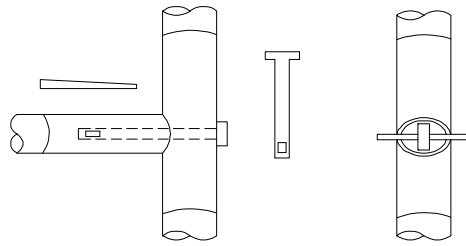
Figure 6.4.5 Scarf joint



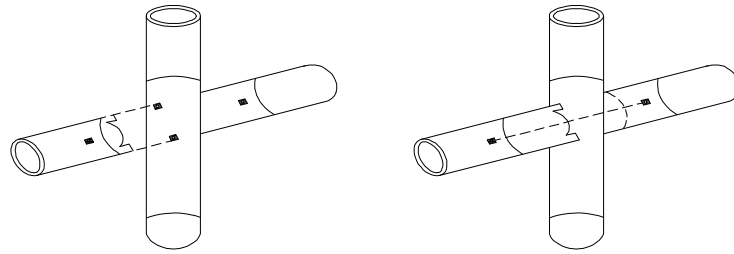
6.4.6.(a) Saddle (butt) joint
(Saddel to be close to the node)

6.4.6.(b) Variations of saddle joint

Figure 6.4.6 Butt joints in Bamboo



Tenon and key joint



Integral tenon (horned) joint

Figure 6.4.7 Tenon joint

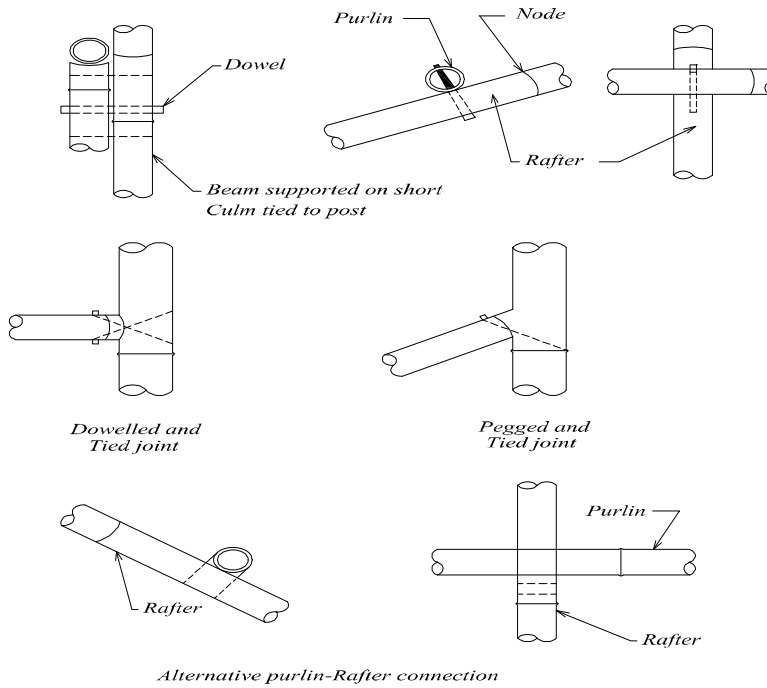


Figure 6.4.8 Cross over joints (Bearing joints)

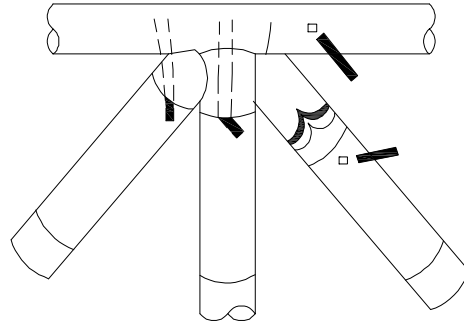


Figure 6.4.9 Angled joints with integral tenons

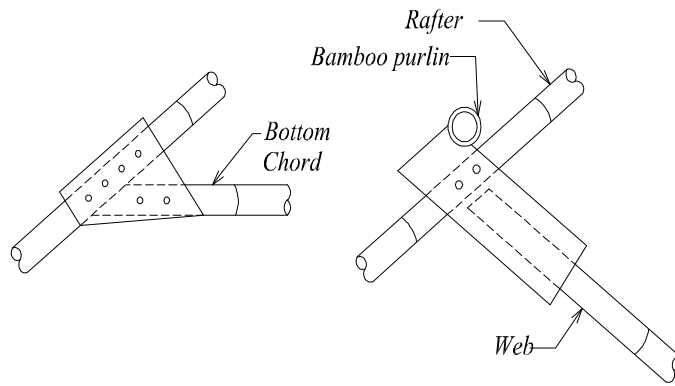


Figure 6.4.10 Gusset plated joint

4.8 Storage of Bamboo

Procurement and storage of bamboo stocks are essential for any project work and shall be done in accordance with Part 7 of this Code.

4.9 Related References

- (1) IS 6874: 1973, “Method of Test for Round Bamboo”, Bureau of Indian Standards, India, 1974.
- (2) IS 9096: 1979, “Code of Practice for Preservation of Bamboo for Structural Purposes”, Bureau of Indian Standards, India, 1974.
- (3) Salehuddin, A. B. M., “Unnoto Poddhotite Bash Shongrokkhon o Babohar”, Bangladesh Agriculture Research Institute, 2004.

PART VI
Chapter 5
Concrete Material

5.1 General

5.1.1 Scope

The provisions of this Chapter shall apply to the design of reinforced and prestressed concrete structures specified in Chapters 6, 8, 9 shall be applicable for normal weight aggregate only unless otherwise specified.

5.1.2 Notation

C_c	=	Creep coefficient
E_c	=	Modulus of elasticity of concrete
E_s	=	Modulus of elasticity of reinforcement
E_t	=	Modulus of elasticity of concrete at the age of loading t
f'_c	=	Specified compressive strength of concrete
f'_{cr}	=	Required average compressive strength of concrete used as the basis for selection of concrete proportions
f_y	=	Specified yield strength of reinforcement
K	=	Coefficient of shrinkage
s	=	Standard deviation
W_c	=	Unit weight of concrete
ϵ_{cc}	=	Creep strain in concrete
ϵ_{sh}	=	Shrinkage of plain concrete
ρ	=	Area of steel relative to that of the concrete.

5.2 Constituents Of Concrete

5.2.1 Cement

5.2.1.1 Cement shall conform to one of the following specifications:

- (a) "Composition, Specification and Conformity Criteria for Common Cements" (BDS EN 197-1:2003)
- (b) "Standard Specification for Portland Cement" (ASTM C150/C150M)
- (c) "Standard Specification for Blended Hydraulic Cements" (ASTM C595/C595M)
- (d) "Standard Performance Specification for Hydraulic Cement" (ASTM C1157/C1157M)

5.2.1.2 Cement used in the construction shall be the same as that used in the concrete mix design.

5.2.2 Aggregates

- 5.2.2.1 Concrete aggregates shall conform to the standards “Coarse and Fine Aggregates from Natural Sources for Concrete” (BDS 243: 1963); “Standard Specification for Concrete Aggregates” (ASTM C33/C33M).
- 5.2.2.2 Maximum nominal size of coarse aggregate shall be the minimum of the following:
- One fifth (1/5) the narrowest dimension between sides of forms,
 - One third (1/3) the depth of slabs,
 - Three fourth (3/4) the minimum clear spacing between individual reinforcing bars, or bundles of bars, or prestressing tendons or ducts.

The above limitations may be relaxed if, in the judgment of the engineer, workability and methods of consolidation are such that concrete can be placed without honeycomb or voids.

5.2.2.3 Coarse aggregate made from Grade A brick as specified in BDS 208 "Specification for Common Building Clay Bricks" may be used in different types slab and non-structural elements, except in applications where the ambient environmental conditions may impair the performance of concrete made of such aggregates.

5.2.3 Water

- 5.2.3.1 Water used in mixing concrete shall be clean and free from injurious amounts of oils, acids, alkalis, salts, organic materials, or other substances that may be harmful to concrete or reinforcement.
- 5.2.3.2 For concrete wherein aluminium members will be embedded, mixing water shall not contain harmful amounts of chloride ion as indicated in Sec 5.5.3.
- 5.2.3.3 Nonpotable water shall not be used in concrete except the following conditions:
- Selection of concrete proportions shall be based on concrete mixes using water from the same source.
 - Nonpotable water is permitted only if specified comparative mortar test cubes made with nonpotable water produce at least 90 percent of the strength achieved with potable water.

5.2.4 Admixtures

5.2.4.1 Prior approval of the engineer shall be required for the use of admixtures in concrete. All admixtures shall conform to the requirements of this Section and Sec 2.4.5 Chapter 2 Part 5.

5.2.4.2 Admixture used in the work shall be the same as that used in the concrete mix design.

5.2.4.3 Admixtures containing chloride other than impurities from admixture ingredients shall not be used in concrete containing embedded aluminium, or in concrete cast against permanent galvanized metal forms (see Sections 5.5.1.2 and 5.5.2.1).

5.2.4.4 Air entraining admixtures, if used in concrete, shall conform to "Specification for Air entraining Admixtures for Concrete" (ASTM C260).

5.2.4.5 Water reducing admixtures, retarding admixtures, accelerating admixtures, water reducing and retarding admixtures, and water reducing and accelerating admixtures, if used in concrete, shall conform to "Standard Specification for Chemical Admixtures for Concrete" (ASTM C494/C494M) or "Standard Specification for Chemical Admixtures for use in Producing Flowing Concrete" (ASTM C1017/C1017M).

5.2.4.6 Fly ash or other pozzolans used as admixtures shall conform to "Standard Specification for Fly Ash and Raw or Calcined Natural Pozzolan for use as a Mineral Admixture in Portland Cement Concrete" (ASTM C618).

5.2.4.7 Ground granulated blast-furnace slag used as an admixture shall conform to "Standard Specification for Ground Iron Blast Furnace Slag for use in Concrete and Mortar" (ASTM C989).

5.3 Steel Reinforcement

5.3.1 General

5.3.1.1 Steel reinforcement for concrete shall conform to the provisions of this Section and those of Sec 2.4.6 Chapter 2 Part 5.

5.3.1.2 Modulus of elasticity E_s for reinforcement shall be taken as 200 kN/mm².

5.3.1.3 Reinforcing bars to be welded shall be indicated on the drawings and welding procedure to be used shall be specified. Reinforcing bars otherwise conforming to BDS ISO 6935-2, shall also possess material properties necessary to conform to welding procedures specified in "Structural Welding Code - Reinforcing Steel" (AWS D1.4) of the American Welding Society.

5.3.2 Deformed Reinforcement

5.3.2.1 Deformed reinforcing bars shall conform to one of the following specifications:

- (a) "Bangladesh Standard Steel for the reinforcement of concrete Part-1; Plain bars" (BDS ISO 6935-1 and "Bangladesh Standard Steel for the reinforcement of concrete Part-2; Ribbed bars" (BDS ISO 6935-2)
- (b) "Standard Specification for Deformed and Plain Billet Steel Bars for Concrete Reinforcement" (ASTM A615/A615M),
- (c) "Standard Specification for Rail Steel Deformed and Plain Bars for Concrete Reinforcement" Including Supplementary Requirements S1 (ASTM A996/A996M),
- (d) "Standard Specification for Axle Steel Deformed and Plain Bars for Concrete Reinforcement" (ASTM A996/A996M),
- (e) "Standard Specification for Low Alloy Steel Deformed Bars for Concrete Reinforcement" (ASTM A706/A706M),
- (f) "Specification for Cold Worked Steel Bars for the Reinforcement of Concrete" (BS 4461).

5.3.2.2 Deformed reinforcing bars with a specified yield strength f_y exceeding 420 N/mm² shall be permitted, provided f_y shall be the stress corresponding to a strain of 0.35 percent and the bars otherwise conform to one of the ASTM specifications listed in Sec 5.3.2.1 (Also see Sec 6.1.2.5).

5.3.2.3 Galvanized reinforcing bars shall comply with "Standard Specification for Zinc Coated (Galvanized) Steel Bars for Concrete Reinforcement" (ASTM A767/A767M). Epoxy coated reinforcing bars shall comply with "Standard Specifications for Epoxy Coated Reinforcing Steel Bars" (ASTM A775/A775M). Galvanized or epoxy coated reinforcement shall also conform to one of the standards listed in Sec 5.3.2.1 above.

5.3.3 Plain Reinforcement

5.3.3.1 Plain bars shall conform to one of the specifications listed in Section 5.3.2.1 (a), (b), (c) or (d).

5.3.3.2 Plain wire shall conform to "Standard Specification for Steel Wire, Plain, for Concrete Reinforcement" (ASTM A82/A82M) except that for wire with a specified yield strength f_y exceeding 420 N/mm², f_y shall be the stress corresponding to a strain of 0.0035.

5.3.3.3 Plain bars and wire may be used as ties, stirrups and spirals for all structural members and for all reinforcement in structures up to 4-storey high.

5.3.4 Structural Steel, Steel Pipe or Tubing

5.3.4.1 Structural steel used with reinforcing bars in composite compression members meeting the requirements of Sec 6.3.10.8 or Sec 6.3.10.9 of Chapter 6 of this Part shall conform to one of the following specifications:

- (a) "Standard Specification for Structural Steel" (ASTM A36/A36M),
- (b) "Standard Specification for High Strength Low Alloy Structural Steel"(ASTM A242/A242M),
- (c) "Standard Specification for High Strength Low Alloy Structural Manganese Vanadium Steel" (ASTM A572/A572M),
- (d) "Standard Specification for High Strength Low Alloy Columbium-Vanadium Steels of Structural Quality" (ASTM A572/A572M),
- (e) "Standard Specification of High Strength Low Alloy Structural Steel with 50 ksi (345 Mpa) Minimum Yield Point to 4 in (100 mm) Thick" (ASTM A588/A588M).

5.3.4.2 Steel pipe or tubing for composite compression members composed of a steel encased concrete core meeting the requirements of Sec 6.3.10.7 Chapter 6 of this Part shall conform to one of the following specifications:

- (a) Grade B of "Standard Specification for Pipe, Steel, Black and Hot Dipped, Zinc Coated Welded and Seamless" (ASTM A53/A53M).
- (b) "Standard Specification for Cold Formed Welded and Seamless Carbon Steel Structural Tubing in Rounds and Shapes" (ASTM A500/A500M).
- (c) "Standard Specification for Hot Formed Welded and Seamless Carbon Steel Structural Tubing" (ASTM A501).

5.4 Workability Of Concrete

Concrete mix proportions shall be such that the concrete is of adequate workability and can properly be compacted. Suggested ranges of values of workability of concrete for some placing conditions, are given in Table 6.5.1.

5.5 Durability Of Concrete**5.5.1 Special Exposures**

5.5.1.1 For concrete intended to have low permeability when exposed to water, the water cement ratio shall not exceed 0.50.

5.5.1.2 For corrosion protection of reinforced concrete exposed to brackish water, sea water or spray from these sources, the water cement ratio shall not exceed 0.4.

If minimum concrete cover required by Sec 8.1.8 Chapter 8 of this Part is increased by 12 mm, water cement ratio may be increased to 0.45.

5.5.1.3 The water cement ratio required in Sections 5.5.1.1 and 5.5.1.2 above and Table 6.5.2 shall be calculated using the weight of cement meeting the requirements of BDS EN-197-1 or ASTM C595/C595M or C1157/C1157M, plus the weight of fly ash or pozzolan satisfying ASTM C618 and/or slag satisfying ASTM C989, if any.

5.5.2 Sulphate Exposures

5.5.2.1 Concrete to be exposed to sulphate containing solutions or soils shall conform to the requirements of Table 6.5.2 or be made with a cement that provides sulphate resistance with the maximum water cement ratio provided in Table 6.5.2.

5.5.2.2 Calcium chloride shall not be used as an admixture in concrete exposed to severe or very severe sulphate containing solutions, as defined in Table 6.5.2.

Table 6.5.1: Suggested Workability of Concrete for Various Placing Conditions

Placing Conditions	Degree of Workability	Values of Workability
Concreting of thin sections with vibration	Very low	20-10 seconds Vee-Bee time, or 0.75-0.80 compacting factor
Concreting of lightly reinforced sections with vibration	Low	10-5 seconds Vee-Bee time, or 0.80-0.85 compacting factor
Concreting of lightly reinforced sections without vibration or heavily reinforced section with vibration	Medium	5-2 seconds Vee-Bee time, or 0.85-0.92 compacting factor, or 25-75 mm slump for 20 mm aggregate*
Concreting of heavily rein-forced sections without vibration	High	Above 0.92 compacting factor, or 75-125 mm slump for 20 mm aggregate*

* Slump test shall be performed as per ASTM C143. For smaller aggregates the values will be lower.

Table 6.5.2: Requirements for Normal Weight Aggregate Concrete Exposed to Sulphate Containing Solutions

Sulphate Exposure	Water Soluble Sulphate (SO ₄) in Soil, percent by Weight	Sulphate (SO ₄) in Water, (ppm)	Cement Type ¹	Maximum Water Cement Ratio, by Weight
Negligible	0.00-0.10	0 – 150	-	-
Moderate ²	0.10-0.20	150 -1500	Other than CEM I and B type	0.50
Severe	0.20-2.00	1500 -10,000	Other than CEM-I and B type	0.45
Very severe	Over 2.00	Over 10,000	Other than CEM-I and B type	0.45

Notes: Pozzolan that has been determined by test or service record to improve sulphate resistance when used in concrete containing Type V cement.

¹ For types of cement see BDS EN 197-1:2003 or ASTM C150 and C595

² Sea water

Table 6.5.3: Maximum Chloride-ion Content for Corrosion Protection

Type of Member	Maximum Water Soluble Chloride Ion (Cl ⁻) in Concrete, Percent by Weight of Cement
Prestressed concrete	0.06
Reinforced concrete exposed to chloride in service	0.15
Reinforced concrete that will be dry or protected from moisture in service	1.00
Other reinforced concrete construction	0.30

5.5.3 Corrosion of Reinforcement

5.5.3.1 For corrosion protection, maximum water soluble chloride ion concentrations in hardened concrete at ages from 28 to 42 days contributed from the ingredients including water, aggregates, cementitious materials, and admixtures, shall not exceed the limits of Table 6.5.3. When testing is performed to determine water soluble chloride ion content, test procedure shall conform to AASHTO T260, "Methods of Sampling and Testing for Total Chloride Ion in Concrete and Concrete Raw Materials".

5.5.3.2 When reinforced concrete will be exposed to brackish water, sea water, or spray from these sources, requirements of Sections 5.5.1.1 and 5.5.1.2 for water cement ratio, or concrete strength and minimum cover requirements of Sec 8.1.8 Chapter 8 of this Part shall be satisfied.

5.5.4 Minimum Concrete Strength

Minimum concrete strength for structural use of reinforced concrete shall be 20 N/mm². However, for buildings up to 4 storey, the minimum concrete strength may be relaxed to 17 N/mm².

5.6 Concrete Mix Proportion

5.6.1 General

5.6.1.1 Proportions of materials for concrete shall be such that :

- (a) Workability and consistency are achieved for proper placement into forms and around reinforcement, without segregation or excessive bleeding;
- (b) Resistance to special exposures to meet the durability requirements of Sec 5.5 are provided; and
- (c) Conformance with strength test requirements of Sec 5.12 is ensured.

5.6.1.2 Where different materials are to be used for different portions of the proposed work, each combination shall be evaluated.

5.6.1.3 Concrete proportions, including water cement ratio, shall be established on the basis of field experience and/or trial mixtures with materials to be employed (Sec 5.6.2) except as permitted in Sec 5.6.3 or required by Sec 5.5.

5.6.2 Proportioning Concrete Mix on the Basis of Field Experience and/or Trial Mixtures

5.6.2.1 Standard deviation

- (a) A standard deviation shall be established where test records are available in a concrete production facility. Test records from which a standard deviation is calculated shall meet the following requirements :
 - (i) These shall represent materials, quality control procedures, and conditions similar to those expected for the proposed work. Deviations in materials and proportions for the proposed work shall be more restricted than those within the test records.

- (ii) Test records shall represent concrete produced to meet a specified strength f'_c within 7 N/mm² of that specified for the proposed work.
- (iii) The record shall consist of at least 30 consecutive tests or two groups of consecutive tests totaling at least 30 tests as defined in Sec 5.12.2.4 except as provided in (b) below.
- (b) Where a concrete production facility does not have test records meeting the requirements of (a) above but does have a record based on 15 to 29 consecutive tests, a standard deviation shall be established as the product of the calculated standard deviation and the modification factor specified in Table 6.5.4. However, the test records shall meet the requirements (i) and (ii) of (a) above and represent only a single record of consecutive tests that span a period of not less than 45 calendar days.

Table 6.5.4: Modification Factor for Standard Deviation when Less Than 30 Tests are Available

No. of Tests*	Modification Factor for Standard Deviation**
Less than 15	See Section 5.6.2.2(b)
15	1.16
20	1.08
25	1.03
30 or more	1.00

* Interpolate for intermediate numbers of tests

** Modified standard deviation to be used to determine the required average strength f'_{cr} from Sec 5.6.2.2(a).

5.6.2.2 Required average strength

- (a) Required average compressive strength f'_c used as the basis for selection of concrete proportions shall be the larger of the values given by Eq (6.5.1) and (6.5.2) using a standard deviation calculated in accordance with Sec 5.6.2.1(a) or Sec 5.6.2.1(b) above.

$$f'_{cr} = f'_c + 1.34s \quad (6.5.1)$$

$$f'_{cr} = f'_c + 2.33s - 3.5 \quad (6.5.2)$$

- (b) When a concrete production facility does not have field strength test records for calculation of standard deviation meeting the requirements of Sec 5.6.2.1(a) or Sec 5.6.2.1(b), the required average strength shall be determined from Table 6.5.5 and documentation of the average strength shall be in accordance with the requirements of Sec 5.6.2.3 below.

Table 6.5.5: Required Average Compressive Strength when Data are not available to establish a Standard Deviation

Specified Compressive Strength f'_c N/mm ²	Required Average Compressive Strength, f'_{cr} N/mm ²
Less than 20	$f'_c + 7.0$
20 to 35	$f'_c + 8.5$
Over 35	$f'_c + 10.0$

5.6.2.3 Documentation of average strength

Documentation shall be prepared to demonstrate that the proposed concrete proportions will produce an average compressive strength equal to or greater than the required average compressive strength (Sec 5.6.2.2). Such documentation shall consist of one or more field strength test records or trial mixtures.

- (a) When test records are used to demonstrate that proposed concrete proportions will produce the required average strength f'_{cr} (Sec 5.6.2.2) such records shall represent materials and conditions similar to those expected. Deviations in materials, conditions and proportions within the test records shall not have been more restricted than those for proposed work. For the purpose of documenting average strength potential, test records consisting of less than 30 but not less than 10 consecutive tests are acceptable provided the test records encompass a period of time not less than 45 days. Required concrete proportions shall be permitted to be established by interpolation between the strengths and proportions of two or more test records each of which meets other requirements of this Section.
- (b) When an acceptable record of field test results is not available, concrete proportions may be established based on trial mixtures meeting the following restrictions :
- (i) Combination of materials shall be those for the proposed work.
 - (ii) Trial mixtures having proportions and consistencies required for the proposed work shall be made using at least three different water cement ratios or cement contents that will produce a range of strengths encompassing the required average strength.

- (iii) Trial mixtures shall be designed to produce a slump within ± 20 mm of the maximum permitted, and for air entrained concrete the air content shall be within ± 0.5 percent of the maximum allowable.
- (iv) For each water cement ratio or cement content, at least three test cylinders for each test age shall be made and cured in accordance with "Method of Making and Curing Concrete Test Specimens in the Laboratory" (ASTM C192/C192M). Cylinders shall be tested at 28 days or at test age designated for the determination of f'_c .
- (v) From the results of cylinder tests, a curve shall be plotted showing the relationship between the water cement ratio or cement content and the compressive strength at designated test age.
- (vi) Maximum water cement ratio or minimum cement content for concrete to be used in the proposed work shall be that shown by the above curve to produce the average strength required by Sec 5.6.2.2 unless a lower water cement ratio or higher strength is required by Sec 5.5.

5.6.3 Proportioning by Water Cement Ratio

5.6.3.1 If the data required in Sec 5.6.2 are not available, concrete proportions shall be based on water cement ratio limits specified in Table 6.5.6 when approved by the engineer.

5.6.3.2 Table 6.5.6 shall be used for concrete to be made with cements meeting strength requirements of "Bangladesh Standard Cement Part-1: Composition, specifications and conformity criteria for common cements" (BDS EN 197-1: 2003), and shall not be applied to concrete containing lightweight aggregates or admixtures other than those for entraining air.

5.6.3.3 Concrete proportioned by water cement ratio limits prescribed in Table 6.5.6 shall also conform to special exposure requirements of Sec 5.5 and to compressive strength test criteria of Sec 5.12.

5.6.4 Average Strength Reduction

As data become available during construction, amount by which value of f'_c must exceed specified value of f'_c may be reduced, provided:

- (a) 30 or more test results are available and the average of test results exceeds that required by Sec 5.6.2.2(a) using a standard deviation calculated in accordance with Sec 5.6.2.1(a), or
- (b) 15 to 29 test results are available and the average of test results exceeds that required by Sec 5.6.2.2(a) using a standard deviation calculated in accordance with Sec 5.6.2.1(b), and provided further that special exposure requirements of Sec 5.5 are met.

Table 6.5.6: Maximum Permissible Water Cement Ratios for Concrete when Strength Data from Field Experience or Trail Mixers are not Available

Specified Compressive Strength*, f'_c N/mm ²	Absolute Water Cement Ratio by Weight	
	Concrete other than air- entrained	Air-entrained concrete
17	0.66	0.54
20	0.60	0.49
25	0.50	0.39
30	0.40	**
35	**	**

* 28 day strength. With most materials, water cement ratios shown will provide average strengths greater than that required in Sec 5.6.2.2.

** For strengths above 30 N/mm² (25 N/mm² for air entrained concrete) concrete proportions shall be established by methods of Sec 5.6.2.

5.7 Preparation of Equipment and Place of Deposit

Preparation before concrete placement shall include the following:

- (a) All equipment for mixing and transporting concrete shall be clean.
- (b) All debris shall be removed from spaces to be occupied by concrete.
- (c) Forms shall be properly cleaned and coated.
- (d) Masonry filler units that will be in contact with concrete shall be soaked thoroughly.
- (e) Reinforcement shall be thoroughly clean of deleterious coatings.
- (f) Water shall be removed from place of deposit before concrete is placed unless a tremie is used or unless otherwise permitted by the engineer.
- (g) All laitance and other unsound material shall be removed before additional concrete is placed against hardened concrete.

5.8 Mixing

5.8.1 All concrete shall be mixed thoroughly until there is a uniform distribution of materials and shall be discharged completely before the mixer is recharged.

5.8.2 Ready mixed concrete shall be mixed and delivered in accordance with the requirements of "Standard Specification for Ready Mixed Concrete" (ASTM C94) or "Standard Specification for Concrete Made by Volumetric Batching and Continuous Mixing" (ASTM C685).

5.8.3 Job mixed concrete shall be mixed in accordance with the following:

- (a) Mixing shall be done in a batch mixer of approved type.
- (b) Mixer shall be rotated at a speed recommended by the manufacturer.
- (c) Mixing shall be continued for at least 90 seconds after all materials are in the drum, unless a shorter time is shown to be satisfactory by the mixing uniformity tests of "Specification for Ready Mixed Concrete" (ASTM C94).
- (d) Materials handling, batching, and mixing shall conform to the applicable provisions of "Specification for Ready Mixed Concrete" (ASTM C94).
- (e) A detailed record shall be kept to identify:
 - (i) number of batches produced;
 - (ii) proportions of materials used;
 - (iii) approximate location of final deposit in structure;
 - (iv) time and date of mixing and placing.

5.9 Conveying

5.9.1 Concrete shall be conveyed from the mixer to the place of final deposit by methods that will prevent segregation or loss of materials.

5.9.2 Conveying equipment shall be capable of providing a supply of concrete to the place of deposit without segregation of ingredients and without interruptions sufficient to permit loss of plasticity between successive increments.

5.10 Depositing

5.10.1 Concrete shall be deposited as near its final position as practical to avoid segregation due to rehandling or flowing.

5.10.2 Concreting shall be carried on at such a rate that concrete is at all times plastic and flows readily into spaces between and around the reinforcement.

5.10.3 Concrete that has partially hardened or been contaminated by foreign materials shall not be deposited in the structure.

5.10.4 Retempered concrete or concrete that has been remixed after initial set shall not be used.

5.10.5 After concreting is started, it shall be carried on as a continuous operation until placing of a panel or section, as defined by its boundaries or predetermined joints, is completed except as permitted or prohibited by Sec 5.16.4.

5.10.6 Top surfaces of vertically formed lifts shall be generally level.

5.10.7 When construction joints are required, joints shall be made in accordance with Sec 5.16.4.

5.10.8 All concrete shall be thoroughly consolidated by suitable means during placement and shall be thoroughly worked around reinforcement and embedded fixtures and into corners of forms.

5.11 Curing

5.11.1 Concrete (other than high early strength) shall be maintained above 10°C and in a moist condition for at least the first 7 days after placement, except when cured in accordance with Sec 5.11.3.

5.11.2 High early strength concrete shall be maintained above 10°C and in a moist condition for at least the first 3 days, except when cured in accordance with Sec 5.11.3.

5.11.3 Accelerated Curing

5.11.3.1 Curing by high pressure steam, steam at atmospheric pressure, heat and moisture or other accepted processes, shall be permitted to accelerate strength gain and reduce time of curing.

5.11.3.2 Accelerated curing shall provide a compressive strength of the concrete at the load stage considered, at least equal to the required design strength at that load stage.

5.11.3.3 Curing process shall be such as to produce concrete with a durability at least equivalent to that obtained for concrete cured by the method of Sec 5.11.1 or 5.11.2.

5.11.4 When required by the engineer, supplementary strength tests in accordance with Sec 5.12.4 shall be performed to assure that curing is satisfactory.

5.12 Evaluation and Acceptance of Concrete

5.12.1 General

5.12.1.1 Concrete shall be proportioned to provide an average compressive strength as prescribed in Sec 5.6.2.2 as well as to satisfy the durability criteria of Sec 5.5. Concrete shall be produced to limit frequency of strengths below f'_c to that prescribed in Sec 5.12.3.3.

5.12.1.2 Requirements of shall be based on tests of cylinders made and tested as prescribed in Sec 5.12.3.

5.12.1.3 Unless otherwise specified, f'_c shall be based on 28 day tests. Test age for f'_c shall be indicated in design drawings or specifications, if it is different from 28 days.

5.12.1.4 Splitting tensile strength tests shall not be used as a basis for field acceptance of concrete.

5.12.2 Frequency of Testing

5.12.2.1 Samples for strength tests of each class of concrete placed each day shall be taken not less than once a day, nor less than once for each 60 m³ of concrete, nor less than once for each 250 m² surface area for slabs or walls.

5.12.2.2 On a given project, if the total volume of concrete is such that frequency of testing required by Sec 5.12.2.1 above would provide less than three strength tests for a given class of concrete, tests shall be made from at least three randomly selected batches or from each batch if three or fewer batches are used.

5.12.2.3 When the total quantity of a given class of concrete is less than 20 m³, strength tests are not required when evidence of satisfactory strength is submitted to and approved by the Engineer.

5.12.2.4 A strength test shall be the average of the strengths of at least two 150 mm by 300 mm cylinders or at least three 100 mm by 200 mm cylinders made from the same sample of concrete and tested at 28 days or at test age designated for determination of f'_c .

5.12.3 Laboratory Cured Specimens

5.12.3.1 Samples for strength tests shall be taken in accordance with "Method of Sampling Freshly Mixed Concrete" (ASTM C172).

5.12.3.2 Cylinders for strength tests shall be moulded and laboratory cured in accordance with "Practice for Making and Curing Concrete Test Specimens in the Field" (ASTM C31/C31M) and tested in accordance with "Test Method for Compressive Strength of Cylindrical Concrete Specimens" (ASTM C39/C39M).

5.12.3.3 Strength level of an individual class of concrete shall be considered satisfactory if both of the following requirements are met :

- (a) Average of three consecutive strength tests (see Sec 5.12.2.4) equals or exceeds f'_c
- (b) No individual strength test (average of two cylinders of 150 mm by 300 mm or average of three cylinders of 100 mm by 200 mm) falls below by more than 3.5 N/mm².

5.12.3.4 If either of the requirements of Sec 5.12.3.3 are not met, steps shall be taken to increase the average of the subsequent strength test results. Requirements of Sec 5.12.5 shall be satisfied if the requirement of Sec 5.12.3.3(b) is not met.

5.12.4 Field Cured Specimens

5.12.4.1 The engineer may require strength tests of cylinders cured under field conditions to check adequacy of curing and protection of concrete in the structure.

5.12.4.2 Field cured cylinders shall be cured under field conditions in accordance with "Practice for Making and Curing Concrete Test Specimens in the Field" (ASTM C31/C31M).

5.12.4.3 Field cured test cylinders shall be moulded at the same time and from the same samples as laboratory cured test cylinders.

5.12.4.4 Procedures for protecting and curing concrete shall be improved when the strength of field cured cylinders at the test age designated for determination of f'_c is less than 85 percent of that of companion laboratory cured cylinders. The 85 percent limitation shall not apply if field cured strength exceeds f'_c by more than 3.5 N/mm².

5.12.5 Investigation of Low Strength Test Results

5.12.5.1 If the result of any strength test (Sec 5.12.2.4) of laboratory cured cylinders falls below the specified value of by more than 3.5 N/mm² (Sec 5.12.3.3(b)) or if tests of field cured cylinders indicate deficiencies in protection and curing (Sec 5.12.4.4), steps shall be taken to assure that the load carrying capacity of the structure is not jeopardized.

5.12.5.2 If the likelihood of low strength concrete is confirmed and computations indicate that load carrying capacity may have been significantly reduced, tests of cores drilled from the area in question may be required in accordance with "Method of Obtaining and Testing Drilled Cores and Sawed Beams of Concrete" (ASTM C42/C42M). In such cases, three cores shall be taken for each strength test more than 3.5 N/mm² below the specified value of f'_c .

5.12.5.3 If concrete in the structure is expected to be dry under service conditions, cores shall be air dried for 7 days before test and shall be tested dry. If concrete in the structure is expected to be more than superficially wet under service conditions, cores shall be immersed in water for at least 40 hours and be tested wet.

5.12.5.4 Concrete in an area represented by core tests shall be considered structurally adequate if the average of three cores is equal to at least 85 percent of f'_c and if no single core is less than 75 percent of f'_c . Additional testing of cores extracted from locations represented by erratic core strength results shall be permitted.

5.12.5.5 If the criteria of Sec 5.12.5.4 above are not met, and if structural adequacy remains in doubt, the responsible authority may order load tests for the questionable portion of the structure, or take other appropriate action.

5.13 Properties of Concrete

5.13.1 Strength

Strength of concrete shall be based on f'_c determined in accordance with the provisions of Sec 5.12.1.

5.13.2 Modulus of Elasticity

5.13.2.1 Modulus of elasticity E_c for stone aggregate concrete may be taken as $44w_c^{1.5}\sqrt{f'_c}$ (N/mm²) for values of w_c between 15 and 25 kN/m³ and f'_c in N/mm². For normal density concrete, E_c may be taken as $4700\sqrt{f'_c}$.

5.13.2.2 Modulus of elasticity E_c for brick aggregate concrete may be taken as $3750\sqrt{f'_c}$.

5.13.3 Creep

The final (30 year) creep strain in concrete ϵ_{cc} shall be predicted from

$$\epsilon_{cc} = \frac{\text{stress}}{E_t} C_c \quad (6.5.3)$$

Where,

E_t is the modulus of elasticity of the concrete at the age of loading t ,

C_c is the creep coefficient.

The creep coefficient may be estimated from Figure 6.5.1. In this Figure, for uniform sections, the effective section thickness is defined as twice the cross-sectional area divided by the exposed perimeter. If drying is prevented by immersion in water or by sealing, the effective section thickness shall be taken as 600 mm.

It can be assumed that about 40%, 60% and 80% of the final creep develops during the first month, 6 months and 30 months under load respectively, when concrete is exposed to conditions of constant relative humidity.

5.13.4 Shrinkage

An estimate of the drying shrinkage of plain concrete may be obtained from Figure 6.5.2. Recommendations for effective section thickness and relative humidity are given in Sec 5.13.3.

Figure 6.5.2 relates to concrete of normal workability made without water reducing admixtures; such concretes shall have an original water content of about 190 litre/m³. Where concrete is known to have a different water content, shrinkage shall be regarded as proportional to water content within the range 150 to 230 litre /m³.

The shrinkage of plain concrete is primarily dependent on the relative humidity of the air surrounding the concrete, the surface area from which moisture can be lost relative to the volume of concrete and on the mix proportion. It is increased slightly by carbonation and self-desiccation and reduced by prolonged curing. An estimate of the shrinkage of symmetrically reinforced concrete sections may be obtained from:

$$\frac{\varepsilon_{sh}}{1+k_{\rho}} \quad (6.5.4)$$

Where,

ε_{sh} is the shrinkage of the plain concrete;

ρ is the area of steel relative to that of the concrete;

k_{ρ} is a coefficient, taken as 25 for internal exposure and as 15 for external exposure.

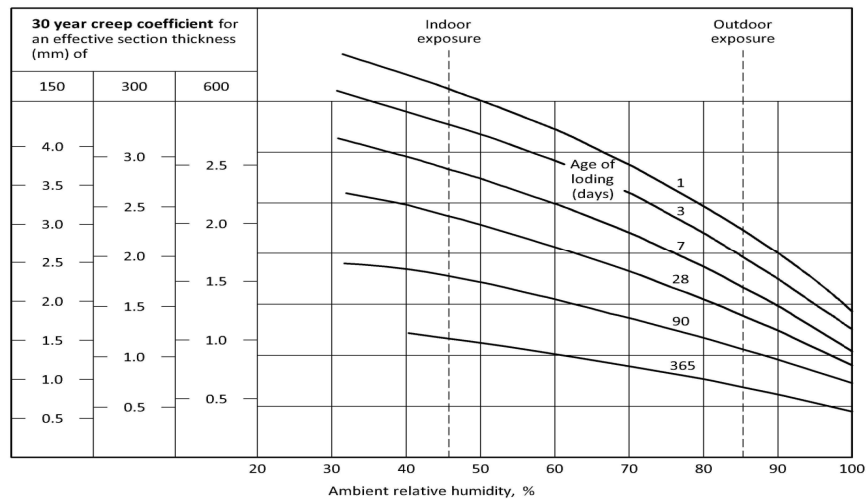


Figure 6.5.1 Effects of relative humidity, age of loading and section thickness upon creep factor

5.13.5 Thermal Strains

Thermal strains shall be calculated from the product of a suitable coefficient of thermal expansion and a temperature change. The temperature change can be determined from the expected service conditions and climatic data. Externally exposed concrete does not respond immediately to air temperature change, and climatic temperature ranges may require adjustment before use in movement calculations.

The coefficient of thermal expansion of concrete is dependent mainly on the expansion coefficients for the aggregate and the cement paste, and the degree of saturation of the concrete. The thermal expansion of aggregate is related to mineralogical composition (See Table 6.5.7)

Cement paste has a coefficient of thermal expansion that is a function of moisture content, and this affects the concrete expansion as shown in Fig 6.5.3. It may be seen that partially dry concrete has a coefficient of thermal expansion that is approximately $2 \times 10^{-6}/^{\circ}\text{C}$ greater than the coefficient for saturated concrete.

5.14 Concreting in Adverse Weather

5.14.1 Concreting shall be avoided during periods of near freezing weather.

5.14.2 During hot weather, proper attention shall be given to ingredients, production methods, handling, placing, protection, and curing to prevent excessive concrete temperatures or water evaporation that could impair required strength or serviceability of the member or structure.

5.14.3 During rainy weather, proper protection shall be given to ingredients, production methods, handling and placing of concrete. If required in the opinion of the engineer, the concreting operation shall be postponed and newly placed concrete shall be protected from rain after forming proper construction joint for future continuation.

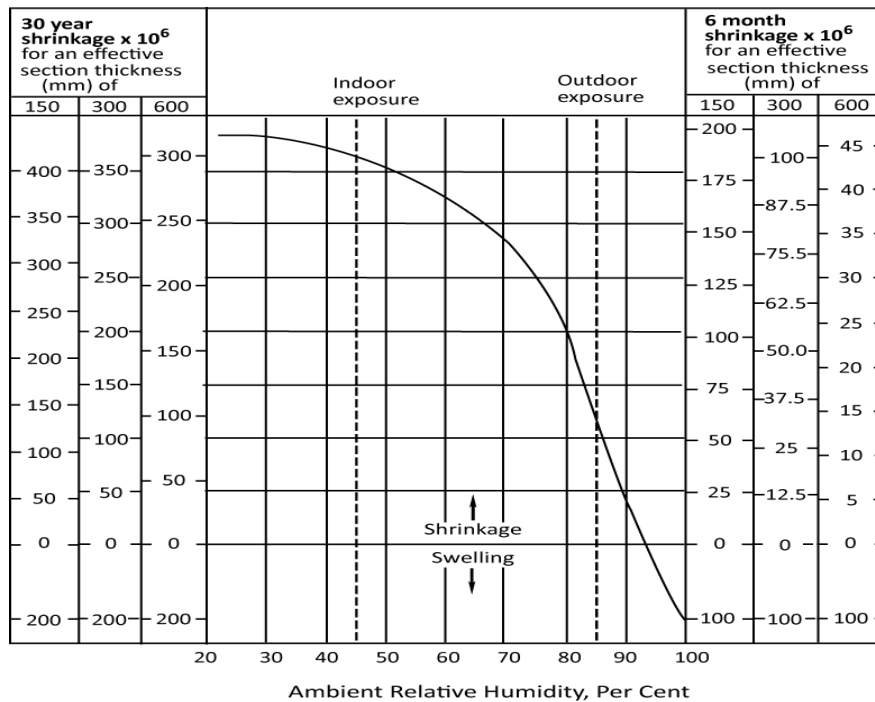
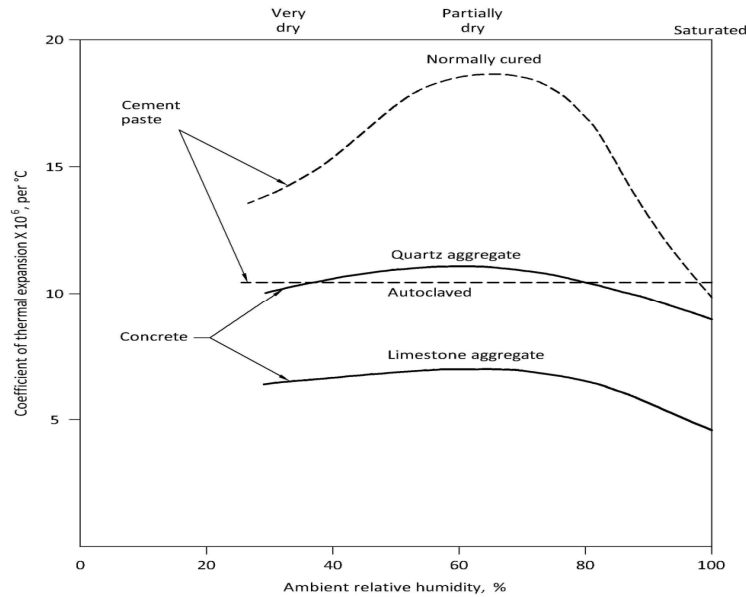


Figure 6.5.2 Drying shrinkage of normal-weight concrete

Table 6.5.7: Thermal Expansion of Rock Group and Related Concrete

Aggregate Type	Typical Coefficient of Expansion ($1 \times 10^{-6}/^{\circ}\text{C}$)	
	Aggregate	Concrete
Flint, quartzite	11	12
Granite, basalt	7	10
Limestone	6	8

**Figure 6.5.3 Effect of dryness upon the coefficient of thermal expansion of hardened cement and concrete**

5.15 Surface Finish

5.15.1 Type of Finish

A wide variety of finishes can be produced. Surface cast against forms may be left as cast, e.g. plain or profiled, the initial surface may be removed, e.g. by tooling or sandblasting, or the concrete may be covered, e.g. by paint or tiles; combinations of these techniques may also be adopted, e.g. a ribbed profile with bush hammered ribs. Upper surfaces not cast against forms may be trowelled smooth or profiled, e.g. by tamping; the initial surface may be removed, e.g. by spraying, or it may be covered, e.g. by a screed or plastic floor finish. When selecting the type of finish, consideration shall be given to the ease of producing a finish of the required

standard, the viewing distance and the change of appearance with time. In the case of external surfaces, account shall be taken of the weather pattern at the particular location, any impurities in the air and the effect of the shape of the structure upon the flow of water across its surface. Such considerations will often preclude the specification of surfaces of uniform colour as these are very difficult to produce and deteriorate with time, particularly if exposed to the weather.

5.15.2 Quality of Finish

A high quality finish is one that is visually pleasing; it may include colour variations and physical discontinuities but these are likely to be distributed systematically or randomly over the whole surface rather than being concentrated in particular areas. When deciding on the quality of finish to be specified, consideration should be given to the viewing distance and the exposure conditions.

There is no method whereby the quality of finish that will be accepted can unequivocally be defined. To achieve the quality required calls for good communication between experienced personnel conversant with the production of finishes and close collaboration with the site. The quality of finish can be identified in the following very broad terms:

- (a) Class 2 applies to surfaces that are to be exposed to view but where appearance is not critical; such surfaces might be the walls of fire escape stairs or plant rooms and columns and beams of structures that are normally viewed in the shade, e.g. car parks and warehouses;
- (b) Class 1 is appropriate to most surfaces exposed to view including the external walls of industrial, commercial and domestic buildings;
- (c) Special class is appropriate to the highest standards of appearance, such as might be found in prestigious buildings, where it is possible to justify the high cost of their production.
- (d) These broad descriptions may be amplified by written descriptions of the method of finish, by photographs, by samples or by reference to existing structures.

5.15.3 Type of Surface Finish

Smooth off-the-form and board marked finishes are not recommended for external use, but where they are specified for interior use the following types may be quoted for the guidance of both designers and contractor. Designers should appreciate that it is virtually impossible to achieve dense, flat, smooth, even coloured blemish free concrete surfaces directly from the form work. Some degree of making good is inevitable, even with precast work.

- (a) Type A finish: This finish is obtained by the use of properly designed formwork or moulds of timber, plywood, plastics, concrete or steel. Small blemishes caused by entrapped air or water may be expected, but the surface should be free from voids, honeycombing or other blemishes.

- (b) Type B finish: This finish can only be obtained by the use of high quality concrete and formwork. The concrete shall be thoroughly compacted and all surfaces shall be true, with clean arises. Only very minor surface blemishes shall occur, with no staining or discoloration from the release agent.
- (c) Type C finish: This finish is obtained by first producing a type B finish. The surface is then improved by carefully removing all fins and other projections, thoroughly washing down, and then filling the most noticeable surface blemishes with a cement and fine aggregate paste to match the colour of the original concrete. The release agent should be carefully chosen to ensure that the concrete surface will not be stained or discoloured. After the concrete has been properly cured, the face shall be rubbed down, where necessary, to produce a smooth and even surface.

5.15.4 Production

The quality of a surface depends on the constituents and proportions of the concrete mix, the efficiency of mixing, the handling and compaction of the concrete and its curing. The characteristics of the formwork and the release agent may also be of critical importance. Requirements may be stated for any aspect of production that might contribute towards the achievement of the required type of quality of finish.

5.15.5 Inspection and Making Good

The surface of the concrete shall be inspected for defects and for conformity with the specification and, where appropriate, for comparison with approved sample finishes. Subject to the strength and durability of the concrete being unimpaired, the making good of surface defects may be permitted but the standard of acceptance shall be appropriate to the type and quality of the finish specified and ensure satisfactory performance and durability. On permanently exposed surfaces great care is essential in selecting the materials and the mix proportions to ensure that the final colour of the faced area blends with the parent concrete in the finished structure.

Voids can be filled with fine mortar, preferably incorporating styrene butadiene rubber (SBR) or polyvinyl acetate (PVA), while the concrete is still green or when it has hardened. Fine cracks can be filled by wiping a cement grout, an SBR, PVA or latex emulsion, a cement/SBR or a cement/PVA slurry across them. Fins and other projections shall be rubbed down.

5.15.6 Protection

High quality surface finishes are susceptible to damage during subsequent construction operations and temporary protection may have to be provided in vulnerable areas. Examples of such protective measures include the strapping of laths to arrises and the prevention of rust being carried from exposed starter bars to finished surfaces.

5.16 Formwork**5.16.1 Design of Formwork**

5.16.1.1 Forms shall result in a final structure that conforms to shapes, lines, and dimensions of the members as required by the design drawings and specifications.

5.16.1.2 Forms shall be substantial and sufficiently tight to prevent leakage of mortar.

5.16.1.3 Forms shall be properly braced or tied together to maintain position and shape.

5.16.1.4 Forms and their supports shall be designed so as not to damage previously placed structure.

5.16.1.5 Design of formwork shall include consideration of the following factors:

- (a) Rate and method of placing concrete;
- (b) Construction loads, including vertical, horizontal and impact loads;
- (c) Special form requirements for construction of shells, folded plates, domes, architectural concrete, or similar types of elements.

5.16.1.6 Forms for prestressed concrete members shall be designed and constructed to permit movement of the member without damage during application of prestressing force.

5.16.2 Removal of Forms and Shores

5.16.2.1 No construction loads shall be supported on, nor any shoring removed from, any part of the structure under construction except when that portion of the structure in combination with remaining forming and shoring system has sufficient strength to support safely its weight and loads placed thereon.

5.16.2.2 Sufficient strength shall be demonstrated by structural analysis considering proposed loads, strength of forming and shoring system, and concrete strength data. Structural analysis and concrete strength test data shall be furnished to the engineer when so required.

5.16.2.3 No construction loads exceeding the combinations of superimposed dead load plus specified live load shall be supported on any unshored portion of the structure under construction, unless analysis indicates adequate strength to support such additional loads.

5.16.2.4 Forms shall be removed in such a manner as not to impair safety and serviceability of the structure. All concrete to be exposed by form removal shall have sufficient strength not to be damaged thereby.

5.16.2.5 Forms supporting prestressed concrete members shall not be removed until sufficient prestressing has been applied to enable prestressed members to carry their dead load and anticipated construction loads.

5.16.3 Conduits and Pipes Embedded in Concrete

5.16.3.1 Conduits, pipes and sleeves of any materials not harmful to concrete and within the limitations specified herein shall be permitted to be embedded in concrete with the approval of the engineer, provided they are not considered to replace structurally the displaced concrete.

5.16.3.2 Conduits and pipes of aluminium shall not be embedded in structural concrete unless effectively coated or covered to prevent aluminium concrete reaction or electrolytic action between aluminium and steel.

5.16.3.3 Conduits, pipes, and sleeves passing through a slab, wall, or beam shall not impair significantly the strength of the construction.

5.16.3.4 Conduits and pipes, with their fittings, embedded within a column shall not displace more than 4 percent of the area of cross-section on which strength is calculated or which is required for fire protection.

5.16.3.5 Except when drawings for conduits and pipes are approved by the engineer, conduits and pipes embedded within a slab, wall or beam (other than those merely passing through) shall satisfy the following:

- (a) They shall not be larger in outside dimension than one third (1/3) the overall thickness of slab, wall, or beam in which they are embedded.
- (b) They shall not be spaced closer than 3 diameters or widths on centre.
- (c) They shall not impair significantly the strength of the construction.

5.16.3.6 Conduits, pipes and sleeves shall be permitted to be considered as replacing structurally in compression the displaced concrete provided :

- (a) They are not exposed to rusting or other deterioration.
- (b) They have nominal inside diameter not over 50 mm and are spaced not less than 3 diameters on centres.

5.16.3.7 Pipes and fittings shall be designed to resist effects of the material, pressure, and temperature to which they will be subjected.

5.16.3.8 No liquid, gas, or vapour, except water not exceeding 30°C nor 0.3 N/mm² pressure, shall be placed in the pipes until the concrete has attained its design strength.

5.16.3.9 In solid slabs, piping, unless it is for radiant heating, shall be placed between the top and bottom reinforcements.

5.16.3.10 Concrete cover for pipes, conduits, and fittings shall be not less than 40 mm for concrete exposed to earth or weather, nor 20 mm for concrete not exposed to weather or in contact with ground.

5.16.3.11 Reinforcement with an area not less than 0.002 times the area of concrete section shall be provided normal to piping.

5.16.3.12 Piping and conduit shall be so fabricated and installed that cutting, bending, or displacement of reinforcement will not be required.

5.16.4 Construction Joints

5.16.4.1 Surface of concrete construction joints shall be cleaned and laitance removed.

5.16.4.2 Immediately before new concrete is placed, all construction joints shall be wetted and standing water removed.

5.16.4.3 Construction joints shall be so made and located as not to impair the strength of the structure. Provision shall be made for transfer of shear and other forces through construction joints. See Sec 6.4.5.9.

5.16.4.4 Construction joints in floors shall be located within the middle third of spans of slabs, beams and girders. Joints in girders shall be offset a minimum distance of two times the width of intersecting beams.

5.16.4.5 Beams, girders, or slabs supported by columns or walls shall not be cast or erected until concrete in the columns or walls is no longer plastic.

5.16.4.6 Beams, girders, haunches, drop panels and capitals shall be placed monolithically as part of a slab system unless otherwise shown in the design drawings or specifications.

5.17 Shotcrete

5.17.1 General

Shotcrete shall be defined as mortar or concrete pneumatically projected at high velocity onto a surface. Except as specified in this Section, shotcrete shall conform to the provisions of this Code regarding plain concrete or reinforced concrete.

5.17.2 Proportions and Materials

Shotcrete proportions shall be such that suitable placement is ensured using the delivery equipment selected, and shall result in finished in place hardened shotcrete meeting the strength requirements of Chapter 6.

5.17.3 Aggregate

Coarse aggregate, if used, shall not exceed 20 mm in size.

5.17.4 Reinforcement

The maximum size of reinforcement shall be 16 mm \emptyset bars unless it can be demonstrated by preconstruction tests that adequate embedment of larger bars can be achieved. When 16 mm \emptyset or smaller bars are used, there shall be a minimum clearance of 60 mm between parallel reinforcing bars. When bars larger than 16 mm \emptyset are permitted, there shall be a minimum clearance between parallel bars equal to six diameters of the bars used. When two curtains of steel are provided, the curtain nearest the nozzle shall have a spacing equal to 12 bar diameters and the remaining curtain shall have a minimum spacing of 6 bar diameters.

Lap splices in reinforcing bars shall be by the noncontact lap splice method with at least 50 mm clearance between bars. The engineer may permit the use of contact lap splices when necessary for the support of the reinforcement, provided it can be demonstrated by means of preconstruction testing that adequate embedment of the bars at the splice can be achieved and provided further that the splices are placed so that the plane containing the centres of the two spliced bars is perpendicular to the surface of the shotcrete work. Shotcrete shall not be applied to spirally tied columns.

5.17.5 Preconstruction Tests

When required by the engineer a test panel shall be shot, cured, cored or sawn, examined and tested prior to commencement of the project. The sample panel shall be representative of the project and simulate job conditions as closely as possible. The panel thickness and reinforcing shall reproduce the thickest and the most congested area specified in the structural design. It shall be shot at the same angle, from a similar distance, using the same nozzleman and with the same concrete mix design that will be used on the project.

5.17.6 Rebound

Any rebound or accumulated loose aggregate shall be removed from the surfaces to be covered prior to placing the initial or any succeeding layers of shotcrete. Rebound shall not be reused as aggregate.

5.17.7 Joints

Except where permitted, unfinished work shall not be allowed to stand for more than 30 minutes unless all edges are sloped thin. Before placing additional material adjacent to previously applied work, sloping and square edges shall be cleaned and wetted.

5.17.8 Damage

An in-place shotcrete which exhibits sags or sloughs, segregation, honeycombing, sand pockets or other obvious defects shall be removed and replaced.

5.17.9 Curing

During the curing periods, shotcrete shall be maintained above 5° C and in moist condition. In initial curing, shotcrete shall be kept continuously moist for 24 hours after placement is complete. Final curing shall continue for seven days after shotcreting, for three days if high early strength cement is used, or until the specified strength is obtained. Final curing shall consist of a fog spray or an approved moisture retaining cover or membrane. In sections of a depth in excess of 300 mm, final curing shall be the same as that for initial curing.

5.17.10 Strength Test

Strength test for shotcrete shall be made by an approved agency on three representative specimens of Core or Cube that have been water soaked for at least 24 hours prior to testing. When the maximum size of aggregate is larger than 10 mm, core specimens shall not be less than 75 mm in diameter or the size of cube specimen shall not be less than 75 mm. When the maximum size of aggregate is 10 mm or smaller, core specimens shall not be less than 50 mm in diameter or the size of cube specimen shall not be less than 50 mm. Specimens shall be taken in accordance with one of the following provisions:

- (a) From work: taken at least one from each shift but not less than one for each 20 m³ of shotcrete;
- (b) From test panels: taken not less than once each shift nor less than one for each 20 m³ of shotcrete placed. When the maximum size aggregate is larger than 10 mm, the test panels shall have a minimum dimension of 450 mm by 450 mm. When the maximum size aggregate is 10 mm or smaller, the test panels shall have a minimum dimension of 300 mm by 300 mm. Panels shall be gunned in the same position as the work, during the course of the work and by the same nozzle men doing the work. The condition under which the panels are cured shall be the same as the work.

The average strength of three cores from a single panel shall be equal to or exceed $0.85 f'_c$ with no single core less than $0.75 f'_c$. The average strength of three cubes taken from a single panel must equal or exceed f'_c with no individual cube less than f'_c . To check testing accuracy, locations represented by erratic core strengths may be retested.

5.17.11 Inspections

5.17.11.1 Inspection during placement

When shotcrete is used for columns and beams, a special inspector is required. The special inspector shall provide continuous inspection to the placement of the reinforcement and shotcreting and shall submit a statement indicating compliance with the plans and specifications.

5.17.11.2 Visual examination for structural soundness of in-place shotcrete

Completed shotcrete work shall be checked visually for reinforcing bar embedment, voids, rock pocket, sand streaks and similar deficiencies by examining a minimum of three 75 mm cores taken from three areas chosen by the engineer which represent the worst congestion of reinforcing bars occurring in the project. Extra reinforcing bars may be added to non-congested areas and cores may be taken from these areas. The cores shall be examined by the special inspector and a report submitted to the engineer prior to final approval of the shotcrete.

5.17.12 Equipment

The equipment used in construction testing shall be the same equipment used in the work requiring such testing unless substitute equipment is approved by the Engineer.

PART VI**Chapter 6****Strength Design Of Reinforced Concrete Structures****6.1 Analysis and Design - General Considerations****6.1.1 Definitions**

The following terms are defined for general use in this Code. Specialized definitions appear in individual chapters.

COLUMN	Member with a ratio of height- to least lateral dimension exceeding 3 used primarily to support axial compression load. For a tapered member the least lateral dimension is the average of the top and bottom dimensions of the smaller side.
COMPRESSION CONTROLLED SECTIONS	A cross section in which the net tensile strain in the extreme tension steel at nominal strength is less than or equal to the compression-controlled strain limit.
COMPRESSION CONTROLLED STRAIN LIMIT	The net tensile strain at balanced strain condition. See Sec 6.3.3.3.
CONCRETE	Mixture of Portland cement or any other hydraulic cement, fine aggregate, coarse aggregate and water with or without admixture.
CONCRETE, LIGHTWEIGHT	Concrete containing lightweight aggregate and an equilibrium density as determined by ASTM C567, between 1450 - 1850 kg/m ³ .
CONCRETE, NORMALWEIGHT	Concrete containing only aggregate that conforms to ASTM C33.
CONCRETE, SPECIFIED COMPRESSIVE STRENGTH OF f'_c	Compressive strength of concrete used in design and evaluated in accordance with provisions of Sec 5.12, expressed in N/mm ² .
CONNECTION	A region that joins two or more members.
CONTRACTION JOINT	Formed, sawed, or tooled groove in a concrete structure to create a weakened plane and regulate the location of cracking resulting from the dimensional change of different parts of the structure.

COVER, SPECIFIED CONCRETE	The distance between the outermost surface of embedded reinforcement and the closest outer surface of the concrete indicated on design drawing or in project specification.
DESIGN DISPLACEMENT	The total lateral displacement expected for the design-basis earthquake, as required by provisions of the Code for earthquake resistant design.
DESIGN LOAD COMBINATION	Combination of factored loads and forces. See Sec 2.7.
DESIGN STORY DRIFT RATIO	Relative difference of design displacement between top and bottom of a story divided by the story height.
DEVELOPMENT LENGTH	Length of embedded reinforcement, required to develop the design strength of reinforcement at a critical section. See Sec 8.2.
DROP PANEL	A projection below the slab used to reduce the amount of negative reinforcement over a column or the minimum required slab thickness, and to increase the slab shear strength. See Sec 6.5.
EFFECTIVE DEPTH OF SECTION	Distance measured from extreme compression fibre to centroid of longitudinal tension reinforcement.
EMBEDMENT LENGTH	Length of embedded reinforcement provided beyond a critical section.
EQUILIBRIUM DENSITY	Density of lightweight concrete after exposure to a relative humidity 50 ± 5 percent and temperature of $73.5 \pm 3.5^{\circ}$ F for a period of time sufficient to reach constant density (see ASTM C567)
EXTREME TENSION STEEL	The reinforcement that is the farthest from the extreme compression fibre.
ISOLATION JOINT	A separation between adjoining parts of a concrete structure, usually a vertical plane, at a designed location such as to interfere least with performance of the structure, yet such as to allow relative movement in three directions and avoid formation of cracks elsewhere in the concrete and through which all or part of the bonded reinforcement is interrupted.

JOINT	Portion of structure common to intersecting members. The effective cross sectional area of a joint of a special moment frame, A_j for shear strength computation is defined in Sec 8.3.7.3.
LICENSED DESIGN PROFESSIONAL	An individual who is licensed to practice structural design as defined by the statutory requirements of the professional licensing laws of the state or jurisdiction in which the project is to be constructed and who is in responsible charge of the structural design.
LOAD, FACTORED	Load, multiplied by appropriate factor, used to proportion members by strength design method of this Code.
MODULUS OF ELASTICITY	Ratio of normal stress to corresponding strain for tensile or compressive stresses below proportional limit of material.
PEDESTAL	Member with a ratio of height- to-least lateral dimension less than or equal to 3 used primarily to support axial compression load. For a tapered member the least lateral dimension is the average of the top and bottom dimensions of the smaller side.
PLAIN CONCRETE	Structural concrete with no reinforcement or with less reinforcement than the minimum amount specified for reinforced concrete.
PLASTIC HINGE REGION	Length of frame element over which flexural yielding is intended to occur due to earthquake design displacement, extending not less than a distance h from the critical section where flexural yielding occurs.
PRECAST CONCRETE	Structural concrete element cast elsewhere than its final position in the structure.
REINFORCED CONCRETE	Structural concrete reinforced with no less than the minimum amount of reinforcement specified in the Code.
SEISMIC HOOK	A hook on a stirrup, or cross tie having a bend not less than 135° , except that circular hoops shall have a bend not less than 90° . Hooks shall have a $6d_b$ (but not less than 75 mm) extension that engages the longitudinal reinforcement and projects into the interior of the stirrup or hoop.

SPIRAL REINFORCEMENT	Continuously wound reinforcement in the form of a cylindrical helix.
SPLITTING TENSILE STRENGTH (f_{ct})	Tensile strength of concrete determined in accordance with ASTM C496 as described in ASTM C330.
STIRRUPS	Reinforcement used to resist shear and torsion stresses in a structural member, typically bars, wires, or welded wire reinforcements either single leg or bent into L, U, or rectangular shapes and located perpendicular to or at an angle to longitudinal reinforcement. (The term “stirrups” is usually used to lateral reinforcement in flexural members and the term “ties” to those in compression members.
STRENGTH DESIGN	Nominal strength multiplied by a strength reduction factor ϕ .
STRENGTH, NOMINAL	Strength of a member or cross section calculated in accordance with provisions and assumptions of the strength design method of this Code before application of any strength reduction factor.
STRENGTH, REQUIRED	Strength of a member or cross section required to resist factored loads or related internal moments and forces in such combination as are stipulated in this Code.
STRUCTURAL CONCRETE	All concrete used for structural purpose including plain and reinforced concrete.
TENSION CONTROLLED SECTION	A cross section in which the net tensile strain in the extreme tensile steel at nominal strength is greater than or equal to 0.005.
TIE	Loop of reinforcing bar or wire enclosing longitudinal reinforcement. A continuously wound bar or wire in the form of a circle, rectangle or other polygon shape without re-entrant corner is acceptable.
YIELD STRENGTH	Specified minimum yield strength or yield point of reinforcement. Yield strength or yield point shall be determined in tension according to applicable ASTM standards.

6.1.2 Notation and Symbols

Unless otherwise explicitly stated, the following units shall be implicit for the corresponding quantities in the design and other expressions provided in this Chapter:

Lengths	mm
Areas	mm ²
Second moments of area	mm ⁴
Force (axial, shear)	N
Moment, torsion	N-mm
Stress, strength	MPa, N/mm ²

The following notation apply to Chapters 6 and 8, and Appendices A, I, J, K and L of this Part.

- a = Depth of equivalent rectangular stress block as defined in Sec 6.3.2.7.1; (mm)
- a_v = Shear span, equal to distance from center of concentrated load to either: (a) face of support for continuous or cantilevered members, or (b) center of support for simply supported members, mm, Sec 6.4 and Appendix I
- A_b = Area of an individual bar or wire, mm², Sec 8.2
- A_{brg} = Net bearing area of the head of stud, anchor bolt, or headed deformed bar, mm², Sections 8.2.17 and K.5.3
- A_c = Cross-sectional area of concrete section resisting shear transfer, mm², Sec 6.4.5.5
- A_{ch} = Cross-sectional area of a structural member measured to the outside edges of transverse reinforcement, mm², Sections 6.3.9, 8.3.5.4
- A_{cp} = Area enclosed by outside perimeter of concrete cross section, mm², see Sections 6.4.4 and 8.3.8.3
- A_{cs} = Cross-sectional area at one end of a strut in a strut-and-tie model, taken perpendicular to the axis of the strut, mm², Sec I.3.1 Appendix I.
- A_{cv} = Gross area of concrete section bounded by web thickness and length of section in the direction of shear force considered, mm², Sec 8.3.6.2
- A_{cw} = Area of concrete section of an individual pier, horizontal wall segment, or coupling beam resisting shear, mm², Sec 8.3.6

- A_f = Area of reinforcement in bracket or corbel resisting factored moment, mm^2 , see Sec 6.4.7
- A_g = Gross area of concrete section, mm^2 For a hollow section, A_g is the area of the concrete only and does not include the area of the void(s), see Sections 6.2, 6.3, 6.4, 6.6, 6.7, 6.10, 8.3.5
- A_h = Total area of shear reinforcement parallel to primary tension reinforcement in a corbel or bracket, mm^2 , see Sec 6.4.7
- A_j = Effective cross-sectional area within a joint in a plane parallel to plane of reinforcement generating shear in the joint, mm^2 , see Sec 8.3.7
- A_l = Total area of longitudinal reinforcement to resist torsion, mm^2 , Sec 6.4
- $A_{l,min}$ = Minimum area of longitudinal reinforcement to resist torsion, mm^2 , see Sec 6.4.4.5.3
- A_n = Area of reinforcement in bracket or corbel resisting tensile force N_{uc} , mm^2 , see Sec 6.4.7
- A_{nz} = Area of a face of a nodal zone or a section through a nodal zone, mm^2 , Sec I.5 Appendix I
- A_{Nc} = Projected concrete failure area of a single anchor or group of anchors, for calculation of strength in tension, mm^2 , see Sec K5.2.1, Appendix K
- A_{Nco} = Projected concrete failure area of a single anchor, for calculation of strength in tension if not limited by edge distance or spacing, mm^2 , see Sec K5.2.1, Appendix K
- A_o = Gross area enclosed by shear flow path, mm^2 , Sec 6.4
- A_{oh} = Area enclosed by centerline of outermost closed transverse torsional reinforcement, mm^2 , Sec 6.4
- A_s = Area of nonprestressed longitudinal tension reinforcement, mm^2 , Sections 6.3, 6.4, 6.6, 6.8,
- A_{s1} = Area of tension reinforcement corresponding to moment of resistance M_{n1} , see Sec 6.3.15.1(b)
- A_{s2} = Area of additional tension steel, see Sec 6.3.15.1(b)
- A'_s = Area of compression reinforcement, mm^2 , Sec I.3.5 Appendix I

- A_{sc} = Area of primary tension reinforcement in a corbel or bracket, mm^2 , see Sec 6.4.7.3.5
- $A_{se,N}$ = Effective cross-sectional area of anchor in tension, mm^2 , Sec K.5.1 Appendix K
- $A_{se,V}$ = Effective cross-sectional area of anchor in shear, mm^2 , Sec K. 6.1 Appendix K
- A_{sf} = Area of reinforcement required to balance the longitudinal compressive force in the overhanging portion of the flange of a T-beam, see Sec 6.3.15.2(b)
- A_{sh} = Total cross-sectional area of transverse reinforcement (including crossties) within spacing s and perpendicular to dimension h_c , mm^2 , Sec 8.3.5
- A_{si} = Total area of surface reinforcement at spacing s_i in the i -th layer crossing a strut, with reinforcement at an angle α_i to the axis of the strut, mm^2 , Sec I.3.3 Appendix I
- $A_{s,min}$ = Minimum area of flexural reinforcement, mm^2 , see Sec 6.3.5
- A_{st} = Total area of nonprestressed longitudinal reinforcement (bars or steel shapes), mm^2 , Sec 6.3.3
- A_{sx} = Area of structural steel shape, pipe, or tubing in a composite section, mm^2 , Sec 6.3
- A_t = Area of one leg of a closed stirrup resisting torsion within spacing s , mm^2 , Sec 6.4
- A_{tr} = Total cross-sectional area of all transverse reinforcement within spacing s that crosses the potential plane of splitting through the reinforcement being developed, mm^2 , Sec 8.2.3
- A_{ts} = Area of nonprestressed reinforcement in a tie, mm^2 , Sec I.4.1 Appendix I
- A_v = Area of shear reinforcement spacing s , mm^2 , Sections 6.4, 6.12
- A_{Vc} = Projected concrete failure area of a single anchor or group of anchors, for calculation of strength in shear, mm^2 , see Sec K6.2.1 Appendix K
- A_{Vco} = Projected concrete failure area of a single anchor, for calculation of strength in shear, if not limited by corner influences, spacing, or member thickness, mm^2 , see Sec K6.2.1 Appendix K

- A_{vd} = Total area of reinforcement in each group of diagonal bars in a diagonally reinforced coupling beam, mm², Sec 8.3.6
- A_{vf} = Area of shear-friction reinforcement, mm², Sec 6.4.5
- A_{vh} = Area of shear reinforcement parallel to flexural tension reinforcement within spacing s_2 , mm², Sec 6.4
- $A_{v,min}$ = Minimum area of shear reinforcement within spacing s , mm², see Sec 6.4.3.5
- A_1 = Loaded area, mm², Sec 6.3
- A_2 = Area of the lower base of the largest frustum of a pyramid, cone, or tapered wedge contained wholly within the support and having for its upper base the loaded area, and having side slopes of 1 vertical to 2 horizontal, mm², Sec 6.3
- b = Width of compression face of member, mm, Sec 6.3
- b_o = Perimeter of critical section for shear in slabs and footings, mm, see Sec 6.4.10.1.2
- b_s = Width of strut, mm, Sec I.3.3 Appendix I
- b_t = Width of that part of cross section containing the closed stirrups resisting torsion, mm, Sec 6.4
- b_v = Width of cross section at contact surface being investigated for horizontal shear, mm, Sec 6.12
- b_w = Web width, or diameter of circular section, mm, Sections 6.3, 6.4, 8.2, 8.3.4
- b_1 = Dimension of the critical section b_o measured in the direction of the span for which moments are determined, mm, Sec 6.5
- b_2 = Dimension of the critical section b_o measured in the direction perpendicular to b_1 , mm, Sec 6.5
- c = Distance from extreme compression fiber to neutral axis, mm, Sections 6.2, 6.3, 6.6, 8.3.6
- C_a, C_b = Moment coefficients, Sec 6.5.8
- c_{ac} = Critical edge distance required to develop the basic concrete breakout strength of a post- installed anchor in uncracked concrete without supplementary reinforcement to control splitting, mm, see Sec K8.6 Appendix K

- $c_{a,max}$ = Maximum distance from center of anchor shaft to the edge of concrete, mm, Sec K.5.2.3 Appendix K
- $c_{a,min}$ = Minimum distance from center of anchor shaft to the edge of concrete, mm, Sec K.8.6 Appendix K
- c_{a1} = Distance from the center of an anchor shaft to the edge of concrete in one direction, mm. If shear is applied to anchor, c_{a1} is taken in the direction of the applied shear. If tension is applied to the anchor, c_{a1} is the minimum edge distance, Sec K.5.2 Appendix K
- c_{a2} = Distance from center of an anchor shaft to the edge of concrete in the direction perpendicular to c_{a1} , mm, Sec K.5.4 Appendix K
- c_b = Smaller of: (a) the distance from center of a bar or wire to nearest concrete surface, and (b) one-half the center-to-center spacing of bars or wires being developed, mm, Sec 8.2.3
- c_c = Clear cover of reinforcement, mm, see Sec 6.3.6.4
- c_1 = Dimension of rectangular or equivalent rectangular column, capital, or bracket measured in the direction of the span for which moments are being determined, mm, Sections 6.4, 6.5, 8.3.4
- c_2 = Dimension of rectangular or equivalent rectangular column, capital, or bracket measured in the direction perpendicular to c_1 , mm, Sec 6.5
- C = Cross-sectional constant to define torsional properties of slab and beam, see Sec 6.5.6.4.2
- C_m = Factor relating actual moment diagram to an equivalent uniform moment diagram, Sec 6.3
- d = Distance from extreme compression fiber to centroid of longitudinal tension reinforcement, mm, Sections 6.2, 6.3, 6.4, 6.6, 6.12, 8.1.5, 8.2.7, 8.3.4
- d' = Distance from extreme compression fiber to centroid of longitudinal compression reinforcement, mm, Sec 6.2
- d_a = Outside diameter of anchor or shaft diameter of headed stud, headed bolt, or hooked bolt, mm, see Sec K.8.4, Appendix K
- d'_a = Value substituted for d_a when an oversized anchor is used, mm, see Sec K.8.4, Appendix K

- d_{pile} = Diameter of pile at footing base, mm, Sec 6.8
- d_t = Distance from extreme compression fiber to centroid of extreme layer of longitudinal tension steel, mm, Sections 6.2, 6.3
- D = Dead loads, or related internal moments and forces, Sections 6.1, 6.2, 6.11
- e_h = Distance from the inner surface of the shaft of a J- or L-bolt to the outer tip of the J- or L-bolt, mm, Sec K.5.3 Appendix K
- e'_N = Distance between resultant tension load on a group of anchors loaded in tension and the Centroid of the group of anchors loaded in tension, mm; e'_N is always positive, Sec K.5.2 Appendix K
- e'_V = Distance between resultant shear load on a group of anchors loaded in shear in the same direction, and the centroid of the group of anchors loaded in shear in the same direction, mm; e'_V is always positive, Sec K.6.2 Appendix K
- E = Load effects of earthquake, or related internal moments and forces, Sections 6.2, 8.3.6
- E_c = Modulus of elasticity of concrete, MPa see Sec 6.1.7.1, 6.2, 6.3, 6.6, 6.9
- E_{cb} = Modulus of elasticity of beam concrete, MPa, Sec 6.5
- E_{cs} = Modulus of elasticity of slab concrete, MPa, Sec 6.5
- EI = Flexural stiffness of compression member, N·mm², see Sec 6.3.10.6
- E_s = Modulus of elasticity of reinforcement and structural steel, MPa, see Sections 6.1.7.2, 6.3, 6.6
- f'_c = Specified compressive strength of concrete, MPa, Sections 6.1 to 6.4, 6.6, 6.9, 8.2, 8.3, Appendices I, K
- f_{ce} = Effective compressive strength of the concrete in a strut or a nodal zone, MPa, Sec 6.8.5, I.3.1 Appendix I
- f_{ct} = Average splitting tensile strength of lightweight concrete, MPa, See Sec 6.1.8.1 Sections 6.1, 6.4, 8.2.3.4
- f_d = Stress due to unfactored dead load, at extreme fiber of section where tensile stress is caused by externally applied loads, MPa, Sec 6.4

- f_{pc} = Compressive stress in concrete at centroid of cross section resisting externally applied loads or at junction of web and flange when the centroid lies within the flange, MPa. (In a composite member, f_{pc} is the resultant compressive stress at centroid of composite section, or at junction of web and flange when the centroid lies within the flange, due to both prestress and moments resisted by precast member acting alone), Sec 6.4
- f_r = Modulus of rupture of concrete, MPa, see Sections 6.2.5, 6.6
- f_s = Calculated tensile stress in reinforcement at service loads, MPa, Sec 6.3
- f'_s = Stress in compression reinforcement under factored loads, MPa, Sec I.3.5 Appendix I
- f_{uta} = Specified tensile strength of anchor steel, MPa, Appendix K
- f_y = Specified yield strength of reinforcement, MPa, Sections 6.2 to 6.4, 6.6, 6.9, 6.12, 8.1 to 8.3, I.4.1
- f_{ya} = Specified yield strength of anchor steel, MPa, Sec K.4.4 Appendix K
- f_{yt} = Specified yield strength f_y of transverse reinforcement, MPa, Sections 6.3, 6.4, 8.3.3.4
- F = Loads due to weight and pressures of fluids with well-defined densities and controllable maximum heights, or related internal moments and forces, Sec 6.2
- F_n = Nominal strength of a strut, tie, or nodal zone, N, Sec I.2.6 Appendix I
- F_{nn} = Nominal strength at face of a nodal zone, N, Sec I.5.1 Appendix I
- F_{ns} = Nominal strength of a strut, N, Sec I.3.1 Appendix I
- F_{nt} = Nominal strength of a tie, N, Sec I.4.1 Appendix I
- F_u = Factored force acting in a strut, tie, bearing area, or nodal zone in a strut-and-tie model, N, Sec I.2.6 Appendix I
- h = Overall thickness or height of member, mm, Sections 6.2 to 6.4, 6.6, 6.11, 6.12, 8.1.6, 8.3.4, I.1
- h_a = Thickness of member in which an anchor is located, measured parallel to anchor axis, mm, Sec K.6.2 Appendix K
- h_c = Cross-sectional dimension of member core measured to the outside edges of the transverse reinforcement composing area A_{sh} , mm, Sec 8.3.5

- h_{ef} = Effective embedment depth of anchor, mm, see Sec K.5.2, Appendix K
- h_f = Thickness of overhanging portion of the flange of a T-beam, Sec 6.3.15.2(b)
- h_v = Depth of shear head cross section, mm, Sec 6.4
- h_w = Height of entire wall from base to top or height of the segment of wall considered, mm, Sections 6.4, 8.3.6
- h_x = Maximum center-to-center horizontal spacing of crossties or hoop legs on all faces of the column, mm, Sec 8.3.5
- H = Loads due to weight and pressure of soil, water in soil, or other materials, or related internal moments and forces, Sec 6.2
- I = Moment of inertia of section about centroidal axis, mm⁴, Sections 6.3, 6.4
- I_b = Moment of inertia of gross section of beam about centroidal axis, mm⁴, Sec 6.5.6
- I_{cr} = Moment of inertia of cracked section transformed to concrete, mm⁴, Sec 6.2
- I_e = Effective moment of inertia for computation of deflection, mm⁴, Sec 6.2.5
- I_g = Moment of inertia of gross concrete section about centroidal axis, neglecting reinforcement, mm⁴, Sections 6.2, 6.3, 6.6
- I_s = Moment of inertia of gross section of slab about centroidal axis defined for calculating α_f and β_t , mm⁴, Sec 6.5
- I_{se} = Moment of inertia of reinforcement about centroidal axis of member cross section, mm⁴, Sec 6.3
- I_{sx} = Moment of inertia of structural steel shape, pipe, or tubing about centroidal axis of composite member cross section, mm⁴, Sec 6.3
- k = Effective length factor for compression members, Sections 6.3, 6.6
- k_c = Coefficient for basic concrete breakout strength in tension, Sec K.5.2 Appendix K
- k_{cp} = Coefficient for pryout strength, Sec K.6.3 Appendix K
- K_{tr} = Transverse reinforcement index, Sec 8.2.3.3

- l = Span length of beam or one-way slab; clear projection of cantilever, mm, Sec 6.2
- l_a = Additional embedment length beyond centerline of support or point of inflection, mm, Sec 8.2.8
- l_a = Length of clear span in short direction, Sec 6.5.8
- l_b = Length of clear span in long direction, Sec 6.5.8
- l_c = Length of compression member in a frame, measured center-to-center of the joints in the frame, mm, Sections 6.3, 6.6
- l_d = Development length in tension of deformed bar, deformed wire, plain and deformed welded wire reinforcement, or mm, Sections 6.9, 8.2.3, 8.3.6
- l_{dc} = Development length in compression of deformed bars and deformed wire, mm, Sec 8.2.4
- l_{dh} = Development length in tension of deformed bar or deformed wire with a standard hook, measured from critical section to outside end of hook (straight embedment length between critical section and start of hook [point of tangency] plus inside radius of bend and one bar diameter), mm, see Sections 8.2.6, 8.3.6
- l_{dt} = Development length in tension of headed deformed bar, measured from the critical section to the bearing face of the head, mm, Sections 8.2.17, 8.3.6
- l_e = Load bearing length of anchor for shear, mm, Sec K.6.2.2, Appendix K
- l_n = Length of clear span measured face-to-face of supports, mm, Sections 6.1 to 6.5, 6.10, 8.2.9, 8.3.4
- l_o = Length, measured from joint face along axis of structural member, over which special transverse reinforcement must be provided, mm, Sec 8.3.5
- l_t = Span of member under load test, taken as the shorter span for two-way slab systems, mm. Span is the smaller of: (a) distance between centers of supports, and (b) clear distance between supports plus thickness h of member. Span for a cantilever shall be taken as twice the distance from face of support to cantilever end, Sec 6.11
- l_u = Unsupported length of compression member, mm, Sec 6.3.10

- l_v = Length of shear head arm from centroid of concentrated load or reaction, mm, Sec 6.4
- l_w = Length of entire wall or length of segment of wall considered in direction of shear force, mm, Sections 6.4, 6.6, 8.3.6
- l_1 = Length of span in direction that moments are being determined, measured center-to-center of supports, mm, Sec 6.5
- l_1 = Length of clear span in direction that moment are being determined, Sec 6.5.8
- l_2 = Length of clear span transverse to l_1 , Sec 6.5.8
- l_2 = Length of span in direction perpendicular to l_1 , measured center-to-center of supports, mm, Sec 6.5.6
- L = Live loads, or related internal moments and forces, Sections 6.1, 6.2, 6.11, 8.3.12
- L_r = Roof live load, or related internal moments and forces, Sec 6.2
- M_a = Maximum moment in member due to service loads at stage deflection is computed, N·mm, Sections 6.2, 6.6
- M_a = Moment in the short direction, Sec 6.5.8
- M_b = Moment in the long direction, Sec 6.5.8
- M_c = Factored moment amplified for the effects of member curvature used for design of compression member, N·mm, see Sec 6.3.10.6
- M_{cr} = Cracking moment, N·mm, see Sec 6.2.5.2.3, Sections 6.2, 6.6
- M_{cre} = Moment causing flexural cracking at section due to externally applied loads, N·mm, Sec 6.4
- M_m = Factored moment modified to account for effect of axial compression, N·mm, Sec 6.4.2
- M_{max} = Maximum factored moment at section due to externally applied loads, N·mm, Sec 6.4
- M_n = Nominal flexural strength at section, N·mm, Sections 6.4, 6.6, 8.2.8, 8.3.12
- M_{n1} = Nominal flexural strength at section without compression steel, see Sec 6.3.15.1(b), and moment of resistance developed by compression in the overhanging portion of the T-flange, Sec 6.3.15.2

- M_{n2} = Additional nominal flexural strength at section due to added compression steel A'_s and additional tension steel A_{s2} , Sec 6.3.15.1, and moment of resistance developed by the web of a T-beam, Sec 6.3.15.2
- M_o = Total factored static moment, N·mm, Sec 6.5
- M_p = Required plastic moment strength of shear head cross section, N·mm, Sec 6.4
- M_{pr} = Probable flexural strength of members, with or without axial load, determined using the properties of the member at the joint faces assuming a tensile stress in the longitudinal bars of at least $1.25f_y$ and a strength reduction factor, ϕ , of 1.0, N·mm, Sec 8.3.8
- M_s = Factored moment due to loads causing appreciable sway, N·mm, Sec 6.3
- M_u = Factored moment at section, N·mm, Sections 6.3, 6.4, 6.5, 6.6, 8.3.6
- M_{ua} = Moment at mid height of wall due to factored lateral and eccentric vertical loads, not including P_Δ effects, N·mm, Sec 6.6
- M_v = Moment resistance contributed by shear head reinforcement, N·mm, Sec 6.4
- M_1 = Smaller factored end moment on a compression member, to be taken as positive if member is bent in single curvature, and negative if bent in double curvature, N·mm, Sec 6.3
- M_{1ns} = Factored end moment on a compression member at the end at which M_1 acts, due to loads that cause no appreciable side sway, calculated using a first-order elastic frame analysis, N·mm, Sec 6.3
- M_{1s} = Factored end moment on compression member at the end at which M_1 acts, due to loads that cause appreciable side sway, calculated using a first-order elastic frame analysis, N·mm, Sec 6.3
- M_2 = Larger factored end moment on compression member. If transverse loading occurs between supports, M_2 is taken as the largest moment occurring in member. Value of M_2 is always positive, N·mm, Sec 6.3
- $M_{2,mi}$ = Minimum value of M_2 , N·mm, Sec 6.3
- M_{2ns} = Factored end moment on compression member at the end at which M_2 acts, due to loads that cause no appreciable side sway, calculated using a first-order elastic frame analysis, N·mm, Sec 6.3

- M_{2s} = Factored end moment on compression member at the end at which M_2 acts, due to loads that cause appreciable sidesway, calculated using a first-order elastic frame analysis, N·mm, Sec 6.3
- n = Number of items, such as strength tests, bars, wires, monostrand anchorage devices, anchors, or shear head arms, Sec 6.4, 8.2, K.1
Width of flight, Figure 6.6.29.
- N_b = Basic concrete breakout strength in tension of a single anchor in cracked concrete, N, Sec K.5.2.2
- N_{cb} = Nominal concrete breakout strength in tension of a single anchor, N, see Sec K.5.2.1
- N_{cbg} = Nominal concrete breakout strength in tension of a group of anchors, N, Sec K.5.2.1
- N_n = Nominal strength in tension, N, Sec K.3.3
- N_p = Pullout strength in tension of a single anchor in cracked concrete, N, Sections K.2.3 K.3.3, K.5.3
- N_{pn} = Nominal pullout strength in tension of a single anchor, N, Sections K.4.1, K.5.3
- N_{sa} = Nominal strength of a single anchor or group of anchors in tension as governed by the steel strength, N, Sections K.4.1, K.5.1
- N_{sb} = Side-face blowout strength of a single anchor, N, Sec K.4.1
- N_{sbg} = Side-face blowout strength of a group of anchors, N, Sections K.4.1, K.5.4
- N_u = Factored axial force normal to cross section occurring simultaneously with V_u or T_u ; to be taken as positive for compression and negative for tension, N, Sec 6.4
- N_{ua} = Factored tensile force applied to anchor or group of anchors, N, Sections K.4.1, K.7
- N_{uc} = Factored horizontal tensile force applied at top of bracket or corbel acting simultaneously with V_u , to be taken as positive for tension, N, Sec 6.4
- p_{cv} = Outside perimeter of concrete cross section, mm, Sec 6.4.4.1
- p_h = Perimeter of centerline of outermost closed transverse torsional reinforcement, mm, Sec 6.4

- P_b = Nominal axial strength at balanced strain conditions, N, Sections 6.2, 6.3.3
- P_c = Critical buckling load, N, Sec 6.3.10
- P_n = Nominal axial strength of cross section, N, Sections 6.2, 6.3, 6.6
- $P_{n,max}$ = Maximum allowable value of P_n , N, Sec 6.3.3
- P_o = Nominal axial strength at zero eccentricity, N, Sec 6.3
- P_s = Unfactored axial load at the design (mid height) section including effects of self-weight, N, Sec 6.6
- P_u = Factored axial force; to be taken as positive for compression and negative for tension, N, Sections 6.3, 6.6
- q_{Du} = Factored dead load per unit area, Sec 6.5
- q_{Lu} = Factored live load per unit area, Sec 6.5
- q_u = Factored load per unit area, Sec 6.5
- Q = Stability index for a story, Sec 6.3.10.5.2
- r = Radius of gyration of cross section of a compression member, mm, Sec 6.3
- R = Rain load, or related internal moments and forces, Sec 6.2
- s = Center-to-center spacing of items, such as longitudinal reinforcement, transverse reinforcement, wires, or anchors, mm, Sections 6.3, 6.4, 6.9, 6.11, 6.12, 8.2.3, 8.3.4, Appendix K
- s_i = Center-to-center spacing of reinforcement in the i -th layer adjacent to the surface of the member, mm, Sec 1.3.3
- s_o = Center-to-center spacing of transverse reinforcement within the length l_o , mm, Sec 8.3.10
- s_s = Sample standard deviation, MPa, Sec K.1
- s_2 = Center-to-center spacing of longitudinal shear or torsion reinforcement, mm, Sec 6.4
- t = Wall thickness of hollow section, mm, Sec 6.4
- T = Cumulative effect of temperature, creep, shrinkage, differential settlement, and shrinkage-compensating concrete, Sec 6.2

- T_n = Nominal torsional moment strength, N·mm, Sec 6.4
- T_u = Factored torsional moment at section, N·mm, Sec 6.4
- U = Required strength to resist factored loads or related internal moments and forces, Sec 6.2
- v_n = Nominal shear stress, MPa, Sections 6.4, 8.3.8
- V_b = Basic concrete breakout strength in shear of a single anchor in cracked concrete, N, Sec K.6.2
- V_c = Nominal shear strength provided by concrete, N, Sections 6.1, 6.4, 6.5, 8.3.8
- V_{cb} = Nominal concrete breakout strength in shear of a single anchor, N, Sections K.4.1, K.6.2
- V_{cbg} = Nominal concrete breakout strength in shear of a group of anchors, N, Sections K.4.1, K.6.2
- V_{ci} = Nominal shear strength provided by concrete when diagonal cracking results from combined shear and moment, N, Sec 6.4
- V_{cp} = Nominal concrete pryout strength of a single anchor, N, Sec K.6.3.1
- V_{cpg} = Nominal concrete pryout strength of a group of anchors, N, Sec K.6.3.1
- V_{cw} = Nominal shear strength provided by concrete when diagonal cracking results from high principal tensile stress in web, N, Sec 6.4
- V_d = Shear force at section due to unfactored dead load, N, Sec 6.4
- V_e = Design shear force corresponding to the development of the probable moment strength of the member, N, Sec 8.3.8
- V_n = Nominal shear strength, N, Sections 6.1, 6.3, 6.4, 8.3.6, K.3.3
- V_{nh} = Nominal horizontal shear strength, N, Sec 6.12
- V_s = Nominal shear strength provided by shear reinforcement, N, Sec 6.4
- V_{sa} = Nominal strength in shear of a single anchor or group of anchors as governed by the steel strength, N, see Sections K.3.3, K.6.1.1, K.6.1.2
- V_u = Factored shear force at section, N, Sections 6.4, 6.5, 6.12, 8.2.7, 8.3.6
- V_{ua} = Factored shear force applied to a single anchor or group of anchors, N, K.4.1

- V_{ug} = Factored shear force on critical section of two-way slab action due to gravity loads, N, Sec 8.3.12
- V_{us} = Factored horizontal shear in a story, N, Sec 6.3
- w = Uniform load, Sec 6.5.8
- wl_c = Density (unit weight) of normal weight concrete or equilibrium density of light weight concrete, kg/m³, Sections 6.1, 6.2
- w_u = Factored load per unit length of beam or one way slab, Sec 6.1
- W = Wind load, or related internal moments and forces, Sec 6.2
- x = Shorter overall dimension of rectangular part of cross section, mm, Sec 6.5
- y = Longer overall dimension of rectangular part of cross section, mm, Sec 6.5
- y_t = Distance from centroidal axis of gross section, neglecting reinforcement, to tension face, mm, Sections 6.2, 6.4
- α = Angle defining the orientation of reinforcement, Sections 6.4, I.3.3
- α_c = Coefficient defining the relative contribution of concrete strength to nominal wall shear strength, Sec 8.3.6
- α_f = Ratio of flexural stiffness of beam section to flexural stiffness of a width of slab bounded laterally by centerlines of adjacent panels (if any) on each side of the beam, Sections 6.2, 6.4.2, 6.5.6, 6.5.8
- α_{fm} = Average value of α_f for all beams on edges of a panel, Sec 6.2
- α_{f1} = α_f in direction of l_1 , Sec 6.5
- α_{f2} = α_f in direction of l_2 , Sec 6.5
- α_i = Angle between the axis of a strut and the bars in the i -th layer of reinforcement crossing that strut, Sec I.3.3
- α_s = Constant used to compute V_c in slabs and footings, Sec 6.4
- α_v = Ratio of flexural stiffness of shear head arm to that of the surrounding composite slab section, Sec 6.4.10
- β = Ratio of long to short dimensions: clear spans for two-way slabs, Sec 6.2.5 sides of column, concentrated load or reaction area, Sec 6.4.10; or sides of a footing, Sections 6.2, 6.4, 6.8.4

- β_b = Ratio of area of reinforcement cut off to total area of tension reinforcement at section, Sec 8.2.7
- β_{dns} = Ratio used to account for reduction of stiffness of columns due to sustained axial loads, Sec 6.3.10
- β_{ds} = Ratio used to account for reduction of stiffness of columns due to sustained lateral loads, Sec 6.3.10.4
- β_n = Factor to account for the effect of the anchorage of ties on the effective compressive strength of a nodal zone, Sec I.5.2
- β_s = Factor to account for the effect of cracking and confining reinforcement on the effective compressive strength of the concrete in a strut, Sec I.3.2
- β_t = Ratio of torsional stiffness of edge beam section to flexural stiffness of a width of slab equal to span length of beam, center-to-center of supports, Sec 6.5.6.4
- β_1 = Factor relating depth of equivalent rectangular compressive stress block to neutral axis depth, Sec 6.3.2.7
- γ_f = Factor used to determine the unbalanced moment transferred by flexure at slab-column connections, Sections 6.4, 6.5.5.3
- γ_s = Factor used to determine portion of reinforcement located in center band of footing, Sec 6.8.4.4
- γ_v = Factor used to determine the unbalanced moment transferred by eccentricity of shear at slab-column connections, Sec 6.4.10.7
- δ = Moment magnification factor to reflect effects of member curvature between ends of compression member, Sec 6.3
- δ_s = Moment magnification factor for frames not braced against side sway, to reflect lateral drift resulting from lateral and gravity loads, Sec 6.3
- δ_u = Design displacement, mm, Sec 8.3.6
- Δ_{cr} = Computed, out-of-plane deflection at mid height of wall corresponding to cracking moment, M_{cr} , mm, Sec 6.6
- Δ_n = Computed, out-of-plane deflection at mid height of wall corresponding to nominal flexural strength, M_n , mm, Sec 6.6
- Δ_o = Relative lateral deflection between the top and bottom of a story due to lateral forces computed using a first-order elastic frame analysis and stiffness values satisfying Sec 6.3
- Δ_r = Difference between initial and final (after load removal) deflections for load test or repeat load test, mm, Sec 6.11

- Δ_s = Computed, out-of-plane deflection at mid height of wall due to service loads, mm, Sec 6.6
- Δ_u = Computed deflection at mid height of wall due to factored loads, mm, Sec 6.6
- Δ_1 = Measured maximum deflection during first load test, mm, Sec 6.11.5.2
- Δ_2 = Maximum deflection measured during second load test relative to the position of the structure at the beginning of second load test, mm, Sec 6.11.5.2
- ε_t = Net tensile strain in extreme layer of longitudinal tension steel at nominal strength, creep, shrinkage, and temperature, Sections 6.1 to 6.3
- θ = Angle between axis of strut, compression diagonal, or compression field and the tension chord of the member, Sec 6.4.4
- λ = Modification factor reflecting the reduced mechanical properties of lightweight concrete, all relative to normal weight concrete of the same compressive strength, Sections 6.1.8.1, 6.2, 6.4.5.4, 6.9, 8.2.3.4, 8.2.6.2, 8.2.10.2, 8.3.6, I.3.2, K.5.2
- λ_Δ = Multiplier for additional deflection due to long-term effects, Sec 6.2.5.2.5
- μ = Coefficient of friction, Sec 6.4.5.4.3
- ξ = Time-dependent factor for sustained load, Sec 6.2.5.2
- ρ = Ratio of A_s to bd , Sections 6.4, 6.5, 8.3.4
- ρ' = Ratio of A'_s to bd , Sections 6.2, 6.3.15.1
- ρ_b = Ratio of A_s to bd producing balanced strain conditions, Sections 6.3.3.2, 6.5, 6.6
- ρ_f = Ratio of A_{sf} to $b_w d$, Sec 6.3.15.2
- ρ_l = Ratio of area of distributed longitudinal reinforcement to gross concrete area perpendicular to that reinforcement, Sections 6.4, 6.6, 8.3.6
- ρ_{max} = Maximum reinforcement ratio allowed for beams corresponding to $\varepsilon_t = 0.004$, Sec 6.3.15.1

- ρ_s = Ratio of volume of spiral reinforcement to total volume of core confined by the spiral (measured out-to-out of spirals), Sections 6.3, 8.3.5
- ρ_t = Ratio of area distributed transverse reinforcement to gross concrete area perpendicular to that reinforcement, Sections 6.4, 6.6, 8.3.6
- ρ_v = Ratio of tie reinforcement area to area of contact surface, Sec 6.12.5.3
- ρ_w = Ratio of A_s to $b_w d$, Sections 6.3.15.2, 6.4
- φ = Strength reduction factor, see Sec 6.2.3, Sections 6.1 to 6.6, 6.9, 6.11, 6.12, 8.3.12, I.2.6, K.2.1
- $\psi_{c,N}$ = Factor used to modify tensile strength of anchors based on presence or absence of cracks in concrete, Sec K.5.2
- $\psi_{c,P}$ = Factor used to modify pullout strength of anchors based on presence or absence of cracks in concrete, Sec K.5.3
- $\psi_{c,V}$ = Factor used to modify shear strength of anchors based on presence or absence of cracks in concrete and presence or absence of supplementary reinforcement, Sec K.6.2 for anchors in shear
- ψ_e = Factor used to modify development length based on reinforcement coating, Sec 8.2.3
- $\psi_{ec,N}$ = Factor used to modify tensile strength of anchors based on eccentricity of applied loads, Sec K.5.2
- $\psi_{ec,V}$ = Factor used to modify shear strength of anchors based on eccentricity of applied loads, Sec K.6.2
- $\psi_{ed,N}$ = Factor used to modify tensile strength of anchors based on proximity to edges of concrete member, Sec K.5.2
- $\psi_{ed,V}$ = Factor used to modify shear strength of anchors based on proximity to edges of concrete member, Sec K.6.2
- $\psi_{h,V}$ = Factor used to modify shear strength of anchors located in concrete members with $h_a < 1.5c_{a1}$, Sec K.6.2
- ψ_s = Factor used to modify development length based on reinforcement size, Sec 8.2.3
- ψ_t = Factor used to modify development length based on reinforcement location, Sec 8.2.3
- ψ_w = Factor used to modify development length for welded deformed wire reinforcement in tension, Sec 8.2.18

6.1.3 General

6.1.3.1 Members shall be designed for adequate strength in accordance with the provisions of this Chapter, using load factors specified in Sec 2.7.3.1 and strength reduction factors ϕ in Sec 6.2.3.1.

6.1.3.2 Design of reinforced concrete members using Working Stress Design method (Appendix J) is also permitted.

6.1.3.3 Structures and structural members shall be designed to have design strength at all sections at least equal to the required strength (U) calculated for the factored loads and forces in such combinations as are stipulated in Chapter 2, Loads. The nominal strength provided for the section multiplied by the strength reduction factor ϕ shall be equal to or greater than the calculated required strength U.

6.1.3.4 Members shall also meet all the other requirements of this Code to ensure adequate performance at service loads.

6.1.3.5 Design strength of reinforcement represented by the values of f_y and f_{yt} used in design calculations shall not exceed 550 MPa, and for transverse reinforcement in Sections 6.3.9.3 and 8.3. f_y or f_{yt} may exceed 420 MPa, only if the ratio of the actual tensile strength to the actual yield strength is not less than 1.20, and the elongation percentage is not less than 16.

6.1.3.6 For structural concrete, f'_c shall not be less than 17 MPa. No maximum value of f'_c shall apply unless restricted by a specific Code provision.

6.1.4 Loading

6.1.4.1 Loads and their combinations shall be in accordance with the requirements specified in Chapter 2 of this Part.

6.1.4.2 Structures shall be designed to resist all applicable loads.

6.1.4.3 Effects of forces due to crane loads, vibration, impact, shrinkage, temperature changes, creep, expansion of shrinkage-compensating concrete, and unequal settlement of supports shall be duly considered.

6.1.4 Methods of Analysis

6.1.4.1 Members of frames or continuous construction (beams or one-way slabs) shall be designed for the maximum effects of factored loads as determined by the theory of elastic analysis, except as modified for redistribution of moments in continuous flexural members according to Sec 6.1.5. Design is permitted to be simplified by using the assumptions specified in Sections 6.1.6, 6.1.9 to 6.1.12.

6.1.4.2 Frame analysis by approximate methods shall be permitted for buildings of usual types of construction, spans, and story heights.

6.1.4.3 Provided (a) to (e) below are satisfied, the approximate moments and shears given here shall be permitted for design of continuous beams and one-way slabs (slabs reinforced to resist flexural stresses in only one direction), as an alternate to frame analysis:

- (a) There are two or more spans;
- (b) Spans are approximately equal, with the larger of two adjacent spans not greater than the shorter by more than 20 percent;
- (c) Loads are uniformly distributed;
- (d) Unfactored live load, L , does not exceed three times unfactored dead load, D ; and
- (e) Members are prismatic.

For calculating negative moments, l_n is taken as the average of the adjacent clear span lengths.

Positive moment

End spans

Discontinuous end unrestrained $w_u l_n^2 / 11$

Discontinuous end integral with support $w_u l_n^2 / 14$

Interior spans $w_u l_n^2 / 16$

Negative moments at exterior face of first interior support

Two spans $w_u l_n^2 / 9$

More than two spans $w_u l_n^2 / 10$

Negative moment at other faces of interior supports $w_u l_n^2 / 11$

Negative moment at face of all supports for Slabs with spans not exceeding 3.048 m; and beams where ratio of sum of column stiffness to beam stiffness exceeds 8 at each end of the span $w_u l_n^2 / 12$

Negative moment at interior face of exterior support for members built integrally with supports

Where support is spandrel beam $w_u l_n^2 / 24$

Where support is a column $w_u l_n^2 / 16$

Shear in end members at face of first interior support $1.15w_u l_n / 2$

Shear at face of all other supports $w_u l_n / 2$

6.1.4.4 Strut-and-tie models, provided in Appendix I, shall be permitted to be used in the design of structural concrete.

6.1.5 Redistribution of Moments in Continuous Flexural Members

6.1.5.1 It shall be permitted to decrease factored moments calculated by elastic theory at sections of maximum negative or maximum positive moment in any span of continuous flexural members for any assumed loading arrangement by not more than $1000\varepsilon_t$ percent, with a maximum of 20 percent, except where approximate values for moments are used.

6.1.5.2 Redistribution of moments shall be made only when ε_t is equal to or greater than 0.0075 at the section at which moment is reduced.

6.1.5.3 At all other sections within the spans, the reduced moment shall be used for calculating redistributed moments. Static equilibrium shall have to be maintained after redistribution of moments for each loading arrangement.

6.1.6 Span Length

6.1.6.1 The span length of a simply supported beam shall be taken as the smaller of the distance between the centres of bearings, or the clear distance between supports plus the effective depth.

6.1.6.2 For determination of moments in analysis of frames or continuous construction, span length shall be taken as the distance center-to-center of supports.

6.1.6.3 Design on the basis of moments at faces of support shall be permitted for beams built integrally with supports.

6.1.6.4 It shall be permitted to analyze solid or ribbed slabs built integrally with supports, with clear spans not more than 3 m, as continuous slabs on knife edge supports with spans equal to the clear spans of the slab and width of beams otherwise neglected.

6.1.6.5 The effective length of a cantilever is its length to the face of the support plus half its effective depth, except where it forms the end of a continuous beam, where the length to the centre of support shall be used.

6.1.7 Modulus of Elasticity

6.1.7.1 Modulus of elasticity, E_c , for concrete shall be permitted to be taken as $w_c^{1.5}0.043\sqrt{f'_c}$ (in MPa) for values of w_c between 1440 and 2560 kg/m³. For normal weight concrete, E_c shall be permitted to be taken as $4700\sqrt{f'_c}$ (in MPa).

6.1.7.2 Modulus of elasticity, E_s , for reinforcement shall be permitted to be taken as 200,000 MPa.

6.1.8 Lightweight Concrete

6.1.8.1 To account for the use of lightweight concrete, unless specifically noted otherwise, a modification factor λ appears as a multiplier of $\sqrt{f'_c}$ in all applicable equations and sections of this Code, where, $\lambda = 0.85$ for sand-lightweight concrete and 0.75 for all-lightweight concrete. Linear interpolation between 0.75 and 0.85 shall be permitted, on the basis of volumetric fractions, when a portion of the lightweight fine aggregate is replaced with normal weight fine aggregate. Linear interpolation between 0.85 and 1.0 shall be permitted, on the basis of volumetric fractions, for concrete containing normal weight fine aggregate and a blend of lightweight and normal weight coarse aggregates. For normal weight concrete, $\lambda = 1.0$. If average splitting tensile strength of lightweight concrete, f_{ct} , is specified, $\lambda = \frac{f_{ct}}{0.56\sqrt{f'_c}} \leq 1.0$

6.1.9 Stiffness

6.1.9.1 For computing relative flexural and torsional stiffnesses of columns, walls, floors, and roof systems, use of any set of reasonable assumptions shall be permitted. The assumptions adopted shall be consistent throughout analysis.

6.1.9.2 Both in determining moments and in design of members, effect of haunches shall be considered.

6.1.10 Effective Stiffness for Determining Lateral Deflections

6.1.10.1 Lateral deflections resulting from service lateral loads for reinforced concrete building systems shall be computed by either a linear analysis with member stiffness determined using 1.4 times the flexural stiffness defined in Sections 6.1.11.2 and 6.1.11.3 or by a more detailed analysis. Member properties shall not be taken greater than the gross section properties.

6.1.10.2 Lateral deflections resulting from factored lateral loads for reinforced concrete building systems shall be computed either by linear analysis with member stiffness defined by (a) or (b), or by a more detailed analysis considering the reduced stiffness of all members under the loading conditions:

- (a) By section properties defined in Sec 6.3.10.4.1(a) to (c); or
- (b) 50 percent of stiffness values based on gross section properties.

6.1.10.3 Lateral deflections resulting from factored lateral loads shall be permitted to be computed by using linear analysis, where two-way slabs without beams are designated as part of the seismic-force-resisting system. The stiffness of slab members shall be defined by a model that is in substantial agreement with results of comprehensive tests and analysis and the stiffness of other frame members shall be as defined in Sec 6.1.11.2.

6.1.11 Considerations for Columns

6.1.11.1 Columns shall be designed to resist the axial forces from factored loads on all floors or roof and the maximum moment from factored loads on a single adjacent span of the floor or roof under consideration. Loading condition resulting the maximum ratio of moment to axial load shall also be considered.

6.1.11.2 In frames or continuous construction, consideration shall be given to the effect of unbalanced floor or roof loads on both exterior and interior columns and of eccentric loading due to other causes.

6.1.11.3 It shall be permitted to assume far ends of columns built integrally with the structure to be fixed, while computing gravity load moments in columns.

6.1.11.4 Resistance to moments at any floor or roof level shall be provided by distributing the moment between columns immediately above and below the given floor in proportion to the relative column stiffnesses and conditions of restraint.

6.1.12 Live Load Arrangement

6.1.12.1 The following shall be permitted to assume:

- (a) The live load is applied only to the floor or roof under consideration; and
- (b) The far ends of columns built integrally with the structure are considered to be fixed.

6.1.12.2 Arrangement of live load shall be permitted to be assumed to be limited to combinations of:

- (a) Factored dead load on all spans with full factored live load on two adjacent spans; and
- (b) Factored dead load on all spans with full factored live load on alternate spans.

6.1.13 Construction of T-beam

6.1.13.1 In the construction of T-beam, the flange and web shall be built integrally or otherwise effectively bonded together.

6.1.13.2 Width of slab effective as a T-beam flange shall not exceed one-quarter of the span length of the beam, and the effective overhanging flange width on each side of the web shall not exceed:

- (a) Eight times the slab thickness; and
- (b) One-half the clear distance to the next web.

6.1.13.3 The effective overhanging flange width for beams with a slab on one side only shall not exceed:

- (a) One-twelfth the span length of the beam;
- (b) Six times the slab thickness; and
- (c) One-half the clear distance to the next web.

6.1.13.4 Isolated beams, in which the T-shape is used to provide a flange for additional compression area, shall have a flange thickness not less than one-half the width of web and an effective flange width not more than four times the width of web.

6.1.13.5 When primary flexural reinforcement in a slab that is considered as a T-beam flange (excluding joist construction) is parallel to the beam, reinforcement shall be provided in the top of the slab in the direction perpendicular to the beam and in accordance with the following:

6.1.13.5.1 Transverse reinforcement shall be designed to carry the factored load on the overhanging slab width assumed to act as a cantilever. For isolated beams, the full width of overhanging flange shall be considered. For other T-beams, only the effective overhanging slab width need be considered.

6.1.13.5.2 Spacing of transverse reinforcement shall be not farther apart than five times the slab thickness, nor farther apart than 450 mm.

6.1.14 Construction of Joist

6.1.14.1 Construction of joist consists of a monolithic combination of regularly spaced ribs and a top slab arranged to span in one direction or two orthogonal directions.

6.1.14.2 Width of ribs shall not be less than 100 mm, and the ribs shall have a depth of not more than 3.5 times the minimum width of rib.

6.1.14.3 Clear spacing between ribs shall not exceed 750 mm.

6.1.14.4 Joist construction not meeting the limitations of Sections 6.1.15.1 to 6.1.15.3 shall be designed as slabs and beams.

6.1.14.5 When permanent burned clay or concrete tile fillers of material having a unit compressive strength at least equal to f'_c in the joists are used:

6.1.14.5.1 For shear and negative moment strength computations, the vertical shells of fillers in contact with the ribs shall be permitted to include. Other portions of fillers shall not be included in strength computations.

6.1.14.5.2 Slab thickness over permanent fillers shall be not less than 1/12th the clear distance between ribs, nor less than 40 mm.

6.1.14.5.3 Reinforcement normal to the ribs shall be provided in the in one-way joists, as required by Sec 8.1.11

6.1.14.6 When removable forms or fillers are used, which do not comply with Sec 6.1.15.5, then:

6.1.14.6.1 Slab thickness shall be not less than $1/12^{\text{th}}$ the clear distance between ribs, nor less than 50 mm.

6.1.14.6.2 Reinforcement normal to the ribs shall be provided in the slab as required for flexure, considering load concentrations, if any, but not less than required by Sec 8.1.11

6.1.14.7 Where conduits or pipes as permitted by relevant provisions of embedments in concrete are embedded within the slab, slab thickness shall be at least 25 mm greater than the total overall depth of the conduits or pipes at any point. Conduits or pipes shall not impair significantly the strength of the construction.

6.1.14.8 For joist construction, V_c shall be permitted to be 10 percent more than that specified in Sec 6.4.

6.1.15 Separate Floor Finish

6.1.15.1 Unless placed monolithically with the floor slab or designed in accordance with requirements of Sec. 6.12, floor finish shall not be included as part of a structural member.

6.1.15.2 All concrete floor finishes shall be permitted to be considered as part of required cover or total thickness for nonstructural considerations.

6.2 Strength and Serviceability Requirements

6.2.1 General

6.2.1.1 Structures and structural members shall be designed to have design strengths at all sections at least equal to the required strengths calculated for the factored loads and forces in such combinations as are stipulated in this Code.

6.2.1.2 Members also shall meet all other requirements of this Code to ensure adequate performance at service load levels.

6.2.2 Required Strength

6.2.2.1 Required strength U shall be at least equal to the effects of factored loads in such combinations as are stipulated in Chapter 2, Loads.

6.2.2.2 If resistance to impact effects is taken into account in design, such effects shall be included with L .

6.2.2.3 Estimations of differential settlement, creep, shrinkage, expansion of shrinkage-compensating concrete, or temperature change shall be based on a realistic assessment of such effects occurring in service.

6.2.2.4 For structures like emergency preparedness centre, cyclone shelters etc. in coastal zone, in load combination 4 of Sec 2.7.3.1 of Chapter 2, the coefficient of live load L shall be taken 1.6 instead of 1.0.

6.2.3 Design Strength

6.2.3.1 Design strength provided by a member, and its connections to other members, in terms of flexure, axial load, shear, and torsion, shall be taken as the nominal strength calculated in accordance with the requirements and assumptions of this Chapter, multiplied by a strength reduction factors ϕ as stipulated in Sections 6.2.3.2 to 6.2.3.4.

6.2.3.2 Strength reduction factor ϕ is given in Sections 6.2.3.2.1 to 6.2.3.2.6:

6.2.3.2.1 For tension-controlled sections as defined in Sec 6.3.3.4: 0.90

6.2.3.2.2 For compression-controlled sections, as defined in Sec 6.3.3.3:

Members with spiral reinforcement conforming to Sec 6.3.9.3: 0.75

Other reinforced members: 0.65

For sections in which the net tensile strain in the extreme tension steel at nominal strength, ε_t , is between the limits for compression-controlled and tension-controlled sections, ϕ shall be permitted to be linearly increased from that for compression-controlled sections to 0.90 as ε_t increases from the compression controlled strain limit to 0.005 (Also see Figure 6.6.1). While interpolating, it shall be permitted to round ϕ to second digit after decimal.

6.2.3.2.3 It shall be permitted for compression-controlled sections, as defined in Sec 6.3.3.3, the following optional, more conservative alternative values of strength reduction factor ϕ , where less controlled construction environment justifies such selection according to engineering judgment of the designer:

For members with spiral reinforcement conforming to Sec 6.3.9.3: 0.70

For other reinforced members: 0.60

For sections in which the net tensile strain in the extreme tension steel at nominal strength, ε_t , is between the limits for compression-controlled and tension-controlled sections, ϕ shall be permitted to be linearly increased from that for compression-controlled sections to 0.90 as ε_t increases from the compression controlled strain limit to 0.005 (Also see Figure 6.6.2). While interpolating, it shall be permitted to round ϕ to second digit after decimal.

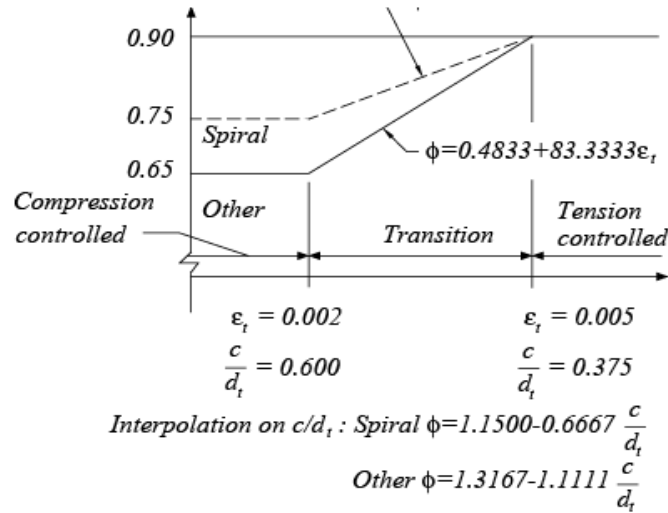


Figure 6.6.1 Variation of ϕ with net tensile strain in extreme tension steel, ϵ_t and c/d_t for Grade 420 reinforcement and for prestressing steel

6.2.3.2.4 Strength reduction factor for shear and torsion: 0.75

6.2.3.2.5 Strength reduction factor for bearing on concrete (except for post-tensioned anchorage zones and strut-and-tie models): 0.65

6.2.3.2.6 Strength reduction factor for strut-and-tie models (Appendix I), and struts, ties, nodal zones, and bearing areas in such models: 0.75

6.2.3.2.7 Calculation of development length specified in Sec 8.2 does not require strength reduction factor ϕ .

6.2.3.3 For structures relying on intermediate precast structural walls in Seismic Design Category D, special moment frames, or special structural walls to resist earthquake effects, E , ϕ shall be modified as given in (a) through (c):

- (a) For any structural member that is designed to resist E , if the nominal shear strength of the member is less than the shear corresponding to the development of the nominal flexural strength of the member, ϕ for shear shall be 0.60. The nominal flexural strength shall be determined considering the most critical factored axial loads and including E ;
- (b) For diaphragms, ϕ for shear shall not exceed the minimum ϕ for shear used for the vertical components of the primary seismic-force-resisting system;
- (c) For joints and diagonally reinforced coupling beams, ϕ for shear shall be 0.85.

6.2.3.4 Strength reduction factor ϕ shall be 0.60 for flexure, compression, shear, and bearing of structural plain concrete.

6.2.4 Design Strength for Reinforcement

The values of f_y and f_{yt} used in design calculations shall not exceed 550 MPa, except for transverse reinforcement in Sections 6.3.9.3 and 8.3.

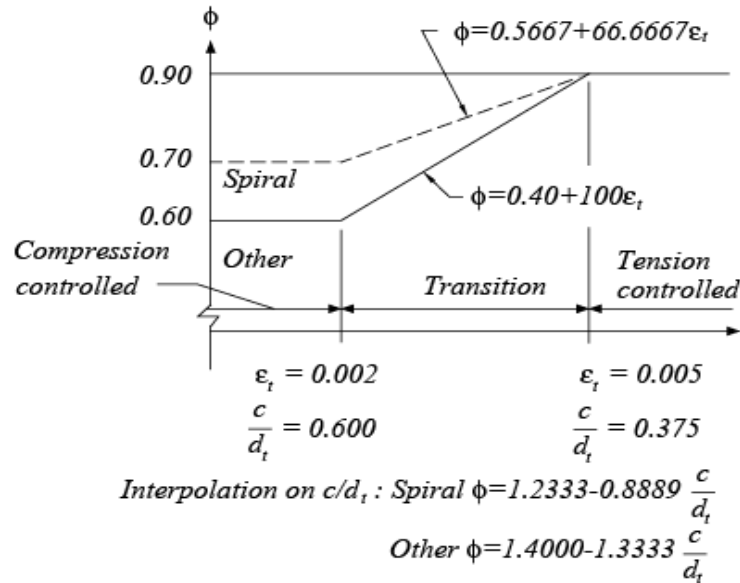


Figure 6.6.2 Variation of ϕ with net tensile strain in extreme tension steel, ϵ_t and c/d_t for Grade 420 reinforcement and for prestressing steel with reduced values of ϕ (0.6 and 0.7) for compression controlled sections (see Sec.6.2.3.2.3, Optional application in case of less controlled environment as per engineering judgment)

6.2.5 Control of Deflections

6.2.5.1 Reinforced concrete members subjected to flexure shall be designed to have adequate stiffness to limit deflections or any deformations that may adversely affect strength or serviceability of a structure.

6.2.5.2 One-way construction (non prestressed)

6.2.5.2.1 Minimum thickness stipulated in Table 6.6.1 shall apply for one-way construction not supporting or attached to partitions or other construction likely to be damaged by large deflections, unless computation of deflection indicates a lesser thickness can be used without adverse effects.

6.2.5.2.2 Where deflections are to be computed, deflections that occur immediately on application of load shall be computed by usual methods or formulas for elastic deflections, considering effects of cracking and reinforcement on member stiffness.

6.2.5.2.3 If not stiffness values are obtained by a more comprehensive analysis, immediate deflection shall be computed with the modulus of elasticity for concrete, E_c , as specified in 6.1.7.1 (normal weight or lightweight concrete) and with the effective moment of inertia, I_e , as follows, but not greater than I_g

$$I_e = \left(\frac{M_{cr}}{M_a}\right)^3 I_g + \left[1 - \left(\frac{M_{cr}}{M_a}\right)^3\right] I_{cr} \quad (6.6.1)$$

Where,

$$M_{cr} = \frac{f_r I_g}{y_t} \quad (6.6.2)$$

And,

$$f_r = 0.62\lambda\sqrt{f'_c} \quad (6.6.3)$$

Table 6.6.1: Minimum Thickness of Non prestressed beams or one-Way slabs Unless Deflections are calculated

Member	Minimum thickness, h			
	Simply supported	One end continuous	Both ends continuous	Cantilever
	Members not supporting or attached to partitions or other construction likely to be damaged by large deflections			
Solid one- way slabs	1/ 20	1/ 24	1/ 28	1/ 10
Beams or ribbed one- way slabs	1/16	1/18.5	1/ 21	1/ 8

Notes:

Values given shall be used directly for members with normal weight concrete and Grade 420 reinforcement. For other conditions, the values shall be modified as follows:

- For lightweight concrete having equilibrium density, w_c , in the range of 1440 to 1840 kg/m³, the values shall be multiplied by $(1.65 - 0.0003w_c)$ but not less than 1.09.
- For f_y other than 420MPa, the values shall be multiplied by $(0.4 + f_y / 700)$.

6.2.5.2.4 I_e shall be permitted to be taken for continuous members as the average of values obtained from Eq. 6.6.1 for the critical positive and negative moment sections. For prismatic members, I_e shall be permitted to be taken as the value obtained from Eq. 6.6.1 at mid span for simple and continuous spans, and at support for cantilevers.

6.2.5.2.5 If the values are not obtained by a more comprehensive analysis, additional long-term deflection resulting from creep and shrinkage of flexural members (normal weight or lightweight concrete) shall be determined by multiplying the immediate deflection caused by the sustained load considered, by the factor λ_{Δ}

$$\lambda_{\Delta} = \frac{\xi}{1+50\rho'} \quad (6.6.4)$$

Where, ρ' shall be the value at midspan for simple and continuous spans, and at support for cantilevers. It shall be permitted to assume ξ , the time-dependent factor for sustained loads, to be equal to:

5 years or more	2.0
12 months	1.4
6 months	1.2
3 months	1.0

6.2.5.2.6 The value of deflection computed in accordance with Sections 6.2.5.2.2 to 6.2.5.2.5 shall not exceed limits stipulated in Table 6.6.2.

6.2.5.3 Two-way construction (non prestressed)

6.2.5.3.1 The minimum thickness of slabs or other two-way construction designed in accordance with the provisions of Sec. 6.5 and conforming to the requirements of Sec 6.5.6.1.2 shall be governed by Sec 6.2.5.3. The thickness of slabs without interior beams spanning between the supports on all sides shall satisfy the requirements of Sec 6.2.5.3.2 or Sec 6.2.5.3.4. The thickness of slabs with beams spanning between the supports on all sides shall satisfy requirements of Sec 6.2.5.3.3 or Sec 6.2.5.3.4.

6.2.5.3.2 If slabs are without interior beams spanning between the supports and have a ratio of long to short span not greater than 2, the minimum thickness shall be in accordance with the provisions of Table 6.6.3 and shall not be less than the following values:

Slabs without drop panels as defined in Sec 6.5.2.5:	125 mm
Slabs with drop panels as defined in Sec 6.5.2.5:	100 mm

Table 6.6.2: Maximum Allowable Computed Deflections

Type of member	Deflection to be considered	Deflection limitation
Flat roofs not supporting or attached to nonstructural elements likely to be damaged by large deflections	Immediate deflection due to live load L	$l/180^*$
Floors not supporting or attached to nonstructural elements likely to be damaged by large deflections		$l/360$
Roof or floor construction supporting or attached to nonstructural elements likely to be damaged by large deflections	That part of the total deflection occurring after attachment of nonstructural elements (sum of the long-term deflection due to all sustained loads and the immediate deflection due to any additional live load)†	$l/480‡$
Roof or floor construction supporting or attached to nonstructural elements not likely to be damaged by large deflections		$l/240§$

* Limit not intended to safeguard against ponding. Ponding should be checked by suitable calculations of deflection, including added deflections due to ponded water, and considering long-term effects of all sustained loads, camber, construction tolerances, and reliability of provisions for drainage.

† Long-term deflection shall be determined in accordance with Sec 6.2.5.2.5, but may be reduced by amount of deflection calculated to occur before attachment of nonstructural elements. This amount shall be determined on basis of accepted engineering data relating to time-deflection characteristics of members similar to those being considered.

‡ Limit may be exceeded if adequate measures are taken to prevent damage to supported or attached elements.

§ Limit shall not be greater than tolerance provided for nonstructural elements. Limit may be exceeded if camber is provided so that total deflection minus camber does not exceed limit.

Table 6.6.3: Minimum Thickness of Slabs without Interior Beams*

f_y, MPa^\dagger	Without drop panels‡			With drop panels‡		
	Exterior panels		Interior panels	Exterior panels		Interior panels
	Without edge beams	With edge beams§		Without edge beams	With edge beams§	
280	$l_n/33$	$l_n/36$	$l_n/36$	$l_n/36$	$l_n/40$	$l_n/40$
420	$l_n/30$	$l_n/33$	$l_n/33$	$l_n/33$	$l_n/36$	$l_n/36$
520	$l_n/28$	$l_n/31$	$l_n/31$	$l_n/31$	$l_n/34$	$l_n/34$

* For two-way construction, l_n is the length of clear span in the long direction, measured face-to-face of supports in slabs without beams and face-to-face of beams or other supports in other cases.

† For f_y between the values given in the table, minimum thickness shall be determined by linear interpolation.

‡ Drop panels as defined in Sec 6.5.2.5.

§ Slabs with beams between columns along exterior edges. The value of α_f for the edge beam shall not be less than 0.8.

6.2.5.3.3 The minimum thickness, h for slabs with beams spanning between the supports on all sides, shall be as follows:

(a) For α_{fm} equal to or less than 0.2, the provisions of Sec 6.2.5.3.2 shall apply;

(b) For α_{fm} greater than 0.2 but not greater than 2.0, h shall not be less than

$$h = \frac{l_n \left(0.8 + \frac{f_y}{1400} \right)}{36 + 5\beta(\alpha_{fm} - 0.2)} \geq 125 \text{ mm} \quad (6.6.5)$$

(c) For α_{fm} greater than 2.0, h shall not be less than

$$h = \frac{l_n \left(0.8 + \frac{f_y}{1400} \right)}{36 + 9\beta} \geq 90 \text{ mm} \quad (6.6.6)$$

(d) An edge beam with a stiffness ratio α_f not less than 0.80 shall be provided at discontinuous edges, or the minimum thickness required by Eq. 6.6.5 or Eq. 6.6.6 shall be increased by at least 10 percent in the panel with a discontinuous edge.

Term l_n in (b) and (c) is length of clear span in long direction measured face-to-face of beams. Term β in (b) and (c) is ratio of clear spans in long to short direction of slab.

6.2.5.3.4 When computed deflections do not exceed the limits of Table 6.6.2, slab thickness less than the minimum required by Sections 6.2.5.3.1 to 6.2.5.3.3 shall be permitted. Deflections shall be computed taking into account size and shape of the panel, conditions of support, and nature of restraints at the panel edges. The modulus of elasticity of concrete, E_c , shall be as specified in Sec 6.1.7.1. The effective moment of inertia, I_e , shall be that given by Eq. 6.6.1; other values shall be permitted to be used if they result in computed deflections in reasonable agreement with results of comprehensive tests. Additional long-term deflection shall be computed in accordance with Sec 6.2.5.2.5.

6.2.5.4 Composite construction

6.2.5.4.1 Shored construction

Where composite flexural members are supported during construction so that, after removal of temporary supports, dead load is resisted by the full composite section, it shall be permitted to consider the composite member equivalent to a monolithically cast member for computation of deflection. For non prestressed members, the portion of the member in compression shall determine whether values in Table 6.6.1 for normal weight or lightweight concrete shall apply. If deflection is computed, account shall be taken of curvatures resulting from differential shrinkage of precast and cast-in-place components, and of axial creep effects in a prestressed concrete member.

6.2.5.4.2 Unshored construction

When the thickness of a non prestressed precast flexural member meets the requirements of Table 6.6.1, deflection need not be computed. If the thickness of a non prestressed composite member meets the requirements of Table 6.6.1, it is not required to compute deflection occurring after the member becomes composite, but the long-term deflection of the precast member shall be investigated for magnitude and duration of load prior to beginning of effective composite action.

6.2.5.4.3 The computed deflection in accordance with Sec 6.2.5.4.1 or Sec 6.2.5.4.2 shall not exceed limits stipulated in Table 6.6.2.

6.3 Axial Loads and Flexure

6.3.1 Scope

The provisions of Sec. 6.3 shall be applicable to the design of members subject to flexure or axial loads or a combination thereof.

6.3.2 Design Assumptions

6.3.2.1 The assumptions given in Sections 6.3.2.2 to 6.3.2.7, and satisfaction of applicable conditions of equilibrium and compatibility of strains shall form the basis of strength design of members for flexure and axial loads.

6.3.2.2 The strains in reinforcement and concrete shall be assumed to be directly proportional to the distance from the neutral axis, except that, for deep beams as defined in Sec 6.3.7.1, an analysis that considers a nonlinear distribution of strain shall be used. Alternatively, it shall be permitted to use a strut-and-tie model. See Sections 6.3.7, 6.4.6, and Appendix I.

6.3.2.3 The maximum usable strain at extreme concrete compression fiber shall be assumed to be 0.003.

6.3.2.4 For stress in reinforcement below f_y , it shall be taken as E_s times steel strain. For strains greater than that corresponding to f_y , stress in reinforcement shall be considered independent of strain and equal to f_y .

6.3.2.5 In axial and flexural calculations of reinforced concrete, the tensile strength of concrete shall be neglected.

6.3.2.6 The relationship between concrete compressive stress distribution and concrete strain shall be assumed to be rectangular, trapezoidal, parabolic, or any other shape that results in prediction of strength in substantial agreement with results of comprehensive tests.

6.3.2.7 An equivalent rectangular concrete stress distribution defined by Sections 6.3.2.7.1 to 6.3.2.7.3 below shall satisfy the requirements of Sec 6.3.2.6.

6.3.2.7.1 Concrete stress of $0.85 f'_c$ shall be assumed uniformly distributed over an equivalent compression zone bounded by edges of the cross section and a straight line located parallel to the neutral axis at a distance $a = \beta_1 c$ from the fibre of maximum compressive strain.

6.3.2.7.2 Distance from the fibre of maximum strain to the neutral axis, c , shall be measured in a direction perpendicular to the neutral axis.

6.3.2.7.3 For f'_c between 17 and 28 MPa, β_1 shall be taken as 0.85. For f'_c above 28 MPa, β_1 shall be reduced linearly at a rate of 0.05 for each 7 MPa of strength in excess of 28 MPa, but β_1 shall not be taken less than 0.65. For f'_c between 28 and 56 MPa, β_1 may be calculated from Eq. 6.6.7.

$$\beta_1 = 0.85 - 0.007143(f'_c - 28) \text{ and } 0.65 \leq \beta_1 \leq 0.85 \quad (6.6.7)$$

6.3.3 General Principles and Requirements

6.3.3.1 Stress and strain compatibility using assumptions in Sec 6.3.2 shall be the basis for design of cross sections subject to flexure or axial loads, or a combination thereof.

6.3.3.2 A cross section shall be considered to be in balanced strain conditions when the tension reinforcement reaches the strain corresponding to f_y just as concrete in compression reaches its assumed ultimate strain of 0.003.

6.3.3.3 Sections are compression-controlled if the net tensile strain in the extreme tension steel, ϵ_t , is equal to or less than the compression-controlled strain limit when the concrete in compression reaches its assumed strain limit of 0.003, Figure 6.6.3. The compression-controlled strain limit is the net tensile strain in the reinforcement at balanced strain conditions. For Grade 420 reinforcement, it shall be permitted to set the compression-controlled strain limit equal to 0.002. For other grades compression-controlled strain limit may be determined by dividing the yield strength by modulus of elasticity E and then rounding the value obtained to four significant digits after the decimal. For example, for Grade 500 reinforcement, the compression-controlled strain limit shall equal to 0.0025.

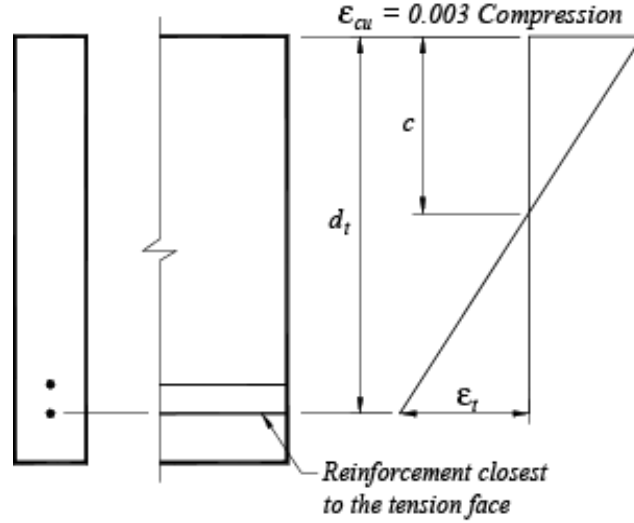


Figure 6.6.3 Strain distribution and net tensile strain

6.3.3.4 Sections are tension-controlled if the net tensile strain in the extreme tension steel, ϵ_t , is equal to or greater than 0.005 when the concrete in compression reaches its assumed strain limit of 0.003. Sections with ϵ_t between the compression-controlled strain limit and 0.005 constitute a transition region between compression-controlled and tension-controlled sections.

6.3.3.5 Net tensile strain in the extreme tension steel at nominal strength, ϵ_t shall not be less than 0.004 for non prestressed flexural members and non prestressed members with factored axial compressive load less than $0.10f'_cA_g$

6.3.3.5.1 Use of compression reinforcement shall be permitted in conjunction with additional tension reinforcement to increase the strength of flexural members.

6.3.3.6 For compression members, design axial strength ϕP_n shall not be taken greater than $\phi P_{n,max}$, computed by Eq. 6.6.8 or Eq. 6.6.9.

6.3.3.6.1 For non prestressed members with spiral reinforcement conforming to Sec. 8.1 or composite members conforming to 6.3.13:

$$\phi P_{n,max} = 0.85\phi[0.85f'_c(A_g - A_{st}) + f_y A_{st}] \quad (6.6.8)$$

6.3.3.6.2 For non prestressed members with tie reinforcement conforming to Sec. 8.1:

$$\phi P_{n,max} = 0.80\phi[0.85f'_c(A_g - A_{st}) + f_y A_{st}] \quad (6.6.9)$$

6.3.3.7 Members subject to compressive axial load shall be designed for the maximum moment that can accompany the axial load. The factored axial force P_u at given eccentricity shall not exceed the value that given in Sec 6.3.3.6. The maximum factored moment M_u shall be magnified for slenderness effects in accordance with Sec 6.3.10.

6.3.4 Spacing of Lateral Supports for Flexural Members

6.3.4.1 Distance between lateral supports for a beam shall not exceed 50 times b , the least width of compression flange or face.

6.3.4.2 Effects of lateral eccentricity of load shall be taken into account in determining spacing of lateral supports.

6.3.5 Minimum Reinforcement for Members in Flexure

6.3.5.1 At every section of a flexural member where tensile reinforcement is required by analysis, except as provided in Sections 6.3.5.2 to 6.3.5.4, A_s provided shall not be less than that given by Equations 6.6.10a and 6.6.10b.

$$A_{s,min} = \frac{0.25\sqrt{f'_c}}{f_y} b_w d \quad (6.6.10a)$$

$$A_{s,min} = \frac{1.4b_w d}{f_y} \quad (6.6.10b)$$

6.3.5.2 For statically determinate members with a flange in tension, $A_{s,min}$ shall not be less than the value given by Equations 6.6.10, except that b_w is replaced by either $2b_w$ or the width of flange, whichever is smaller.

6.3.5.3 If, at every section, A_s provided is at least one-third greater than that required by analysis, the requirements of Sections 6.3.5.1 and 6.3.5.2 need not be applied.

6.3.5.4 For structural slabs and footings including raft that help support the structure vertically of uniform thickness, $A_{s,min}$ in the direction of the span shall be the same as that required by Sec 8.1.11. Maximum spacing of this reinforcement shall not exceed three times the thickness, nor 450 mm.

6.3.6 Distribution of Flexural Reinforcement in One-Way Slabs and Beams

6.3.6.1 Rules for distribution of flexural reinforcement to control flexural cracking in beams and in one-way slabs (slabs reinforced to resist flexural stresses in only one direction) are prescribed in this section.

6.3.6.2 Distribution of flexural reinforcement in two-way slabs shall be as required by Sec 6.5.3.

6.3.6.3 As stated in Sec 6.3.6.4, flexural tension reinforcement shall be well distributed within maximum flexural tension zones of a member cross section.

6.3.6.4 The spacing of reinforcement closest to the tension face, s , shall be less than that given by

$$s = 380 \left(\frac{280}{f_s} \right) - 2.5c_c \quad (6.6.11)$$

But, shall not exceed, $300 \left(\frac{280}{f_s} \right)$ where, c_c is the least distance from surface of reinforcement to the tension face. If there is only one bar or wire nearest to the extreme tension face, s used in Eq. 6.6.11 is the width of the extreme tension face.

Calculated stress f_s in reinforcement closest to the tension face at service load shall be computed based on the unfactored moment. It shall be permitted to take f_s as $\frac{2}{3} f_y$.

6.3.6.5 For structures subject to very aggressive exposure or designed to be watertight, provisions of Sec 6.3.6.4 are not sufficient. For such structures, special investigations and precautions are required.

6.3.6.6 When flanges of T-beam construction are in tension, part of the flexural tension reinforcement shall be distributed over an effective flange width as defined in Sec 6.1.13, or a width equal to one-tenth the span, whichever is smaller. If the effective flange width exceeds one-tenth the span, some longitudinal reinforcement shall be provided in the outer portions of the flange.

6.3.6.7 Longitudinal skin reinforcement shall be uniformly distributed along both side faces of a member (Figure 6.6.4), where h of a beam or joist exceeds 900 mm. Skin reinforcement shall extend for a distance $\frac{h}{2}$ from the tension face. The spacing s shall be as provided in Sec 6.3.6.4, where c_c is the least distance from the surface of the skin reinforcement to the side face. It shall be permitted to include such reinforcement in strength computations if a strain compatibility analysis is made to determine stress in the individual bars or wires.

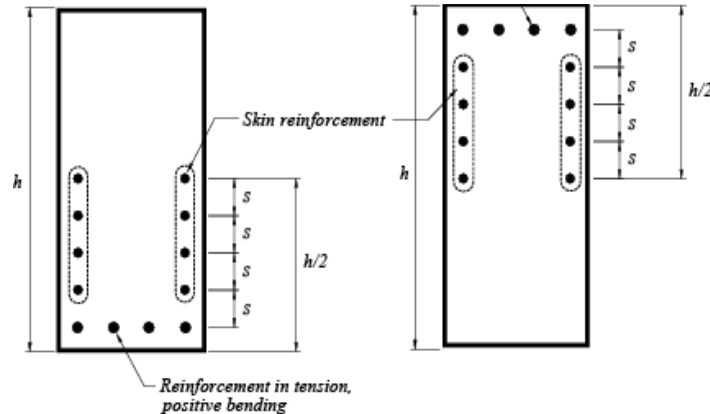


Figure 6.6.4 Skin reinforcement for beams and joists with $h > 900$ mm.

6.3.7 Deep Beams

6.3.7.1 Deep beams are members loaded on one face and supported on the opposite face so that compression struts can develop between the loads and the supports, and have either:

- (a) Clear spans, l_n , equal to or less than four times the overall member depth; or
- (b) Regions with concentrated loads within twice the member depth from the face of the support.

Deep beams shall be designed either taking into account nonlinear distribution of strain, or by Appendix I. (See also Sections 6.4.6.1 and 8.2.7.6) Lateral buckling shall be considered.

6.3.7.2 V_n of deep beams shall be in accordance with Sec 6.4.6.

6.3.7.3 Minimum area of flexural tension reinforcement, $A_{s,min}$, shall conform to Sec 6.3.5.

6.3.7.4 Minimum horizontal and vertical reinforcement in the side faces of deep beams shall satisfy either Sec I.3.3 or Sec 6.4.6.4 and Sec 6.4.6.5.

6.3.8 Design Dimensions for Compression Members

6.3.8.1 Isolated compression member with multiple spirals

Outer limits of the effective cross section of a compression member with two or more interlocking spirals shall be taken at a distance outside the extreme limits of the spirals equal to the minimum concrete cover required by Sec 8.1.7.

6.3.8.2 Monolithically built compression member with wall

Outer limits of the effective cross section of a spirally reinforced or tied reinforced compression member built monolithically with a concrete wall or pier shall be taken not greater than 40 mm outside the spiral or tie reinforcement.

6.3.8.3 Equivalent circular compression member replacing other shapes

In lieu of using the full gross area for design of a compression member with a square, octagonal, or other shaped cross section, it shall be permitted to use a circular section with a diameter equal to the least lateral dimension of the actual shape. Gross area considered, required percentage of reinforcement, and design strength shall be based on that circular section.

6.3.8.4 Limits of section

For a compression member with a cross section larger than required by considerations of loading, it shall be permitted to base the minimum reinforcement and strength on a reduced effective area A_g not less than one-half the total area. This provision shall not apply to special moment frames or special structural walls designed in accordance with Sec. 8.3.

6.3.9 Limits of Reinforcement for Compression Members

6.3.9.1 For noncomposite compression members, the area of longitudinal reinforcement, A_{st} , shall be not less than $0.01A_g$ or more than $0.06A_g$. To avoid practical difficulties in placing and compacting of concrete as well as to deliver ductility to noncomposite compression members, area of longitudinal reinforcement, A_{st} , is preferred not to exceed $0.04A_g$ unless absolutely essential.

6.3.9.2 Minimum number of longitudinal bars in compression members shall be 4 for bars within rectangular or circular ties, 3 for bars within triangular ties, and 6 for bars enclosed by spirals conforming to Sec 6.3.9.3.

6.3.9.3 Volumetric spiral reinforcement ratio, ρ_s , shall be not less than the value given by

$$\rho_s = 0.45 \left(\frac{A_g}{A_{ch}} - 1 \right) \frac{f'_c}{f_{yt}} \quad (6.6.12)$$

Where the value of f_{yt} used in Eq. 6.6.12 shall not exceed 700 MPa. For f_{yt} greater than 420 MPa, lap splices according to 8.1.9.3(e) shall not be used.

6.3.10 Slenderness Effects in Compression Members

6.3.10.1 Slenderness effects shall be permitted to be neglected in the following cases:

- (a) for compression members not braced against side sway when:

$$\frac{kl_u}{r} \leq 22 \quad (6.6.13)$$

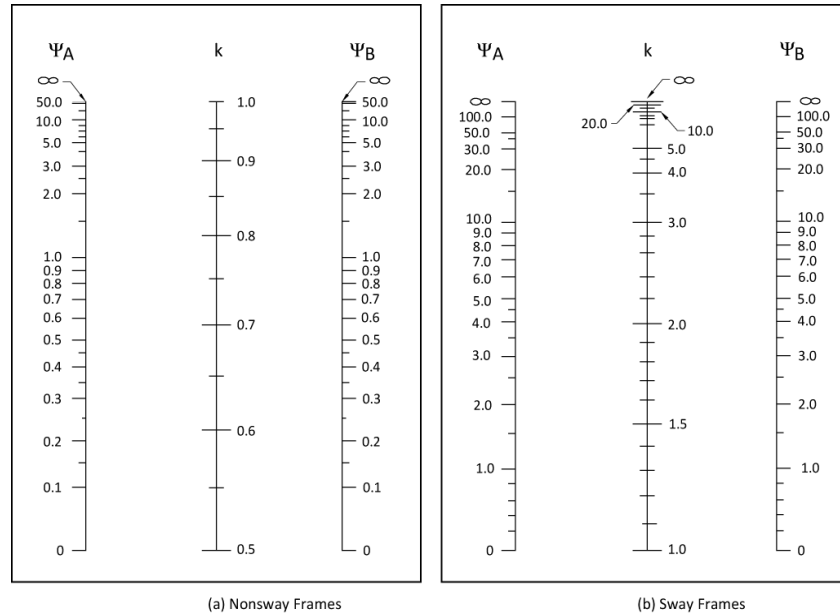
- (b) for compression members braced against side sway when:

$$\frac{kl_u}{r} \leq 34 - 12(M_1/M_2) \leq 40 \quad (6.6.14)$$

Where, M_1/M_2 is positive if the column is bent in single curvature, and negative if the member is bent in double curvature.

Compression members may be considered to be braced against side sway when bracing elements have a total stiffness, resisting lateral movement of that story, of at least 12 times the gross stiffness of the columns within the story.

The Jackson and Moreland Alignment Charts (Figure 6.6.5), which allow a graphical determination of k for a column of constant cross section in a multibay frame may be used as the primary design aid to estimate the effective length factor k .



$\Psi =$ ratio of $\Sigma \left(\frac{EI}{l_c} \right)$ of compression members to $\Sigma \left(\frac{EI}{l} \right)$ of flexural members in plane at one end of a compression member

$l =$ span length of flexural member measured center to center of joints

Figure 6.6.5 Effective length factors k.

6.3.10.1.1 The unsupported length of a compression member, l_u , shall be taken as the clear distance between floor slabs, beams, or other members capable of providing lateral support in the direction being considered. Where column capitals or haunches are present, l_u shall be measured to the lower extremity of the capital or haunch in the plane considered.

6.3.10.1.2 It shall be permitted to take the radius of gyration, r equal to 0.30 times the overall dimension in the direction stability is being considered for rectangular compression members and 0.25 times the diameter for circular compression members. For other shapes, it shall be permitted to compute r for gross concrete section.

6.3.10.2 When slenderness effects are not neglected as permitted by Sec 6.3.10.1, the design of compression members, restraining beams, and other supporting members shall be based on the factored forces and moments from a second-order analysis satisfying Sec 6.3.10.3, Sec 6.3.10.4, or Sec 6.3.10.5. These members shall

also satisfy Sections 6.3.10.2.1 and 6.3.10.2.2. The dimensions of each member cross section used in the analysis shall be within 10 percent of the dimensions of the members shown on the design drawings or the analysis shall be repeated.

6.3.10.2.1 Total moment including second-order effects in compression members, restraining beams, or other structural members shall not exceed 1.4 times the moment due to first-order effects.

6.3.10.2.2 Second-order effects shall be considered along the length of compression members. It shall be permitted to account for these effects using the moment magnification procedure outlined in Sec 6.3.10.6.

6.3.10.3 Nonlinear second-order analysis

Second-order analysis shall consider material nonlinearity, member curvature and lateral drift, duration of loads, shrinkage and creep, and interaction with the supporting foundation. The analysis procedure shall have been shown to result in prediction of strength in substantial agreement with results of comprehensive tests of columns in statically indeterminate reinforced concrete structures.

6.3.10.4 Elastic second-order analysis

Elastic second-order analysis shall consider section properties determined taking into account the influence of axial loads, the presence of cracked regions along the length of the member, and the effects of load duration.

6.3.10.4.1 It shall be permitted to use the following properties for the members in the structure:

- (a) Modulus of elasticity, E_c from Sec 6.1.7.1; (b) Moments of inertia, I as follows; and (c) Area $1.0A_g$

Compression members:	Value of I	Flexural members:	Value of I
Columns	$0.70I_g$	Beams	$0.35I_g$
Walls:		Flat plates and flat slabs	$0.25I_g$
Uncracked	$0.70I_g$		
Cracked	$0.35I_g$		

Alternatively, the moments of inertia of compression and flexural members, I , shall be permitted to be computed as follows:

- (i) Compression members:

$$I = \left(0.80 + 25 \frac{A_{st}}{A_g}\right) \left(1 - \frac{M_u}{P_u h} - 0.5 \frac{P_u}{P_o}\right) I_g \leq 0.875I_g \quad (6.6.15)$$

Where, P_u and M_u shall be determined from the particular load combination under consideration, or the combination of P_u and M_u determined in the smallest value of I . The value of I need not be taken less than $0.35I_g$.

(ii) Flexural members:

$$I = (0.10 + 25\rho) \left(1.2 - 0.2 \frac{b_w}{d}\right) I_g \leq 0.5I_g \quad (6.6.16)$$

For continuous flexural members, I shall be permitted to be taken as the average of values obtained from Eq. 6.6.16 for the critical positive and negative moment sections. The value of I need not be taken less than $0.25I_g$. The cross-sectional dimensions and reinforcement ratio used in the above formulas shall be within 10 percent of the dimensions and reinforcement ratio shown on the design drawings or the stiffness evaluation shall be repeated.

6.3.10.4.2 When sustained lateral loads are present, I for compression members shall be divided by $(1 + \beta_{ds})$. The term β_{ds} shall be taken as the ratio of maximum factored sustained shear within a story to the maximum factored shear in that story associated with the same load combination, but shall not be taken greater than 1.0.

6.3.10.5 Procedure for moment magnification

Columns and stories in structures shall be designated as nonsway or sway columns or stories. The design of columns in nonsway frames or stories shall be based on Sec 6.3.10.6. The design of columns in sway frames or stories shall be based on Sec 6.3.10.7.

6.3.10.5.1 A column in a structure shall be permitted to be assumed as nonsway if the increase in column end moments due to second-order effects does not exceed 5 percent of the first-order end moments.

6.3.10.5.2 A story within a structure is permitted to be assumed as nonsway, if:

$$Q = \frac{\sum P_u \Delta_o}{V_{us} l_c} \leq 0.05 \quad (6.6.17)$$

Where $\sum P_u$ and V_{us} are the total factored vertical load and the horizontal story shear, respectively, in the story being evaluated, and Δ_o is the first-order relative lateral deflection between the top and the bottom of that story due to V_{us} .

6.3.10.6 Procedure for moment magnification - nonsway

Compression members shall be designed for factored axial force P_u and the factored moment amplified for the effects of member curvature M_c where

$$M_c = \delta_{ns} M_2 \quad (6.6.18)$$

Where,

$$\delta_{ns} = \frac{C_m}{1 - \frac{P_u}{0.75P_c}} \geq 1.0 \quad (6.6.19)$$

And,

$$P_c = \frac{\pi^2 EI}{(kl_u)^2} \quad (6.6.20)$$

6.3.10.6.1 EI shall be taken as

$$EI = \frac{(0.2E_c I_g + E_s I_{se})}{1 + \beta_{dns}} \quad (6.6.21)$$

Or,

$$EI = \frac{0.4E_c I_g}{1 + \beta_{dns}} \quad (6.6.22)$$

Alternatively, EI shall be permitted to compute the value of I from Equation 6.6.15 dividing by $(1 + \beta_{dns})$.

6.3.10.6.2 The term β_{dns} shall be taken as the ratio of maximum factored axial sustained load to maximum factored axial load associated with the same load combination, but shall not be taken greater than 1.0.

6.3.10.6.3 The effective length factor, k shall be permitted to be taken as 1.0.

6.3.10.6.4 For members with no transverse load between supports, C_m shall be taken as

$$C_m = 0.6 + 0.4 \frac{M_1}{M_2} \quad (6.6.23)$$

Where, M_1/M_2 is positive if the column is bent in single curvature, and negative if the member is bent in double curvature. For members with transverse loads between supports, C_m shall be taken as 1.0.

6.3.10.6.5 Factored moment, M_2 , about each axis separately, in Equation 6.6.18 shall not be taken less than

$$M_{2,min} = P_u (15 + 0.03h) \quad (6.6.24)$$

Where, h is in mm and P_u in N. For members in which $M_{2,min}$ exceeds M_2 , the value of C_m in Equation 6.6.23 shall either be taken equal to 1.0, or shall be based on the ratio of the computed end moments, M_1/M_2 .

6.3.10.7 Procedure for moment magnification - Sway

Moments M_1 and M_2 at the ends of an individual compression member shall be taken as

$$M_1 = M_{1ns} + \delta_s M_{1s} \quad (6.6.25)$$

$$M_2 = M_{2ns} + \delta_s M_{2s} \quad (6.6.26)$$

Where, δ_s is computed according to Sec 6.3.10.7.3 or Sec 6.3.10.7.4.

6.3.10.7.1 Flexural members shall be designed for the total magnified end moments of the compression members at the joint.

6.3.10.7.2 The values of E_c and I given in Sec 6.3.10.4 shall be used for determining the effective length factor K and it shall not be less than 1.0.

6.3.10.7.3 The moment magnifier δ_s shall be calculated as

$$\delta_s = \frac{1}{1-Q} \geq 1 \quad (6.6.27)$$

If δ_s calculated by Equation 6.6.27 exceeds 1.5, δ_s shall be calculated using second-order elastic analysis or 6.3.10.7.4.

6.3.10.7.4 Alternatively, it shall be permitted to calculate δ_s as

$$\delta_s = \frac{1}{1 - \frac{\sum P_u}{0.75 \sum P_c}} \geq 1 \quad (6.6.28)$$

Where, $\sum P_u$ is the summation for all the factored vertical loads in a story and $\sum P_c$ is the summation for all sway-resisting columns in a storey. P_c is calculated using Equation 6.6.20 with k determined from Sec 6.3.10.7.2 and EI from Sec 6.3.10.6.1.

6.3.11 Axially Loaded Members Supporting Slab System

Axially loaded members supporting a slab system included within the scope of Sec 6.5.1 shall be designed as provided in Sec. 6.3 and in accordance with the additional requirements of Sec. 6.5.

6.3.12 Column Load Transmission through Floor System

If f'_c of a column is greater than 1.4 times that of the floor system, transmission of load through the floor system shall be provided by Sections 6.3.12.1, 6.3.12.2, or 6.3.12.3.

6.3.12.1 Concrete of strength specified for the column shall be placed in the floor at the column location. Top surface of the column concrete shall extend 600 mm into the slab from face of column. Column concrete shall be well integrated with floor concrete, and shall be placed in accordance with relevant provisions for construction joints of columns, walls etc. with beams, slabs etc. To avoid accidental placing of lower strength concrete in the columns, the structural designer shall indicate on the drawing where the high and low strength concretes are to be placed.

6.3.12.2 Strength of a column through a floor system shall be based on the lower value of concrete strength with vertical dowels and spirals as required.

6.3.12.3 For columns laterally supported on four sides by beams of approximately equal depth or by slabs, it shall be permitted to base strength of the column on an assumed concrete strength in the column joint equal to 75 percent of column concrete strength plus 35 percent of floor concrete strength. In the application of Sec 6.3.12.3, ratio of column concrete strength to slab concrete strength shall not be taken larger than 2.5 in design.

6.3.13 Composite Compression Members

6.3.13.1 All members reinforced longitudinally with structural steel shapes, pipe, or tubing with or without longitudinal bars shall be included in composite compression members.

6.3.13.2 A composite member strength shall be computed for the same limiting conditions applicable to ordinary reinforced concrete members.

6.3.13.3 Any axial load strength assigned to concrete of a composite member shall be transferred to the concrete by members or brackets in direct bearing on the composite member concrete.

6.3.13.4 All axial load strength not assigned to concrete of a composite member shall be developed by direct connection to the structural steel shape, pipe, or tube.

6.3.13.5 For evaluation of slenderness effects, radius of gyration, r , of a composite section shall be not greater than the value given by

$$r = \sqrt{\frac{(E_c I_g / 5) + E_s I_{sx}}{(E_c A_g / 5) + E_s A_{sx}}} \quad (6.6.29)$$

And, as an alternative to a more accurate calculation, EI in Equation 6.6.20 shall be taken either as Equation 6.6.21 or

$$EI = \frac{(E_c I_g / 5)}{1 + \beta_d} + E_s I_{sx} \quad (6.6.30)$$

6.3.13.6 Concrete core encased by structural steel

6.3.13.6.1 When a composite member is a structural steel encased concrete core,

the thickness of the steel encasement shall be not less than $b \sqrt{\frac{f_y}{3E_s}}$ for each face of

width b nor $b \sqrt{\frac{f_y}{8E_s}}$ for circular sections of diameter h

6.3.13.6.2 When computing A_{sx} and I_{sx} , longitudinal bars located within the encased concrete core shall be permitted to be used.

6.3.13.7 Spiral reinforcement around structural steel core

A composite member with spirally reinforced concrete around a structural steel core shall conform to Sections 6.3.13.7.1 to 6.3.13.7.4.

6.3.13.7.1 Design yield strength of structural steel core shall be the specified minimum yield strength for the grade of structural steel used but not to exceed 350 MPa.

6.3.13.7.2 Spiral reinforcement shall conform to Sec 6.3.9.3.

6.3.13.7.3 Longitudinal bars located within the spiral shall be not less than 0.01 nor more than 0.06 times net area of concrete section.

6.3.13.7.4 Longitudinal bars located within the spiral shall be permitted to be used in computing A_{sx} and I_{sx} .

6.3.13.8 Tie reinforcement around structural steel core

Laterally tied concrete around a structural steel core forming a composite member shall conform to Sections 6.3.13.8.1 to 6.3.13.8.7.

6.3.13.8.1 Design yield strength of structural steel core shall be the specified minimum yield strength for the grade of structural steel used but not to exceed 350 MPa.

6.3.13.8.2 Lateral ties shall extend completely around the structural steel core.

6.3.13.8.3 Lateral ties shall have a diameter not less than 0.02 times the greatest side dimension of composite member, except that ties shall not be smaller than 10 mm diameter and are not required to be larger than 16 mm diameter. Welded wire reinforcement of equivalent area shall be permitted.

6.3.13.8.4 Vertical spacing of lateral ties shall not exceed 16 longitudinal bar diameters, 48 tie bar diameters, or 0.5 times the least side dimension of the composite member.

6.3.13.8.5 Longitudinal bars located within the ties shall be not less than 0.01 nor more than 0.06 times net area of concrete section.

6.3.13.8.6 A longitudinal bar shall be located at every corner of a rectangular cross section, with other longitudinal bars spaced not farther apart than one half the least side dimension of the composite member.

6.3.13.8.7 Longitudinal bars located within the ties shall be permitted to be used in computing A_{sx} and I_{sx} .

6.3.14 Bearing strength

6.3.14.1 Design bearing strength of concrete shall not exceed $\phi(0.85f'_cA_1)$, except when the supporting surface is wider on all sides than the loaded area, then the design bearing strength of the loaded area shall be permitted to be multiplied by $\sqrt{A_2 / A_1}$ but by not more than 2 Figure. 6.6.6.

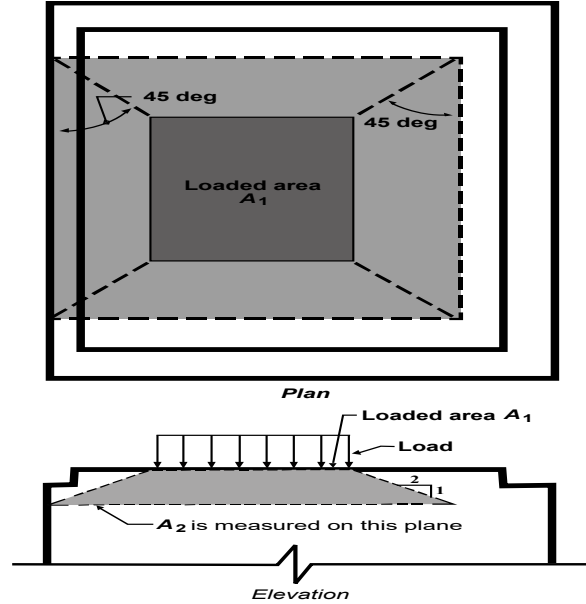


Figure 6.6.6 Determination of area A_2 in stepped or sloped supports using frustum

6.3.15 Design for Flexure

6.3.15.1 Design of Rectangular Beams

- (a) Formula for singly reinforced beams: The following equations which are based on the simplified stress block of Sec 6.3.2.7, are applicable to singly reinforced rectangular beams along with T-beams where the neutral axis lies within the flange.

$$A_s = \frac{M_n}{f_y(d-a/2)} \quad (6.6.31)$$

Where,

$$a = \frac{A_s f_y}{0.85 f'_c b} \quad (6.6.32)$$

By estimating an initial value of a , Equation 6.6.31 can be used to determine an approximate value of A_s . The value can be substituted in Equation 6.6.32 to get a better estimate of a and hence a new $(d - \frac{a}{2})$ can be determined for substitution in Equation 6.6.31.

In Equation 6.6.31, a preliminary value of nominal flexural strength of section, M_n may be taken as factored moment at section, M_u divided by strength reduction factor, $\phi = 0.9$. Reinforcement ratio, $\rho = A_s/bd$ calculated on the basis of A_s determined from Equation 6.6.31 shall not exceed ρ_{max} , where

$$\rho_{max} = 0.85\beta_1 \frac{f'_c}{f_y} \frac{\epsilon_u}{\epsilon_u + 0.004} \quad (6.6.33)$$

and, $\epsilon_u = 0.003$

Additionally, A_s determined from Equation 6.6.31 shall have to satisfy the requirements of minimum reinforcement for members in flexure as per Sec 6.3.5.

Revised ϕ shall be determined from Sec 6.2.3.2 based on either $c/d_t = a/\beta_1 d_t$ or ϵ_t , where, ϵ_t is the net tensile strain in the reinforcement furthest from the compression face of the concrete at the depth d_t . Strain, ϵ_t may be calculated from Equation 6.6.33 by replacing 0.004 by ϵ_t and ρ_{max} by ρ respectively.

- (b) Design formulae for doubly reinforced beams: A doubly reinforced beam shall be designed only when there is a restriction on depth of beam and maximum tensile reinforcement allowed cannot produce the required moment M_u .

To establish if doubly reinforced beam is required the following approach can be followed:

Determine,

$$\rho_{0.005} = 0.85\beta_1 \frac{f'_c}{f_y} \frac{\epsilon_u}{\epsilon_u + 0.005} \quad (6.6.34)$$

$$A_s = \rho_{0.005} b d$$

$$a = \frac{A_s f_y}{0.85 f'_c b}$$

$$\phi M_n = \phi A_s f_y \left(d - \frac{a}{2} \right) \quad (6.6.35)$$

If ϕM_n is less than required moment M_u with $\phi = 0.9$, a doubly reinforced beam is needed and then taking values of A_s and ϕM_n from above, put

$$A_{s1} = A_s \text{ and } \phi M_{n1} = \phi M_n$$

Then, the following values are to be evaluated,

$$\phi M_{n2} = M_u - \phi M_{n1} \quad (6.6.36)$$

$$A_{s2} = \frac{\phi M_{n2}}{\phi f_y (d - d')}$$

Assuming compression steel yields (needs to be checked later),

$$A'_s = A_{s2}$$

$$A_s = A_{s1} + A_{s2}$$

Check $\rho \geq \bar{\rho}_{cy}$ for compression steel yielding, where

$$\bar{\rho}_{cy} = 0.85\beta_1 \frac{f'_c d'}{f_y d} \frac{\epsilon_u}{\epsilon_u - \epsilon_y} + \rho' \quad (6.6.37)$$

If $\rho \geq \bar{\rho}_{cy}$ (i.e. compression steel yields),

Find $a = \frac{(A_s - A'_s)f_y}{0.85f'_c b}$ and find c , ϵ_t and confirm $\phi = 0.9$ in the above equations. Value of ϕ shall be determined from Sec 6.2.3.2 based on either $c/d_t = a/\beta_1 d_t$ or ϵ_t , as stated above for rectangular beams.

If compression steel does not yield, c is to be found from concrete section force equilibrium condition, C=T which will result in a quadratic equation of c . f'_s needs to be calculated from strain diagram and A'_s revised.

$$A'_s = A_{s2} \frac{f_y}{f'_s}$$

$$A_s = A_{s1} + A_{s2}$$

ϵ_t shall be calculated from c for finding ϕ .

6.3.15.2 Design of T-Beams

- (a) General: For effective widths and other parameters for T, L or isolated beams, Sections 6.1.13.2 to 6.1.13.4 shall apply.
- (b) Formulae for T-beams : A T-beam shall be treated as a rectangular beam if $a \leq h_f$ where a is obtained from Eq. 6.6.32. In using Eq. 6.6.32, if A_s is not known, it may be initially assumed as :

$$A_s = \frac{M_n}{f_y(d - h_f/2)} \quad (6.6.38)$$

If a , thus obtained, is greater than h_f the beam shall be considered as a T-beam, in which case the following formulae shall be applicable :

$$A_{sf} = \frac{0.85f'_c(b - b_w)h_f}{f_y} \quad (6.6.39)$$

$$M_{n1} = A_{sf}f_y(d - h_f/2) \quad (6.6.40)$$

$$M_{n2} = M_n - M_{n1} \quad (6.6.41)$$

$$A_s - A_{sf} = \frac{M_{n2}}{f_y(d - a/2)} \quad (6.6.42)$$

$$a = \frac{(A_s - A_{sf})f_y}{0.85f'_c b_w} \quad (6.6.43)$$

By estimating an initial value of a , Eq. 6.6.42 can be used to obtain an approximate value of $(A_s - A_{sf})$. That value of $(A_s - A_{sf})$ can be substituted in Eq. 6.6.43 to get a better estimate of a .

Net tensile strain requirements will be satisfied as long as depth to neutral axis, $c \leq 0.429 d_t$. This will occur if:

$$\rho_w < \rho_{w,max}$$

Where,

$$\rho_w = \frac{A_s}{b_w d} \quad (6.6.44)$$

$$\rho_{w,max} = \rho_{max} + \rho_f \quad (6.6.45)$$

$$\rho_f = \frac{A_{sf}}{b_w d} \quad (6.6.46)$$

and, ρ_{max} is as defined by Eq. 6.6.33. For c/d_t ratios between 0.429 and 0.375, equivalent to ρ_w between the $\rho_{w,max}$ from Eq. 6.6.45 and $\rho_{w,max}$ calculated by substituting ρ from Eq. 6.6.33 with 0.005 in place of 0.004 and ρ for ρ_{max} , the strength reduction factor, ϕ must be adjusted for ε_t in accordance with Sec 6.2.3.2.

6.4 Shear and Torsion

6.4.1 Shear Strength

6.4.1.1 Except for members designed in accordance with Appendix I, design of cross sections subject to shear shall be based on

$$\phi V_n \geq V_u \quad (6.6.47)$$

Where, V_u is the factored shear force at the section considered and V_n is nominal shear strength given by

$$V_n = V_c + V_s \quad (6.6.48)$$

Where, V_c is nominal shear strength provided by concrete calculated in accordance with Sec 6.4.2, or Sec 6.4.10, and V_s is nominal shear strength provided by shear reinforcement calculated in accordance with Sec 6.4.3, Sec 6.4.8.9, or Sec 6.4.10.

6.4.1.1.1 The effect of any openings in members shall be considered in determining V_n .

6.4.1.1.2 In evaluating V_c , whenever applicable, effects of axial tension due to creep and shrinkage in restrained members shall be considered and effects of inclined flexural compression in variable depth members shall be permitted to be included.

6.4.1.2 Except as allowed in Sec 6.4.1.2.1, the values of $\sqrt{f_c}$ used in this Chapter shall not exceed 8.3 MPa.

6.4.1.2.1 Values of $\sqrt{f'_c}$ greater than 8.3 MPa shall be permitted in computing V_c , V_{ci} , and V_{cw} for reinforced concrete beams and concrete joist construction having minimum web reinforcement in accordance with Sec 6.4.3.5.3, or Sec 6.4.4.5.2.

6.4.1.3 Computation of maximum V_u at supports in accordance with Sec 6.4.1.3.1 shall be permitted if all conditions (a), (b), and (c) are satisfied:

- (a) Support reaction, in direction of applied shear, introduces compression into the end regions of member;
- (b) Loads are applied at or near the top of the member;
- (c) No concentrated load occurs between face of support and location of critical section defined in Sec 6.4.1.3.1.

6.4.1.3.1 Sections located less than a distance d from face of support shall be permitted to be designed for V_u computed at a distance d .

6.4.1.4 For deep beams, brackets and corbels, walls, and slabs and footings, the special provisions of Sections 6.4.6 to 6.4.10 shall apply.

6.4.2 Contribution of Concrete to Shear Strength

6.4.2.1 V_c shall be computed by provisions of Sections 6.4.2.1.1 to 6.4.2.1.3, unless a more detailed calculation is made in accordance with Sec 6.4.2.2. Throughout this Chapter, except in Sec 6.4.5, λ shall be as defined in Sec 6.1.8.1.

6.4.2.1.1 For members subject to shear and flexure only,

$$V_c = 0.17\lambda\sqrt{f'_c}b_wd \quad (6.6.49)$$

6.4.2.1.2 For members subject to axial compression,

$$V_c = 0.17\left(1 + \frac{N_u}{14A_g}\right)\lambda\sqrt{f'_c}b_wd \quad (6.6.50)$$

Quantity N_u/A_g shall be expressed in MPa.

6.4.2.1.3 For members subject to significant axial tension, V_c shall be taken as zero unless a more detailed analysis is made using Sec 6.4.2.2.3.

6.4.2.2 V_c shall be permitted to be computed by more detailed calculation of Sections 6.4.2.2.1 to 6.4.2.2.3.

6.4.2.2.1 For members subject to shear and flexure only,

$$V_c = \left(0.16\lambda\sqrt{f'_c} + 17\rho_w\frac{V_u d}{M_u}\right)b_wd \quad (6.6.51)$$

But, not greater than $0.29\lambda\sqrt{f'_c}b_wd$. When computing V_c by Eq. 6.6.51, $V_u d/M_u$ shall not be taken greater than 1.0, where M_u occurs simultaneously with V_u at section considered.

6.4.2.2.2 For members subject to axial compression, it shall be permitted to compute V_c using Eq. 6.6.51 with M_m substituted for M_u and $V_u d/M_u$ not then limited to 1.0, where

$$M_m = M_u - N_u \frac{(4h-d)}{8} \quad (6.6.52)$$

However, V_c shall not be taken greater than

$$V_c = 0.29\lambda\sqrt{f'_c}b_wd \sqrt{1 + \frac{0.29N_u}{A_g}} \quad (6.6.53)$$

N_u/A_g shall be expressed in MPa. When M_m as computed by Eq. 6.6.52 is negative, V_c shall be computed by Eq. 6.6.53.

6.4.2.2.3 For members subject to significant axial tension,

$$V_c = 0.17(1 + \frac{0.29N_u}{A_g})\lambda\sqrt{f'_c}b_wd \quad (6.6.54)$$

But, not less than zero, where N_u is negative for tension. N_u/A_g shall be expressed in MPa.

6.4.2.3 For circular members, the area used to compute V_c shall be taken as the product of the diameter and effective depth of the concrete section. It shall be permitted to take d as 0.80 times the diameter of the concrete section.

6.4.3 Shear Strength Contribution of Reinforcement

6.4.3.1 Types of shear reinforcement

6.4.3.1.1 The following types of shear reinforcement shall be permitted:

- (a) Stirrups perpendicular to axis of member;
- (b) Welded wire reinforcement with wires located perpendicular to axis of member;
- (c) Spirals, circular ties, or hoops.
- (d) Stirrups making an angle of 45° or more with longitudinal tension reinforcement;
- (e) Longitudinal reinforcement with bent portion making an angle of 30° or more with the longitudinal tension reinforcement;
- (f) Combinations of stirrups and bent longitudinal reinforcement.

6.4.3.2 The values of f_y and f_{yt} used in design of shear reinforcement shall not exceed 420 MPa, except the value shall not exceed 550 MPa for welded deformed wire reinforcement.

6.4.3.3 Stirrups and other bars or wires used as shear reinforcement shall extend to a distance d from extreme compression fiber and shall be developed at both ends according to Sec 8.2.10.

6.4.3.4 Limits in spacing for shear reinforcement

6.4.3.4.1 Spacing of shear reinforcement placed perpendicular to member axis shall not exceed $\frac{d}{2}$ nor 600 mm.

6.4.3.4.2 The spacing of inclined stirrups and bent longitudinal reinforcement shall be such that every 45-degree line, extending toward the reaction from mid-depth of member $\frac{d}{2}$ to longitudinal tension reinforcement, shall be crossed by at least one line of shear reinforcement.

6.4.3.4.3 Where, V_s exceeds $0.33\sqrt{f'_c b_w d}$ maximum spacing given in Sections 6.4.3.4.1 and 6.4.3.4.2 shall be reduced by one-half.

6.4.3.5 Minimum shear reinforcement

6.4.3.5.1 A minimum area of shear reinforcement, $A_{v,min}$, shall be provided in all reinforced concrete flexural members, where V_u exceeds $0.5\phi V_c$, except in members satisfying one or more of (a) to (f):

- (a) Footings and solid slabs;
- (b) Hollow-core units with total untopped depth not greater than 315 mm and hollow-core units where V_u is not greater than $0.5\phi V_{cw}$;
- (c) Concrete joist construction defined by Sec 6.1.14;
- (d) Beams with h not greater than 250 mm;
- (e) Beam integral with slabs with h not greater than 600 mm and not greater than the larger of 2.5 times thickness of flange, and 0.5 times width of web;
- (f) Beams constructed of steel fiber-reinforced, normal weight concrete with f'_c not exceeding 40 MPa, h not greater than 600 mm, and V_u not greater than $0.17\phi\sqrt{f'_c}b_w d$.

6.4.3.5.2 Minimum shear reinforcement requirements of Sec 6.4.3.5.1 shall be permitted to be waived if shown by test that required M_n and V_n can be developed when shear reinforcement is omitted. Such tests shall simulate effects of differential

settlement, creep, shrinkage, and temperature change, based on a realistic assessment of such effects occurring in service.

6.4.3.5.3 Where shear reinforcement is required by Sec 6.4.3.5.1 or for strength and where Sec 6.4.4.1 allows torsion to be neglected, $A_{v,min}$ shall be computed by

$$A_{v,min} = 0.062 \sqrt{f'_c} \frac{b_w s}{f_{yt}} \quad (6.6.55)$$

But, shall not be less than $(0.35b_w s)/f_{yt}$.

6.4.3.6 Design of shear reinforcement

6.4.3.6.1 Where V_u exceeds ϕV_c , shear reinforcement shall be provided to satisfy Equations 6.6.47 and 6.6.48, where V_s shall be computed in accordance with Sections 6.4.3.6.2 to 6.4.3.6.9.

6.4.3.6.2 Where shear reinforcement perpendicular to axis of member is used,

$$V_s = \frac{A_v f_{yt} d}{s} \quad (6.6.56)$$

Where, A_v is the area of shear reinforcement within spacing s .

6.4.3.6.3 Where circular ties, hoops, or spirals are used as shear reinforcement, V_s shall be computed using Eq. 6.6.56 where d is defined in Sec 6.4.2.3 for circular members, A_v shall be taken as two times the area of the bar in a circular tie, hoop, or spiral at a spacing S , s is measured in a direction parallel to longitudinal reinforcement, and f_{yt} is the specified yield strength of circular tie, hoop, or spiral reinforcement.

6.4.3.6.4 Where inclined stirrups are used as shear reinforcement,

$$V_s = \frac{A_v f_{yt} (\sin \alpha + \cos \alpha) d}{s} \quad (6.6.57)$$

Where, α is angle between inclined stirrups and longitudinal axis of the member, and s is measured in direction parallel to longitudinal reinforcement.

6.4.3.6.5 Where shear reinforcement consists of a single bar or a single group of parallel bars, all bent up at the same distance from the support,

$$V_s = A_v f_y \sin \alpha \quad (6.6.58)$$

But, not greater than $0.25\sqrt{f'_c} b_w d$, where α is angle between bent-up reinforcement and longitudinal axis of the member.

6.4.3.6.6 Where shear reinforcement consists of a series of parallel bent-up bars or groups of parallel bent-up bars at different distances from the support, V_s shall be computed by Eq. 6.6.57.

6.4.3.6.7 Only the center three-fourths of the inclined portion of any longitudinal bent bar shall be considered effective for shear reinforcement.

6.4.3.6.8 Where more than one type of shear reinforcement is used to reinforce the same portion of a member, V_s shall be computed as the sum of the values computed for the various types of shear reinforcement.

6.4.3.6.9 V_s shall not be taken greater than $0.66\sqrt{f'_c d_w d}$.

6.4.4 Design for Torsion

Design for torsion shall be done as per Sections 6.4.4.1 to 6.4.4.6. A beam subjected to torsion is idealized as a thin-walled tube with the core concrete cross section in a solid beam neglected as shown in Figure 6.6.7.

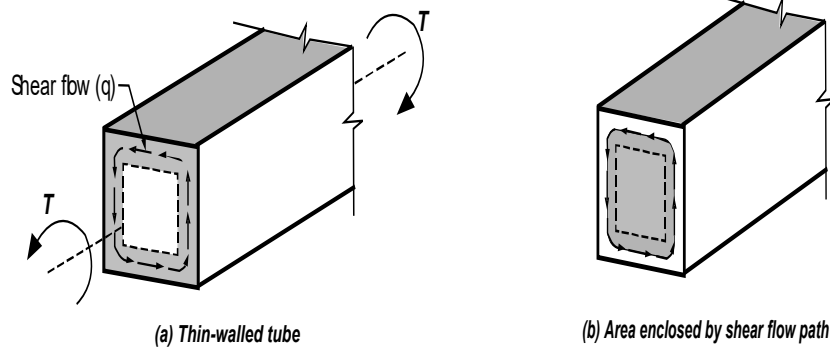


Figure 6.6.7 (a) Torsional resistance by thin-walled tube; (b) Ineffective inner area enclosed by shear flow path

6.4.4.1 Threshold torsion

It shall be permitted to neglect torsion effects if the factored torsional moment T_u is less than:

- (a) For members not subjected to axial tension or compression

$$0.083\phi\lambda\sqrt{f'_c}\left(\frac{A_{cp}^2}{p_{cp}}\right)$$

- (b) For members subjected to an axial compressive or tensile force

$$0.083\phi\lambda\sqrt{f'_c}\left(\frac{A_{cp}^2}{p_{cp}}\right)\sqrt{1 + \frac{N_u}{0.33A_g\lambda\sqrt{f'_c}}}$$

The overhanging flange width used in computing A_{cp} and p_{cp} for members cast monolithically with a slab shall conform to Sec 6.5.2.4. For a hollow section, A_g shall be used in place of A_{cp} in Sec 6.4.4.1, and the outer boundaries of the section shall conform to Sec 6.5.2.4.

6.4.4.1.1 For members cast monolithically with a slab and for isolated members with flanges, the overhanging flange width used to compute A_{cp} and P_{cp} shall conform to Sec 6.5.2.4, except that the overhanging flanges shall be neglected in cases where the parameter A_{cp}^2 / P_{cp} calculated for a beam with flanges is less than that computed for the same beam ignoring the flanges.

6.4.4.2 Evaluation of factored torsional moment

6.4.4.2.1 If the factored torsional moment, T_u , in a member is required to maintain equilibrium Figure 6.6.8 and exceeds the minimum value given in Sec 6.4.4.1, the member shall be designed to carry T_u in accordance with Sections 6.4.4.3 to 6.4.4.6.

6.4.4.2.2 In a statically indeterminate structure where reduction of the torsional moment in a member can occur due to redistribution of internal forces upon cracking Figure 6.6.9, the maximum T_u shall be permitted to be reduced to the values given in (a), or (b) as applicable:

- (a) For members, at the sections described in Sec 6.4.4.2.4 and not subjected to axial tension or compression

$$0.33\phi\lambda\sqrt{f'_c}\left(\frac{A_{cp}^2}{p_{cp}}\right)$$

- (b) For members subjected to an axial compressive or tensile force

$$0.33\phi\lambda\sqrt{f'_c}\left(\frac{A_{cp}^2}{p_{cp}}\right)\sqrt{1 + \frac{N_u}{0.33A_g\lambda\sqrt{f'_c}}}$$

In (a), or (b), the correspondingly redistributed bending moments and shears in the adjoining members shall be used in the design of these members. For hollow sections, A_{cp} shall not be replaced with A_g in Sec 6.4.4.2.2.

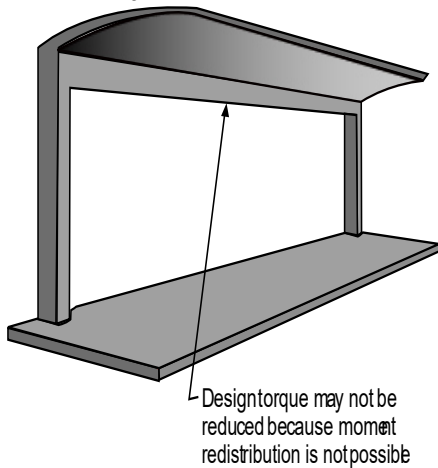


Figure 6.6.8 Design torque may not be reduced

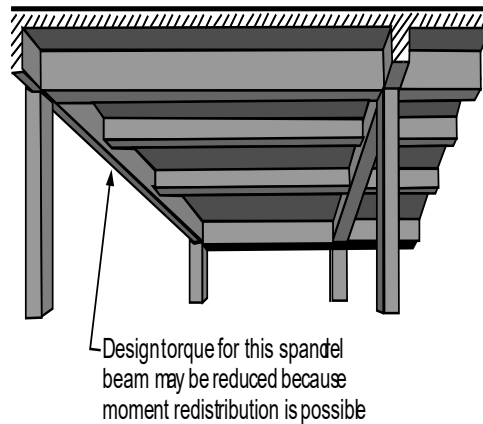


Figure 6.6.9 Design torque may be reduced

6.4.4.2.3 It shall be permitted to take the torsional loading from a slab as uniformly distributed along the member, if not determined by a more exact analysis.

6.4.4.2.4 Sections located closer than a distance d from the face of a support shall be designed for not less than T_u computed at a distance d . If a concentrated torque occurs within this distance, the critical section for design shall be at the face of the support.

6.4.4.3 Torsional moment strength

6.4.4.3.1 The cross-sectional dimensions shall be such that:

(a) For solid sections

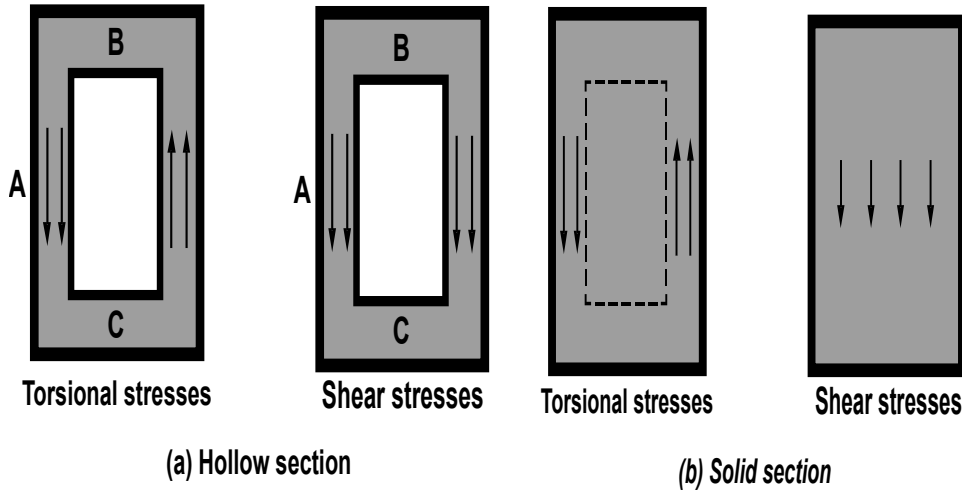
$$\sqrt{\left(\frac{V_u}{b_w d}\right)^2 + \left(\frac{T_u P_h}{1.7 A_{oh}^2}\right)^2} \leq \phi \left(\frac{V_c}{b_w d} + 0.66 \sqrt{f'_c}\right) \quad (6.6.59)$$

(b) For hollow sections

$$\left(\frac{V_u}{b_w d}\right) + \left(\frac{T_u P_h}{1.7 A_{oh}^2}\right) \leq \phi \left(\frac{V_c}{b_w d} + 0.66 \sqrt{f'_c}\right) \quad (6.6.60)$$

Superposition of shear stresses due to shear and torsion in hollow sections given by the left side of the inequality Sec 6.4.14 is illustrated by Figure 6.6.10(a) and that in solid sections given by the left side of the inequality Sec 6.4.13 is illustrated by Figure 6.6.10(b).

6.4.4.3.2 If the wall thickness varies around the perimeter of a hollow section, Eq. 6.6.60 shall be evaluated at the location where the left-hand side of Eq. 6.6.60 is a maximum.



(a) Hollow section

(b) Solid section

Figure 6.6.10 Superposition of torsional and shear stresses

6.4.4.3.3 If the wall thickness is less than A_{oh} / p_h , the second term in Eq. 6.4.14

shall be taken as $\left(\frac{T_u}{1.7A_{oh}t} \right)$

Where, t is the thickness of the wall of hollow section at the location where the stresses are being checked.

6.4.4.3.4 The values of f_y and f_{yt} used for design of torsional reinforcement shall not exceed 420 MPa.

6.4.4.3.5 Where T_u exceeds the threshold torsion, design of the cross section shall be based on

$$\phi T_n \geq T_u \quad (6.6.61)$$

6.4.4.3.6 T_u shall be computed by

$$T_n = \frac{2A_oA_t f_{yt}}{s} \cot \theta \quad (6.6.62)$$

Where, A_o shall be determined by analysis except that it shall be permitted to take A_o equal to $0.85A_{oh}$; θ shall not be taken smaller than 30° nor larger than 60° . It shall be permitted to take θ equal to 45° .

6.4.4.3.7 The additional area of longitudinal reinforcement to resist torsion, A_l , shall not be less than

$$A_l = \frac{A_t}{s} p_h \left(\frac{f_{yt}}{f_y} \right) \cot^2 \theta \quad (6.6.63)$$

Where, θ shall be the same value used in Eq. 6.6.62 and A_t/s shall be taken as the amount computed from Eq. 6.6.62 not modified in accordance with Sec 6.4.4.5.2 or Sec 6.4.4.5.3; f_{yt} refers to closed transverse torsional reinforcement, and f_y refers to longitudinal torsional reinforcement.

6.4.4.3.8 Reinforcement required for torsion shall be added to that required for the shear, moment, and axial force that act in combination with the torsion. The most restrictive requirements for reinforcement spacing and placement shall be met.

6.4.4.3.9 It shall be permitted to reduce the area of longitudinal torsion reinforcement in the flexural compression zone by an amount equal to, $M_u / (0.9df_y)$, where M_u occurs at the section simultaneously with T_u , except that the reinforcement provided shall not be less than that required by Sec 6.4.4.5.3 or Sec 6.4.4.6.2.

6.4.4.4 Details of torsional reinforcement

6.4.4.4.1 Torsion reinforcement shall consist of longitudinal bars or tendons and one or more of the following:

- (a) Closed stirrups or closed ties, perpendicular to the axis of the member;
- (b) A closed cage of welded wire reinforcement with transverse wires perpendicular to the axis of the member;
- (c) Spiral reinforcement.

6.4.4.4.2 Transverse torsional reinforcement shall be anchored by one of the following:

- (a) A 135° standard hook, or seismic hook as defined in Sec 8.1.2.1(d) Chapter 8, around a longitudinal bar;
- (b) According to Sec 8.2.10.2 Chapter 8 in regions where the concrete surrounding the anchorage is restrained against spalling by a flange or slab or similar member.

6.4.4.4.3 Longitudinal torsion reinforcement shall be developed at both ends.

6.4.4.4.4 For hollow sections in torsion, the distance from the centerline of the transverse torsional reinforcement to the inside face of the wall of the hollow section shall not be less than $0.5 A_{oh} / P_h$.

6.4.4.5 Minimum torsion reinforcement

6.4.4.5.1 A minimum area of torsional reinforcement shall be provided in all regions, where T_u exceeds the threshold torsion given in Sec 6.4.4.1.

6.4.4.5.2 Where torsional reinforcement is required by Sec 6.4.4.5.1, the minimum area of transverse closed stirrups shall be computed by

$$A_v + 2A_t = 0.062 \sqrt{f'_c} \frac{b_w s}{f_{yt}} \quad (6.6.64)$$

But, shall not be less than $(0.35 b_w s) / f_{yt}$.

6.4.4.5.3 Where torsional reinforcement is required by Sec 6.4.4.5.1, the minimum total area of longitudinal torsional reinforcement, $A_{l,min}$, shall be computed by

$$A_{l,min} = \frac{0.42 \sqrt{f'_c} A_{cp}}{f_y} - \left(\frac{A_t}{s}\right) p_h \left(\frac{f_{yt}}{f_y}\right) \quad (6.6.65)$$

Where, A_t/s shall not be taken less than $0.175 b_w / f_{yt}$; f_{yt} refers to closed transverse torsional reinforcement, and f_y refers to longitudinal reinforcement.

6.4.4.6 Spacing of torsion reinforcement

6.4.4.6.1 The spacing of transverse torsion reinforcement shall not exceed the smaller of $P_h / 8$ or 300 mm.

6.4.4.6.2 The longitudinal reinforcement required for torsion shall be distributed around the perimeter of the closed stirrups with a maximum spacing of 300 mm. The longitudinal bars shall be inside the stirrups. There shall be at least one longitudinal bar in each corner of the stirrups. Longitudinal bars shall have a diameter at least 0.042 times the stirrup spacing, but not less than 10 mm diameter.

6.4.4.6.3 Torsional reinforcement shall be provided for a distance of at least $(b_t + d)$ beyond the point required by analysis.

6.4.5 Shear-Friction

6.4.5.1 Application of provisions of Sec 6.4.5 shall be for cases where it is appropriate to consider shear transfer across a given plane, such as: an existing or potential crack, an interface between dissimilar materials, or an interface between two concretes cast at different times.

6.4.5.2 Design of cross sections subject to shear transfer as described in Sec 6.4.5.1 shall be based on Eq. 6.6.47, where V_n is calculated in accordance with provisions of Sec 6.4.5.3 or Sec 6.4.5.4.

6.4.5.3 A crack shall be assumed to occur along the shear plane considered. The required area of shear-friction reinforcement A_{vf} across the shear plane shall be designed using either Sec 6.4.5.4 or any other shear transfer design methods that result in prediction of strength in substantial agreement with results of comprehensive tests.

6.4.5.3.1 Provisions of Sections 6.4.5.5 to 6.4.5.10 shall apply for all calculations of shear transfer strength.

6.4.5.4 Design method for shear-friction

6.4.5.4.1 Where shear-friction reinforcement is perpendicular to the shear plane, V_n shall be computed by

$$V_n = A_{vf} f_y \mu \quad (6.6.66)$$

Where, μ is coefficient of friction in accordance with Sec 6.4.5.4.3.

6.4.5.4.2 Where shear-friction reinforcement is inclined to the shear plane, such that the shear force produces tension in shear-friction reinforcement Figure 6.6.11, V_n shall be computed by

$$V_n = A_{vf} f_y (\mu \sin \alpha + \cos \alpha) \quad (6.6.67)$$

Where, α is angle between shear-friction reinforcement and shear plane.

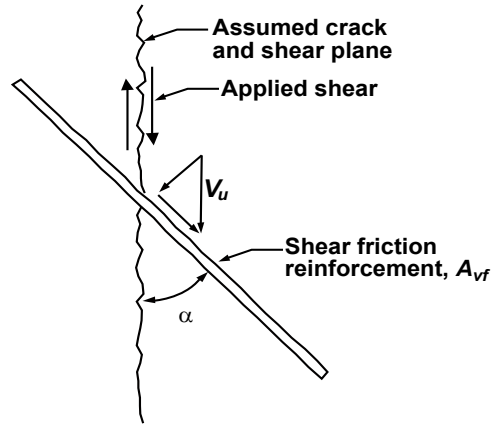


Figure 6.6.11 Shear-friction reinforcement at an angle to assumed crack

6.4.5.4.3 The coefficient of friction μ in Eq. 6.6.66 and Eq. 6.6.67 shall be taken as:

- | | |
|--|---------------|
| (a) Concrete placed monolithically | 1.4 λ |
| (b) Concrete placed against hardened concrete with surface intentionally roughened as specified in Sec 6.4.5.9 | 1.0 λ |
| (c) Concrete placed against hardened concrete not intentionally roughened | 0.6 λ |
| (d) Concrete anchored to as-rolled structural steel by headed studs or by reinforcing bars (see 6.4.5.10) | 0.7 λ |

Where, $\lambda = 1.0$ for normal weight concrete and 0.75 for all light weight concrete. Otherwise, λ shall be determined based on volumetric proportions of light weight and normal weight aggregates as specified in Sec 6.1.8.1, but shall not exceed 0.85.

6.4.5.5 For normal weight concrete either placed monolithically or placed against hardened concrete with surface intentionally roughened as specified in Sec 6.4.5.9, V_n shall not exceed the smallest of $0.2f'_cA_c$, $(3.3 + 0.08f'_c)A_c$ and $11A_c$, where A_c is area of concrete section resisting shear transfer. For all other cases, V_n shall not exceed the smaller of $0.2f'_cA_c$ or $5.5A_c$. Where concretes of different strengths are cast against each other, the value of f'_c used to evaluate V_n shall be that of the lower-strength concrete.

6.4.5.6 The value of f_y used for design of shear-friction reinforcement shall not exceed 420 MPa.

6.4.5.7 Net tension across shear plane shall be resisted by additional reinforcement. Permanent net compression across shear plane shall be permitted to be taken as additive to $A_{vf}f_y$, the force in the shear-friction reinforcement, when calculating required A_{vf} .

6.4.5.8 Shear-friction reinforcement shall be appropriately placed along the shear plane and shall be anchored to develop f_y on both sides by embedment, hooks, or welding to special devices.

6.4.5.9 For the purpose of Sec 6.4.5, when concrete is placed against previously hardened concrete, the interface for shear transfer shall be clean and free of laitance. If μ is assumed equal to 1.0λ , interface shall be roughened to a full amplitude of approximately 6 mm.

6.4.5.10 When shear is transferred between as-rolled steel and concrete using headed studs or welded reinforcing bars, steel shall be clean and free of paint.

6.4.6 Deep Beams

6.4.6.1 The provisions of Sec 6.4.6 shall apply to members with l_n not exceeding four times the overall member depth or regions of beams with concentrated loads within twice the member depth from the support that are loaded on one face and supported on the opposite face so that compression struts can develop between the loads and supports. See also Sec 8.2.7.6 Chapter 8.

6.4.6.2 Deep beams shall be designed using provisions of either nonlinear analysis as permitted in Sec 6.3.7.1, or Appendix I.

6.4.6.3 V_n for deep beams shall not exceed $0.83\sqrt{f_c'}b_wd$.

6.4.6.4 The area of shear reinforcement perpendicular to the flexural tension reinforcement, A_v , shall not be less than $0.0025b_ws$, and s shall not exceed the smaller of $\frac{d}{5}$ and 300 mm.

6.4.6.5 The area of shear reinforcement parallel to the flexural tension reinforcement, A_{vh} , shall not be less than $0.0015b_ws_2$, and s_2 shall not exceed the smaller of $\frac{d}{5}$ and 300 mm.

6.4.6.6 It shall be permitted to provide reinforcement satisfying Sec I.3.3 Appendix I instead of the minimum horizontal and vertical reinforcement specified in Sections 6.4.6.4 and 6.4.6.5.

6.4.7 Provisions for Brackets and Corbels

6.4.7.1 Brackets and corbels, Figures 6.6.12 and 6.6.13, with a shear span-to-depth ratio $\frac{a_v}{d}$ less than 2 shall be permitted to be designed using Appendix I. Design shall be permitted using Sections 6.4.7.3 and 6.4.7.4 for brackets and corbels with:

- (a) $\frac{a_v}{d}$ not greater than 1, and
- (b) Subject to factored horizontal tensile force, N_{uc} , not larger than V_u .

The requirements of Sections 6.4.7.2, 6.4.7.5, 6.4.7.6, and 6.4.7.7 shall apply to design of brackets and corbels. Effective depth d shall be determined at the face of the support.

6.4.7.2 Depth at outside edge of bearing area shall not be less than $0.5d$.

6.4.7.3 Section at face of support shall be designed to resist simultaneously V_u , a factored moment $[V_u a_v + N_{uc}(h - d)]$, and a factored horizontal tensile force N_{uc} .

6.4.7.3.1 In all design calculations in accordance with Sec 6.4.7, ϕ shall be taken equal to 0.75.

6.4.7.3.2 Design of shear-friction reinforcement, A_{vf} to resist V_u shall be in accordance with Sec 6.4.5.

- (a) For normal weight concrete, V_n shall not exceed the smallest of (i) $0.2f'_c b_w d$, (ii) $(3.3 + 0.08f'_c)b_w d$, and (iii) $11b_w d$.
- (b) For all-lightweight or sand-lightweight concrete, V_n shall not be taken greater than the smaller of $(0.2 - \frac{0.07a_v}{d})f'_c b_w d$ and $(5.5 - \frac{1.9a_v}{d})b_w d$.

6.4.7.3.3 Reinforcement A_f to resist factored moment $[V_u a_v + N_{uc}(h - d)]$ shall be computed in accordance with Sections 6.3.2 and 6.3.3.

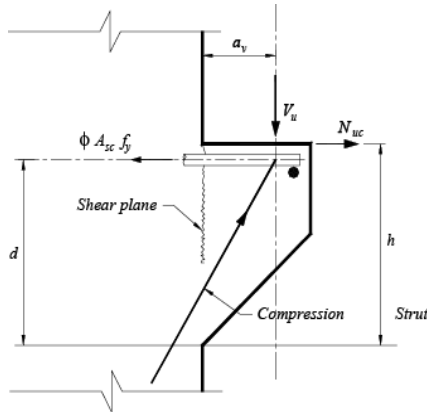


Figure 6.6.12 Structural action of a corbel

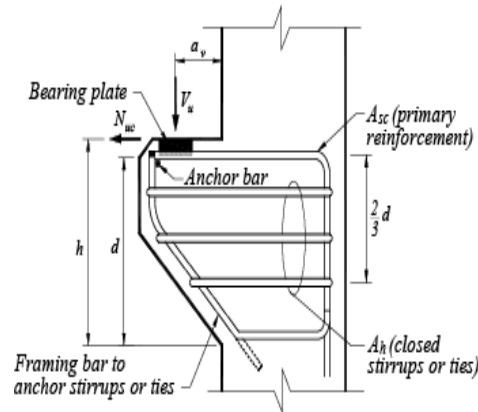


Figure 6.6.13 Notation used in Section 6.4.7

6.4.7.3.4 Reinforcement A_n to resist factored tensile force N_{uc} shall be determined from $\phi A_n f_y \geq N_{uc}$. Factored tensile force, N_{uc} , shall not be taken less than $0.2V_u$ unless provisions are made to avoid tensile forces. N_{uc} shall be regarded as live load even if tension results from restraint of creep, shrinkage, or temperature change.

6.4.7.3.5 Area of primary tension reinforcement A_{sc} shall not be less than the larger of $(A_f + A_n)$ and $\left(\frac{2A_{vf}}{3} + A_n\right)$.

6.4.7.4 Total area, A_h , of closed stirrups or ties parallel to primary tension reinforcement shall not be less than $0.5(A_{sc} - A_n)$. Distribute A_h uniformly within $\left(\frac{2}{3}\right)d$ adjacent to primary tension reinforcement.

6.4.7.5 $\frac{A_{sc}}{bd}$ shall not be less than $0.04\left(\frac{f'_c}{f_y}\right)$.

6.4.7.6 At front face of bracket or corbel, primary tension reinforcement shall be anchored by one of the following:

- (a) By a structural weld to a transverse bar of at least equal size; weld to be designed to develop f_y of primary tension reinforcement;
- (b) By bending primary tension reinforcement back to form a horizontal loop; or
- (c) By some other means of positive anchorage.

6.4.7.7 Bearing area on bracket or corbel neither shall project beyond straight portion of primary tension reinforcement, nor shall project beyond interior face of transverse anchor bar (if one is provided).

6.4.8 Provisions for Walls

6.4.8.1 Design of walls for shear forces perpendicular to face of wall shall be in accordance with provisions for slabs in Sec 6.4.10. Design for horizontal in-plane shear forces in a wall shall be in accordance with Sections 6.4.8.2 to 6.4.8.9. Alternatively, it shall be permitted to design walls with a height not exceeding two times the length of the wall for horizontal shear forces in accordance with Appendix I and Sections 6.4.8.9.2 to 6.4.8.9.5.

6.4.8.2 Design of horizontal section for shear in plane of wall shall be based on Equations 6.6.47 and 6.6.48, where V_c shall be in accordance with Sec 6.4.8.5 or Sec 6.4.8.6 and V_s shall be in accordance with Sec 6.4.8.9.

6.4.8.3 V_n at any horizontal section for shear in plane of wall shall not be taken greater than $0.83\sqrt{f'_c}hd$, where h is thickness of wall, and d is defined in Sec 6.4.8.4.

6.4.8.4 For design for horizontal shear forces in plane of wall, d shall be taken equal to $0.8l_w$. A larger value of d , equal to the distance from extreme compression fiber to center of force of all reinforcement in tension, shall be permitted to be used when determined by a strain compatibility analysis.

6.4.8.5 If a more detailed calculation is not made in accordance with Sec 6.4.8.6, V_c shall not be taken greater than $0.17\lambda\sqrt{f'_c}hd$ for walls subject to axial compression, or V_c shall not be taken greater than the value given in 6.4.2.2.3 for walls subject to axial tension.

6.4.8.6 V_c shall be permitted to be the lesser of the values computed from Equations 6.6.68 and 6.6.69

$$V_c = 0.27\lambda\sqrt{f'_c}hd + \frac{N_u d}{4l_w} \quad (6.6.68)$$

Or,

$$V_c = \left[0.05\lambda\sqrt{f'_c} + \frac{l_w \left(0.1\lambda\sqrt{f'_c} + 0.2\frac{N_u}{l_w h} \right)}{\frac{M_u}{V_u} - \frac{l_w}{2}} \right] hd \quad (6.6.69)$$

Where, l_w is the overall length of the wall, and N_u is positive for compression and negative for tension. If $\left(\frac{M_u}{V_u} - \frac{l_w}{2}\right)$ is negative, Eq. 6.6.69 shall not apply.

6.4.8.7 Sections located closer to wall base than a distance $\frac{l_w}{2}$ or one-half the wall height, whichever is less, shall be permitted to be designed for the same V_c as that computed at a distance $\frac{l_w}{2}$ or one-half the height.

6.4.8.8 Where V_u is less than $0.5\phi V_c$, reinforcement shall be provided in accordance with Sec 6.4.8.9 or in accordance with Sec. 6.6. Where V_u exceeds $0.5\phi V_c$, wall reinforcement for resisting shear shall be provided in accordance with Sec 6.4.8.9.

6.4.8.9 Design of shear reinforcement for walls

6.4.8.9.1 Where V_u exceeds ϕV_c , horizontal shear reinforcement shall be provided to satisfy Equations 6.6.47 and 6.6.48, where V_s shall be computed by

$$V_s = \frac{A_v f_y d}{s} \quad (6.6.70)$$

Where, A_v is area of horizontal shear reinforcement within spacing s , and d is determined in accordance with Sec 6.4.8.4. Vertical shear reinforcement shall be provided in accordance with Sec 6.4.8.9.4.

6.4.8.9.2 Ratio of horizontal shear reinforcement area to gross concrete area of vertical section, ρ_t shall not be less than 0.0025.

6.4.8.9.3 Spacing of horizontal shear reinforcement shall not exceed the smallest of $\frac{l_w}{5}$, $3h$, and 450 mm, where l_w is the overall length of the wall.

6.4.8.9.4 Ratio of vertical shear reinforcement area to gross concrete area of horizontal section, ρ_t shall not be less than the larger of 0.0025 and the value obtained from:

$$\rho_t = 0.0025 + 0.5 \left(2.5 - \frac{h_w}{l_w} \right) (\rho_t - 0.0025) \quad (6.6.71)$$

The value of ρ_t calculated by Eq. 6.6.71 need not be greater than ρ_t required by Sec 6.4.8.9.1. In Eq. 6.6.71, l_w is the overall length of the wall, and h_w is the overall height of the wall.

6.4.8.9.5 Spacing of vertical shear reinforcement shall not exceed the smallest of $\frac{l_w}{3}$, $3h$, and 450 mm, where l_w is the overall length of the wall.

6.4.9 Transfer of Moments to Columns

6.4.9.1 When gravity load, wind, earthquake, or other lateral forces cause transfer of moment at connections of framing elements to columns, the shear resulting from moment transfer shall be considered in the design of lateral reinforcement in the columns.

6.4.9.2 Except for connections not part of a primary seismic load-resisting system that are restrained on four sides by beams or slabs of approximately equal depth, connections shall have lateral reinforcement not less than that required by Eq. 6.6.55 within the column for a depth not less than that of the deepest connection of framing elements to the columns. See also Sec. 8.1.13 Chapter 8.

6.4.10 Provisions for Footings and Slabs

6.4.10.1 The shear strength of footings and slabs in the vicinity of columns, concentrated loads, or reactions is governed by the more severe of the following two conditions:

6.4.10.1.1 Beam action where each critical section to be investigated extends in a plane across the entire width. The slab or footing shall be designed in accordance with Sections 6.4.1 to 6.4.3 for beam action.

6.4.10.1.2 For two-way action, each of the critical sections to be investigated shall be located so that its perimeter b_o is a minimum but need not approach closer than $\frac{d}{2}$ to:

- (a) Edges or corners of columns, concentrated loads, or reaction areas; and
- (b) Changes in slab thickness such as edges of capitals, drop panels, or shear caps.

For two-way action, the slab or footing shall be designed in accordance with Sections 6.4.10.2 to 6.4.10.6.

6.4.10.1.3 For square or rectangular columns, concentrated loads, or reaction areas, the critical sections with four straight sides shall be permitted.

6.4.10.2 For two-way action, the design of a slab or footing is based on Equations 6.6.47 and 6.6.48. V_c shall be computed in accordance with Sec 6.4.10.2.1, or Sec 6.4.10.3.1. V_s shall be computed in accordance with 6.4.10.3. For slabs with shearheads, V_n shall be in accordance with Sec 6.4.10.4. Where moment is transferred between a slab and a column, Sec 6.4.10.6 shall apply.

6.4.10.2.1 For slabs and footings, V_c shall be the smallest of the values given by Equations 6.6.72, 6.6.73 and 6.6.74:

$$V_c = 0.17(1 + \frac{2}{\beta})\lambda\sqrt{f'_c} b_o d \quad (6.6.72)$$

Where, β is the ratio of long side to short side of the column, concentrated load or reaction area;

$$V_c = 0.083(\frac{\alpha_s d}{b_o} + 2)\lambda\sqrt{f'_c} b_o d \quad (6.6.73)$$

Where, α_s is 40 for interior columns, 30 for edge columns, 20 for corner columns; and

$$V_c = 0.33\lambda\sqrt{f'_c} b_o d \quad (6.6.74)$$

6.4.10.3 Bars or wires and single- or multiple-leg stirrups as shear reinforcement shall be permitted in slabs and footings with d greater than or equal to 150 mm, but not less than 16 times the shear reinforcement bar diameter. Shear reinforcement shall be in accordance with Sections 6.4.10.3.1 to 6.4.10.3.4.

6.4.10.3.1 For computing V_n , Eq. 6.6.48 shall be used and V_c shall not be taken greater than $0.17\lambda\sqrt{f'_c b d}$ and V_s shall be calculated in accordance with Sec 6.4.3. In Eq. 6.6.56, A_v shall be taken as the cross-sectional area of all legs of reinforcement on one peripheral line that is geometrically similar to the perimeter of column section.

6.4.10.3.2 V_n shall not be taken greater than $0.5\sqrt{f'_c b d}$

6.4.10.3.3 The distance from the column face to the first line of stirrup legs that surround the column shall not exceed $\frac{d}{2}$. The spacing between adjacent stirrups legs in the first line of shear reinforcement shall not exceed $2d$ measured in a direction parallel to the column face. The spacing between successive lines of shear reinforcement that surround the column shall not exceed $\frac{d}{2}$ measured in a direction perpendicular to the column face. In a slab-column connection for which the moment transfer is negligible, the shear reinforcement should be symmetrical about the centroid of the critical section Figure 6.6.14. Spacing limits defined above are also shown in Figure 6.6.14 for interior column and in Figure 6.6.15 for edge column. At edge columns or for interior connections where moment transfer is significant, closed stirrups are recommended in a pattern as symmetrical as possible.

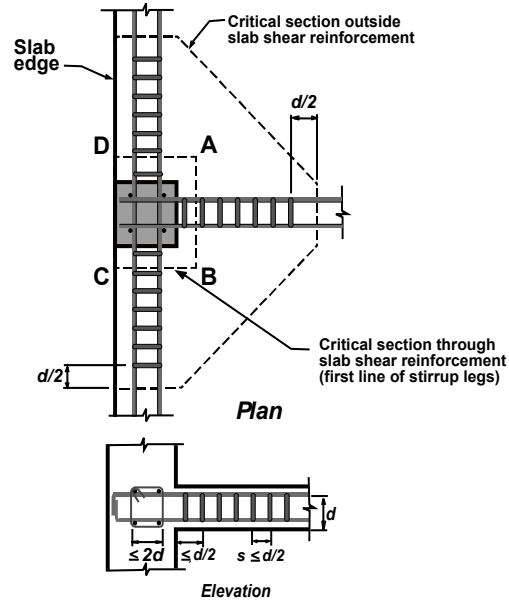
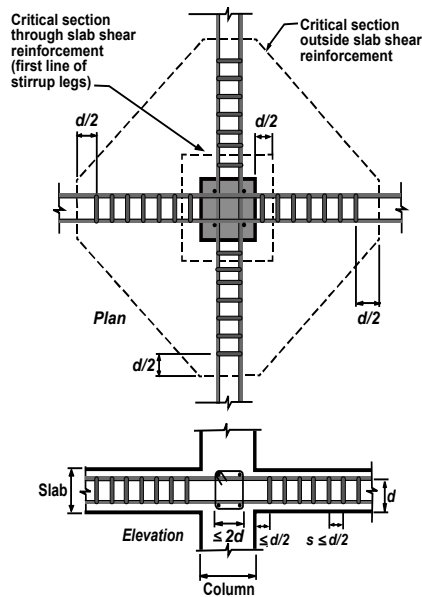


Figure 6.6.14 Arrangement of stirrup shear reinforcement around interior column **Figure 6.6.15 Arrangement of stirrup shear reinforcement around edge column**

6.4.10.3.4 Slab shear reinforcement shall satisfy the anchorage requirements of Sec 8.2.10 Chapter 8 and shall engage the longitudinal flexural reinforcement in the direction being considered.

6.4.10.4 Shear reinforcement consisting of structural steel I- or channel-shaped sections (shearheads) shall be permitted in slabs. The provisions of Sections 6.4.10.4.1 to 6.4.10.4.9 shall apply where shear due to gravity load is transferred at interior column supports. Where moment is transferred to columns, Sec 6.4.10.7.3 shall apply.

6.4.10.4.1 Each shearhead shall consist of steel shapes fabricated by welding with a full penetration weld into identical arms at right angles. Shearhead arms shall not be interrupted within the column section.

6.4.10.4.2 A shearhead shall not be deeper than 70 times the web thickness of the steel shape.

6.4.10.4.3 The ends of each shearhead arm shall be permitted to be cut at angles not less than 30 degrees with the horizontal, provided the plastic moment strength of the remaining tapered section is adequate to resist the shear force attributed to that arm of the shearhead.

6.4.10.4.4 All compression flanges of steel shapes shall be located within $0.3d$ of compression surface of slab.

6.4.10.4.5 The ratio α_v between the flexural stiffness of each shearhead arm and that of the surrounding composite cracked slab section of width $(c_2 + d)$ shall not be less than 0.15.

6.4.10.4.6 Plastic moment strength, M_p , required for each arm of the shearhead shall be computed by

$$M_p = \frac{V_u}{2\phi n} \left[h_v + \alpha_v \left(l_v - \frac{c_1}{2} \right) \right] \quad (6.6.75)$$

Where, ϕ is for tension-controlled members, n is number of shearhead arms, and l_v is minimum length of each shearhead arm required to comply with requirements of Sections 6.4.10.4.7 and 6.4.10.4.8.

6.4.10.4.7 The critical slab section for shear shall be perpendicular to the plane of the slab and shall cross each shearhead arm at three-quarters the distance $\left[l_v - \left(\frac{c_1}{2} \right) \right]$ from the column face to the end of the shearhead arm. The critical section shall be located so that its perimeter b_o is a minimum, but need not be closer than the perimeter defined in Sec 6.4.10.1.2(a).

6.4.10.4.8 V_n shall not be taken larger than $0.33\sqrt{f'_c b_o d}$ on the critical section defined in Sec 6.4.10.4.7. When shearhead reinforcement is provided, V_n shall not be taken greater than $0.58\sqrt{f'_c b_o d}$ on the critical section defined in Sec 6.4.10.1.2(a).

6.4.10.4.9 Moment resistance M_v contributed to each slab column strip by a shearhead shall not be taken greater than

$$M_v = \frac{\phi \alpha_v V_u}{2n} \left(l_v - \frac{c_1}{2} \right) \quad (6.6.76)$$

Where, ϕ is for tension-controlled members, n is number of shearhead arms, and l_v is length of each shearhead arm actually provided. However, M_v shall not be taken larger than the smallest of:

- (a) 30 percent of the total factored moment required for each slab column strip;
- (b) The change in column strip moment over the length l_v ;
- (c) M_p computed by Eq. 6.6.75.

6.4.10.4.10 When unbalanced moments are considered, the shearhead must have adequate anchorage to transmit M_p to the column.

6.4.10.5 Headed shear stud reinforcement, placed perpendicular to the plane of a slab or footing, shall be permitted in slabs and footings in accordance with 6.4.10.5.1 through 6.4.10.5.4. The overall height of the shear stud assembly shall not be less than the thickness of the member less the sum of: (1) the concrete cover on the top flexural reinforcement; (2) the concrete cover on the base rail; and (3) one-half the bar diameter of the tension flexural reinforcement. Where flexural tension reinforcement is at the bottom of the section, as in a footing, the overall height of the shear stud assembly shall not be less than the thickness of the member less the sum of: (1) the concrete cover on the bottom flexural reinforcement; (2) the concrete cover on the head of the stud; and (3) one-half the bar diameter of the bottom flexural reinforcement.

6.4.10.5.1 For the critical section defined in Sec 6.4.10.1.2, V_n shall be computed using Eq. 6.6.48, with V_c and V_n not exceeding $0.25\lambda\sqrt{f'_c}b_o d$ and $0.66\lambda\sqrt{f'_c}b_o d$ respectively. V_s shall be calculated using Eq. 6.6.56 with A_v equal to the cross-sectional area of all the shear reinforcement on one peripheral line that is approximately parallel to the perimeter of the column section, where s is the spacing of the peripheral lines of headed shear stud reinforcement. $\frac{A_v f_{yt}}{b_o s}$ shall not be less

than $0.17\sqrt{f'_c}$

6.4.10.5.2 The spacing between the column face and the first peripheral line of shear reinforcement shall not exceed $\frac{d}{2}$. The spacing between peripheral lines of shear reinforcement, measured in a direction perpendicular to any face of the column, shall be constant. For all slabs and footings, the spacing shall be based on the value of the shear stress due to factored shear force and unbalanced moment at the critical section defined in Sec 6.4.10.1.2, and shall not exceed:

- (a) $0.75d$, where maximum shear stresses due to factored loads are less than or equal to $0.5\phi\sqrt{f'_c}$; and
- (b) $0.5d$, where maximum shear stresses due to factored loads are greater than $0.5\phi\sqrt{f'_c}$.

6.4.10.5.3 The spacing between adjacent shear reinforcement elements, measured on the perimeter of the first peripheral line of shear reinforcement, shall not exceed $2d$.

6.4.10.5.4 Shear stress due to factored shear force and moment shall not exceed $0.17\phi\lambda\sqrt{f'_c}$ at the critical section located $\frac{d}{2}$ outside the outermost peripheral line of shear reinforcement.

6.4.10.6 Openings in slabs

If openings in slabs are located at a distance less than 10 times the slab thickness from a concentrated load or reaction area, or when openings in flat slabs are located within column strips as defined in Sec. 6.5, the critical slab sections for shear defined in Sections 6.4.10.1.2 and 6.4.10.4.7 shall be modified as follows:

6.4.10.6.1 For slabs without shearheads, that part of the perimeter of the critical section that is enclosed by straight lines projecting from the centroid of the column, concentrated load, or reaction area and tangent to the boundaries of the openings shall be considered ineffective Figure 6.6.16.

6.4.10.6.2 For slabs with shearheads, the ineffective portion of the perimeter shall be one-half of that defined in Sec 6.4.10.6.1.

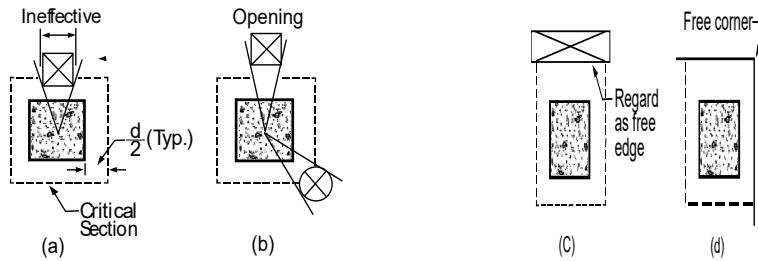


Figure 6.6.16 Effective perimeter (in dashed lines) to consider effect of openings and free edges

6.4.10.7 Transfer of moment in slab-column connections

6.4.10.7.1 Where gravity load, wind, earthquake, or other lateral forces cause transfer of unbalanced moment M_u between a slab and column, $\gamma_f M_u$ shall be transferred by flexure in accordance with Sec 6.5.5.3. The remainder of the unbalanced moment, $\gamma_v M_u$, shall be considered to be transferred by eccentricity of shear about the centroid of the critical section defined in Sec 6.4.10.1.2 where

$$\gamma_v = (1 - \gamma_f) \quad (6.6.77)$$

6.4.10.7.2 The shear stress resulting from moment transfer by eccentricity of shear shall be assumed to vary linearly about the centroid of the critical sections defined in Sec 6.4.10.1.2. The maximum shear stress due to V_u and M_u shall not exceed ϕv_n :

- (a) For members without shear reinforcement,

$$\phi V_n = \phi V_c / (b_o d) \quad (6.6.78)$$

Where, V_c is as defined in Sec 6.4.10.2.1.

- (b) For members with shear reinforcement other than shearheads,

$$\phi V_n = \phi (V_c + V_s) / (b_o d) \quad (6.6.79)$$

Where, V_c and V_s are defined in Sec 6.4.10.3.1. The design shall take into account the variation of shear stress around the column. The shear stress due to factored shear force and moment shall not exceed $(0.17\phi\lambda\sqrt{f'_c})$ at the critical section located $\frac{d}{2}$ outside the outermost line of stirrup legs that surround the column.

The maximum factored shear stress may be obtained from the combined shear stresses on the left and right faces of the column (Figure 6.6.17) as given by the following Equations:

$$v_l = \frac{V_u}{A_c} - \frac{\gamma_v M_u c_l}{J_c} \quad (6.6.80a)$$

$$v_r = \frac{V_u}{A_c} + \frac{\gamma_v M_u c_r}{J_c} \quad (6.6.80b)$$

Where, A_c = area of concrete of assumed critical section = $2d(c_1 + c_2 + 2d)$

c_l, c_r = distances from centroid of critical section to left and right face of section respectively

c_1, c_2 = width and depth of the column

J_c = property of assumed critical section analogous to polar moment of inertia. For an interior column, the quantity J_c is

$$J_c = \frac{2d(c_1+d)^3}{12} + \frac{2(c_1+d)d^3}{12} + 2d(c_2+d) \left(\frac{c_1+d}{2}\right)^2 \quad (6.6.80c)$$

6.4.10.7.3 When shear reinforcement consisting of structural steel I- or channel-shaped sections (shearheads) is provided, the sum of the shear stresses due to vertical load acting on the critical section defined by Sec 6.4.10.4.7 and the shear stresses resulting from moment transferred by eccentricity of shear about the centroid of the critical section defined in Sec 6.4.10.1.2(a) and 6.4.10.1.3 shall not exceed . $0.33\phi\lambda\sqrt{f'_c}$.

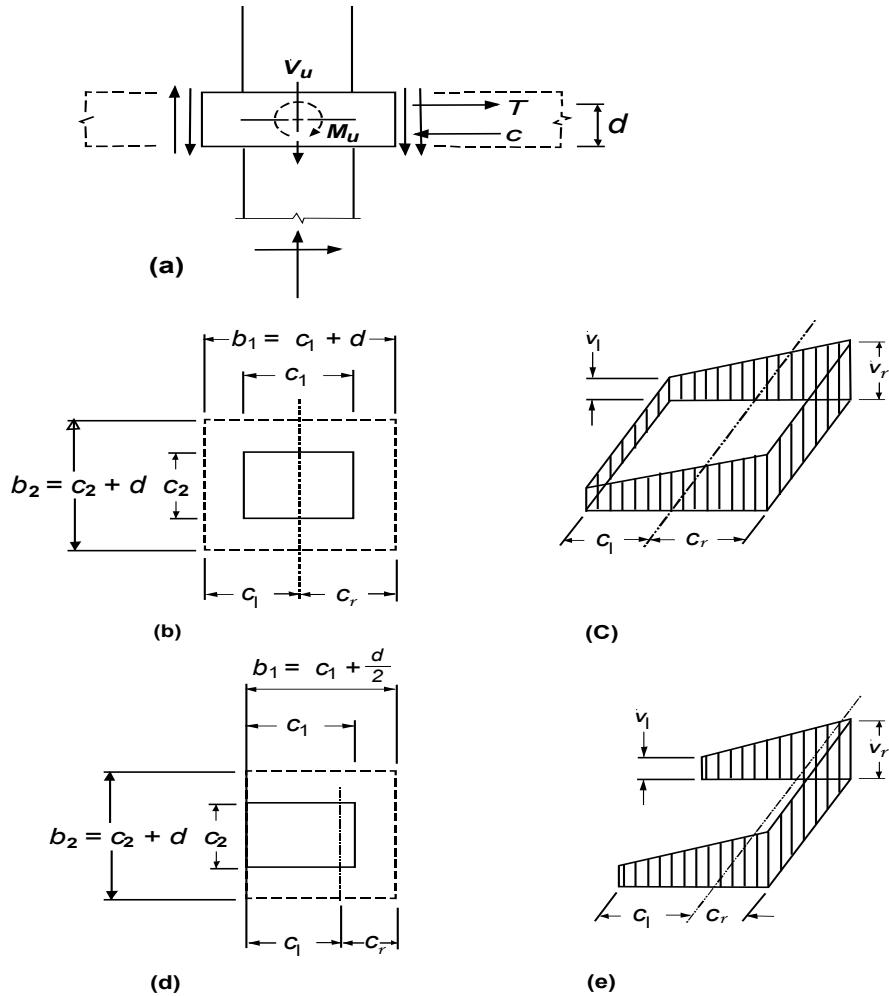


Figure 6.6.17 Transfer of moment from slab to column: (a) forces resulting from vertical load and unbalanced moment; (b) critical section for an interior column; (c) shear stress distribution for an interior column; (d) critical section for an edge column; (e) shear stress distribution for an edge column

6.5 Two-Way Slab Systems: Flat Plates, Flat Slabs and Edge-Supported Slabs

6.5.1 Scope

The provisions of this section shall apply to all slabs, solid, ribbed or hollow, spanning in more than one direction, with or without beams between the supports. Flat plate is a term normally attributed to slabs without beams and without drop panels, column capitals, or brackets. On the other hand, slabs without beams, but with drop panels, column capital or brackets are commonly known as flat slabs. While this section covers the requirements for all types of slabs, the provisions of Sec 6.5.8. Alternative Design of Two-way Edge-Supported slabs, may be used as an alternative for slabs supported on all four edges by walls, steel beams or monolithic concrete beams having a total depth not less than 3 times the slab thickness.

6.5.1.1 For a slab system supported by columns or walls, dimensions c_1 , c_2 , and l_n shall be based on an effective support area defined by the intersection of the bottom surface of the slab, or of the drop panel or shear cap if present, with the largest right circular cone, right pyramid, or tapered wedge whose surfaces are located within the column and the capital or bracket and are oriented no greater than 45° to the axis of the column.

6.5.1.2 Minimum thickness of slabs designed in accordance with Sec. 6.5 shall be as required by Sec 6.2.5.3.

6.5.2 General

6.5.2.1 Column strip is a design strip with a width on each side of a column centerline equal to $0.25l_2$ or $0.25l_1$, whichever is less. Column strip includes beams, if any.

6.5.2.2 Middle strip is a design strip bounded by two column strips.

6.5.2.3 A panel is bounded by column, beam, or wall centerlines on all sides.

6.5.2.4 For monolithic or fully composite construction, a beam includes that portion of slab on each side of the beam extending a distance equal to the projection of the beam above or below the slab, whichever is greater, but not greater than four times the slab thickness (Figure 6.6.18).

6.5.2.5 When used to reduce the amount of negative moment reinforcement over a column or minimum required slab thickness, a drop panel shall:

- (a) project below the slab at least one-quarter of the adjacent slab thickness; and
- (b) extend in each direction from the centerline of support a distance not less than one-sixth the span length measured from center-to-center of supports in that direction.

When used to increase the critical condition section for shear at a slab-column joint, a shear cap shall project below the slab and extend a minimum horizontal distance from the face of the column that is equal to the thickness of the projection below the slab soffit.

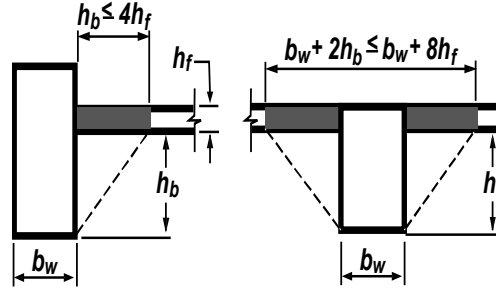


Figure 6.6.18 Portion of slab to be included with the beam

6.5.3 Slab Reinforcement

6.5.3.1 Area of reinforcement in each direction for two-way slab systems shall be determined from moments at critical sections, but shall not be less than required by Sec. 8.1.11.2 Chapter 8.

6.5.3.2 Spacing of reinforcement at critical sections shall not exceed two times the slab thickness, except for portions of slab area of cellular or ribbed construction. In the slab over cellular spaces, reinforcement shall be provided as required by Sec. 8.1.11 Chapter 8.

6.5.3.3 Positive moment reinforcement perpendicular to a discontinuous edge shall extend to the edge of slab and have embedment, straight or hooked, at least 150 mm in spandrel beams, columns, or walls.

6.5.3.4 Negative moment reinforcement perpendicular to a discontinuous edge shall be bent, hooked, or otherwise anchored in spandrel beams, columns, or walls, and shall be developed at face of support according to provisions of Sec. 8.2 Chapter 8.

6.5.3.5 Where a slab is not supported by a spandrel beam or wall at a discontinuous edge, or where a slab cantilevers beyond the support, anchorage of reinforcement shall be permitted within the slab.

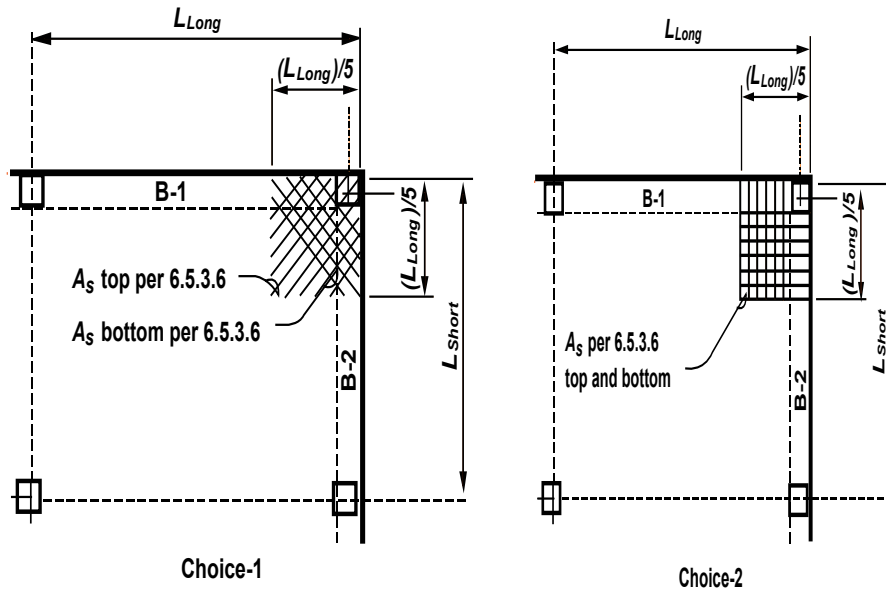
6.5.3.6 At exterior corners of slabs supported by edge walls or where one or more edge beams have a value of α_f greater than 1.0, top and bottom slab reinforcement shall be provided at exterior corners in accordance with Sections 6.5.3.6.1 to 6.5.3.6.4 and as shown in Figure 6.6.19.

6.5.3.6.1 Corner reinforcement in both top and bottom of slab shall be sufficient to resist a moment per unit of width equal to the maximum positive moment per unit width in the slab panel.

6.5.3.6.2 The moment shall be assumed to be about an axis perpendicular to the diagonal from the corner in the top of the slab and about an axis parallel to the diagonal from the corner in the bottom of the slab.

6.5.3.6.3 Corner reinforcement shall be provided for a distance in each direction from the corner equal to one-fifth the longer span.

6.5.3.6.4 Corner reinforcement shall be placed parallel to the diagonal in the top of the slab and perpendicular to the diagonal in the bottom of the slab. Alternatively, reinforcement shall be placed in two layers parallel to the sides of the slab in both the top and bottom of the slab.



Notes:

1. Applies if B-1 or B-2 has $\alpha_f > 1.0$
2. Maximum bar spacing $2h$, where h = slab thickness
3. Reinforcement same as maximum +ve reinforcement of the panel

Figure 6.6.19 Corner reinforcement in slabs

6.5.3.7 When a drop panel is used to reduce the amount of negative moment reinforcement over the column of a flat slab, the dimensions of the drop panel shall be in accordance with Sec 6.5.2.5. In computing required slab reinforcement, the thickness of the drop panel below the slab shall not be assumed to be greater than one-quarter the distance from the edge of drop panel to the face of column or column capital.

6.5.3.8 Details of reinforcement in slabs without beams

6.5.3.8.1 In addition to the other requirements of Sec 6.5.3, reinforcement in slabs without beams shall have minimum extensions as prescribed in Figure 6.6.20.

6.5.3.8.2 Where adjacent spans are unequal, extensions of negative moment reinforcement beyond the face of support as prescribed in Figure 6.6.20 shall be based on requirements of the longer span.

6.5.3.8.3 Bent bars shall be permitted only when depth-span ratio permits use of bends of 45 degrees or less.

6.5.3.8.4 In frames where two-way slabs act as primary members resisting lateral loads, lengths of reinforcement shall be determined by analysis but shall not be less than those prescribed in Figure 6.6.20.

6.5.3.8.5 All bottom bars or wires within the column strip, in each direction, shall be continuous or spliced with Class B tension splices or with mechanical or welded splices satisfying Sec. 8.2.12.3 Chapter 8. Splices shall be located as shown in Figure 6.6.20. At least two of the column strip bottom bars or wires in each direction shall pass within the region bounded by the longitudinal reinforcement of the column and shall be anchored at exterior supports.

6.5.3.8.6 In slabs with shearheads and in lift-slab construction where it is not practical to pass the bottom bars required by 6.5.3.8.5 through the column, at least two bonded bottom bars or wires in each direction shall pass through the shearhead or lifting collar as close to the column as practicable and be continuous or spliced with a Class A splice. At exterior columns, the reinforcement shall be anchored at the shearhead or lifting collar.

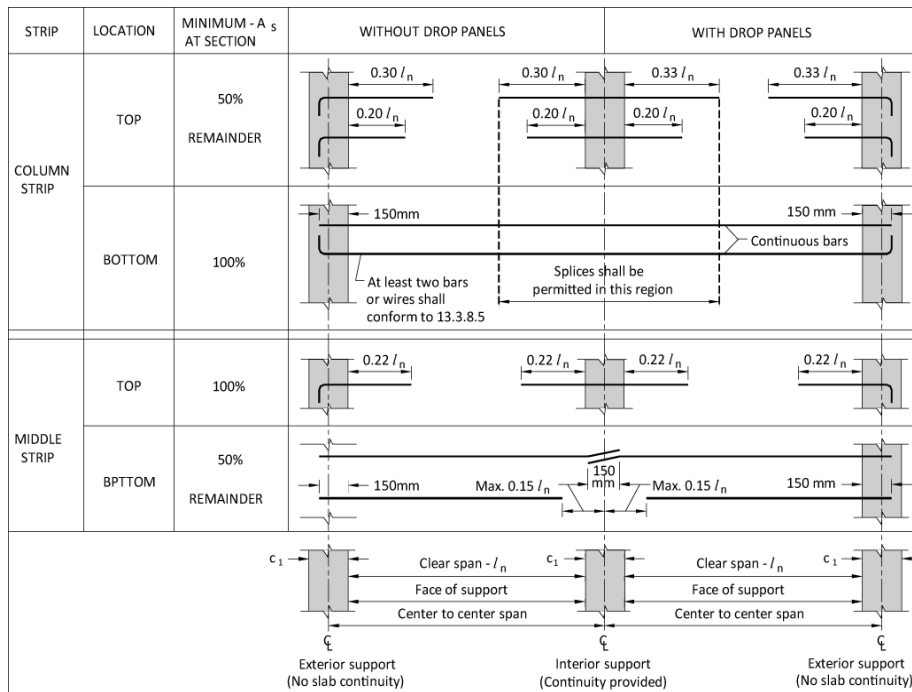


Figure 6.6.20 Minimum extensions for reinforcement in slabs without beams for reinforcement extension into supports

6.5.4 Openings in Slab Systems

6.5.4.1 Openings of any size shall be permitted in slab systems if shown by analysis that the design strength is at least equal to the required strength set forth in Sections 6.2.2 and 6.2.3, and that all serviceability conditions, including the limits on deflections, are met.

6.5.4.2 As an alternate to analysis required by Sec 6.5.4.1, openings shall be permitted in slab systems without beams only, in accordance with Sections 6.5.4.2.1 to 6.5.4.2.4.

6.5.4.2.1 Openings of any size shall be permitted in the area common to intersecting middle strips, provided total amount of reinforcement required for the panel without the opening is maintained.

6.5.4.2.2 In the area common to intersecting column strips, not more than one-eighth the width of column strip in either span shall be interrupted by openings. An amount of reinforcement equivalent to that interrupted by an opening shall be added on the sides of the opening.

6.5.4.2.3 In the area common to one column strip and one middle strip, not more than one-quarter of the reinforcement in either strip shall be interrupted by openings. An amount of reinforcement equivalent to that interrupted by an opening shall be added on the sides of the opening.

6.5.4.2.4 Shear requirements of Sec 6.4.10.6 shall be satisfied.

6.5.5 Design Procedures

6.5.5.1 A slab system shall be designed by any procedure satisfying conditions of equilibrium and geometric compatibility, if shown that the design strength at every section is at least equal to the required strength set forth in Sections 6.2.2 and 6.2.3, and that all serviceability conditions, including limits on deflections, are met.

6.5.5.1.1 Design of a slab system for gravity loads, including the slab and beams (if any) between supports and supporting columns or walls forming orthogonal frames, by either the Direct Design Method of Sec 6.5.6 or the Equivalent Frame Method of Sec 6.5.7, shall be permitted.

6.5.5.1.2 For lateral loads, analysis of frames shall take into account effects of cracking and reinforcement on stiffness of frame members.

6.5.5.1.3 Combining the results of the gravity load analysis with the results of the lateral load analysis shall be permitted.

6.5.5.2 The slab and beams (if any) between supports shall be proportioned for factored moments prevailing at every section.

6.5.5.3 When gravity load, wind, earthquake, or other lateral forces cause transfer of moment between slab and column, a fraction of the unbalanced moment shall be transferred by flexure in accordance with Sections 6.5.5.3.2 to 6.5.5.3.4.

6.5.5.3.1 The fraction of unbalanced moment not transferred by flexure shall be transferred by eccentricity of shear in accordance with Sec 6.4.10.7.

6.5.5.3.2 A fraction of the unbalanced moment given by $\gamma_f M_u$ shall be considered to be transferred by flexure within an effective slab width between lines that are one and one-half slab or drop panel thickness ($1.5h$) outside opposite faces of the column or capital, where M_u is the factored moment to be transferred and

$$\gamma_f = \frac{1}{1+(2/3)\sqrt{b_1/b_2}} \quad (6.6.81)$$

6.5.5.3.3 For slabs with unbalanced moments transferred between the slab and columns, it shall be permitted to increase the value of γ_f given by Eq. 6.6.81 in accordance with the following:

- (a) For edge columns with unbalanced moments about an axis parallel to the edge, $\gamma_f = 1.0$ provided that V_u at an edge support does not exceed $0.75\phi V_c$, or at a corner support does not exceed $0.5\phi V_c$.
- (b) For unbalanced moments at interior supports, and for edge columns with unbalanced moments about an axis perpendicular to the edge, increase γ_f to as much as 1.25 times the value from Eq. 6.6.81, but not more than $\gamma_f = 1.0$, provided that V_u at the support does not exceed $0.4\phi V_c$. The net tensile strain ϵ_t calculated for the effective slab width defined in Sec 6.5.5.3.2 shall not be less than 0.010.

The value of V_c in items (a) and (b) shall be calculated in accordance with Sec 6.4.10.2.1.

6.5.5.3.4 Concentration of reinforcement over the column by closer spacing or additional reinforcement shall be used to resist moment on the effective slab width defined in Sec 6.5.5.3.2.

6.5.5.4 Design for transfer of load from slabs to supporting columns or walls through shear and torsion shall be in accordance with Sec. 6.4.

6.5.6 Direct Design Method

6.5.6.1 Limitations

Design of slab systems within the limitations of Sections 6.5.6.1.1 to 6.5.6.1.8 by the direct design method shall be permitted.

- 6.5.6.1.1 There shall be a minimum of three continuous spans in each direction.
- 6.5.6.1.2 Panels shall be rectangular, with a ratio of longer to shorter span center-to-center of supports within a panel not greater than 2.
- 6.5.6.1.3 Successive span lengths center-to-center of supports in each direction shall not differ by more than one-third the longer span.
- 6.5.6.1.4 Offset of columns by a maximum of 10 percent of the span (in direction of offset) from either axis between centerlines of successive columns shall be permitted.
- 6.5.6.1.5 All loads shall be due to gravity only and uniformly distributed over an entire panel. The unfactored live load shall not exceed two times the unfactored dead load.
- 6.5.6.1.6 For a panel with beams between supports on all sides, Eq. 6.6.82 shall be satisfied for beams in the two perpendicular directions.

$$0.2 \leq \frac{\alpha_{f1}l_2^2}{\alpha_{f2}l_1^2} \leq 5.0 \quad (6.6.82)$$

Where, α_{f1} and α_{f2} are calculated using respective stiffness parameters in accordance with the general Equation 6.6.83.

$$\alpha_f = \frac{E_{cb}I_b}{E_{cs}I_s} \quad (6.6.83)$$

- 6.5.6.1.7 Moment redistribution as permitted by Sec 6.1.6 shall not be applied for slab systems designed by the direct design method. See Sec 6.5.6.7.
- 6.5.6.1.8 Variations from the limitations of Sec 6.5.6.1 shall be permitted if demonstrated by analysis that requirements of Sec 6.5.5.1 are satisfied.

6.5.6.2 Total factored static moment for a span

- 6.5.6.2.1 Total factored static moment, M_o , for a span shall be determined in a strip bounded laterally by centerline of panel on each side of centerline of supports.
- 6.5.6.2.2 Absolute sum of positive and average negative factored moments in each direction shall not be less than

$$M_o = \frac{q_u l_2 l_n^2}{8} \quad (6.6.84)$$

Where, l_n is length of clear span in direction that moments are being determined.

6.5.6.2.3 Where the transverse span of panels on either side of the centerline of supports varies, l_2 in Eq. 6.6.84 shall be taken as the average of adjacent transverse spans.

6.5.6.2.4 When the span adjacent and parallel to an edge is being considered, the distance from edge to panel centerline shall be substituted for l_2 in Eq. 6.6.84.

6.5.6.2.5 Clear span l_n shall extend from face to face of columns, capitals, brackets, or walls. Value of l_n used in Eq. 6.6.84 shall not be less than $0.65l_1$. Circular or regular polygon-shaped supports shall be treated as square supports with the same area.

6.5.6.3 Negative and positive factored moments

6.5.6.3.1 Negative factored moments shall be located at face of rectangular supports. Circular or regular polygon-shaped supports shall be treated as square supports with the same area.

6.5.6.3.2 In an interior span, total static moment, M_o , shall be distributed as follows:

Negative factored moment: 0.65

Positive factored moment: 0.35

6.5.6.3.3 In an end span, total factored static moment, M_o , shall be distributed as in Table 6.6.4 below:

Table 6.6.4: Distribution of Total Factored Static Moment, M_o in an End Span

Moments	Exterior edge unrestrained	Slab with beams between all supports	Slab without beams between interior supports		Exterior edge fully restrained
			Without edge beam	With edge beam	
Interior negative factored moment	0.75	0.70	0.70	0.70	0.65
Positive factored moment	0.63	0.57	0.52	0.50	0.35
Exterior negative factored moment	0	0.16	0.26	0.30	0.65

6.5.6.3.4 Negative moment sections shall be designed to resist the larger of the two interior negative factored moments determined for spans framing into a common support unless an analysis is made to distribute the unbalanced moment in accordance with stiffnesses of adjoining elements.

6.5.6.3.5 Edge beams or edges of slab shall be proportioned to resist in torsion their share of exterior negative factored moments.

6.5.6.3.6 The gravity load moment to be transferred between slab and edge column in accordance with 6.5.5.3.1 shall be $0.3M_o$.

6.5.6.4 Factored moments in column strips

6.5.6.4.1 Column strips shall be proportioned to resist the portions in percent of interior negative factored moments as shown in Table 6.6.5.

6.5.6.4.2 Column strips shall be proportioned to resist the portions in percent of exterior negative factored moments as shown in Table 6.6.6.

Table 6.6.5: Portions of Interior Negative Moments to be resisted by Column Strip

Parameters	l_2 / l_1		
	0.5	1.0	2.0
$\left(\frac{\alpha_{f1}l_2}{l_1}\right) = 0$	75	75	75
$\left(\frac{\alpha_{f1}l_2}{l_1}\right) \geq 1$	90	75	45

Notes: Linear interpolations shall be made between values shown.

Interpolation function for % of Moment = $75 + 30\left(\frac{\alpha_{f1}l_2}{l_1}\right)\left(1 - \frac{l_2}{l_1}\right)$

Table 6.6.6: Portions of Exterior Negative Moments to be resisted by Column Strip

Parameters		l_2 / l_1		
		0.5	1.0	2.0
$\left(\frac{\alpha_{f1}l_2}{l_1}\right) = 0$	$\beta_t = 0$	100	100	100
	$\beta_t \geq 2.5$	75	75	75
$\left(\frac{\alpha_{f1}l_2}{l_1}\right) \geq 1$	$\beta_t = 0$	100	100	100
	$\beta_t \geq 2.5$	90	75	45

Linear interpolations shall be made between values shown, where β_t is calculated in Eq. 6.6.85 and C is calculated in Eq. 6.6.86.

$$\beta_t = \frac{E_{cb}C}{2E_{cs}I_s} \quad (6.6.85)$$

$$C = \sum \left(1 - 0.63 \frac{x}{y}\right) \frac{x^3 y}{3} \quad (6.6.86)$$

The constant C for T or L sections shall be permitted to be evaluated by dividing the section into separate rectangular parts, as defined in Sec 6.5.2.4, and summing the values of C for each part.

$$\text{Interpolation function for \% of Moment} = 100 - 10\beta_t + 12\beta_t \left(\frac{\alpha_{f1}l_2}{l_1} \right) \left(1 - \frac{l_2}{l_1} \right)$$

6.5.6.4.3 Where supports consist of columns or walls extending for a distance equal to or greater than $0.75l_2$ used to compute M_o , negative moments shall be considered to be uniformly distributed across l_2 .

6.5.6.4.4 Column strips shall be proportioned to resist the portions in percent of positive factored moments shown in Table 6.6.7.

6.5.6.4.5 For slabs with beams between supports, the slab portion of column strips shall be proportioned to resist that portion of column strip moments not resisted by beams.

Table 6.6.7: Portions of Positive Moment to be resisted by Column Strip

Parameters	l_2/l_1		
	0.5	1.0	2.0
$\left(\frac{\alpha_{f1}l_2}{l_1} \right) = 0$	60	60	60
$\left(\frac{\alpha_{f1}l_2}{l_1} \right) \geq 1$	90	75	45

Notes: Linear interpolations shall be made between values shown.

$$\text{Interpolation function for \% of Moment} = 60 + 30 \left(\frac{\alpha_{f1}l_2}{l_1} \right) \left(1.5 - \frac{l_2}{l_1} \right)$$

6.5.6.5 Factored moments in beams

6.5.6.5.1 Beams between supports shall be proportioned to resist 85 percent of column strip moments if $\alpha_{f1}l_2/l_1$ is equal to or greater than 1.0.

6.5.6.5.2 For values of $\alpha_{f1}l_2/l_1$ between 1.0 and zero, proportion of column strip moments resisted by beams shall be obtained by linear interpolation between 85 and zero percent.

6.5.6.5.3 In addition to moments calculated for uniform loads according to Sections 6.5.6.2.2, 6.5.6.5.1, and 6.5.6.5.2, beams shall be proportioned to resist all moments caused by concentrated or linear loads applied directly to beams, including weight of projecting beam stem above or below the slab.

6.5.6.6 Factored moments in middle strips

6.5.6.6.1 That portion of negative and positive factored moments not resisted by column strips shall be proportionately assigned to corresponding half middle strips.

6.5.6.6.2 Each middle strip shall be proportioned to resist the sum of the moments assigned to its two half middle strips.

6.5.6.6.3 A middle strip adjacent to and parallel with a wall-supported edge shall be proportioned to resist twice the moment assigned to the half middle strip corresponding to the first row of interior supports.

6.5.6.7 Modification of factored moments

Modification of negative and positive factored moments by 10 percent shall be permitted provided the total static moment for a panel, M_o , in the direction considered is not less than that required by Eq. 6.6.84.

6.5.6.8 Factored shear in slab systems with beams

6.5.6.8.1 Beams with $\alpha_{f1}l_2/l_1$ equal to or greater than 1.0 shall be proportioned to resist shear caused by factored loads on tributary areas which are bounded by 45° lines drawn from the corners of the panels and the centerlines of the adjacent panels parallel to the long sides (Figure 6.6.21).

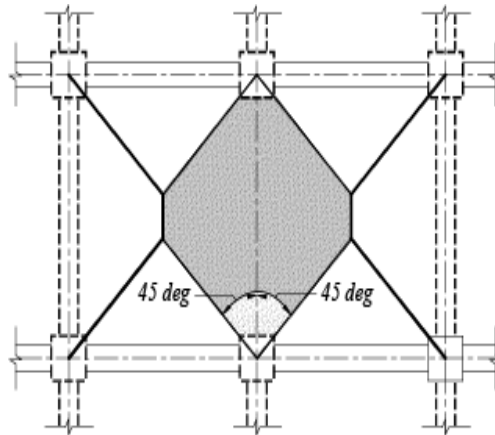


Figure 6.6.21 Tributary area for shear on an interior beam

6.5.6.8.2 In proportioning beams with $\alpha_{f1}l_2/l_1$ less than 1.0 to resist shear, linear interpolation, assuming beams carry no load at $\alpha_{f1} = 0$, shall be permitted.

6.5.6.8.3 In addition to shears calculated according to Sections 6.5.6.8.1 and 6.5.6.8.2, beams shall be proportioned to resist shears caused by factored loads applied directly on beams.

6.5.6.8.4 Computation of slab shear strength on the assumption that load is distributed to supporting beams in accordance with Sec 6.5.6.8.1 or Sec 6.5.6.8.2 shall be permitted. Resistance to total shear occurring on a panel shall be provided.

6.5.6.8.5 Shear strength shall satisfy the requirements of Sec. 6.4.

6.5.6.9 Factored moments in columns and walls

6.5.6.9.1 Columns and walls built integrally with a slab system shall resist moments caused by factored loads on the slab system.

6.5.6.9.2 At an interior support, supporting elements above and below the slab shall resist the factored moment specified by Eq. 6.6.87 in direct proportion to their stiffnesses unless a general analysis is made.

$$M_u = 0.07[(q_{Du} + 0.5q_{Lu})l_2l_n^2 - q'_{Du}l'_2(l'_n)^2] \quad (6.6.87)$$

Where, q'_{Du} , l'_2 , and l'_n refer to shorter span.

6.5.7 Equivalent Frame Method

6.5.7.1 Design of slab systems by the equivalent frame method shall be based on assumptions given in Sections 6.5.7.2 to 6.5.7.6, and all sections of slabs and supporting members shall be proportioned for moments and shears thus obtained.

6.5.7.1.1 Where metal column capitals are used, it shall be permitted to take account of their contributions to stiffness and resistance to moment and to shear.

6.5.7.1.2 It shall be permitted to neglect the change in length of columns and slabs due to direct stress, and deflections due to shear.

6.5.7.2 Equivalent frame

6.5.7.2.1 The structure shall be considered to be made up of equivalent frames on column lines taken longitudinally and transversely through the building (Figure 6.6.22).

6.5.7.2.2 Each frame shall consist of a row of columns or supports and slab-beam strips, bounded laterally by the centerline of panel on each side of the center line of columns or supports.

6.5.7.2.3 Columns or supports shall be assumed to be attached to slab-beam strips by torsional members (see Sec 6.5.7.5) transverse to the direction of the span for which moments are being determined and extending to bounding lateral panel centerlines on each side of a column.

6.5.7.2.4 Frames adjacent and parallel to an edge shall be bounded by that edge and the centerline of adjacent panel.

6.5.7.2.5 Analysis of each equivalent frame in its entirety shall be permitted. Alternatively, for gravity loading, a separate analysis of each floor or roof with far ends of columns considered fixed shall be permitted.

6.5.7.2.6 Where slab-beams are analyzed separately, determination of moment at a given support assuming that the slab-beam is fixed at any support two panels distant therefrom, shall be permitted, provided the slab continues beyond that point.

6.5.7.3 Slab-beams

6.5.7.3.1 Determination of the moment of inertia of slab-beams at any cross section outside of joints or column capitals using the gross area of concrete shall be permitted.

6.5.7.3.2 Variation in moment of inertia along axis of slab-beams shall be taken into account.

6.5.7.3.3 Moment of inertia of slab-beams from center of column to face of column, bracket, or capital shall be assumed equal to the moment of inertia of the slab-beam at face of column, bracket, or capital divided by the quantity $(1 - c_2 / l_2)^2$ where c_2 and l_2 are measured transverse to the direction of the span for which moments are being determined.

6.5.7.4 Columns

6.5.7.4.1 Determination of the moment of inertia of columns at any cross section outside of joints or column capitals using the gross area of concrete shall be permitted.

6.5.7.4.2 Variation in moment of inertia along axis of columns shall be taken into account (Figure 6.6.23).

6.5.7.4.3 Moment of inertia of columns from top to bottom of the slab-beam at a joint shall be assumed to be infinite.

6.5.7.5 Torsional members

6.5.7.5.1 Torsional members (see Sec 6.5.7.2.3) shall be assumed to have a constant cross section throughout their length consisting of the largest of (a), (b), and (c):

- (a) A portion of slab having a width equal to that of the column, bracket, or capital in the direction of the span for which moments are being determined;
- (b) For monolithic or fully composite construction, the portion of slab specified in (a) plus that part of the transverse beam above and below the slab;
- (c) The transverse beam as defined in Sec 6.5.2.4.

6.5.7.5.2 Where beams frame into columns in the direction of the span for which moments are being determined, the torsional stiffness shall be multiplied by the ratio of the moment of inertia of the slab with such a beam to the moment of inertia of the slab without such a beam.

6.5.7.5.3 Stiffness K_t of the torsional members shall be calculated by the following expression:

$$K_t = \sum \frac{9E_{cs}C}{l_2(1-c_2/l_2)^3} \quad (6.6.88)$$

Where, c_2 and l_2 relate to the transverse span on each side of column.

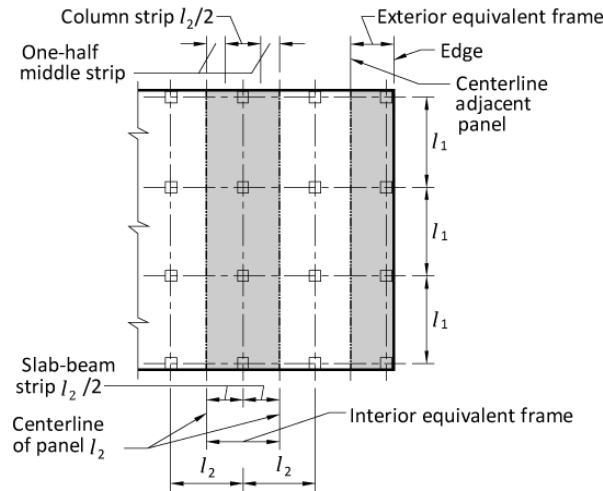


Figure 6.6.22 Definitions of equivalent frame.

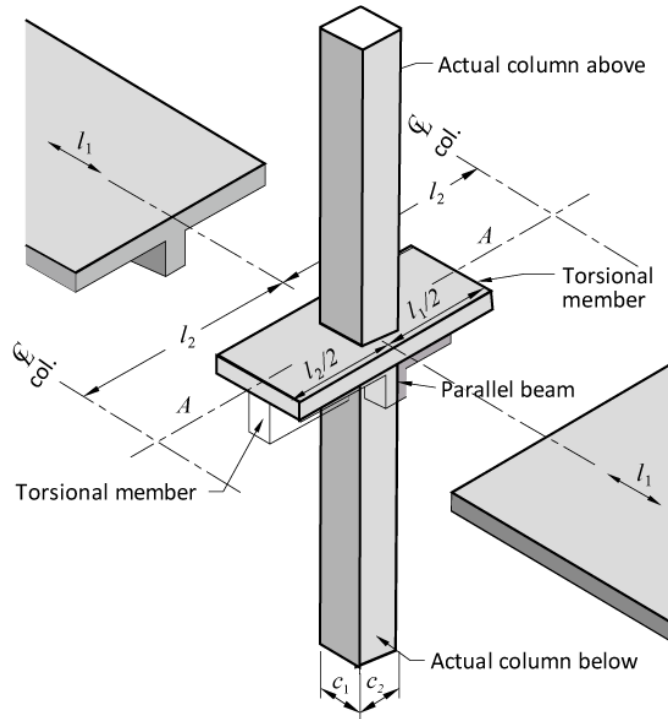


Figure 6.6.23 Equivalent column (column plus torsional members).

6.5.7.6 Arrangement of live load

6.5.7.6.1 When the loading pattern is known, the equivalent frame shall be analyzed for that load.

6.5.7.6.2 When the unfactored live load is variable but does not exceed three-quarters of the unfactored dead load, or the nature of live load is such that all panels will be loaded simultaneously, it shall be permitted to assume that maximum factored moments occur at all sections with full factored live load on entire slab system.

6.5.7.6.3 For loading conditions other than those defined in Sec 6.5.7.6.2, it shall be permitted to assume that maximum positive factored moment near mid span of a panel occurs with three-quarters of the full factored live load on the panel and on alternate panels; and it shall be permitted to assume that maximum negative factored moment in the slab at a support occurs with three-quarters of the full factored live load on adjacent panels only.

6.5.7.6.4 Factored moments shall be taken not less than those occurring with full factored live load on all panels.

6.5.7.7 Factored moments

6.5.7.7.1 At interior supports, the critical section for negative factored moment (in both column and middle strips) shall be taken at face of rectilinear supports, but not farther away than $0.175l_1$ from the center of a column.

6.5.7.7.2 At exterior supports with brackets or capitals, the critical section for negative factored moment in the span perpendicular to an edge shall be taken at a distance from face of supporting element not greater than one-half the projection of bracket or capital beyond face of supporting element.

6.5.7.7.3 Circular or regular polygon-shaped supports shall be treated as square supports with the same area for location of critical section for negative design moment.

6.5.7.7.4 Where slab systems within limitations of Sec 6.5.6.1 are analyzed by the equivalent frame method, it shall be permitted to reduce the resulting computed moments in such proportion that the absolute sum of the positive and average negative moments used in design need not exceed the value obtained from Eq. 6.6.84.

6.5.7.7.5 Distribution of moments at critical sections across the slab-beam strip of each frame to column strips, beams, and middle strips as provided in Sections 6.5.6.4 to 6.5.6.6 shall be permitted if the requirement of Sec 6.5.6.1.6 is satisfied.

6.5.8 Alternative Design of Two-Way Edge-Supported Slabs

6.5.8.1 General

The design method described in this Section shall be based on assumptions given in Sec 6.5.8.2 and 6.5.8.3, and all sections of slabs and supporting members shall be proportioned for moments and shears thus obtained.

6.5.8.2 Scope and limitations

6.5.8.2.1 The provisions of this section may be used as alternative to those of Sections 6.5.1 to 6.5.7 for two-way slabs supported on all four edges by walls, steel beams or monolithic concrete beams having a total depth not less than 3 times the slab thickness.

6.5.8.2.2 Panels shall be rectangular with a longer to shorter centre to centre support span ratio of not greater than 2.

6.5.8.2.3 The value of $\left(\frac{\alpha_f l_2}{l_1}\right)$ shall be greater than or equal to 1.

6.5.8.3 Analysis by the Coefficient Method










6.5.8.3.1 The negative moments and dead load and live load positive moments in the two directions shall be computed from Tables 6.6.8, 6.6.9 and 6.6.10 respectively. Shear in the slab and loads on the supporting beams shall be computed from Table 6.6.11.

Table 6.6.8: Coefficients for Negative Moments in Slabs †

$$M_{a,neg} = C_{a,neg} w l_a^2$$

$$M_{b,neg} = C_{b,neg} w l_b^2$$

Where, w = total uniform dead plus live load per unit area

Span Ratio, $m = \frac{l_a}{l_b}$	Moment Coefficient	Case 1	Case 2	Case 3	Case 4	Case 5	Case 6	Case 7	Case 8	Case 9
										
1.00	$C_{a,neg}$		0.045		0.050	0.075	0.071		0.033	0.061
	$C_{b,neg}$		0.045	0.076	0.050			0.071	0.061	0.033
0.95	$C_{a,neg}$		0.050		0.055	0.079	0.075		0.038	0.065
	$C_{b,neg}$		0.041	0.072	0.045			0.067	0.056	0.029
0.90	$C_{a,neg}$		0.055		0.060	0.080	0.079		0.043	0.068
	$C_{b,neg}$		0.037	0.070	0.040			0.062	0.052	0.025
0.85	$C_{a,neg}$		0.060		0.066	0.082	0.083		0.049	0.072
	$C_{b,neg}$		0.031	0.065	0.034			0.057	0.046	0.021
0.80	$C_{a,neg}$		0.065		0.071	0.083	0.086		0.055	0.075
	$C_{b,neg}$		0.027	0.061	0.029			0.051	0.041	0.017

Span Ratio, $m = \frac{l_a}{l_b}$	Moment Coefficient	Case 1	Case 2	Case 3	Case 4	Case 5	Case 6	Case 7	Case 8	Case 9
0.75	$C_{a,neg}$		0.069		0.076	0.085	0.088		0.061	0.078
	$C_{b,neg}$		0.022	0.056	0.024			0.044	0.036	0.014
0.70	$C_{a,neg}$		0.074		0.081	0.086	0.091		0.068	0.081
	$C_{b,neg}$		0.017	0.050	0.019			0.038	0.029	0.011
0.65	$C_{a,neg}$		0.077		0.085	0.087	0.093		0.074	0.083
	$C_{b,neg}$		0.014	0.043	0.015			0.031	0.024	0.008
0.60	$C_{a,neg}$		0.081		0.089	0.088	0.095		0.080	0.085
	$C_{b,neg}$		0.010	0.035	0.011			0.024	0.018	0.006
0.55	$C_{a,neg}$		0.084		0.092	0.089	0.096		0.085	0.086
	$C_{b,neg}$		0.007	0.028	0.008			0.019	0.014	0.005
0.50	$C_{a,neg}$		0.086		0.094	0.090	0.097		0.089	0.088
	$C_{b,neg}$		0.006	0.022	0.006			0.014	0.010	0.003
† A crosshatched edge indicates that the slab continues across, or is fixed at the support; an unmarked edge indicates a support at which torsional resistance is negligible.										










Table 6.6.9: Coefficients for Dead Load Positive Moments in Slabs †

$$M_{a,pos,dl} = C_{a,dl} w l_a^2$$

$$M_{b,pos,dl} = C_{b,dl} w l_b^2$$

Where, w = uniform dead load per unit area

Span Ratio, $m = \frac{l_a}{l_b}$	Moment Coefficient	Case 1	Case 2	Case 3	Case 4	Case 5	Case 6	Case 7	Case 8	Case 9
1.00	$C_{a,dl}$	0.036	0.018	0.018	0.027	0.027	0.033	0.027	0.020	0.023
	$C_{b,dl}$	0.036	0.018	0.027	0.027	0.018	0.027	0.033	0.023	0.020










Span Ratio, $m = \frac{l_a}{l_b}$	Moment Coefficient	Case 1	Case 2	Case 3	Case 4	Case 5	Case 6	Case 7	Case 8	Case 9
										
0.95	$C_{a,dl}$	0.040	0.020	0.021	0.030	0.028	0.036	0.031	0.022	0.024
	$C_{b,dl}$	0.033	0.016	0.025	0.024	0.015	0.024	0.031	0.021	0.017
0.90	$C_{a,dl}$	0.045	0.022	0.025	0.033	0.029	0.039	0.035	0.025	0.026
	$C_{b,dl}$	0.029	0.014	0.024	0.022	0.013	0.021	0.028	0.019	0.015
0.85	$C_{a,dl}$	0.050	0.024	0.029	0.036	0.031	0.042	0.040	0.029	0.028
	$C_{b,dl}$	0.026	0.012	0.022	0.019	0.011	0.017	0.025	0.017	0.013
0.80	$C_{a,dl}$	0.056	0.026	0.034	0.039	0.032	0.045	0.045	0.032	0.029
	$C_{b,dl}$	0.023	0.011	0.020	0.016	0.009	0.015	0.022	0.015	0.010
0.75	$C_{a,dl}$	0.061	0.028	0.040	0.043	0.033	0.048	0.051	0.036	0.031
	$C_{b,dl}$	0.019	0.009	0.018	0.013	0.007	0.012	0.020	0.013	0.007
0.70	$C_{a,dl}$	0.068	0.030	0.046	0.046	0.035	0.051	0.058	0.040	0.033
	$C_{b,dl}$	0.016	0.007	0.016	0.011	0.005	0.009	0.017	0.011	0.006
0.65	$C_{a,dl}$	0.074	0.032	0.054	0.050	0.036	0.054	0.065	0.044	0.034
	$C_{b,dl}$	0.013	0.006	0.014	0.009	0.004	0.007	0.014	0.009	0.005
0.60	$C_{a,dl}$	0.081	0.034	0.062	0.053	0.037	0.056	0.073	0.048	0.036
	$C_{b,dl}$	0.010	0.004	0.011	0.007	0.003	0.006	0.012	0.007	0.004
0.55	$C_{a,dl}$	0.088	0.035	0.071	0.056	0.038	0.058	0.081	0.052	0.037
	$C_{b,dl}$	0.008	0.003	0.009	0.005	0.002	0.004	0.009	0.005	0.003
0.50	$C_{a,dl}$	0.095	0.037	0.080	0.059	0.039	0.061	0.089	0.056	0.038
	$C_{b,dl}$	0.006	0.002	0.007	0.004	0.001	0.003	0.007	0.004	0.002

† A crosshatched edge indicates that the slab continues across, or is fixed at the support; an unmarked edge indicates a support at which torsional resistance is negligible.

Table 6.6.10: Coefficients for Live Load Positive Moments in Slabs †










$$M_{a,pos,ll} = C_{a,ll} w l_a^2$$

$$M_{b,pos,ll} = C_{b,ll} w l_b^2 \text{ Where, } w = \text{uniform live load per unit area}$$

Span Ratio, $m = \frac{l_a}{l_b}$	Moment Coefficient	Case 1	Case 2	Case 3	Case 4	Case 5	Case 6	Case 7	Case 8	Case 9
										
1.00	$C_{a,ll}$	0.036	0.027	0.027	0.032	0.032	0.035	0.032	0.028	0.030
	$C_{b,ll}$	0.036	0.027	0.032	0.032	0.027	0.032	0.035	0.030	0.028
0.95	$C_{a,ll}$	0.040	0.030	0.031	0.035	0.034	0.038	0.036	0.031	0.032
	$C_{b,ll}$	0.033	0.025	0.029	0.029	0.024	0.029	0.032	0.027	0.025
0.90	$C_{a,ll}$	0.045	0.034	0.035	0.039	0.037	0.042	0.040	0.035	0.036
	$C_{b,ll}$	0.029	0.022	0.027	0.026	0.021	0.025	0.029	0.024	0.022
0.85	$C_{a,ll}$	0.050	0.037	0.040	0.043	0.041	0.046	0.045	0.040	0.039
	$C_{b,ll}$	0.026	0.019	0.024	0.023	0.019	0.022	0.026	0.022	0.020
0.80	$C_{a,ll}$	0.056	0.041	0.045	0.048	0.044	0.051	0.051	0.044	0.042
	$C_{b,ll}$	0.023	0.017	0.022	0.020	0.016	0.019	0.023	0.019	0.017
0.75	$C_{a,ll}$	0.061	0.045	0.051	0.052	0.047	0.055	0.056	0.049	0.046
	$C_{b,ll}$	0.019	0.014	0.019	0.016	0.013	0.016	0.020	0.016	0.013
0.70	$C_{a,ll}$	0.068	0.049	0.057	0.057	0.051	0.060	0.063	0.054	0.050
	$C_{b,ll}$	0.016	0.012	0.016	0.014	0.011	0.013	0.017	0.014	0.011
0.65	$C_{a,ll}$	0.074	0.053	0.064	0.062	0.055	0.064	0.070	0.059	0.054
	$C_{b,ll}$	0.013	0.010	0.014	0.011	0.009	0.010	0.014	0.011	0.009
0.60	$C_{a,ll}$	0.081	0.058	0.071	0.067	0.059	0.068	0.077	0.065	0.059
	$C_{b,ll}$	0.010	0.007	0.011	0.009	0.007	0.008	0.011	0.009	0.007
0.55	$C_{a,ll}$	0.088	0.062	0.080	0.072	0.063	0.073	0.085	0.070	0.063
	$C_{b,ll}$	0.008	0.006	0.009	0.007	0.005	0.006	0.009	0.007	0.006
0.50	$C_{a,ll}$	0.095	0.066	0.088	0.077	0.067	0.078	0.092	0.076	0.067
	$C_{b,ll}$	0.006	0.004	0.007	0.005	0.004	0.005	0.007	0.005	0.004

† A crosshatched edge indicates that the slab continues across, or is fixed at the support; an unmarked edge indicates a support at which torsional resistance is negligible.

Table 6.6.11: Ratio of Total Load w in l_a and l_b Directions (W_a and W_b) for Shear in Slab and Load on Supports †

Span Ratio, $m = \frac{l_a}{l_b}$	Load Ratio	Case 1	Case 2	Case 3	Case 4	Case 5	Case 6	Case 7	Case 8	Case 9
										
1.00	w_a	0.50	0.50	0.17	0.50	0.83	0.71	0.29	0.33	0.67
	w_b	0.50	0.50	0.83	0.50	0.17	0.29	0.71	0.67	0.33
0.95	w_a	0.55	0.55	0.20	0.55	0.86	0.75	0.33	0.38	0.71
	w_b	0.45	0.45	0.80	0.45	0.14	0.25	0.67	0.62	0.29
0.90	w_a	0.60	0.60	0.23	0.60	0.88	0.79	0.38	0.43	0.75
	w_b	0.40	0.40	0.77	0.40	0.12	0.21	0.62	0.57	0.25
0.85	w_a	0.66	0.66	0.28	0.66	0.90	0.83	0.43	0.49	0.79
	w_b	0.34	0.34	0.72	0.34	0.10	0.17	0.57	0.51	0.21
0.80	w_a	0.71	0.71	0.33	0.71	0.92	0.86	0.49	0.55	0.83
	w_b	0.29	0.29	0.67	0.29	0.08	0.14	0.51	0.45	0.17
0.75	w_a	0.76	0.76	0.39	0.76	0.94	0.88	0.56	0.61	0.86
	w_b	0.24	0.24	0.61	0.24	0.06	0.12	0.44	0.39	0.14
0.70	w_a	0.81	0.81	0.45	0.81	0.95	0.91	0.62	0.68	0.89
	w_b	0.19	0.19	0.55	0.19	0.05	0.09	0.38	0.32	0.11
0.65	w_a	0.85	0.85	0.53	0.85	0.96	0.93	0.69	0.74	0.92
	w_b	0.15	0.15	0.47	0.15	0.04	0.07	0.31	0.26	0.08
0.60	w_a	0.89	0.89	0.61	0.89	0.97	0.95	0.76	0.80	0.94
	w_b	0.11	0.11	0.39	0.11	0.03	0.05	0.24	0.20	0.06
0.55	w_a	0.92	0.92	0.69	0.92	0.98	0.96	0.81	0.85	0.95
	w_b	0.08	0.08	0.31	0.08	0.02	0.04	0.19	0.15	0.05
0.50	w_a	0.94	0.94	0.76	0.94	0.99	0.97	0.86	0.89	0.97
	w_b	0.06	0.06	0.24	0.06	0.01	0.03	0.14	0.11	0.03

† A crosshatched edge indicates that the slab continues across, or is fixed at the support; an unmarked edge indicates a support at which torsional resistance is negligible.

6.5.8.4 Shear on Supporting Beam

The shear requirements provided in Sec 6.5.6.8 shall be satisfied.

6.5.8.5 Deflection

Thickness of slabs supported on walls or stiff beams on all sides shall satisfy the requirements of Sec 6.2.5.3.

6.5.8.6 Reinforcement

6.5.8.6.1 Area of reinforcement in each direction shall be determined from moments at critical sections but shall not be less than that required by Sec 8.1.11 Chapter 8.

6.5.8.6.2 Spacing of reinforcement at critical sections shall not exceed two times the slab thickness, except for portions of slab area that may be of cellular or ribbed construction. In the slab over cellular spaces, reinforcement shall be provided as required by Sec 8.1.11 Chapter 8.

6.5.8.6.3 Positive moment reinforcement perpendicular to a discontinuous edge shall extend to the edge of slab and have embedment, straight or hooked, at least 150 mm in spandrel beams, columns, or walls.

6.5.8.6.4 Negative moment reinforcement perpendicular to a discontinuous edge shall be bent, hooked, or otherwise anchored, in spandrel beams, columns, or walls, and shall be developed at face of support according to provisions of Sec 8.2 Chapter 8.

6.5.8.6.5 Corner reinforcement

Corner reinforcement shall be provided at exterior corners in both bottom and top of the slab, for a distance in each direction from the corner equal to one-fifth the longer span of the corner panel as per provisions of Sec 6.5.3.6.

6.5.9 Ribbed and Hollow Slabs

6.5.9.1 General

The provisions of this section shall apply to slabs constructed in one of the ways described below:

- (a) As a series of concrete ribs with topping cast on forms which may be removed after the concrete has set;
- (b) As a series of concrete ribs between precast blocks which remain part of the completed structure; the top of the ribs may be connected by a topping of concrete of the same strength as that used in the ribs;
- (c) Slabs with a continuous top and bottom face but containing voids of rectangular, oval or other shape.

6.5.9.2 Analysis and design

Any method of analysis which satisfies equilibrium and compatibility requirements may be used for ribbed and hollow slabs. Approximate moments and shears in continuous one-way ribbed or hollow slabs may be obtained from Sec 6.1.4.3. For two-way slabs, the unified design approach specified in Sec 6.5 Flat Plates, Flat Slabs and Edge-supported Slabs, shall be used.

6.5.9.3 Shear

6.5.9.3.1 When burnt tile or concrete tile fillers of material having the same strength as the specified strength of concrete in the ribbed and hollow slabs are used permanently, it is permitted to include the vertical shells of fillers in contact with the ribs for shear and negative-moment strength computations, provided adequate bond between the two can be ensured.

6.5.9.4 Deflection

The recommendations for deflection with respect to solid slabs may be applied to ribbed and hollow slab. Total depth of one-way ribbed and hollow slabs shall not be less than those required by Table 6.6.1 in Sec 6.2.5.2. For other slabs the provisions of Sec 6.2.5.3 shall apply.

6.5.9.5 Size and Position of Ribs

In-situ-ribs shall be not less than 100 mm wide. They shall be spaced at centres not greater than 750 mm apart and their depth, excluding any topping, shall be not more than three and half times their width. Ribs shall be formed along each edge parallel to the span of one-way slabs.

6.5.9.6 Reinforcement

The recommendations given in Sec 8.1.6 Chapter 8 regarding maximum distance between bars apply to areas of solid concrete in this form of construction. The curtailment, anchorage and cover to reinforcement shall be as specified below:

- (a) At least 50 percent of the total main reinforcement shall be carried through the bottom on to the bearing and anchored in accordance with Sec 8.2.8 Chapter 8.
- (b) Where a slab, which is continuous over supports, has been designed as simply supported, reinforcement shall be provided over the support to control cracking. This reinforcement shall have a cross-sectional area of not less than one quarter of that required in the middle of the adjoining spans and shall extend at least one-tenth of the clear span into adjoining spans.

In slabs with permanent blocks, the side cover to the reinforcement shall not be less than 10 mm. In all other cases, cover shall be provided according to Sec 8.1.7 Chapter 8.

6.5.9.6.1 Adequate shear strength of slabs shall be provided in accordance with the requirements of Sec 6.4.10. For one-way ribbed and hollow slab construction, contribution of concrete to shear strength V_c is permitted to be 10 percent more than that specified in Sec 6.4.2. It is permitted to increase shear strength using shear reinforcement or by widening the ends of ribs.

6.6 Walls

6.6.1 Scope

6.6.1.1 Provisions of Sec. 6.6 shall apply for design of walls subjected to axial load, with or without flexure.

6.6.1.2 Cantilever retaining walls are designed according to flexural design provisions of Sec 6.3 with minimum horizontal reinforcement according to Sec 6.6.3.3.

6.6.2 General

6.6.2.1 Walls shall be designed for eccentric loads and any lateral or other loads to which they are subjected.

6.6.2.2 Walls subject to axial loads shall be designed in accordance with Sections 6.6.2, 6.6.3, and either Sec 6.6.4, Sec 6.6.5, or Sec 6.6.8.

6.6.2.3 Design for shear shall be in accordance with Sec 6.4.8.

6.6.2.4 Unless otherwise demonstrated by an analysis, the horizontal length of wall considered as effective for each concentrated load shall not exceed the smaller of the center-to-center distance between loads, and the bearing width plus four times the wall thickness.

6.6.2.5 Compression members built integrally with walls shall conform to Sec 6.3.8.2.

6.6.2.6 Walls shall be anchored to intersecting elements, such as floors and roofs; or to columns pilasters, buttresses, of intersecting walls; and to footings.

6.6.2.7 Quantity of reinforcement and limits of thickness required by Sections 6.6.3 and 6.6.5 shall be permitted to be waived where structural analysis shows adequate strength and stability.

6.6.2.8 Transfer of force to footing at base of wall shall be in accordance with Sec 6.8.8.

6.6.3 Minimum reinforcement

6.6.3.1 Minimum vertical and horizontal reinforcement shall be in accordance with Sections 6.6.3.2 and 6.6.3.3 unless a greater amount is required for shear by Sections 6.4.8.8 and 6.4.8.9.

6.6.3.2 Minimum ratio of vertical reinforcement area to gross concrete area, ρ_l , shall be:

- (a) 0.0012 for deformed bars not larger than 16 mm diameter with f_y not less than 420 MPa; or
- (b) 0.0015 for other deformed bars; or
- (c) 0.0012 for welded wire reinforcement not larger than MW200 or MD200.

6.6.3.3 Minimum ratio of horizontal reinforcement area to gross concrete area, ρ_t , shall be:

- (a) 0.0020 for deformed bars not larger than 16 mm diameter with f_y not less than 420 MPa; or
- (b) 0.0025 for other deformed bars; or
- (c) 0.0020 for welded wire reinforcement not larger than MW200 or MD200.

6.6.3.4 Walls more than 250 mm thick, except basement walls, shall have reinforcement for each direction placed in two layers parallel with faces of wall in accordance with the following:

- (a) One layer consisting of not less than one-half and not more than two-thirds of total reinforcement required for each direction shall be placed not less than 50 mm nor more than one-third the thickness of wall from the exterior surface;
- (b) The other layer, consisting of the balance of required reinforcement in that direction, shall be placed not less than 20 mm nor more than one-third the thickness of wall from the interior surface.

6.6.3.5 Vertical and horizontal reinforcement shall not be spaced farther apart than three times the wall thickness, nor farther apart than 450 mm.

6.6.3.6 Vertical reinforcement need not be enclosed by lateral ties if vertical reinforcement area is not greater than 0.01 times gross concrete area, or where vertical reinforcement is not required as compression reinforcement.

6.6.3.7 In addition to the minimum reinforcement required by Sec 6.6.3.1, not less than two 16 mm diameter bars in walls having two layers of reinforcement in both directions and one 16 mm diameter bar in walls having a single layer of reinforcement in both directions shall be provided around window, door, and similar sized openings. Such bars shall be anchored to develop f_y in tension at the corners of the openings.

6.6.4 Design of Walls as Compression Members

Except as provided in Sec 6.6.5, walls subject to axial load or combined flexure and axial load shall be designed as compression members in accordance with provisions of Sections 6.3.2, 6.3.3, 6.3.10, 6.3.11, 6.3.14, 6.6.2, and 6.6.3.

6.6.5 Empirical Method of Design

6.6.5.1 Walls of solid rectangular cross section shall be permitted to be designed by the empirical provisions of Sec 6.6.5 if the resultant of all factored loads is located within the middle third of the overall thickness of the wall and all limits of Sections 6.6.2, 6.6.3, and 6.6.5 are satisfied.

6.6.5.2 Design axial strength ϕP_n of a wall satisfying limitations of Sec 6.6.5.1 shall be computed by Eq. 6.6.89 unless designed in accordance with 6.6.4.

$$\phi P_n = 0.55\phi f'_c A_g \left[1 - \left(\frac{Kl_c}{32h} \right)^2 \right] \quad (6.6.89)$$

Where, ϕ shall correspond to compression-controlled sections in accordance with Sec 6.2.3.2.2 and effective length factor k shall be:

- | | |
|---|-----|
| (a) For walls braced top and bottom against lateral translation and
Restrained against rotation at one or both ends (top, bottom, or 0.8
Unrestrained against rotation at both ends | 1.0 |
| (b) For walls not braced against lateral translation | 2.0 |

6.6.5.3 Minimum thickness of walls designed by empirical design method

6.6.5.3.1 Thickness of bearing walls shall not be less than 1/25 the supported height or length, whichever is shorter, nor less than 100 mm.

6.6.5.3.2 Thickness of exterior basement walls and foundation walls shall not be less than 190 mm.

6.6.6 Nonbearing Walls

6.6.6.1 Thickness of nonbearing walls shall not be less than 100 mm, nor less than 1/30 the least distance between members that provide lateral support.

6.6.7 Walls as Grade Beams

6.6.7.1 Walls designed as grade beams shall have top and bottom reinforcement as required for moment in accordance with provisions of Sections 6.3.2 to 6.3.7. Design for shear shall be in accordance with provisions of Sec. 6.4.

6.6.7.2 Portions of grade beam walls exposed above grade shall also meet requirements of Sec 6.6.3.

6.6.8 Alternative Design of Slender Walls

6.6.8.1 When flexural tension controls the out-of-plane design of a wall, the requirements of Sec 6.6.8 are considered to satisfy Sec 6.3.10.

6.6.8.2 Walls designed by the provisions of Sec 6.6.8 shall satisfy Sections 6.6.8.2.1 to 6.6.8.2.6.

6.6.8.2.1 The wall panel shall be designed as a simply supported, axially loaded member subjected to an out-of-plane uniform lateral load, with maximum moments and deflections occurring at midspan.

6.6.8.2.2 The cross section shall be constant over the height of the panel.

6.6.8.2.3 The wall shall be tension-controlled.

6.6.8.2.4 Reinforcement shall provide a design Strength

$$\phi M_n \geq M_{cr} \quad (6.6.90)$$

Where, M_{cr} shall be obtained using the modulus of rupture, f_r , given by Eq. 6.6.91.

6.6.8.2.5 Concentrated gravity loads applied to the wall above the design flexural section shall be assumed to be distributed over a width:

- Equal to the bearing width, plus a width on each side that increases at a slope of 2 vertical to 1 horizontal down to the design section; but
- Not greater than the spacing of the concentrated loads; and
- Not extending beyond the edges of the wall panel.

6.6.8.2.6 Vertical stress P_u / A_g at the midheight section shall not exceed $0.06f'_c$.

6.6.8.3 Design moment strength ϕM_n for combined flexure and axial loads at midheight shall be

$$\phi M_n \geq M_u \quad (6.6.91)$$

Where,

$$M_u = M_{ua} + P_u \Delta_u \quad (6.6.92)$$

M_{ua} is the maximum factored moment at midheight of wall due to lateral and eccentric vertical loads, not including $P\Delta$ effects, and Δ_u is

$$\Delta_u = \frac{5M_u l_c^2}{(0.75)48E_c I_{cr}} \quad (6.6.93)$$

M_u shall be obtained by iteration of deflections, or by Eq. 6.6.94.

$$M_u = \frac{M_{ua}}{1 - \frac{5P_u l_c^2}{(0.75)48E_c I_{cr}}} \quad (6.6.94)$$

Where,

$$I_{cr} = \frac{E_s}{E_c} \left(A_s + \frac{P_u h}{f_y} \right) (d - c)^2 + \frac{l_w c^3}{3} \quad (6.6.95)$$

And, the value of E_s/E_c shall not be taken less than 6.

6.6.8.4 Maximum out-of-plane deflection, Δ_s , due to service loads, including $P\Delta$ effects, shall not exceed $l_c/150$.

If M_a , maximum moment at midheight of wall due to service lateral and eccentric vertical loads, including $P\Delta$ effects, exceeds $(2/3)M_{cr}$, Δ_s shall be calculated by Eq. 6.6.96

$$\Delta_s = (2/3)\Delta_{cr} + \frac{(M_a - (2/3)M_{cr})}{(M_n - (2/3)M_{cr})} (\Delta_n - (2/3)\Delta_{cr}) \quad (6.6.96)$$

If M_a does not exceed $(2/3)M_{cr}$, Δ_s shall be calculated by Eq. 6.6.97

$$\Delta_s = \left(\frac{M_a}{M_{cr}} \right) \Delta_{cr} \quad (6.6.97)$$

Where,

$$\Delta_{cr} = \frac{5M_{cr}l_c^2}{48E_c I_g} \quad (6.6.98)$$

$$\Delta_n = \frac{5M_n l_c^2}{48E_c I_{cr}} \quad (6.6.99)$$

I_{cr} shall be calculated by Eq. 6.6.95, and M_a shall be obtained by iteration of deflections.

6.7 Stairs

Stairs are the structural elements designed to connect different floors. The stairs shall be designed to meet the minimum load requirements. The flight arrangements, configuration and support conditions (Figure 6.6.24) shall govern the design procedure to follow.

6.7.1 Stairs Supported at Floor and Landing Level

6.7.1.1 Effective span

The effective span of stairs without stringer beams shall be taken as the following horizontal distances:

- Centre to centre distance of beams, where supported at top and bottom risers by beams spanning parallel with the risers,
- Where supported at the edge of a landing slab, which spans parallel with the risers, (Figure 6.6.25a) a distance equal to the going of the stairs plus at each end either half the width of the landing or 1.0m whichever is smaller. The going shall be measured horizontally.

- (c) Where the landing spans in the same direction of the stairs (Figure 6.6.25b), the span shall be the distance centre to centre of the supporting beams or walls.
- (d) Where the landing slabs, running at right angle to the direction of the flight, supported by walls or beams on three sides (Figure 6.6.25c), the effective span shall be going of the stair measured horizontally. Both positive and negative moments along the direction of the flight shall be calculated as $wl^2/8$, where w is the intensity of the total dead and live load per unit area on a horizontal plane.

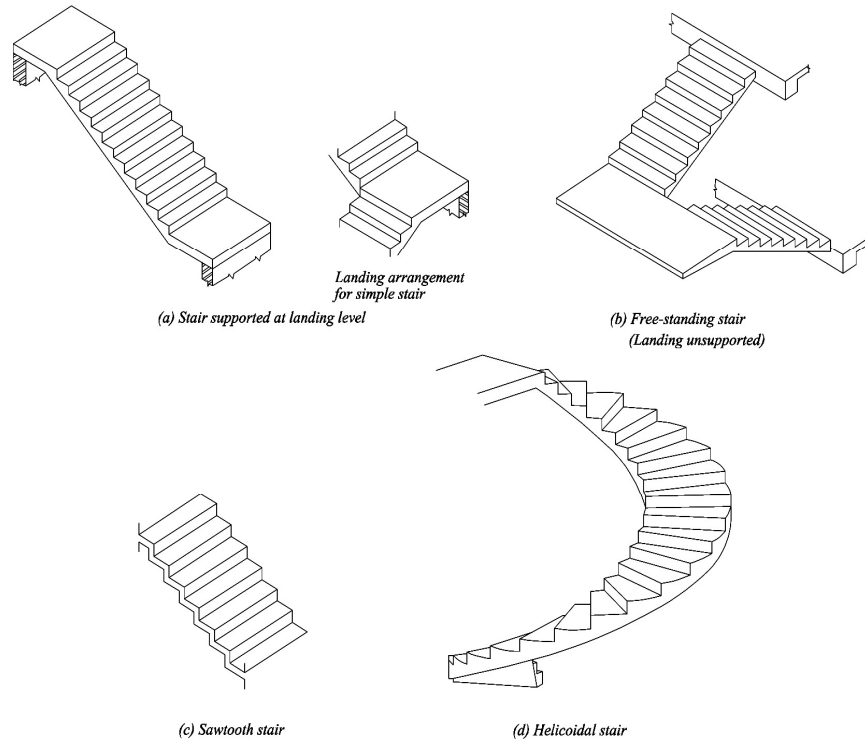


Figure 6.6.24 Different forms of stairs and landing arrangements

6.7.1.2 Loading

Staircases shall be designed to support the design ultimate load according to the load combinations specified in Chapter 2, loads.

6.7.1.3 Distribution of loading

6.7.1.3.1 Where flights or landing are embedded at least 110 mm into walls and are designed to span in the direction of the flight, a 150 mm strip may be deducted from the loaded area and the effective breadth of the section may be increased by 75 mm for the purpose of design (Figure 6.6.26)

In the case of stairs with open wells, where spans cross at right angles, the load on areas common to any two such spans may be taken as one half in each direction as shown in Figure 6.6.27.

6.7.1.4 Depth of section

The depth of the section shall be taken as the minimum thickness perpendicular to the soffit of the staircase.

6.7.1.5 Design

6.7.1.5.1 Strength, deflection and crack control

The recommendations given in Sections 6.1 and 6.2 for beams and one-way slabs shall apply, except for the span/depth ratio of staircases without stringer beam where the provision of Sec 6.7.1.5.2 below shall apply.

6.7.1.5.2 Permissible span/effective depth ratio for staircase without stringer beams: In case of stair flight that occupies at least 60% of the span, the ratio calculated in accordance with Sec 6.2.5.2 shall be increased by 15%.

6.7.2 Special Types of Stairs

The provisions of special types of stairs like Free Standing (Landing unsupported), Sawtooth (Slabless) and Helicoidal are provided in Appendix M.

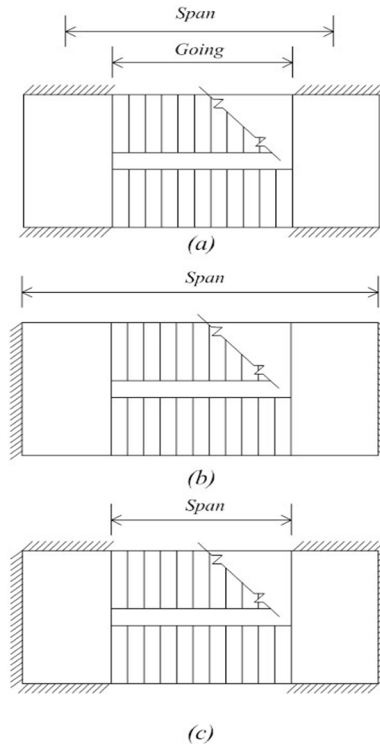


Figure 6.6.25 Effective Span for Stairs Supported at Each End by Landings

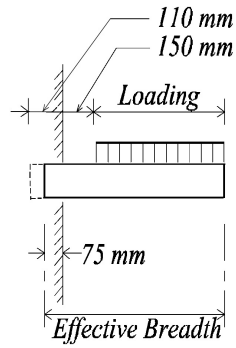


Figure 6.6.26 Loading on stairs Built in a wall

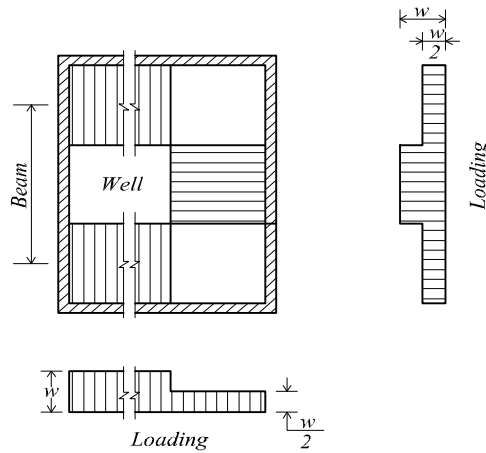


Figure 6.6.27 Loading of stairs with open wells

6.8 Footings

6.8.1 Scope

6.8.1.1 Provisions of Sec. 6.8 shall apply for design of isolated footings and, where applicable, to combined footings and mats.

6.8.1.2 Additional requirements for design of combined footings and mats are given in Sec 6.8.10.

6.8.2 Loads and Reactions

6.8.2.1 Footings shall be proportioned to resist the factored loads and induced reactions, in accordance with the appropriate design requirements of this Code and as provided in Sec. 6.8.

6.8.2.2 Base area of footing or number and arrangement of piles shall be determined from unfactored forces and moments transmitted by footing to soil or piles and permissible soil pressure or permissible pile capacity determined using principles of soil mechanics.

6.8.2.3 For footings on piles, computations for moments and shears shall be permitted to be based on the assumption that the reaction from any pile is concentrated at pile center.

6.8.3 Equivalent Square Shapes for Circular or Regular Polygon-Shaped Columns or Pedestals Supported By Footings

For location of critical sections for moment, shear, and development of reinforcement in footings, it shall be permitted to treat circular or regular polygon-shaped concrete columns or pedestals as square members with the same area.

6.8.4 Moment in Footings

6.8.4.1 External moment on any section of a footing shall be determined by passing a vertical plane through the footing, and computing the moment of the forces acting over entire area of footing on one side of that vertical plane.

6.8.4.2 Maximum factored moment, M_u , for an isolated footing shall be computed as prescribed in Sec 6.8.4.1 at critical sections located as follows:

- (a) At face of column, pedestal, or wall, for footings supporting a concrete column, pedestal, or wall;
- (b) Halfway between middle and edge of wall, for footings supporting a masonry wall;
- (c) Halfway between face of column and edge of steel base plate, for footings supporting a column with steel base plate.

6.8.4.3 In one-way footings and two-way square footings, reinforcement shall be distributed uniformly across entire width of footing.

6.8.4.4 In two-way rectangular footings, reinforcement shall be distributed in accordance with Sections 6.8.4.4.1 and 6.8.4.4.2.

6.8.4.4.1 Reinforcement in long direction shall be distributed uniformly across entire width of footing.

6.8.4.4.2 For reinforcement in short direction, a portion of the total reinforcement, $\gamma_s A_s$, shall be distributed uniformly over a band width (centered on centerline of column or pedestal) equal to the length of short side of footing. Remainder of reinforcement required in short direction $(1 - \gamma_s) A_s$, shall be distributed uniformly outside center band width of footing.

$$\gamma_s = \frac{2}{(\beta+1)} \quad (6.6.100)$$

Where, β is ratio of long to short sides of footing.

6.8.5 Shear in Footings

6.8.5.1 Shear strength of footings supported on soil or rock shall be in accordance with Sec 6.4.10.

6.8.5.2 Location of critical section for shear in accordance with Sec. 6.4 shall be measured from face of column, pedestal, or wall, for footings supporting a column, pedestal, or wall. For footings supporting a column or pedestal with steel base plates, the critical section shall be measured from location defined in Sec 6.8.4.2(c).

6.8.5.3 Where the distance between axis of any pile to the axis of the column is more than two times the distance between the top of the pile cap and the top of the pile, the pile cap shall satisfy Sections 6.4.10 and 6.8.5.4. Other pile caps shall satisfy either Appendix I, or both Sections 6.4.10 and 6.8.5.4. If Appendix I is used, the effective concrete compression strength of the struts, f_{ce} , shall be determined using Sec I.3.2.2(b).

6.8.5.4 Computation of shear on any section through a footing supported on piles (Figure 6.6.28) shall be in accordance with Sections 6.8.5.4.1, 6.8.5.4.2, and 6.8.5.4.3.

6.8.5.4.1 Entire reaction from any pile with its center located $\frac{d_{pile}}{2}$ or more outside the section shall be considered as producing shear on that section.

6.8.5.4.2 Reaction from any pile with its center located $\frac{d_{pile}}{2}$ or more inside the section shall be considered as producing no shear on that section.

6.8.5.4.3 For intermediate positions of pile center, the portion of the pile reaction to be considered as producing shear on the section shall be based on straight-line interpolation between full value at $\frac{d_{pile}}{2}$ outside the section and zero value at $\frac{d_{pile}}{2}$ inside the section.

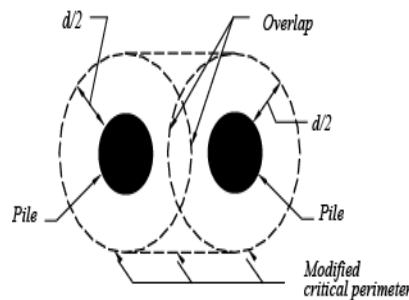


Figure 6.6.28 Modified critical perimeter for shear with over-lapping critical perimeters.

6.8.6 Development of Reinforcement in Footings

6.8.6.1 Development of reinforcement in footings shall be in accordance with Sec. 8.2.

6.8.6.2 Calculated tension or compression in reinforcement at each section shall be developed on each side of that section by embedment length, hook (tension only) or mechanical device, or a combination thereof.

6.8.6.3 Critical sections for development of reinforcement shall be assumed at the same locations as defined in 6.8.4.2 for maximum factored moment, and at all other vertical planes where changes of section or reinforcement occur. See also 8.2.7.6.

6.8.7 Minimum Footing Depth

Depth of footing above bottom reinforcement shall not be less than 150 mm for footings on soil, nor less than 300 mm for footings on piles.

6.8.8 Force Transfer at Base of Column, Wall, or Reinforced Pedestal

6.8.8.1 Forces and moments at base of column, wall, or pedestal shall be transferred to supporting pedestal or footing by bearing on concrete and by reinforcement, dowels, and mechanical connectors.

6.8.8.1.1 Bearing stress on concrete at contact surface between supported and supporting member shall not exceed concrete bearing strength for either surface as given by Sec 6.3.14.

6.8.8.1.2 Reinforcement, dowels, or mechanical connectors between supported and supporting members shall be adequate to transfer:

- (a) All compressive force that exceeds concrete bearing strength of either member;
- (b) Any computed tensile force across interface.

In addition, reinforcement, dowels, or mechanical connectors shall satisfy Sec 6.8.8.2 or Sec 6.8.8.3.

6.8.8.1.3 If calculated moments are transferred to supporting pedestal or footing, then reinforcement, dowels, or mechanical connectors shall be adequate to satisfy Sec 8.2.15.

6.8.8.1.4 Lateral forces shall be transferred to supporting pedestal or footing in accordance with shear-friction provisions of Sec 6.4.5, or by other appropriate means.

6.8.8.2 In cast-in-place construction, reinforcement required to satisfy Sec 6.8.8.1 shall be provided either by extending longitudinal bars into supporting pedestal or footing, or by dowels.

6.8.8.2.1 For cast-in-place columns and pedestals, area of reinforcement across interface shall be not less than $0.005A_g$, where A_g is the gross area of the supported member.

6.8.8.2.2 For cast-in-place walls, area of reinforcement across interface shall be not less than minimum vertical reinforcement given in Sec 6.6.3.2.

6.8.8.2.3 At footings, it shall be permitted to lap splice 43 mm diameter and 57 mm diameter longitudinal bars, in compression only, with dowels to provide reinforcement required to satisfy Sec 6.8.8.1. Dowels shall not be larger than 36 mm diameter bar and shall extend into supported member a distance not less than the larger of l_{dc} of 43 mm diameter or 57 mm diameter bars and compression lap splice length of the dowels, whichever is greater, and into the footing a distance not less than l_{dc} of the dowels.

6.8.8.2.4 If a pinned or rocker connection is provided in cast-in-place construction, connection shall conform to the provisions of Sections 6.8.8.1 and 6.8.8.3.

6.8.8.3 In precast construction, anchor bolts or suitable mechanical connectors shall be permitted for satisfying 6.8.8.1. Anchor bolts shall be designed in accordance with Appendix K.

6.8.8.3.1 Connection between precast columns or pedestals and supporting members shall meet the requirements of Sec 6.10.5.1.3(a).

6.8.8.3.2 Connection between precast walls and supporting members shall meet the requirements of Sec 6.10.5.1.3(b) and (c).

6.8.8.3.3 Anchor bolts and mechanical connections shall be designed to reach their design strength before anchorage failure or failure of surrounding concrete. Anchor bolts shall be designed in accordance with Appendix K.

6.8.9 Stepped or Sloped Footings

6.8.9.1 In sloped or stepped footings, angle of slope or depth and location of steps shall be such that design requirements are satisfied at every section. (See also Sec 8.2.7.6.)

6.8.9.2 Sloped or stepped footings designed as a unit shall be constructed to ensure action as a unit.

6.8.10 Combined Footings and Mats

6.8.10.1 Footings supporting more than one column, pedestal, or wall (combined footings or mats) shall be proportioned to resist the factored loads and induced reactions, in accordance with appropriate design requirements of the Code.

6.8.10.2 The direct design method of Sec. 6.5 shall not be used for design of combined footings and mats.

6.8.10.3 Distribution of soil pressure under combined footings and mats shall be consistent with properties of the soil and the structure and with established principles of soil mechanics.

6.8.10.4 Minimum reinforcing steel in mat foundations shall meet the requirements of Sec. 8.1.11.2 in each principal direction. Maximum spacing shall not exceed 450 mm.

6.9 Folded Plates and Shells**6.9.1 Scope and Definitions**

6.9.1.1 Provisions of Sec. 6.9 shall apply to thin shell and folded plate concrete structures, including ribs and edge members.

6.9.1.2 All provisions of this Code not specifically excluded, and not in conflict with provisions of Sec. 6.9, shall apply to thin-shell structures.

6.9.1.3 Thin shells

Three-dimensional spatial structures made up of one or more curved slabs or folded plates whose thicknesses are small compared to their other dimensions. Thin shells are characterized by their three-dimensional load-carrying behavior, which is determined by the geometry of their forms, by the manner in which they are supported, and by the nature of the applied load.

6.9.1.4 Folded plates

A class of shell structure formed by joining flat, thin slabs along their edges to create a three-dimensional spatial structure.

6.9.1.5 Ribbed shells

Spatial structures with material placed primarily along certain preferred rib lines, with the area between the ribs filled with thin slabs or left open.

6.9.1.6 Auxiliary members

Ribs or edge beams that serve to strengthen, stiffen, or support the shell; usually, auxiliary members act jointly with the shell.

6.9.1.7 Elastic analysis

An analysis of deformations and internal forces based on equilibrium, compatibility of strains, and assumed elastic behavior, and representing to a suitable approximation the three-dimensional action of the shell together with its auxiliary members.

6.9.1.8 Inelastic analysis

An analysis of deformations and internal forces based on equilibrium, nonlinear stress-strain relations for concrete and reinforcement, consideration of cracking and time-dependent effects, and compatibility of strains. The analysis shall represent to a suitable approximation three-dimensional action of the shell together with its auxiliary members.

6.9.1.9 Experimental analysis

An analysis procedure based on the measurement of deformations or strains, or both, of the structure or its model; experimental analysis is based on either elastic or inelastic behavior.

6.9.2 Analysis and Design

6.9.2.1 Elastic behavior shall be an accepted basis for determining internal forces and displacements of thin shells. This behavior shall be permitted to be established by computations based on an analysis of the uncracked concrete structure in which the material is assumed linearly elastic, homogeneous, and isotropic. Poisson's ratio of concrete shall be permitted to be taken equal to zero.

6.9.2.2 Inelastic analyses shall be permitted to be used where it can be shown that such methods provide a safe basis for design.

6.9.2.3 Equilibrium checks of internal resistances and external loads shall be made to ensure consistency of results.

6.9.2.4 Experimental or numerical analysis procedures shall be permitted where it can be shown that such procedures provide a safe basis for design.

6.9.2.5 Approximate methods of analysis shall be permitted where it can be shown that such methods provide a safe basis for design.

6.9.2.6 The thickness of a shell and its reinforcement shall be proportioned for the required strength and serviceability, using either the strength design method of Sec 6.1.2.1 or the design method of Sec 6.1.2.2.

6.9.2.7 Shell instability shall be investigated and shown by design to be precluded.

6.9.2.8 Auxiliary members shall be designed according to the applicable provisions of the Code. It shall be permitted to assume that a portion of the shell equal to the flange width, as specified in Sec 6.1.13, acts with the auxiliary member. In such portions of the shell, the reinforcement perpendicular to the auxiliary member shall be at least equal to that required for the flange of a T-beam by Sec 6.1.13.5.

6.9.2.9 Strength design of shell slabs for membrane and bending forces shall be based on the distribution of stresses and strains as determined from either an elastic or an inelastic analysis.

6.9.2.10 In a region where membrane cracking is predicted, the nominal compressive strength parallel to the cracks shall be taken as $0.4f'_c$.

6.9.3 Design Strength of Materials

6.9.3.1 Specified compressive strength of concrete f'_c at 28 days shall not be less than 21 MPa.

6.9.3.2 Specified yield strength of reinforcement f_y shall not exceed 420 MPa.

6.9.4 Shell Reinforcement

6.9.4.1 Shell reinforcement shall be provided to resist tensile stresses from internal membrane forces, to resist tension from bending and twisting moments, to limit shrinkage and temperature crack width and spacing, and as reinforcement at shell boundaries, load attachments, and shell openings.

6.9.4.2 Tensile reinforcement shall be provided in two or more directions and shall be proportioned such that its resistance in any direction equals or exceeds the component of internal forces in that direction. Alternatively, reinforcement for the membrane forces in the slab shall be calculated as the reinforcement required to resist axial tensile forces plus the tensile force due to shear-friction required to transfer shear across any cross section of the membrane. The assumed coefficient of friction, μ , shall not exceed that specified in Sec 6.4.5.4.3.

6.9.4.3 The area of shell reinforcement at any section as measured in two orthogonal directions shall not be less than the slab shrinkage or temperature reinforcement required by Sec 8.1.11.

6.9.4.4 Reinforcement for shear and bending moments about axes in the plane of the shell slab shall be calculated in accordance with Sections 6.3, 6.4 and 6.5.

6.9.4.5 The area of shell tension reinforcement shall be limited so that the reinforcement will yield before either crushing of concrete in compression or shell buckling can take place.

6.9.4.6 In regions of high tension, membrane reinforcement shall, if practical, be placed in the general directions of the principal tensile membrane forces. Where this is not practical, it shall be permitted to place membrane reinforcement in two or more component directions.

6.9.4.7 If the direction of reinforcement varies more than 10° from the direction of principal tensile membrane force, the amount of reinforcement shall be reviewed in relation to cracking at service loads.

6.9.4.8 Where the magnitude of the principal tensile membrane stress within the shell varies greatly over the area of the shell surface, reinforcement resisting the total tension shall be permitted to be concentrated in the regions of largest tensile stress where it can be shown that this provides a safe basis for design. However, the ratio of shell reinforcement in any portion of the tensile zone shall be not less than 0.0035 based on the overall thickness of the shell.

6.9.4.9 Reinforcement required to resist shell bending moments shall be proportioned with due regard to the simultaneous action of membrane axial forces at the same location. Where shell reinforcement is required in only one face to resist bending moments, equal amounts shall be placed near both surfaces of the shell even though a reversal of bending moments is not indicated by the analysis.

6.9.4.10 Shell reinforcement in any direction shall not be spaced farther apart than 450 mm nor farther apart than five times the shell thickness. Where the principal membrane tensile stress on the gross concrete area due to factored loads exceeds $0.33\phi\lambda\sqrt{f'_c}$, reinforcement shall not be spaced farther apart than three times the shell thickness.

6.9.4.11 Shell reinforcement at the junction of the shell and supporting members or edge members shall be anchored in or extended through such members in accordance with the requirements of Sec. 8.2, except that the minimum development length shall be $1.2l_d$ but not less than 450 mm.

6.9.4.12 Splice lengths of shell reinforcement shall be governed by the provisions of Sec. 8.2, except that the minimum splice length of tension bars shall be 1.2 times the value required by Sec. 8.2 but not less than 450 mm. The number of splices in principal tensile reinforcement shall be kept to a practical minimum. Where splices are necessary they shall be staggered at least l_d with not more than one-third of the reinforcement spliced at any section.

6.9.5 Construction

6.9.5.1 When removal of formwork is based on a specific modulus of elasticity of concrete because of stability or deflection considerations, the value of the modulus of elasticity, E_c , used shall be determined from flexural tests of field-cured beam specimens. The number of test specimens, the dimensions of test beam specimens, and test procedures shall be specified by the Engineer.

6.9.5.2 Contract documents shall specify the tolerances for the shape of the shell. If construction results in deviations from the shape greater than the specified tolerances, an analysis of the effect of the deviations shall be made and any required remedial actions shall be taken to ensure safe behavior.

6.10 Precast Concrete**6.10.1 Scope**

6.10.1.1 All provisions of this Code, not specifically excluded and not in conflict with the provisions of Sec 6.10, shall apply to structures incorporating precast concrete structural members.

6.10.2 General

6.10.2.1 Design of precast members and connections shall include loading and restraint conditions from initial fabrication to end use in the structure, including form removal, storage, transportation, and erection.

6.10.2.2 When precast members are incorporated into a structural system, the forces and deformations occurring in and adjacent to connections shall be included in the design.

6.10.2.3 Tolerances for both precast members and interfacing members shall be specified. Design of precast members and connections shall include the effects of these tolerances.

6.10.2.4 In addition to the requirements for drawings and specifications in Sec 1.9.3 of Chapter 1, the following (a) and (b) shall be included in either the contract documents or shop drawings:

- (a) Details of reinforcement, inserts and lifting devices required to resist temporary loads from handling, storage, transportation, and erection;
- (b) Required concrete strength at stated ages or stages of construction.

6.10.3 Distribution of Forces in Members

6.10.3.1 Distribution of forces that are perpendicular to the plane of members shall be established by analysis or by test.

6.10.3.2 Where the system behavior requires in-plane forces to be transferred between the members of a precast floor or wall system, Sections 6.10.3.2.1 and 6.10.3.2.2 shall apply.

6.10.3.2.1 In-plane force paths shall be continuous through both connections and members.

6.10.3.2.2 Where tension forces occur, a continuous path of steel or steel reinforcement shall be provided.

6.10.4 Member Design

6.10.4.1 In one-way precast floor and roof slabs and in one-way precast, prestressed wall panels, all not wider than 3.7 m, and where members are not mechanically connected to cause restraint in the transverse direction, the shrinkage and temperature reinforcement requirements of Sec. 8.1.11 in the direction normal to the flexural reinforcement shall be permitted to be waived. This waiver shall not apply to members that require reinforcement to resist transverse flexural stresses.

6.10.4.2 For precast, non prestressed walls the reinforcement shall be designed in accordance with the provisions of Sec 6.3 or Sec 6.6, except that the area of horizontal and vertical reinforcement each shall be not less than $0.001A_g$, where A_g is the gross cross-sectional area of the wall panel. Spacing of reinforcement shall not exceed 5 times the wall thickness nor 750 mm for interior walls nor 450 mm for exterior walls.

6.10.5 Structural Integrity

6.10.5.1 Except where the provisions of Sec 6.10.5.2 govern, the minimum provisions of Sec 6.10.5.1.1 to 6.10.5.1.4 for structural integrity shall apply to all precast concrete structures.

6.10.5.1.1 Longitudinal and transverse ties required by Sec 8.1.12.3 shall connect members to a lateral load-resisting system.

6.10.5.1.2 Where precast elements form floor or roof diaphragms, the connections between diaphragm and those members being laterally supported shall have a nominal tensile strength capable of resisting not less than 4.4 kN per linear m.

6.10.5.1.3 Vertical tension tie requirements of Sec 8.1.12.3 shall apply to all vertical structural members, except cladding, and shall be achieved by providing connections at horizontal joints in accordance with (a) through (c):

- (a) Precast columns shall have a nominal strength in tension not less than $1.4A_g$, in N. For columns with a larger cross section than required by consideration of loading, a reduced effective area A_g (in mm^2), based on cross-section required but not less than one-half the total area, shall be permitted;
- (b) Precast wall panels shall have a minimum of two ties per panel, with a nominal tensile strength not less than 44 kN per tie;
- (c) When design forces result in no tension at the base, the ties required by Sec 6.10.5.1.3(b) shall be permitted to be anchored into an appropriately reinforced concrete floor slab-on-ground.

6.10.5.1.4 Connection details that rely solely on friction caused by gravity loads shall not be used.

6.10.5.2 For precast concrete bearing wall structures three or more stories in height, the minimum provisions of Sections 6.10.5.2.1 to 6.10.5.2.5 shall apply (Figure 6.6.29).

6.10.5.2.1 Longitudinal and transverse ties shall be provided in floor and roof systems to provide a nominal strength of 22 kN per meter of width or length. Ties shall be provided over interior wall supports and between members and exterior walls. Ties shall be positioned in or within 600 mm of the plane of floor or roof system.

6.10.5.2.2 Longitudinal ties parallel to floor or roof slab spans shall be spaced not more than 3 m on centers. Provisions shall be made to transfer forces around openings.

6.10.5.2.3 Transverse ties perpendicular to floor or roof slab spans shall be spaced not greater than the bearing wall spacing.

6.10.5.2.4 Ties around the perimeter of each floor and roof, within 1.2 m of the edge, shall provide a nominal strength in tension not less than 71 kN.

6.10.5.2.5 Vertical tension ties shall be provided in all walls and shall be continuous over the height of the building. They shall provide a nominal tensile strength not less than 44 kN per horizontal meter of wall. Not less than two ties shall be provided for each precast panel.

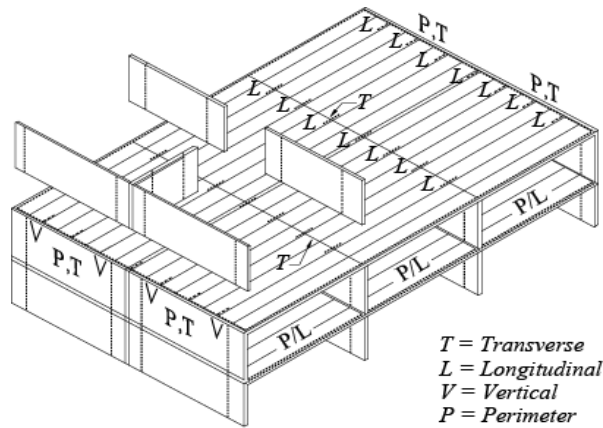


Figure 6.6.29 Typical arrangement of tensile ties in large panel structures.

6.10.6 Connection and Bearing Design

6.10.6.1 Forces shall be permitted to be transferred between members by grouted joints, shear keys, mechanical connectors, reinforcing steel connections, reinforced topping, or a combination of these means.

6.10.6.1.1 The adequacy of connections to transfer forces between members shall be determined by analysis or by test. Where shear is the primary result of imposed loading, it shall be permitted to use the provisions of Sec 6.4.5 as applicable.

6.10.6.1.2 When designing a connection using materials with different structural properties, their relative stiffnesses, strengths, and ductilities shall be considered.

6.10.6.2 Bearing for precast floor and roof members on simple supports shall satisfy Sections 6.10.6.2.1 and 6.10.6.2.2.

6.10.6.2.1 The allowable bearing stress at the contact surface between supported and supporting members and between any intermediate bearing elements shall not exceed the bearing strength for either surface or the bearing element, or both. Concrete bearing strength shall be as given in Sec 6.3.14.

6.10.6.2.2 Unless shown by test or analysis that performance will not be impaired, (a) and (b) shall be met (Figure 6.6.30):

- (a) Each member and its supporting system shall have design dimensions selected so that, after consideration of tolerances, the distance from the edge of the support to the end of the precast member in the direction of the span is at least $l_n/180$, but not less than:

For solid or hollow-core slabs	50 mm
For beams or stemmed members	75 mm

- (b) Bearing pads at unarmored edges shall be set back a minimum of 13 mm from the face of the support, or at least the chamfer dimension at chamfered edges.

6.10.6.2.3 The requirements of Sec 8.2.8.1 shall not apply to the positive bending moment reinforcement for statically determinate precast members, but at least one-third of such reinforcement shall extend to the center of the bearing length, taking into account permitted tolerances in Sections 8.1.5.2c and 6.10.2.3.

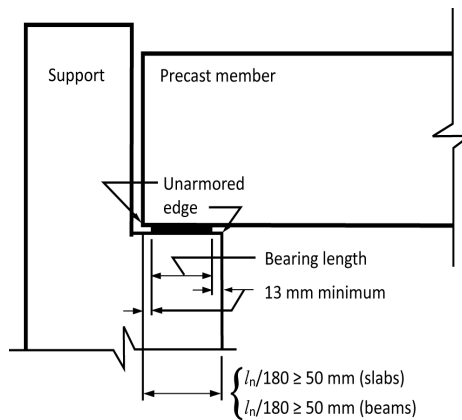


Figure 6.6.30 Bearing length on support

6.10.7 Items Embedded after Concrete Placement

6.10.7.1 When approved by the designer, embedded items (such as dowels or inserts) that either protrude from the concrete or remain exposed for inspection shall be permitted to be embedded while the concrete is in a plastic state provided that Sections 6.10.7.1.1, 6.10.7.1.2, and 6.10.7.1.3 are met.

6.10.7.1.1 Embedded items are not required to be hooked or tied to reinforcement within the concrete.

6.10.7.1.2 Embedded items are maintained in the correct position while the concrete remains plastic.

6.10.7.1.3 The concrete is properly consolidated around the embedded item.

6.10.8 Marking and Identification

6.10.8.1 Each precast member shall be marked to indicate its location and orientation in the structure and date of manufacture.

6.10.8.2 Identification marks shall correspond to placing drawings.

6.10.9 Handling

6.10.9.1 Member design shall consider forces and distortions during curing, stripping, storage, transportation, and erection so that precast members are not overstressed or otherwise damaged.

6.10.9.2 During erection, precast members and structures shall be adequately supported and braced to ensure proper alignment and structural integrity until permanent connections are completed.

6.10.10 Evaluation of Strength of Precast Construction

6.10.10.1 A precast element to be made composite with cast-in-place concrete shall be permitted to be tested in flexure as a precast element alone in accordance with Sections 6.10.10.1.1 and 6.10.10.1.2.

6.10.10.1.1 Test loads shall be applied only when calculations indicate the isolated precast element will not be critical in compression or buckling.

6.10.10.1.2 The test load shall be that load which, when applied to the precast member alone, induces the same total force in the tension reinforcement as would be induced by loading the composite member with the test load required by Sec 6.11.3.2.

6.10.10.2 The provisions of Sec 6.11.5 shall be the basis for acceptance or rejection of the precast element.

6.11 Evaluation of Strength of Existing Structures

6.11.1 Strength Evaluation - General

6.11.1.1 If there is doubt that a part or all of a structure meets the safety requirements of this Code, a strength evaluation shall be carried out as required by the Engineer.

6.11.1.2 If the effect of the strength deficiency is well understood and if it is feasible to measure the dimensions and material properties required for analysis, analytical evaluations of strength based on those measurements shall suffice. Required data shall be determined in accordance with Sec 6.11.2.

6.11.1.3 If the effect of the strength deficiency is not well understood or if it is not feasible to establish the required dimensions and material properties by measurement, a load test shall be required if the structure is to remain in service.

6.11.1.4 If the doubt about safety of a part or all of a structure involves deterioration, and if the observed response during the load test satisfies the acceptance criteria, the structure or part of the structure shall be permitted to remain in service for a specified time period. If deemed necessary by the Engineer, periodic reevaluations shall be conducted.

6.11.2 Determination of Material Properties and Required Dimensions

6.11.2.1 Dimensions of the structural elements shall be established at critical sections.

6.11.2.2 Locations and sizes of the reinforcing bars, welded wire reinforcement, or tendons shall be determined by measurement. It shall be permitted to base reinforcement locations on available drawings if spot checks are made confirming the information on the drawings.

6.11.2.3 If required, concrete strength shall be based on results of cylinder tests from the original construction or tests of cores removed from the part of the structure where the strength is in question. For strength evaluation of an existing structure, cylinder or core test data shall be used to estimate an equivalent f'_c . The method for obtaining and testing cores shall be in accordance with ASTM C42M.

6.11.2.4 If required, reinforcement or prestressing steel strength shall be based on tensile tests of representative samples of the material in the structure in question.

6.11.2.5 If the required dimensions and material properties are determined through measurements and testing, and if calculations can be made in accordance with Sec 6.11.1.2, it shall be permitted to increase ϕ from those specified in 6.2.3, but ϕ shall not be more than:

Tension-controlled sections, as defined in 6.3.3.4	1.0
Compression-controlled sections, as defined in Sec 6.3.3.3:	
Members with spiral reinforcement conforming to Sec 6.3.9.3	0.9
Other reinforced members	0.8
Shear and/or torsion	0.8
Bearing on concrete	0.8

6.11.3 Load Test Procedure

6.11.3.1 Load arrangement

The number and arrangement of spans or panels loaded shall be selected to maximize the deflection and stresses in the critical regions of the structural elements of which strength is in doubt. More than one test load arrangement shall be used if a single arrangement will not simultaneously result in maximum values of the effects (such as deflection, rotation, or stress) necessary to demonstrate the adequacy of the structure.

6.11.3.2 Load intensity

The total test load (including dead load already in place) shall not be less than the larger of (a), (b), and (c):

(a) $1.15D + 1.5L + 0.4(L_r \text{ or } P)$

(b) $1.15D + 0.9L + 1.5(L_r \text{ or } P)$

(c) $1.3D$

The load factor on the live load L in (b) shall be permitted to be reduced to 0.45 except for garages, areas occupied as places of public assembly, and all areas where, L is greater than 4.8 kN/m². It shall be permitted to reduce L in accordance with the provisions of this Code.

6.11.3.3 A load test shall not be made until that portion of the structure to be subjected to load is at least 56 days old. If the owner of the structure, the contractor, and all involved parties agree, it shall be permitted to make the test at an earlier age.

6.11.4 Loading Criteria

6.11.4.1 The initial value for all applicable response measurements (such as deflection, rotation, strain, slip, crack widths) shall be obtained not more than 1 hour before application of the first load increment. Measurements shall be made at locations where maximum response is expected. Additional measurements shall be made if required.

6.11.4.2 Test load shall be applied in not less than four approximately equal increments.

6.11.4.3 Uniform test load shall be applied in a manner to ensure uniform distribution of the load transmitted to the structure or portion of the structure being tested. Arching of the applied load shall be avoided.

6.11.4.4 A set of response measurements shall be made after each load increment is applied and after the total load has been applied on the structure for at least 24 hours.

6.11.4.5 Total test load shall be removed immediately after all response measurements defined in Sec 6.11.4.4 are made.

6.11.4.6 A set of final response measurements shall be made 24 hours after the test load is removed.

6.11.5 Acceptance Criteria

6.11.5.1 The portion of the structure tested shall show no evidence of failure. Spalling and crushing of compressed concrete shall be considered an indication of failure.

6.11.5.2 Measured deflections shall satisfy either Eq. (6.6.101) or (6.6.102):

$$\Delta_1 \leq \frac{l_t^2}{20,000h} \quad (6.6.101)$$

$$\Delta_r \leq \frac{\Delta_1}{4} \quad (6.6.102)$$

If the measured maximum and residual deflections, Δ_1 and Δ_r , do not satisfy Eq. (6.6.101) or (6.6.102), it shall be permitted to repeat the load test.

The repeat test shall be conducted not earlier than 72 hours after removal of the first test load. The portion of the structure tested in the repeat test shall be considered acceptable if deflection recovery Δ_r satisfies the condition:

$$\Delta_r \leq \frac{\Delta_2}{5} \quad (6.6.103)$$

Where, Δ_2 is the maximum deflection measured during the second test relative to the position of the structure at the beginning of the second test.

6.11.5.3 Structural members tested shall not have cracks indicating the imminence of shear failure.

6.11.5.4 In regions of structural members without transverse reinforcement, appearance of structural cracks inclined to the longitudinal axis and having a horizontal projection longer than the depth of the member at midpoint of the crack shall be evaluated.

6.11.5.5 In regions of anchorage and lap splices, the appearance along the line of reinforcement of a series of short inclined cracks or horizontal cracks shall be evaluated.

6.11.6 Provision for Lower Load Rating

If the structure under investigation does not satisfy conditions or criteria of Sec 6.11.1.2, Sec 6.11.5.2, or Sec 6.11.5.3, the structure shall be permitted for use at a lower load rating based on the results of the load test or analysis, if approved by the Engineer.

6.11.7 Safety

6.11.7.1 Load tests shall be conducted in such a way as to provide for safety of life and structure during test.

6.11.7.2 Safety measures shall not interfere with load test procedures or affect results.

6.12 Composite Concrete Flexural Members

6.12.1 Scope

6.12.1.1 Provisions of Sec 6.12 shall apply for design of composite concrete flexural members defined as precast concrete, cast-in-place concrete elements, or both, constructed in separate placements but so interconnected that all elements respond to loads as a unit.

6.12.1.2 All provisions of the Code shall apply to composite concrete flexural members, except as specifically modified in Sec 6.12.

6.12.2 General

6.12.2.1 The use of an entire composite member or portions thereof for resisting shear and moment shall be permitted.

6.12.2.2 Individual elements shall be investigated for all critical stages of loading.

6.12.2.3 If the specified strength, unit weight, or other properties of the various elements are different, properties of the individual elements or the most critical values shall be used in design.

6.12.2.4 In strength computations of composite members, no distinction shall be made between shored and unshored members.

6.12.2.5 All elements shall be designed to support all loads introduced prior to full development of design strength of composite members.

6.12.2.6 Reinforcement shall be provided as required to minimize cracking and to prevent separation of individual elements of composite members.

6.12.2.7 Composite members shall meet requirements for control of deflections in accordance with Sec 6.2.5.4.

6.12.3 Shoring

When used, shoring shall not be removed until supported elements have developed design properties required to support all loads and limit deflections and cracking at time of shoring removal.

6.12.4 Vertical Shear Strength

6.12.4.1 Where an entire composite member is assumed to resist vertical shear, design shall be in accordance with requirements of Sec 6.4 as for a monolithically cast member of the same cross-sectional shape.

6.12.4.2 Shear reinforcement shall be fully anchored into interconnected elements in accordance with Sec 8.2.10.

6.12.4.3 Extended and anchored shear reinforcement shall be permitted to be included as ties for horizontal shear.

6.12.5 Horizontal Shear Strength

6.12.5.1 In a composite member, full transfer of horizontal shear forces shall be ensured at contact surfaces of interconnected elements.

6.12.5.2 For the provisions of Sec 6.12.5, d shall be taken as the distance from extreme compression fiber for entire composite section to centroid of longitudinal tension reinforcement, if any.

6.12.5.3 Unless calculated in accordance with Sec 6.12.5.4, design of cross sections subject to horizontal shear shall be based on

$$V_u \leq \phi V_{nh} \quad (6.6.104)$$

Where, V_{nh} is nominal horizontal shear strength in accordance with Sections 6.12.5.3.1 to 6.12.5.3.4.

6.12.5.3.1 Where contact surfaces are clean, free of laitance, and intentionally roughened, V_{nh} shall not be taken greater than $0.55b_v d$.

6.12.5.3.2 Where minimum ties are provided in accordance with Sec 6.12.6, and contact surfaces are clean and free of laitance, but not intentionally roughened, V_{nh} shall not be taken greater than $0.55b_v d$.

6.12.5.3.3 Where ties are provided in accordance with Sec 6.12.6, and contact surfaces are clean, free of laitance, and intentionally roughened to a full amplitude of approximately 6 mm, V_{nh} shall be taken equal to, $(1.8 + 0.6\rho_v f_v)\lambda b_v d$, but not greater than $3.5b_v d$. Values for λ in Sec 6.4.5.4.3 shall apply and ρ_v is $A_v/(b_v s)$.

6.12.5.3.4 Where V_u at section considered exceeds $\phi(3.5b_v d)$, design for horizontal shear shall be in accordance with Sec 6.4.5.4.

6.12.5.4 As an alternative to Sec 6.12.5.3, horizontal shear shall be permitted to be determined by computing the actual change in compressive or tensile force in any segment, and provisions shall be made to transfer that force as horizontal shear to the supporting element. The factored horizontal shear force V_u shall not exceed horizontal shear strength ϕV_{nh} as given in Sections 6.12.5.3.1 to 6.12.5.3.4, where area of contact surface shall be substituted for $b_v d$.

6.12.5.4.1 Where ties provided to resist horizontal shear are designed to satisfy Sec 6.12.5.4, the tie area to tie spacing ratio along the member shall approximately reflect the distribution of shear forces in the member.

6.12.5.5 Where tension exists across any contact surface between interconnected elements, shear transfer by contact shall be permitted only when minimum ties are provided in accordance with Sec 6.12.6.

6.12.6 Ties for Horizontal Shear

6.12.6.1 Where ties are provided to transfer horizontal shear, tie area shall not be less than that required by Sec 6.4.3.5.3, and tie spacing shall not exceed four times the least dimension of supported element, nor exceed 600 mm.

6.12.6.2 Ties for horizontal shear shall consist of single bars or wire, multiple leg stirrups, or vertical legs of welded wire reinforcement.

6.12.6.3 All ties shall be fully anchored into interconnected elements in accordance with Sec 8.2.10.

6.13 List of Related Appendices

Appendix I Strut-and-Tie Models

Appendix J Working Stress Design Method for Reinforced Concrete Structures

Appendix K Anchoring to Concrete

Appendix L Information on Steel Reinforcement

Appendix M Special Types of Stairs

PART VI
Chapter 7
Masonry Structures

7.1 Introduction

7.1.1 Scope

This Chapter of the Code covers the design, construction and quality control of masonry structures.

7.1.2 Definitions

For the purpose of this Chapter, the following definitions shall be applicable.

ACTUAL DIMENSIONS	The measured dimensions of a designated item; such as a designated masonry unit or wall used in the structures. The actual dimension shall not vary from the specified dimension by more than the amount allowed in the appropriate standard mentioned in Sec 2.2.4 Chapter 2 Part 5.
BED BLOCK	A block bedded on a wall, column or pier to disperse a concentrated load on a masonry element.
BED JOINT	A horizontal mortar joint upon which masonry units are placed.
BOND	Arrangement of masonry units in successive courses to tie the masonry together both longitudinally and transversely; the arrangement is usually worked out to ensure that no vertical joint of one course is exactly over the one in the next course above or below it and there is maximum possible amount of lap.
BOND BEAM	A horizontal grouted element within masonry in which reinforcement is embedded.
BUTTRESS	A pier of masonry built as an integral part of wall and projecting from either or both surfaces, decreasing in cross-sectional area from base to top and conforming to the requirement of Sec 4.3.3(c) (ii).
CAVITY WALL	A wall comprising two limbs each built-up as single or multi-wythe units and separated by a 50-115 mm wide cavity. The limbs are tied together by metal ties or bonding units for structural integrity.

CELL	A void space having a gross cross-sectional area greater than 1000 mm ² .
COLLAR JOINT	The vertical, longitudinal, mortar or grouted joints.
COLUMN	An isolated vertical load bearing member the width of which does not exceed three times the thickness.
CROSS JOINT	A vertical joint normal to the face of the wall.
CROSS-SECTIONAL AREA OF MASONRY UNIT	Net cross-sectional area of masonry unit is the gross cross-sectional area minus the area of cellular space.
CURTAIN WALL	A non-load bearing self-supporting wall subject to transverse lateral loads, and laterally supported by vertical or horizontal structural member where necessary.
FACED WALL	A wall in which facing and backing of two different materials are bonded together to ensure common action under load.
GROUT	A mixture of cementitious materials and aggregate to which water is added such that the mixture will flow without segregation of the constituents.
GROUTED HOLLOW-UNIT MASONRY	That form of grouted masonry construction in which certain designated cells of hollow units are continuously filled with grout.
GROUTED MULTI-WYTHE MASONRY	That form of grouted masonry construction in which the space between the wythes is solidly or periodically filled with grout.
HOLLOW UNIT	A masonry unit of which net cross-sectional area in any plane parallel to the bearing surface is less than 75 percent of its gross cross-sectional area measured in the same plane.
JAMB	Side of an opening in wall.
HEAD JOINT	The mortar joint having a vertical transverse plane.
LATERAL SUPPORT	A support which enables a masonry element to resist lateral load and/or restrains lateral deflection of a masonry element at the point of support.
LIMB	Inner or outer portion of a cavity wall.
LOAD BEARING WALL	A wall designed to carry an imposed vertical load in addition to its own weight, together with any lateral load.

MASONRY	An assemblage of masonry units properly bonded together with mortar.
MASONRY UNIT	Individual units, such as brick, tile, stone or concrete block, which are bonded together with mortar to form a masonry element such as walls, columns, piers, buttress, etc.
NOMINAL DIMENSIONS	Specified dimensions plus the thickness of the joint with which the unit is laid.
PANEL WALL	An exterior non-load bearing wall in framed structure, supported at each storey but subject to lateral loads.
PARTITION WALL	An interior non-load bearing wall, one storey or part storey in height.
PIER	A projection from either or both sides of a wall forming an integral part of the wall and conforming to the requirement of Sec 7.4.3.3 of this Chapter.
PILASTER	A thickened section forming integral part of a wall placed at intervals along the wall, to increase the stiffness of the wall or to carry a vertical concentrated load. Thickness of a pier is the overall thickness including the thickness of the wall or, when bounded into a limb of cavity wall, the thickness obtained by treating that limb as an independent wall.
PRISM	An assemblage of masonry units bonded by mortar with or without grout used as a test specimen for determining properties of masonry.
REINFORCED MASONRY	The masonry construction, in which reinforcement acting in conjunction with the masonry is used to resist forces and is designed in accordance with Sec 7.6 of this Chapter.
SHEAR WALL	A load bearing wall designed to carry horizontal forces acting in its own plane with or without vertical imposed loads.
SOLID UNIT	A masonry unit whose net cross-sectional area in any plane parallel to the bearing surface is 75 percent or more of the gross cross-sectional area in the same plane.
SPECIFIED DIMENSIONS	The dimensions specified for the manufacture or construction of masonry, masonry units, joints or any other components of a structure. Unless otherwise stated, all calculations shall be made using or based on specified dimensions.

STACK BOND	A bond in bearing and nonbearing walls, except veneered walls, in which less than 75 percent of the units in any transverse vertical plane lap the ends of the units below a distance less than one-half the height of the unit, or less than one-fourth the length of the unit.
VENEERED WALL	A wall in which the facing is attached to the backing but not so bonded as to result in a common action under load.
WALL JOINT	A vertical joint parallel to the face of the wall.
WALL TIE	A metal fastener which connects wythes of masonry to each other or to other materials.
WYTHER	Portion of a wall which is one masonry unit in thickness.

7.1.3 Symbols and Notation

The following units shall be generally implicit in this Chapter for the corresponding quantities:

Lengths	m m
Areas	m m ²
Moment of inertia	m m ⁴
Force	N
Moment, torsion	N m m
Stress, strength	N/mm ²

A_b	=	Cross-sectional area of anchor bolt
A_e	=	Effective area of masonry
A_g	=	Gross area of wall
A_{mv}	=	Net area of masonry section bounded by wall thickness and length of section in the direction of shear force considered
A_p	=	Area of tension (pullout) cone of an embedded anchor bolt projected into the surface of masonry
A_s	=	Effective cross-sectional area of reinforcement in a flexural member
A_v	=	Area of steel required for shear reinforcement perpendicular to the longitudinal reinforcement

A'_s	=	Effective cross-sectional area of compression reinforcement in a flexural member
B_t	=	Allowable tension force on anchor bolt
B_v	=	Computed shear force on anchor bolt
C_d	=	Masonry shear strength coefficient
E_m	=	Modulus of elasticity of masonry
E_s	=	Modulus of elasticity of steel
F	=	Loads due to weight and pressure of fluids or related moments and forces
F_a	=	Allowable average axial compressive stress for centroidally applied axial load only
F_b	=	Allowable flexural compressive stress if members were carrying bending load only
F_{br}	=	Allowable bearing stress
F_s	=	Allowable stress in reinforcement
F_{sc}	=	Allowable compressive stress in column reinforcement
F_t	=	Allowable flexural tensile stress in masonry
F_v	=	Allowable shear stress in masonry
G	=	Shear modulus of masonry
H	=	Actual height between lateral supports
H'	=	Height of opening
I	=	Moment of inertia about the neutral axis of the cross-sectional area
I_g, I_{cr}	=	Gross, cracked moment of inertia of the wall cross-section
L	=	Actual length of wall
M	=	Design moment
M_c	=	Moment capacity of the compression steel in a flexural member about the centroid of the tensile force
M_{cr}	=	Cracking moment strength of the masonry wall
M_m	=	The moment of the compressive force in the masonry about the centroid of the tensile force in the reinforcement

M_n	=	Nominal moment strength of the masonry wall
M_s	=	The moment of the tensile force in the reinforcement about the centroid of the compressive force in the masonry
M_{ser}	=	Service moment at the mid-height of the panel, including P-Delta effects
M_u	=	Factored moment
P	=	Design axial load
P_a	=	Allowable centroidal axial load for reinforced masonry columns
P_b	=	Nominal balanced design axial strength
P_f	=	Load from tributary floor or roof area
P_o	=	Nominal axial load strength with bending
P_u	=	Factored axial load
P_{uf}	=	Factored load from tributary floor or roof loads
P_{uw}	=	Factored weight of the wall tributary to the section under consideration
P_w	=	Weight of the wall tributary to the section under consideration
S	=	Section modulus
V	=	Total design shear force
V_m	=	Nominal shear strength provided by masonry
V_n	=	Nominal shear strength
V_s	=	Nominal shear strength provided by shear reinforcement
a	=	Depth of equivalent rectangular stress block for strength design
b	=	Effective width of rectangular member or width of flange for T and I section
b_t	=	Computed tension force on anchor bolt
b_v	=	Allowable shear force on anchor bolt
b_w	=	Width of web in T and I member
c	=	Distance from the neutral axis to extreme fibre
d	=	Distance from the compression face of a flexural member to the centroid of longitudinal tensile reinforcement

d_b	=	Diameter of the reinforcing bar, diameter of bolt
e	=	Eccentricity of P_u
e_{mu}	=	Maximum usable compressive strain of masonry
f_a	=	Computed axial compressive stress due to design axial load
f_b	=	Computed flexural stress in the extreme fibre due to design bending load only
f_{md}	=	Computed compressive stress in masonry due to dead load only
f_r	=	Modulus of rupture
f_s	=	Computed stress in reinforcement due to design load
f_y	=	Tensile yield stress of reinforcement
f_v	=	Computed shear stress due to design load
f'_m	=	Specified compressive strength of masonry at the age of 28 days
h	=	Height of wall between points of support
h'	=	Effective height of a wall or column
j	=	Ratio or distance between centroid of flexural compressive force and centroid of tensile forces to depth, d
k	=	Ratio of depth of the compression zone in flexural member to depth, d ; stiffening coefficient
l	=	Length of a wall or segment
l_b	=	Embedment depth of anchor bolt
l_{be}	=	Anchor bolt edge distance, the least length measured from the edge of masonry to the surface of the anchor bolt
l_d	=	Required development length of reinforcement
n	=	Modular ratio = E_s/E_m
r_b	=	Ratio of the area of bars cut off to the total area of bars at the section
s	=	Spacing of stirrups or bent bars in a direction parallel to that of the main reinforcement
t	=	Effective thickness of a wythe, wall or column

u	=	Bond stress per unit of surface area of bar
Δ_u	=	Horizontal deflection at mid-height under factored load; P-Delta effects shall be included in deflection calculation
Σ_o	=	Sum of the perimeters of all the longitudinal reinforcement
ρ	=	Steel ratio = A_s/bd
ρ_n	=	Ratio of distributed shear reinforcement on a plane perpendicular to the plane of A_{mv}
ϕ	=	Strength reduction factor.

7.2 Materials

7.2.1 General

All materials used in masonry construction shall conform to the requirements specified in Part 5 of this Code. If no requirements are specified for a material, quality shall be based on generally accepted good practice, subject to the approval of the building official.

7.2.2 Masonry Units

The following types of masonry units which conform to the standards mentioned in Sec 2.2.4 of Part 5 may be used in masonry construction:

- (a) Common building clay bricks
- (b) Burnt clay hollow bricks
- (c) Burnt clay facing bricks
- (d) Hollow concrete blocks

Other types of masonry units conforming to Sec 2.2.4 of Part 5 may also be used.

7.2.3 Mortar and Grout

Mortar and grout for masonry construction shall conform to the requirements specified in Part 5 of this Code. Mix proportions and compressive strength of some commonly used mortars are given in Table 6.7.1.

7.3 Allowable Stresses

7.3.1 General

Stresses in masonry shall not exceed the values given in this Section. All allowable stresses for working stress design may be increased one third when considering wind or earthquake forces either acting alone or combined with vertical loads. No increase shall be allowed for vertical loads acting alone.

7.3.2 Specified Compressive Strength of Masonry, f'_m

The allowable stresses for masonry construction shall be based on the value of f'_m as determined by Sec 7.3.3 below.

Table 6.7.1: Mix Proportion and Strength of Commonly used Mortars

Grade of Mortar	Mix Proportion by Volume ^{1,2}		Minimum Compressive Strength at 28 days, N/mm ²
	Cement	Sand	
M1		3	10
M2		4	7.5
M3	1	5	5
M4		6	3
M5		7	2
M6		8	1

1 Sand and cement shall be measured in loose volume and sand shall be well graded with a minimum F.M. of 1.20

2 Lime to a maximum of one fourth (1/4) part by volume of cement may be used to increase workability.

7.3.3 Compliance with f'_m

Compliance with the requirements for the specified compressive strength of masonry, f'_m shall be in accordance with the following:

7.3.3.1 Masonry Prism Testing: The compressive strength of masonry based on tests at 28 days in accordance with "Standard Test Method for Compressive Strength of Masonry Prisms", (ASTM E447) for each set of prisms shall equal or exceed f'_m . Verification by masonry prism testing shall meet the following :

- Testing Prior to Construction: A set of five masonry prisms shall be built and tested in accordance with ASTM E447 prior to the start of construction. Materials used for prisms shall be same as used in the project. Prisms shall be constructed under the observation of the engineer or an approved agency and tested by an approved agency.

- (b) Testing During Construction: When full allowable stresses are used in design, a set of three prisms shall be built and tested during construction in accordance with (ASTM E447) for each 500 square meters of wall area, but not less than one set of three masonry prisms for any project. No testing during construction shall be required when 50% of the allowable stresses are used in design.

7.3.4 Quality Control

Quality control shall include, but not be limited to assure that:

- (a) Masonry units, reinforcement, cement, lime, aggregate and all other materials meet the requirements of the applicable standard of quality and that they are properly stored and prepared for use.
- (b) Mortar and grout are properly mixed using specified proportions of ingredients. The method of measuring materials for mortar and grout shall be such that proportions of materials are controlled.
- (c) Construction details, procedures and workmanship are in accordance with the plans and specification.
- (d) Placement, splices and bar diameters are in accordance with the provisions of this Chapter and the plans and specifications.

7.3.5 Allowable Stresses in Masonry

When the quality control provisions specified in Sec 7.3.4 above do not include requirements for special inspection, the allowable design stresses in this Section shall be reduced by 50 percent.

- (a) Axial Compressive Stress

- (i) Unreinforced masonry walls, columns and reinforced masonry wall

$$F_a = \frac{f'_m}{5} \left[1 - \left(\frac{h'}{42t} \right)^3 \right] \quad (6.7.1)$$

- (ii) Reinforced masonry columns

$$F_a = \left(\frac{f'_m}{5} + \frac{A_s}{1.5A_g} F_{sc} \right) \left[1 - \left(\frac{h'}{42t} \right)^3 \right] \quad (6.7.2)$$

- (b) Compressive Stress in Flexural

$$F_b = 0.33f'_m \leq 10 \text{ N/mm}^2 \quad (6.7.3)$$

(c) Tensile Stress of Walls in Flexure

The allowable tensile stress for walls in flexure of masonry structures without tensile reinforcement using mortar Type M₁ or M₂ shall not exceed the values specified in Tables 6.7.2 and 6.7.3. For Types M₃ and M₄ mortar, the values shall be reduced by 25 percent.

No tension is allowed across head joints in stack bond masonry. Values for tension normal to head joints are for running bond. These values shall not be used for horizontal flexural members such as beams, girders or lintels.

Table 6.7.2: Flexural Tension, Ft

Masonry	Normal to Bed Joints N/mm ²	Normal to Head Joints N/mm ²
Solid Units	0.20	0.40
Hollow Units	0.12	0.25

Table 6.7.3: Tension Normal to Head Joints, Ft

Masonry	Clay Units N/mm ²	Concrete Units N/mm ²
Solid Units	0.35	0.40
Hollow Units	0.22	0.25

(d) Reinforcing Bond Stress, u

Plain Bars: 0.30 N/mm²

Deformed Bars: 1.0 N/mm²

(e) Shear Stress for Flexural Members, F_v

(i) When no shear reinforcement is used

$$F_v = 0.083\sqrt{f'_m} \leq 0.25 \text{ N/mm}^2 \quad (6.7.4)$$

(ii) When shear reinforcement is designed to take entire shear force

$$F_v = 0.25\sqrt{f'_m} \leq 0.75 \text{ N/mm}^2 \quad (6.7.5)$$

(f) Shear Stress for Shear Walls, F_v

(i) Unreinforced masonry

For clay units:

$$F_v = 0.025\sqrt{f'_m} \leq 0.40 \text{ N/mm}^2 \quad (6.7.6)$$

For concrete units:

$$M_1 \text{ or } M_2 \text{ Mortar: } 0.20 \text{ N/mm}^2$$

$$M_3 \text{ Mortar: } 0.12 \text{ N/mm}^2$$

(ii) The allowable shear stress for reinforced masonry shear walls shall be according to Table 6.7.4.

Table 6.7.4: Allowable Shear Stress for Reinforced Masonry Shear Walls, F_v

Masonry Wall	M/Vd	F_v N/mm ²	Maximum Allowable N/mm ²
Masonry taking all shear	< 1	$\frac{1}{36} \left(4 - \frac{M}{Vd} \right) \sqrt{f'_m}$	$\left(0.4 - 0.2 \frac{M}{Vd} \right)$
	≥ 1	$0.083 \sqrt{f'_m}$	0.17
Reinforcement taking all shear	< 1	$\frac{1}{24} \left(4 - \frac{M}{Vd} \right) \sqrt{f'_m}$	$\left(0.6 - 0.2 \frac{M}{Vd} \right)$
	≥ 1	$0.125 \sqrt{f'_m}$	0.37

7.3.6 Allowable Stresses in Reinforcement

(a) Tensile Stress

(i) Deformed bars,

$$F_s = 0.5f_y \leq 165 \text{ N/mm}^2 \quad (6.7.7)$$

(ii) Ties, anchors and plain bars,

$$F_s = 0.4f_y \leq 135 \text{ N/mm}^2 \quad (6.7.8)$$

(b) Compressive Stress

(i) Deformed bars in columns and shear walls,

$$F_{sc} = 0.4f_y \leq 165 \text{ N/mm}^2 \quad (6.7.9)$$

(ii) Deformed bars in flexural members

$$F_{sc} = 0.5f_y \leq 165 \text{ N/mm}^2 \quad (6.7.10)$$

7.3.7 Combined Compressive Stress

Members subject to combined axial and flexural stresses shall be designed in accordance with accepted principles of mechanics or in accordance with the following formula:

$$\frac{f_a}{F_a} + \frac{f_b}{F_b} \leq 1 \quad (6.7.11)$$

7.3.8 Modulus of Elasticity

The modulus of elasticity of masonry shall be determined by the secant method. The slope of the line connecting the points $0.05f'_m$ and $0.33f'_m$ on the stress-strain curve shall be taken as the modulus of elasticity of masonry. If required, actual values shall be established by tests. These values are not to be reduced by 50 per cent as specified in Sec 7.3.5(a).

- (a) Modulus of Elasticity for Masonry

$$E_m = 750f'_m \leq 15,000 \text{ N/mm}^2 \quad (6.7.12)$$

- (b) Modulus of Elasticity for Steel

$$E_s = 2,00,000 \text{ N/mm}^2 \quad (6.7.13)$$

- (c) Shear Modulus of Masonry

$$G = 0.4E_m \text{ N/mm}^2 \quad (6.7.14)$$

7.3.9 Shear and Tension on Embedded Anchor Bolts

7.3.9.1 Allowable loads and placement requirements for anchor bolts shall be in accordance with the following:

- Bent bar anchor bolts shall have a hook with a 90° bend with an inside diameter of $3d_b$ plus an extension of $1.5d_b$ at the free end.
- Headed anchor bolts shall have a standard bolt head.
- Plate anchor bolts shall have a plate welded to the shank to provide anchorage equivalent to headed anchor bolts.

7.3.9.2 The effective embedment length, l_b for bent bar anchors shall be the length of embedment measured perpendicular from the surface of the masonry to the bearing surface of the bent end minus one anchor bolt diameter. For plate or headed anchor bolts l_b shall be the length of embedment measured perpendicular from the surface of the masonry to the bearing surface of the plate or head of the anchorage. All bolts shall be grouted in place with at least 25 mm of grout between the bolt and the masonry except that 6 mm diameter bolts may be placed in bed joints which are at least twice as thick as the diameter of the bolt.

7.3.9.3 Allowable shear force

Allowable loads in shear shall be according to Table 6.7.5 or lesser of the value obtained from the following formulae:

$$B_v = 1070(f'_m A_b)^{1/4} \quad (6.7.15)$$

$$B_v = 0.12A_b f_y \quad (6.7.16)$$

When the distance l be is less than $12d_b$, the value of B_v in Eq. 6.7.15 shall be reduced to zero at a distance l_{be} equal to 40 mm. Where adjacent anchors are spaced closer than $8d_b$, the allowable shear of the adjacent anchors determined by Eq. 6.7.15 shall be reduced by interpolation to 0.75 times the allowable shear value at a centre to centre spacing of $4d_b$.

7.3.9.4 Allowable tension

Allowable tension shall be the lesser value selected from Table 6.7.6 and Table 6.7.7 or shall be determined from lesser of the values obtained from the following formulae:

$$B_t = 0.04A_p\sqrt{f'_m} \quad (6.7.17)$$

$$B_t = 0.2A_b f_y \quad (6.7.18)$$

The area A_p shall be the lesser of the area obtained from Equations 6.7.17 and 6.7.18 and where the projected areas of adjacent anchor bolts overlap, A_p of each anchor bolt shall be reduced by 50 percent of the overlapping area.

$$A_p = \pi l_b^2 \quad (6.7.19)$$

$$A_p = \pi l_{be}^2 \quad (6.7.20)$$

Table 6.7.5: Allowable Shear, B_v for Embedded Anchor Bolts for Masonry, kN*

Bent Bar Anchor Bolt Diameter, mm							
f'_m N/mm ²	10	12	16	20	22	25	28
10	2.0	3.7	5.9	7.9	8.5	9.1	9.6
12	2.0	3.7	5.9	8.2	8.3	9.5	10.1
13	2.0	3.7	5.9	8.5	9.2	9.8	10.4
17	2.0	3.7	5.9	8.5	9.7	10.3	11.0
20	2.0	3.7	5.9	8.5	10.1	10.8	11.5
27	2.0	3.7	5.9	8.5	10.9	11.6	12.3

* Values are for bolts of at least ASTM A307 quality. Bolts shall be those specified in Sec 4.3.9.1.

Table 6.7.6: Allowable Tension, B_t for Embedded Anchor Bolts for Masonry, kN^{1,2}

f'_m N/mm ²	Embedment Length l_b , or Edge Distance, l_{be} mm						
	50	75	100	125	150	200	250
10	1.0	2.4	4.3	6.7	9.7	17.3	27.0
12	1.2	2.6	4.7	7.4	10.6	18.9	29.6
13	1.2	2.8	5.0	7.8	11.2	20.0	31.2
17	1.3	3.1	5.6	8.7	12.6	22.4	35.0
20	1.5	3.4	6.7	9.5	13.8	24.5	38.2
27	1.7	3.9	7.0	11.0	15.9	28.3	44.1

- 1 The allowable tension values are based on compressive strength of masonry assemblages. Where yield strength of anchor bolt steel governs, the allowable tension is given in Table 6.7.7.
- 2 Values are for bolts of at least ASTM A307 quality. Bolts shall be those specified in Sec 7.3.9.1.

Table 6.7.7: Allowable Tension, B_t for Embedded Anchor Bolts for Masonry, kN¹

	Bent Bar Anchor Bolt Diameter, mm							
	6	10	12	16	20	22	25	28
1.5	3.5	6.2	9.8	14.1	19.2	25.1	31.8	

- 1 Values are for bolts of at least ASTM A307 quality. Bolts shall be those specified in Sec 7.3.9.

7.3.9.5 Combined shear and tension

Anchor bolts subjected to combined shear and tension shall be designed in accordance with the formula given below:

$$\frac{b_t}{B_t} + \frac{b_v}{B_v} \leq 1.00 \quad (6.7.21)$$

7.3.9.6 Minimum edge distance, l_{be}

The minimum value of l_{be} measured from the edge of the masonry parallel to the anchor bolt to the surface of the anchor bolt shall be 40 mm.

7.3.9.7 Minimum embedment depth, l_b

The minimum embedment depth l_b shall be $4d_b$ but not less than 50 mm.

7.3.9.8 Minimum spacing between bolts

The minimum centre to centre spacing between anchors shall be $4d_b$.

7.3.10 Load Test

For load test, the member shall be subject to a superimposed load equal to twice the design live load plus one-half of the dead load. This load shall be maintained for a period of 24 hours. If, during the test or upon removal of the load, the member shows evidence of failure, such changes or modifications as are necessary to make the structure adequate for the rated capacity shall be made; or where possible, a lower rating shall be established. A flexural member shall be considered to have passed the test if the maximum deflection at the end of the 24 hour period neither exceeds $0.005l$ nor $0.00025 l^2/t$ and the beam and slabs show a recovery of at least 75 percent of the observed deflection within 24 hours after removal of the load.

7.3.11 Reuse of Masonry Units

Masonry units may be reused when clean, unbroken and conforms to the requirements of Part 5. All structural properties of masonry of reclaimed units, especially adhesion bond, shall be determined by approved test. The allowable working stress shall not exceed 50 percent of that permitted for new masonry units of the same properties.

7.4 Basic Design Requirements

7.4.1 General

Masonry structures shall be designed according to the provisions of this Section. The required design strengths of masonry materials and any special requirements shall be specified in the plan submitted for approval.

7.4.2 Design Considerations

7.4.2.1 Masonry structures shall be designed based on working stress and linear stress-strain distribution. Requirements for working stress design of unreinforced and reinforced masonry structures are provided in Sections 4.5 and 4.6 respectively. In lieu of the working stress design method, slender walls and shear walls may be designed by the strength design method specified in Sec 7.7.

The structure shall be proportioned such that eccentricity of loading on the members is as small as possible. Eccentric loading shall preferably be avoided by providing:

- (a) adequate bearing of floor/roof on the walls
- (b) adequate stiffness in slabs, and
- (c) fixity at the supports.

7.4.2.2 Effective height

- (a) Wall: The effective height of a wall shall be taken as the clear height between the lateral supports at top and bottom in a direction normal to the axis considered. For members not supported at the top normal to the axis considered, the effective height is twice the height of the member above the support. Effective height less than the clear height may be used if justified.
- (b) Column: Effective height of the column shall be taken as actual height for the direction it is laterally supported and twice the actual height for the direction it is not laterally supported at the top normal to the axis considered.
- (c) Opening in Wall: When openings occur in a wall such that masonry between the openings is by definition a column, effective height of masonry between the openings shall be obtained as follows:
 - (i) When wall has full restraint at the top, effective height for the direction perpendicular to the plane of wall equals $0.75H$ plus $0.25H'$, where H is the distance between supports and H' is the height of the taller opening; and effective height for the direction parallel to the wall equals H .
 - (ii) When wall has partial restraint at the top and bottom, effective height for the direction perpendicular to the plane of wall equals H when height of neither opening exceeds $0.5H$ and it is equal to $2H$ when height of any opening exceeds $0.5H$; and effective height for the direction parallel to the plane of the wall equals $2H$.

7.4.2.3 Effective length

Effective length of a wall for different support conditions shall be as given in Table 6.7.8.

7.4.2.4 Effective thickness

The effective thickness of walls and columns for use in the calculation of slenderness ratio, shall be defined as follows:

- (a) Solid Walls: The effective thickness of solid walls, faced walls or grouted walls shall be the specified thickness of the wall.

- (b) Solid Walls with Raked Mortar Joints: The effective thickness of solid walls with raked mortar joints shall be the minimum thickness measured at the joint.
- (c) Cavity Walls: When both limbs of a cavity wall are axially loaded, each limb shall be considered independently and the effective thickness of each limb shall be determined as in (a) or (b) above. If one of the limbs is axially loaded, the effective thickness of the cavity wall shall be taken as the square root of the sum of the squares of the effective thicknesses of the limbs.
- (d) Walls Stiffened by Pilasters: When solid or cavity walls are stiffened by pilasters at intervals, the effective thickness to be used for the calculation of h'/t ratio shall be determined as follows:
- (i) Solid Walls: For stiffened solid walls the effective thickness shall be the specified thickness multiplied by the stiffening coefficient, k , values of which are given below:

l_p/w_p	Stiffening Coefficient, k^*		
	$t_p/t_w = 1$	$t_p/t_w = 2$	$t_p/t_w = 3$
6	1.0	1.4	2.0
8	1.0	1.3	1.7
10	1.0	1.2	1.4
15	1.0	1.1	1.2
20 or more	1.0	1.0	1.0

* Linear interpolation is permitted for obtaining intermediate values of k

Where, l_p = centre to centre spacing of pilasters
 t_p = thickness of pilaster including the wall
 t_w = specified thickness of main wall
 w_p = width of pilaster in the direction of wall

- (ii) Cavity Walls: When one or both limbs of a cavity wall are adequately bonded into pilasters at intervals, the effective thickness of each limb shall be determined separately as in (a), (b) or d above and the effective thickness of the stiffened cavity wall shall be determined in accordance with (c) above.
- Where slenderness ratio of the wall is based on the effective length, the effective thickness shall be the same as that without pilasters.
- (e) Columns: The effective thickness for rectangular columns in the direction considered is the actual thickness provided in that direction. The effective thickness for nonrectangular columns is the thickness of a square column with the same moment of inertia about its axis as that about the axis considered in the actual column.

Table 6.7.8: Effective Length of Walls

Support Condition	Effective Length
Where a wall is continuous and is supported by cross wall and there is no opening within a distance of $H/8$ from the face of cross wall. OR, Where a wall is continuous and is supported by pier/buttresses conforming to Sec 7.4.3.3 (c).	0.8L
Where a wall is supported by cross wall at one end and continuous with cross wall at other end. OR, Where a wall is supported by pier/buttresses at one end and continuous with pier/buttresses at other end conforming to Sec 7.4.3.3 (c).	0.9L
Where a wall is supported at each end by cross wall. OR, Where a wall is supported at each end by pier/buttresses conforming to Sec 7.4.3.3 (c).	1.0L
Where a wall is free at one end and continuous with a cross wall at the other end. OR, Where a wall is free at one end and continuous with a pier/buttresses at the other end conforming to Sec 7.4.3.3 (c).	1.5L
Where a wall is free at one end and supported at the other end by a cross wall. OR, Where a wall is free at one end and supported at the other end by a pier/buttresses conforming to Sec 7.4.3.3 (c).	2.0L

7.4.2.5 Slenderness ratio

- (a) Walls: For a wall, slenderness ratio shall be the ratio of effective height to effective thickness or effective length to effective thickness whichever less is. In case of a load bearing wall, slenderness ratio shall not exceed 20.
- (b) Column: For a column, slenderness ratio shall be taken to be the greater of the ratio of effective heights to the respective effective thickness in the two principal directions. Slenderness ratio for a load bearing column shall not exceed 12.

7.4.2.6 Effective area

The effective cross-sectional area shall be based on the minimum bedded area of the hollow units, or the gross area of solid units plus any grouted area. If hollow units are used perpendicular to the direction of stress, the effective area shall be lesser of the minimum bedded area or the minimum cross-sectional area. If bed joints are raked, the effective area shall be correspondingly reduced. Effective areas for cavity walls shall be that of the loaded wythes.

7.4.2.7 Flexural resistance of cavity walls

For computing the flexural resistance, lateral loads perpendicular to the plane of the wall shall be distributed to the wythes according to their respective flexural rigidities.

7.4.2.8 Effective width of intersecting walls

Where a shear wall is anchored to an intersecting wall or walls, the width of the overhanging flange formed by the intersected walls on either side of the shear wall shall not exceed 6 times the thickness of the intersected wall. Limits of the effective flange may be waived if justified. Only the effective area of the wall parallel to the shear forces may be assumed to carry horizontal shear.

7.4.3 Supports

7.4.3.1 Vertical support

Structural members providing vertical support of masonry shall provide a bearing surface on which the initial bed joint shall not be less than 6 mm or more than 25 mm and shall be of noncombustible materials, except where masonry is a nonstructural decorative feature or wearing surface.

7.4.3.2 Vertical deflection

Elements supporting masonry shall be designed so that their vertical deflection does not exceed $1/600$ of the clear span under total loads. Lintels shall be supported on each end such that allowable stresses in the supporting masonry are not exceeded. The minimum bearing length shall be 100 mm.

7.4.3.3 Lateral support

- (a) Lateral support of masonry may be provided by cross walls, columns, piers, counter forts or buttresses when spanning horizontally or by floors, beams or roofs when spanning vertically.
- (b) Lateral supports for a masonry element such as load bearing wall or column shall be provided to
 - (i) limit the slenderness of a masonry element so as to prevent or reduce possibility of buckling of the member due to vertical loads; and
 - (ii) resist the horizontal components of forces so as to ensure stability of a structure against overturning.
- (c) From consideration of slenderness (i.e. requirement b(i) above), masonry elements may be considered to be laterally supported if
 - (i) in case of a wall, where slenderness ratio is based on effective height, floor/roof slab (or beams and slab) irrespective of the direction of span, bears on the supported wall as well as cross walls, to the extent of at least 100 mm;

- (ii) in case of a wall, when slenderness ratio is based on its effective length, a cross wall/pier/buttress of thickness equal to or more than half the thickness of the supported wall or 125 mm, whichever is more and average length equal to or more than one-fifth of the height of the wall, is built at right angle to the wall and properly bonded;
- (iii) in case of a column, an RC or timber beam/RS joist/roof truss, is supported on the column. In this case, the column will not be considered to be laterally supported in the direction at right angle to it; and
- (iv) in case of a column, an RC beam forming a part of beam and slab construction, is supported on the column, and the slab adequately bears on stiffening walls. This construction will provide lateral support to the column, in the direction of both horizontal axes.

7.4.4 Stability

A wall or column subject to vertical and lateral loads may be considered to provide adequate lateral support from consideration of stability, if the construction providing the support is capable of resisting the following forces:

- (a) Simple static reactions at the point of lateral support to all the lateral loads; plus
- (b) A lateral load equal to 2.5% of the total vertical load that the wall or column is designated to carry at the point of lateral support.

7.4.4.1 In case of load bearing buildings up to five storeys, stability requirements may be considered to have been satisfied if the following conditions are met.

- (a) Height to width ratio of building does not exceed 2.
- (b) Cross walls acting as stiffening walls continuous from outer wall to outer wall or outer wall to a load bearing inner wall, and of thickness and spacing as given in Table 6.7.9 are provided.

If stiffening wall or walls that are in a line, are interrupted by openings, length of solid wall or walls in the zone of the wall that is to be stiffened shall be at least one-fifth of the height of the opening.

- (c) Floors and roof either bear on cross walls or are properly anchored to those walls such that all lateral loads are safely transmitted to those walls and through them to the foundation.
- (d) Cross walls are built jointly with the bearing walls and jointly mortared, or interconnected by tothing.

Cross walls may be anchored to walls to be supported by ties of noncorrosive metal of minimum section 6 x 35 mm and length 60 mm with ends bent at least 50 mm, maximum vertical spacing of ties being 1.2 m.

Table 6.7.9: Thickness and Spacing of Stiffening Walls

Thickness of Load Bearing Wall to be Stiffened (mm)	Height of Storey not to Exceed (m)	Stiffening Wall *		
		Thickness not less than		Maximum spacing (m)
		1 to 3 storeys (mm)	4 and 5 storeys (mm)	
100	3.2	100	-	4.5
200	3.2	100	200	6.0
300	3.4	100	200	8.0
above 300	5.0	100	200	8.0

* Storey height and maximum spacing as given are centre to centre dimensions.

7.4.4.2 In case of walls exceeding 8 m in length, safety and adequacy of lateral supports shall always be checked by structural analysis.

7.4.4.3 A trussed roofing may not provide lateral support unless special measures are adopted to brace and anchor the roofing. However, in case of residential and similar buildings of conventional design with trussed roofing having cross walls, it may be assumed that stability requirements are met by the cross walls and structural analysis for stability may be dispensed with.

7.4.4.4 In case of walls exceeding 8 m in length, safety and adequacy of lateral supports shall always be checked by structural analysis.

7.4.4.5 A trussed roofing may not provide lateral support unless special measures are adopted to brace and anchor the roofing. However, in case of residential and similar buildings of conventional design with trussed roofing having cross walls, it may be assumed that stability requirements are met by the cross walls and structural analysis for stability may be dispensed with.

7.4.4.6 In case of external walls of basement and plinth, stability requirements of Sec 7.4.4 may be considered to be satisfied if :

- Bricks used in basement and plinth have a minimum crushing strength of 5 N/mm² and mortar used in masonry is of Type M₃ or better,
- Clear height of ceiling in basement does not exceed 2.6 m,
- In the zone of action of soil pressure on basement walls, traffic load excluding any surcharge due to adjoining buildings does not exceed 5 kN/m²,
- Minimum thickness of basement walls is in accordance with Table 6.7.10.

In case there is surcharge on basement walls from adjoining buildings, thickness of basement walls shall be based on structural analysis.

Table 6.7.10: Minimum Thickness of Basement Wall

Minimum Nominal Thickness of Basement Wall (mm)	Height of the Ground above Basement Floor Level	
	Wall Loading (Permanent Load)	
	Less than 50 kN/m	More than 50 kN/m
375	2.0 m	2.5 m
250	1.4 m	1.8 m

7.4.4.7 Free standing wall

Free standing walls, subject to wind pressure or seismic forces shall be designed on the basis of permissible tensile stress in masonry or stability consideration. However in Seismic Zones 1 and 2, free standing walls may be proportioned without making any design calculations with the help of Table 6.7.11 provided the mortar used is of type not leaner than M₃. For parapet wall see Sec 7.4.9.4.

7.4.5 Structural Continuity

Intersecting structural elements intended to act as a unit shall be anchored together to resist the design forces. Walls shall be anchored together to all floors, roofs or other elements which provide lateral support for the wall. Where floors or roofs are designed to transmit horizontal forces to walls, the anchorages to the walls shall be designed to resist the horizontal forces.

Table 6.7.11: Height to Thickness Ratio of Free Standing Wall

Design Wind Pressure, N/m ²	Height to Thickness Ratio
Up to 300	10
600	7
900	5
1100	4

Note: Height is to be taken from 150 mm below ground level or top of footing/ foundation block, whichever is higher, and up to the top edge of the wall.

7.4.5.1 Multi-wythe Walls

All wythes shall be bonded by grout or tied together by corrosion resistant wall ties or joint reinforcement as follows:

- (a) Wall Ties in Cavity Wall Construction: Wall ties shall be of sufficient length to engage all wythes. The portion of the wall ties within the wythe shall be completely embedded in mortar or grout. The ends of the wall ties shall be bent to 90 degree angles with an extension not less than 50 mm long. Wall ties not completely embedded in mortar or grout between wythes shall be a single piece with each end engaged in each wythe.

There shall be at least one 6 mm diameter wall tie for each 0.45 m² of wall area. For cavity walls in which the width of the cavity is greater than 75 mm, but not more than 115 mm, at least one 6 mm diameter wall tie for each 0.3 m² of wall area shall be provided.

Ties in alternate courses shall be staggered. The vertical distance between ties shall not exceed 600 mm. The horizontal distance between ties shall not exceed 900 mm. Additional ties spaced not more than 900 mm apart shall be provided around and within 300 mm of the opening. Wall ties of different size and spacing may be used if they provide equivalent strength between wythes.

- (b) Wall Ties for Grouted Multi-wythe Construction: The two wythes shall be bonded together with at least 6 mm diameter steel wall ties for each 0.20 m² of area. Wall ties of different size and spacing may be used if they provide equivalent strength between wythes.
- (c) Joint Reinforcement: Prefabricated joint reinforcement for masonry walls shall have a minimum of one cross wire of at least 3 mm diameter steel for each 0.2 m² of wall area. The vertical spacing of the joint reinforcement shall not exceed 400 mm. The longitudinal wires shall be thoroughly embedded in the bed joint mortar. The joint reinforcement shall engage all wythes.

Where the space between tied wythes is filled with grout or mortar, the allowable stresses and other provisions for masonry bonded walls shall apply. Where the space is not filled, tied walls shall conform to the allowable stress, lateral support, thickness (excluding cavity), height and tie requirements of cavity walls.

7.4.6 Joint Reinforcement and Protection of Ties

The minimum mortar cover between ties or joint reinforcement and any exposed face shall be 15 mm. The thickness of grout or mortar between masonry units and joint reinforcement shall not be less than 6 mm, except that smaller diameter reinforcement or bolts may be placed in bed joints which are at least twice as thick as the diameter of the reinforcement.

7.4.7 Pipes and Conduits

Pipe or conduit shall not be embedded in any masonry so as to reduce the capacity to less than that necessary for required stability or required fire protection, except the following:

- (a) Rigid electrical conduit may be embedded in structural masonry when their location has been detailed on the approved plan.
- (b) Any pipe or conduit may pass vertically or horizontally through any masonry by means of a sleeve at least large enough to pass any hub or coupling on the pipeline. Such sleeves shall not be placed closer than three diameters, centre to centre, nor shall they unduly impair the strength of construction.
- (c) Placement of pipes or conduits in unfilled cores of hollow unit masonry shall not be considered as embedment.

7.4.8 Loads and Load Combination

7.4.8.1 Design loads

All design loads and other forces to be taken for the design of masonry structures shall conform to Chapter 2, Loads.

7.4.8.2 Load dispersion

The angle of dispersion of vertical load on walls shall be taken as not more than 30° from the vertical.

7.4.8.3 Distribution of concentrated vertical loads in walls

The length of wall, laid up in running bond, which may be considered capable of working at the maximum allowable compressive stresses to resist vertical concentrated loads, shall not exceed the centre to centre distance between such loads, nor the width of bearing area plus four times the wall thickness. Concentrated vertical loads shall not be assumed distributed across continuous vertical mortar or control joints unless elements designed to distribute the concentrated vertical loads are employed.

7.4.8.4 Loads on non-bearing wall

Masonry walls used as interior partition or as exterior surfaces of building which do not carry vertical loads imposed by other elements of the building shall be designed to carry their own weight plus any superimposed finish and lateral forces. Bonding or anchorage of nonbearing walls shall be adequate to support the walls and to transfer lateral forces to the supporting structures.

7.4.8.5 Load combinations

Load combination for design of masonry structures shall conform to requirements of Sec 2.7 Chapter 2 Part 6.

7.4.9 Minimum Design Dimensions

7.4.9.1 Minimum thickness of load bearing walls

The nominal thickness of masonry bearing walls in building shall not be less than 250 mm.

Exception:

Stiffened solid masonry bearing walls in one-storey buildings may have a minimum effective thickness of 165 mm when not over 3 m in height, provided that when gable construction is used an additional 1.5 m height may be permitted at the peak of the gable.

7.4.9.2 Variation in thickness

When a change in thickness due to minimum thickness requirements occurs between floor levels, the greater thickness shall be carried up to the higher floor level.

7.4.9.3 Decrease in thickness

When walls of masonry of hollow units or masonry bonded hollow walls are decreased in thickness, a course or courses of solid masonry shall be constructed between the walls below and the thinner wall above, or special units or construction shall be used to transmit the loads from wythes to the walls below.

7.4.9.4 Parapet wall

Parapet walls shall be at least 200 mm thick and height shall not exceed 4 times the thickness. The parapet wall shall not be thinner than the wall below.

7.5 Design of Unreinforced Masonry

7.5.1 General

The requirements of this Section are applicable to unreinforced masonry in addition to the requirements of Sec 7.4.

7.5.2 Design of Members Subjected to Axial Compression

The stresses due to compressive forces applied at the centroid of any load bearing wall, column and pilaster may be computed by Eq. 6.7.22 below assuming uniform distribution over the effective area.

$$f_a = \frac{P}{A_e} \quad (6.7.22)$$

7.5.3 Design of Members Subjected to Combined Bending and Axial Compression

- (a) Compressive stresses due to combined bending and axial load shall satisfy the requirements of Sec 7.3.5.
- (b) Resultant tensile stress due to combined bending and axial load shall not exceed the allowable flexural tensile stress, F_t as specified in Sec 7.3.

7.5.4 Design of Members Subjected to Flexure

Stresses due to flexure calculated by Eq. 6.7.23 below shall not exceed the values given in Sec 7.3.5.

$$f_b = \frac{Mc}{I} \quad (6.7.23)$$

7.5.5 Design of Members Subjected to Shear

Shear calculations in flexural members and shear walls shall be based on Eq. 6.7.24 below.

$$f_v = \frac{V}{A_e} \quad (6.7.24)$$

7.5.6 Design of Arches

Geometrical form and the cross-sectional dimensions of masonry arch shall be selected such that the line of thrust at any section of the arch is kept within the middle third of the section of the arch rib. The elastic theory of arches shall be permitted for the analysis of unreinforced masonry arches. All supports of arches shall be capable of developing the required horizontal thrust without suffering unacceptable displacements. Every arch must be designed to resist the stresses due to the following loads:

- (a) Gravity loads :
 - (i) Dead loads shall be placed in conformity with their actual distribution.
 - (ii) Live loads shall be positioned to cover entire span or part of the span as necessary to produce the maximum stresses at the crown, springing and all other sections of the arch rib.
- (b) Loads due to temperature change.
- (c) Shrinkage load due to setting and hardening.
- (d) Shortening of arch rib under thrust caused by loads.

7.5.7 Footings and Corbels

The slope of footing and corbelling (measured from the horizontal to the face of the corbelled surface) shall not be less than 60 degrees.

The maximum horizontal projection of corbelling from the plane of the wall shall be such that stress at any section does not exceed the allowable value.

7.6 Design of Reinforced Masonry

7.6.1 General

The requirements of this Section are in addition to those specified in Sec 7.4 and are applicable to reinforced masonry. Plain bars larger than 6 mm in diameter shall not be used.

7.6.1.1 Assumptions

The following assumptions shall be applicable for this Section.

- (a) Masonry carries no tensile stress.
- (b) Reinforcement is completely surrounded by and bonded to masonry material so that they work together as a homogeneous material within the range of working stresses.

7.6.2 Design of Members Subjected to Axial Compression

Stresses due to compressive forces applied at the centroid of load bearing wall, column and pilaster may be computed assuming uniform distribution over the effective area. Stress shall be calculated from Eq. 6.7.25 below:

$$f_a = \frac{P}{A_e} \quad (6.7.25)$$

7.6.3 Design of Members Subjected to Combined Bending and Axial Compression

Stress due to combined bending and axial loads shall satisfy the requirements of Sec 7.3.5. Columns and walls subjected to bending with or without axial loads shall meet all applicable requirements for flexural design.

The design of walls with an (h/t) ratio larger than 30 shall be based on forces and moments determined from analysis of structure. Such analysis shall take into account influence of axial loads and variable moment of inertia on member stiffness and fixed end moments, effect of deflections on moments and forces, and the effects of duration of loads.

7.6.4 Design of Members Subjected to Shear Force

Shearing stresses in flexural members and shear walls shall be computed by

$$f_v = \frac{V}{bjd} \quad (6.7.26)$$

When the computed shear stress exceeds the allowable value, web reinforcement shall be provided and designed to carry the total shear force. Both vertical and horizontal shear stresses shall be considered. The area required for shear reinforcement placed perpendicular to the longitudinal reinforcement shall be computed by Eq. 6.7.27 below:

$$A_v = \frac{sV}{F_s d} \quad (6.7.27)$$

Spacing of vertical shear reinforcement shall not exceed d/2, nor 600 mm. Inclined shear reinforcement shall have a maximum spacing of $0.375d(1 + \cot\alpha)$, but not greater than 600 mm, where α is the acute angle between inclined bar and the horizontal.

7.6.5 Design of Members Subjected to Flexural Stress

7.6.5.1 Rectangular elements

Rectangular flexural elements shall be designed in accordance with the following equations or other methods based on the simplified assumptions.

(a) Compressive stress in the masonry:

$$f_b = \frac{M}{bd^2} \left(\frac{2}{jk} \right) \quad (6.7.28)$$

(b) Tensile stress in the longitudinal reinforcement:

$$f_s = \frac{M}{A_s j d} \quad (6.7.29)$$

(c) Design coefficients :

$$k = [(np)^2 + 2np]^{1/2} - np \quad (6.7.30)$$

Or,
$$k = \frac{1}{1 + \frac{f_s}{n f_b}} \quad (6.7.31)$$

$$j = 1 - \frac{k}{3} \quad (6.7.32)$$

7.6.5.2 Nonrectangular sections

Flexural elements of nonrectangular cross-section shall be designed in accordance with the assumptions given in Sec 7.4.2.1 and 7.6.1.1.

7.6.5.3 Lateral support

The clear distance between lateral supports of a beam shall not exceed 32 times the least depth of compression area.

7.6.5.4 Effective width

In computing flexural stresses in walls where reinforcement occurs, the effective width assumed for running bond masonry shall not exceed 6 times the nominal wall thickness or the centre to centre distance between reinforcement. Where stack bond is used, the effective width shall not exceed 3 times the nominal wall thickness or the centre to centre distance between reinforcement or the length of one unit, unless grouted solid using open-ended joints.

7.6.5.5 Bond

In flexural members in which tensile reinforcement is parallel to the compressive face, the bond stress shall be computed by the formula:

$$u = \frac{V}{\sum_o j d} \quad (6.7.33)$$

7.6.6 Reinforcement Requirements and Details

7.6.6.1 Column reinforcement

(a) Vertical Reinforcement: The area of vertical reinforcement shall not be less than $0.005 A_e$ and not more than $0.04 A_e$. At least four 10 mm \square bars shall be provided.

- (b) Lateral Ties: All longitudinal bars for columns shall be enclosed by lateral ties. Lateral support shall be provided to the longitudinal bars by the corner of a complete tie having an included angle of not more than 135 degrees or by a hook at the end of a tie. The corner bars shall have such support provided by a complete tie enclosing the longitudinal bars. Alternate longitudinal bars shall have such lateral support provided by ties and no bar shall be farther than 150 mm from such a laterally supported bar.

Lateral ties and longitudinal bars shall be placed not less than 40 mm and not more than 125 mm, from the surface of the column. Lateral ties may be against the longitudinal bars or placed in the horizontal bed joint if the requirements of Sec 4.4.6 are met. Spacing of ties shall not be more than 16 times longitudinal bar diameter, 48 times tie bar diameter or the least dimension of the column but not more than 450 mm.

Ties shall be at least 6 mm in diameter for 22 mm diameter or smaller longitudinal bars and 10 mm in diameter for larger longitudinal bars. Ties less than 10 mm in diameter may be used for longitudinal bars larger than 22 mm in diameter, provided the total cross-sectional area of such smaller ties crossing a longitudinal plane is equal to that of the larger ties at their required spacing.

- (c) Anchor Bolt Ties: Additional ties shall be provided around anchor bolts which are set in the top of the column. Such ties shall engage at least four bolts or, alternatively at least four vertical column bars or a combination of bolts and bars totaling four in number. Such ties shall be located within the top 125 mm of the column and shall provide a total of 250 square millimeters or more in cross-sectional area. The upper most ties shall be within 50 mm of the top of the column.

7.6.6.2 Maximum reinforcement size

The maximum size of reinforcing bars shall be 35 mm. Maximum steel area in cell shall be 6 percent of the cell area without splices and 12 percent of cell area with splices.

7.6.6.3 Spacing of longitudinal reinforcement

The clear distance between parallel bars, except in columns, shall not be less than the nominal diameter of the bars or 25 mm, except that bars in a splice may be in contact. This clear distance requirement applies to the clear distance between a contact splice and adjacent splices or bars. The minimum clear distance between parallel bars in columns shall be two and one-half times the bar diameter.

The clear distance between the surface of a bar and any surface of a masonry unit shall not be less than 6 mm for fine grout and 12 mm for coarse grout. Cross webs of hollow units may be used as support for horizontal reinforcement.

All reinforcing bars, except joint reinforcing, shall be completely embedded in mortar or grout and have a minimum cover, including the masonry unit, as specified below:

- (a) 20 mm when not exposed to weather
- (b) 40 mm when exposed to weather
- (c) 50 mm when exposed to soil

7.6.6.4 Anchorage of Flexural Reinforcement

- (a) The tension or compression in any bar at any section must be developed on each side of that section by the required development length. The development length of the bar may be achieved by a combination of an embedment length, anchorage or, for tension only, hooks.

The required development length for deformed bars or deformed wires shall be calculated by:

For bar in tension,

$$l_d = 0.29d_b f_s \quad (6.7.34)$$

For bar in compression,

$$l_d = 0.22d_b f_s \quad (6.7.35)$$

Development length for plain bars shall be 2.0 times the length calculated by Eq. 6.7.34.

- (b) Except at supports, or at the free end of cantilevers, every reinforcing bar shall be extended beyond the point at which it is no longer needed to resist tensile stress for a distance equal to 12 bar diameters or the depth of the flexural member, whichever is greater. No flexural bars shall be terminated in a tensile zone unless one of the following conditions is satisfied:
 - (i) The shear is not over one-half of that permitted, including allowance for shear reinforcement, if any.
 - (ii) Additional shear reinforcement in excess of that required is provided each way from the cutoff a distance equal to the depth of the beam. The shear reinforcement spacing shall not exceed $d/8r_b$ where r_b is the ratio of the area of bars cutoff to the total area of bars at the section.
 - (iii) The continuing bars provide double the area required for flexure at that point or double the perimeter required for reinforcing bond.

- (c) At least one third of the total reinforcement provided for negative moment at the support shall be extended beyond the extreme position of the point of inflection a distance sufficient to develop one half the allowable stress in the bar, one sixteenth of the clear span, or the depth d of the member, whichever is greater.
- (d) Tensile reinforcement of negative moment in any span of a continuous restrained or cantilever beam, or in any member of a rigid frame, shall be adequately anchored by reinforcing bond, hooks or mechanical anchors in or through the supporting member.
- (e) At least one third of the required positive moment reinforcement in simple beams or at the freely supported end of continuous beams shall extend along the same face of the beam into the support at least 150 mm. At least one fourth of the required positive moment reinforcement at the continuous end of continuous beams shall extend along the same face of the beam into the support at least 150 mm.
- (f) Compression reinforcement in flexural members shall be anchored by ties or stirrups not less than 6 mm in diameter, spaced not farther apart than 16 bar diameters or 48 tie diameters whichever is smaller. Such ties or stirrups shall be used throughout the distance where compression steel is required.
- (g) In regions of moment where the design tensile stresses in the steel are greater than 80 percent of the allowable steel tensile stress (F_s), the lap length of splices shall be increased not less than 50 percent of the minimum required length. Other equivalent means of stress transfer to accomplish the same 50 percent increase may be used.

7.6.6.5 Anchorage of shear reinforcement

- (a) Single separate bars used as shear reinforcement shall be anchored at each end by one of the following methods:
 - (i) Hooking tightly around the longitudinal reinforcement through 180 degrees.
 - (ii) Embedment above or below the mid-depth of the beam on the compression side a distance sufficient to develop the stress in the bar for plain or deformed bars.
 - (iii) By a standard hook (see Sec 7.6.6.6) considered as developing 50 N/mm², plus embedment sufficient to develop the remainder of the stress to which the bars are subject. The effective embedded length shall not be assumed to exceed the distance between the mid-depth of the beam and the tangent of the hook.

- (b) The ends of bars forming single U or multiple U stirrups shall be anchored by one of the methods specified above or shall be bent through an angle of at least 90 degrees tightly around a longitudinal reinforcing bar not less in diameter than the stirrup bar, and shall project beyond the bend at least 12 diameters of the stirrup.
- (c) The loops or closed ends of single U or multiple U stirrups shall be anchored by bending around the longitudinal reinforcement through an angle of at least 90 degrees and project beyond the end of the bend at least 12 diameters of the stirrup.

7.6.6.6 Hooks

- (a) The term "standard hook" shall mean one of the following:
- (i) A 180 degree turn plus an extension of at least 4 bar diameters but not less than 65 mm at the free end of the bar.
- (ii) 90 degree turn plus an extension of at least 12 bar diameters at the free end of the bar.
- (iii) For stirrup and tie anchorage only either a 90 degree or a 135 degree turn, plus an extension of at least 6 bar diameters but not less than 65 mm at the free end of the bar.
- (b) The diameter of bend measured on the inside of the bar other than stirrups and ties, shall not be less than that set forth in Table 6.7.12.

Table 6.7.12: Minimum Diameter of Bend

Bar Diameter	Minimum Diameter of Bend
6 to 25 mm	6 bar diameters
8 to 35 mm	8 bar diameters

- (c) Inside diameter of bend for 12 mm diameter or smaller stirrups and ties shall not be less than 4 bar diameters. Inside diameter of bend for 16 mm diameter or larger stirrups and ties shall not be less than that given in Table 6.7.12.
- (d) Hooks shall not be permitted in the tension portion of any beam, except at the ends of simple or cantilever beams or at the freely supported ends of continuous or restrained beams.
- (e) Hooks shall not be assumed to carry a load which would produce a tensile stress in the bar greater than 50 N/mm².

- (f) Hooks shall not be considered effective in adding to the compressive resistance of bars.
- (g) Any mechanical device capable of developing the strength of the bar without damage to the masonry may be used in lieu of a hook. Data must be presented to show the adequacy of such devices.

7.6.6.7 Splices

The amount of lap of lapped splices shall be sufficient to transfer the allowable stress of the reinforcement as in Sec 7.6.6.4. In no case shall the length of the lapped splice be less than 30 bar diameters for compression and 40 bar diameters for tension.

Welded or mechanical connections shall develop 125 percent of the specified yield strength of the bar in tension, except for connections of compression bars in columns that are not part of the seismic system and are not subject to flexure, where the compressive strength only need be developed.

When adjacent splices in grouted masonry are separated by 75 mm or less, the lap length shall be increased by 30 percent or the splice may be staggered at least 24 bar diameters with no increase in lap length.

7.7 Strength Design of Slender Walls and Shear Walls

7.7.1 Design of Slender Walls

In lieu of the procedure set forth in Sec 7.6, the procedures prescribed in this Section, which consider the slenderness of walls by representing effects of axial forces and deflection in calculation of moments, may be used when the vertical load stress at the location of maximum moment computed by Eq. 6.7.36 does not exceed $0.04f'_m$. The value of f'_m shall not exceed 40 N/mm².

$$\frac{P_w + P_f}{A_g} \leq 0.04f'_m \quad (6.7.36)$$

Slender masonry walls shall have a minimum nominal thickness of 150 mm.

7.7.1.1 Slender wall design procedure

- (a) Maximum Reinforcement: The reinforcement ratio shall not exceed $0.5\bar{\rho}_b$ where $\bar{\rho}_b$ is the balanced steel ratio.
- (b) Moment and Deflection Calculation: All moments and deflections of slender walls shall be calculated based on simple support conditions at top and bottom. For other support and fixity conditions, moments and deflections shall be calculated using established principles of mechanics.

7.7.1.2 Strength design

- (a) Loads: Factored loads shall be determined in accordance with Chapter 2, Loads.
- (b) Required Moment: Required moment and axial force shall be determined at the mid-height of the wall and shall be used for design. The factored moment, M_u at the mid-height of the wall shall be determined by Eq. 6.7.37.

$$M_u = \frac{w_u h^2}{8} + P_u \frac{e}{2} + (P_{uw} + P_{uf}) \Delta_u \quad (6.7.37)$$

Where,

Δ_u = horizontal deflection at mid-height under factored load; P - Delta effects shall be included in deflection calculation.

e = eccentricity of P_u

P_u = axial load at mid-height of wall, including tributary wall weight.

$$= P_{uw} + P_{uf}$$

- (c) Design Strength: Design strength in flexure is the nominal moment strength, M_n multiplied by the strength reduction factor, ϕ and shall equal or exceed the factored moment, M_u

$$M_u \leq \phi M_n \quad (6.7.38)$$

Where,

M_n = nominal moment strength

$$= A_{se} f_y (d - a/2)$$

A_{se} = effective area of steel

$$= \frac{A_s f_y + P_u}{f_y} \text{ and}$$

a = depth of stress block due to factored loads.

$$= \frac{A_s f_y + P_u}{0.85 f'_m b}$$

The strength reduction factor ϕ for flexure shall be 0.80.

- (d) Design Assumptions: The following are the design assumptions for calculation of nominal strength.
- (i) Nominal strength of singly reinforced masonry wall cross-sections subject to combined flexure and axial load shall be based on applicable conditions of equilibrium and compatibility of strains.
 - (ii) Strain in reinforcement and masonry walls shall be assumed directly proportional to the distance from the neutral axis.
 - (iii) Maximum usable strain at extreme masonry compression fibre shall be assumed equal to 0.003.
 - (iv) Stress in reinforcement below specified yield strength f_y shall be taken as E_s times steel strain. For strains greater than that corresponding to f_y stress in reinforcement shall be considered independent of strain and equal to f_y .
 - (v) Tensile strength of masonry walls shall be neglected in flexural calculations of strength, except for deflection calculation.
 - (vi) Relationship between masonry compressive stress and masonry strain may be assumed to be rectangular as defined by the following:
 - Masonry stress of $0.85f'_m$ shall be assumed uniformly distributed over an equivalent compression zone bounded by edges of the cross-section and a straight line located parallel to the neutral axis at a distance $a = 0.85c$ from the fibre of maximum compressive strain.
 - Distance c from fibre of maximum strain to the neutral axis shall be measured in a direction perpendicular to that axis.

7.7.1.3 Deflection calculation

The mid-height deflection, Δ_s under service lateral and vertical loads (without load factors) shall be limited to:

$$\Delta_s = 0.007h \quad (6.7.39)$$

The mid-height deflection shall be computed by:

When, $M_{ser} \leq M_{cr}$

$$\Delta_s = \frac{5M_s h^2}{48E_m I_g} \quad (6.7.40)$$

When, $M_{cr} < M_{ser} < M_n$

$$\Delta_s = \frac{5M_{cr} h^2}{48E_m I_g} + 5 \frac{(M_{ser} - M_{cr}) h^2}{48E_m I_{cr}} \quad (6.7.41)$$

The cracking moment strength of the wall M_{cr} shall be determined by:

$$M_{cr} = S f_y \quad (6.7.42)$$

The modulus of rupture, f_r shall be determined from Table 6.7.13.

Table 6.7.13: Values of the Modulus of Rupture, f_r

Type of Masonry	Fully Grouted	Partially Grouted
Solid Masonry	$0.17\sqrt{f'_m} \leq 0.65 \text{ N/mm}^2$	Not allowed
Hollow Unit Masonry	$0.33\sqrt{f'_m} \leq 1.2 \text{ N/mm}^2$	$0.21\sqrt{f'_m} \leq 0.65 \text{ N/mm}^2$

7.7.2 Design of Shear Walls

Based on ultimate strength design, the procedures described below may be used as an alternative to the procedure specified in Sec 7.6 for the design of reinforced hollow unit masonry shear walls. Provisions for quality control during construction of the shear wall are specified in Sec 7.3.4

7.7.2.1 Required strength

The required strength to resist different combinations of loads shall be determined in accordance with Sec 2.7.3.1 Chapter 2 of this Part.

7.7.2.2 Design strength

Shear walls shall be proportioned such that the design strength exceeds the required strength. Design strength in terms of axial force, shear force and moment provided by the shear wall shall be computed as the nominal strength multiplied by the strength reduction factor ϕ . Strength reduction factor ϕ shall be as follows:

- (a) For axial load and axial load with flexure $\phi = 0.65$
- (b) For members with f_y less than 410 N/mm^2 and with symmetrical reinforcement, ϕ may be increased linearly to 0.85 as ϕP_n decreases from $0.10f'_m A_e$ or $0.25P_b$ to zero.

For solid grouted walls P_b may be calculated using:

$$P_b = 0.85 f'_m b a_b \quad (6.7.43a)$$

Where,

$$a_b = 0.85 \left[e_{mu} / (e_{mu} + f_y / E_s) \right] d \quad (6.7.43b)$$

- (c) For shear $\phi = 0.60$. The shear strength reduction factor may be increased to 0.80 for any shear wall when its nominal shear strength exceeds the shear corresponding to development of its nominal flexural strength for the factored load combination.

7.7.2.3 Design Assumptions for Nominal Strength

- (a) Nominal strength of shear wall cross-sections shall be based on assumptions specified in Sec 7.7.1.2(d).
- (b) The maximum usable strain e_{mu} , at the extreme masonry compression fibre shall not exceed 0.003.
- (c) f'_m shall not be less than 7 N/mm² or greater than 20 N/mm².

7.7.2.4 Axial Strength

The nominal axial strength of shear walls supporting axial loads only shall be calculated by Eq 6.7.44.

$$P_o = 0.85f'_m(A_e - A_s) + f_yA_s \quad (6.7.44)$$

The shear wall shall be designed for the axial strength P_u such that

$$P_u \leq \phi(0.80)P_o \quad (6.7.45)$$

7.7.2.5 Shear strength

- (a) The nominal shear strength shall be determined by the provisions as specified in (b) or (c) below. The maximum nominal shear strength values are given in Table 6.7.14.

Table 6.7.14: Maximum Nominal Shear Strength Values

$\frac{M^*}{Vd}$	$\frac{V_n}{A_e\sqrt{f'_m}}$
≤ 0.25	72.0
≥ 1.00	48.0

* M is the maximum bending moment that occurs simultaneously with the shear load V at the section under consideration. Interpolation may be by straight line for M/Vd values between 0.25 and 1.00.

- (b) The nominal shear strength of shear walls except for shear walls specified in (c) below shall be determined by Eq. 6.7.46.

$$V_n = V_m + V_s \quad (6.7.46)$$

Where,

$$V_m = 0.083C_d A_{mv} \sqrt{f'_m} \quad (6.7.47)$$

The value of C_d in Eq. 6.7.47 is given as:

$$C_d = 2.4 \text{ for } \frac{M}{vd} \leq 0.25 \quad (6.7.48a)$$

$$C_d = 1.2 \text{ for } \frac{M}{vd} \geq 1.0 \quad (6.7.48b)$$

$$V_s = A_{mv} \rho_n f_y \quad (6.7.48c)$$

- (c) For a shear wall whose nominal shear strength exceeds the shear corresponding to development of its nominal flexural strength, two shear regions exist.

- (i) For all cross-sections within the region defined by the base of the shear wall and a plane at a distance L_w above the base of the shear wall, the nominal shear strength shall be determined by Eq. 6.7.49

$$V_n = A_{mv} \rho_n f_y \quad (6.7.49)$$

The required shear strength for this region shall be calculated at a distance $\frac{L_w}{2}$ above the base of the shear wall but not to exceed one-half storey height.

- (ii) For the other region, the nominal shear strength of the shear wall shall be determined by Eq. 6.7.46.

7.7.2.6 Reinforcement

Reinforcement shall be in accordance with the following:

- (a) Minimum reinforcement shall be provided in accordance with Sec 7.8.5.1 for all seismic areas using this method of analysis.
- (b) When the shear wall failure mode is in flexure, the nominal flexural strength of the shear wall shall be at least 1.8 times the cracking moment strength of a fully grouted wall or 3.0 times the cracking moment strength of a partially grouted wall as obtained from Eq. 6.7.42.
- (c) All continuous reinforcement shall be anchored or spliced in accordance with Sec 7.6.6.4 with $f_s = 0.5f_y$.

- (d) Vertical reinforcement shall not be less than 50 percent of the horizontal reinforcement.
- (e) Spacing of horizontal reinforcement within the region defined in Sec 7.7.2.5(c) shall not exceed three times the nominal wall thickness or 600 mm, whichever is smaller.

7.7.2.7 Boundary member

Boundary members shall be as follows:

- (a) The need for boundary members at boundaries of shear wall shall be determined using the provisions set forth in (b) or (c) below.
- (b) Boundary members shall be provided when the failure mode is flexure and the maximum extreme fibre stress exceeds $0.2f'_m$. The boundary members may be discontinued where the calculated compressive stresses are less than $0.15f'_m$. Stresses may be calculated for the factored forces using a linearly elastic model and gross section properties.
- (c) When the failure mode is flexure, boundary member shall be provided to confine all vertical reinforcement whose corresponding masonry compressive stress exceeds $0.4f'_m$. The minimum length of the boundary member shall be 3 times the thickness of the wall.
- (d) Boundary members shall be confined with minimum of 10 mm diameter bars at a maximum of 200 mm spacing or equivalent within the grouted core and within the region defined by the base of the shear wall and a plane at a distance L_w above the base of the shear wall.

7.8 Earthquake Resistant Design

7.8.1 General

All masonry structures constructed in the Seismic Zones 2, 3 and 4 shown in Figure 6.2.13 shall be designed in accordance with the provisions of this Section.

7.8.2 Loads

Seismic forces on masonry structures shall be determined in accordance with the provisions of Sec 2.5 Chapter 2 of this Part.

7.8.3 Materials

- (a) Well burnt clay bricks and concrete hollow blocks having a crushing strength not less than 12 N/mm^2 shall be used.
- (b) Mortar not leaner than M_3 shall be used for masonry constructions.

7.8.4 Provisions for Seismic Zone 2 and 3

7.8.4.1 Wall Reinforcement

Vertical reinforcement of at least 12 mm diameter shall be provided continuously from support to support at each corner, at each side of each opening, at the ends of walls and at a maximum spacing of 1.2 m horizontally throughout the wall. Horizontal reinforcement not less than 12 mm diameter shall be provided:

- (a) at the bottom and top of wall openings and shall extend at least 40 bar diameters, with a minimum of 600 mm, past the opening,
- (b) continuously at structurally connected roof and floor levels and at the top of walls,
- (c) at the bottom of the wall or in the top of the foundations when dowelled to the wall,
- (d) at maximum spacing of 3.0 m unless uniformly distributed joint reinforcement is provided. Reinforcement at the top and bottom of openings when continuous in the wall may be used in determining the maximum spacing specified in item (a) above.

7.8.4.2 Stack bond

Where stack bond is used, the minimum horizontal reinforcement ratio shall be $0.0007bt$. This ratio shall be satisfied by uniformly distributed joint reinforcement or by horizontal reinforcement spaced not more than 1.2 m and fully embedded in grout or mortar.

7.8.4.3 Columns

Columns shall be reinforced as specified in Sec 7.6.6.1.

7.8.5 Provisions for Seismic Zone 4

All masonry structures built in Seismic Zone 4 shall be designed and constructed in accordance with requirements for Seismic Zone 2 and with the following additional requirements and limitations.

Reinforced hollow unit stack bond construction which is part of the seismic resisting system shall use open-end units so that all head joints are made solid, shall use bond beam units to facilitate the flow of grout and shall be grouted solid.

7.8.5.1 Wall reinforcement

Reinforced masonry walls shall be reinforced with both vertical and horizontal reinforcement. The sum of the areas of horizontal and vertical reinforcement shall be at least 0.002 times the gross cross-sectional area of the wall and the area of reinforcement in either direction shall not be less than 0.0007 times the gross cross-sectional area of the wall. The spacing of reinforcement shall not

exceed 1.20 m. The diameter of reinforcing bar shall not be less than 10 mm except that joint reinforcement may be considered as part of all of the requirements for minimum reinforcement. Reinforcement shall be continuous around wall corners and through intersections. Only reinforcement which is continuous in the wall or element shall be considered in computing the minimum area of reinforcement. Reinforcement with splices conforming to Sec 7.6.6.7 shall be considered as continuous reinforcement.

7.8.5.2 Column reinforcement

The spacing of column ties shall be not more than 225 mm for the full height of columns stressed by tensile or compressive axial overturning forces due to the seismic loads, and 225 mm for the tops and bottoms of all other columns for a distance of one sixth of the clear column height, but not less than 450 mm or maximum column dimension. Tie spacing for the remaining column height shall be not more than 16 bar diameters, 48 tie diameters or the least column dimension, but not more than 450 mm.

7.8.5.3 Stack bond

Where stack bond is used, the minimum horizontal reinforcement ratio shall be $0.0015bt$. If open-end units are used and grouted solid, the minimum horizontal reinforcement ratio shall be $0.0007bt$.

7.8.5.4 Minimum dimension

- (a) Bearing Walls: The nominal thickness of reinforced masonry bearing walls shall be not less than 150 mm except that nominal 100 mm thick load bearing reinforced hollow clay unit masonry walls may be used, provided net area unit strength exceeds 55 N/mm^2 , units are laid in running bond, bar sizes do not exceed 12 mm with no more than two bars or one splice in a cell, and joints are flush cut, concave or a protruding V section.
- (b) Columns: The least nominal dimension of a reinforced masonry column shall be 375 mm except that if the allowable stresses are reduced to 50 percent of the values given in Sec 7.3, the minimum nominal dimension shall be 250 mm.

7.8.5.5 Shear wall

- (a) When calculating shear or diagonal tension stresses, shear walls which resist seismic forces shall be designed to resist 1.5 times the forces specified in Chapter 2, Loads.
- (b) The portion of the reinforcement required to resist shear shall be uniformly distributed and shall be joint reinforcing, deformed bars, or a combination thereof. The maximum spacing of reinforcement in each direction shall be not less than the smaller of one-half the length or height of the element or more than 1.20 m.

Joint reinforcement used in exterior walls and considered in the determination of the shear strength of the member shall conform to the requirement "Joint Reinforcement for Masonry" (UBC Standard No. 24-15) or "Standard Specification for Steel Wire, Plain, for Concrete Reinforcement", (ASTM, A82).

Reinforcement required to resist in-plane shear shall be terminated with a standard hook or with an extension of proper embedment length beyond the reinforcing at the end of the wall section. The hook or extension may be turned up, down or horizontally. Provisions shall be made not to obstruct grout placement. Wall reinforcement terminating in columns or beams shall be fully anchored into these elements.

- (c) Multi-wythe grouted masonry shear walls shall be designed with consideration of the adhesion bond strength between the grout and masonry units. When bond strengths are not known from previous tests, the bond strength shall be determined by test.

7.8.5.6 Hook

The standard hook for tie anchorage shall have a minimum turn of 135 degrees plus an extension of at least 6 bar diameters, but not less than 100 mm at the free end of the bar. Where the ties are placed in the horizontal bed joints, the hook shall consist of a 90 degree bend having a radius of not less than 4 tie diameters plus an extension of 32 tie diameters.

7.8.5.7 Mortar joints between masonry and concrete

Concrete abutting structural masonry such as at starter courses or at wall intersections not designed as true separation joints shall be roughened to a full amplitude of 1.5 mm and shall be bonded to the masonry as per the requirements of this Section as if it were masonry.

7.8.6 Additional Requirements

7.8.6.1 Opening in bearing walls

- (a) Tops of all openings in a storey shall preferably be at the same level so that a continuous band could be provided over them, including the lintels throughout the building.
- (b) The total width of the openings shall not be more than half of the length of the walls between the adjacent cross walls, except as provided in (f) below.
- (c) The opening shall preferably be located away from the corner by a clear distance of at least one-eighth of the height of the opening for Seismic Zones 2 and 3, and one-fourth of the height for Seismic Zone 4.

- (d) The horizontal distance between two openings shall not be less than one-fourth of the height of the shorter opening for Seismic Zones 2 and 3, and one-half of the height for Seismic Zone 4.
- (e) The vertical distance between openings one above the other shall be not less than 600 mm.
- (f) Where openings do not comply with the requirements of (b) and (c) above, they shall be strengthened in accordance with Sec 7.8.6.5.
- (g) If a window or ventilator is to be projected out, the projection shall be in reinforced masonry or concrete and well anchored.
- (h) If the height of an opening is approximately full height of a wall, dividing the wall into two portions, these portions of the wall shall be reinforced with horizontal reinforcement of 6 mm diameter bars at not more than 600 mm intervals, one on inner and one on outer face, properly tied to vertical steel at jambs and corners or junctions of walls where used.
 - (i) The use of arches to span over the openings is a source of weakness and shall be avoided unless steel ties are provided.

7.8.6.2 Strengthening arrangements

All masonry buildings shall be strengthened by the methods specified in Table 6.7.15.

Table 6.7.15: Strengthening of Masonry Buildings for Earthquake

Seismic Zones	No. of Storey	Strengthening Arrangements to be Provided.
1	Up to 4	a) Masonry mortar shall not be leaner than M_3
2, 3	Up to 2 with pitched roof	a) Masonry mortar shall not be leaner than M_3 b) By lintel and roof band (Sec 7.8.6.3) c) By vertical reinforcement at corners and junctions of walls (Sec 7.8.6.4) d) Bracing in plan at tie level for pitched roof*
	3 to 4	a) Masonry mortar shall not be leaner than M_3 b) By lintel and roof band (Sec 7.8.6.3) c) By vertical reinforcement at corners and junctions of walls (Sec 7.8.6.4) d) Vertical reinforcement at jambs of openings (Sec 7.8.6.5) e) Bracing in plan at tie level for pitched roof*

Seismic Zones	No. of Storey	Strengthening Arrangements to be Provided.
4	Up to 4	a) Masonry mortar shall not be leaner than M_3 b) By lintel and roof band (Sec 7.8.6.3) c) By vertical reinforcement at corners and junctions of walls (Sec 7.8.6.4) d) Vertical reinforcement at jambs of openings (Sec 7.8.6.5) e) Bracing in plan at tie level for pitched roof*
<ul style="list-style-type: none"> • At tie level all the trusses and the gable end shall be provided with diagonal bracing in plan so as to transmit the lateral shear due to earthquake force to the gable walls acting as shear walls at the ends. 		

7.8.6.3 Bands

Roof band need not be provided underneath reinforced concrete or brickwork slabs resting on bearing walls, provided that the slabs are continuous over parts between crumple sections, if any, and cover the width of end walls fully.

The band shall be made of reinforced concrete with f'_c not less than 20 N/mm² or reinforced brickwork in cement mortar not leaner than 1: 4. The bands shall be to the full width of the wall and not less than 75 mm in depth and shall be reinforced as indicated in Table 6.7.16. In case of reinforced brickwork, the thickness of joints containing steel bars shall be increased so as to have a minimum mortar cover of 6 mm around the bar. In bands of reinforced brickwork, the area of steel provided shall be equal to that specified above for reinforced concrete bands.

Table 6.7.16: Band Reinforcement

Seismic Zones	Plain Mild Steel Bars	High Strength Deformed Bars	Links
2, 3	2 - 12 mm dia, one on each face of the wall with suitable cover	2 - 10 mm dia, one on each face of the wall with suitable cover	6 mm dia, 150 mm c/c
4	2 - 16 mm dia, one on each face of the wall with suitable cover	2 - 12 mm dia, one on each face of the wall with suitable cover	6 mm dia, 150 mm c/c

7.8.6.4 Strengthening of corner and junctions

Vertical steel at corners and junctions of walls which are up to one and a half bricks thick shall be provided either with mild steel or high strength deformed bars as specified in Table 6.7.17. For thicker walls, reinforcement shall be increased proportionately. The reinforcement shall be properly embedded in the plinth masonry of foundations and roof slab or roof band so as to develop its tensile strength in bond and passing through the lintel bands in all storeys. Bars in different storeys may be welded or suitably lapped.

- (a) Typical details of vertical steel in brickwork and hollow block at corners, T-junctions and jambs of opening are shown in Figures 6.7.1 and 6.7.2.
- (b) Details of vertical reinforcement given in Table 6.7.17 are applicable to brick masonry and hollow block masonry.

7.8.6.5 Strengthening of jambs of openings

Openings in bearing walls shall be strengthened, where necessary, by providing reinforced concrete members or reinforcing the brickwork around them as shown in Figure 6.7.3.

7.8.6.6 Walls adjoining structural framing

Where walls are dependent on the structural frame for lateral support they shall be anchored to the structural members with metal ties or keyed to the structural members. Horizontal ties shall consist of 6 mm diameter U-bars spaced at a maximum of 450 mm on centre and embedded at least 250 mm into the masonry and properly tied to the vertical steel of the same member.

Table 6.7.17: Vertical Reinforcement for Brick and Hollow Block Masonry

No. of Storeys	Storeys	Diameter of Single Bar or Equivalent Area of Plain Mild Steel Bar to be Provided (mm)		Diameter of Single Bar or Equivalent Area of High Strength Deformed Bar to be Provided (mm)	
		Zone 2 and 3	Zone 4	Zone 2 and 3	Zone 4
1	-	nil	12	nil	10
2	Top	nil	12	nil	10
	Bottom	nil	16	nil	12
3	Top	12	12	10	10
	Middle	12	16	10	12
	Bottom	16	16	12	12
4	Top	12	12	10	10
	Third	12	16	10	12
	Second	16	20	12	16
	Bottom	16	25	12	20

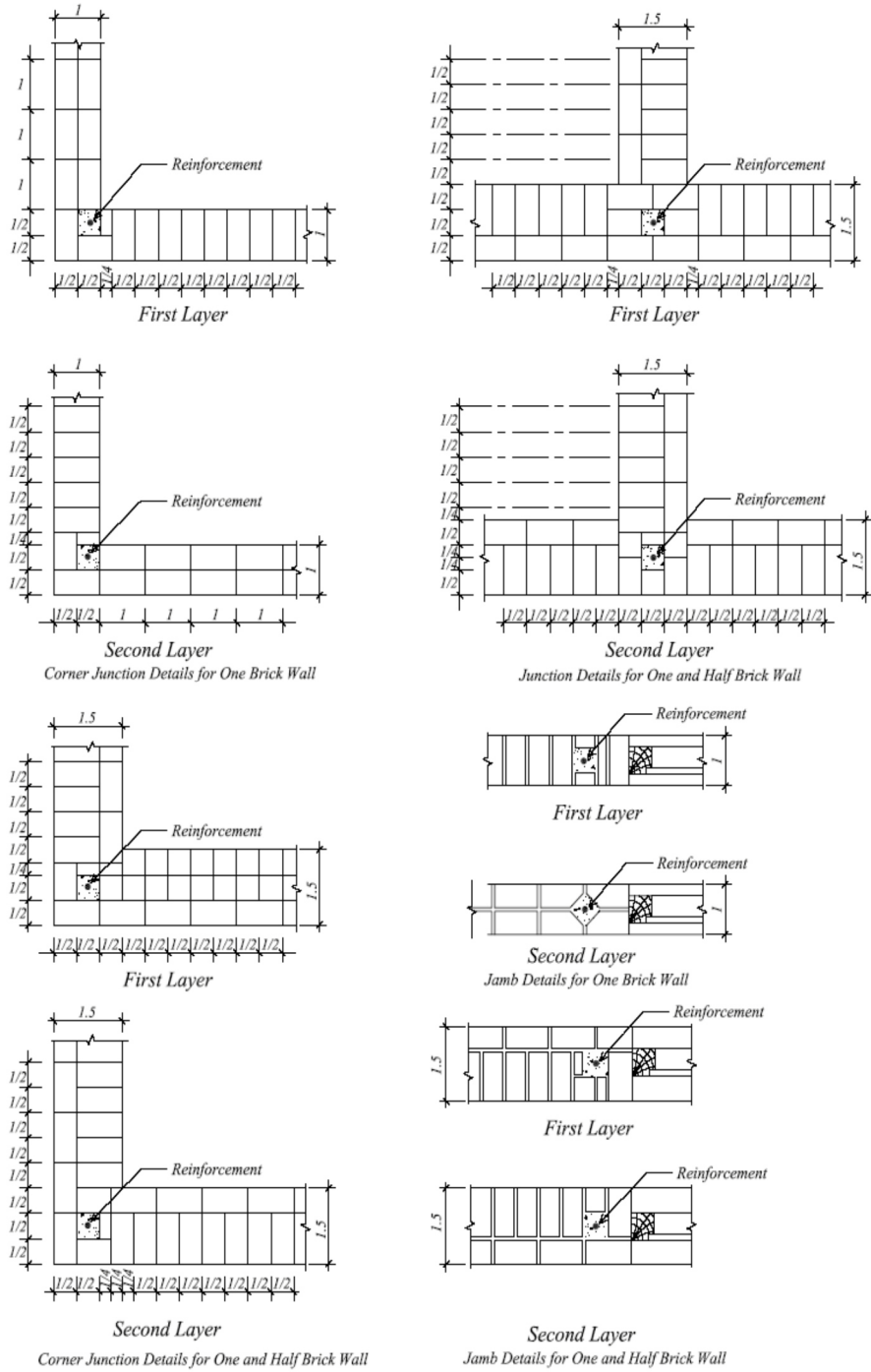


Figure 6.7.1 Typical details of vertical reinforcement in brick masonry

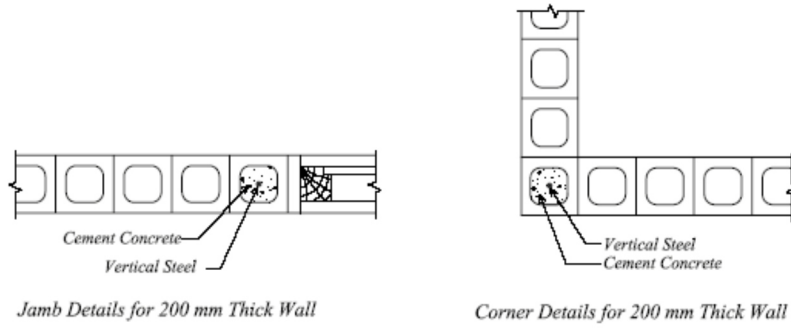


Figure 6.7.2 Typical details of vertical reinforcement in hollow block masonry

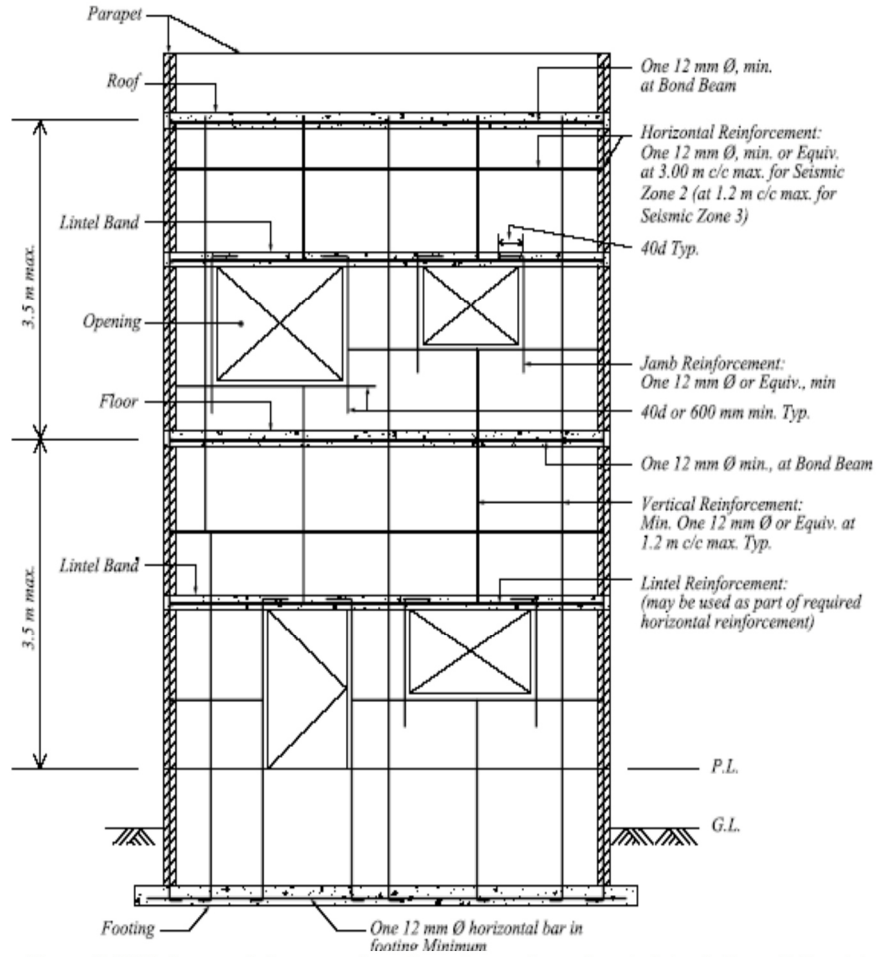


Figure 6.7.3 Minimum reinforcement in walls and around openings in Seismic Zones 2, 3 and 4

7.9 Provisions For High Wind Regions

7.9.1 General

The provisions of this Section shall apply to masonry structures located at regions where the basic wind speed is greater than 200 km/h.

7.9.2 Materials

Materials for masonry structures shall generally comply with the provisions of Part 5; however, there are some special requirements for masonry construction in high wind regions, which are given below:

- (a) Burnt clay bricks shall have a compressive strength not less than 15 N/mm²,
- (b) Grout shall have a minimum compressive strength of 12.5 N/mm²,
- (c) Mortar for exterior walls and interior shear walls shall be type M₁ or M₂,
- (d) Unburnt clay masonry units shall not be used.

7.9.3 Construction Requirements

Masonry construction shall comply with the provisions of Sec 7.10.

7.9.4 Foundation

Footings shall have a thickness of not less than 375 mm and shall be extended 450 mm below the undisturbed ground surface. Foundation stem wall shall have the same width and reinforcement as the wall it supports.

7.9.5 Drainage

Walls retaining more than 1 m of earth and enclosing interior spaces or floors below grade shall have minimum 100 mm diameter footing drain. A slope of 1:50 away from the building shall be provided around the building.

7.9.6 Wall Construction

7.9.6.1 Minimum thickness of different types of wall shall be as given in Table 6.7.18.

7.9.6.2 All walls shall be laterally supported at the top and bottom. The maximum unsupported height of bearing walls or other masonry walls shall be 3.5 m. Gable end walls may be 4.5 m high at their peak.

7.9.6.3 The span of lintels over openings shall not exceed 3.5 m. All lintels shall be reinforced and the reinforcement bars shall extend not less than 600 mm beyond the edge of opening and into lintel supports.

7.9.6.4 Walls shall be adequately reinforced.

7.9.6.5 Anchors between walls and floors or roofs shall be embedded in grouted cells or cavities and shall conform to Sec 7.9.7 below.

Table 6.7.18: Minimum thickness of Walls in High Wind Region

Type of Wall	Minimum Thickness (mm)
Unreinforced grouted brick wall	250
Reinforced exterior bearing wall	200
Unreinforced hollow and solid masonry wall	200
Interior nonbearing wall	150

7.9.7 Floor and Roof Systems

Floors and roofs of all masonry structures shall be adequately anchored with the wall it supports to resist lateral and uplift forces due to wind specified in Sec 2.4 of this Part.

7.9.8 Lateral Force Resistance

7.9.8.1 Strapping, approved framing anchors and mechanical fasteners, bond beams and vertical reinforcement shall be installed to provide a continuous tie from the roof to foundation system as shown in Figure 6.7.4. In addition, roof and floor systems, masonry shear walls, or masonry or wood cross walls shall be provided for lateral stability.

7.9.8.2 Floor and roof diaphragms shall be properly connected to masonry walls. Gable and sloped roof members not supported at the ridge shall be tied by the ceiling joist or equivalent lateral ties located as close to where the roof members bear on the wall as practically possible and not at more than 1.2 m on centers. Collar ties shall not be used for these lateral ties.

7.9.8.3 Masonry walls shall be provided around all sides of floor and roof systems in accordance with Figure 6.7.5. The cumulative length of exterior masonry walls along each side of the floor or roof systems shall be at least 20 percent of the parallel dimension. Required elements shall be without openings and shall not be less than 1.25 m in width.

Interior cross walls at right angles to bearing walls shall be provided when the length of the building perpendicular to the span of the floor or roof framing exceeds twice the distance between shear walls or 10 m, whichever is greater.

7.9.8.4 When required interior cross wall shall be at least 1.8 m long and reinforced with 2 mm wire joint reinforcement spaced not more than 400 mm on centre.

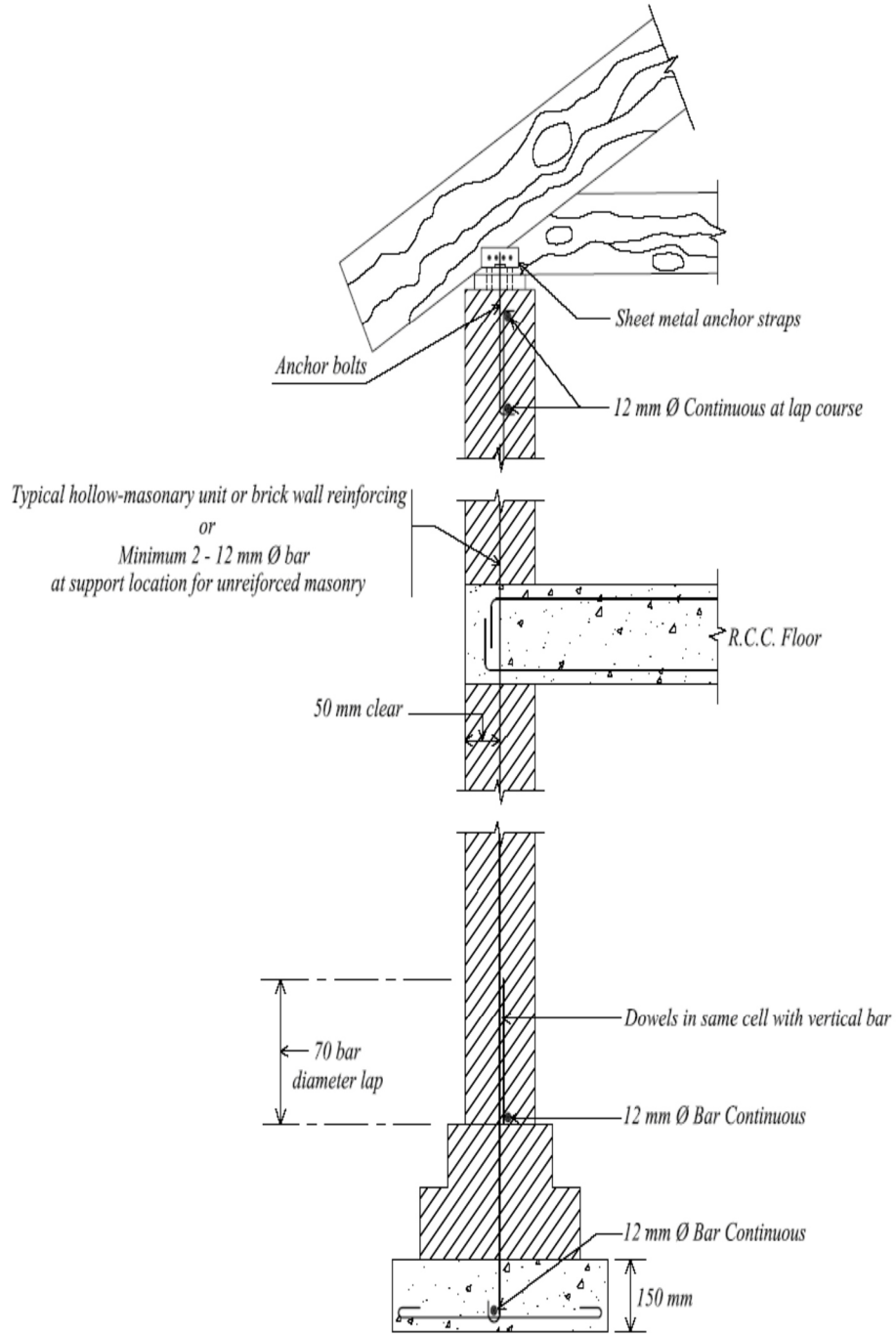


Figure 6.7.4 Continuous tie from roof to foundation of masonry structure

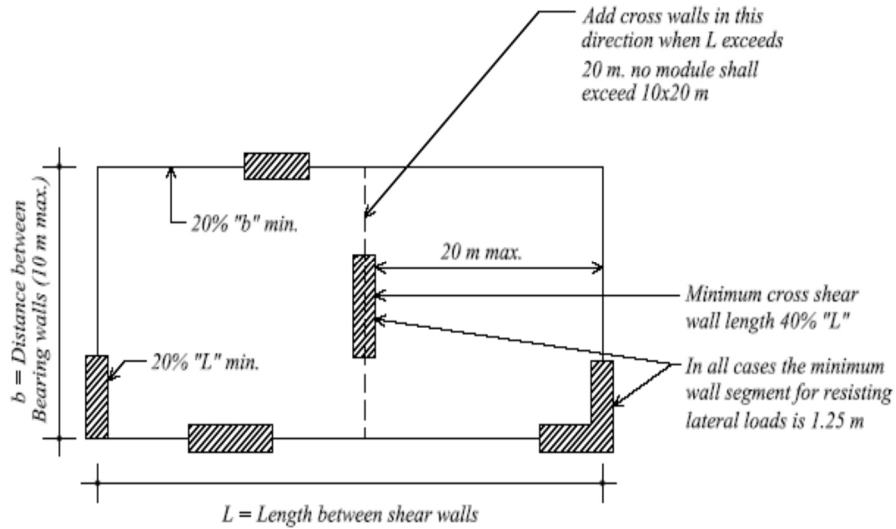


Figure 6.7.5 Masonry walls required in high wind regions

7.10 Construction

7.10.1 General

Masonry shall be constructed according to the provisions of this Section.

7.10.2 Storage and Preparation of Construction Materials

Storage, handling and preparation at the site shall conform to the following:

- (a) Masonry materials shall be stored in such a way that at the time of use the materials are clean and structurally suitable for the intended use.
- (b) All metal reinforcement shall be free from loose rust and other coatings that inhibit reinforcing bond.
- (c) Burnt clay units shall have a rate of absorption per minute not exceeding 1 litre/m² at the time of lying. In the absorption test the surface of the unit shall be held 3 mm below the surface of the water.
- (d) Burnt clay units shall be thoroughly wetted before placing. Concrete masonry units shall not be wetted unless otherwise approved.
- (e) Materials shall be stored in such a manner that deterioration or intrusion of foreign materials is prevented and at the time of mixing the material conforms to the applicable requirements.
- (f) The method of measuring materials for mortar and grout shall be such that proportions of the materials can be easily controlled.

- (g) Mortar or grout mixed at the job site shall be mixed for a period of time not less than 3 minutes or more than 10 minutes in a mechanical mixer with the amount of water required to provide the desired workability. Hand mixing of small amounts of mortar is permitted. Mortar may be retempered. Mortar or grout which has hardened or stiffened due to hydration of the cement shall not be used, but under no case shall mortar be used two and one-half hours, nor grout used one and one-half hours, after the initial mixing water has been added to the dry ingredients at the job site.

7.10.3 Placing Masonry Units

- (a) The mortar shall be sufficiently plastic and units shall be placed with sufficient pressure to extrude mortar from the joint and produce a tight joint. Deep furrowing which produces voids shall not be used.

The initial bed joint thickness shall not be less than 5 mm or more than 25 mm; subsequent bed joints shall be not less than 5 mm or more than 15 mm in thickness.

- (b) All surfaces in contact with mortar or grout shall be clean and free of deleterious materials.
- (c) Solid masonry units shall have full head and bed joints.
- (d) All head and bed joints shall be filled solidly with mortar for a distance from the face of the unit not less than the thickness of the shell. Head joints of open-end units with beveled ends need not be mortared. The beveled ends shall form a grout key which permits grout within 16 mm of the face of the unit. The units shall be tightly butted to prevent leakage of grout.

7.10.4 Verticality and Alignment

All masonry shall be built true and plumb within the tolerances prescribed below. Care shall be taken to keep the perpend properly aligned.

- (a) Deviation from vertical within a storey shall not exceed 6 mm per 3m height.
- (b) Deviation in verticality in total height of any wall of a building more than one storey in height shall not exceed 12 mm.
- (c) Deviation from position shown on plan of any brickwork shall not exceed 12 mm.
- (d) Relative displacement between load bearing walls in adjacent storeys intended to be in vertical alignment shall not exceed 6 mm.
- (e) Deviation of bed joint from horizontal in a length of 12 m shall not exceed 6 mm subject to a maximum deviation of 12 mm.
- (f) Deviation from the specified thickness of bed joints, cross joints and perpend shall not exceed one-fifth of the specified thickness.

7.10.5 Reinforcement Placing

Reinforcing details shall conform to the requirements of Sec 7.6.6. Metal reinforcement shall be located in accordance with the plans and specifications. Reinforcement shall be secured against displacement prior to grouting by wire positioners or other suitable devices at intervals not exceeding 20 bar diameters.

Tolerances for the placement of steel in walls and flexural elements shall be ± 12 mm for $d \leq 200$ mm, ± 25 mm for $200 \text{ mm} \leq d \leq 600$ mm and ± 30 mm for $d > 600$ mm. Tolerance for longitudinal location of reinforcement shall be ± 50 mm.

7.10.6 Grouted Masonry

Grouted masonry shall be constructed in such a manner that all elements act together as a structural element.

Space to be filled with grout shall be clean and shall not contain any foreign materials. Grout materials and water content shall be controlled to provide adequate workability and shall be mixed thoroughly. The grouting of any section of wall shall be completed in one day with no interruptions greater than one hour.

Size and height limitations of the grout space or cell shall not be less than those shown in Table 6.7.19. Higher grout pours or smaller cavity widths or cell size than shown in Table 6.7.19 may be used when approved, if it can be demonstrated that grout spaces are properly filled.

Cleanouts are required for all grout pours over 1.5 m in height. When required, cleanouts shall be provided in the bottom course at every vertical bar but shall not be spaced more than 800 mm on centre for solidly grouted masonry. When cleanouts are required, they shall be sealed after inspection and before grouting. When cleanouts are not provided, special provisions must be made to keep the bottom and sides of the grout spaces, as well as the minimum total clear area as required by Table 6.7.19, clean and clear prior to grouting.

Table 6.7.19: Grouting Limitations

Grout Type	Grout pour Maximum Height (m)	Minimum Dimensions of the Total Clear Areas within Grout Spaces and Cells	
		Multi-wythe Masonry (mm)	Hollow Unit Masonry (mm)
Fine	0.30	20	40 × 50
	1.50	40	40 × 50
	2.40	40	40 × 75
	3.65	40	45 × 75
	7.30	50	75 × 75
Coarse	0.30	40	40 × 75
	1.50	50	60 × 75
	2.40	50	75 × 75
	3.65	60	75 × 75
	7.30	75	75 × 100

7.10.7 Chases, Recesses and Holes

- (a) Chases, recesses and holes may be permitted in masonry provided either they are considered in the structural design or they are not cut into walls made of hollow or perforated units, or vertical chases are planned instead of horizontal chases.
- (b) Depth of vertical and horizontal chases in load bearing walls shall not exceed one-third and one-sixth of the wall thickness respectively.
- (c) Vertical chases shall not be closer than 2 m in any stretch of wall and shall not be located within 350 mm of an opening or within 230 mm of a cross wall that serves as stiffening wall for stability. Width of a vertical chase shall not exceed the thickness of wall in which it occurs.
- (d) Horizontal chases shall be located in the upper or lower middle third height of wall at a distance not less than 600 mm from lateral support. No horizontal chase shall exceed one metre in length and there shall not be more than 2 chases in any one wall. Horizontal chases shall have minimum mutual separation distance of 500 mm. Sum of lengths of all chases and recesses in any horizontal plane shall not exceed one-fourth the length of the wall.
- (e) Lintel shall not be used to support masonry directly above a recess or a hole wider than 300 mm. No lintel however, is necessary in case of a circular recess or hole exceeding 300 mm in diameter provided upper half of the recess or hole is built as a semi-circular arch of adequate thickness and there is adequate length of masonry on the sides of openings to resist the horizontal thrust.
- (f) Recesses and holes in masonry shall be kept at the time of construction so as to avoid subsequent cutting. If cutting is necessary, it shall be done using sharp tools without causing heavy impact and damage to the surrounding areas.
- (g) No chase, recess or hole shall be provided in half-brick load bearing wall, excepting the minimum number of holes needed for scaffolding.

7.11 Confined Masonry

7.11.1 General

Confined masonry construction consists of masonry walls (made either of clay brick or concrete block units) and horizontal and vertical RC confining members built on all four sides of a masonry wall panel. Vertical members, called tie-columns or practical columns, resemble columns in RC frame construction except that they tend to be of far smaller cross-section. Horizontal elements, called tie-beams, resemble beams in RC frame construction. To emphasize that confining elements are not beams and columns, alternative terms horizontal ties and vertical ties could be used instead of tie-beams and tie-columns.

The confining members are effective in

- (a) Enhancing the stability and integrity of masonry walls for in-plane and out-of-plane earthquake loads (confining members can effectively contain damaged masonry walls),
- (b) Enhancing the strength (resistance) of masonry walls under lateral earthquake loads, and
- (c) Reducing the brittleness of masonry walls under earthquake loads and hence improving their earthquake performance.

The structural components of a confined masonry building are (see Figure 6.7.6):

- (a) Masonry walls - transmit the gravity load from the slab(s) above down to the foundation. The walls act as bracing panels, which resist horizontal earthquake forces. The walls must be confined by concrete tie-beams and tie-columns to ensure satisfactory earthquake performance.
- (b) Confining elements (tie-columns and tie-beams) - provide restraint to masonry walls and protect them from complete disintegration even in major earthquakes.

These elements resist gravity loads and have important role in ensuring vertical stability of a building in an earthquake.

- (a) Floor and roof slabs - transmit both gravity and lateral loads to the walls. In an earthquake, slabs behave like horizontal beams and are called diaphragms.
- (b) Plinth band - transmits the load from the walls down to the foundation. It also protects the ground floor walls from excessive settlement in soft soil conditions.
- (c) Foundation - transmits the loads from the structure to the ground.

The design of confined masonry members shall be based on similar assumptions to those set out for unreinforced and for reinforced masonry members. Confined masonry shall be constructed according to the provisions of this Section.

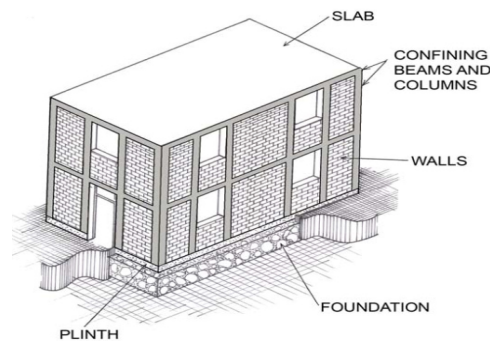


Figure 6.7.6 Typical confined masonry building

7.11.2 Difference of Confined Masonry from RC Frame Construction

The appearance of a finished confined masonry construction and a RC frame construction with masonry in fills may look alike, however these two construction systems are substantially different. The main differences are related to the construction sequence, as well as to the manner in which these structures resist gravity and lateral loads. These differences are summarized in Table 6.7.20 and are illustrated by diagrams in Figure 6.7.7.

In confined masonry construction, confining elements are not designed to act as a moment-resisting frame; as a result, detailing of reinforcement is simple. In general, confining elements have smaller cross-sectional dimensions than the corresponding beams and columns in a RC frame building. It should be noted that the most important difference between the confined masonry walls and infill walls is that infill walls are not load-bearing walls, while the walls in a confined masonry building are.

A transition from RC frame to confined masonry construction in most cases leads to savings related to concrete cost, since confining elements are smaller in size than the corresponding RC frame members.

Table 6.7.20: Comparison between confined masonry and RC frame construction

Component	Confined masonry construction	RC frame construction
Gravity and lateral load-resisting system	Masonry walls are the main load bearing elements and are expected to resist both gravity and lateral loads. Confining elements (tie-beams and tie-columns) are significantly smaller in size than RC beams and columns.	RC frames resist both gravity and lateral loads through their relatively large beams, columns, and their connections. Masonry in fills are not load-bearing walls.
Foundation construction	Strip footing beneath the wall and the RC plinth band	Isolated footing beneath each column
Superstructure construction sequence	<ol style="list-style-type: none"> 1. Masonry walls are constructed first. 2. Subsequently, tie-columns are cast in place. 3. Finally, tie-beams are constructed on top of the walls, simultaneously with the floor/roof slab construction. 	<ol style="list-style-type: none"> 1. The frame is constructed first. 2. Masonry walls are constructed at a later stage and are not bonded to the frame members; these walls are nonstructural, that is, non-load bearing walls.

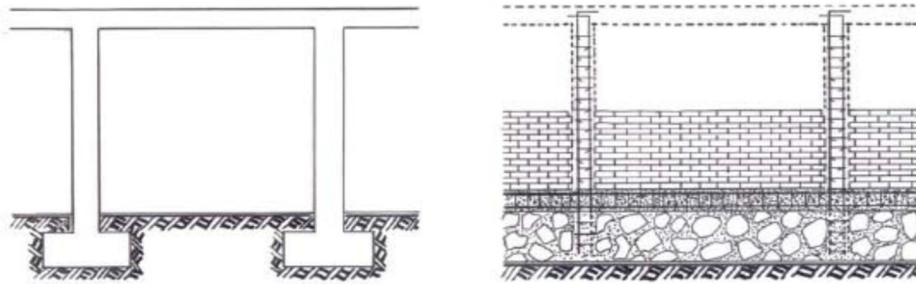
7.11.3 Mechanism of Resisting Earthquake Effects

A confined masonry building subjected to earthquake ground shaking can be modeled as a vertical truss, as shown in Figure 6.7.8. Masonry walls act as diagonal struts subjected to compression, while reinforced concrete confining members act in tension and/or compression, depending on the direction of lateral earthquake forces. This model is appropriate before the cracking in the walls takes place. Subsequently, the cracking is concentrated at the ground floor level and significant lateral deformations take place. Under severe earthquake ground shaking, the collapse of confined masonry buildings may take place due to soft storey effect similar to the one observed in RC frames with masonry in fills, as shown in Figure 6.7.8. The following failure modes are characteristic of confined masonry walls:

- (a) Shear failure mode, and; (b) Flexural failure mode.

Note that, in confined masonry structures, shear failure mode develops due to in-plane seismic loads (acting along in the plane of the wall), whereas flexural failure mode may develop either due to in-plane or out-of-plane loads (acting perpendicular to the wall plane).

Shear failure mode is characterized by distributed diagonal cracking in the wall. These cracks propagate into the tie-columns at higher load levels, as shown in Figure 6.7.9. Initially, a masonry wall panel resists the effects of lateral earthquake loads by itself while the confining elements (tie-columns) do not play a significant role. However, once the cracking takes place, the wall pushes the tie-columns sideways. At that stage, vertical reinforcement in tie-columns becomes engaged in resisting tension and compression stresses. Damage in the tie-columns at the ultimate load level is concentrated at the top and the bottom of the panel. These locations, characterized by extensive crushing of concrete and yielding of steel reinforcement, are called plastic hinges (Figure 6.7.10). Note that the term plastic hinge has a different meaning in the context of confined masonry components than that referred to in relation to RC beams and columns, where these hinges form due to flexure and axial loads. In confined masonry construction, tie-beams and tie-columns resist axial loads. Shear failure can lead to severe damage in the masonry wall and the top and bottom of the tie-columns.



(a)

(b)

Figure 6.7.7 (a) RC frame construction; (b) Confined masonry construction

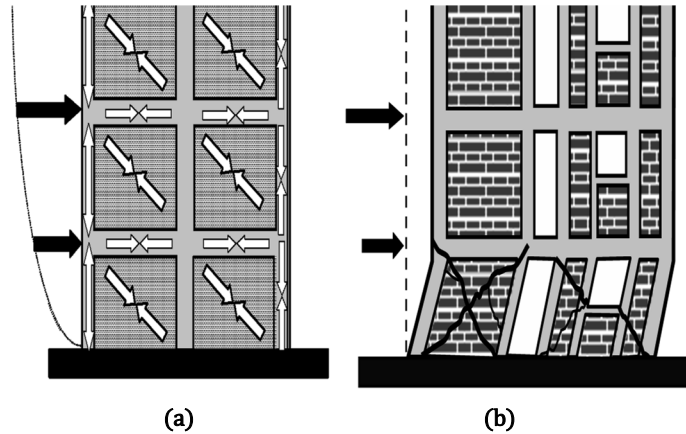


Figure 6.7.8 Confined masonry building: (a) Vertical truss model; (b) Collapse at the ground floor level

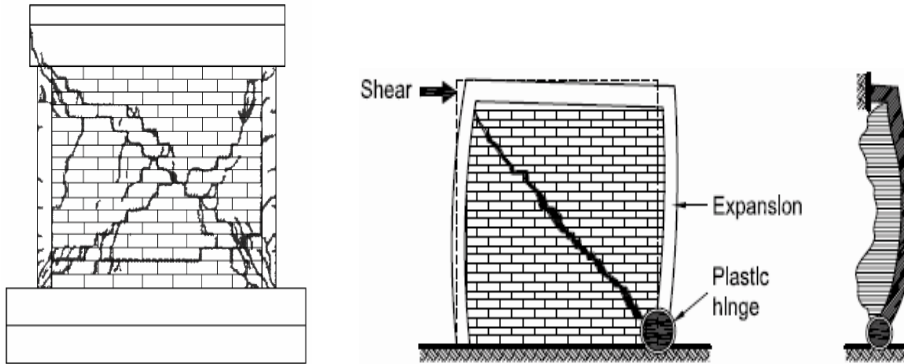


Figure 6.7.9 Shear failure of confined masonry walls Figure 6.7.10 Plastic hinge developed in a confined masonry wall

Flexural failure caused by in-plane lateral loads is characterized by horizontal cracking in the mortar bed joints on the tension side of the wall, as shown in Figure 6.7.11. Extensive horizontal cracking, which usually takes place in tie-columns, as well as shear cracking can be observed.

Irrespective of the failure mechanism, tie-columns resist the major portion of gravity load when masonry walls suffer severe damage (this is due to their high axial stiffness and load resistance). The failure of a tie-column usually takes place when cracks propagate from the masonry wall into the tie-column and shear it off. Subsequently, the vertical stability of the entire wall is compromised. Vertical strains in the confined masonry walls decrease at an increased damage level, thereby indicating that a major portion of the gravity load is resisted by tie-columns. This finding confirms the notion that tie-columns have a critical role in resisting the gravity load in damaged confined masonry buildings and ensuring their vertical stability.

7.11.4 Key Factors Influencing Seismic Resistance

7.11.4.1 Wall density

Wall density is believed to be one of the key parameters influencing the seismic performance of confined masonry buildings. It can be determined as the transverse area of walls in each principal direction divided by the total floor area of the building.

7.11.4.2 Masonry units and mortar

The lateral load resistance of confined masonry walls strongly depends on the strength of the masonry units and the mortar used. The walls built using low-strength bricks or ungrouted hollow block units had the lowest strength while the ones built using grouted or solid units had the largest strength. However, the use of grouted and solid units results in an increase both in wall mass and seismic loads. Also, the weaker the mortar the lower the masonry strength (due to the unit-mortar interaction, the masonry strength is always lower than the unit strength). There is no significant difference in strength between unreinforced and confined masonry wall specimens with the same geometry and material properties.

7.11.4.3 Tie-columns

Tie-columns significantly influence the ductility and stability of cracked confined masonry walls. The provision of closely spaced transverse reinforcement (ties) at the top and bottom ends of tie-columns results in improved wall stability and ductility in the post-cracking stage.

7.11.4.4 Horizontal wall reinforcement

Horizontal reinforcement has a beneficial effect on wall ductility. Specimens with horizontal reinforcement showed a more uniform distribution of inclined shear cracks than the unreinforced specimens. Horizontal rebars should be anchored into the tie-columns; the anchorage should be provided with 90° hooks at the far end of the tie-column (Figure 6.7.12). The hooks should be embedded in the concrete within the tie-column (note that the tie-column reinforcement was omitted from the figure). The bar diameter should be larger than 3.5 mm and less than $\frac{3}{4}$ the joint thickness.

7.11.4.5 Openings

When the opening area is less than approximately 10 percent of the total wall area, the wall lateral load resistance is not significantly reduced as compared to a solid wall (i.e. wall without openings). The walls with larger openings develop diagonal cracks (same as solid walls), except that the cracks are formed in the piers between the openings; thus, diagonal struts form in the piers, as shown in Figure 6.7.13.

7.11.5 Verification of Members

7.11.5.1 In the verification of confined masonry members subjected to bending and/or axial loading, the assumptions for reinforced masonry members should be adopted. In determining the design value of the moment of resistance of a section a rectangular stress distribution may be assumed, based on the strength of the masonry, only. Reinforcement in compression should also be ignored.

7.11.5.2 In the verification of confined masonry members subjected to shear loading the shear resistance of the member should be taken as the sum of the shear resistance of the masonry and of the concrete of the confining elements. In calculating the shear resistance of the masonry the rules for unreinforced masonry walls subjected to shear loading should be used, considering the length of the masonry element. Reinforcement of confining elements should not be taken into account.

7.11.5.3 In the verification of confined masonry members subjected to lateral loading, the assumptions set out for unreinforced and reinforced masonry walls should be used. The contribution of the reinforcement of the confining elements should be considered.

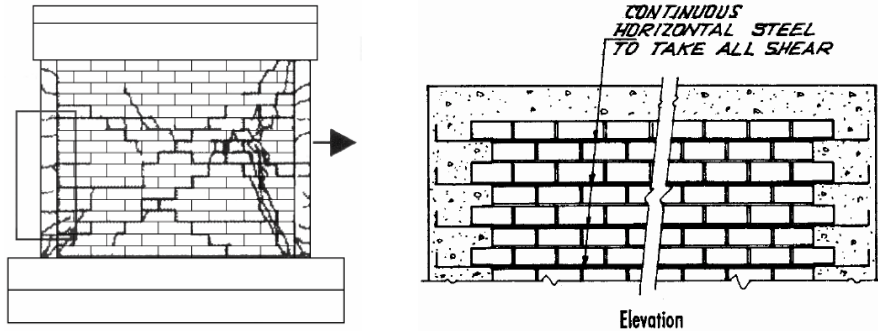


Figure 6.7.11 Flexural failure of confined masonry walls

Figure 6.7.12 Horizontal reinforcement in confined masonry walls

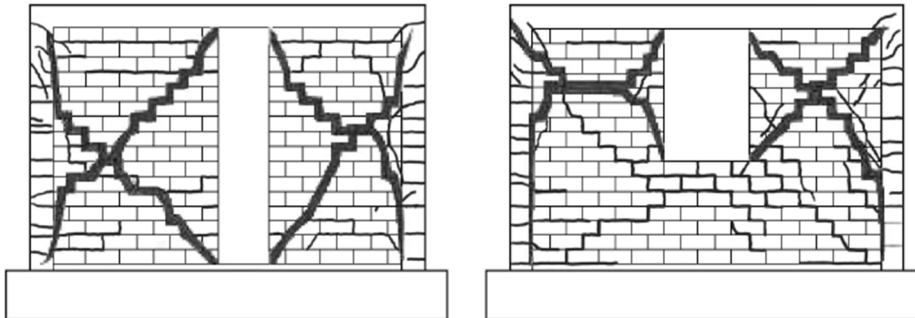


Figure 6.7.13 Failure modes in the confined masonry walls with openings

7.11.6 Confined Masonry Members

7.11.6.1 Confined masonry members shall not exhibit flexural cracking nor deflect excessively under serviceability loading conditions.

7.11.6.2 The verification of confined masonry members at the serviceability limit states shall be based on the assumptions given for unreinforced masonry members.

7.11.7 Architectural Guideline**7.11.7.1 Building Layout**

- (a) The building should not be excessively long relative to its width; ideally, the length-to-width ratio should not exceed 4.
- (b) The walls should be continuous up the building height.
- (c) Openings (doors and windows) should be placed in the same position up the building height.

7.11.7.2 Walls

- (a) At least two fully confined walls should be provided in each direction.
- (b) For Seismic Zone 1 and 2, wall density of at least 2 percent in each of two orthogonal directions is required to ensure good earthquake performance of confined masonry construction. The wall density for Seismic Zones 3 and 4 should be at least 4 percent and 5 percent respectively. Wall density can be defined as the total cross sectional area of all walls in one direction divided by the sum of the floor plan areas for all floors in a building.

7.11.7.3 Building Height

Confined masonry is suitable for low- to medium-rise building construction. Confined masonry buildings will be subject to the following height restrictions:

- (a) Up to 4-storey high for Seismic Zone 1 and 2
- (b) Up to 3-storey high for Seismic Zone 3
- (c) Up to 2-storey high for Seismic Zone 4

7.11.8 Confined Masonry Details

7.11.8.1 Confined masonry walls shall be provided with vertical and horizontal reinforced concrete or reinforced masonry confining elements so that they act together as a single structural member.

7.11.8.2 Top and sides confining elements shall be cast after the masonry has been built so that they will be duly anchored together.

7.11.8.3 Vertical confining elements should be placed:

- (a) at the free edges of each structural wall element;
- (b) at both sides of any wall opening with an area of more than 1.5 m²;
- (c) within the wall if necessary in order not to exceed a spacing of 5 m between the confining elements;
- (d) at the intersections of structural walls, wherever the confining elements imposed by the above rules are at a distance larger than 1.5 m.

7.11.8.4 Horizontal confining elements shall be placed in the plane of the wall at every floor level and in any case with a vertical spacing of not more than 4 m.

7.11.8.5 Confining elements should have a cross-sectional area not less than 0.02 m², with a minimum dimension of 150 mm in the plan of the wall. In double-leaf walls the thickness of confining elements should assure the connection of the two leaves and their effective confinement.

7.11.8.6 The longitudinal reinforcement of confining elements may not have a cross-sectional area less than 300 mm², nor than 1 percent of the cross-sectional area of the confining element. The detailing of the reinforcements should be in accordance with Chapter 8.

7.11.8.7 Stirrups not less than 6 mm in diameter and spaced not more than 300 mm should be provided around the longitudinal reinforcement. Column ties should preferably have 135° hooks – the use of 90° hooks is not recommended. At a minimum, 6 mm ties at 200 mm spacing (6 mm@200 mm) should be provided. It is recommended to use 6 mm ties at 100 mm spacing (6 mm@100 mm) in the column end-zones (top and bottom).

7.11.8.8 To ensure the effectiveness of tie-beams in resisting earthquake loads, longitudinal bars should have a 90° hooked anchorage at intersections, as shown in Figure 6.7.14. The hook length should be at least 500 mm.

7.11.8.9 Proper detailing of the tie-beam-to-tie-column connections is a must for satisfactory earthquake performance of the entire building. Reinforcing bars must be properly anchored. A typical connection detail at the roof level is shown in Figure 6.7.15. Note that the tie-column reinforcement needs to be extended into the tie-beam as much as possible, preferably up to the underside of the top tie-beam reinforcement. A hooked anchorage needs to be provided (90° hooks) both for the tie-column and tie-beam reinforcement.

7.11.8.10 Special lintel beams may be required across larger openings having a width exceeding 1.5 m. Additional reinforcement bars need to be provided. Lintel beams can be integrated with the tie-beams at the floor level.

7.11.8.11 Lap splices may not be less than 60 bar diameters or 500 mm in length. Splicing should take place at column mid height, except for the ground floor level (where splicing is not permitted).

7.11.8.12 The minimum wall thickness should not be less than 100 mm. The wall height/thickness ratio should not exceed 30.

7.11.8.13 Toothed edges should be left on each side of the wall, as shown in Figure 6.7.16(a). Toothed edges are essential for adequate wall confinement, which contributes to satisfactory earthquake performance. Alternatively, when the interface between the masonry wall and the concrete tie-column needs to remain smooth for appearance's sake, steel dowels should be provided in mortar bed joints to ensure interaction between the masonry and the concrete during an earthquake, Figure 6.7.16(b).

7.11.8.14 Concrete in the tie-columns can be poured once the desired wall height has been reached. The masonry walls provide formwork for the tie-columns on two sides; however the formwork must be placed on the remaining two sides.

7.11.9 Foundation and Plinth Construction

The foundation should be constructed as in traditional brick masonry construction. Either an uncoursed random rubble stone masonry footing or a RC strip footing can be used. A RC plinth band should be constructed on top of the foundation. In confined masonry construction, plinth band is essential for preventing building settlements in soft soil areas. An alternative foundation solution with RC strip footing is also illustrated in Figure 6.7.17.

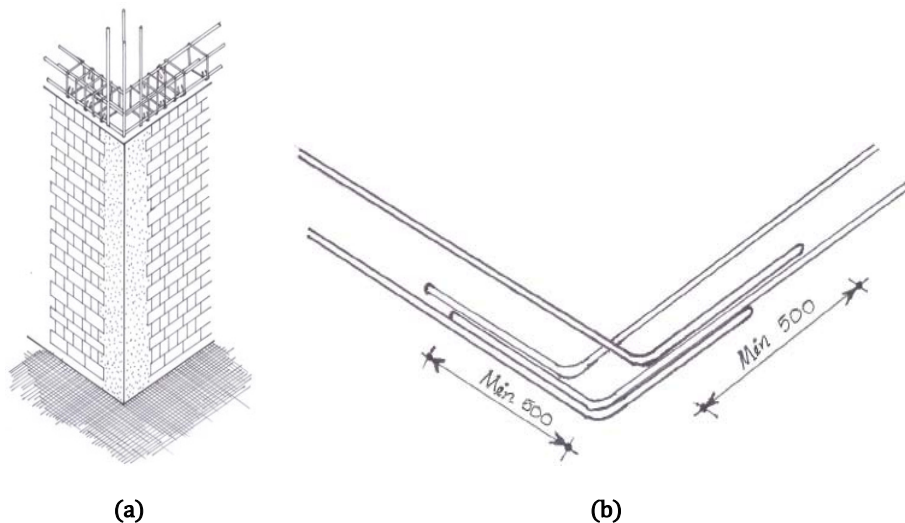


Figure 6.7.14 Tie-beam construction: (a) Wall intersections; (b) Hooked anchorage to longitudinal reinforcement

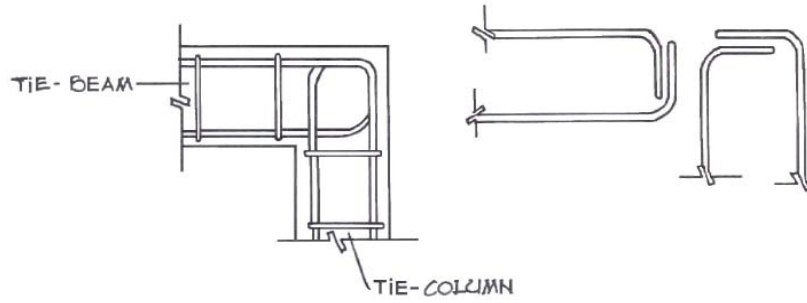


Figure 6.7.15: Detailing requirement for the tie-beam-to-tie-column connection

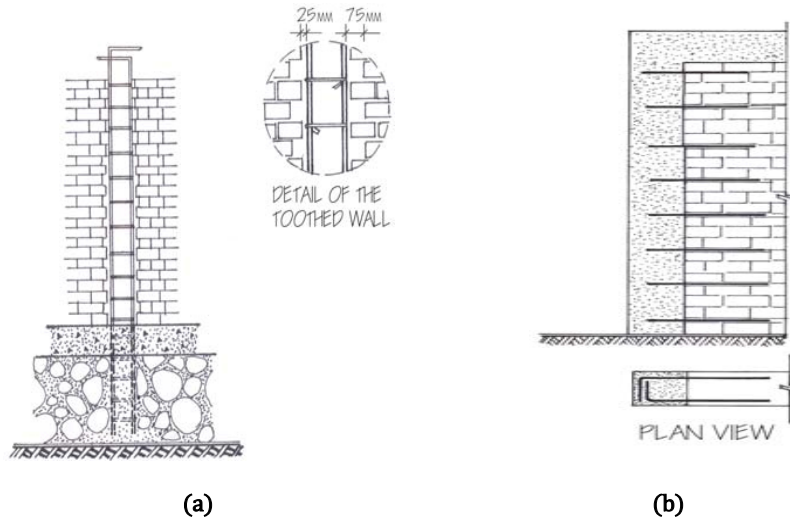


Figure 6.7.16 (a) Toothed wall construction; (b) Horizontal dowels at the wall-to-column interface

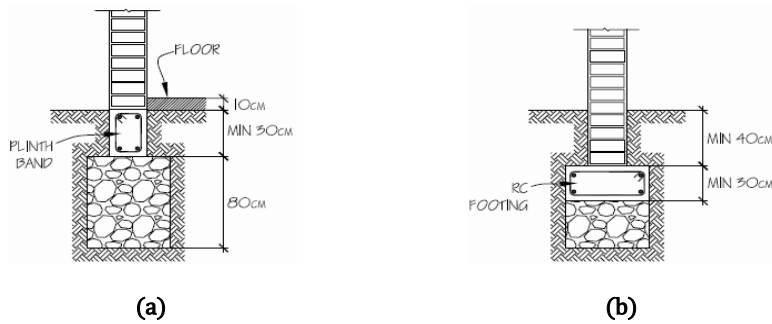


Figure 6.7.17 Foundation construction: (a) RC plinth band and stone masonry foundation; (b) RC strip footing

PART VI
Chapter 8
Detailing of Reinforcement in Concrete Structures

8.1 Introduction

Provisions of Sections 8.1 and 8.2 of Chapter 8 shall apply for detailing of reinforcement in reinforced concrete members, in general. For reinforced concrete structures, subject to earthquake loadings in seismic design categories B, C and D, special provisions contained in Sec 8.3 of this Chapter shall apply. The definitions and notation provided in the following Sections are related to Sec 8.3. The definitions and notation used in other Sections, unless otherwise mentioned, are similar to those provided in Sections 6.1.1 and 6.1.2 Chapter 6.

8.1.1 Definitions and Notation

8.1.1.1 Definitions

BASE OF STRUCTURE	The level at which earthquake motions are assumed to be imparted to a structure. This level does not necessarily coincide with the ground level.
BOUNDARY MEMBERS	Members along wall and diaphragm edges strengthened by longitudinal and transverse reinforcement. These members do not necessarily require an increase in the thickness of the wall or diaphragm. If required, edges of openings within walls and diaphragms shall be provided with boundary members.
COLLECTOR ELEMENTS	Elements that are used to transmit the inertial forces within the diaphragms to members of the lateral force resisting systems.
CROSS TIE	A continuous bar having a hook not less than 135° with at least a six diameter extension at one end but not less than 75 mm, and a hook not less than 90° with at least a six diameter extension at the other end. The hooks shall engage peripheral longitudinal bars. The 90° hooks of two successive cross ties engaging the same longitudinal bars shall be alternated end for end.

DEVELOPMENT LENGTH OF A STANDARD HOOK	The shortest distance between the critical section and a tangent to the outer edge of the 90° hook.
HOOP	A hoop is a closed tie or continuously round tie. A closed tie can be made up of several reinforcing elements with 135° hooks having a six diameter extension at each end (but not less than 75 mm). A continuously round tie shall have at each end a 135° hook with a six diameter extension that engages the longitudinal reinforcement but not less than 75 mm.
LATERAL FORCE RESISTING SYSTEM	That portion of the structure composed of members designed to resist forces related to earthquake effects.
SHELL CONCRETE	Concrete outside the transverse reinforcement confining the concrete
STRUCTURAL DIAPHRAGMS	Structural members, such as floor and roof slabs, which transmit inertial forces to lateral force resisting members.
STRUCTURAL WALLS	Walls designed to resist combinations of shears, moments, and axial forces induced by earthquake motions. A shear wall is a structural wall.
STRUT	An element of a structural diaphragm used to provide continuity around an opening in the diaphragm.
TIE ELEMENTS	Elements used to transmit inertial forces and prevent separation of building components.

8.1.1.2 Notation

A_{ch}	=	Cross-sectional area of a structural member measured out to out of transverse reinforcement, mm ²
A_{cp}	=	Area of concrete section resisting shear of an individual pier or horizontal wall segment, mm ²
A_{cv}	=	Net area of concrete section bounded by web thickness and length of section in the direction of shear force considered, mm ²
A_g	=	Gross area of section, mm ²
A_j	=	Effective cross-sectional area within a joint, see Sec 8.3.7.3, in a plane parallel to plane of reinforcement generating shear in the joint. The joint depth shall be the overall depth of the column. Where a beam frames into a support of larger width, the effective width of the joint shall not exceed the smaller of : (a) Beam width plus the joint depth (b) twice the smaller perpendicular distance from the longitudinal axis of the beam to the column side (See Sec 8.3.7.3)

- A_{sh} = Total cross-sectional area of transverse reinforcement (including cross ties) within spacing s and perpendicular to dimension h_c
- E = Load effects of earthquake or related internal moments and forces
- M_{pr} = Probable flexural moment strength of members, with or without axial load, determined using the properties of the member at the joint faces assuming a tensile strength in the longitudinal bars of at least $1.25f_y$ and a strength reduction factor ϕ of 1.0, N-mm
- M_s = Portion of slab moment balanced by support moment
- V_c = Nominal shear strength provided by concrete, N
- V_e = Design shear force corresponding to the development of the probable moment strength of the member, N
- V_n = Nominal shear strength, N
- V_u = Factored shear force at section, N
- b = Effective compressive flange width of a structural member, mm
- b_w = Web width or diameter of circular section, mm
- d = Distance from extreme compression fibre to centroid of longitudinal tension reinforcement, mm
- d_b = Bar diameter, mm
- f'_c = Specified compressive strength of concrete, MPa
- f_y = Specified yield strength of reinforcement, MPa
- f_{yt} = Specified yield strength of transverse reinforcement, MPa
- h = Overall thickness or height of member, mm
- h_c = Cross-sectional dimension of column core measured to the outside edge of the transverse reinforcement composing area A_{sh} mm centre to centre of confining reinforcement
- h_w = Height of entire wall (diaphragm) or of the segment of wall (diaphragm) considered, mm
- h_x = Maximum centre to centre horizontal spacing of crossties or hoop legs on all faces of the column, mm
- l_d = Development length in tension of deformed bar, deformed wire, plain and deformed welded wire reinforcement, mm

- l_{dh} = Development length in tension of deformed bar or deformed wire with a standard hook, measured from critical section to outside end of hook [straight embedment length between critical section and start of hook (point of tangent) plus inside radius of bend and one bar diameter], mm
- l_o = Minimum length, measured from joint face along axis of structural member, over which special transverse reinforcement must be provided, mm
- l_w = Length of entire wall (diaphragm) or of segment of wall (diaphragm) considered in the direction of shear force, mm
- s = Spacing of transverse reinforcement measured along longitudinal axis of the structural member, mm
- s_o = Maximum spacing of transverse reinforcement, mm
- α_c = Coefficient defining the relative contribution of concrete strength to wall strength
- ρ = Ratio of tension reinforcement to member area = A_s/b_d
- ρ_g = Ratio of total reinforcement area to cross-sectional area of column
- ρ_n = Ratio of distributed shear reinforcement on a plane perpendicular to plane of A_{cv}
- ρ_s = Ratio of volume of spiral reinforcement to the core volume confined by the spiral reinforcement (measured out to out of spiral)
- ρ_v = A_{sv}/A_{cv} ; where A_{sv} is the projection on A_{cv} of area of distributed shear reinforcement crossing the plane of A_{cv}
- ϕ = Strength reduction factor.

8.1.2 Standard Hooks and Minimum Bend Diameters

8.1.2.1 Standard hooks

The term "standard hook" as used in this Code shall mean one of the following:

- 180° bend plus an extension of at least 4 bar diameters, but not less than 65 mm at the free end of the bar.
- 90° bend plus an extension of at least 12 bar diameters at the free end of the bar.

- (c) For stirrup and tie anchorage
- (i) For 16 mm diameter bar and smaller, a 90° bend plus an extension of at least 6 bar diameters at the free end of the bar,
 - (ii) For 19 mm to 25 mm diameter bars, a 90° bend plus an extension of at least 12 bar diameters at the free end of the bar,
 - (iii) For 25 mm diameter bar and smaller, a 135° bend plus an extension of at least 6 bar diameters at the free end of the bar,
 - (iv) For closed ties and continuously wound ties, a 135° bend plus an extension of at least 6 bar diameters, but not less than 75 mm.
- (d) Seismic hook is defined as a hook on a stirrup, hoop, or crosstie having a bend not less than 135°, except that circular hoops shall have a bend not less than 90°. Hooks shall have a six-diameter (but not less than 75 mm) extension that engages the longitudinal reinforcement and projects into the interior of the stirrup or hoop.

8.1.2.2 Minimum bend diameters

- (a) The minimum diameter of bend measured on the inside of the bar, for standard hooks other than for stirrups and ties in sizes of 10 mm to 16 mm diameter shall not be less than the values shown in Table 6.8.1.

Table 6.8.1: Minimum Diameters of Bend

Bar Size	Minimum Diameter of Bend
$10 \text{ mm} \leq d_b \leq 25 \text{ mm}$	$6d_b$
$25 \text{ mm} < d_b \leq 40 \text{ mm}$	$8d_b$
$40 \text{ mm} < d_b \leq 57 \text{ mm}$	$10d_b$

- (b) For stirrups and tie hooks, inside diameter of bend shall not be less than 4 bar diameters for 16 mm diameter bar and smaller. For bars larger than 16 mm diameter, bend diameter shall be in accordance with Table 6.8.1.
- (c) Inside diameter of bend in welded wire reinforcement for stirrups and ties shall not be less than 4 bar diameters for deformed wire larger than ASTM MD40 size (ASTM A1022) and 2 bar diameters for all other wires. Bends with inside diameter of less than 8 bar diameters shall not be less than 4 bar diameters from nearest welded intersection.

8.1.3 Bending

8.1.3.1 Unless otherwise permitted by the engineer, all reinforcement shall be bent cold.

8.1.3.2 Reinforcement partially embedded in concrete shall not be bent in place, except as permitted by the engineer or as shown in the design drawings.

8.1.4 Surface Conditions of Reinforcement

8.1.4.1 When concrete is placed, metal reinforcement shall be free from mud, oil, or other nonmetallic coatings that decrease bond. Epoxy-coating of steel reinforcement in accordance with standards referenced in this Code shall be permitted.

8.1.4.2 Metal reinforcement with rust, mill scale, or a combination of both, shall be considered satisfactory, provided the minimum dimensions (including height of deformations) and weight of a hand-wire-brushed test specimen are not less than applicable ASTM specification requirements.

8.1.5 Placing of Reinforcement

8.1.5.1 Reinforcement shall be accurately placed and adequately supported before concrete is placed, and shall be secured against displacement within tolerances permitted in Sec 8.1.5.2 below.

8.1.5.2 Reinforcement shall be placed within the following tolerances unless otherwise specified by the engineer:

- (a) Tolerances for depth d , and minimum concrete cover in flexural members, walls and compression members shall be as set forth in Table 6.8.2.

Table 6.8.2: Tolerances for Placing Reinforcement

Depth of Member, d	Tolerance for d	Tolerance for Minimum Concrete Cover
$d \leq 200$ mm	± 10 mm	-10 mm
$d > 200$ mm	± 13 mm	-13 mm

- (b) Notwithstanding the provision of (a) above, tolerance for the clear distance to formed soffits shall be minus 6 mm and tolerance for cover shall not exceed minus one third ($1/3$) of minimum concrete cover specified in the design drawings or specifications.
- (c) Tolerance for longitudinal location of bends and ends of reinforcement shall be ± 50 mm, except at discontinuous ends of brackets and corbels, where tolerance shall be ± 13 mm and at discontinuous ends of other members, where tolerance shall be ± 25 mm. The tolerance for concrete cover of Sec 8.1.5.2a shall also apply at discontinuous ends of members.

8.1.5.3 Welded wire reinforcement (with ASTM wire size not greater than MW30 or MD30) used in slabs not exceeding 3 m in span shall be permitted to be curved from a point near the top of slab over the support to a point near the bottom of slab at midspan, provided such reinforcement is either continuous over, or securely anchored at support.

8.1.5.4 Welding of crossing bars shall not be permitted for assembly of reinforcement unless authorized by the engineer.

8.1.6 Spacing of Reinforcement

8.1.6.1 The minimum clear spacing between parallel bars in a layer shall be equal to one bar diameter, but not less than 25 mm, or 1.33 times of maximum nominal size of coarse aggregate, whichever is larger.

8.1.6.2 Where parallel reinforcement is placed in two or more layers, bars in the upper layers shall be placed directly above those in the bottom layer with clear distance between layers not less than 25 mm.

8.1.6.3 For compression members, the clear distance between longitudinal bars shall be not less than 1.5 bar diameters nor 40 mm nor 1.33 times of maximum nominal size of coarse aggregate.

8.1.6.4 Clear distance limitation between bars shall apply also to the clear distance between a contact lap splice and adjacent splices or bars.

8.1.6.5 In walls and one-way slabs the maximum bar spacing shall not be more than three times the wall or slab thickness h nor 450 mm.

8.1.6.6 For two-way slabs, maximum spacing of bars shall not exceed twice the slab thickness h nor 450 mm.

8.1.6.7 For temperature steel, maximum spacing shall not exceed 5 times the slab thickness h nor 450 mm.

8.1.6.8 Bundled bars

- (a) Groups of parallel reinforcing bars bundled in contact to act as a single unit shall be limited to four.
- (b) Bundled bars shall be enclosed within stirrups or ties.
- (c) Bars larger than 32 mm diameter shall not be bundled in beams.
- (d) Individual bars within a bundle terminated within the span of flexural members shall terminate at different points with at least $40d_b$ stagger.
- (e) Where spacing limitations and minimum concrete cover are based on bar diameter d_b , a unit of bundled bars shall be treated as a single bar of a diameter derived from the equivalent total area.

8.1.7 Exposure Condition and Cover to Reinforcement

8.1.7.1 The nominal concrete cover to all reinforcement (including links), maximum free water-cement ratio and minimum cement content required for various minimum concrete strengths used in different exposure conditions shall be as specified in Table 6.8.3. However, for mild environment, the minimum concrete cover specified in Sections 8.1.7.2 and 8.1.7.3 for various structural elements may be used.

8.1.7.2 Cast-in-place concrete

- (a) Minimum concrete cover for concrete cast against and permanently exposed to earth shall be 75 mm.
- (b) Concrete exposed to earth or weather, the minimum clear cover shall be as under.

19 mm to 57 mm bar diameter: 50 mm

16 mm diameter bar and smaller: 40 mm

- (c) The following minimum concrete cover may be provided for reinforcement for concrete surfaces not exposed to weather or in contact with ground:

Slabs, Walls:	Minimum Cover
40 mm to 57 mm bar diameter	40
36 mm bar diameter and smaller	20
Beams, Columns :	
Primary reinforcement, Ties, stirrups, spirals	40
Shells, folded plate members :	
19 mm bar diameter and larger	20
16 mm bar diameter and smaller	16

Table 6.8.3*: Concrete Cover and other Requirements for Various Exposure Conditions

Environ ment	Exposure Conditions	Minimum f'_c N/mm ²						
		20	25	30	35	40	45	50
		Nominal cover (mm)						
Mild	Concrete surfaces protected against weather or aggressive conditions	30	25	20	20	20**	20**	20**

Environment	Exposure Conditions	Minimum f'_c N/mm ²						
		20	25	30	35	40	45	50
		Nominal cover (mm)						
Moderate	Concrete surface away from severe rain Concrete subject to condensation Concrete surfaces continuously under water Concrete in contact with non-aggressive soil	40	35	30	25	20	20	20
Severe	Concrete surfaces exposed to severe rain, alternate wetting and drying or severe condensation		45	40	30	25	25	20
Very severe	Concrete surfaces exposed to sea water spray, corrosive fumes			50	40	30	30	25
Extreme	Concrete surfaces exposed to abrasive action, e.g. sea water carrying solids or flowing water with pH \leq 4.5 or machinery or vehicles				60	50	40	30
Maximum water/cement ratio		0.5	0.5	0.5	0.45	0.45	0.40	0.40
Minimum cement content, (kg/m ³)		315	325	350	375	400	410	420
* This Table relates to aggregate of 20 mm nominal maximum size.								
** May be reduced to 15 mm provided the nominal maximum aggregate size does not exceed 15 mm								

8.1.7.3 Precast concrete (manufactured under plant control conditions) :

(a) Concrete exposed to earth or weather:

Bar diameter Minimum cover, mm

Wall Panels:

40 mm to 57 mm diameter 40

36 mm diameter bar and smaller 20

Other Members:

40 mm to 57 mm diameter 50

19 mm to 36 mm diameter 40

16 mm diameter bar and smaller 30

(b) Concrete not exposed to weather or in contact with ground:

<u>Bar diameter</u>	<u>Minimum cover, mm</u>
Slabs, Walls:	
40 mm to 57 mm diameter	30
36 mm diameter bar and smaller	16
Beams, columns :	
Primary reinforcement	$20 \leq d_b \leq 40$
Ties, stirrups, spiral	15
Shells, folded plate members :	
19 mm diameter bar and larger	16
16 mm diameter bar and smaller	10

8.1.7.4 For concrete cast against and permanently exposed to earth, minimum cover shall be 75 mm. If, concrete cover specified in Sec 8.1.7.1 (Table 6.8.3) conflicts with those specified in Sec 8.1.7.2 or Sec 8.1.7.3, the larger value shall be taken.

8.1.7.5 Bundled Bars: Minimum concrete cover shall be equal to the equivalent diameter of the bundle, but need not be greater than 50 mm.

8.1.7.6 Future Extension: Exposed reinforcement, inserts, and plates intended for bonding with future extensions shall be protected from corrosion.

8.1.7.7 Fire Protection: If a thickness of cover for fire protection greater than the concrete covers specified in Sections 8.1.7.1 to 8.1.7.6 is required, such greater thicknesses shall be specified.

8.1.7.8 Corrosive Environments: If a thickness of cover for corrosive environment or other severe exposure conditions greater than the concrete covers specified in Sections 8.1.7.1 to 8.1.7.6 is required, such greater thicknesses shall be specified. For corrosion protection, a specified concrete cover for reinforcement not less than 50 mm for walls and slabs and not less than 65 mm for other members may be used. For precast concrete members a specified concrete cover not less than 40 mm for walls and slabs and not less than 50 mm for other members may be used.

Minimum compressive strength of concrete f'_c for the corrosive environment or other severe exposure conditions shall be 25 MPa with minimum cement of 400 kg per cubic meter. Coarse aggregate shall be 20 mm down well-graded stone chips and fine aggregate shall be coarse sand of minimum FM 2.20.

For any non-structural member like drop wall, railing, fins etc., 12 mm down well graded stone chips may be used as coarse aggregate.

Use of brick chips (khoa) as coarse aggregate is strictly prohibited for the corrosive environment or other severe exposure conditions.

Water cement ratio shall be between 0.4-0.45. Potable water shall be used for all concreting.

8.1.8 Reinforcement Details for Columns

8.1.8.1 Offset Bars: Offset bent longitudinal bars shall conform to the following:

- (a) The maximum slope of inclined portion of an offset bar with axis of column shall not exceed 1 in 6.
- (b) Portions of bar above and below an offset shall be parallel to the axis of column.
- (c) Horizontal support at offset bends shall be provided by lateral ties, spirals, or parts of the floor construction. Horizontal support provided shall be designed to resist 1.5 times the horizontal component of the computed force in the inclined portion of the offset bars. Lateral ties or spirals, if used, shall be placed not more than 150 mm away from points of bend.
- (d) Offset bars shall be bent before placement in the forms (see Sec 8.1.3).
- (e) Where the face of the column above is offset 75 mm or more from the face of the column below, longitudinal bars shall not be permitted to be offset bent. The longitudinal bars adjacent to the offset column faces shall be lap spliced using separate dowels. Lap splices shall conform to Sec 8.2.14.

8.1.8.2 Steel Cores: Load transfer in structural steel cores of composite compression members shall be provided by the following:

- (a) Ends of structural steel cores shall be accurately finished to bear at end bearing splices, with positive provision for alignment of one core above the other in concentric contact.
- (b) At end bearing splices, bearing shall be considered effective to transfer not more than 50 percent of the total compressive stress in the steel core.
- (c) Transfer of stress between column base and footing shall be designed in accordance with Sec 6.8.8.
- (d) Base of structural steel section shall be designed to transfer the total load from the entire composite member to the footing; or, the base shall be designed to transfer the load from the steel core only, provided ample concrete section is available for transfer of the portion of the total load carried by the reinforced concrete section to the footing by compression in the concrete and by reinforcement.

8.1.9 Lateral Reinforcement for Columns

8.1.9.1 Lateral reinforcement for compression members shall conform to the provisions of Sections 8.1.9.3 and 8.1.9.4 below and where shear or torsion reinforcement is required, shall also conform to provisions of Sec 6.4.

8.1.9.2 Lateral reinforcement requirements for composite columns shall conform to Sections 6.3.13.7 and 6.3.13.8 Chapter 6.

8.1.9.3 Spirals: Spiral reinforcement for columns shall conform to Sec 6.3.9.3 Chapter 6 and to the following:

- (a) Spirals shall consist of evenly spaced continuous bar or wire of such size and so assembled as to permit handling and placing without distortion from designed dimensions.
- (b) Size of spirals shall not be less than 10 mm diameter for cast-in-place construction.
- (c) The minimum and maximum clear spacing between spirals shall be 25 mm and 75 mm respectively.
- (d) Anchorage of spiral reinforcement shall be provided by 1.5 extra turns of spiral bar or wire at each end of a spiral unit.
- (e) Splices in spiral reinforcement shall be lap splices of 48 spiral diameter for deformed uncoated bar or wire and 72 spiral diameter for other cases, but not less than 300 mm.
- (f) Spirals shall extend from the top of footing or slab in any storey to the level of the lowest horizontal reinforcement in members supported above.
- (g) Spirals shall extend above termination of spiral to bottom of slab or drop panel, where beams or brackets do not frame into all sides of a column.
- (h) Spirals shall extend to a level at which the diameter or width of capital is 2 times that of the column, in case of columns with capitals.
- (i) Spirals shall be held firmly in place and true to line.

8.1.9.4 Ties: Tie reinforcement for compression members shall conform to the following:

- (a) All bars shall be enclosed by lateral ties, at least 10 mm diameter in size for longitudinal bars 32 mm diameter or smaller, and at least 12 mm diameter in size for 36 mm to 57 mm diameter and bundled longitudinal bars.
- (b) Vertical spacing of ties shall not exceed 16 longitudinal bar diameters or 48 tie diameters, or the least dimension of the compression members.

- (c) Ties shall be arranged such that every corner and alternate longitudinal bar shall have lateral support provided by the corner of a tie with an included angle not more than 135° . No vertical bar shall be farther than 150 mm clear on each side along the tie from such a laterally supported bar. Where longitudinal bars are located around the perimeter of a circle, a complete circular tie is allowed.
- (d) The lowest tie in any storey shall be placed within one-half the required tie spacing from the top most horizontal reinforcement in the slab or footing below. The uppermost tie in any storey shall be within one-half the required tie spacing from the lowest horizontal reinforcement in the slab or drop panel above.
- (e) Where beams or brackets provide concrete confinement at the top of the column on all (four) sides, top tie shall be within 75 mm of the lowest horizontal reinforcement in the shallowest of such beams or brackets.
- (f) Where anchor bolts are placed in the top of columns or pedestals, the bolts shall be enclosed by lateral reinforcement that also surrounds at least four vertical bars of the column or pedestal. The lateral reinforcement shall be distributed within 125 mm of the top of the column or pedestal, and shall consist of at least two 12 mm diameter bars or three 10 mm diameter bars.
- (g) Where longitudinal bars are arranged in a circular pattern, individual circular ties per specified spacing may be used.

8.1.10 Lateral Reinforcement for Beams

8.1.10.1 Compression reinforcement in beams shall be enclosed by ties or stirrups satisfying the size and spacing limitations in Sec 8.1.9.4 above. Such ties or stirrups shall be provided throughout the distance where compression reinforcement is required.

8.1.10.2 Lateral reinforcement for flexural framing members subject to stress reversals or to torsion at supports shall consist of closed ties, closed stirrups, or spirals extending around the flexural reinforcement.

8.1.10.3 Closed ties or stirrups shall be formed in one piece by overlapping standard stirrup or tie end hooks around a longitudinal bar, or formed in one or two pieces lap spliced with a Class B splice (lap of $1.3l_d$) or anchored in accordance with Sec 8.2.10.

8.1.11 Shrinkage and Temperature Reinforcement

8.1.11.1 Where the flexural reinforcement extends in one direction only, reinforcement for shrinkage and temperature stresses shall be provided perpendicular to flexural reinforcement in structural slabs. Shrinkage and temperature reinforcement shall be provided in accordance with Sec 8.1.11.2 below.

8.1.11.2 Deformed reinforcement conforming to Sec 5.3.2 Chapter 5 shall be provided in accordance with the following:

- (a) Area of shrinkage and temperature reinforcement shall provide at least the following ratios of reinforcement area to gross concrete area:
- Slabs where reinforcement with $f_y = 275 \text{ N/mm}^2$ or 350 N/mm^2 are used: 0.0020
- Slabs where reinforcement with $f_y = 420 \text{ N/mm}^2$ are used: 0.0018
- Slabs where reinforcement with f_y exceeding 420 N/mm^2 are used: $0.0018 \left(\frac{420}{f_y} \right)$
- In any case, the reinforcement ratio shall not be less than 0.0014.
- (b) Area of shrinkage and temperature reinforcement for brick aggregate concrete shall be at least 1.5 times that provided in (a) above.
- (c) Shrinkage and temperature reinforcement shall be spaced not farther apart than 5 times the slab thickness, nor 450 mm.
- (d) At all sections where required, reinforcement for shrinkage and temperature stresses shall develop the specified yield strength f_y in tension in accordance with Sec 8.2.

8.1.12 Requirements for Structural Integrity

8.1.12.1 In the detailing of reinforcement and connections, members of a structure shall be effectively tied together to improve integrity of the overall structure.

8.1.12.2 The minimum requirements for cast-in-place construction shall be:

- (a) In one-way slab construction, at least one bottom bar shall be continuous or shall be spliced over the support with a Class A tension splice. At non-continuous supports, the bars may be terminated with a standard hook.
- (b) Beams at the perimeter of the structure shall have at least one-sixth of the tension reinforcement required for negative moment at the support, but not less than two bars and one-quarter of the positive moment reinforcement required at midspan, but not less than two bars made continuous over the span length passing through the region bounded by the longitudinal reinforcement of the column around the perimeter and tied with closed stirrups. Closed stirrups need not be extended through any joints. The required continuity may be provided with top reinforcement spliced at mid-span and bottom reinforcement spliced at or near the support with Class B tension splices.

- (c) When closed stirrups are not provided, in other than perimeter beams, at least one-quarter of the positive moment reinforcement required at mid-span, but not less than two bars shall pass through the region bounded by the longitudinal reinforcement of the column and shall be continuous or shall be spliced over the support with a Class B tension splice. At non-continuous supports the bars shall be anchored to develop f_y at the face of the support using a standard hook.

8.1.12.3 To effectively tie elements together, tension ties shall be provided in the transverse, longitudinal, and vertical directions and around the perimeter of the structure for precast concrete construction.

8.1.13 Connections

8.1.13.1 Enclosure shall be provided for splices of continuing reinforcement and for anchorage of terminating reinforcement at connections of principal framing elements (such as beams and columns),

8.1.13.2 External concrete or internal closed ties, spirals, or stirrups shall be used as enclosures at connections.

8.2 Development and Splices of Reinforcement

8.2.1 Development of Reinforcement - General

Calculated tension or compression stress in reinforcement at each section of reinforced concrete members shall be developed on each side of that section by embedment length, hook or mechanical device, or a combination thereof. Hooks may be used in developing bars in tension only.

8.2.2 Limitation

The values of $\sqrt{f'_c}$ used in Sec 8.2 shall not exceed 8.3 MPa. In addition to requirements stated here that affect detailing of reinforcement, structural integrity requirements of Sec 8.1.12 shall be satisfied.

8.2.3 Development of Deformed Bars and Deformed Wires in Tension

8.2.3.1 Development length for deformed bars and deformed wire in tension, l_d shall be determined from either Sec 8.2.3.2 or Sec 8.2.3.3 and applicable modification factors of Sections 8.2.3.4 and 8.2.3.5, but l_d shall not be less than 300 mm.

8.2.3.2 For deformed bars or deformed wire, l_d shall be as follows:

Spacing and cover	19 mm diameter and smaller bars and deformed wires	20 mm diameter and larger bars
Clear spacing of bars or wires being developed or spliced not less than d_b , clear cover not less than d_b , and stirrups or ties throughout l_d not less than the Code minimum Or, Clear spacing of bars or wires being developed or spliced not less than $2d_b$ and clear cover not less than d_b	$\left(\frac{f_y \psi_t \psi_e}{2.1 \lambda \sqrt{f'_c}}\right) d_b$	$\left(\frac{f_y \psi_t \psi_e}{1.7 \lambda \sqrt{f'_c}}\right) d_b$
Other cases		$\left(\frac{f_y \psi_t \psi_e}{1.1 \lambda \sqrt{f'_c}}\right) d_b$

8.2.3.3 For deformed bars or deformed wire, l_d shall be

$$l_d = \left(\frac{f_y}{1.1 \lambda \sqrt{f'_c}} \frac{\psi_t \psi_e \psi_s}{\left(\frac{c_b + K_{tr}}{d_b}\right)} \right) d_b \quad (6.8.1)$$

In which the confinement term $\frac{c_b + K_{tr}}{d_b}$ shall not be taken greater than 2.5, and

$$K_{tr} = \frac{40A_{tr}}{sn} \quad (6.8.2)$$

Where, n is the number of bars or wires being spliced or developed along the plane of splitting. It shall be permitted to use $K_{tr} = 0$ as a design simplification even if transverse reinforcement is present.

8.2.3.4 The factors used in the expressions for development of deformed bars and deformed wires in tension in Sec 8.2.3 are as follows:

- Where horizontal reinforcement is placed such that more than 300 mm of fresh concrete is cast below the development length or splice, $\psi_t = 1.3$. For other cases, $\psi_t = 1.0$.
- For epoxy-coated bars or wires with cover less than $3d_b$, or clear spacing less than $6d_b$, $\psi_e = 1.5$. For all other epoxy-coated bars or wires, $\psi_e = 1.2$. For uncoated and zinc-coated (galvanized) reinforcement, $\psi_e = 1.0$. However, the product $\psi_t \psi_e$ need not be greater than 1.7.

- (c) For 19 mm diameter and smaller bars, and deformed wires, $\psi_s = 0.8$.
For 20 mm diameter and larger bars, $\psi_s = 1.0$.
- (d) Where lightweight concrete is used, λ shall not exceed 0.75 unless f_{ct} is specified (see Sec 6.1.9.1 Chapter 6). Where normal weight concrete is used, $\lambda = 1.0$.

8.2.3.5 Excess Reinforcement: Development length may be reduced by the factor $\left[\frac{A_s \text{ required}}{A_s \text{ provided}} \right]$ where reinforcement in a flexural member is in excess of that required by analysis except where anchorage or development for f_y is specifically required or the reinforcement is designed under the provisions of Sec 8.3.2(b).

8.2.4 Development of Deformed Bars and Deformed Wires in Compression

8.2.4.1 Development length for deformed bars and deformed wire in compression, l_{dc} shall be determined from Sec 8.2.4.2 and applicable modification factors of Sec 8.2.4.3, but l_{dc} shall not be less than 200 mm.

8.2.4.2 For deformed bars and deformed wire, l_{dc} shall be taken as the larger of $\frac{0.24f_y d_b}{\lambda \sqrt{f'_c}}$ and $0.043f_y d_b$ with λ as given in Sec 8.2.3.4(d) and the constant 0.043 carries the unit of mm^2/N .

8.2.4.3 Length l_{dc} in Sec 8.2.4.2 shall be permitted to be multiplied by the applicable factors for:

- (a) Reinforcement in excess of that required by analysis: $\left[\frac{A_s \text{ required}}{A_s \text{ provided}} \right]$
- (b) Reinforcement enclosed within spiral reinforcement not less than 6 mm diameter and not more than 100 mm pitch or within 12 mm diameter ties in conformance with Sec 8.1.9.4 and spaced at not more than 100 mm on center: 0.75

8.2.5 Development of Bundled Bars

8.2.5.1 Development length of individual bars within a bundle, in tension or compression, shall be that for the individual bar, increased 20 percent for 3 bar bundles and 33 percent for 4 bar bundles.

8.2.5.2 For determining the appropriate spacing and cover values in Sec 8.2.3.2, the confinement term in Sec 8.2.3.3, and the ψ_e factor in Sec 8.2.3.4(b), a unit of bundled bars shall be treated as a single bar of a diameter derived from the equivalent total area and having a centroid that coincides with that of the bundled bars.

8.2.6 Development of Standard Hooks in Tension

8.2.6.1 Development length l_{dh} for deformed bars in tension terminating in a standard hook shall be computed as the product of the basic development length for deformed bars, l_{dh} of Sec 8.2.6.2 below and the applicable modification factor(s) of Sec 8.2.6.3, but l_{dh} shall be not less than $8d_b$ nor less than 150 mm.

8.2.6.2 For deformed bars, l_{dh} shall be $\frac{0.24\psi_e f_y d_b}{\lambda \sqrt{f'_c}}$ with ψ_e taken as 1.2 for epoxy-coated reinforcement, and λ taken as 0.75 for lightweight concrete. For other cases, ψ_e and λ shall be taken as 1.0.

8.2.6.3 Length l_{dh} in Sec 8.2.6.2 shall be permitted to be multiplied by the following applicable factors:

- | | |
|--|--|
| (a) For 36 mm diameter bar and smaller hooks with side cover (normal to plane of hook) not less than 65 mm, and for 90° hook with cover on bar extension beyond hook not less than 50 mm | 0.7 |
| (b) For 90° hooks of 36 mm diameter bar and smaller bars that are either enclosed within ties or stirrups perpendicular to the bar being developed, spaced not greater than $3d_b$ along l_{dh} ; or enclosed within ties or stirrups parallel to the bar being developed, spaced not greater than $3d_b$ along the length of the tail extension of the hook plus bend | 0.8 |
| (c) For 180° hooks of 36 mm diameter bar and smaller bars that are enclosed within ties or stirrups perpendicular to the bar being developed, spaced not greater than $3d_b$ along l_{dh} . | 0.8 |
| (d) Where anchorage or development for f_y is not specifically required, reinforcement in excess of that required by analysis | $\left[\frac{A_s \text{ required}}{A_s \text{ provided}} \right]$ |

In Sections 8.2.6.3(b) and 8.2.6.3(c), d_b is the diameter of the hooked bar, and the first tie or stirrup shall enclose the bent portion of the hook, within $2d_b$ of the outside of the bend.

8.2.6.4 For bars being developed by a standard hook at discontinuous ends of members with both side cover and top (or bottom) cover over hook less than 65 mm, the hooked bar shall be enclosed within ties or stirrups perpendicular to the bar being developed, spaced not greater than $3d_b$ along l_{dh} . The first tie or stirrup shall enclose the bent portion of the hook, within $2d_b$ of the outside of the bend, where d_b is the diameter of the hooked bar. For this case, the factors of Sec 8.2.6.3(b) and (c) shall not apply.

8.2.6.5 Hooks shall not be considered effective in developing bars in compression.

8.2.7 Development of Flexural Reinforcement - General

8.2.7.1 Tension reinforcement may be developed by bending across the web to be anchored or made continuous with reinforcement on the opposite face of member.

8.2.7.2 Critical sections for development of reinforcement in flexural members are at points of maximum stress and at points within the span where adjacent reinforcement terminates, or is bent. In addition, the provisions of Sec 8.2.8.3 shall also be satisfied.

8.2.7.3 Reinforcement shall extend beyond the point at which it is no longer required to resist flexure for a distance not less than d nor less than $12d_b$, except at supports of simple spans and at free end of cantilevers.

8.2.7.4 Continuing reinforcement shall have an embedment length not less than the development length l_d beyond the point where the bent or terminated tension reinforcement is no longer needed to resist bending.

8.2.7.5 No flexural bar shall be terminated in a tension zone unless one of the following conditions is satisfied:

- V_u at the location of termination is not over two-thirds of ϕV_n .
- Stirrup area in excess of that normally required for shear and torsion is provided over a distance along each terminated bar or wire equal to $0.75d$ from the point of cut-off. Excess stirrup area A_v shall be not less than $\frac{0.41b_w s}{f_{yt}}$. Spacing, s shall not exceed $\frac{d}{8\beta_b}$, where β_b is the ratio of area of reinforcement cut off to total area of tension reinforcement at the section.
- For 36 mm diameter bar and smaller, the continuing bars provide twice the area required for flexure at the cut-off point and the shear V_u does not exceed three-quarter of ϕV_n .

8.2.7.6 Where the reinforcement stress is not directly proportional to moment, such as in sloped, stepped, or tapered footings, brackets, deep flexural members, or members in which tension reinforcement is not parallel to the compression face, adequate anchorage shall be provided for the tension reinforcement. See Sections 8.2.8.4 and 8.2.9.4 for deep flexural members.

8.2.8 Development of Positive Moment Reinforcement

8.2.8.1 At least one-third of the positive moment reinforcement in simple members and one-fourth of the positive moment reinforcement in continuous members shall extend along the same face of member into the support. In beams, such reinforcement shall extend into the support at least 150 mm.

8.2.8.2 When the flexural member is a part of the primary lateral load resisting system, positive moment reinforcement extended into the support by Sec 8.2.8.1 above shall be anchored to develop the specified yield strength f_y in tension at the face of support.

8.2.8.3 At simple supports and at points of inflection, positive moment tension reinforcement shall be limited to a diameter such that l_d computed for f_y by Sec 8.2.3 satisfies Eq. 6.8.3, except that Eq. 6.8.3 need not be satisfied for reinforcement terminating beyond the centreline of simple supports by a standard hook or a mechanical anchorage at least equivalent to a standard hook.

$$l_d \leq \frac{M_n}{V_u} + l_a \quad (6.8.3)$$

Where,

M_n = nominal moment strength assuming all reinforcement at section to be stressed to f_y .

V_u = factored shear force at section

l_a = at a support, embedded length of bar beyond centre of support; at point of zero moment, shall be limited to d or $12d_b$, whichever is greater.

The value of $\frac{M_n}{V_u}$ may be increased 30 percent when the ends of reinforcement are confined by a compressive reaction.

8.2.8.4 At simple supports of deep beams, positive moment tension reinforcement shall be anchored to develop f_y in tension at the face of the support except that if design is carried out using Appendix I, the positive moment tension reinforcement shall be anchored in accordance with Sec I.4.3 Appendix I. At interior supports of deep beams, positive moment tension reinforcement shall be continuous or be spliced with that of the adjacent spans.

8.2.9 Development of Negative Moment Reinforcement

8.2.9.1 Negative moment reinforcement in a continuous, restrained, or cantilever member, or in any member of a rigid frame, shall be anchored in or through the supporting member by embedment length, hooks or mechanical anchorage.

8.2.9.2 Negative moment reinforcement shall have an embedment length into the span as required by Sections 8.2.1, 8.2.2 and 8.2.7.3.

8.2.9.3 At least one-third of the total tension reinforcement provided for negative moment at the support shall be extended beyond the point of inflection a distance not less than d , $\frac{l_n}{16}$, or $12d_b$, whichever is greater.

8.2.9.4 At interior supports of deep flexural members, negative moment tension reinforcement shall be continuous with that of the adjacent spans.

8.2.10 Development of Shear Reinforcement

8.2.10.1 Shear reinforcement shall be carried as close to compression and tension surfaces of member as cover requirements and proximity of other reinforcement permits.

8.2.10.2 The ends of single leg, simple U, or multiple U-stirrups shall be anchored by one of the following means:

- (a) By a standard hook around longitudinal reinforcement for ASTM MD200 wires, and 16 mm diameter bars and smaller and for 19 mm to 25 mm diameter bars with $f_{yt} \leq 280 \text{ N/mm}^2$.
- (b) For 19 mm to 25 mm diameter stirrups with f_{yt} greater than 280 N/mm^2 , a standard stirrup hook around a longitudinal bar plus an embedment between mid-height of the member and the outside end of the hook equal to or greater than $\frac{0.17d_b f_{yt}}{\lambda \sqrt{f'_c}}$.
- (c) For each leg of welded plain wire reinforcement forming simple U-stirrups, either: (i) Two longitudinal wires spaced at a 50 mm spacing along the member at the top of the U; or (ii) One longitudinal wire located not more than $\frac{d}{4}$ from the compression face and a second wire closer to the compression face and spaced not less than 50 mm from the first wire. The second wire shall be permitted to be located on the stirrup leg beyond a bend, or on a bend with an inside diameter of bend not less than $8d_b$.
- (d) For each end of a single leg stirrup of welded wire reinforcement, two longitudinal wires at a minimum spacing of 50 mm and $\frac{d}{4}$ with the inner wire at least the greater of $\frac{d}{4}$ or 50 mm from $\frac{d}{2}$. Outer longitudinal wire at tension face shall not be farther from the face than the portion of primary flexural reinforcement closest to the face.
- (e) In joist construction, for 13 mm diameter bar and ASTM MD130 wire and smaller, a standard hook.

8.2.10.3 Each bend in the continuous portion of a simple U-stirrup or multiple U-stirrup shall enclose a longitudinal bar between anchored ends.

8.2.10.4 If extended into the region of tension, longitudinal bars bent to act as shear reinforcement shall be continuous with longitudinal reinforcement and, if extended into a region of compression, shall be anchored beyond mid-depth $\frac{d}{2}$ as specified for development length in Sec 8.2.3 for that part of f_{yt} required to satisfy Eq. 6.6.58.

8.2.10.5 Pairs of U-stirrups or ties so placed as to form a closed unit shall be considered properly spliced when length of laps are $1.3l_d$. In members at least 450 mm deep, such splices with $A_b f_{yt}$ not more than 40 kN per leg shall be considered adequate if stirrup legs extend the full available depth of member.

8.2.11 Development of Plain Bars

For plain bars, the minimum development length shall be twice that of deformed bars specified in Sections 8.2.1 to 8.2.10 above.

8.2.12 Splices of Reinforcement - General

8.2.12.1 Splices of reinforcement shall be made only as required or permitted on design drawings, or in specifications, or as authorized by the engineer.

8.2.12.2 Lap splices

- (a) Lap splices shall not be used for 36 mm diameter bars and larger, except as provided in Sections 8.2.14.2 Chapter 8 and 6.8.8.2.3 Chapter 6.
- (b) Lap splices of bundled bars shall be based on the lap splice length required for individual bars within the bundle, increased in accordance with Sec 8.2.5. Individual bar splices within a bundle shall not overlap. Entire bundles shall not be lap spliced.
- (c) Bars spliced by noncontact lap splices in flexural members shall not be spaced transversely farther apart than one-fifth the required lap splice length, nor 150 mm.

8.2.12.3 Welded splices and mechanical connections

- (a) Welded splices and other mechanical connections are allowed.
- (b) Except as provided in this Code, all welding shall conform to "Structural Welding Code - Reinforcing Steel" (AWS D1.4).
- (c) Welded splices shall be butted and welded to develop in tension at least 125 percent of specified yield strength f_y of the bar.
- (d) A full mechanical connection shall develop in tension or compression, as required, at least 125 percent of specified yield strength f_y of the bar.
- (e) Welded splices and mechanical connections not meeting the requirements of (c) or (d) above are allowed only for 16 mm diameter bar or smaller and in accordance with Sec 8.2.13.4.

8.2.13 Splices of Deformed Bars and Deformed Wire in Tension

8.2.13.1 The minimum length of lap for tension splices shall be as required for Class A or B splice, but not less than 300 mm, where the classification shall be as follows:

Class - A splice: $1.0l_d$

Class - B splice: $1.3l_d$

Where, l_d is calculated in accordance with Sec 8.2.3 to develop f_y but without the 300 mm minimum of Sec 8.2.3.1 and without the modification factor of Sec 8.2.3.5.

8.2.13.2 Lap splices of deformed bars and deformed wire in tension shall be class B splices except that Class A splices are allowed when the area of reinforcement provided is at least twice that required by analysis over the entire length of the splice, and one-half or less of total reinforcement is spliced within the required lap length.

8.2.13.3 Where area of reinforcement provided is less than twice that required by analysis, welded splices or mechanical connections used shall meet the requirements of Sec 8.2.12.3(c) or Sec 8.2.12.3(d) above.

8.2.13.4 Welded splices or mechanical connections not meeting the requirements of Sec 8.2.12.3(c) or Sec 8.2.12.3(d) shall be permitted for 16 mm diameter bars or smaller if the following requirements are met:

- (a) Splices shall be staggered at least 600 mm and in such manner as to develop at every section at least twice the calculated tensile force at the section but not less than 140 N/mm^2 for total area of reinforcement provided.
- (b) Spliced reinforcement stress shall be taken as the specified splice strength, in computing tensile force developed at each section, but not to exceed f_y . Unspliced reinforcement stress shall be taken as a fraction of f_y defined by the ratio of the shortest actual development length provided beyond the section to l_d but not to be taken greater than f_y .

8.2.13.5 When bars of different size are lap spliced in tension, splice length shall be the larger of l_d of larger bar and tension lap splice length of smaller bar.

8.2.13.6 Splices in tension tie members shall be made with a full welded splice or full mechanical connection in accordance with Sec 8.2.12.3(c) or (d) and splices in adjacent bars shall be staggered at least 750 mm.

8.2.14 Splices of Deformed Bars in Compression

8.2.14.1 The minimum length of lap for compression splice shall be $0.071f_y d_b$ for f_y equal to 420 N/mm^2 or less or $(0.13f_y - 24)d_b$ for f_y greater than 420 N/mm^2 , but not less than 300 mm. For f'_c less than 21 N/mm^2 , length of lap shall be increased by one-third.

8.2.14.2 When bars of different diameters are lap spliced in compression, the splice length shall be the larger of the development length, l_{dc} of the larger bar, and the compression splice length of the smaller bar. Lap splices of 40 mm diameter bars to 36 mm diameter and smaller bars shall be permitted.

8.2.14.3 Welded splices or mechanical connections used in compression shall satisfy the requirements of Sec 8.2.12.3(c) or Sec 8.2.12.3(d).

8.2.14.4 End bearing splices

- (a) Compression splices for bars required to transmit compressive stress only may consist of end bearing of square cut ends held in concentric contact by a suitable device.
- (b) Bar ends shall terminate in flat surfaces within 1.5° of a right angle to the axis of the bars, and shall be fitted within 3 degrees of full bearing after assembly.
- (c) End bearing splices shall be used only in members containing closed ties, closed stirrups or spirals.

8.2.15 Special Splice Requirements for Columns

8.2.15.1 Lap splices, butt welded splices, mechanical connections, or end-bearing splices shall be used with the limitations of Sections 8.2.15.2 to 8.2.15.4 below. A splice shall satisfy the requirements for all load combinations for the column.

8.2.15.2 Lap splices in columns

- (a) Lap splices shall conform to Sec 8.2.14.1, Sec 8.2.14.2, and where applicable to Sec 8.2.15.2(d) or Sec 8.2.15.2(e) below, where the bar stresses due to factored loads is compressive.
- (b) Where the bar stress due to factored loads is tensile and does not exceed $0.5f_y$ in tension, lap splices shall be Class B tension lap splices if more than one-half of the bars are spliced at any section, or Class A tension lap splices if half or fewer of the bars are spliced at any section and alternate lap splices are staggered by l_d .
- (c) Where the bar stress due to factored loads is greater than $0.5f_y$ in tension, lap splices shall be Class B tension lap splices.
- (d) In tied reinforced compression members, if throughout lap splice length ties have an effective area of at least $0.0015h_s$ in both directions, lap splice length is permitted to be multiplied by 0.83, but lap length shall not be less than 300 mm. Tie legs perpendicular to dimension h shall be used in determining effective area.
- (e) For spirally reinforced compression members, lap splice length of bars within a spiral is permitted to be multiplied by 0.75, but lap length shall not be less than 300 mm.

8.2.15.3 Welded splices or mechanical connectors in columns: Welded splices or mechanical connectors in columns shall meet the requirements of Sec 8.2.12.3(c) or Sec 8.2.12.3(d).

8.2.15.4 End bearing splices in columns: End bearing splices complying with Sec 8.2.14.4 may be used for column bars stressed in compression provided the splices are staggered or additional bars are provided at splice locations. The continuing bars in each face of the column shall have a tensile strength at least $0.25f_y$ times the area of the vertical reinforcement in that face.

8.2.16 Splices of Plain Bars

For plain bars, the minimum length of lap shall be twice that of deformed bars specified in Sections 8.2.12 to 8.2.15 above.

8.2.17 Development of headed and mechanically anchored deformed bars in tension

8.2.17.1 Development length for headed deformed bars in tension, l_{dt} shall be determined from Sec 8.2.17.2. Use of heads to develop deformed bars in tension shall be limited to conditions satisfying (a) through (f):

- (a) Bar f_y shall not exceed 420 MPa;
- (b) Bar size shall not exceed 36 mm diameter;
- (c) Concrete shall be normal weight;
- (d) Net bearing area of head A_{brg} shall not be less than $4A_b$;
- (e) Clear cover for bar shall not be less than $2d_b$; and
- (f) Clear spacing between bars shall not be less than $4d_b$.

8.2.17.2 For headed deformed bars, development length in tension l_{dt} shall be $0.19 \frac{\psi_e f_y}{\sqrt{f'_c}} d_b$, where the value of f'_c used to calculate l_{dt} shall not exceed 40 MPa, and factor ψ_e shall be taken as 1.2 for epoxy-coated reinforcement and 1.0 for other cases. Where reinforcement provided is in excess of that required by analysis, except where development of f_y is specifically required, a factor of $\frac{A_{s,required}}{A_{s,provided}}$ may be applied to the expression for l_{dt} . Length l_{dt} shall not be less than the larger of $8d_b$ and 150 mm.

8.2.17.3 Heads shall not be considered effective in developing bars in compression.

8.2.17.4 Any mechanical attachment or device capable of developing f_y of reinforcement is allowed, provided that test results showing the adequacy of such attachment or device are approved by the Engineer. Development of reinforcement shall be permitted to consist of a combination of mechanical anchorage plus additional embedment length of reinforcement between critical section and mechanical attachment or device.

8.2.18 Development of Welded Deformed Wire Reinforcement in Tension

8.2.18.1 Development length for welded deformed wire reinforcement in tension, l_d measured from the point of critical section to the end of wire shall be computed as the product of, l_d from Sec 8.2.3.2 or Sec 8.2.3.3, times welded deformed wire reinforcement factor, ψ_w from 8.2.18.2 or 8.2.18.3. It shall be permitted to reduce l_d in accordance with Sec 8.2.3.5 when applicable, but l_d shall not be less than 200 mm except in computation of lap splices by Sec 8.2.20. When using ψ_w from Sec 8.2.18.2, it shall be permitted to use an epoxy-coating factor ψ_e of 1.0 for epoxy-coated welded deformed wire reinforcement in Sections 8.2.3.2 and 8.2.3.3.

8.2.18.2 For welded deformed wire reinforcement with at least one cross wire within l_d and not less than 50 mm from the point of the critical section, ψ_w shall be the greater of $\left(\frac{f_y - 240}{f_y}\right)$ and $\left(\frac{5d_b}{s}\right)$ but not greater than 1.0, where s is the spacing between the wires to be developed.

8.2.18.3 For welded deformed wire reinforcement with no cross wires within l_d or with a single cross wire less than 50 mm from the point of the critical section, ψ_w shall be taken as 1.0, and l_d shall be determined as for deformed wire.

8.2.18.4 Where any plain wires, or deformed wires larger than ASTM D 31, are present in the welded deformed wire reinforcement in the direction of the development length, the reinforcement shall be developed in accordance with Sec 8.2.19.

8.2.19 Development of Welded Plain Wire Reinforcement in Tension

Yield strength of welded plain wire reinforcement shall be considered developed by embedment of two cross wires with the closer cross wire not less than 50 mm from the point of the critical section. However, l_d shall not be less than

$$l_d = 3.3 \frac{A_b}{s} \frac{f_y}{\lambda \sqrt{f'_c}} \quad (6.8.4)$$

Where l_d is measured from the point of the critical section to the outermost crosswire, s is the spacing between the wires to be developed, and λ as given in Sec 8.2.3.4(d). Where reinforcement provided is in excess of that required, l_d may be reduced in accordance with Sec 8.2.3.5. Length, l_d shall not be less than 150 mm except in computation of lap splices by Sec 8.2.21.

8.2.20 Splices of Welded Deformed Wire Reinforcement in Tension

8.2.20.1 Minimum lap splice length of welded deformed wire reinforcement measured between the ends of each reinforcement sheet shall be not less than the larger of $1.3l_d$ and 200 mm, and the overlap measured between outermost cross wires of each reinforcement sheet shall be not less than 50 mm, where l_d is calculated in accordance with Sec 8.2.18 to develop f_y .

8.2.20.2 Lap splices of welded deformed wire reinforcement, with no cross wires within the lap splice length, shall be determined as for deformed wire.

8.2.20.3 Where any plain wires, or deformed wires larger than ASTM MD200, are present in the welded deformed wire reinforcement in the direction of the lap splice or where welded deformed wire reinforcement is lap spliced to welded plain wire reinforcement, reinforcement shall be lap spliced in accordance with Sec 8.2.21.

8.2.21 Splices of Welded Plain Wire Reinforcement in Tension

Minimum length of lap for lap splices of welded plain wire reinforcement shall be in accordance with Sections 8.2.21.1 and 8.2.21.2.

8.2.21.1 Where A_s provided is less than twice that required by analysis at splice location, length of overlap measured between outermost cross wires of each reinforcement sheet shall be not less than the largest of one spacing of cross wires plus 50 mm, $1.5l_d$ and 150 mm, where l_d is calculated in accordance with Sec 8.2.19 to develop f_y .

8.2.21.2 Where A_s provided is at least twice that required by analysis at splice location, length of overlap measured between outermost cross wires of each reinforcement sheet shall not be less than the larger of $1.5l_d$ and 50 mm, where l_d is calculated in accordance with Sec 8.2.19 to develop f_y .

8.3 Earthquake-Resistant Design Provisions

8.3.1 Scope

This section contains special requirements for design and construction of reinforced concrete members of a structure for which the design forces, related to earthquake motions, have been determined on the basis of energy dissipation in the nonlinear range of response.

8.3.2 Provisions

- (a) The provisions of Chapter 6, shall apply except as modified by the provisions of this Section.
- (b) Structures assigned to seismic design category SDC D (see Chapter 2), all reinforced concrete structures shall satisfy the requirements of special seismic detailing as given in Sections 8.3.3 to 8.3.8 in addition to the requirements of Chapter 6. The provisions for special moment frames shall not permit the use of slab without beam as part of seismic force-resisting system.

- (c) Structures assigned to SDC C (see Chapter 2), all reinforced concrete structures shall be built to satisfy the requirements of intermediate seismic detailing as given in Sec 8.3.10 in addition to the requirements of Chapter 6.
- (d) Structures assigned to SDC B (see Chapter 2), all reinforced concrete structures shall be built to satisfy the requirements of ordinary detailing as given in Sec 8.3.9 in addition to the requirements of Chapter 6.
- (e) Structures in lower SDCs are permitted to design with detailing provisions of higher SDCs to take advantage of lower design force levels.

8.3.3 General Requirements

8.3.3.1 Analysis and proportioning of structural members

- (a) The interaction of all structural and nonstructural members shall be considered in the analysis.
- (b) Rigid members which are not a part of the lateral force resisting system are allowed provided their effect on the response of the system is considered and accommodated in the structural design. Consequences of failure of structural and nonstructural members which are not a part of the lateral force resisting system shall also be considered.
- (c) Structural members below base of structure required to transmit forces resulting from earthquake effects to the foundation shall also comply with the requirements of this section.
- (d) All structural members which are not a part of the lateral force resisting system shall conform to Sec 8.3.9.

8.3.3.2 Strength reduction factors

Strength reduction factors shall be in accordance with Sections 6.2.3.2 to 6.2.3.4.

8.3.3.3 Concrete in special moment frames and special structural walls

Compressive strength f'_c of the concrete shall be not less than 21 N/mm². Specified compressive strength of light-weight concrete, f'_c shall not exceed 35MPa unless demonstrated by experimental evidence. Modification factor λ for lightweight concrete in Sec 8.3 shall be in accordance with Sec 6.1.8 unless noted otherwise.

8.3.3.4 Reinforcement in special moment frames and special structural walls

- (a) Requirements of Sec 8.3.3.4 shall apply to special moment frames, special structural walls and all components of special structural walls including coupling beams and wall piers.

- (b) Deformed reinforcement resisting earthquake-induced flexural and axial force, or both, shall comply with ASTM A706 Grade 420. Alternatively only BDS ISO 6935-2 Grades 300, 350, 400 and 420 or ASTM A615 Grades 275 and 420 reinforcement shall be permitted if:
- (i) The actual yield strength based on mill tests does not exceed f_y by more than 125 N/mm² (retests shall not exceed this value by more than an additional 20 N/mm²); and
- (ii) The ratio of the actual tensile strength to the actual yield strength is not less than 1.25.
- (iii) Minimum elongation in 200 mm shall be at least 14 percent for bar dia. 10 mm to 20 mm, at least 12 percent for bar dia. 22 mm through 36 mm, and at least 10 percent for bar dia. 40 mm to 60 mm.
- (c) The value of f_{yt} used to compute the amount of confinement reinforcement shall not exceed 700 N/mm².
- (d) The value of f_y or f_{yt} used in design of shear reinforcement shall conform to Sec 6.4.3.2.

8.3.3.5 Welding

Reinforcement required by factored load combinations which include earthquake effect shall not be welded except as specified in Sections 8.3.4.2(d) and 8.3.5.3(b). In addition, welding shall not be permitted on stirrups, ties, inserts, or other similar elements to longitudinal reinforcement required by design.

8.3.4 Flexural Members of Special Moment Frames

8.3.4.1 Scope

Requirements of this section shall apply to special moment frame members; (i) resisting earthquake induced forces, and (ii) proportioned primarily to resist flexure. These frame members shall also satisfy the following conditions. The requirements are also shown in Figure 6.8.1.

- (a) Factored axial compressive force on frame member shall not exceed $0.1A_g f'_c$.
- (b) Clear span for the member, l_n shall not be less than four times its effective depth.
- (c) The width to depth ratio shall be at least 0.3.

- (d) The width shall not be (i) less than 250 mm and (ii) more than the width of the supporting member (measured on a plane perpendicular to the longitudinal axis of the flexural member) plus distances on each side of the supporting member neither exceeding three-fourths of the depth of the flexural member c_1 nor width of supporting member c_2 .

8.3.4.2 Longitudinal reinforcement

- (a) At any section of a flexural member and for the top as well as for the bottom reinforcement, the amount of reinforcement shall be not less than $0.25 \frac{f'_c}{f_y} b_w d$ or $1.4 \frac{b_w d}{f_y}$ and the reinforcement ratio, ρ shall not exceed 0.025 (Figure 6.8.2). At least two bars shall be provided continuously both top and bottom. The positive moment strength at the face of the joint shall be not less than one-half of the negative moment strength provided at that face as shown in Figure 6.8.2. Neither the negative nor the positive moment strength at any section along the member length shall be less than one-fourth the maximum moment strength provided at the face of either joint.
- (b) Lap splices of flexural reinforcement shall be permitted only if hoop or spiral reinforcement is provided over the lap length. Maximum spacing of the transverse reinforcement enclosing the lapped bars shall not exceed $\frac{d}{4}$ nor 100 mm. Lap splices shall not be used; (i) within the joints, (ii) within a distance of twice the member depth from the face of the joint, and (iii) at locations where analysis indicates flexural yielding caused by inelastic lateral displacements of the frame. These requirements are shown in Figure 6.8.3.

Welded splices and mechanical connections conforming to Sections 8.2.12.3(a) to 8.2.12.3(d) are allowed for splicing provided not more than alternate bars in each layer of longitudinal reinforcement are spliced at a section and the centre to centre distance between splices of adjacent bars is 600 mm or more measured along the longitudinal axis of the frame member. Welded splices and mechanical connections (Type 1) shall not be used within a distance equal to twice the member depth from the column or beam faces for special moment frames or from sections where yielding of the reinforcement is likely to occur as a result of inelastic lateral displacement.

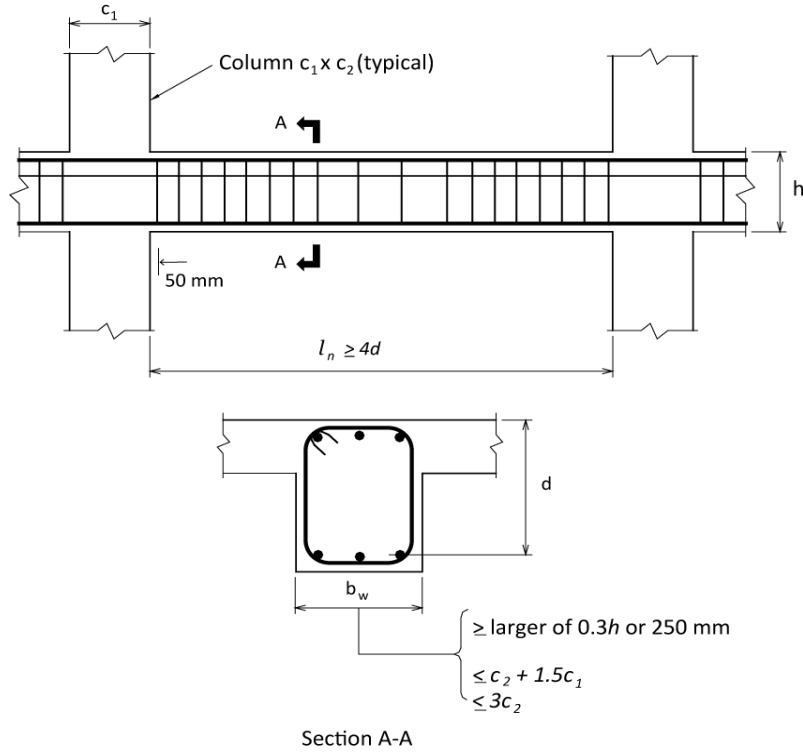
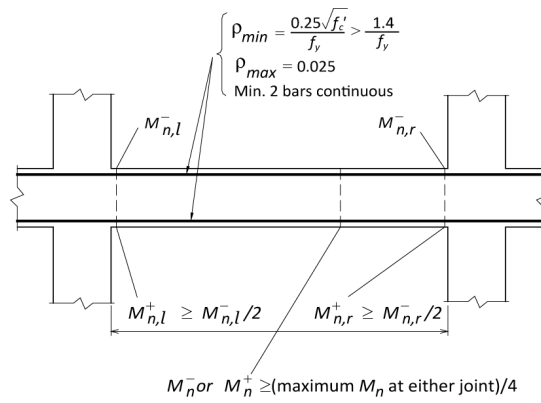
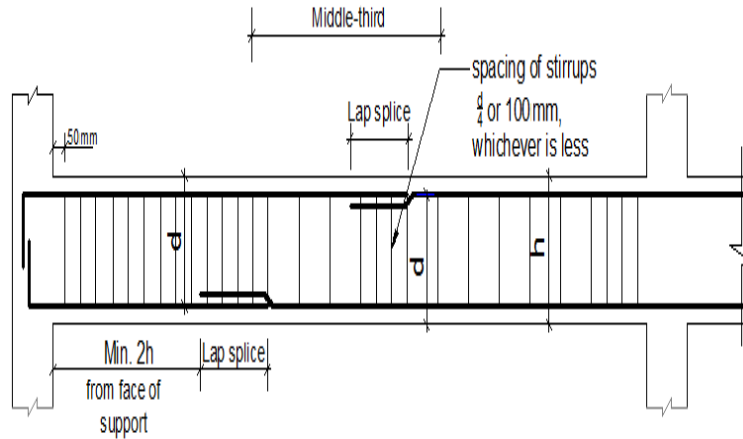


Figure 6.8.1. General requirement for flexural members of special moment frames (Sec 8.3.4.1)



Note: Transverse reinforcement not shown for clarity

Figure 6.8.2 Flexural Requirements for Flexural Members of Special Moment Frames (Sec 8.3.4.2)



Notes: (i) For beam bottom bars lap shall not be provided within a distance of twice the member depth from the face of the support; (ii) Preferred lap location of top bar is within middle third of the span but may be provided beyond $2h$ from the face of the support; (iii) Not more than 50% of the bars shall be spliced at one location; (iv) Lap splices are to be confined by stirrups with maximum spacing $d/4$ or 100 mm whichever is smaller.

Figure 6.8.3 Lap splice requirements for flexural members of special moment frames (Sec 8.3.4.2)

8.3.4.3 Transverse reinforcement

- (a) Hoops shall be provided in the following regions of frame members:
 - (i) At both ends of the flexural member, over a length equal to twice the member depth measured from the face of the supporting member toward midspan (Figure 6.8.4).
 - (ii) Over lengths equal to twice the member depth (Figure 6.8.4), on both sides of a section where flexural yielding is likely to occur in connection with inelastic lateral displacements of the frame.
- (b) The first hoop shall be located not more than 50 mm from the face of the supporting member (Figure 6.8.4). Maximum spacing of the hoops shall not exceed (i) $\frac{d}{4}$ (ii) eight times the diameter of the smallest longitudinal bars, (iii) 24 times the diameter of the hoop bars, and (iv) 300 mm.
- (c) Where hoops are required, longitudinal bars on the perimeter shall have lateral support conforming to 8.1.9.4(c), and where hoops are not required, stirrups with seismic hooks shall be spaced not more than $\frac{d}{2}$ throughout the length of the member (Figure 6.8.4).

- (d) Hoops in flexural members are allowed to be made up of two pieces of reinforcement consisting of a U-stirrup having hooks not less than 135° with 6 diameter but not less than 75 mm extension anchored in the confined core and a cross tie to make a closed hoop (Figure 6.8.5). Consecutive cross ties engaging the same longitudinal bar shall have their 90° hooks at opposite sides of the flexural member. If the longitudinal reinforcing bars secured by the cross ties are confined by a slab only on one side of the flexural frame member, the 90° hooks of the cross ties shall all be placed on that side.

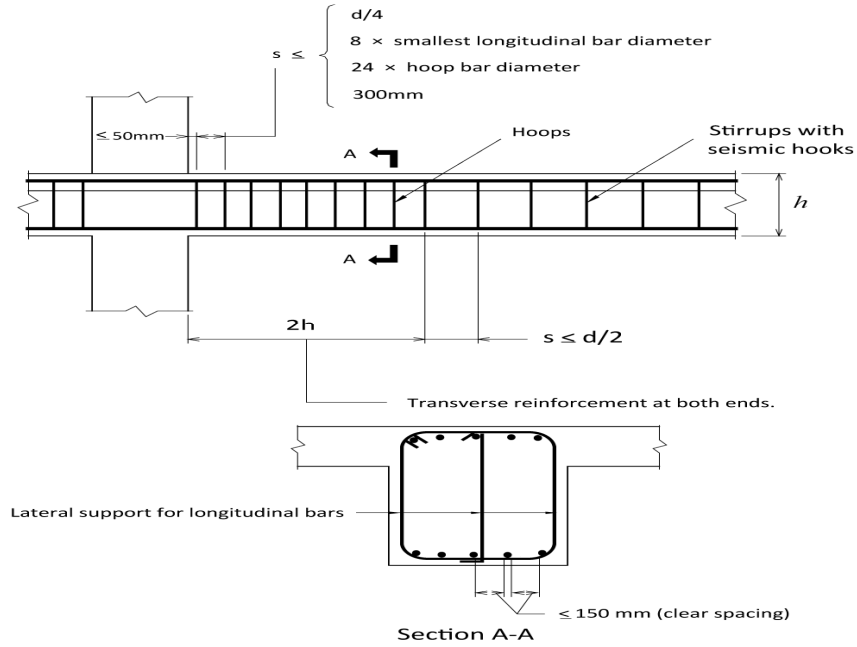


Figure 6.8.4 Transverse Reinforcement Requirements for Flexural Members of Special Moment Frames (Sec 8.3.4.3)

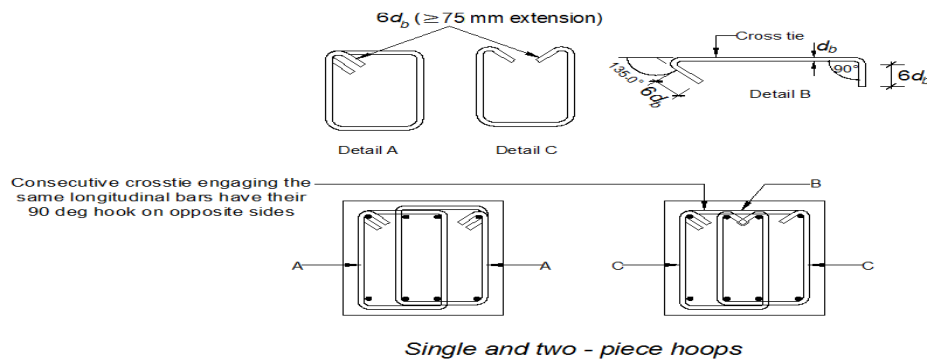


Figure 6.8.5 Hoop Reinforcement Requirements for Flexural Members of Special Moment Frames (Sec 8.3.4.3)

8.3.5 Special Moment Frame Members Subjected to Bending and Axial Load

8.3.5.1 Scope

The requirements of this section shall apply to columns and other frame members serving to resist earthquake forces and having a factored axial force exceeding $0.1A_g f'_c$. These frame members shall also satisfy the following conditions. The requirements are also shown in Figure 6.8.6.

- (a) The shortest cross-sectional dimension shall not be less than 300 mm.
- (b) The ratio of the shortest cross-sectional dimension to the perpendicular dimension shall not be less than 0.4.

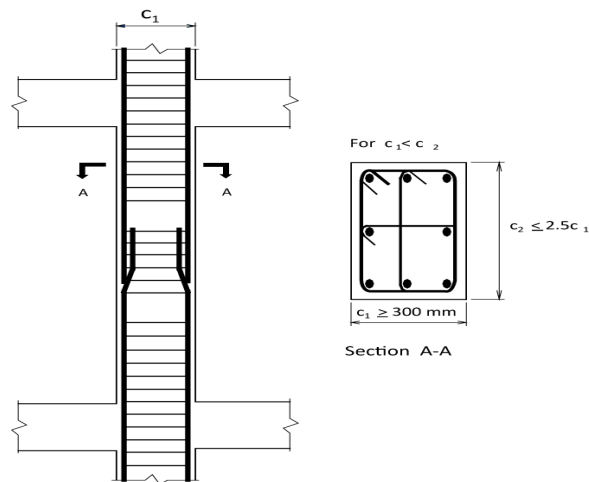


Figure 6.8.6 General requirements for special moment frames subjected to bending and axial load (Sec 8.3.5.1)

8.3.5.2 Minimum flexural strength of columns

- (a) Flexural strength of any column designed to resist a factored axial compressive force exceeding $0.1A_g f'_c$ shall satisfy (b) or (c) below. Lateral strength and stiffness of columns not satisfying (b) below shall be ignored in calculating the strength and stiffness of the structure but shall conform to Sec 8.3.9.
- (b) The flexural strength of the columns shall satisfy the following relation:

$$\sum M_c \geq 1.2 \sum M_g \quad (6.8.5)$$

Where,

$\sum M_c$ = sum of nominal flexural strengths of columns framing into the joint, evaluated at the face of the joint. Column flexural strength shall be calculated for the factored axial force, consistent with the direction of lateral forces considered, resulting in the lowest flexural strength.

$\sum M_g$ = sum of nominal flexural strength of the beams framing into the joint evaluated at the face of the joint.

Flexural strengths shall be summed such that the column moments oppose the beam moments. Eq. 6.8.5 shall be satisfied for beam moments acting in both directions in the vertical plane of the frame considered.

- (c) If the requirements of (b) above is not satisfied at a joint, columns supporting reactions from that joint shall be provided with transverse reinforcement as specified in Sec 8.3.5.4 over their entire height.

8.3.5.3 Longitudinal reinforcement

The provisions of longitudinal reinforcement are as shown in Figure 6.8.7 and stated as under.

- (a) The reinforcement ratio, ρ_g shall not be less than 0.01 and shall not exceed 0.06.
- (b) Lap splices are permitted only within the centre half of the member length and shall be designed as tension splices. Welded splices and mechanical connections conforming to Sections 8.2.12.3(a) to 8.2.12.3(d) are allowed for splicing the reinforcement at any section provided not more than alternate longitudinal bars are spliced at a section and the distance between splices is 600 mm or more along the longitudinal axis of the reinforcement.

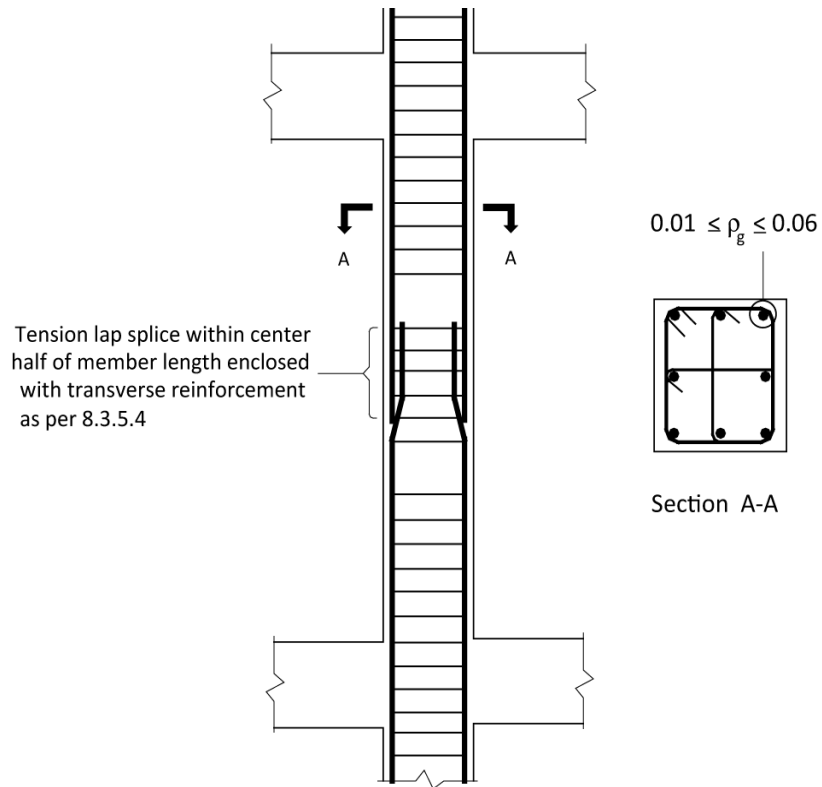


Figure 6.8.7 Longitudinal reinforcement requirements (SMF) (Sec 8.3.5.3)

8.3.5.4 Transverse reinforcement

- (a) Transverse reinforcement shall be provided as specified below and shown in Figures 6.8.8 and 6.8.9 unless a larger amount is required by Sec 8.3.8.

- (i) The volumetric ratio of spiral or circular hoop reinforcement, ρ_s shall not be less than that indicated by the following equation:

$$\rho_s = \frac{0.12f'_c}{f_{yt}} \quad (6.8.6)$$

and shall not be less than that required by Eq. (6.6.12).

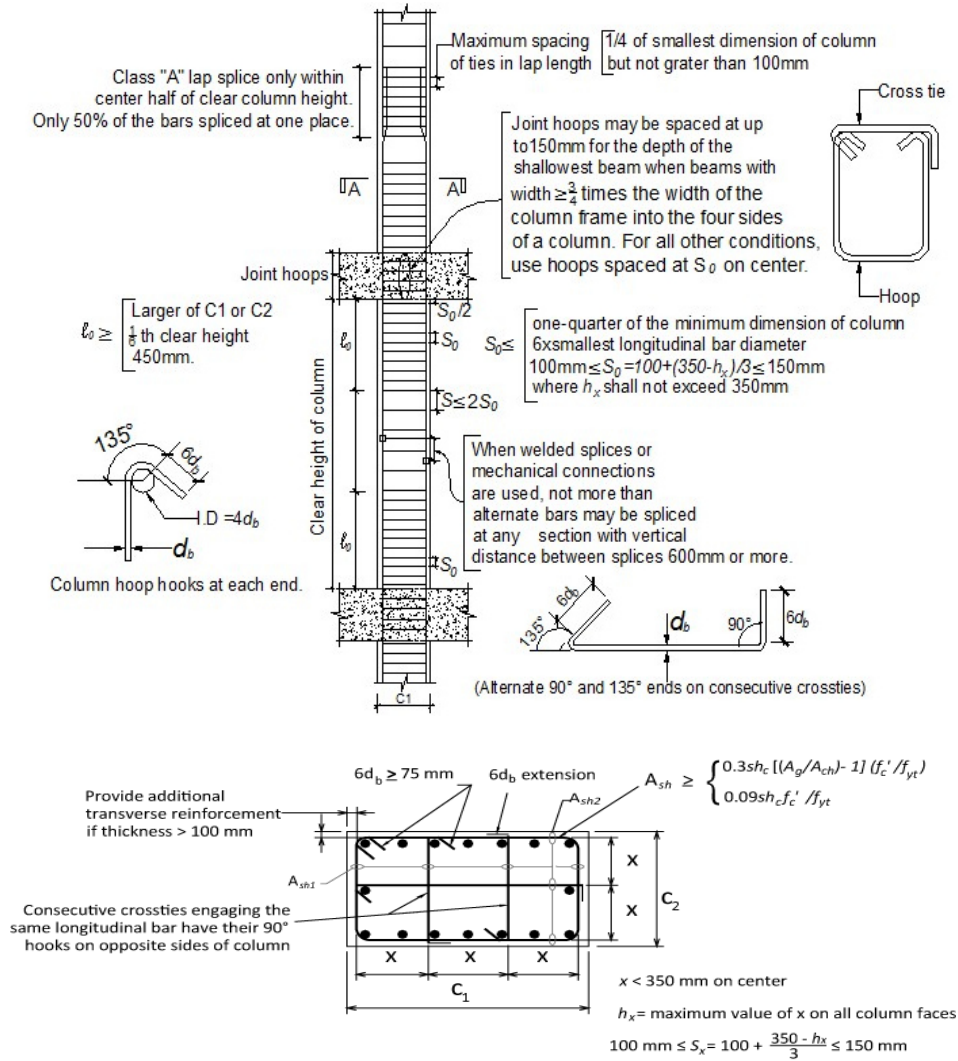
- (ii) The total cross-sectional area of rectangular hoop reinforcement shall not be less than that given by the following equations:

$$A_{sh} = 0.3 \left(\frac{shcf'_c}{f_{yt}} \right) \left(\frac{A_g}{A_{ch}} - 1 \right) \quad (6.8.7)$$

$$A_{sh} = 0.09 \left(\frac{shcf'_c}{f_{yt}} \right) \quad (6.8.8)$$

-
- (iii) Transverse reinforcement shall be provided by either single or overlapping hoops or cross ties of the same bar size and spacing. Each end of the cross ties shall engage a peripheral longitudinal reinforcing bar. Consecutive cross ties shall be alternated end for end along the longitudinal reinforcement.
- (iv) If the design strength of member core satisfies the requirements of the specified loading combinations including earthquake effect, Eq. 6.8.7 and Eq. 6.6.12 need not be satisfied.
- (b) Spacing of transverse reinforcement along the length l_o of the member shall not exceed the smallest of (i) one-quarter of the minimum dimension (ii) six times the diameter of the smallest longitudinal bar and (iii) $s_o = 100 + \frac{(350-h_x)}{3}$. The value of s_o shall not exceed 150 mm and need not be taken less than 100 mm.
- (c) Spacing of cross ties or legs of overlapping hoops shall not be more than 350 mm on centre in the direction perpendicular to the longitudinal axis of the member.
- (d) The volume of transverse reinforcement in amount specified in (a) through (c) above shall be provided over a length l_o from each joint face and on both sides of any section where flexural yielding is likely to occur in connection with inelastic lateral displacements of the frame. The length l_o shall not be less than (i) the depth of the member at the joint face or at the section where flexural yielding is likely to occur, (ii) one-sixth of the clear span of the member, and (iii) 450 mm.
- (e) If the factored axial force in columns supporting reactions from discontinued stiff members, such as walls, exceeds $0.1A_gf'_c$ they shall be provided with transverse reinforcement as specified in (a) through (c) above over their full height beneath the level at which the discontinuity occurs. Transverse reinforcement shall extend into the discontinued member for at least the development length of the largest longitudinal reinforcement in the column in accordance with Sec 8.3.7.4. If the lower end of the column terminates on a wall, transverse reinforcement as specified above shall extend into the wall for at least the development length of the largest longitudinal reinforcement in the column at the point of termination. If the column terminates on a footing or mat, transverse reinforcement as specified in above shall extend at least 300 mm into the footing or mat.

- (f) Where transverse reinforcement as specified in (a) through (c) above, is not provided throughout the full length of the column, the remainder of the column length shall contain spiral or hoop reinforcement with centre to centre spacing not exceeding the smaller of 6 times the diameter of the longitudinal column bars or 150 mm.



Note: In beam column joints where members frame into all four sides of the joint and each member width is at least three-fourths the column width, the spacing of transverse reinforcement shall be 150 mm within the overall depth of the shallowest frame member. For all other conditions spacing shall be S_0 . Use hoops and cross ties in beam column joint.

Figure 6.8.8 Transverse reinforcement requirements- rectangular hoop for members subjected to bending and axial load rectangular hoop (SMF) (Sec 8.3.5.4)

8.3.6 Special Structural Walls and Coupling Beams

8.3.6.1 Scope: Requirements of Sec 8.3.6 apply to special structural walls and all components of special structural walls including coupling beams and wall piers forming part of the seismic-force-resisting system.

8.3.6.2 Reinforcement

- (a) The distributed web reinforcement ratios, ρ_l and ρ_t , for structural walls shall not be less than 0.0025, except that if V_u does not exceed $0.083A_{cv}\lambda\sqrt{f'_c}$, ρ_l and ρ_t shall be permitted to be reduced to the values required as specified below. Reinforcement spacing each way in structural walls shall not exceed 450 mm. Reinforcement contributing to V_n shall be continuous and shall be distributed across the shear plane.
- (i) Minimum ratio of vertical reinforcement area to gross concrete area, ρ_v , shall be:
- | | |
|---|--------|
| Deformed bar not larger than 16 mm diameter with f_y not less than 420 MPa: | 0.0012 |
| Other deformed bars: | 0.0015 |
| Welded wire reinforcement not larger than ASTM MW 200 or MD 200: | 0.0012 |
- (ii) Minimum ratio of horizontal reinforcement area to gross concrete area, ρ_h , shall be:
- | | |
|---|--------|
| Deformed bar not larger than 16 mm diameter with f_y not less than 420 MPa: | 0.0020 |
| Other deformed bars: | 0.0025 |
| Welded wire reinforcement not larger than ASTM MW 200 or MD 200: | 0.0020 |
- (b) At least two curtains of reinforcement shall be used in a wall if V_u exceeds $0.17A_{cv}\lambda\sqrt{f'_c}$.
- (c) Reinforcement in structural walls shall be developed or spliced for f_y in tension in accordance with Sec 8.2, except:
- (i) The effective depth of the member shall be permitted to be taken as $0.8l_w$ for walls where, reinforcement extended beyond the point at which it is no longer required to resist flexure for a distance equal to d or $12d_b$, whichever is greater, except at supports of simple spans and at free end of cantilevers.
- (ii) The requirements of Sections 8.2.8, 8.2.9, and 8.2.10 need not be satisfied.

At locations where yielding of longitudinal reinforcement is likely to occur as a result of lateral displacements, development lengths of longitudinal reinforcement shall be 1.25 times the values calculated for f_y in tension.

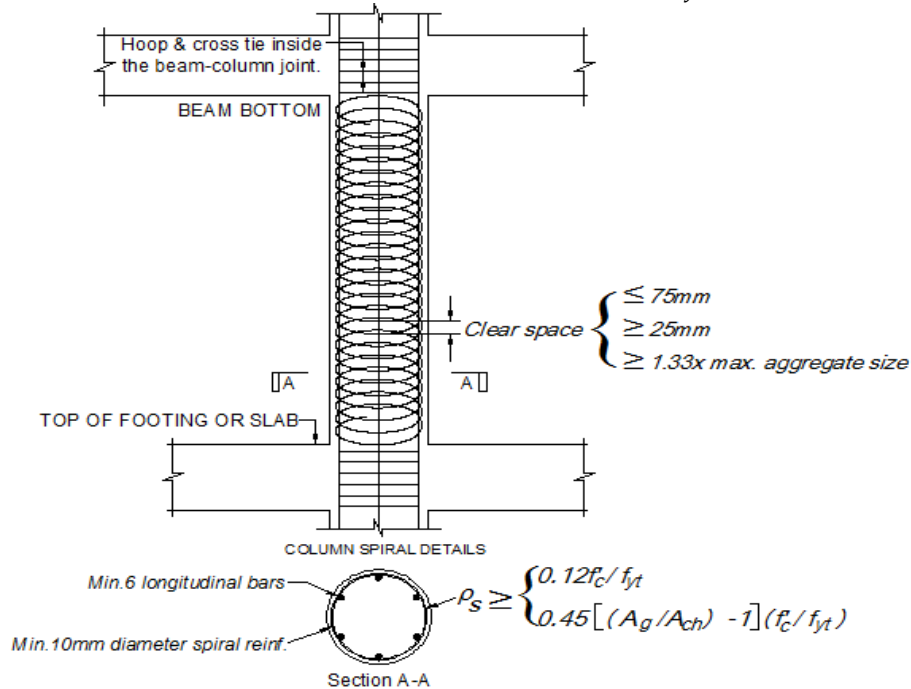


Figure 6.8.9 Transverse reinforcement requirements- spiral hoop (SMF) (Sections 8.1.9.3, 8.3.7.2)

8.3.6.3 Design forces: V_u shall be obtained from the lateral load analysis in accordance with the factored load combinations.

8.3.6.4 Shear strength

(a) V_n of structural walls shall not exceed

$$V_n = A_{cv}(\alpha_c \lambda \sqrt{f'_c} + \rho_t f_y) \quad (6.8.9)$$

Where, the coefficient α_c is 0.25 for $h_w/l_w \leq 1.5$, is 0.17 for $h_w/l_w \geq 2.0$, and varies linearly between 0.25 and 0.17 for h_w/l_w between 1.5 and 2.0.

(b) In Sec 8.3.6.4(a), the value of ratio h_w/l_w used for determining V_n for segments of a wall shall be the larger of the ratios for the entire wall and the segment of wall considered.

(c) Walls shall have distributed shear reinforcement providing resistance in two orthogonal directions in the plane of the wall. If h_w/l_w does not exceed 2.0, reinforcement ratio ρ_l shall not be less than reinforcement ratio ρ_t .

- (d) For all vertical wall segments resisting a common lateral force, combined V_n shall not be taken larger than $0.66A_{cv}\sqrt{f'_c}$, where, A_{cv} is the gross combined area of all vertical wall segments. For any one of the individual vertical wall segments, V_n shall not be taken larger than $0.83A_{cw}\sqrt{f'_c}$, where A_{cw} is the area of concrete section of the individual vertical wall segment considered.
- (e) For horizontal wall segments as shown in Figure 6.8.10, including coupling beams, V_n shall not be taken larger than $0.83A_{cw}\sqrt{f'_c}$, where A_{cw} is the area of concrete section of a horizontal wall segment or coupling beam.

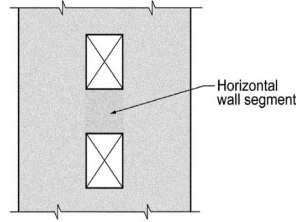


Figure 6.8.10 Wall with openings

8.3.6.5 Design for flexure and axial loads

- (a) Structural walls and portions of such walls subject to combined flexural and axial loads shall be designed in accordance with Sections 6.3.2 and 6.3.3 except that Sec 6.3.3.7 and the nonlinear strain requirements of Sec 6.3.2.2 shall not apply. Concrete and developed longitudinal reinforcement within effective flange widths, boundary elements, and the wall web shall be considered effective. The effects of openings shall be considered.
- (b) Unless a more detailed analysis is performed, effective flange widths of flanged sections shall extend from the face of the web a distance equal to the smaller of one-half the distance to an adjacent wall web and 25 percent of the total wall height.

8.3.6.6 Boundary elements of special structural walls

- (a) The need for special boundary elements at the edges of structural walls shall be evaluated in accordance with Sec 8.3.6.6(b) or (c). The requirements of Sec 8.3.6.6(d) and (e) also shall be satisfied.

- (b) This section applies to walls or wall piers that are effectively continuous from the base of structure to top of wall and designed to have a single critical section for flexure and axial loads. Walls not satisfying these requirements shall be designed by Sec 8.3.6.6(c).

- (i) Compression zones shall be reinforced with special boundary elements where

$$c \geq \frac{l_w}{600(\delta_u/h_w)} \quad (6.8.10)$$

In Eq. 6.8.10, c corresponds to the largest neutral axis depth calculated for the factored axial force and nominal moment strength consistent with the design displacement δ_u . Ratio $\frac{\delta_u}{h_w}$ in Eq. 6.8.10 shall not be taken less than 0.007;

- (ii) Where special boundary elements are required by b(i), the special boundary element reinforcement shall extend vertically from the critical section a distance not less than the larger of l_w or $\frac{M_u}{4V_u}$.

- (c) Structural walls not designed to the provisions of (b) shall have special boundary elements at boundaries and edges around openings of structural walls where the maximum extreme fiber compressive stress, corresponding to load combinations including earthquake effects, E , exceeds $0.2f'_c$. The special boundary element shall be permitted to be discontinued where the calculated compressive stress is less than $0.15f'_c$. Stresses shall be calculated for the factored forces using a linearly elastic model and gross section properties. For walls with flanges, an effective flange width as defined in Sec 8.3.6.5(b) shall be used.

- (d) Where special boundary elements are required by Sec 8.3.6.6(b) or (c), following (i) to (v) shall be satisfied as shown in Figure 6.8.11:

- (i) The boundary element shall extend horizontally from the extreme compression fiber a distance not less than the larger of $c - 0.1l_w$ and $\frac{c}{2}$, where c is the largest neutral axis depth calculated for the factored axial force and nominal moment strength consistent with δ_u ;
- (ii) In flanged sections, the boundary element shall include the effective flange width in compression and shall extend at least 300 mm into the web;
- (iii) The boundary element transverse reinforcement shall satisfy the requirements of Sec 8.3.5.4 as shown in Figure 6.8.8, except Eq. 6.8.7 need not be satisfied and the transverse reinforcement spacing limit of 8.3.5.4.b(i) shall be one-third of the least dimension of the boundary element;

- (iv) The boundary element transverse reinforcement at the wall base shall extend into the support at least l_d according to Sec 8.3.6.2(c), of the largest longitudinal reinforcement in the special boundary element unless the special boundary element terminates on a footing, mat, or pile cap, where special boundary element transverse reinforcement shall extend at least 300 mm into the footing, mat, or pile cap;
- (v) Horizontal reinforcement in the wall web shall extend to within 150 mm of the end of the wall. Reinforcement shall be anchored to develop f_y in tension within the confined core of the boundary element using standard hooks or heads. Where the confined boundary element has sufficient length to develop the horizontal web reinforcement, and $\frac{A_v f_y}{S}$ of the web reinforcement is not greater than $\frac{A_{sh} f_{yt}}{S}$ of the boundary element transverse reinforcement parallel to the web reinforcement, it shall be permitted to terminate the web reinforcement without a standard hook or head.
- (e) Where special boundary elements are not required by Sec 8.3.6.6(b) or (c), (i) and (ii) shall be satisfied as shown in Figure 6.8.12:
 - (i) If the longitudinal reinforcement ratio at the wall boundary is greater than $\frac{2.8}{f_c}$, boundary transverse reinforcement shall satisfy Sec 8.3.5.4.(a).(iii), Sec 8.3.5.4.(c) as shown in Figure 6.8.8 and Sec 8.3.6.6.(d).(i). The maximum longitudinal spacing of transverse reinforcement in the boundary shall not exceed 200 mm;
 - (ii) Except when V_u in the plane of the wall is less than $0.083A_{cv}\lambda\sqrt{f'_c}$, horizontal reinforcement terminating at the edges of structural walls without boundary elements shall have a standard hook engaging the edge reinforcement or the edge reinforcement shall be enclosed in U-stirrups having the same size and spacing as, and spliced to, the horizontal reinforcement.

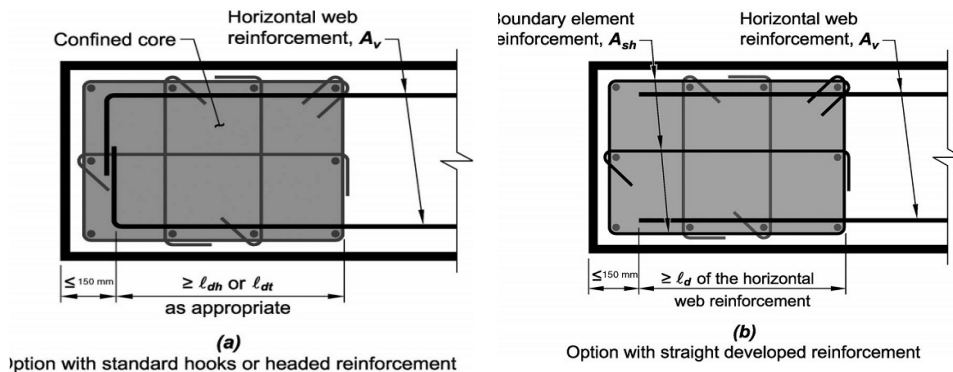


Figure 6.8.11 Development of wall horizontal reinforcement in confined boundary element

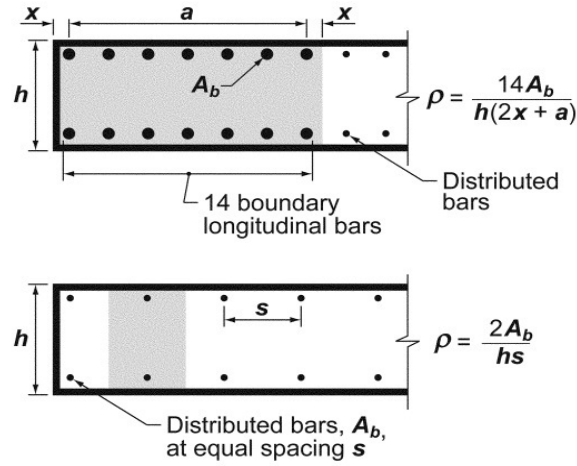


Figure 6.8.12 Longitudinal reinforcement ratios for typical wall boundary conditions.

8.3.6.7 Coupling beams

- (a) Coupling beams with $\frac{l_n}{h} > 4$ shall satisfy the requirements of Sec 8.3.7. The provisions of Sec 8.3.7.1(c) and (d) need not be satisfied if it can be shown by analysis that the beam has adequate lateral stability.
- (b) Coupling beams with $\frac{l_n}{h} < 2$ and with V_u exceeding $0.33A_{cw}\lambda\sqrt{f'_c}$, shall be reinforced with two intersecting groups of diagonally placed bars symmetrical about the midspan, unless it can be shown that loss of stiffness and strength of the coupling beams will not impair the vertical load-carrying ability of the structure, the egress from the structure, or the integrity of nonstructural components and their connections to the structure.
- (c) Coupling beams not governed by Sec 8.3.6.7(a) or (b) shall be permitted to be reinforced either with two intersecting groups of diagonally placed bars symmetrical about the midspan or according to Sections 8.3.7.2 to 8.3.7.4.
- (d) Coupling beams reinforced with two intersecting groups of diagonally placed bars symmetrical about the midspan shall satisfy (i), (ii), and either (iii) or (iv). Requirements of Sec 6.4.5 Chapter 6 shall not apply.
 - (i) V_n shall be determined by

$$V_n = 2A_{vd}f_y\sin\alpha \leq 0.83A_{cw}\sqrt{f'_c} \quad (6.8.11)$$

Where, α is the angle between the diagonal bars and the longitudinal axis of the coupling beam.

- (ii) Each group of diagonal bars shall consist of a minimum of four bars provided in two or more layers. The diagonal bars shall be embedded into the wall not less than 1.25 times the development length for f_y in tension.
- (iii) Each group of diagonal bars shall be enclosed by transverse reinforcement having out-to-out dimensions not smaller than $\frac{b_w}{2}$ in the direction parallel to b_w and $\frac{b_w}{5}$ along the other sides, where b_w is the web width of the coupling beam. The transverse reinforcement shall satisfy Sec 8.3.5.4 as shown in Figure 6.8.8 and shall have spacing measured parallel to the diagonal bars satisfying Sec 8.3.5.4 and not exceeding six times the diameter of the diagonal bars, and shall have spacing of crossties or legs of hoops measured perpendicular to the diagonal bars not exceeding 350 mm. For the purpose of computing A_g for use in Figure 6.8.9 and Eq. 6.8.7, the concrete cover as required in Sec 8.1.7 shall be assumed on all four sides of each group of diagonal bars. The transverse reinforcement, or its alternatively configured transverse reinforcement satisfying the spacing and volume ratio requirements of the transverse reinforcement along the diagonals, shall continue through the intersection of the diagonal bars. Additional longitudinal and transverse reinforcement shall be distributed around the beam perimeter with total area in each direction not less than $0.002b_w s$ and spacing not exceeding 300 mm as shown in Figure 6.8.13(a).
- (iv) Transverse reinforcement shall be provided for the entire beam cross section satisfying Sec 8.3.5.4 as shown in Figure 6.8.8, with longitudinal spacing not exceeding the smaller of 150 mm and six times the diameter of the diagonal bars, and with spacing of crossties or legs of hoops both vertically and horizontally in the plane of the beam cross section not exceeding 200 mm. Each crosstie and each hoop leg shall engage a longitudinal bar of equal or larger diameter. It shall be permitted to configure hoops as shown in Figure 6.8.13(b).

8.3.6.8 Wall piers

- (a) Wall piers shall satisfy the special moment frame requirements for columns of Sec 8.3.5.3 with joint faces taken as the top and bottom of the clear height of the wall pier. Alternatively, wall piers with $\frac{h_w}{b_w} > 2.5$ shall satisfy (i) to (vi) below:
- (i) Design shear force shall be determined in accordance with Sec 8.3.8.1 with joint faces taken as the top and bottom of the clear height of the wall pier. Where the Code includes provisions to account for overstrength of the seismic-force-resisting system, the design shear force need not exceed Ω_o times the factored shear determined by analysis of the structure for earthquake effects.

- (ii) V_n and distributed shear reinforcement shall satisfy Sec 8.3.6.4.
 - (iii) Transverse reinforcement shall be in the form of hoops except it shall be permitted to use single-leg horizontal reinforcement parallel to l_w , where only one curtain of distributed shear reinforcement is provided. Single-leg horizontal reinforcement shall have 180° bends at each end that engage wall pier boundary longitudinal reinforcement.
 - (iv) Vertical spacing of transverse reinforcement shall not exceed 150 mm.
 - (v) Transverse reinforcement shall extend at least 300 mm above and below the clear height of wall pier.
 - (vi) Special boundary elements shall be provided if required by Sec 8.3.6.6(c).
- (b) For wall piers at the edge of a wall, horizontal reinforcement shall be provided in adjacent wall segments above and below the wall pier and be proportioned to transfer the design shear force from the wall pier into the adjacent wall segments as shown in Figure 6.8.14.

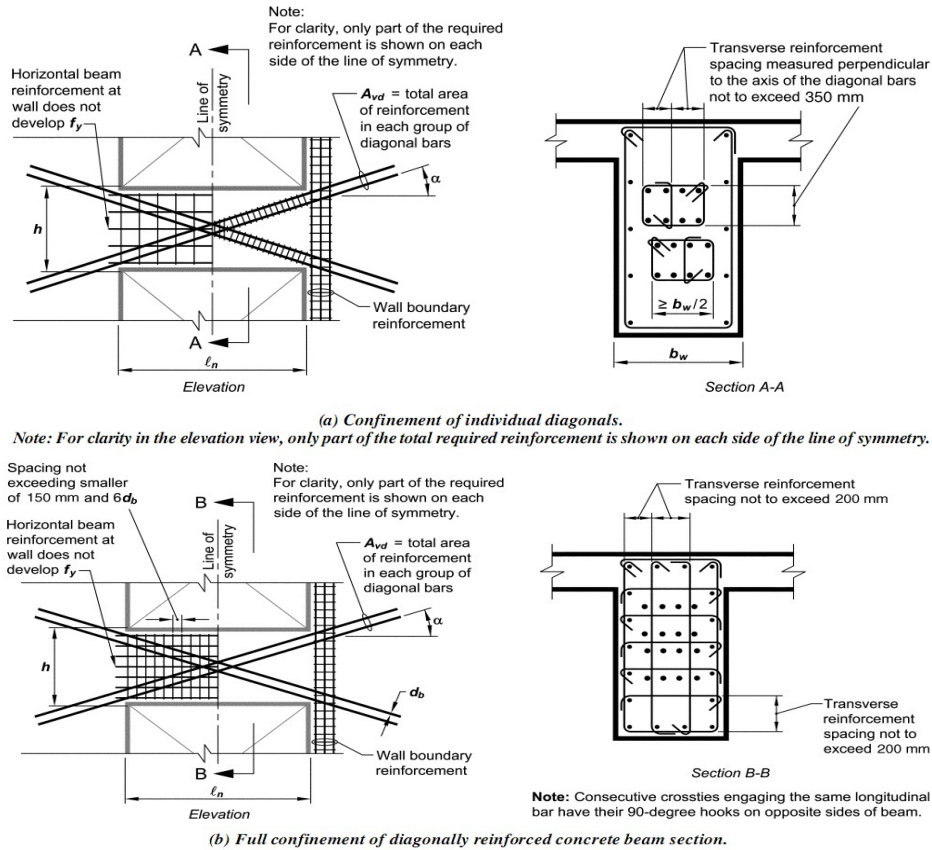


Figure 6.8.13 Coupling beams with diagonally oriented reinforcement. Wall Boundary reinforcement shown on one side only for clarity.

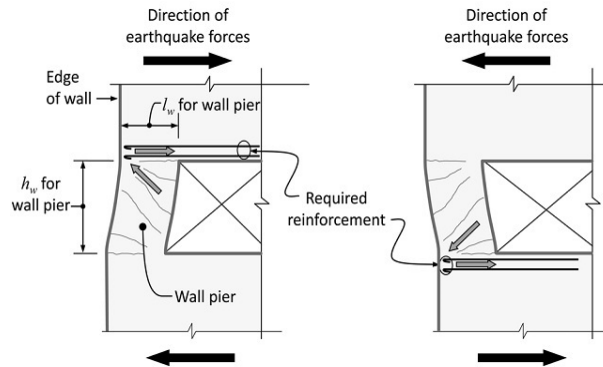


Figure 6.8.14 Required horizontal reinforcement in wall segments above and below wall piers at the edge of a wall.

8.3.6.9 Construction joints: All construction joints in structural walls shall conform to Sec 5.16.4 and contact surfaces shall be roughened as in Sec 6.4.5.9.

8.3.6.10 Discontinuous walls: Columns supporting discontinuous structural walls shall be reinforced in accordance with Sec 8.3.5.4(e).

8.3.7 Joints of Special Moment Frames

8.3.7.1 General requirements

- (a) Forces in longitudinal beam reinforcement at the faces of joints of reinforced concrete frames shall be determined for a stress of $1.25f_y$ in the reinforcement.
- (b) Joint strength shall be calculated by the appropriate strength reduction factors specified in Sec 6.2.3.1.
- (c) Beam longitudinal reinforcement terminated in a column shall be extended to the far face of the confined column core and anchored in tension as per Sec 8.3.7.4 below and in compression according to Sec 8.2.
- (d) Where longitudinal beam reinforcement extends through a beam-column joint, the column dimension parallel to the beam reinforcement shall not be less than 20 times the diameter of the largest longitudinal beam bar for normal-weight concrete. For light-weight concrete, the dimension shall not be less than 26 times the bar diameter.

8.3.7.2 Transverse reinforcement

The provisions of transverse reinforcement are shown in Figures 6.8.15 and 6.8.16, stated as under.

- As specified in Sec 8.3.5.4, transverse hoop reinforcement shall be provided within the joint, unless the joint is confined by structural members as specified in (b) below.
- Within the depth of the shallowest framing member, transverse reinforcement equal to at least one-half the amount required by Sec 8.3.5.4(a) shall be provided where members frame into all four sides of the joint and where each member width is at least three-fourths the column width. At these locations, the spacing specified in Sec 8.3.5.4(b) may be increased to 150 mm.
- As required by Sec 8.3.5.4, transverse reinforcement shall be provided through the joint to provide confinement for longitudinal beam reinforcement outside the column core if such confinement is not provided by a beam framing into the joint.

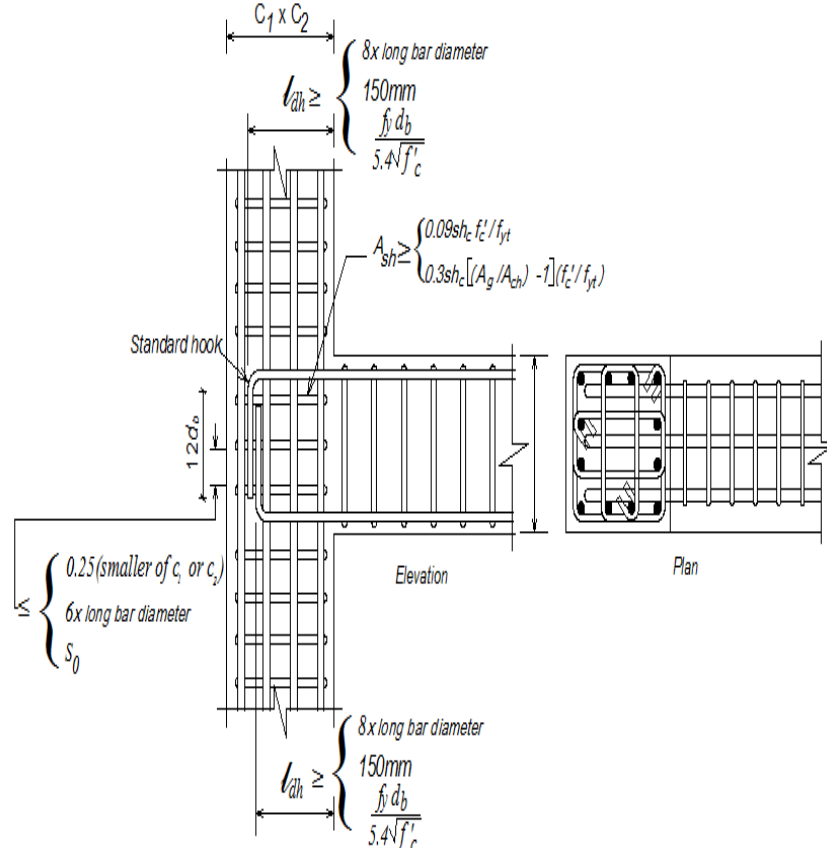


Figure 6.8.15 General requirements and transverse reinforcement requirements for joints not confined by structural member

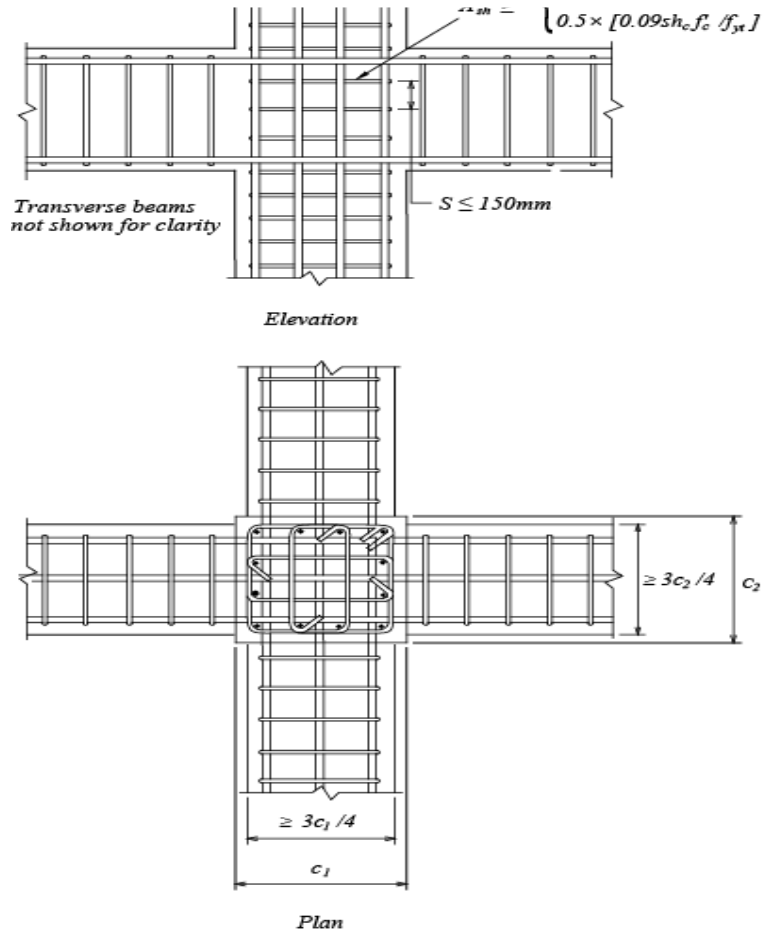


Figure 6.8.16 Transverse reinforcement requirements for joints confined by structural member

8.3.7.3 Shear Strength

The nominal shear strength for the joint shall be taken not greater than the forces specified below:

Joints confined on all four faces: $1.7\sqrt{f'_c} A_j$

Joints confined on three faces or on two opposite faces: $1.2\sqrt{f'_c} A_j$

Others: $1.0\sqrt{f'_c} A_j$

A member that frames into a face is considered to provide confinement to the joint if at least three-quarters of the face of the joint is covered by the framing member. A joint is considered to be confined if such confining members frame into all faces of the joint.

8.3.7.4 Development length of bars in tension

- (a) The development length, l_{dh} , for bar sizes 10 mm to 36 mm in diameter with a standard 90° hook shall be not less than (i) $8d_b$, (ii) 150 mm, and (iii) the length required by Eq. 6.8.9.

$$l_{dh} = \frac{f_y d_b}{5.4 \sqrt{f'_c}} \quad (6.8.12)$$

For light-weight concrete, l_{dh} for a bar with a standard 90° hook shall not be less than (i) $10d_b$, (ii) 190 mm, and (iii) 1.25 times the length required by Eq. 6.8.12. The 90° hook shall be located within the confined core of a column or a boundary element.

- (b) For bar sizes 10 mm to 36 mm diameter, the development length, l_d for a straight bar shall be not less than (i) 2.5 times the length required by (a) above, if the depth of the concrete cast in one lift beneath the bar does not exceed 300 mm, and (ii) 3.5 times the length required by (a) above, if the depth of the concrete cast in one lift beneath the bar exceeds 300 mm.
- (c) Straight bars terminated at a joint shall pass through the confined core of a column or of a boundary member. Any portion of the straight embedment length not within the confined core shall be increased by a factor of 1.6.

8.3.8 Shear Strength Requirements**8.3.8.1** Design forces

- (a) Frame Members Subjected Primarily to Bending: The design shear force V_e shall be determined from consideration of the maximum forces that can be generated at the faces of the joints at each of the member. It shall be assumed that moments of opposite sign corresponding to probable strength M_{pr} act at the joint faces, and that the member is loaded with the factored tributary gravity load along its span.
- (b) Frame Members Subjected to Combined Bending and Axial Load: The design shear force V_e shall be determined from consideration of the maximum forces that can be generated at the faces of the joints at each end of the member. These joint forces shall be determined using the maximum probable moment strengths M_{pr} of the member associated with the range of factored axial loads on the member. The member shears need not exceed those determined from joint strengths based on the probable moment strength M_{pr} of the transverse members framing into the joint. In no case, V_e shall be less than the factored shear determined by the analysis of the structure.

- (c) Structural Walls and Diaphragms: The design shear force V_e shall be obtained from the lateral load analysis in accordance with the factored loads and combinations specified in Chapter 2, loads.

8.3.8.2 Transverse reinforcement in frame members

- (a) For determining the required transverse reinforcement in frame members, the quantity V_c shall be assumed to be zero if the factored axial compressive force including earthquake effects is less than $0.05A_g f'_c$ when the earthquake-induced shear forces, calculated in accordance with Sec 8.3.8.1(a), represents one-half or more of total design shear.
- (b) Stirrups or ties required to resist shear shall be closed hoops over lengths of members as specified in Sections 8.3.4.3, 8.3.5.4 and 8.3.7.2.

8.3.8.3 Shear strength of special structural walls and diaphragms

- (a) Nominal shear strength of structural walls and diaphragms shall be determined using either (b) or (c) below.
- (b) Nominal shear strength, V_n of structural walls and diaphragms shall be assumed not to exceed the shear force calculated from

$$V_n = A_{cv}(0.17\lambda\sqrt{f'_c} + \rho_n f_y) \quad (6.8.13)$$

- (c) For walls and wall segments having a ratio of $\frac{h_w}{l_w}$ less than 2.0, nominal shear strength of wall and diaphragm shall be determined from

$$V_n = A_{cv}(\alpha_c \lambda \sqrt{f'_c} + \rho_n f_y) \quad (6.8.14)$$

Where the coefficient α_c is 0.25 for $\frac{h_w}{l_w} \leq 1.5$, is 0.17 for $\frac{h_w}{l_w} \geq 2.0$, and varies linearly between 0.25 and 0.17 for $\frac{h_w}{l_w}$ between 1.5 and 2.0.

- (d) Value of ratio $\frac{h_w}{l_w}$ used in (c) above for determining V_n for segments of a wall or diaphragm shall be the larger of the ratios for the entire wall (diaphragm) and the segment of wall (diaphragm) considered.
- (e) Walls and diaphragms shall have distributed shear reinforcement providing resistance in two orthogonal directions in the plane of the wall. If the ratio $\frac{h_w}{l_w}$ does not exceed 2.0, reinforcement ratio, ρ_v shall not be less than reinforcement ratio ρ_n .

- (f) Nominal shear strength of all wall piers sharing a common lateral force shall not be assumed to exceed $0.67A_{cv}\sqrt{f'_c}$, where A_{cv} is the total cross-sectional area, and the nominal shear strength of any one of the individual wall piers shall not be assumed to exceed $0.83A_{cp}\sqrt{f'_c}$

Where A_{cp} represents the cross-sectional area of the pier considered.

- (g) Nominal shear strength of horizontal wall segments shall be assumed not to exceed $0.83A_{cp}\sqrt{f'_c}$ where A_{cp} represents the cross-sectional area of a horizontal wall segment.

8.3.9 Ordinary Moment Frame Members not Proportioned to Resist Forces Induced by Earthquake Motion

8.3.9.1 Induced moments

Frame members assumed not to contribute to lateral resistance shall be detailed according to (a) or (b) below depending on the magnitude of moments induced in those members when subjected to twice the lateral displacement under the factored lateral forces.

- (a) Members with factored gravity axial forces not exceeding $0.1A_gf'_c$ shall satisfy Sections 8.3.4.2(a) and 8.3.8.1(a) and members with factored gravity axial forces exceeding $0.1A_gf'_c$ shall satisfy Sections 8.3.5.4, 8.3.7.2(a) and 8.3.8.1(b) when the induced moment exceeds the design moment strength of the frame member.
- (b) The member shall satisfy Sec 8.3.4.2(a) when the induced moment does not exceed the design moment strength of the frame members.

8.3.9.2 Tie requirements

All frame members with factored axial compressive forces exceeding $0.1A_gf'_c$ shall satisfy the following special requirements unless they comply with Sec 8.3.5.4.

- (a) Ties shall have hooks not less than 135° with extensions not less than 6 tie bar diameter or 60 mm. Cross ties as defined in Sec 8.3.2 are allowed.
- (b) The maximum tie spacing shall be s_0 over a length l_0 measured from the joint face. The spacing s_0 shall be not more than (i) eight diameters of the smallest longitudinal bar enclosed, (ii) 24 tie bar diameters, and (iii) one-half the least cross-sectional dimension of the column. The length l_0 shall not be less than (i) one-sixth of the clear height of the column, (ii) the maximum cross-sectional dimension of the column, and (iii) 450 mm.
- (c) The first tie shall be within a distance equal to $0.5s_0$ from the face of the joint.
- (d) The tie spacing shall not exceed $2s_0$ in any part of the column.

8.3.10 Requirements for Intermediate Moment Frames

8.3.10.1 Scope

For structures assigned to SDC C, structural frames proportioned to resist forces induced by earthquake motions shall satisfy the requirements of Sec 8.3.10 in addition to those of Chapter 6.

8.3.10.2 Reinforcement requirements

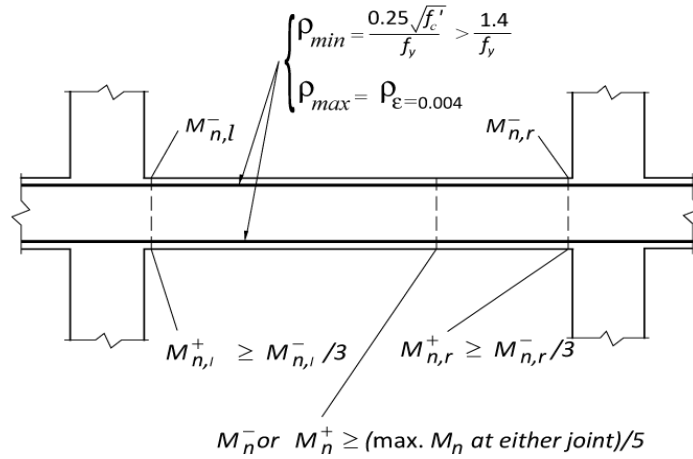
Reinforcement details in a frame member shall satisfy 8.3.10.4 below if the factored compressive axial load for the member does not exceed $0.1A_g f'_c$. If the factored compressive axial load is larger, frame reinforcement details shall satisfy Sec 8.3.10.5 below unless the member has spiral reinforcement according to Eq. 6.6.12. If a two-way slab system without beams is treated as part of a frame resisting earthquake effect, reinforcement details in any span resisting moments caused by lateral force shall satisfy Sec 8.3.10.6 below.

8.3.10.3 Shear requirements

Design shear strength of beams and columns resisting earthquake effect, E , shall not be less than the smaller of (i) sum of the shear associated with development of nominal moment strengths of the member at each restrained end of clear span and the shear calculated for factored gravity loads, or (ii) maximum shear obtained from design load combinations that include E , with the E assumed to be twice that prescribed by this Code.

8.3.10.4 Beams

- (a) The positive moment strength at the face of the joint shall not be less than one-third the negative moment strength provided at that face (Figure 6.8.17). Neither the negative nor positive moment strength at any section along the length of the member shall be less than one-fifth of the maximum moment strength provided at the face of either joint.
- (b) At both ends of the member, stirrups shall be provided over lengths equal to twice the member depth measured from the face of the supporting member toward midspan (Figure 6.8.18). The first stirrup shall be located not more than 50 mm from the face of the supporting member. Maximum stirrup spacing shall not exceed (a) $\frac{d}{4}$ (b) 8 times the diameter of the smallest longitudinal bar enclosed, (c) 24 times the diameter of the stirrup bar, and (d) 300 mm.
- (c) Stirrups shall be placed at not more than $\frac{d}{2}$ throughout the length of the member.



Note: Transverse reinforcement not shown for clarity

Figure 6.8.17 Flexural requirements for beams (IMF)

8.3.10.5 Columns

- (a) Maximum tie spacing shall not exceed s_0 over a length l_0 measured from the joint face. The spacing s_0 shall not exceed (i) 8 times the diameter of the smallest longitudinal bar enclosed, (ii) 24 times the diameter of the tie bar, (iii) one-half of the smallest cross-sectional dimension of the frame member, and (iv) 300 mm. The length l_0 shall not be less than (i) one-sixth of the clear span of the member, (ii) maximum cross-sectional dimension of the member, and (iii) 450 mm.
- (b) The first tie shall be located not more than $\frac{s_0}{2}$ from the joint face.
- (c) Joint reinforcement shall conform to Sec 6.4.9.
- (d) Tie spacing shall not exceed $2s_0$ throughout the length of the member.

These requirements are shown in Figure 6.8.19.

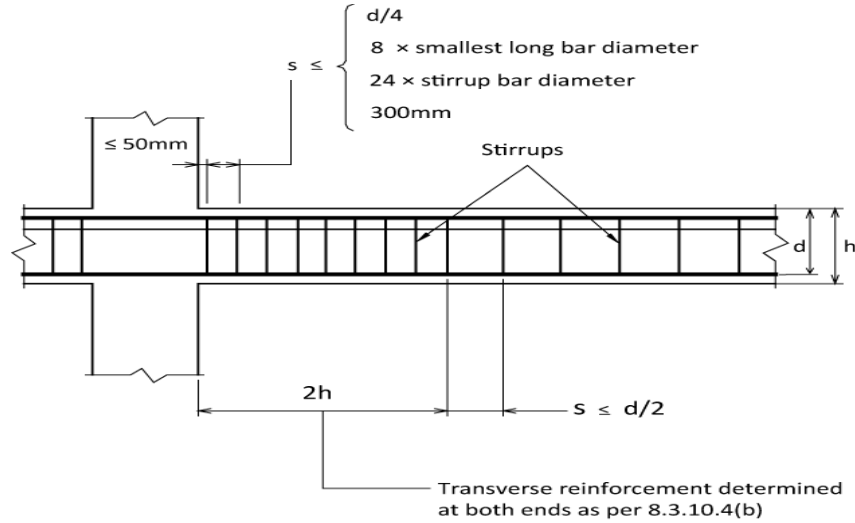


Figure 6.8.18 Transverse reinforcement requirements for beams (IMF)

8.3.10.6 Two-way slabs without beams

- (a) The factored slab moment at the supports relating to earthquake effect shall be determined for load combinations specified in Chapter 2, Loads. All reinforcement provided to resist the portion of slab moment balanced by support moment shall be placed within the column strip defined in Sec 6.5.2.1 (Figure 6.8.20).
- (b) The fractional part of the column strip moment shall be resisted by reinforcement placed within the effective width (Figure 6.8.20) specified in Sec 6.5.5.3.2.
- (c) Not less than one-half of the total reinforcement in the column strip at the support shall be placed within the effective slab width (Figure 6.8.15) specified in Sec 6.5.5.3.2.
- (d) Not less than one-quarter of the top steel at the support in the column strip shall be continuous throughout the span (Figure 6.8.21).
- (e) Continuous bottom reinforcement in the column strip shall be not less than one-third of the top reinforcement at the support in the column strip.

- (f) Not less than one-half of all bottom reinforcement at midspan shall be continuous and shall develop its yield strength at the face of support (Figure 6.8.22).
- (g) At discontinuous edges of the slab all top and bottom reinforcement at the support shall be developed at the face of the support (Figures 6.8.21 and 6.8.22).
- (h) For edge and corner connections flexural reinforcement perpendicular to the edge is not considered fully effective unless it is placed within the effective slab width as shown in Figure 6.8.23.

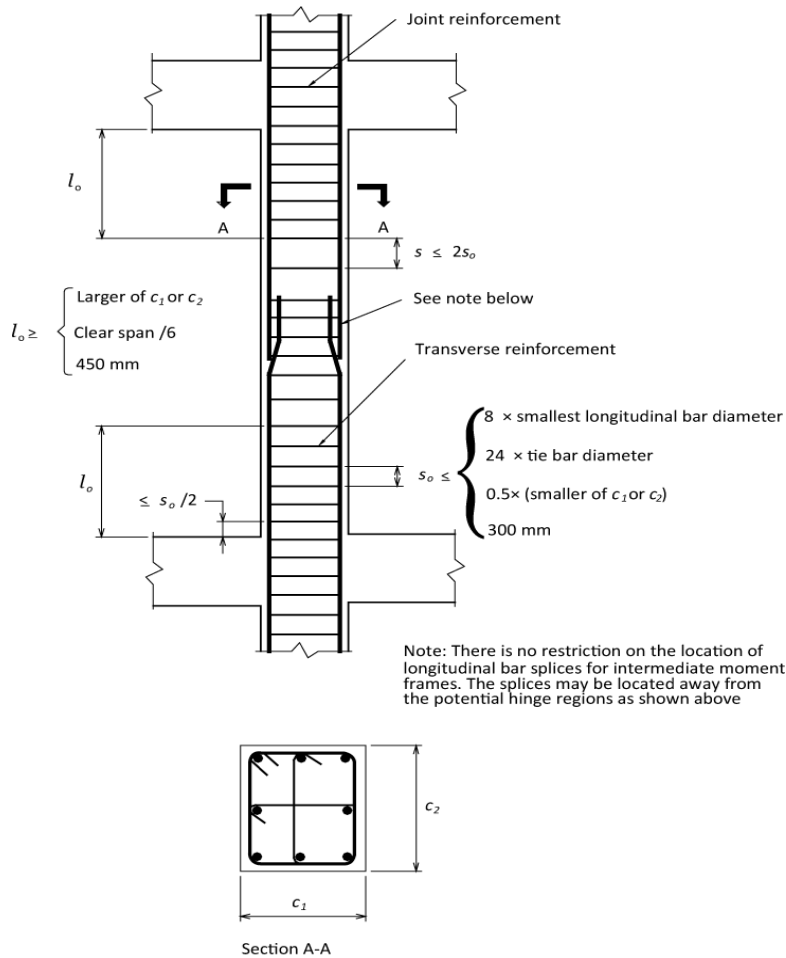


Figure 6.8.19 Transverse reinforcement requirements for columns (IMF)

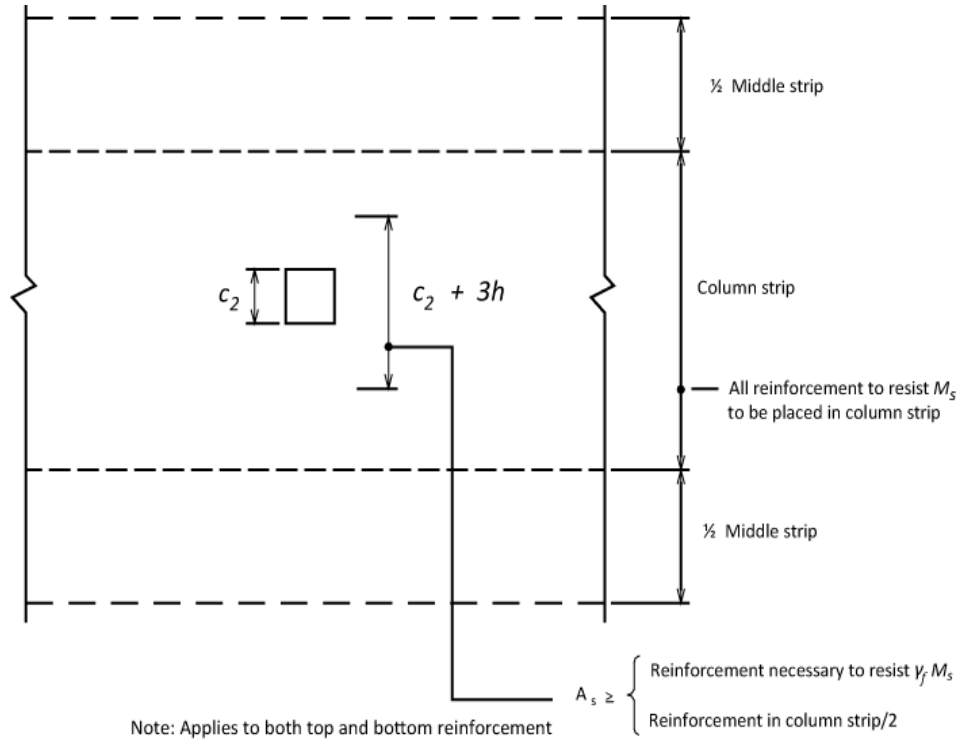


Figure 6.8.20 Reinforcement details at support of two-way slabs without beams

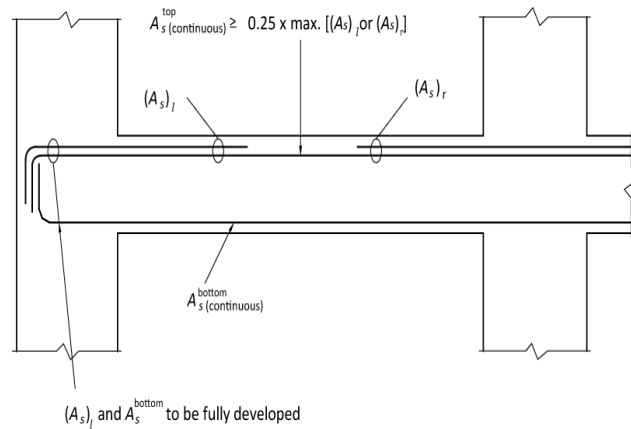


Figure 6.8.21 Reinforcement Details in Two-way Slabs without beams: Column Strip

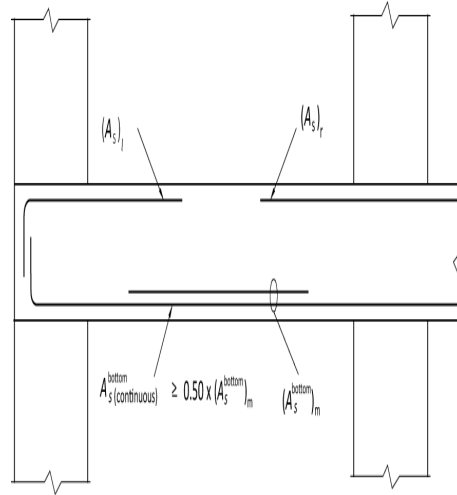


Figure 6.8.22 Reinforcement details in two-way slabs without beams: middle strip

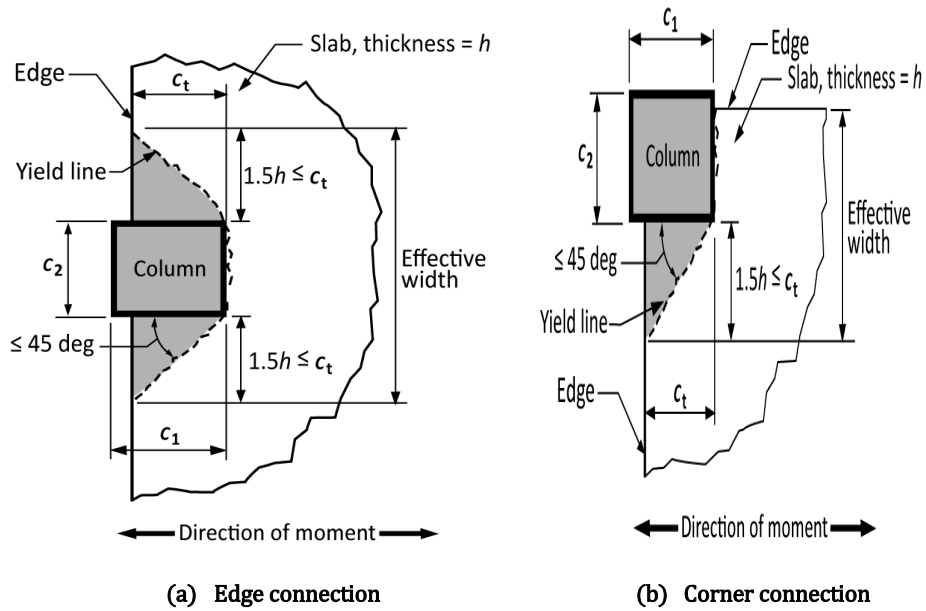


Figure 6.8.23 Effective width for reinforcement placement in edge and corner connections.

8.3.11 Requirements for Foundation

8.3.11.1 Scope

Foundations resisting earthquake induced forces or transferring earthquake-induced forces between structure and ground in structures assigned to SDC D shall comply with Sec 8.3.11 and other applicable Code provisions.

The provisions in this section for piles, drilled piers, caissons, and slabs-on-ground shall supplement other applicable Code design and construction criteria.

8.3.11.2 Footings, foundation mats, and pile caps

- (a) Longitudinal reinforcement of columns and structural walls resisting forces induced by earthquake effects shall extend into the footing, mat, or pile cap, and shall be fully developed for tension at the interface.
- (b) Columns designed assuming fixed-end conditions at the foundation shall comply with Sec 8.3.11.2(a) and, if hooks are required, longitudinal reinforcement resisting flexure shall have 90° hooks near the bottom of the foundation with the free end of the bars oriented toward the centre of the column.
- (c) Columns or boundary elements of special structural walls that have an edge within one-half the footing depth from an edge of the footing shall have transverse reinforcement in accordance with Sec 8.3.5.4 provided below the top of the footing. This reinforcement shall extend into the footing, mat, or pile cap and be developed for f_y in tension.
- (d) Where earthquake effects create uplift forces in boundary elements of special structural walls or columns, flexural reinforcement shall be provided in the top of the footing, mat, or pile cap to resist actions resulting from the design load combinations, and shall not be less than required by Sec 6.3.5.

8.3.11.3 Grade beams and slabs-on-ground

- (a) Grade beams designed to act as horizontal ties between pile caps or footings shall have continuous longitudinal reinforcement that shall be developed within or beyond the supported column or anchored within the pile cap or footing at all discontinuities.
- (b) Grade beams designed to act as horizontal ties between pile caps or footings shall be proportioned such that the smallest cross-sectional dimension shall be equal to or greater than the clear spacing between connected columns divided by 20, but need not be greater than 450 mm. Closed ties shall be provided at a spacing not to exceed the lesser of one-half the smallest orthogonal cross-sectional dimension and 300 mm.

- (c) Grade beams and beams that are part of a mat foundation subjected to flexure from columns that are part of the seismic-force-resisting system shall conform to Sec 8.3.4.
- (d) Slabs-on-ground that resist seismic forces from walls or columns that are part of the seismic-force-resisting system shall be designed as structural diaphragms in accordance with Sec 8.3.6. The design drawings shall clearly state that the slab on ground is a structural diaphragm and part of the seismic-force-resisting system.

8.3.11.4 Piles, piers, and caissons

- (a) Provisions of Sec 8.3.11.4 shall apply to concrete piles, piers, and caissons supporting structures designed for earthquake resistance.
- (b) Piles, piers, or caissons resisting tension loads shall have continuous longitudinal reinforcement over the length resisting design tension forces. The longitudinal reinforcement shall be detailed to transfer tension forces within the pile cap to supported structural members as shown in Figure 6.8.24.
- (c) Where tension forces induced by earthquake effects are transferred between pile cap or mat foundation and precast pile by reinforcing bars grouted or post-installed in the top of the pile, the grouting system shall have been demonstrated by test to develop at least $1.25f_y$ of the bar.
- (d) Piles, piers, or caissons shall have transverse reinforcement, Figure 6.8.24, in accordance with Sec 8.3.5.4 at locations—
 - (i) Top of the member for at least 5 times the member cross-sectional dimension, but not less than 1.8 m below the bottom of the pile cap;
 - (ii) Portion of piles in soil that is not capable of providing lateral support, or in air and water, along the entire unsupported length plus the length required in (i).
- (e) For precast concrete driven piles, the length of transverse reinforcement provided shall be sufficient to account for potential variations in the elevation in pile tips.
- (f) Concrete piles, piers, or caissons in foundations supporting one- and two-story stud bearing wall construction are exempt from the transverse reinforcement requirements of Sec 8.3.11.4(d) and (e).

- (g) Pile caps incorporating batter piles shall be designed to resist the full compressive strength of the batter piles acting as short columns. The slenderness effects of batter piles shall be considered for the portion of the piles in soil that is not capable of providing lateral support, or in air or water.

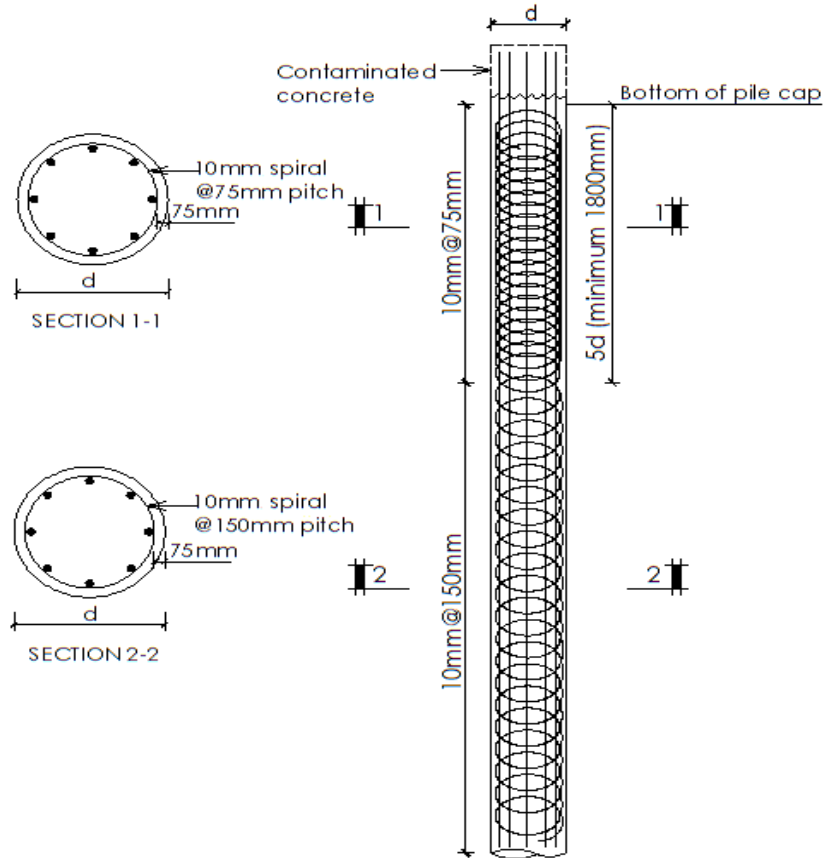


Figure 6.8.24 Spiral details of cast-in-situ pile in seismic zone 4 and SDC D

8.3.12 Requirement Members not Designated as Part of the Seismic-Force-Resisting System

8.3.12.1 Scope

- (a) Requirements of Sec 8.3.12 apply to frame members not designated as part of the seismic-force-resisting system in structures assigned to SDC D.

Frame members assumed not to contribute to lateral resistance, except two-way slabs without beams, shall be detailed according to Sec 8.3.12.2 or Sec 8.3.12.3 depending on the magnitude of moments induced in those members when subjected to the design displacement δ_u . If effects of δ_u are not explicitly checked, it shall be permitted to apply the requirements of Sec 8.3.12.3. For two-way slabs without beams, slab-column connections shall meet the requirements of Sec 8.3.12.5.

8.3.12.2 Induced moment and shear do not exceed design capacities

Where the induced moments and shears under design displacements, δ_u , combined with the factored gravity moments and shears do not exceed the design moment and shear strength of the frame member, the conditions of Sections 8.3.12.2(a), 8.3.12.2(b), and 8.3.12.2(c) shall be satisfied. The gravity load combinations of $(1.2D + 1.0L + 0.2S)$ or $0.9D$, whichever is critical, shall be used. The load factor on the live load, L , shall be permitted to be reduced to 0.5 except for garages, areas occupied as places of public assembly, and all areas where L is greater than 4.8 kN/m^2 .

- Members with factored gravity axial forces not exceeding $\frac{A_g f'_c}{10}$ shall satisfy Sec 8.3.4.2(a). Stirrups shall be spaced not more than $\frac{d}{2}$ throughout the length of the member.
- Members with factored gravity axial forces exceeding $\frac{A_g f'_c}{10}$ shall satisfy Sections 8.3.5.3(a) and 8.3.5.4. The maximum longitudinal spacing of ties shall be s_o for the full member length. Spacing s_o shall not exceed the smaller of six diameters of the smallest longitudinal bar enclosed and 150 mm.
- Members with factored gravity axial forces exceeding $0.35P_o$ shall satisfy Sec 8.3.12.2(b). The amount of transverse reinforcement provided shall be one-half of that required by Sec 8.3.5.4(a) but shall not be spaced greater than s_o for the full member length.

8.3.12.3 Induced moment or shear exceeds design capacities

If the induced moment or shear under design displacements, δ_u exceeds ϕM_n or ϕV_n of the frame member, or if induced moments are not calculated, the conditions of Sec 8.3.12.3(a), (b) and (c) shall be satisfied.

- Materials shall satisfy 8.3.3.3 and 8.3.3.4. Welded splices shall satisfy 8.3.3.5.
- Members with factored gravity axial forces not exceeding $\frac{A_g f'_c}{10}$ shall satisfy Sections 8.3.4.2 and 8.3.8. Stirrups shall be spaced at not more than $\frac{d}{2}$ throughout the length of the member.
- Members with factored gravity axial forces exceeding $\frac{A_g f'_c}{10}$ shall satisfy Sections 8.3.5.3, 8.3.5.4, 8.3.7.1 and 8.3.8.

8.3.12.4 Two-way slabs without beams

For slab-column connections of two-way slabs without beams, slab shear reinforcement satisfying the requirements of Sections 6.4.10.3 and 6.4.10.5 and providing V_s not less than $0.29\sqrt{f'_c} b_o d$ shall extend at least four times the slab thickness from the face of the support, unless either (i) or (ii) is satisfied :

- (i) The requirements of Sec 6.4.10.7 using the design shear V_{ug} and the induced moment transferred between the slab and column under the design displacement;
- (ii) The design story drift ratio does not exceed the larger of 0.005 and $\left[0.035 - 0.05 \left(\frac{V_{ug}}{\phi V_c}\right)\right]$.

Design story drift ratio shall be taken as the larger of the design story drift ratios of the adjacent stories above and below the slab-column connection. V_c is defined in Sec 6.4.10.2. V_{ug} is the factored shear force on the slab critical section for two-way action, calculated for the load combination $1.2D + 1.0L + 0.2S$.

The load factor on the live load, L , shall be permitted to be reduced to 0.5 except for garages, areas occupied as places of public assembly, and all areas where L is greater than 4.8 kN/m^2 .

PART VI
Chapter 9
Prestressed Concrete Structures

9.1 General

The Prestressed Concrete Structures Chapter of the Code is divided into the following three Divisions:

Division A : Design

Division B : Material and Construction

Division C : Maintenance

Division A : Scope, Definitions, Notation, Design And Analysis (Sections 9.2 To 9.18)

9.2 Scope

9.2.1 Provisions of this Chapter shall apply to members prestressed with wires, strands, or bars conforming to the specifications of prestressing tendons given in Sec 9.5.1.3.

9.2.2 All provisions of this Code not specifically excluded, and not in conflict with provisions of this Chapter 9, shall apply to prestressed concrete.

9.3 Definitions, Symbols and Notation

9.3.1 Definitions

ACTION	Mechanical force or environmental effect to which the structure (or structural component) is subjected.
ANALYSIS	Acceptable methods of evaluating the performance indices or verifying the compliance of specific criteria.
ANCHORAGE	In post-tensioning, a mechanical device used to anchor the tendon to the concrete; in pretensioning, a device used to anchor the tendon until the concrete has reached a pre-determined strength, and the prestressing force has been transferred to the concrete; for reinforcing bars, a length of reinforcement, or a mechanical anchor or hook, or combination thereof at the end of a bar needed to transfer the force carried by the bar into the concrete.

ANCHORAGE BLISTER	A build-up area on the web, flange, or flange-web junction for the incorporation of tendon anchorage fittings.
ANCHORAGE ZONE	The portion of the structure in which the prestressing force is transferred from the anchorage device on to the local zone of the concrete, and then distributed more widely in the general zone of the structure.
AT JACKING	At the time of tensioning the prestressing tendons.
AT LOADING	The maturity of the concrete when loads are applied. Such loads include prestressing forces and permanent loads but generally not live loads.
AT TRANSFER	Immediately after the transfer of prestressing force to the concrete.
AUTOGENEOUS SHRINKAGE	Volume decrease due to loss of water in the hydration process causing negative pore pressure in concrete.
BIOLOGICAL DEGRADATION	The physical or chemical degradation of concrete due to the effect of organic matters such as bacteria, lichens, fungi, moss, etc.
BONDED MEMBER	A prestressed concrete member in which tendons are bonded to the concrete either directly or through grouting.
BONDED POST- TENSIONING	Post-tensioned construction in which the annular space around the tendons is grouted after stressing, thereby bonding the tendon to the concrete section.
BONDED TENDON	Prestressing tendon that is bonded to concrete either directly or through grouting.
BURSTING FORCE	Tensile forces in the concrete in the vicinity of the transfer or anchorage of prestressing forces.
CAST-IN-PLACE CONCRETE	Concrete placed in its final position in the structure while still in a plastic state.
CHARACTERISTIC STRENGTH	Unless otherwise stated in this Code, the characteristic strength of material refers to the value of the strength below which none of the test results should fall below by more than 15% or 3.5 MPa for ≤ 35 MPa concrete, and 10% or 3.5 MPa for ≥ 35 MPa concrete, whichever is larger.

CHEMICAL ADMIXTUREs	Admixtures which are usually used in small quantities typically in the form of liquid and can be added to the concrete both at the time of mixing and before placing to improve various concrete properties such as workability, air content and durability, etc.
CLOSELY SPACED ANCHORAGES	Anchorage devices are defined as closely spaced if their centre to centre spacing does not exceed 1.5 times the width of the anchorage devices in the direction considered.
CLOSURE	A placement of cast-in-place concrete used to connect two or more previously cast portions of a structure.
COMPOSITE CONSTRUCTION	Concrete components or concrete and steel components interconnected to respond to force effects as a unit.
COMPRESSION- CONTROLLED SECTION	A cross-section in which the net tensile strain in the extreme tension steel at nominal resistance is less than or equal to the compression-controlled strain limit.
COMPRESSION- CONTROLLED STRAIN LIMIT	The net tensile strain in the extreme tension steel at balanced strain conditions.
CONCRETE COVER	The specified minimum distance between the surface of the reinforcing bars, strands, post-tensioning ducts, anchorages, or other embedded items, and the surface of the concrete.
CONFINEMENT	A condition where the disintegration of the concrete under compression is prevented by the development of lateral and/or circumferential forces such as may be provided by appropriate reinforcing steel or composite tubes, or similar devices.
CONFINEMENT ANCHORAGE	Anchorage for a post-tensioning tendon that functions on the basis of containment of the concrete in the anchorage zone by special reinforcement.
CREEP	Time dependent deformation of concrete under permanent load.
CREEP COEFFICIENT	The ratio of creep strain to elastic strain in concrete.
CREEP IN CONCRETE	Increase in strain with time in concrete subjected to sustained stress.

CURVATURE FRICTION	Friction resulting from bends or curves in the specified prestressing tend stage at which the compressive stresses on profile.
DAMAGE CONTROL	A means to ensure that the limit state requirement is met for restorability or reparability of a structure.
DECOMPRESSION	The stage at which the compressive stresses, induced prestress, are overcome by the tensile stresses.
DEFORMABILITY	A term expressing the ability of concrete to deform.
DEGREE OF DETERIORATION	The extent to which the performance of a structure is degraded or the extent to which the deterioration has progressed from the time of construction, as a result of its exposure to the environment.
DESIGN LIFE	Assumed period for which the structure is to be used satisfactorily for its intended purpose or function with anticipated maintenance but without substantial repair being necessary.
DETERIORATION INDEX	An index selected for estimating and evaluating the extent of the deterioration process.
DETERIORATION PREDICTION	Prediction of the future rate of deterioration of a structure based on results of inspection and relevant records made during the design and construction stages.
DEVIATION SADDLE	A concrete block build-out in web, flange, or web-flange junction used to control the geometry of or to provide a means for changing direction of, external tendons.
DRYING SHRINKAGE	Volume decrease due to loss of moisture from concrete in the hardened state which is usually serious in hot and dry environment.
DURABILITY DESIGN	Design to ensure that the structure can maintain its required functions during service life under environmental actions.
DURABILITY GRADE	The extent of durability to which the structure shall be maintained in order to satisfy the required performance during its design life. This affects the degree and frequency of the remedial actions to be carried out during that life.

DYNAMIC APPROACH	An approach based on dynamic analysis to assess the overall forces on a structure liable to have a resonant response to wind action.
DYNAMIC RESPONSE FACTOR	Factor to account for the effects of correlation and resonant response.
EARLY AGE STATE	The state of concrete from final setting until the achievement of the required characteristic strength.
EFFECTIVE PRESTRESS	Stress remaining in prestressing tendons after all losses have occurred, excluding effects of dead load and superimposed load.
ENVIRONMENTAL ACTIONS	An assembly of physical, chemical or biological influences which may cause deterioration to the materials making up the structure, which in turn may adversely affect its serviceability, restorability and safety.
FATIGUE LOADS	Repetitive loads causing fatigue in the material which reduces its strength, stiffness and deformability.
FINAL PRESTRESS	Stress which exists after substantially all losses have occurred.
FINAL TENSION	The tension in the steel corresponding to the state of the final prestress.
FORMWORK	Total system of support for freshly placed concrete including the mould or sheathing, all supporting members, hardware and necessary bracings.
FUNCTION	The task which a structure is required to perform.
GENERAL ZONE	Region adjacent to a post-tensioned anchorage within which the prestressing force spreads out to an essentially linear stress distribution over the cross section of the component.
GROUT	A mixture of cementitious material and water with or without admixtures.
INITIAL PRESTRESS	The prestress in the concrete at transfer.
INITIAL TENSION	The maximum stress induced in the prestressing tendon at the time of stressing operation.

JACKING FORCE	Temporary force exerted by device that introduces tension into prestressing tendons.
LIMIT STATE	A critical state specified using a performance index, beyond which the structure no longer satisfies the design performance requirements.
LIMITS OF DISPLACEMENT	Allowable deformation of structure in terms of such parameters as inter-storey drift and relative horizontal displacement, to control excessive deflection, cracking and vibration.
LONG-TERM PERFORMANCE INDEX	Index defining the remaining capacity of a structure in performing its design functions during the design life.
LOCAL ZONE	The volume of concrete that surrounds and is immediately ahead of the anchorage device and that is subjected to high compressive stresses.
MAINTENANCE	A set of activities taken to ensure that the structure continues to perform its functions satisfactorily during the design life.
MECHANICAL FORCES	An assembly of concentrated or distributed forces acting on a structure, or deformations imposed on it.
MODEL	Mathematical description or experimental setup simulating the actions, material properties and behavior of a structure.
MONITORING	Continuous recording of data pertaining to deterioration and/or performance of structure using appropriate equipment.
NOMINAL STRENGTH OF MATERIAL	The characteristic values of the strength of materials used for calculation, in absence of the available statistical data.
NORMAL CONCRETE	Concrete which is commonly used in construction; it does not include special constituent materials other than Portland cement, water, fine aggregate, coarse aggregate and common mineral and chemical admixtures; it does not require any special practice for its manufacturing and handling.

OVERALL PERFORMANCE INDEX	Index indicating the overall performance of the structure.
PARTIAL PERFORMANCE INDEX	Index indicating a partial performance of the structure.
PARTIAL SAFETY FACTOR FOR MATERIAL	For analysis purposes, the design strength of a material is determined as the characteristic strength divided by a partial safety factor.
PERFORMANCE	Ability (or efficiency) of a structure to perform its design functions.
PERFORMANCE INDEX	Index indicating structural performance quantitatively.
PERMANENT ACTIONS	Self-weights of structures inclusive of permanent attachments, fixtures and fittings.
PLASTIC SHRINKAGE	Shrinkage arising from loss of water from the exposed surface of concrete during the plastic state, leading to cracking at the exposed surface.
PLASTIC STATE	The state of concrete from just after placing until the final setting of concrete.
POST-TENSIONING	Method of prestressing in which tendons are tensioned after concrete has hardened.
PRESTRESSED CONCRETE	Reinforced concrete in which internal stresses have been introduced to reduce potential tensile stresses in concrete resulting from loads.
PRETENSIONING	Method of prestressing in which tendons are tensioned before concrete is placed.
SHRINKAGE LOSS	The loss of stress in the prestressing steel resulting from the shrinkage of concrete.
RELIABILITY	Ability of a structure to fulfill specified requirements during its design life.
REMAINING SERVICE LIFE	Period from the point of inspection to the time when the structure is no longer useable, or does not satisfactorily perform the functions determined at the time of design.

REMEDIAL ACTION	Maintenance action carried out with the objective of arresting or slowing down the deterioration process, restoring or improving the performance of a structure, or reducing the danger of damage or injury to the users or any third party.
REPAIR	Remedial action taken with the objective of arresting or slowing down the deterioration of a structure, or reducing the possibility of damage to the users or third party.
RESTORABILITY	Ability of a structure to be repaired physically and economically when damaged under the effects of considered actions. Also known as REPAIRABILITY.
ROBUSTNESS	Ability of a structure to withstand damage by events like fire, explosion, impact, instability or consequences of human errors. Also known as STRUCTURAL INSENSITIVITY.
SAFETY	Ability of a structure to ensure that no harm would come to the users and to people in the vicinity of the structure under any action.
SERVICE LIFE	The length of time from the completion of a structure until the time when it is no longer usable because of its failure to adequately perform its design functions.
SERVICEABILITY	Ability of a structure to provide adequate services or functionality in use under the effects of considered actions.
SETTLEMENT OF CONCRETE	Sinking of the concrete surface after placing due to bleeding and/or escaping of the entrapped and entrained air in the concrete.
SPECIAL CONCRETE	Concrete other than normal concrete including light weight concrete, roller compacted concrete, self-compacting concrete, fiber-reinforced concrete, anti-washout under water concrete, etc.
STIFF AND FLEXIBLE STRUCTURES	Stiff structures refer to those that are not sensitive to dynamic effects of wind, while flexible ones are those that are sensitive to such effects.
STRENGTHENING	Remedial action applied to a structure with the objective of restoring or improving its load bearing capacity to a level which is equal to, or higher than, the original design level.

STRESS AT TRANSFER	The stress in both the prestressing tendon and the concrete at the stage when the prestressing tendon is released from the prestressing mechanism.
TEMPERATURE CRACKING	Cracking caused by thermal stress which arises from differential temperatures in the concrete mass.
TENDON	Steel element such as wire, cable, bar, rod, or strand, or a bundle of such elements, used to impart prestress to concrete.
THRESHOLD LEVEL OF PERFORMANCE	Minimum acceptable level of performance of a structure.
TRANSFER	Act of transferring stress in prestressing tendons from jacks or pretensioning bed to concrete member.
TRANSFER LENGTH	The distance required at the end of a pretensioned tendon for developing the maximum tendon stress by bond.
ULTIMATE LIMIT STATE	Limit state for safety.
VARIABLE ACTION	Action due to a moving object on the structure as well as any load whose intensity is variable, including traffic load, wave load, water pressure, and load induced by temperature variation.
WOBBLE FRICTION	Friction caused by unintended deviation of prestressing sheath or duct from its specified profile.
WORKABILITY	The term expressing the ease with which concrete can be placed, compacted and filled.

9.3.2 Notation and Symbols

A	= Area of the part of cross-section between flexural tension face and centre of gravity of gross section, mm ²
A_{ch}	= Cross-sectional area of a structural member measured to the outside edges of transverse reinforcement, mm ²
A_g	= Gross area of concrete section, mm ² . For a hollow section, A_g is the area of the concrete only and does not include the area of the void(s)
A_{ps}	= Area of prestressed reinforcement in tension zone, mm ²

A_s	= Area of nonprestressed tension reinforcement, mm ²
A'_s	= Area of compression reinforcement, mm ²
C_c	= Clear cover of reinforcement, mm
D	= Dead loads, or related internal moments and forces
I	= Moment of inertia of cross-section resisting externally applied factored loads, mm ⁴
I_{cr}	= Moment of inertia of cracked section transformed to concrete, mm ⁴ , Sec 6.
I_g	= Moment of inertia of gross concrete section about centroidal axis, neglecting reinforcement, mm ⁴
I_e	= Effective moment of inertia for computation of deflection, mm ⁴
K	= Wobble friction coefficient per meter of prestressing tendon
L	= Live loads, or related internal moments and forces
M_a	= Maximum moment in member due to service loads at stage deflection is computed, N-mm
M_{cr}	= Moment causing flexural cracking at section due to externally applied loads, N-mm
M_{max}	= Maximum factored moment at section due to externally applied loads, N-mm
M_u	= Factored moment at section, N-mm
N_c	= Tensile force in concrete due to unfactored dead load plus live load (D + L), N
P_j	= Prestressing tendon force at jacking end, N
PI_P	= Inherent or possessed performance index
PI_R	= Inherent or possessed performance index
P_x	= Prestressing tendon force at any point x
V_c	= Nominal shear strength provided by concrete, N
V_{ci}	= Nominal shear strength provided by concrete when diagonal cracking results from combined shear and moment, N

V_{cw}	= Nominal shear strength provided by concrete when diagonal cracking results from excessive principal tensile stress in web, N
V_d	= Shear force at section due to unfactored dead load, N
V_i	= Factored shear force at section due to externally applied loads occurring simultaneously with M_{max} , N
V_n	= Nominal shear strength, N
V_p	= Vertical component of effective prestress force at section, N
V_s	= Nominal shear strength provided by shear reinforcement, N
V_u	= Factored shear force at section, N
X	= Shorter overall dimension of rectangular part of cross-section
a	= Depth of equivalent rectangular stress block, mm
b	= Width of compression face of member, mm
d	= Distance from extreme compression fiber to centroid of nonprestressed tension reinforcement, mm
d'	= Distance from extreme compression fiber to centroid of compression reinforcement, mm
d_b	= Nominal diameter of bar, wire, or prestressing strand, mm
d_p	= Distance from extreme compression fiber to centroid of prestressed reinforcement, mm
e	= Base of Napierian logarithm
f'_c	= Specified compressive strength of concrete, N/mm ²
f'_{ci}	= Compressive strength of concrete at transfer of prestress, N/mm ²
f_d	= Stress due to unfactored dead load, at extreme fiber of section where tensile stress is caused by externally applied loads, N/mm ²
f_{pe}	= Compressive stress in concrete due to effective prestress forces only (after allowance for all prestress losses) at extreme fiber of section where tensile stress is caused by externally applied loads, N/mm ²
f_{pc}	= Average compressive stress in concrete due to effective prestress force only (after allowance for all prestress losses), N/mm ²

f_{ps}	= Stress in prestressed reinforcement at nominal strength, N/mm ²
f_{pu}	= Specified tensile strength of prestressing tendons, N/mm ²
f_{py}	= Specified yield strength of prestressing tendons, N/mm ²
f_r	= Modulus of rupture of concrete, N/mm ²
f_{se}	= Effective stress in prestressed reinforcement (after allowance for all prestress losses), N/mm ²
f_t	= Extreme fiber stress in tension in the pre-compressed tensile zone calculated at service loads using gross section properties, N/mm ² (MPa)
f_y	= Specified yield strength of nonprestressed reinforcement, N/mm ²
f_{yt}	= Specified yield strength f_y of transverse reinforcement, N/mm ²
h	= Overall thickness of member, mm
h_f	= Overall thickness of flange of flanged section, mm
l	= Length of span of two-way flat plates in direction parallel to that of the reinforcement being determined, mm
l_x	= Length of prestressing tendon element from jacking end to any point x , metre
s	= Spacing of shear or torsion reinforcement in direction parallel to longitudinal reinforcement, mm
y	= Longer overall dimension of rectangular part of cross-section
y_t	= Distance from centroidal axis of gross section, neglecting reinforcement, to extreme fibre in tension
α	= Total angular change of prestressing tendon profile in radians from tendon jacking end to a point x
β_1	= Factor relating depth of equivalent rectangular compressive stress block to neutral axis depth
γ_p	= A factor for type of prestressing steel
μ	= Curvature friction coefficient
λ	= Modification factor reflecting the reduced mechanical properties of lightweight concrete, all relative to normal weight concrete of the same compressive strength (i.e., $\lambda = 1.0$ for normal weight concrete and 0.75 for all lightweight concrete. Else, λ shall be determined based on volumetric proportions of lightweight and normal weight aggregates, but shall not exceed 0.85.)

ρ	=	Ratio of nonprestressed tension reinforcement = $A_s/(bd)$
ρ'	=	Ratio of compression reinforcement = $A'_s/(bd)$
ρ_p	=	Ratio of prestressed reinforcement = $A_{ps}/(bd_p)$
ϕ	=	Strength reduction factor
ω	=	$\rho f_y/f'_c$
ω'	=	$\rho' f_y/f'_c$
ω_p	=	$\rho_p f_{ps}/f'_c$
$\omega_p, \alpha_p \omega$	=	Reinforcement indices for flanged sections computed for ω , ω_p and ω' except that b shall be the web width, and reinforcement area shall be that required to develop compressive strength of web only.
ω_w		

For other symbols and units of quantities, reference may be made to Chapter 6.

9.4 Analysis and Design

9.4.1 General

9.4.1.1 Prestressed members shall be designed for adequate strength in accordance with the provisions of this Chapter.

9.4.1.2 Unless specifically excluded or superseded by the provisions of this Chapter, all other relevant provisions of this Code shall apply to prestressed concrete.

9.4.1.3 Design of prestressed members shall be based on strength and on the behavior at service conditions at all stages that will be critical during the life of the structure from the time prestress is first applied.

9.4.1.4 Stress concentrations due to prestressing shall be considered in design.

9.4.1.5 Provisions shall be made for effects on adjoining construction of elastic and plastic deformations, deflections, changes in length and rotations due to prestressing. Effects of creep, temperature and shrinkage shall also be considered.

9.4.1.6 The possibility of buckling in a member between points where there is intermittent contact between prestressing steel and an oversized duct and buckling in thin webs and flanges shall be considered.

9.4.1.7 In computing section properties before bonding of prestressing steel, effect of loss of area due to open ducts shall be considered.

9.4.1.8 Thermal gradient and differential shrinkage shall be considered in composite construction using prestressed concrete members.

9.4.1.9 In evaluating the slenderness effects during lifting of slender beams, consideration shall be given to beam geometry, location of lifting points, method of lifting and tolerances in construction. All beams which are lifted on vertical or inclined slings shall be checked for lateral stability and lateral moment on account of tilting of beam. Reference may be made to specialist literature in this regard.

9.4.2 Design Assumptions

9.4.2.1 Strength design of prestressed members for flexure and axial loads shall be based on assumptions given in Sections 9.4.2.2 to 9.4.2.7 and shall satisfy the applicable conditions of equilibrium and compatibility of strains.

9.4.2.2 Strains in steel and concrete shall be assumed to be directly proportional to the distance from the neutral axis except for Deep Beams.

9.4.2.3 If nonprestressed reinforcement conforming to Sec 5.3.2 is used then, stress in such reinforcements below f_y , shall be taken as E_s times steel strain. For strains greater than that corresponding to f_y , stress in reinforcement shall be considered independent of strain and equal to f_y .

9.4.2.4 Maximum usable strain at extreme concrete compression fiber shall be assumed equal to 0.003.

9.4.2.5 The relationship between concrete compressive stress distribution and concrete strain shall be assumed to be rectangular, trapezoidal, parabolic, or any other shape that results in prediction of strength in substantial agreement with results of comprehensive tests

9.4.2.6 Requirements of Sec 9.4.2.5 are satisfied by an equivalent rectangular concrete stress distribution defined by the following:

- (a) Concrete stress of $0.85f'_c$ shall be assumed uniformly distributed over an equivalent compression zone bounded by edges of the cross section and a straight line located parallel to the neutral axis at a distance $a=\beta_1c$ from the fiber of maximum compressive strain.
- (b) Distance from the fiber of maximum strain to the neutral axis, c is measured in a direction perpendicular to the neutral axis.
- (c) For f'_c between 17.5 and 28 MPa, β_1 shall be taken as 0.85. For f'_c above 28 MPa, β_1 shall be reduced linearly at a rate of 0.05 for each 7 MPa of strength in excess of 28 MPa, but β_1 shall not be taken less than 0.65.

9.4.2.7 For investigation of stresses at transfer of prestress, at service loads, and at cracking loads, elastic theory shall be used with the following assumptions:

- (i) Strains vary linearly with depth through the entire load range.
- (ii) At cracked sections, concrete resists no tension.

9.4.3 Classification of Prestressed Concrete Members

Prestressed concrete flexural members shall be classified as Class U (uncracked), Class T (transition) and Class C (cracked) based on f_t , the computed extreme fiber stress in tension in the pre-compressed tensile zone calculated at service load as follows:

- (a) Class U: $f_t \leq 0.62\sqrt{f'_c}$
- (b) Class T: $0.62\sqrt{f'_c} \leq f_t \leq 1.0\sqrt{f'_c}$
- (c) Class C: $f_t > 1.0\sqrt{f'_c}$

Prestressed two-way slab systems shall be designed as class U with $f_t \leq 0.50\sqrt{f'_c}$

9.4.4 Shapes of Beams and Girders

For prestressed concrete non-composite beams/girders, the frequently used shapes are:

- (a) Symmetrical I-section,
- (b) Unsymmetrical I-section,
- (c) T-section,
- (d) Inverted T-section,
- (e) Box section and
- (f) Solid/hollow rectangular section.

Commentary:

The suitability of selecting a particular shape will depend on the specific design requirement and economy of construction. In general, T or equal or unequal I-section are common choices to achieve economy in steel and concrete. Due consideration to the simplicity of formwork is also required.

9.4.5 Material Properties for Design

9.4.5.1 Concrete Preparation and Design: Concrete shall be prepared, conveyed, placed/cast, cured, tested and maintained following appropriate sections of Chapter 5 of the Code. Relevant applicable standards are mentioned in Chapter 5 and also listed in Table 6.9.9. Unless specifically applicable to prestressed concrete, general design requirements of normal concrete are those of Chapter 6 of the Code.

9.4.5.2 Class: The Class of concrete is defined by the specified strength of concrete cylinder f'_c at 28 days. For example, Class 20 indicates concrete cylinder crushing strength of $f'_c = 20 \text{ N/mm}^2$. Commonly, the classes of concrete shall be in steps of 5 N/mm² as given by: Class 20, 25, 30 35... .. 65 and 70 etc. although concrete in between these classes may also be permitted (like class 21, 24, 28, 31, 38, 42, and 49 etc.).

9.4.5.3 Modulus of Elasticity, E_c : Modulus of elasticity, E_c for concrete shall be permitted to be taken as $w_c^{1.5} 0.043 \sqrt{f'_c}$ (in N/mm²) for values of w_c between 1440 and 2560 kg/m³. For normal weight concrete, E_c may be permitted to be taken as $4700 \sqrt{f'_c}$.

9.4.5.4 Modulus of Rupture, f_r : Modulus of rupture, f_r for concrete shall be permitted to be taken as $0.62 \lambda \sqrt{f'_c}$ where $\lambda = 1$ for normal weight concrete and 0.75 for all lightweight concrete.

9.4.5.5 Reinforcing steel: Appropriate applicable standards for reinforcing steel are given in Chapter 5 and also listed in Table 6.9.10. Unless specifically applicable to prestressed concrete, general design requirements of reinforcing steel are those that has been laid down in Chapter 6 of the Code.

9.4.5.6 Modulus of elasticity, E_s : Where it is not possible to ascertain the modulus of elasticity of reinforcing steel by test and from the manufacturer of steel, the modulus of elasticity of reinforcing steel may be permitted to be taken as $E_s = 200,000 \text{ N/mm}^2$.

9.4.5.7 Prestressing Steel: Appropriate applicable standards for prestressing steel are listed in Table 6.9.11.

9.4.5.8 Modulus of elasticity, E_s : Where it is not possible to ascertain the modulus of elasticity of plain/ indented steel wire and prestressing steel (bar or strand) by test and from the manufacturer of steel, the values of E_s given in Table 6.9.1 may be used:

Table 6.9.1: Modulus of Elasticity of Prestressing Steel and Cold Drawn Wire

Type of steel	Modulus of elasticity, E_s (kN/mm ²)
Plain/indented cold-drawn wire	200
High tensile steel bars rolled or heat-treated	205
Strands	195

9.5 Serviceability Requirements – Flexural Members

9.5.1 Stress in Concrete At Transfer

Stresses in concrete immediately after prestress transfer (before time-dependent prestress losses occur) are as follows:

- (a) Extreme fiber stress in compression except as permitted in (b) shall not exceed $0.60f'_{ci}$
- (b) Extreme fiber stress in compression at ends of simply support members shall not exceed $0.70f'_{ci}$
- (c) Where computed concrete tensile strength, f_t exceeds $0.5\sqrt{f'_c}$ at ends of simply supported members, or $0.25\sqrt{f'_c}$ at other locations, additional bonded reinforcement shall be provided in the tensile zone to resist the total tensile force in concrete computed with the assumption of an uncracked section.

Allowable stresses in concrete

For Class U and Class T prestressed flexural members, stresses in concrete at service loads (based on uncracked section properties and after allowance for all prestress losses) shall not exceed the following:

- (a) Extreme fiber stress in compression due to prestress plus sustained load $0.45f'_c$
- (b) Extreme fiber stress in compression due to prestress plus total load $0.60f'_c$

9.5.2 Permissible stresses in Sections 9.5.1 and 9.5.2 shall be permitted to be exceeded if shown by test or analysis that performance will not be impaired.

9.5.3 Reinforcement Spacing

9.5.3.1 For Class C prestressed flexural members not subject to fatigue or to aggressive exposure, the spacing s of bonded reinforcement nearest the extreme tension face shall not exceed that for normal Reinforced Concrete, as given below:

$$s = 380(280/f_s) - 2.5C_c \quad (6.9.1)$$

But, not greater than $300(280/f_s)$, where C_c is the least distance from the surface of reinforcement or prestressing steel to the tension face. If there is only one bar or wire nearest to the extreme tension face, s used in the above equation is the width of the extreme tension face.

Calculated stress f_s in reinforcement closest to the tension face at service loads shall be computed based on the unfactored moment. It shall be permitted to take f_s as $\frac{2}{3}f_y$.

For structures subject to fatigue or exposed to corrosive environments, investigations, judgment and precautions are required.

9.5.3.2 The spacing requirements Sec 9.5.3.1 shall be met by nonprestressed reinforcement and bonded tendons.

- (a) The spacing of bonded tendons shall not exceed $2/3^{\text{rd}}$ of the maximum spacing permitted for nonprestressed reinforcement.

Where both reinforcement and bonded tendons are used to meet the spacing requirement, the spacing between a bar and a tendon shall not exceed $5/6^{\text{th}}$ of that permitted by 9.5.3.1. See also (c) below.

- (b) In applying Eq. 6.9.1 to prestressing tendons, Δf_{ps} shall be substituted for f_s , where Δf_{ps} shall be taken as the calculated stress in the prestressing steel at service loads based on a cracked section analysis minus the decompression stress f_{dc} . It shall be permitted to take f_{dc} equal to the effective stress in the prestressing steel f_{se} . See also (c) below.
- (c) In applying Eq. 6.9.1 to prestressing tendons, the magnitude of Δf_{ps} shall not exceed 250 N/mm^2 . When Δf_{ps} is less than or equal to 140 N/mm^2 , the spacing requirements of Sec 9.5.3.2(a) and (b) shall not apply.
- (d) Where depth h of a beam exceeds 900 mm, the area of longitudinal skin reinforcement consisting of untensioned reinforcing steel or bonded tendons shall be uniformly distributed along both side faces of the member as required by Sec 6.3.6.7. The spacing s shall be determined using Sections 9.5.3.1 and 9.5.3.2 (a), (b) and (c). It shall be permitted to include such reinforcement in strength computations if a strain compatibility analysis is made to determine stress in the individual bars or wires.

9.5.4 Permissible Stresses in Prestressing Steel

Tensile stress in prestressing tendons shall not exceed the following:

- (a) Due to prestressing steel jacking force $0.94f_{py}$ but not greater than the lesser of $0.80f_{pu}$ and the maximum value recommended by the manufacturer of prestressing steel or anchorage devices.
- (b) Immediately after prestress transfer $0.82f_{py}$ but not greater than $0.74f_{pu}$.
- (c) Post-tensioning tendons, at anchorage devices and couplers, immediately after force transfer $0.70f_{pu}$

9.6 Losses of Prestress

Effective stress in prestressing steel is usually subject to different losses at different stages. Superimposed loads can result in gain of prestress due to bending of the member which shall be taken into consideration if significant. To determine effective stress in the prestressing steel, f_{se} , allowance for the following sources of loss of prestress shall be considered:

9.6.1 Immediate Losses

- (a) Loss due to elastic shortening of concrete;
- (b) Loss due to prestressing steel seating at transfer (Anchorage slip);
- (c) Loss due to friction (for post-tensioned concrete only).

9.6.2 Long-term Losses

- (a) Loss due to relaxation of prestressing steel stress;
- (b) Loss due to creep of concrete;
- (c) Loss due to shrinkage of concrete.

Unless otherwise determined by actual tests, allowance for these losses shall be made in accordance with the provisions of Sections 9.6.3 to 9.6.8.

9.6.3 Loss due to Elastic Shortening of Concrete

- (a) The loss of prestress due to immediate elastic shortening of adjacent concrete upon transfer of initial prestress shall be calculated as specified in this section. For pretensioning, the loss of prestress in the tendons at transfer shall be calculated on a modular ratio basis using the stress in the adjacent concrete.
- (b) For members with post-tensioned tendons which are not stressed simultaneously, there is a progressive loss of prestress during transfer due to the gradual application of the prestressing forces. This loss of prestress shall be calculated on the basis of half the product of the stress in the concrete adjacent to the tendons averaged along their lengths and the modular ratio. Alternatively, the loss of prestress may be exactly computed based on the sequence of tensioning.

9.6.4 Loss due to Prestressing Steel Seating at Transfer (Anchorage Slip)

- (a) Any loss of prestress which may occur due to slip of wire or strand during anchoring or due to straining of the anchorage shall be allowed for in the design.
- (b) Necessary additional elongation may be provided for at the time of tensioning to compensate for this loss.

9.6.5 Loss due to Relaxation of Prestressing Steel Stress

- (a) The relaxation losses in prestressing steel shall be determined from experiments. When experimental values are not available, the relaxation losses, considering normal relaxation steel, may be assumed as given in Table 6.9.2.

Table 6.9.2: Relaxation Losses for Prestressing Steel at 1000 Hours at 27°C

Initial Stress	Relaxation Loss N/mm ²
$0.5f_{pu}$	0
$0.6f_{pu}$	35
$0.7f_{pu}$	70
$0.8f_{pu}$	90

For tendons at higher temperature or subject to large lateral loads, greater relaxation losses may be allowed, subject to the advice of the metallurgy specialist.

- (b) No reduction in the value of the relaxation losses should be made for a tendon with a load equal to or greater than the relevant jacking force that has been applied for a short duration prior to the anchoring of the tendon.

9.6.6 Loss due to Creep of Concrete

- (a) Creep occurs due to superimposed permanent dead load added to the member after it has been prestressed. Creep of concrete may be assumed to be proportional to the stress provided the stress in concrete does not exceed 40 percent of its compressive strength.
- (b) In the absence of test data, the ultimate creep strain may be estimated from the following values of creep coefficient, which is the ratio of the ultimate creep strain to the elastic strain at the age of loading. Table 6.9.3 shows the values at different days.

Table 6.9.3: Creep Coefficient of Concrete

Age at Loading	Creep coefficient
7 days	2.2
28 days	1.6
1 year	1.1

- (c) The ultimate creep strain estimated as above does not include the elastic strain. For the calculation of deformation at some stage before the total creep is reached, it may be assumed that 50 percent of the total creep takes place in the first month after loading and about 75 percent of the total creep takes place in the first six months after loading. For post-tensioning the creep coefficients shall be taken as 80% of those given here.
- (d) The loss of prestress due to creep of concrete shall be determined for all the permanently applied loads including the prestress. Loss due to stresses of short duration including live load and erection stresses may be ignored.
- (e) The loss of prestress due to creep of concrete shall be obtained as the product of the modulus of elasticity of the prestressing steel and the ultimate creep strain of the concrete fiber integrated along the centre-line of the prestressing steel over its entire length.
- (f) The total creep strain during any specific period shall be assumed to be the creep strain due to sustained stress equal to the average of the stresses at the beginning and end of the period.

9.6.7 Loss due to Shrinkage of Concrete

- (a) In the absence of test data, the approximate value of shrinkage strain in concrete for design purposes shall be assumed as follows:

For pretensioning : 0.0003

For post-tensioning : $0.0002 / [\log_{10}(t + 2)]$

Where, t = age of concrete at transfer in days.

Other standard procedures like AASHTO LRFD Specifications may be used.

- (b) For the calculation of deformation of concrete at some stage before the maximum shrinkage occurs it may be assumed that 50 percent of the shrinkage takes place during the first month and about 75 percent of the shrinkage takes place in the first six months after drying of concrete starts.
- (c) The loss of prestress due to shrinkage of concrete shall be obtained as the product of the modulus of elasticity of steel and the shrinkage strain of concrete.

9.6.8 Loss due to Friction (For Post-tensioned Tendons Only)

- (a) The design shall take into consideration all losses in prestress that may occur during tensioning due to friction between the post-tensioning tendons and the surrounding concrete or any fixture attached to the steel or concrete.
- (b) The value of prestressing force P_x at a distance l_x metre from the jacking end and acting in the direction of the tangent to the curve of the cable shall be calculated from the relation:

$$P_x = P_j e^{-(Kl_x + \mu\alpha)} \tag{6.9.2}$$

When $(Kl_x + \mu\alpha)$ is greater than 0.3, P_x may be computed from

$$P_x = \frac{P_j}{1 + Kl_x + \mu\alpha} \tag{6.9.3}$$

For use in Equations 6.9.2 and 6.9.3, the values of wobble friction coefficient K and curvature friction coefficient μ shall be experimentally determined or obtained from the tendon manufacturer, and verified during tendon stressing operations.

- (c) Values of K and μ used in the design shall be shown on design drawings
- (d) In absence of test results or manufacturer's recommendation, the following values of μ and K shown in Table 6.9.4 may be taken as a guide:

Table 6.9.4: Friction Coefficients (K and μ) for Post-Tensioned Tendons

Types of Tendons		Coefficient, K per meter	Curvature coefficient, μ per radian
Grouted Tendons in metal sheathing	Wire tendons	0.0033-0.0049	0.15-0.25
	High-strength bars	0.0003-0.0020	0.08-0.30
	7-wire strand	0.0016-0.0066	0.15-0.25
Unbonded tendons	Mastic coated	Wire tendons	0.0033-0.0066
		7-wire strand	0.0033-0.0066
	Pre-greased	Wire tendons	0.001-0.0066
		7-wire strand	0.001-0.0066

9.6.9 Values of wobble and curvature friction coefficients used in design shall be shown on design drawings.

9.6.10 The effect of reverse friction shall be taken into consideration in such cases where the initial tension applied to a prestressing tendon is partially released (e.g., anchorage slip) and action of friction in the reverse direction causes significant alteration in the distribution of stress along the length of the tendon.

9.6.11 Where loss of prestress in a member occurs due to connection of member to adjoining construction, such loss of prestress shall be allowed for in design.

9.7 Control of Deflection

9.7.1 For prestressed concrete flexural members, designed in accordance with the provisions of this Chapter, immediate deflection shall be computed by usual methods or formulas for elastic deflections, and the moment of inertia of gross concrete section, I_g , shall be permitted to be used for Class U flexural members.

9.7.2 For Class C and Class T flexural members, deflection calculations shall be based on cracked transformed section analysis. It shall be permitted to base calculations on an effective moment of inertia, I_e as given in Eq. 6.9.4a.

$$I_e = \left(\frac{M_{cr}}{M_a}\right)^3 I_g + \left[1 - \left(\frac{M_{cr}}{M_a}\right)^3\right] I_{cr} \quad (6.9.4a)$$

$$M_{cr} = \frac{f_r I_g}{y_t} \quad (6.9.4b)$$

$$f_r = 0.62 \lambda \sqrt{f'_c} \quad (6.9.4c)$$

Deflection computed in accordance with Sec 9.7.1 shall not exceed the limits stipulated in Table 6.6.2, Chapter 6.

9.7.3 Additional long-term deflection of prestressed concrete members shall be computed taking into account stresses in concrete and steel under sustained load and including effects of creep and shrinkage of concrete and relaxation of steel.

9.8 Flexural Strength

9.8.1 Design moment strength of flexural members shall be computed by the strength methods of the Code. For prestressing steel, f_{ps} shall be substituted for f_y in strength computations.

9.8.2 As an alternative to a more accurate determination of f_{ps} based on strain compatibility, the following approximate values of f_{ps} shall be permitted to be used if f_{se} is not less than $0.5f_{pu}$.

(a) For members with bonded tendons

$$f_{ps} = f_{pu} \left[1 - \frac{\gamma_p}{\beta_1} \left\{ \rho_p \frac{f_{pu}}{f'_c} + \frac{d}{d_p} (\omega - \omega') \right\} \right] \quad (6.9.5)$$

Where, $\omega = \frac{\rho f_y}{f'_c}$, $\omega' = \frac{\rho' f_y}{f'_c}$ and γ_p is 0.55 for f_{py}/f_{pu} not less than 0.80; 0.40 for f_{py}/f_{pu} not less than 0.85; and 0.28 for f_{py}/f_{pu} not less than 0.90.

If any compression reinforcement is taken into account when calculating f_{ps} by Eq. 6.9.5:

The term $\left[\rho_p \frac{f_{pu}}{f'_c} + \frac{d}{d_p} (\omega - \omega') \right]$ shall be taken not less than 0.17 and d' shall be no greater than $0.15d_p$.

(b) For members with unbonded tendons and with a span-to-depth ratio of 35 or less:

$$f_{ps} = f_{se} + 70 + \frac{f'_c}{100\rho_p} \quad (6.9.6)$$

But f_{ps} in Eq. 6.9.6 shall not be taken greater than the lesser of f_{py} and $(f_{se} + 420)$.

(c) For members with unbonded tendons and with a span-to-depth ratio greater than 35:

$$f_{ps} = f_{se} + 70 + \frac{f'_c}{300\rho_p} \quad (6.9.7)$$

But, f_{ps} in Eq. 6.9.7 shall not be taken greater than the lesser of f_{py} and $(f_{se} + 210)$

9.8.3 Non prestressed reinforcement conforming to Sec 5.3 Chapter 5 of this Part, if used with prestressing steel, shall be permitted to be considered to contribute to the tensile force and to be included in moment strength computations at a stress equal to f_y . Other non prestressed reinforcement shall be permitted to be included in strength computations only if a strain compatibility analysis is performed to determine stresses in such reinforcement.

9.9 Limits For Flexural Reinforcement

9.9.1 Prestressed concrete sections shall be classified as either tension-controlled, transition, or compression-controlled sections, in accordance with a. and b. below.

- (a) Sections are compression-controlled if the net tensile strain in the extreme tension fiber ε_t , is equal to or less than the compression-controlled strain limit when the concrete in compression reaches its assumed strain limit of 0.003. The compression-controlled strain limit is the net tensile strain in the reinforcement at balanced strain conditions. For Grade 420 reinforcement, and for all prestressed reinforcement, it shall be permitted to set the compression-controlled strain limit to 0.002.
- (b) Sections are tension-controlled if the net tensile strain in the extreme tension steel, ε_t , is equal to or greater than 0.005 when the concrete in compression reaches its assumed strain limit of 0.003. Sections with ε_t between the compression-controlled strain limit and 0.005 constitute a transition region between compression-controlled and tension-controlled sections. Appropriate strength reduction factor, ϕ , from Sec 9.9.2 shall apply.

9.9.2 The appropriate strength reduction factor, ϕ , shall apply as given in (a) to (f) below.

- (a) Tension-controlled sections 0.90
- (b) For compression-controlled sections
 - (i) Members with spiral reinforcement as defined in Sec 6.2.3.2.20.75
 - (ii) Other reinforced members 0.65
- (c) Shear and torsion 0.75
- (d) Post-tensioned anchorage zones 0.85
- (e) Strut and tie models 0.75
- (f) Flexural sections in pre-tensioned members where strand embedment length is less than the development length
 - (i) From the end of the member to the end of the transfer length 0.75
 - (ii) From the end of transfer length to the end of the development length, ϕ shall be taken as 0.75 to 0.90

Where bonding of the strand does not extend to the end of the member, strand embedment shall be assumed to begin at the end of the debonded length.

9.9.3 Total amount of prestressed and non-prestressed reinforcement in members with bonded prestressed reinforcement shall be adequate to develop a factored load at least 1.2 times the cracking load computed on the basis of the modulus of rupture f_c , as given in Sec 9.4.5.4. This provision shall be permitted to be waived for flexural members with shear and flexural strength at least twice the required strength (U) calculated for the factored loads and forces in such combinations as are stipulated in Chapter 2, Loads.

9.9.4 Minimum Bonded Reinforcement

9.9.4.1 A minimum area of bonded reinforcement shall be provided in all flexural members with unbonded tendons as required by Sections 9.9.4.2 and 9.9.4.3.

9.9.4.2 Except as provided in Sec 9.9.4.3, minimum area of bonded reinforcement shall be computed by

$$A_s = 0.004A_{ct} \quad (6.9.8)$$

Where, A_{ct} is area of that part of cross-section between the flexural tension face and center of gravity of gross-section.

- (a) Bonded reinforcement required by Eq. 6.9.8 shall be uniformly distributed over pre-compressed tensile zone as close as practicable to extreme tension fibre.
- (b) Bonded reinforcement shall be required regardless of service load stress conditions.

9.9.4.3 For two-way flat slab systems, minimum area and distribution of bonded reinforcement shall be as required in (a), (b) and (c) below.

- (a) Bonded reinforcement shall not be required in positive moment areas where f_t , the extreme fibre stress in tension in the precompressed tensile zone at service loads (after allowance for all prestress losses), does not exceed $0.17\sqrt{f'_c}$.
- (b) In positive moment areas where computed tensile stress in concrete at service load exceeds $0.17\sqrt{f'_c}$ minimum area of bonded reinforcement shall be computed by

$$A_s = \frac{N_c}{0.5 f_y} \quad (6.9.9)$$

Where, the value of f_y used in Eq. 6.9.9 shall not exceed 420 MPa. Bonded reinforcement shall be uniformly distributed over precompressed tensile zone as close as practicable to the extreme tension fibre.

- (c) In negative moment areas at column supports, the minimum area of bonded reinforcement A_s in the top of the slab in each direction shall be computed by

$$A_s = 0.00075A_{cf} \quad (6.9.10)$$

Where, A_{cf} is the larger gross cross-sectional area of the slab-beam strips in two orthogonal equivalent frames intersecting at a column in a two-way slab.

9.9.4.4 Bonded reinforcement required by Eq. 6.9.10 shall be distributed between lines that are $1.5h$ outside opposite faces of the column support. At least four bars or wires shall be provided in each direction. Spacing of bonded reinforcement shall not exceed 300 mm.

9.9.4.5 Minimum length of bonded reinforcement required by Sections 9.9.4.2 and 9.9.4.3 shall be as required in Sec 9.9.4.5 (a), (b) and (c).

- (a) In positive moment areas, minimum length of bonded reinforcement shall be one-third the clear span length, l_n and centered in positive moment area.
- (b) In negative moment areas, bonded reinforcement shall extend one-sixth the clear span, l_n on each side of support.
- (c) Where bonded reinforcement is provided for ϕM_n in accordance with Sec 9.8.3 or for tensile stress conditions as per Sec 9.9.4.3 (b), minimum length also shall conform to provisions of Chapter 6.

9.10 Statically Indeterminate Structures

9.10.1 Frames and continuous construction of prestressed concrete shall be designed for satisfactory performance at service load conditions and for adequate strength.

9.10.2 Performance at service load conditions shall be determined by elastic analysis, considering reactions, moments, shears, and axial forces induced by prestressing, creep, shrinkage, temperature change, axial deformation, restraint of attached structural elements, and foundation settlement.

9.10.3 Moments used to compute required strength shall be the sum of the moments due to reactions induced by prestressing (with a load factor of 1.0) and the moments due to factored loads. Adjustment of the sum of these moments shall be permitted as allowed in Sec 9.10.4.

9.10.4 Redistribution of moments in continuous prestressed flexural members shall be:

- (a) Where bonded reinforcement is provided at supports in accordance with Sec 9.9.4, it shall be permitted to decrease negative or positive moments calculated by elastic theory for any assumed loading, in accordance with Sec 9.10.4 (b) and (c) below.
- (b) Except where approximate values for moments are used, it shall be permitted to decrease factored moments calculated by elastic theory at sections of maximum negative or maximum positive moment in any span of continuous flexural members for any assumed loading arrangement by not more than $100\varepsilon_t$ percent, with a maximum of 20 percent.
- (c) Redistribution of moment shall be made only when ε_t is equal to or greater than 0.0075 at the section at which moment is reduced.

9.10.5 The reduced moment shall be used for calculating redistributed moments at all other sections within the spans. Static equilibrium shall be maintained after redistribution of moments for each loading arrangement.

9.11 Compression Members - Combined Flexure And Axial Load

9.11.1 Prestressed Concrete Members Subject to Combined Flexure and Axial Load

With or without non-prestressed reinforcement, Prestressed concrete members subject to combined flexure and axial load shall be proportioned by the strength design methods of this Code. Effects of prestress, creep, shrinkage, and temperature change shall be included.

9.11.2 Limits for Reinforcement of Prestressed Compression Members

9.11.2.1 Members with average compressive stress in concrete less than 1.6 N/mm^2 , due to effective prestress force only, shall have minimum reinforcement in accordance with Sections 6.3.9.1, 6.3.9.2 for columns and Sec 6.6.3 for walls and minimum transverse reinforcement for compression members of Chapter 6.

9.11.2.2 Except for walls, members with average compressive stress in concrete due to effective prestress force only, equal to or greater than 1.6 N/mm^2 shall have all tendons enclosed by spirals or lateral ties in accordance with (a) through (d).

- (a) Spirals shall conform to the spiral reinforcement requirement for compression members of this Code and Sec 9.11.3.

- (b) Lateral ties shall be at least No. 10 in size or welded wire reinforcement of equivalent area, and shall be spaced vertically not to exceed 48 tie bar or wire diameters, or the least dimension of the compression member.
- (c) Ties shall be located vertically not more than half a tie spacing above top of footing or slab in any story, and not more than half a tie spacing below the lowest horizontal reinforcement in members supported above.
- (d) Where beams or brackets frame into all sides of a column, ties shall be terminated not more than 75 mm below lowest reinforcement in such beams or brackets.

9.11.2.3 For walls with average compressive stress in concrete due to effective prestress force only equal to or greater than 1.6 N/mm², minimum reinforcement required by Sec 6.6.3 shall not apply where structural analysis shows adequate strength and stability.

9.11.3 Volumetric Spiral Reinforcement Ratio

Volumetric spiral reinforcement ratio, ρ_s shall be not less than the value given by

$$\rho_s = 0.45 \left(\frac{A_g}{A_{ch}} - 1 \right) \frac{f'_c}{f_{yt}} \quad (6.9.11)$$

Where, the value of f_{yt} in Eq. 6.9.11 shall not exceed 700 N/mm². For f_{yt} greater than 420 N/mm², lap splices according to Sec 9.9.3.1(a) shall not be used.

- (a) Spiral reinforcement shall be spliced, if needed, by any one of the following methods:

Lap splices not less than the larger of 300 mm and the length indicated in Sec 8.1.9.3 (a) to (e) of Chapter 8 and summarized below:

- (i) deformed uncoated bar or wire $48d_b$
 - (ii) plain uncoated bar or wire $72d_b$
 - (iii) epoxy-coated deformed bar or wire $72d_b$
 - (iv) plain uncoated bar or wire with a standard stirrup or tie hook in accordance with Sec 8.1.9.3 (d) of Chapter 8 at ends of lapped spiral reinforcement.
- (b) The term “standard hook” as used in this Code shall mean one of the following:
 - (i) 180-degree bend plus $4d_b$ extension, but not less than 65 mm at free end of bar.
 - (ii) 90-degree bend plus $12d_b$ extension at free end of bar.

(c) For stirrup and tie hooks

- (i) No. 16 bar and smaller, 90° bend plus $6d_b$ extension at free end of bar; or
- (ii) No. 19, No. 22 bar and No. 25 bar, 90° bend plus $12d_b$ extension at free end of bar; or
- (iii) No. 25 bar and smaller, 135° bend plus $6d_b$ extension at free end of bar.

9.12 Slab Systems

9.12.1 Factored moments and shears in prestressed slab systems reinforced for flexure in more than one direction shall be determined in accordance with provisions of Sec 6.5.7 Chapter 6 or by more detailed design procedures.

9.12.2 ϕM_n of prestressed slabs with loads and load combinations required by Chapter 2 and 6 at every section shall be greater than or equal to M_u considering Sections 9.10.3 and 9.10.4. ϕV_n (design strength) of prestressed slabs at columns following Chapter 6 shall be greater than or equal to V_u (the required strength, Chapter 2).

9.12.3 At service load conditions, all serviceability limitations, including limits on deflections, shall be met, with appropriate consideration of the factors listed in Sec 9.10.2.

9.12.4 For uniformly distributed loads, spacing of tendons or groups of tendons in at least one direction shall not exceed the smaller of eight times the slab thickness and 1.5 m. Spacing of tendons also shall provide a minimum average effective prestress of 0.9 N/mm² on the slab section tributary to the tendon or tendon group. For slabs with varying cross section along the slab span, either parallel or perpendicular to the tendon or tendon group, the minimum average effective prestress of 0.9 N/mm² is required at every cross section tributary to the tendon or tendon group along the span. Concentrated loads and opening in slabs shall be considered when determining tendon spacing.

9.12.5 In slabs with unbonded tendons, bonded reinforcement shall be provided in accordance with Sections 9.9.4.3 to 9.9.4.5.

9.12.6 Except as permitted in Sec 9.12.7, in slabs with unbonded tendons, a minimum of two 12.7 mm diameter or larger, seven-wire post-tensioned strands shall be provided in each direction at columns, either passing through or anchored within the region bounded by the longitudinal reinforcement of the column. Outside column and shear cap faces, these two structural integrity tendons shall pass under any orthogonal tendons in adjacent spans. Where the two structural integrity tendons are anchored within the region bounded by the longitudinal reinforcement of the column, the anchorage shall be located beyond the column centroid and away from the anchored span.

9.12.7 Prestressed slabs not satisfying Sec 9.12.6 shall be permitted provided they contain bottom reinforcement in each direction passing within the region bounded by the longitudinal reinforcement of the column and anchored at exterior supports as required by Sec 6.5.3.8 Chapter 6. The area of bottom reinforcement in each direction shall be not less than 1.5 times that required by Eq. 6.9.12 as given below.

$$A_{s,min} = \frac{0.25\sqrt{f'_c}}{f_y} b_w d \quad (6.9.12)$$

and not less than $2.1b_w d/f_y$, where b_w is the width of the column face through which the reinforcement passes. Minimum extension of these bars beyond the column or shear cap face shall be equal to or greater than the bar development length required by Sec 8.2.

9.12.8 In lift slabs, bonded bottom reinforcement shall be detailed in accordance with Sec 9.12.9.

9.12.9 In slabs with shear heads and in lift slab construction where it is not practical to pass to the bottom bars, required by bar detailing requirement of Sec 6.5.3.8 Chapter 6, at least two bonded bars or wires in each direction shall pass through the shear head or lifting collar as close to the column as practicable and be continuous or spliced with a Class A splice. At the exterior columns, the reinforcement shall be anchored the spear head or lifting collar.

9.13 Post-Tensioned Tendon Anchorage Zones

9.13.1 Division into Zones

The anchorage zone shall be considered as composed of two zones as described below and shown in Figure 6.9.1.

- (a) The local zone is the rectangular prism (or equivalent rectangular prism for circular or oval anchorages) of concrete immediately surrounding the anchorage device and any confining reinforcement;
- (b) The general zone is the anchorage zone beyond the local zone.

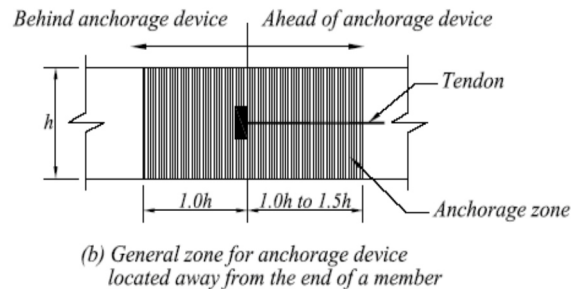
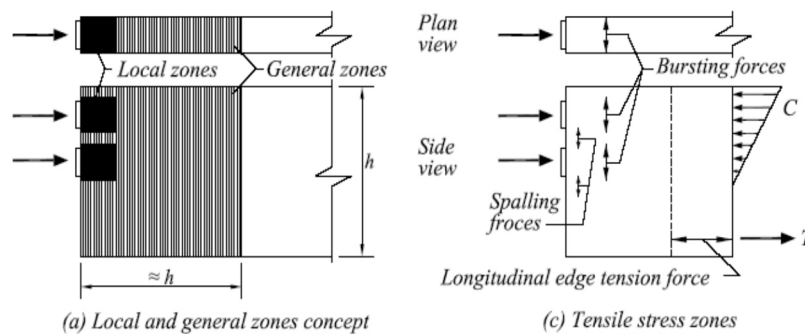


Figure 6.9.1 Anchorage zones

9.13.2 Local Zone

9.13.2.1 Design of local zones shall be based upon the factored prestressing force, P_{pu} and the requirements of Sections 9.9.2 (d)-(f) and 9.13.2.2.

9.13.2.2 For post-tensioned anchorage zone design, a load factor of 1.2 shall be applied to the maximum steel jacking force.

9.13.2.3 Local-zone reinforcement shall be provided where required for proper functioning of the anchorage device.

9.13.3 General Zone

9.13.3.1 Design of general zones shall be based upon the factored prestressing force, P_{pu} and the requirements of Sec 9.4.14.3 b and c.

9.13.3.2 General-zone reinforcement shall be provided where required to resist bursting, spalling, and longitudinal edge tension forces induced by anchorage devices. Effects of abrupt change in section shall be considered.

The general zone requirements of Sec 9.13.3.2 are satisfied by Sections 9.13.4, 9.13.5, and 9.13.6 and whichever one of Sec 9.4.15.2 or Sec 9.4.15.3 or Sec 9.4.16.3 is applicable.

9.13.4 Design Methods

9.13.4.1 The following methods shall be permitted for the design of the general zones of the prestressed components provided that the specific procedures used result in prediction of strength in substantial agreement with results of comprehensive tests:

- (a) Equilibrium-based plasticity models (strut-and-tie models);
- (b) Linear stress analysis (including finite element analysis or equivalent); or
- (c) Simplified equations where applicable.

9.13.4.2 Simplified equations shall not be used where member cross-sections are nonrectangular, where discontinuities in or near the general zone cause deviations in the force flow path, where minimum edge distance is less than 1-1/2 times the anchorage device lateral dimension in that direction, or where multiple anchorage devices are used in other than one closely spaced group.

9.13.4.3 The stressing sequence shall be considered in the design and specified on the design drawings.

9.13.4.4 Three-dimensional effects shall be considered in design and analyzed using three-dimensional procedures or approximated by considering the summation of effects for two orthogonal planes.

9.13.4.5 For anchorage devices located away from the end of the member, bonded reinforcement shall be provided to transfer at least $0.35A_{ps}f_{pu}$ into the concrete section behind the anchor. Such reinforcement shall be placed symmetrically around the anchorage devices and shall be fully developed both behind and ahead of the anchorage devices.

9.13.4.6 Where tendons are curved in the general zone, except for mono-strand tendons in slabs or where analysis shows reinforcement is not required, bonded reinforcement shall be provided to resist radial and splitting forces.

9.13.4.7 Except for mono-strand tendons in slabs or where analysis shows reinforcement is not required, minimum reinforcement with a nominal tensile strength equal to 2 percent of each factored prestressing force shall be provided in orthogonal directions parallel to the back face of all anchorage zones to limit spalling.

9.13.4.8 Tensile strength of concrete shall be neglected in calculations of reinforcement requirements.

9.13.5 Nominal Material Strengths

9.13.5.1 Tensile stress at nominal strength of bonded reinforcement is limited to f_y for nonprestressed reinforcement and to f_{py} for prestressed reinforcement. Tensile stress at nominal strength of unbounded prestressed reinforcement for resisting tensile forces in the anchorage zone shall be limited to $f_{ps} = f_{se} + 70$.

9.13.5.2 Except for concrete confined within spirals or hoops providing confinement equivalent to that corresponding to Eq. 6.9.11, compressive strength in concrete at nominal strength in the general zone shall be limited to $0.7\lambda f'_{ci}$.

9.13.5.3 Concrete strength at transfer (Anchorage): Unless oversize anchorage devices are sized to compensate for the lower compressive strength or the prestressing steel is stressed to no more than 50 percent of the final prestressing force, prestressing steel shall not be stressed until compressive strength of concrete as indicated by tests consistent with the curing of the member, is at least 28 N/mm² for multi-strand tendons or at least 17 N/mm² for single-strand or bar tendons. Compressive strength of concrete at the time of post-tensioning shall be specified in the contract documents and in design drawings.

9.13.6 Detailing Requirements

Selection of reinforcement sizes, spacing, cover, and other details for anchorage zones shall make allowances for tolerances on the bending, fabrication, and placement of reinforcement, for the size of aggregate, and for adequate placement and consolidation of the concrete.

9.14 Design of Anchorage Zones For Monostrand or Single 16 Mm Diameter Bar Tendons

9.14.1 Local Zone Design

Monostrand or single 16 mm diameter or smaller diameter bar anchorage devices and local zone reinforcement shall meet the requirements of ACI 423.7 or the special anchorage device requirements of Sec 9.15.2.

9.14.2 General Zone Design for Slab Tendons

9.14.2.1 For anchorage devices of 12.7 mm diameter or smaller diameter strands in normal weight concrete slabs, minimum reinforcement meeting the requirements of Sections 9.14.2.2 and 9.14.2.3 shall be provided unless a detailed analysis satisfying Sec 9.13.4 shows such reinforcement is not required.

9.14.2.2 Two horizontal bars at least 12 mm diameter in size shall be provided parallel to the slab edge. They shall be permitted to be in contact with the front face of the anchorage device and shall be within a distance of $h/2$ ahead of each device. Those bars shall extend at least 150 mm either side of the outer edges of each device.

9.14.2.3 If the center-to-center spacing of anchorage devices is 300 mm or less, the anchorage devices shall be considered as a group. For each group of six or more anchorage devices, $(n+1)$ hairpin bars or closed stirrups at least No. 10 in size shall be provided, where n is the number of anchorage devices. One hairpin bar or stirrup shall be placed between each anchorage device and one on each side of the group. The hairpin bars or stirrups shall be placed with the legs extending into the slab perpendicular to the edge. The center portion of the hairpin bars or stirrups shall be placed perpendicular to the plane of the slab from $3h/8$ to $h/2$ ahead of the anchorage devices.

9.14.2.4 For anchorage devices not conforming to Sec 9.14.2.1, minimum reinforcement shall be based upon a detailed analysis satisfying Sec 9.13.4.

9.14.3 General Zone Design for Groups of Monostrand Tendons in Beams and Girders

Design of general zones for groups of monostrand tendons in beams and girders shall meet the requirements of Sections 9.13.3 and 9.13.4.

9.15 Design of Anchorage Zones For Multi-Strand Tendons

9.15.1 Local Zone Design

Basic multistrand anchorage devices and the related local and general zone reinforcement shall meet the requirements of AASHTO "LRFD Bridge Design Specifications (SI), 2007", Articles 5.10.9.6, Approximate Stress Analysis and Design, and 5.10.9.7, Design of Local Zones.

Special Anchorage Devices (AASHTO “LRFD Bridge Design Specifications (SI), 2007”, Articles 5.10.9.7.3) requires that special anchorage devices that do not satisfy the requirements specified in Sec 9.15.1, they have been tested by an independent testing agency acceptable to the Engineer and have met the acceptance criteria specified in Articles 10.3.2 and 10.3.2.3.10 of AASHTO LRFD Bridge Construction Specifications.

9.15.2 Special Anchorage Devices

Where special anchorage devices are to be used, supplemental skin reinforcement shall be furnished in the corresponding regions of the anchorage zone, in addition to the confining reinforcement specified for the anchorage device. This supplemental reinforcement shall be similar in configuration and at least equivalent in volumetric ratio to any supplementary skin reinforcement used in the qualifying acceptance tests of the anchorage device.

9.15.3 General Zone Design

Design for general zones for multistrand tendons shall meet the requirements of Sections 9.13.3 to 9.13.5.

9.16 Cold Drawn Low Carbon Wire Prestressed Concrete (Cwpc)

9.16.1 CWPC (Cold drawn wire prestressed concrete) is termed as prestressed concrete technology of Chinese pattern. This technology is a modification of conventional prestressed concrete. In the conventional prestressed concrete high strength wire is used as reinforcement while in Chinese pattern cold drawn low carbon mild steel wire is used as such this technology is named as cold drawn wire prestressed concrete. In short it is termed as CWPC. CWPC technology is a process whereby cold drawn low carbon steel wire has been adopted as reinforcement for pre-fabricated prestressed concrete members of medium and small size as produced by pre tensioning method. On the other hand, large size structural members are produced by conventional prestressed concrete. The main features and advantages of CWPC technology can be summarized as follows:

- (a) Availability (Availability of materials): The raw material of cold drawn wire is made from low carbon mild steel which can be supplied by the local mills. The tensioning process of cold-drawn wire and production of pre-cast members are also simple and very easy to handle.

- (b) **Simplicity (Simplicity of equipment and devices for production):** The cold process of low carbon mild steel and prefabrication process of members are done using simple equipment and devices. The precise and large sized equipment are not necessary. The production techniques of manufacturing members are rather simple.
- (c) **Quality (Good in quality):** The members so manufactured have high crack resistance and stiffness. After pre-tensioning no crack would occur under the service load, thus the wires within the concrete members are well protected. In contrast to conventional reinforced concrete members under the same service conditions, they have comparatively high durability to ensure long term quality.
- (d) **Economy (Low cost):** The cold drawn low carbon steel wire used for prestressing is made of ordinary hot-rolled carbon steel coil rod. This is processed at room temperature through a special wire drawing die. The low carbon coil rods are manufactured by the steel mills; the wires are processed at the construction site or in a prefabrication plant; or are supplied by the cold drawn wire plants as readymade products. By cold drawing the low carbon rod into wires the usable strength is enhanced about twice as much as that of the coil rod. This reduces the amount of steel required in prefabricating prestressed concrete members.
- (e) Therefore, in comparison with conventional reinforced concrete reinforced with common carbon steel, a prestressed concrete member reinforced with cold drawn wire would have saving of steel consumption between 30-40%. Furthermore, since prestressed concrete members have high stiffness a reduction of cross section of members is possible. A considerable amount of concrete can also be saved and hence transportation, handling and erection work can be reduced.
- (f) **Light weight (Lightness in weight):** As already mentioned that the stiffness of prestressed concrete members may be enhanced, the dimension of its cross-section can be reduced correspondingly. This not only results in reduction of concrete volume but also its dead weight which is estimated as 10-30%.

9.16.2 Materials

Basically the materials used in CWPC technology are steel and concrete.

- (a) **Steel:** steel used for CWPC is obtained by cold drawing. Cold drawing as already mentioned is a process of reducing the diameter of the coil rod by forcing it to pass through a conical die. By this process, the usable strength of steel can be increased by nearly 100%.
- (b) **Concrete:** The requirement of concrete in CWPC is same as that of ordinary reinforced concrete.

9.16.3 Design

Similar to other reinforced concrete structures, CWPC structures have a complete set of design specification and computational approaches by which various members of the CWPC can be designed. In the design of prestressed members the function of pre-stressing force and pre-stressing losses should be calculated. CWPC members should be checked for its strength, stability and cracking resistance respectively at different stages including service, manufacturing, handling, erection and construction. In designing members conformity to local specifications should be considered.

Cold drawn low carbon wire conforming to ASTM A615 or equivalent may be permitted for prestressing provided the mechanical requirements shown in Table 6.9.5 are satisfied.

Table 6.9.5: Tensile Strength and Elongation of Cold Drawn Wire

Diameter of wire (mm)	Minimum tensile strength (N/mm ²)	Minimum elongation (percent)
3	650	2.0
4	600	2.5
5	550	3.0

9.17 External Post-Tensioning

9.17.1 Post-tensioning tendons shall be permitted to be external to any concrete section of a member. The strength and serviceability design methods of this Code shall be used in evaluating the effects of external tendon forces on the concrete structure.

9.17.2 External tendons shall be considered as unbonded tendons when computing flexural strength unless provisions are made to effectively bond the external tendons to the concrete section along its entire length.

9.17.3 External tendons shall be attached to the concrete member in a manner that maintains the desired eccentricity between the tendons and the concrete centroid throughout the full range of anticipated member deflection.

9.17.4 External tendons and tendon anchorage regions shall be protected against corrosion, and the details of the protection method shall be indicated on the drawings or in the project specifications.

9.18 Performance Requirement Of Prestressed Concrete Design

9.18.1 Classification of Performance Requirement

After the outline of the member dimensions are determined and the most suitable kind and type of prestressing options are selected at the structural planning stage, the prestressed concrete non-composite and composite structures and members shall satisfy all of the required performances such as safety, serviceability, restorability, durability, reparability, societal and environmental compatibility, etc. at every stage of design, construction and maintenance throughout the design life of the structure. Table 6.9.6 gives the performance requirement of prestressed concrete structures and components and related performance items.

Table 6.9.6: Classification of Performance Requirement for Prestressed Concrete Structures

Performance requirements	Performance item	Examples of check items	Example of verification index
Safety	Structural safety	Resistance of whole structure, components, stability, deformation performance	Stress resultant, stress
	Public safety	Injury to users and third parties	-
Serviceability	Live load operating performance	Soundness and rigidity of structures /members under usual conditions	Floor flatness, deformation of main girder
	User comfort	User-comfort under walking-induced vibrations	Natural frequency of main girders
Restorability	Restorability after earthquake, cyclone, tidal bore, fire, etc.	Level of damage (ease of restoration)	Response value (damage level)/ limit value of performance (damage level)
Durability	Fatigue resistance	Fatigue durability against variable actions	Equivalent stress range/ allowable stress range
	Corrosion resistance	Rust prevention and corrosion protection performance of steel material	Corrosion environment and surface finish, paint specification
	Resistance to material deterioration	Concrete deterioration	Water- cement ratio, cover of concrete
	Maintainability	Ease of maintenance (inspection, ease of repair, etc.) and ease of restoration	-

Performance requirements	Performance item	Examples of check items	Example of verification index
Social and environmental compatibility	Social compatibility	Appropriateness of partial factor (consideration of social importance of structure)	Partial factor, structural factor, etc.
	Economic rationality	Social utility during life cycle of structure	Life cycle cost (LCC), life cycle utility (LTU)
	Environmental compatibility	Noise, vibration, environmental impact, aesthetics, etc.	Noise and vibration levels for surrounding residents, aesthetic reaction to structural shape and color, monumental aspect, etc.
Constructability / workability	Safety during construction	Safety during construction	Stress resultant, stress, deformation
	Initial soundness	Material quality, welding quality, etc.	Material properties, workmanship
	Ease of construction	Ease of fabrication and construction work	User-friendly construction methodology conceived at design stage

9.18.2 Performance Verification Method

- (a) Performance verification shall be based on the partial factor method on the basis of reliability theory and as a standard design procedure, it shall be based on the limit state method.
- (b) In general verification shall be based on design responses to design actions, design limits as determined by design material strengths, and individual partial factors. The performance of the structure shall, in general, be verified using Equations 6.9.13 and 6.9.14:

$$\gamma_i \frac{S_d}{R_d} \leq 1.0 \quad (6.9.13)$$

$$\gamma_i \frac{\sum \gamma_a S(\gamma_f F_k)}{R(f_k/\gamma_m)} \leq 1.0 \quad (6.9.14)$$

Where,

R_d : design resistance

f_k : characteristic value of material strength

γ_m : material factor

γ_b : structural member factor

$R(...)$: function for calculating limit value of structure from material strength

S_d : design response

F_k : individual characteristic value of action

γ_a : structural analysis factor

γ_f : action factor corresponding to each action (load factor)

$S(...)$: function for calculating response value of structure from action

γ_i : structural factor

(c) During design, a verification shall be carried out for every limit state that can be considered.

(d) The flow chart explaining the concept of verification of safety is given in Figure 6.9.2.

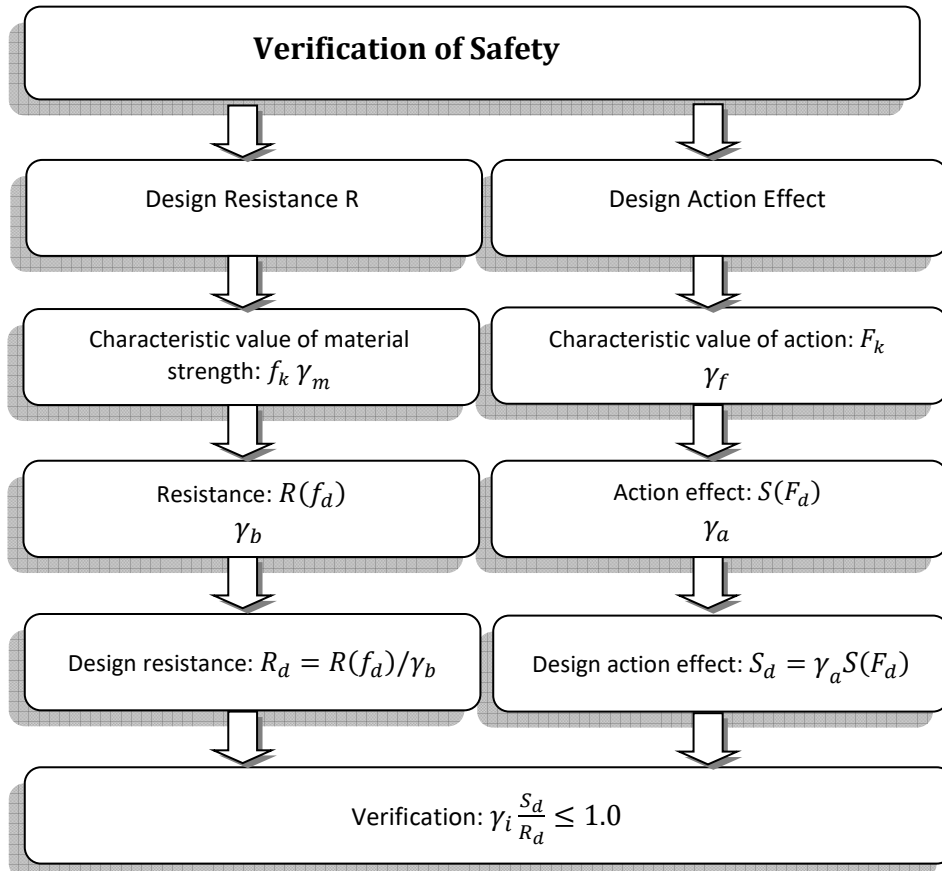


Figure 6.9.2 Flow chart explaining the concept of verification of safety

9.18.3 Partial Factors

(a) Partial factors shall be determined on the concept given (i) and (ii) below.

(i) The material factor, structural member factor, structural analysis factor, and action factor shall be determined in consideration of

- unfavorable deviations from characteristic values,
- uncertainties in computational accuracy, and
- discrepancies between design and practice with respect to actions or structures and materials.

Table 6.9.7 shows the standard values of partial factors.

(ii) The structural factor γ_i shall be determined according to structural importance and also the social and economic impact of the structure reaching its limit state.

Table 6.9.8 shows the standard values of structural factor γ_i for different performance items.

Table 6.9.7: Standard Values of Partial Factors

Performance Item	Action Factor, γ_f	Structural Analysis Factor, γ_a	Material Factor, γ_m	Structural Member Factor, γ_b
Structural safety	1.0 - 1.6	1.0 - 1.1	1.0 - 1.05	1.0 - 1.3
Serviceability (user comfort)	1.0	1.0	1.0 - 1.05	1.0
Durability (fatigue resistance)	1.0 - 1.1	1.0	1.0	1.0 - 1.1

Table 6.9.8: Standard Values of Structural Factors

Performance item	Structural factor γ_i
Structural safety	1.0 - 1.2
Serviceability (User comfort)	1.0
Durability (fatigue resistance)	1.0

Division B: Material and Construction (Sections 9.19 To 9.21)**9.19 Materials****9.19.1 Concrete Ingredients and Applicable ASTM Standards**

Table 6.9.9 shows the list of commonly applicable standards for cement, coarse and fine aggregates, admixtures and mixing water.

Table 6.9.9: Applicable Standards for Cement, Coarse and Fine Aggregates, Admixtures and Water

Material	Designation of the Standard	Title of the Standard
Concrete	ASTM C39	Compression testing of cylindrical concrete specimens
Cement	BDS EN 197-1	Part 1: Composition, specifications and conformity criteria for common cements
Fine and Coarse aggregates	ASTM C136	Standard test method for sieve analysis of fine and coarse aggregates
	ASTM C40	Standard test method for organic impurities in fine aggregates for concrete
	ASTM C142	Clay lumps and friable particles
	ASTM C127	Specific gravity and absorption of coarse aggregate
	ASTM C128	Specific gravity and absorption of fine aggregate
	ASTM C131	Degradation of small-size coarse aggregate by L.A. abrasion test
	ASTM C29	Unit weights and voids in aggregates
	ASTM C70	Surface moisture in fine aggregate Soundness of aggregates by use of sodium sulfate or magnesium sulfate
	ASTM C88	Soundness of aggregates by use of sodium sulfate or magnesium sulfate
	ASTM C227	Alkali reactivity, potential of cement aggregate combinations

Material	Designation of the Standard	Title of the Standard
	ASTM C1260	Potential alkali reactivity of aggregates (Mortar-bar method)
	ASTM D2419	Sand equivalent value of soils and fine aggregate
Admixtures	ASTM C494	Type A – Water reducing Type B – Retarding Type C – Accelerating Type D – Water reducing and retarding Type E – Water reducing and accelerating Type F – Water reducing, high range Type G – Water reducing, high range and retarding Type S – Specific performance admixture
Mixing Water	ASTM C 1602/C1602M	Standard specification for mixing water used in the production of hydraulic cement concrete

9.19.2 Reinforcing Steel and Applicable Standards

Table 6.9.10 shows the types of reinforcing steel with the ASTM and BDS Designation standard specifications.

Table 6.9.10: List of Standards for the Reinforcing Steel

Material	Designation of the Standard	Title of the Standard
Reinforcing Steel	BDS ISO 6935-2	Bangladesh standard, Steel for the reinforcement of concrete, Part 2: Ribbed bars (1st revision)
	ASTM A615/A615M	Standard specifications for deformed and plain carbon steel bars for concrete reinforcement
	ASTM A706/A706M	Standard specifications for low-alloy steel deformed and plain carbon steel bars for concrete reinforcement
	A775/A775M	Standard Specification for Epoxy-Coated Steel Reinforcing Bars

Material	Designation of the Standard	Title of the Standard
	A884/A884M	Standard Specification for Epoxy-Coated Steel Wire and Welded Wire Reinforcement
	A934/A934M	Standard Specification for Epoxy-Coated Prefabricated Steel Reinforcing Bars
	ASTM A996/A996M	Specification for Axle Steel Deformed and Plain Bars for Concrete Reinforcement
	ASTMA996/A996M	Specification for Rail Steel Deformed and Plain Bars for Concrete Reinforcement" Including Supplementary Requirements S1

9.19.3 Prestressing Steel and Applicable ASTM Standards

Table 6.9.11 shows the types of high tensile prestressing steel and cold drawn wires used for prestressing, with the ASTM Designation standard specifications.

Table 6.9.11: List of Standards for the Prestressing Steel

Material	Designation of the Standard	Title of the Standard
Prestressing Steel	A416/A416M	Standard Specification for Steel Strand, Uncoated Seven-Wire for Prestressed Concrete
	A421/A421M	Standard Specification for Uncoated Stress-Relieved Steel Wire for Prestressed Concrete
	ASTM A648	Standard specification for steel, wire, hard drawn for prestressing concrete pipe
	A722/A722M	Standard Specification for Uncoated High-Strength Steel Bars for Prestressing Concrete

9.20 Construction of Prestressed Concrete Structures

9.20.1 Corrosion Protection for Unbonded Tendons

9.20.1.1 Unbonded prestressing steel shall be encased with sheathing. The prestressing steel shall be completely coated and the sheathing around the prestressing steel filled with suitable material to inhibit corrosion.

9.20.1.2 Sheathing shall be watertight and continuous over entire length to be unbonded.

9.20.1.3 For applications in corrosive environments, the sheathing shall be connected to all stressing, intermediate and fixed anchorages in a water tight fashion.

9.20.1.4 Unbonded single-strand tendons shall be protected against corrosion in accordance with ACI 423.7.

9.20.2 Post-tensioning Ducts

9.20.2.1 Ducts for grouted tendons shall be mortar- tight and nonreactive with concrete, prestressing steel, grout, and corrosion inhibitor.

9.20.2.2 Ducts for grouted single-wire, single-strand, or single-bar tendons shall have an inside diameter at least 6 mm larger than the prestressing steel diameter.

9.20.2.3 Ducts for grouted multiple wire, multiple strand, or multiple bar tendons shall have an inside cross-sectional area at least two times the cross-sectional area of the prestressing steel.

9.20.2.4 Ducts shall be maintained free of ponded water if members to be grouted are exposed to temperatures below freezing prior to grouting.

9.20.3 Grout for Bonded Tendons

9.20.3.1 Grout shall consist of Portland cement and water; or Portland cement, sand, and water.

9.20.3.2 Materials for grout shall conform to Sections 9.20.3.3 to 9.20.3.5.

9.20.3.3 Portland cement shall conform to Sec 9.19.1.

9.20.3.4 Water shall conform to Sec 9.19.1.

9.20.3.5 Sand, if used, shall conform to Sec 9.19.1 except that gradation shall be permitted to be modified as necessary to obtain satisfactory workability.

9.20.3.6 Admixtures conforming to Sec 9.19.1 and known to have no injurious effects on grout, steel, or concrete shall be permitted. Calcium chloride shall not be used.

9.20.4 Selection of Grout Proportions

9.20.4.1 Proportions of materials for grout shall be based on either (a) or (b) below.

- (a) Results of tests on fresh and hardened grout prior to beginning grouting operations; or
- (b) Prior documented experience with similar materials and equipment and under comparable field conditions.

9.20.4.2 Cement used in the Work shall correspond to that on which selection of grout proportions was based.

9.20.4.3 Water content shall be minimum necessary for proper pumping of grout; however, water-cement ratio shall not exceed 0.45 by weight.

9.20.4.4 Water shall not be added to increase grout flowability that has been decreased by delayed use of the grout.

9.20.5 Mixing and Pumping of Grout

9.20.5.1 Grout shall be mixed in equipment capable of continuous mechanical mixing and agitation that will produce uniform distribution of materials, passed through screens, and pumped in a manner that will completely fill the ducts.

9.20.5.2 Temperature of members at time of grouting shall be above 2°C and shall be maintained above 2°C until field-cured 50 mm cubes of grout reach a minimum compressive strength of 5.5 N/mm².

9.20.5.3 Grout temperatures shall not be above 32°C during mixing and pumping.

9.20.6 Protection for Prestressing Steel During Welding

Burning or welding operations in the vicinity of prestressing steel shall be performed so that prestressing steel is not subject to excessive temperatures, welding sparks, or ground currents.

9.20.7 Application and Measurement of Prestressing Force

9.20.7.1 Prestressing force shall be determined by both of (a) and (b):

(a) Measurement of steel elongation. Required elongation shall be determined from average load-elongation curves for the prestressing steel used;

(b) Observation of jacking force on a calibrated gage or load cell or by use of a calibrated dynamometer.

Cause of any difference in force determination between (a) and (b) that exceeds 5 percent for pretensioned elements or 7 percent for post-tensioned construction shall be ascertained and corrected.

9.20.7.2 Where the transfer of force from the bulk- heads of pretensioning bed to the concrete is accomplished by flame cutting prestressing steel, cutting points and cutting sequence shall be predetermined to avoid undesired temporary stresses.

9.20.7.3 Long lengths of exposed pretensioned strand shall be cut near the member to minimize shock to concrete.

9.20.7.4 Total loss of prestress due to unreplaced broken prestressing steel shall not exceed 2 percent of total prestress.

9.20.8 Post-tensioning Anchorages and Couplers

9.20.8.1 Anchorages and couplers for bonded and unbonded tendons shall develop at least 95 percent of the f_{pu} when tested in an unbonded condition, without exceeding anticipated set. For bonded tendons, anchorages and couplers shall be located so that 100 percent of f_{pu} shall be developed at critical sections after the prestressing steel is bonded in the member.

9.20.8.2 Couplers shall be placed in areas approved by the licensed design professional and enclosed in housing long enough to permit necessary movements.

9.20.8.3 In unbonded construction subject to repetitive loads, attention shall be given to the possibility of fatigue in anchorages and couplers.

9.20.8.4 Anchorages, couplers, and end fittings shall be permanently protected against corrosion.

9.21 Performance Requirement of Material

9.21.1 The fundamental performance requirement of materials forming the structure is that they should be able to resist actions such as the various loadings to which the structure is exposed.

9.21.2 Materials forming the structure should not reach unexpected limit states as a result of deterioration phenomena during the working life of the structure.

9.21.3 Materials-related energy consumption and CO₂ discharges should be minimized, while recyclability should be high.

Any materials that escape into the surrounding environment during construction and service should not have a strong impact on human beings, animals and plants.

Commentary:

Corresponding to design requirements, the materials should be evaluated to ensure that their properties are suitable with respect to strength (tensile, compressive and shear), deformation (e.g. elastic modulus), heat resistance and water tightness.

The characteristic values obtained from the tests, complying appropriate BDS, ASTM, BS, or equivalent standards, on such specimens should be converted to suit the design calculation models using appropriate conversion factors or functions. The characteristic value of material strength f_k is calculated from test results using Eq. 6.9.15.

$$f_k = f_m - k\sigma \quad (6.9.15)$$

Where, f_m : mean of test values, σ : standard deviation of test values, and k : coefficient of variance. The coefficient k is determined from the probability of obtaining a test value less than the characteristic value and the probability distribution of test results. The 5% fractile value is often taken as the characteristic value. In this case, the value of k is 1.64 if the normal distribution is assumed for the test values.

At the structural design stage, verification shall be performed so that response value is less than or equal to the limit value of performance throughout both construction period and working life. At the end of construction stage, just completed structure shall fulfill the all required performances considered in its design.

Division C : Maintenance (Sections 9.22 To 9.27)

9.22 General

If the prestressed concrete structure is designed and constructed in accordance with the appropriate concepts described in Part I and II of this Chapter, based on which the durability is checked by verifying the performance requirements of the concrete and its constituent materials, it is not likely that structural deterioration would become so significant as to degrade the performance of the structure. On the other hand it is not easy to estimate the performance degradation process of the structure during its service life accurately. Also, it is difficult to completely avoid construction defects at all construction stages. Therefore, the new structure should be appropriately maintained by routine and regular inspections, based on an adequate maintenance plan formulated at the design stage.

For existing structures, deterioration may be evident in some cases, with the performance having been degraded. The defects of such structures should be accurately assessed and identified as initial defects, damage, or deteriorations. Major causes for such defects should be identified subsequently so that appropriate remedial actions can be selected. The initial defects and damage should be treated promptly and appropriately including emergency treatments. When the deterioration that would degrade the performance is evident, the deterioration mechanisms should be identified and appropriate maintenance, carried out based on the results of deterioration prediction and performance degradation evaluation.

9.23 Classification of Maintenance Action

Maintenance actions shall be classified into different categories depending on such factors as the importance of the structure, design life, impact on a third party, environmental conditions, ease of maintenance, and cost.

In the view of the above, four categories are recommended for the classifications of the maintenance actions:

9.23.1 Category A : Preventive Maintenance

Maintenance to prevent deterioration which would otherwise lead to unsatisfactory structural performance. Category A structures are those

- for which remedial actions are difficult to take after deterioration becomes apparent;
- of which deterioration must not be apparent;
- having a long design life.

Structures in this category generally have a high degree of importance which in many cases require monitoring.

9.23.2 Category B : Corrective Maintenance

Maintenance to restore the performance level and/or to reduce the rate of deterioration so as to maintain satisfactory structural performance. Category B structures are those for which

- remedial measures can be taken after deterioration becomes apparent;
- apparent deterioration causes no appreciable inconvenience.

9.23.3 Category C : Observational Maintenance

Maintenance in which visual inspection is necessary without any remedial action regardless of the deterioration level. Category C structures are those

- for use as long as they are usable;
- for which ensuring safety from threats posed to third parties is the only requirement.

9.23.4 Category D : Indirect Maintenance

Maintenance in which no direct inspection is necessary or possible. Category D structures are those for which direct inspection is extremely difficult. For these reasons, non-inspection maintenance after the initial inspection is carried out not as routine or regular inspection, but as extraordinary inspection following natural disasters, accidents, etc.

9.24 Maintenance Record

Records, drawings and related documents prepared during the time of planning, design and construction shall be referred to and made use of while developing an appropriate methodology for maintenance covering inspection and repairs.

Commentary:

A thorough study of the planning, design and construction related documents often provide insights into the inherent weaknesses of the structure which in turn often serve as pointers for further detailed inspection and/or repairs.

Furthermore, a clear record should be kept of the difficulties encountered, remedial actions taken and any deviation from the design drawings. These record also serve as a valuable reference in the design and construction of similar structures and their subsequent inspections.

9.25 Inspection

9.25.1 General

On the basis of the methods used in the frequency and timing, inspection shall be classified as initial inspection, routine inspection, regular inspection, detailed inspection, extraordinary inspection, and monitoring.

9.25.2 Initial Inspection

Initial inspection is intended to examine whether the structure is adequately constructed. It also allows the collection of basic data for initiating a maintenance program. Initial inspection shall also be carried out just after the completion of remedial actions.

Initial inspection should cover the external appearance of the structure, variation of concrete quality, existence of construction defects, construction errors on reinforcing and prestressing bar arrangement, and so on.

9.25.3 Routine Inspections

It shall be carried out on a routine basis at certain intervals without making any specific effort to identify signs of deterioration, if any, and the time of their first appearance. The exact tools to be used and the frequency of such inspections may be decided on the basis of such factors as the likely mechanisms of such deterioration, environmental conditions, importance of the structure, and the maintenance action classification.

A routine inspection should cover the external appearance of the structure including cracks, spalling, delamination, color changes, rust stain from reinforcement, and isolation of free lime from concrete.

9.25.4 Regular Inspection

It shall be carried out at regular intervals using appropriate tools to identify signs of deterioration and the time of their first appearance. Efforts shall be made during a regular inspection to observe the structure closely to obtain details which will be difficult to gather during a routine inspection.

Visual inspection and/or hammering inspection are carried out mainly to obtain more details on the items inspected in a routine inspection. In addition, inspections by using appropriate non-destructive tests or taking concrete cores etc. can be effectively combined with the visual inspection.

9.25.5 Detailed Inspection

Detailed inspection shall be done when

- (a) some signs of deterioration or a change in the performance level are observed during a routine and/or regular inspection;
- (b) it is difficult to obtain reliable and accurate information during a routine and/or regular inspection;
- (c) it is found that the structural integrity of the structure has been adversely affected by the extent of the deterioration;
- (d) more detailed information is required before deciding on the necessity and scope for undertaking a major repair, rehabilitation or strengthening work.

9.25.6 Extraordinary Inspection

It shall be carried out after a structure has been subjected to an accidental load to assess the extent of the damage and the need for remedial actions. Such accidental loads may include those caused by an earthquake, storm, flood, fire, explosion, etc.

9.26 Monitoring

The deterioration and/or performance of the concerned structure as determined in 9.6.2, shall be monitored, through continuous recording of the appropriate data, together with routine and regular inspections, so that the appropriate remedial actions can be taken before the deterioration becomes detrimental to the appearance and other performance of the structure.

9.26.1 Deterioration Mechanism and Prediction**9.26.1.1 General**

The prevailing state of the concerned structure shall be evaluated as properly as possible according to the inspection results, design and construction records, environmental conditions, and any other relevant information. Then when any deterioration is found, the possible causes of the deterioration and the corresponding mechanism can be appropriately estimated.

9.26.1.2 Identification of deterioration mechanisms

Deterioration of a structure is caused by the environmental actions and loading conditions. Environment-oriented deterioration includes carbonation-induced deterioration, chloride-induced deterioration, chemical attack, alkali-aggregate reaction, etc. On the other hand external force-oriented deterioration includes fatigue, excessive loading, and differential settlement of the support.

9.26.1.3 Deterioration factors

Deterioration factors may be classified into those

- (a) external to structures such as temperature, humidity and any other environmental characteristics; and
- (b) internal to the structure such as design parameters and quality control during construction.

Commentary:

Design factors include the geometry of the members/ segments, crack width specifications, concrete cover to reinforcing bar and prestressing steel/ducts, and design strength. Construction factors include material selection, mix proportions, transportation, placement, and curing methods.

9.26.1.4 Determination of deterioration levels and rates

The level of deterioration and/or performance shall be determined based on the results of inspections and simulations using appropriate models for the mechanisms of deterioration.

The following features appearing on the surface of the structure may be used for evaluating the degree of deterioration and the level of performance:

- (a) crack pattern, length and width;
- (b) the extent of delamination, peeling and spalling of concrete cover, and scaling and degradation areas;
- (c) abnormal hammer tapping sound and the extent of abnormality;
- (d) presence and degree of exudation of rust and efflorescence and water leakage.

9.26.2 Evaluation and Decision Making

9.26.2.1 General

In general, the deterioration and performance degradation of a structure progress monotonically. The decision, therefore, should be made based on the evaluation outcome of the performance of the structure at the time of inspection and at the end of its design life.

9.26.2.2 Threshold level

The threshold level of the structure's degraded performance shall be specified in accordance with the requirements of safety, functionality, appearance, societal friendliness and such other factors, taking into consideration the type, importance and maintenance level of the structure and the environmental conditions.

9.26.2.3 Evaluation of inspection results

The results from routine and regular inspections shall be evaluated and a decision shall be made whether a detailed inspection is required or otherwise.

The results from the detailed and/or extraordinary inspections shall be evaluated and a decision shall be made whether a remedial action is required or otherwise.

Immediate remedial actions shall be taken in cases where deterioration, damage and/or initial defects are found to be hazardous to third parties.

9.27 Remedial Action

9.27.1 General

A remedial action on a deteriorated structure shall be taken on the basis of the inspection results, importance of the structure, maintenance classification, and the threshold level of deterioration and/or performance.

Commentary:

Repair and strengthening are the main techniques of remedial actions of which details are described in Sections 9.2.7.3 and 9.2.7.4 respectively. The following measures are also included in the remedial actions.

Intensified inspection: inspection may be carried out by suitably increasing one or more of the following: frequency of inspection, number of inspection items, and the locations for inspection.

Usage restriction: suitable restriction shall be imposed on the maximum live load that the structure may carry, depending on the level of deterioration observed.

Functional improvement or restoration: this may include an appearance improvement that beautifies a structure with suitably painting or placing additional concrete, and so on.

Dismantling and removal: in a case when the deterioration of a structure is too severe for its structural performance to be sufficiently restored, and dismantling or the removal is one of the choices as the remedial measures.

Special care for emergency: when a deteriorated structure poses an immediate threat to the environment, its users, or third parties, suitable emergency action shall be taken immediately.

9.27.2 Selection of Remedial Action

Selection of methods and materials suitable for the relevant deterioration mechanism and degree of performance degradation is particularly important for measures for which wide varieties of methods and materials are available. Care should be taken as the method of restoring the performance may vary depending on the deterioration mechanism, even if the level of performance is the same.

9.27.3 Repair

9.27.3.1 General

Repair of a structure refers to the remedial action taken to prevent or slow down its further deterioration and reduce the possibility of damage to its users or third parties.

Types of repair include (i) repair of defects such as cracking and peeling; (ii) removal of concrete damaged by deterioration due to carbonation and such like; (iii) surface coating to prevent re-intrusion of hazardous substances.

9.27.3.2 Preparation and execution

A complete plan for the repair work including methods of repair, materials to be used, and tests to ensure the quality of work, shall be developed before the repair work commences.

Repair works shall be carried out with minimum disturbances to the surrounding environment. Necessary tests to ensure the quality of the repair work shall be carried out. Detailed record of the repair work shall be maintained for future reference.

9.27.3.3 Methods and materials

Some current repair methods and associated materials are

- crack repair by injecting epoxy;
- section repair including patching using polymer cement mortar;
- surface protection by resin or mortar;
- cathodic protection;
- re-alkalization;
- de-salination, wherever required.

Commentary:

Development of a repair plan comprises the selection of a repair method suitable for the deterioration mechanism, establishment of the required repair level, and decisions on the repair policy, specifications for the repair materials, sectional dimensions after repair, and execution methods.

9.27.4 Strengthening

9.27.4.1 General

Strengthening of a structure refers to the remedial action taken to restore or improve its structural properties including load carrying capacity and stiffness, to a level which is equal to or higher than that of the original design.

Commentary:

Strengthening methods include (i) replacement of members; (ii) an increase in the cross-sectional area of concrete; (iii) addition of members; (iv) an increase of the support points; (v) addition of strengthening members; (vi) external prestressing, etc.

9.27.4.2 Preparation and execution

Strengthening of a structure shall be preceded by a thorough investigation of its deterioration considering such factors as the remaining design life, deterioration mechanism, possible causes and extent of deterioration, the remaining and desired load-carrying capacity or stiffness, importance of the structure, maintenance classification, and any remedial actions taken previously.

A complete plan for the strengthening work including design calculations, methods of strengthening, materials to be used, and tests to ensure quality of the work, shall be developed before work commences.

Strengthening work shall be carried out with minimum disturbance to the surrounding environment and the service condition of the structure.

9.27.4.3 Methods and materials

Some current methods and associated materials for strengthening are

- external bonding viz plate or sheet bonding and over or under-laying using steel or carbon sheets;
- external prestressing using additional tension cables;
- addition of girders, braces and/or supports;
- replacement of members;
- seismic isolation.

Commentary:

When selecting a strengthening method, it is necessary to consider effects of strengthening, constructability, cost-effectiveness, and impact on the community/ environment during execution. It is also important to consider the ease of maintenance after strengthening and any influence on the landscape.

9.27.5 Record

9.27.5.1 General

Records shall be kept and preserved for future reference. Such records shall include details concerning the design, inspection and evaluation procedures, plans and execution of any repair and/or strengthening work undertaken, and other such information.

9.27.5.2 Preservation

The maintenance records of a structure shall be preserved while the structure remains in service. It is also desirable that such records be preserved for an indefinite period as a useful reference for the construction and maintenance of other similar structures.

Commentary:

It is important to devise a format that makes it easy to understand the history of a structure by simply referring to records. The records should be made accessible at all times.

9.27.5.3 Method and item of recording

Records shall be kept in an easy-to-understand format.

The items to be recorded shall include references to concerned agencies, drawings, immediate and nearby environment, classification of structure, results of deterioration rate estimation, results of any inspections carried out, evaluation of the structure, and details of the plan and actual execution of remedial and other actions.

PART VI
Chapter 10
Steel Structures

10.1 General Provisions for Structural Steel Buildings and Structures

This Section states the scope of the Specification, summarizes referenced Specification, code, and standard documents, and provide requirements for materials and contract documents.

10.1.1 Scope

The specification contained in Chapter 10 Part 6 of this Code sets forth criteria for the design, fabrication, and erection of structural steel buildings and other structures, where other steel-structures are defined as those structures designed, fabricated, and erected in a manner similar to steel-buildings, with building-like vertical and lateral load resisting elements. Where conditions are not covered by this specification, designs are permitted to be based on tests or analysis, subject to the approval of the authority having jurisdiction. Alternate methods of analysis and design shall be permitted, provided such alternate methods or criteria are acceptable to the authority having jurisdiction.

10.1.1.1 Low-seismic applications

When the seismic response modification coefficient, R (as specified in Chapter 2 Part 6) is taken equal to or less than 3, the design, fabrication, and erection of structural-steel-framed buildings and other steel-structures shall comply with this specification except that such structures need not to comply with the specifications set forth in Sec 10.20 Seismic Provisions.

10.1.1.2 High-seismic applications

When the seismic response modification coefficient, R (as specified in Chapter 2 Part 6) is taken greater than 3, the design, fabrication and erection of structural-steel-framed buildings and other structures shall comply with the requirements in the Sec 10.20 Seismic Provisions, in addition to the provisions of other sections (whichever applicable) this specification.

10.1.2 Symbols, Glossary and Referenced Specifications, Codes and Standards

10.1.2.1 Symbols

The Section or Table number in the right-hand column refers to where the symbol is first used.

<u>Symbol</u>	<u>Meaning</u>	<u>Section</u>
A	Column cross-sectional area, mm ²	10.10.10.6
A	Total cross-sectional area of member, mm ²	10.5.7.2

Symbol	Meaning	Section
A_{BM}	Cross-sectional area of the base metal, mm ²	10.10.2.4
A_b	Nominal unthreaded body area of bolt or threaded part, mm ²	10.10.3.6
A_b	Cross-sectional area of a horizontal boundary element (HBE), mm ²	10.20.17.2.1
A_{bi}	Cross-sectional area of the overlapping branch, mm ²	10.11.2.3
A_{bj}	Cross-sectional area of the overlapped branch, mm ²	10.11.2.3
A_c	Cross-sectional area of a vertical boundary element (VBE), mm ²	10.20.17.2.1
A_D	Area of an upset rod based on the major thread diameter, mm ²	Table 6.10.10
A_e	Effective net area, mm ²	10.4.2
A_{eff}	Summation of the effective areas of the cross section based on the reduced effective width, b_e , mm ²	10.5.7.2
A_f	Flange area, mm ²	10.20.8
A_{fc}	Area of compression flange	10.7.3.1
A_{fg}	Gross tension flange area, mm ²	10.6.13.1
A_{fn}	Net tension flange area, mm ²	10.6.13.1
A_{ft}	Area of tension flange, mm ²	10.7.3.1
A_g	Gross area of member, mm ²	10.2.3.13
A_g	Gross area of section based on design wall thickness, mm ²	10.7.6
A_g	Chord gross area, mm ²	10.11.2.2
A_g	Gross area, mm ²	10.20.9
A_{gv}	Gross area subject to shear, mm ²	10.10.4.3
A_n	Net area of member, mm ²	10.2.3.13
A_{nt}	Net area subject to tension, mm ²	10.10.4.3
A_{nv}	Net area subject to shear, mm ²	10.10.4.2

<u>Symbol</u>	<u>Meaning</u>	<u>Section</u>
A_{pb}	Projected bearing area, mm ²	10.10.7
A_{sc}	Area of the yielding segment of steel core, mm ²	10.20.16
A_{sf}	Shear area on the failure path, mm ²	10.4.5.1
A_{st}	Stiffener area, mm ²	10.7.3.3
A_{st}	Area of link stiffener, mm ²	10.20.15
A_t	Net tensile area, mm ²	10.17.4
A_w	Web area, the overall depth times the web thickness, dt_w , mm ²	10.7.2.1
A_w	Effective area of the weld, mm ²	10.10.2.4
A_w	Link web area, mm ²	10.20.15
A_{wi}	Effective area of weld throat of any i^{th} weld element, mm ²	10.10.2.4
A_1	Area of steel concentrically bearing on a concrete support, mm ²	10.10.8
A_2	Maximum area of the portion of the supporting surface that is geometrically similar to and concentric with the loaded area, mm ² .	10.10.8
B	Factor for lateral-torsional buckling in tees and double angles	10.6.9.2
B	Overall width of rectangular HSS member, measured 90° to the plane of connection, mm.	10.11.1.1, Table 6.10.2
B	Overall width of rectangular HSS main member, measured 90° to the plane of the connection, mm.	10.11.2.1, 10.11.3.1
B_b	Overall width of rectangular HSS branch member, measured 90° to the plane of the connection, mm.	10.11.2.1, 10.11.3.1
B_{bi}	Overall branch width of the overlapping branch	10.11.2.3
B_{bj}	Overall branch width of the overlapped branch	10.11.2.3
B_p	Width of plate, measure 90° to the plane of the connection, mm.	10.11.1.1
B_p	Width of plate, transverse to the axis of the main member, mm.	10.11.2.3

Symbol	Meaning	Section
B_1, B_2	Factors used in determining M_u for combined bending and axial forces when first-order analysis is employed	10.3.2.1
C	HSS torsional constant	10.8.3.1
C_a	Ratio of required strength to available strength	Table 6.10.8
C_b	Lateral-torsional buckling modification factor for nonuniform moment diagrams when both ends of the unsupported segment are braced	10.6.1
C_d	Coefficient relating relative brace stiffness and curvature	10.19.3.1, 10.20.9
C_d	Deflection amplification factor	P.2
C_f	Constant based on stress category, given in Table 6.10.14	10.17.3
C_m	Coefficient assuming no lateral translation of the frame	10.3.2.1
C_p	Ponding flexibility coefficient for primary member in a flat roof	10.16.1
C_r	Coefficient for web sidesway buckling	10.10.10.4
C_r	Parameter used for determining the approximate fundamental period	P.2
C_s	Ponding flexibility coefficient for secondary member in a flat roof	10.16.1
C_v	Web shear coefficient	10.7.2.1
C_w	Warping constant, mm ⁶	10.5.4
D	Nominal dead load	10.16.2
D	Dead load due to the weight of the structural elements and permanent features on the building, N.	10.20.9
D	Outside diameter of round HSS, mm.	Table 6.10.8
D	Outside diameter of round HSS member, mm.	Table 6.10.1
D	Outside diameter of round HSS member, mm.	10.11.1.1
D	Outside diameter of round HSS main member, mm.	10.11.2.1
D	Outside diameter of round HSS main member, mm.	10.11.3.1
D	Outside diameter, mm.	10.5.7.2

<u>Symbol</u>	<u>Meaning</u>	<u>Section</u>
D	Chord diameter, mm.	10.11.2.2
D_b	Outside diameter of round HSS branch member,mm.	10.11.2.1
D_b	Outside diameter of round HSS branch member,mm.	10.11.3.1
D_s	Factor used in Eq. 6.10.144, dependent on the type of transverse stiffeners used in a plate girder	10.7.3.3
D_u	In slip-critical connections, a multiplier that reflects the ratio of the mean installed bolt pretension to the specified minimum bolt pretension	10.10.3.8
E	Earthquake load	10.20.4
E	Effect of horizontal and vertical earthquake-induced loads	10.20.9
E	Modulus of elasticity of steel, $E = 200,000$ MPa	10.20.8
E	Eccentricity in a truss connection, positive being away from the branches, mm.	10.11.2.1
E	Modulus of elasticity of steel = 200000 MPa	Table 6.10.1
E_c	Modulus of elasticity of concrete, MPa.	10.18.2.3
E_{cm}	Modulus of elasticity of concrete at elevated temperature, MPa	
EI	Flexural elastic stiffness of the chord members of special segment, (N-mm ²)	10.20.12
E_m	Modulus of elasticity of steel at elevated temperature, MPa.	10.18.2.3
F_a	Available axial stress at the point of consideration, MPa.	10.8.2
F_{BM}	Nominal strength of the base metal per unit area, MPa.	10.10.2.4
F_{BW}	Available flexural stress at the point of consideration about the major axis, MPa.	10.8.2
F_{bz}	Available flexural stress at the point of consideration about the minor axis, MPa.	10.8.2
F_c	Available stress, MPa.	10.11.2.2
F_{cr}	Critical stress, MPa.	10.5.3
F_{cr}	Buckling stress for the section as determined by analysis, MPa.	10.6.12.2

Symbol	Meaning	Section
F_{cry}	Critical stress about the minor axis, MPa.	10.5.4
F_{crz}	Critical torsional buckling stress, MPa.	10.5.4
F_e	Elastic critical buckling stress, MPa.	10.3.1.3
F_{ex}	Elastic flexural buckling stress about the major axis, MPa.	10.5.4
F_{EXX}	Electrode classification number, MPa.	10.10.2.4
F_{ey}	Elastic flexural buckling stress about the minor axis, MPa.	10.5.4
F_{ez}	Elastic torsional buckling stress, MPa.	10.5.4
F_L	A calculated stress used in the calculation of nominal flexural strength, MPa.	Table 6.10.1
F_n	Nominal torsional strength	10.8.3.3
F_n	Nominal tensile stress F_{nt} , or shear stress, F_{nv} , from Table 6.10.10, MPa.	10.10.3.6
F_{nt}	Nominal tensile stress from Table 6.10.10, MPa.	10.10.3.7
F'_{nt}	Nominal tensile stress modified to include the effects of shearing stress, MPa.	10.10.3.7
F_{nv}	Nominal shear stress from Table 6.10.10, MPa.	10.10.3.7
F_{SR}	Design stress range, MPa.	10.17.3
F_{TH}	Threshold fatigue stress range, maximum stress range for indefinite design life from Table 6.10.14, MPa.	10.17.1
F_u	Specified minimum tensile strength of the type of steel being used, MPa.	10.4.2
F_u	Specified minimum tensile strength of the connected material, MPa.	10.10.3.10
F_u	Specified minimum tensile strength of HSS material, MPa.	10.11.1.1
F_u	Specified minimum tensile strength of HSS material, MPa.	10.11.2.1
F_u	Ultimate strength of HSS member, MPa.	10.11.3.1

Symbol	Meaning	Section
F_u	Specified minimum tensile strength, MPa.	10.20.6
F_{um}	Specified minimum tensile strength of the type of steel being used at elevated temperature, MPa.	10.18.2
F_w	Nominal strength of the weld metal per unit area, MPa.	10.10.2.4
F_{wi}	Nominal stress in any i^{th} weld element, MPa.	10.10.2.4
F_{wix}	x component of stress F_{wi} , MPa.	10.10.2.4
F_{wiy}	y component of stress F_{wi} , MPa.	10.10.2.4
F_y	Specified minimum yield stress of the type of steel being used, MPa. As used in this Specification, “yield stress” denotes either the specified minimum yield point (for those steels that have a yield point) or specified yield strength (for those steels that do not have a yield point)	10.20.6, Table 6.10.1
F_y	Specified minimum yield stress of the compression flange, MPa.	10.15.3
F_y	Specified minimum yield stress of the column web, MPa.	10.10.10.6
F_y	Specified minimum yield stress of HSS member material, MPa.	10.11.1.1
F_y	Specified minimum yield stress of HSS main member material, MPa.	10.11.2.1
F_y	Specified minimum yield stress of HSS main member, MPa.	10.11.3.1
F_{yb}	Specified minimum yield stress of HSS branch member material, MPa.	10.11.2.1
F_{yb}	Specified minimum yield stress of HSS branch member, MPa.	10.11.3.1
F_{yb}	F_y of a beam, MPa.	10.20.9
F_{yc}	F_y of a column, MPa.	10.20.9
F_{ybi}	Specified minimum yield stress of the overlapping branch material, MPa.	10.11.2.3
F_{yf}	Specified minimum yield stress of the flange, MPa.	10.10.10.1
F_{ym}	Specified minimum yield stress of the type of steel used at elevated temperature, MPa.	10.18.2
F_{yp}	Specified minimum yield stress of plate, MPa.	10.11.1.1

Symbol	Meaning	Section
$F_{y_{sc}}$	Specified minimum yield stress of the steel core, or actual yield stress of the steel core as determined from a coupon test, MPa.	10.20.16
$F_{y_{st}}$	Specified minimum yield stress of the stiffener material, MPa.	10.7.3.3
F_{y_w}	Specified minimum yield stress of the web, MPa.	10.10.10.2
G	Shear modulus of elasticity of steel = 77 200 MPa.	10.5.4
G	Gap between toes of branch members in a gapped K-connection, neglecting welds, mm.	10.11.2.1
H	Flexural constant	10.5.4
H	Overall height of rectangular HSS member, measured in the plane of connection, mm.	10.11.1.1
H	Overall height of rectangular HSS main member, measured in plane of connection, mm.	10.11.2.1
H	Overall height of rectangular HSS main member, measured in plane of connection, mm.	10.11.3.1
H	Overall height of rectangular HSS member, measured in the plane of connection, mm.	Table 6.10.2
H	The load length parameter, applicable only to rectangular HSS; the ratio of the length of contact of the branch with the chord in the plane of the connection to the chord width = N/B , where, $N = H_b/\sin\theta$	10.11.2.1
H	Height of story, which may be taken as the distance between the centerline of floor framing at each of the levels above and below, or the distance between the top of floor slabs at each of the levels above and below, mm	10.20.8
H_b	Overall height of rectangular HSS branch member, measured in the plane of the connection, mm.	10.11.3.1
H_b	Overall height of rectangular HSS branch member, measured in the plane of the connection, mm.	10.11.2.1
H_{bi}	Overall depth of the overlapping branch	10.11.2.3
ΣH	Story shear produced by the lateral forces used to compute Δ_H , N.	10.3.2.1
I	Moment of inertia in the place of bending, mm ⁴ .	10.3.2.1

Symbol	Meaning	Section
I	Moment of inertia about the axis of bending, mm ⁴ .	10.14.3
I	Moment of inertia, mm ⁴	10.20.12
I_c	Moment of inertia of a vertical boundary element (VBE) taken perpendicular to the direction of the web plate line, mm ⁴	10.20.17
I_d	Moment of inertia of the steel deck supported on secondary members, mm ⁴	10.16.1
I_p	Moment of inertia of primary members, mm ⁴	10.16.1
I_s	Moment of inertia of secondary members, mm ⁴	10.16.1
I_x, I_y	Moment of inertia about the principal axes, mm ⁴	10.5.4
I_y	Out-of-plane moment of inertia, mm ⁴	10.19.2
I_z	Minor principal axis moment of inertia, mm ⁴	10.6.10.2
I_{yc}	Moment of inertia about y-axis referred to the compression flange, or if reverse curvature bending referred to smaller flange, mm ⁴	10.6.1
J	Torsional constant, mm ⁴	10.5.4
K	Effective length factor determined in accordance with Sec 10.3	10.3.1.2
K	Effective length factor for prismatic member	10.20.13
K_z	Effective length factor for torsional buckling	10.5.4
K_1	Effective length factor in plane of bending, calculated based on the assumption of no lateral translation set equal to 1.0 unless analysis indicates a smaller value to be used.	10.3.2.1
K_2	Effective length factor in the plane of bending, calculated based on a sidesway buckling analysis	10.3.2.1
L	Story height, mm.	10.3.2.1
L	Laterally unbraced length of a member, mm.	10.5.2
L	Length of member between work points at truss chord centerlines, mm.	10.5.5

Symbol	Meaning	Section
L	Length of the member, mm.	10.8.3
L	Actual length of end-loaded weld, mm.	10.10.2.2
L	Nominal occupancy live load	10.18.1.4
L	Span length, mm.	10.19.2
L	Span length of the truss, mm.	10.20.12
L	Distance between VBE centerlines, mm	10.20.17
L_b	Distance between braces, mm.	10.19.2
L_b	Length between points that are either braced against lateral displacement of compression flange or braced against twist of the cross section, mm.	10.6.2, 10.20.13
L_c	Distance between plastic hinge locations, mm	10.20.9
L_c	Clear distance, in the direction of the force, between the edge of the hole and the edge of the adjacent hole or edge of the material,mm.	10.10.3.10
L_c	Link length, mm	10.20.15
L_{cf}	Clear distance between VBE flanges, mm	10.20.17
L_e	Total effective weld length of groove and fillet welds to rectangular HSS,mm.	10.11.2.3
L_p	Limiting laterally unbraced length for the limit state of yielding, mm.	10.6.2.2
L_p	Column spacing in direction of girder, m	10.16
L_p	Limiting laterally unbraced length for full plastic flexural strength, uniform moment case,mm.	10.20.12
L_{pd}	Limiting laterally unbraced length for plastic analysis, mm.	10.15.7
L_{pd}	Limiting laterally unbraced length for plastic analysis, mm	10.20.13
L_q	Maximum unbraced length for M_r (the required flexural strength),mm.	10.19.2
L_r	Limiting laterally unbraced length for limit state of inelastic lateral-torsional buckling, mm.	10.6.2.2

<u>Symbol</u>	<u>Meaning</u>	<u>Section</u>
L_s	Column spacing perpendicular to direction of girder, m	10.16.1
L_s	Length of the special segment, mm	10.20.12
L_v	Distance from maximum to zero shear force,mm.	10.7.6
M_A	Absolute value of moment at quarter point of the unbraced segment, N-mm.	10.6.1
M_a	Required flexural strength in chord, using ASD load combinations, N-mm.	10.11.2.2
M_a	Required flexural strength, using ASD load combinations, N-mm.	10.20.9
M_{av}	Additional moment due to shear amplification from the location of plastic hinge to the column centerline based on ASD load combinations, N-mm.	10.20.9
M_B	Absolute value of moment at centerline of the unbraced segment, N-mm.	10.6.1
M_{br}	Required bracing moment,N-mm.	10.19.2
M_C	Absolute value of moment at three-quarter point of unbraced segment, N-mm.	10.6.1
$M_{C(x,y)}$	Available flexural strength determined in accordance with Sec 10.6,N-mm.	10.8.1.1
M_{Cx}	Available flexural-torsional strength for strong axis flexure determined in accordance with Sec 10.6,N-mm.	10.8.1.3
M_e	Elastic lateral-torsional buckling moment, N-mm.	10.6.10.2
M_{lt}	First-order moment under LRFD or ASD load combinations caused by lateral translation of the frame only, N-mm.	10.3.2.1
M_{max}	Absolute value of maximum moment in the unbraced segment,N-mm.	10.6.1
M_n	Nominal flexural strength, N-mm.	10.6.1
M_n	Nominal flexural strength, N-mm.	10.20.11
M_{nc}	Nominal flexural strength of the chord member of special segment, N-mm.	10.20.12
M_{nt}	First-order moment using LRFD or ASD load combinations assuming there is no lateral translation of the frame, N-mm.	10.3.2.1

Symbol	Meaning	Section
M_p	Plastic bending moment, N-mm.	Table 6.10.1
M_p	Nominal plastic flexural strength, N-mm.	Table 6.10.8
M_{pa}	Nominal plastic flexural strength modified by axial load, N-mm.	10.20.15
M_{pb}	Nominal plastic flexural strength of the beam, N-mm.	10.20.9
M_{pc}	Nominal plastic flexural strength of the column, N-mm.	10.20.8
$M_{p,exp}$	Expected plastic moment, N-mm.	10.20.9
M_r	Required second-order flexural strength under LRFD or ASD load combinations, N-mm.	10.3.2.1
M_r	Required flexural strength using LRFD or ASD load combinations, N-mm.	10.8.1
M_r	Required flexural strength in chord, N-mm.	10.11.2.2
M_r	Expected flexural strength, N-mm.	10.20.9
M_{r-ip}	Required in-plane flexural strength in branch, N-mm.	10.11.3.2
M_{r-op}	Required out-of-plane flexural strength in branch, N-mm.	10.11.3.2
M_u	Required flexural strength, using LRFD load combinations, N-mm.	10.20.9
M_u	Required flexural strength in chord, using LRFD load combinations, N-mm.	10.11.2.2
M_{uv}	Additional moment due to shear amplification from the location of plastic hinge to the column centerline based on LRFD load combinations, N-mm.	10.20.9
$M_{u,exp}$	Expected required flexural strength, N-mm.	10.20.15
M_y	Yield moment about the axis of bending, N-mm.	Table 6.10.1
M_1	Smaller moment, calculated from a first-order analysis, at the ends of that portion of the member unbraced in the plane of bending under consideration, N-mm.	10.3.2.1
M_2	Larger moment, calculated from a first-order analysis, at the ends of that portion of the member unbraced in the plane of bending under consideration, N-mm.	10.3.2.1

<u>Symbol</u>	<u>Meaning</u>	<u>Section</u>
N	Length of bearing (not less than k for end beam reactions),mm.	10.10.10.2
N	Bearing length of the load, measured parallel to the axis of the HSS member, (or measured across the width of the HSS in the case of the loaded cap plates), mm.	10.11.1.1
N	Number of stress range fluctuations in design life	10.17.3
N_b	Number of bolts carrying the Applied tension	10.10.3.9
N_i	Additional lateral load	10.3.2.2
N_i	Notional lateral load Applied at level i , N.	10.14.3
N_s	Number of slip planes	10.10.3.8
O_v	Overlap connection coefficient	10.11.2.2
P	Pitch, mm per thread	10.17.4
P_a	Required axial strength of a column using ASD load combinations, N.	10.20.8
P_{ac}	Required compressive strength using ASD load combinations, N.	10.20.9
P_b	Required strength of lateral brace at ends of the link, N.	10.20.15
P_{br}	Required brace strength, N.	10.19.2
P_c	Available axial compressive strength, N.	10.8.1.1
P_c	Available tensile strength, N.	10.8.1.2
P_c	Available axial strength of a column, N.	10.20.9
P_{co}	Available compressive strength out of the plane of bending, N.	10.8.1.3
P_{e1}, P_{e2}	Elastic critical buckling load for braced and unbraced frame, respectively, N.	10.3.2.1
P_{eL}	Euler buckling load, evaluated in the plane of bending, N.	10.14.3

Symbol	Meaning	Section
$P_{l(t,c)}$	First-order axial force using LRFD or ASD load combinations as a result of lateral translation of the frame only (tension or compression, N).	10.3.2.1
$P_{n(t,c)}$	First-order axial force using LRFD or ASD load combinations, assuming there is no lateral translation of the frame (tension or compression, N).	10.3.2.1
P_n	Nominal axial strength, N.	10.4.2
P_n	Nominal axial strength of a column, N.	10.20.8
P_{nc}	Nominal axial compressive strength of diagonal members of the special segment, N.	10.20.12
P_{nt}	Nominal axial tensile strength of diagonal members of special segment, N.	10.20.12
P_{rc}	Required compressive strength using ASD or LRFD load combinations, N.	10.20.9
P_r	Required second-order axial strength using LRFD or ASD load combinations, N.	10.3.2.1
P_r	Required axial compressive strength using LRFD or ASD load combinations, N.	10.3.2.2
P_r	Required tensile strength using LRFD or ASD load combinations, N.	10.8.1.2
P_r	Required strength, N.	10.10.10.6
P_r	Required axial strength in chord, N.	10.11.2.2
P_r	Required axial strength in branch, N.	10.11.3.2
P_r	Required compressive strength, N.	10.20.15
P_u	Required axial strength in compression, N.	10.15.4
P_u	Required axial strength of a column or a link in LRFD load combinations, N.	10.20.8
P_{uc}	Required compressive strength using LRFD load combinations, N.	10.20.9
P_y	Member yield strength, N.	10.3.2.2
P_y	Nominal axial yield strength of a member, equal to $F_y A_g$, N.	Table 6.10.8

Symbol	Meaning	Section
$P_{y_{sc}}$	Axial yield strength of steel core, N.	10.20.16
Q	Full reduction factor for slender compression elements	10.5.7
Q_a	Reduction factor for slender stiffened compression elements	10.5.7.2
Q_b	Maximum unbalanced vertical load effect applied to a beam by the braces, N.	10.20.13
Q_1	Axial forces and moments generated by at least 1.25 times the expected nominal shear strength of the link	10.20.15
Q_f	Chord-stress interaction parameter	10.11.2.2
Q_s	Reduction factor for slender unstiffened compression elements	10.5.7.1
R	Seismic response modification coefficient	10.20.1
R	Seismic response modification coefficient	10.1.1.1
R	Nominal load due to rainwater or snow, exclusive of the ponding contribution, MPa.	10.16.2
R_a	Required strength (ASD)	10.2.3.4
R_{FIL}	Reduction factor for joints using a pair of transverse fillet welds only	10.17.3
R_m	Factor in Eq. 6.10.8 dependent on type of system	10.3.2.1
R_m	Cross-section monosymmetry parameter	10.6.1
R_n	Nominal strength, N.	10.2.3.3
R_n	Nominal strength, N.	10.20.6
R_n	Nominal slip resistance, N.	10.10.3.8
R_{pc}	Web plastification factor	10.6.4.1
R_{PJP}	Reduction factor for reinforced or unreinforced transverse partial-joint-penetration (PJP) groove welds	10.17.3
R_{pt}	Web plastification factor corresponding to the tension flange yielding limit state	10.6.4.4

Symbol	Meaning	Section
R_t	Ratio of the expected tensile strength to the specified minimum tensile strength F_u , as related to overstrength in material yield stress R_y	10.20.6
R_u	Required strength (LRFD)	10.2.3.3
R_u	Required strength	10.20.9
R_v	Panel zone nominal shear strength	10.20.9
R_{wl}	Total nominal strength of longitudinally loaded fillet welds, as determined in accordance with Table 6.10.8	10.10.2.4
R_{wt}	Total nominal strength of transversely loaded fillet welds, as determined in accordance with Table 6.10.8 without the alternate in Sec 10.10.2.4 (a)	10.10.2.4
R_y	Ratio of the expected yield stress to the specified minimum yield stress, F_y	10.20.6
S	Elastic section modulus of round HSS, mm^3	10.6.8.2
S	Lowest elastic section modulus relative to the axis of bending, mm^3	10.6.12
S	Chord elastic section modulus, mm^3	10.11.2.2
S	Spacing of secondary members, m	10.16.1
S_c	Elastic section modulus to toe in compression relative to axis of bending, mm^3 .	10.6.10.3
S_{eff}	Effective section modulus about major axis, mm^3	10.6.7.2
S_{xt}, S_{xc}	Elastic section modulus referred tension and compression flanges, respectively, mm^3	Table 6.10.1
S_x, S_y	Elastic section modulus taken about the principal axes, mm^3	10.6.2.2, F6
S_y	For channels, taken as the minimum section modulus	10.6.6
T	Nominal forces and deformations due to design-basis fire defined in Sec 4.2.1	10.18.1.4
T_a	Tension force due to ASD load combinations, kN.	10.10.3.9

<u>Symbol</u>	<u>Meaning</u>	<u>Section</u>
T_b	Minimum fastener tension given in Table 6.10.9, kN.	10.10.3.8
T_c	Available torsional strength, N-mm.	10.8.3.2
T_n	Nominal torsional strength, N-mm.	10.8.3.1
T_r	Required torsional strength, N-mm.	10.8.3.2
T_u	Tension force due to LRFD load combinations, kN.	10.10.3.9
U	Shear lag factor	10.4.3.3
U	Utilization ratio	10.11.2.2
U_{bs}	Reduction coefficient, used in calculating block shear rupture strength	10.10.4.3
U_p	Stress index	10.16.2
U_s	Stress index	10.16.2
V_a	Required shear strength using ASD load combinations, N.	10.20.9
V_c	Available shear strength, N.	10.7.3.3
V_n	Nominal shear strength, N.	10.7.1
V_n	Nominal shear strength of a member, N.	10.20.15
V_p	Nominal shear strength of an active link, N.	Table 6.10.8
V_{pa}	Nominal shear strength of an active link modified by axial load magnitude, N.	10.20.15
V_{ne}	Expected vertical shear strength of the special segment, N.	10.20.12
V_r	Required shear strength at the location of the stiffener, N.	10.7.3.3
V_r	Required shear strength using LRFD or ASD load combinations, N.	10.8.3.2
V_u	Required shear strength using LRFD load combinations, N.	10.20.10
Y_i	Gravity load from the LRFD load combination or 1.6 times the ASD load combination Applied at level i , N.	10.3.2.2
Y_t	Hole reduction coefficient, N.	10.6.13.1

Symbol	Meaning	Section
Z	Plastic section modulus about the axis of bending, mm^3	10.6.7.1
Z	Plastic section modulus of a member, mm^3 .	10.20.9
Z_b	Branch plastic section modulus about the correct axis of bending, mm^3	10.11.3.3
Z_b	Plastic section modulus of the beam, mm^3 .	10.20.9
Z_c	Plastic section modulus of the column, mm^3 .	10.20.9
Z_x	Plastic section modulus x -axis, mm^3 .	10.20.8
Z_{RBS}	Minimum plastic section modulus at the reduced beam section, mm^3 .	10.20.9
$Z_{x,y}$	Plastic section modulus about the principal axes, mm^3	10.6.2, F6.1
a	Shortest distance from edge of pin hole to edge of member measured parallel to direction of force, mm.	10.4.5.1
a	Distance between connectors in a built-up member, mm.	10.5.6.1
a	Clear distance between transverse stiffeners, mm.	10.6.13.2
a	Half the length of the non-welded root face in the direction of the thickness of the tension-loaded plate, mm.	10.17.3
a	Angle that diagonal members make with the horizontal	10.20.12
a_w	Ratio of two times the web area in compression due to Application of major axis bending moment alone to the area of the compression flange components	10.6.4.2
b	Width of unstiffened compression element; for flanges of I-shaped members and tees, the width b is half the full-flange width, b_f ; for legs of angles and flanges of channels and zees, the width b is the full nominal dimension; for plates, the width b is the distance from free edge to the first row of fasteners or line of welds, or the distance between adjacent lines of fasteners or lines of welds; for rectangular HSS, width b is the clear distance between the webs less the inside corner radius on each side, mm.	10.2.4.1, 10.2.4.2

Symbol	Meaning	Section
b	Full width of longest angle leg, mm.	10.5.7.1
b	Outside width of leg in compression, mm.	10.6.10.3
b	Width of the angle leg resisting the shear force, mm.	10.7.4
b	Width of compression element as defined in Specification Sec 10.2.4.1, mm.	Table 6.10.8
b_{cf}	Width of column flange, mm.	10.10.10.6
b_{cf}	Width of column flange, mm.	10.20.9
b_e	Reduced effective width, mm.	10.5.7.2
b_{eff}	Effective edge distance; the distance from the edge of the hole to the edge of the part measured in the direction normal to the applied force, mm.	10.4.5.1
b_{eoi}	Effective width of the branch face welded to the chord	10.11.2.3
b_{eov}	Effective width of the branch face welded to the overlapped brace.	10.11.2.3
b_f	Flange width, mm.	10.2.4.1
b_f	Flange width, mm.	10.20.9
b_{fc}	Compression flange width, mm.	10.6.4.2
b_{ft}	Width of tension flange, mm.	10.7.3.1
b_l	Longer leg of angle, mm.	10.5.5
b_s	Shorter leg of angle, mm.	10.5.5
b_s	Stiffener width for one-sided stiffeners, mm.	10.19.2
d	Full nominal depth of section, mm.	10.2.4.1
d	Pin diameter, mm.	10.4.5.1
d	Full nominal depth of tee, mm.	10.5.7.1
d	Depth of rectangular bar, mm.	10.6.11.2

Symbol	Meaning	Section
d	Nominal fastener diameter, mm.	10.10.3.3
d	Diameter, mm.	10.10.7
d	Roller diameter, mm.	10.10.7
d	Nominal fastener diameter, mm.	10.20.7
d	Overall beam depth, mm.	10.20.15
d_b	Beam depth, mm.	10.10.10.6
d_b	Nominal diameter (body or shank diameter), mm.	10.17.4
d_c	Column depth, mm.	10.10.10.6
d_c	Overall column depth, mm.	10.20.9
d_z	Overall panel zone depth between continuity plates, mm.	10.20.9
e	Eccentricity in a truss connection, positive being away from the branches, mm.	10.11.2.1
e	EBF link length, mm.	10.20.15
f_a	Required axial stress at point of consideration of LRFD or ASD load combinations, MPa.	10.8.2
$f_{b(w,z)}$	Required flexural stress at the point of consideration (major axis, minor axis) using LRFD or ASD load combinations, MPa.	10.8.2
f'_{cm}	Specified minimum compressive strength of concrete at elevated temperatures, MPa.	10.18.2
f_o	Stress due to D + R (the nominal dead load + the nominal load due to rainwater or snow exclusive of the ponding contribution, MPa.	10.16.2
f_v	Required shear strength per unit area, MPa.	10.10.3.7
g	Transverse center-to-center spacing (gage) between fastener gage lines, mm.	10.2.3.13
g	Gap between toes of branch members in a gapped K-connection, neglecting welds, mm.	10.11.2.1
h	Clear distance between flanges less the fillet or corner radius for rolled shapes; for built-up sections, the distance between adjacent lines of fasteners or the clear distance between flanges when welds are used; for tees, the overall depth; for rectangular HSS, the clear distance between the flanges less the inside corner radius on each side, mm.	10.2.4.2, Table 6.10.8

Symbol	Meaning	Section
h	Distance between centroids of individual components perpendicular to the member axis of buckling,mm.	10.5.6.1
h	Distance between horizontal boundary element centerlines, mm.	10.20.17
h_c	Twice the distance from the centroid to the following: the inside face of the compression flange less the fillet or corner radius, for rolled shapes; the nearest line of fasteners at the compression flange or the inside faces of the compression flange when welds are used, for built-up sections, mm.	10.2.4.2
h_o	Distance between flange centroids, mm.	10.6.2.2
h_o	Distance between flange centroids, mm	10.20.9
h_p	Twice the distance from plastic neutral axis to the nearest line of fasteners at the compression flange or inside face of compression flange when welds are used, mm	10.2.4.2
h_{sc}	Hole factor	10.10.3.8
j	Factor defined by Eq. 6.10.141 for minimum moment of inertia for a transverse stiffener	10.7.2.2
k	Distance from outer face of flange to the web toe of fillet, mm.	10.10.10.2
k	Outside corner radius of HSS, which is permitted to be taken as $1.5t$ if unknown, mm.	10.11.1.3
k_c	Coefficient for slender unstiffened elements, mm.	Table 6.10.1
k_s	Slip-critical combined tension and shear coefficient	10.10.3.9
k_v	Web plate buckling coefficient	10.7.2.1
l	Largest laterally unbraced length along either flange at the point of load, mm.	10.10.10.4
l	Length of bearing,mm.	10.10.7
l	Length of connection in the direction of loading,mm.	Table 6.10.2
l	Unbraced length between stitches of built-up bracing members,mm.	10.20.13
l	Unbraced length of compression or bracing member, mm.	10.20.13

Symbol	Meaning	Section
n	Number of nodal braced points within the span	10.19.2
n	Threads per mm.	10.17.4
p	Ratio of element i deformation to its deformation at maximum stress	10.10.2.4
p	Projected length of the overlapping branch on the chord	10.11.2.2
q	Overlap length measured along the connecting face of the chord beneath the two branches	10.11.2.2
r	Governing radius of gyration, mm.	10.5.2
r	Governing radius of gyration, mm.	10.20.13
r_{crit}	Distance from instantaneous center of rotation to weld element with minimum $\frac{\Delta u}{r_i}$ ratio, mm.	10.10.2.4
r_i	Minimum radius of gyration of individual component in a built-up member, mm.	10.5.6.1
r_{ib}	Radius of gyration of individual component relative to its centroidal axis parallel to member axis of buckling, mm.	10.5.6.1
\bar{r}_o	Polar radius of gyration about the shear center, mm.	10.5.4
r_t	Radius of gyration of the flange components in flexural compression plus one-third of the web area in compression due to application of major axis bending moment alone	10.6.4.2
r_{ts}	Effective radius of gyration used in the determination of L_r for the lateral-torsional buckling limit state for major axis bending of doubly symmetric compact I-shaped members and channels	10.6.2.2
r_x	Radius of gyration about geometric axis parallel to connected leg, mm.	10.5.5
r_y	Radius of gyration about y-axis, mm.	10.5.4
r_y	Radius of gyration about y-axis, mm.	10.20.9
r_z	Radius of gyration for the minor principal axis, mm.	10.5.5

<u>Symbol</u>	<u>Meaning</u>	<u>Section</u>
s	Longitudinal center-to-center spacing (pitch) of any two consecutive holes, mm.	10.2.3.13
t	Thickness of element, mm.	10.2.4.2
t	Thickness of element, mm.	Table 6.10.8
t	Wall thickness, mm.	10.5.7.2
t	Angle leg thickness, mm.	10.6.10.2
t	Width of rectangular bar parallel to axis of bending, mm.	10.6.11.2
t	Thickness of connected material, mm.	10.10.3.10
t	Thickness of plate, mm.	10.4.5.1
t	Design wall thickness for HSS equal to 0.93 times the nominal wall thickness for ERW HSS and equal to the nominal wall thickness for SAW HSS, mm.	10.2.3.12
t	Total thickness of fillers, mm.	10.10.5
t	Thickness of connected part, mm.	10.20.7
t	Thickness of column web or doubler plate, mm.	10.20.9
t	Design wall thickness of HSS main member, mm.	10.11.3.1
t	Design wall thickness of HSS main member, mm.	10.11.2.1
t	Design wall thickness of HSS member, mm.	10.11.1.1
t_b	Design wall thickness of HSS branch member, mm.	10.11.2.1
t_b	Design wall thickness of HSS branch member, mm.	10.11.3.1
t_{bf}	Thickness of beam flange, mm.	10.20.9
t_{bj}	Thickness of the overlapped branch, mm.	10.11.2.3
t_{cf}	Thickness of the column flange, mm.	10.10.10.6

Symbol	Meaning	Section
t_{cf}	Thickness of column flange, mm.	10.20.9
t_f	Thickness of the loaded flange, mm.	10.10.10.1
t_f	Thickness of flange, mm.	10.20.17
t_{fc}	Compression flange thickness, mm.	10.6.4.2
t_p	Thickness of plate, mm.	10.11.1.1
t_p	Thickness of the attached transverse plate, mm.	10.11.2.3
t_p	Thickness of tension loaded plate, mm.	10.17.3
t_p	Thickness of panel zone including doubler plates, mm.	10.20.9
t_s	Web stiffener thickness, mm.	10.19.2
t_w	Web thickness, mm.	Table 6.10.1
t_w	Thickness of web, mm.	Table 6.10.8
t_w	Thickness of element, mm.	10.5.7.1
t_w	Column web thickness, mm.	10.10.10.6
t_w	Beam web thickness, mm.	10.19.3
w	Width of cover plate, mm.	10.6.13.3
w	Weld leg size, mm.	10.10.2.2
w	Plate width, mm.	Table 6.10.2
w	Leg size of the reinforcing or contouring fillet, if any, in the direction of the thickness of the tension-loaded plate, mm.	10.17.3
w_z	Width of panel zone between column flanges, mm.	10.20.9
x	Parameter used for determining the approximate fundamental period	Appendix P.2
x_o, y_o	Coordinates of the shear center with respect to the centroid, mm.	10.5.4

Symbol	Meaning	Section
\bar{x}	Connection eccentricity,mm.	Table 6.10.2
y	Subscript relating symbol to weak axis	
z	Subscript relating symbol to minor principal axis bending	
Z_b	Minimum plastic section modulus at the reduced beam section, mm ³	10.20.9
α	Factor used in Eq. 6.10.2.2	10.3.2.1
α	Separation ratio for built-up compression members $=h/(2r_{ib})$	10.5.6.1
α	Angle of diagonal members with the horizontal	10.20.12
α	Angle of web yielding in radians, as measured relative to the vertical	10.20.17
β	Reduction factor given by Eq. 6.10.159	10.10.2.2
β	The width ratio; the ratio of branch diameter to chord diameter $= D_b/D$ for round HSS; the ratio of overall branch width to chord width $= B_b/B$ for rectangular HSS	10.11.2.1, 10.11.3.1
β	Compression strength adjustment factor	10.20.16
β_T	Brace stiffness requirement excluding web distortion, N-mm/radian.	10.19.2
β_{br}	Required brace stiffness	10.19.2
β_{eff}	Effective width ratio; the sum of the perimeters of the two branch members in a K-connection divided by eight times the chord width	10.11.2.1
β_{eop}	Effective outside punching parameter	10.11.2.3
β_{sec}	Web distortional stiffness, including the effect of web transverse stiffeners, if any, N-mm/radian.	10.19.2
β_w	Section property for unequal leg angles, positive for short legs in compression and negative for long legs in compression	10.6.10.2
Δ	First-order interstory drift due to the design loads,mm.	10.3.2.2

Symbol	Meaning	Section
Δ	Design story drift	10.20.15
Δ_b	Deformation quantity used to control loading of test specimen (total brace end rotation for the sub-assembly test specimen; total brace axial deformation for the brace test specimen)	Appendix R.2
Δ_{bm}	Value of deformation quantity, Δ_b , corresponding to the design story drift	Appendix R.6
Δ_{by}	Value of deformation quantity, Δ_b , at first significant yield of test specimen	Appendix R.6
Δ_h	First-order interstory drift due to lateral forces, mm.	10.3.2.1
Δ_i	Deformation of weld elements at intermediate stress levels, linearly proportioned to the critical deformation based on distance from instantaneous center of rotation, r_i , mm.	10.10.2.4
Δ_m	Deformation of weld element at maximum stress, mm.	10.10.2.4
Δ_u	Deformation of weld element at ultimate stress (fracture), usually in element furthest from instantaneous center of rotation, mm.	10.10.2.4
δ	Deformation quantity used to control loading of test specimen	Appendix Q.6
δ_y	Value of deformation quantity δ at first significant yield of test specimen	Appendix Q.6
ρ'	Ratio of required axial force P_u to required shear strength V_u of a link	10.20.15
γ	The chord slenderness ratio; the ratio of one-half the diameter to the wall thickness = $D/(2t)$ for round HSS; the ratio of one-half the width to wall thickness = $B/(2t)$ for rectangular HSS	10.11.2.1, 10.11.3.1
ξ	The gap ratio; the ratio of the gap between the branches of a gapped K-connection to the width of the chord = g/B for rectangular HSS	10.11.2.1

Symbol	Meaning	Section
η	The load length parameter, applicable only to rectangular HSS; the ratio of the length of contact of the branch with the chord in the plane of the connection to the chord width = N/B , where $N = H_b/\sin \theta$	10.11.2.1, 10.11.3.1
λ	Slenderness parameter	10.6.3
λ_p	Limiting slenderness parameter for compact element	10.2.4
λ_{pf}	Limiting slenderness parameter for compact flange	10.6.3
λ_{pw}	Limiting slenderness parameter for compact web	10.6.4
λ_r	Limiting slenderness parameter for noncompact element	10.2.4
λ_{rf}	Limiting slenderness parameter for noncompact flange	10.6.3
λ_{rw}	Limiting slenderness parameter for noncompact web	10.6.4
λ_p, λ_{ps}	Limiting slenderness parameter for compact element	10.20.8
μ	Mean slip coefficient for class A or B surfaces, as Applicable, or as established by tests	10.10.3.8
ϕ	Resistance factor	10.2.3.3
ϕ	Resistance factor	10.20.6
ϕ_b	Resistance factor for flexure	10.6.1
ϕ_b	Resistance factor for flexure	10.20.8
ϕ_c	Resistance factor for compression	10.5.1
ϕ_c	Resistance factor for compression	10.20.8
ϕ_{sf}	Resistance factor for shear on the failure path	10.4.5.1
ϕ_T	Resistance factor for torsion	10.8.3.1
ϕ_t	Resistance factor for tension	10.4.2
ϕ_v	Resistance factor for shear	10.7.1

<u>Symbol</u>	<u>Meaning</u>	<u>Section</u>
ϕ_v	Resistance factor for shear strength of panel zone of beam-to-column connections	10.20.9
ϕ_v	Resistance factor for shear	10.20.15
ϕ_{total}	Link rotation angle	Appendix Q.2
Ω	Safety factor	10.2.3.4
Ω	Safety factor	10.20.6
Ω_b	Safety factor for flexure	10.6.1
Ω_b	Safety factor for flexure = 1.67	10.20.8
Ω_c	Safety factor for compression	10.5.1
Ω_c	Safety factor for compression = 1.67	10.20.8
Ω_{sf}	Safety factor for shear on the failure path	10.4.5.1
Ω_T	Safety factor for torsion	10.8.3.1
Ω_t	Safety factor for tension	10.4.2
Ω_v	Safety factor for shear	10.7.1
Ω_v	Safety factor for shear strength of panel zone of beam-to-column connections	10.20.9
Ω_o	Horizontal seismic overstrength factor	10.20.4
θ	Angle of loading measured from the weld longitudinal axis, degrees	10.10.2.4
θ	Acute angle between the branch and chord, degrees	10.11.2.1
θ	Acute angle between the branch and chord, degrees	10.11.3.1
θ	Interstory drift angle, radians	Appendix Q.3
ω	Strain hardening adjustment factor	10.20.16
ϵ_{cu}	Strain corresponding to compressive strength of concrete, f'_c	10.18.2
τ_b	Parameter for reduced flexural stiffness using the direct analysis method	10.14.3

Symbol	Meaning	Section
ΣM^*_{pc}	Moment at beam and column centerline determined by projecting the sum of the nominal column plastic moment strength, reduced by the axial stress P_{uc}/A_g , from the top and bottom of the beam moment connection	10.20.9
ΣM^*_{pb}	Moment at the intersection of the beam and column centerlines determined by projecting the beam maximum developed moments from the column face. Maximum developed moments shall be determined from test results	10.20.9

10.1.2.2 Definitions

ACTIVE FIRE PROTECTION	Building materials and systems that are activated by a fire to mitigate adverse effects or to notify people to take some action to mitigate adverse effects.
ADJUSTED BRACE STRENGTH	Strength of a brace in a buckling-restrained braced frame at deformations corresponding to 2.0 times the design story drift.
ALLOWABLE STRENGTH*	Nominal strength divided by the safety factor, R_n/Ω .
ALLOWABLE STRESS	Allowable strength divided by the appropriate section property, such as section modulus or cross-section area.
AMPLIFICATION FACTOR	Multiplier of the results of first-order analysis to reflect second-order effects.
AMPLIFIED SEISMIC LOAD	Horizontal component of earthquake load E multiplied by Ω_o , where E and the horizontal component of E are specified in the Code.
APPLICABLE BUILDING CODE	Building Code under which the structure is designed.
ASD(ALLOWABLE STRENGTH DESIGN)	Method of proportioning structural components such that the allowable strength equals or exceeds the required strength of the component under the action of the ASD load combinations.
ASD LOAD COMBINATION	Load combination in the Code intended for allowable strength design (allowable stress design).

AUTHORITY HAVING JURISDICTION	Organization, political subdivision, office or individual charged with the responsibility of administering and enforcing the provisions of the Code.
AVAILABLE STRENGTH*	Design strength or allowable strength, as appropriate.
AVAILABLE STRESS*	Design stress or allowable stress, as appropriate.
AVERAGE RIB WIDTH	Average width of the rib of a corrugation in a formed steel deck.
AUTHORITY HAVING JURISDICTION (AHJ)	Organization, political subdivision, office or individual charged with the responsibility of administering and enforcing the provisions of this Code.
BATTEN PLATE	Plate rigidly connected to two parallel components of a built-up column or beam designed to transmit shear between the components.
BEAM	Structural member that has the primary function of resisting bending moments. Beam-column. Structural member that resists both axial force and bending moment. Bearing. In a bolted connection, limit state of shear forces transmitted by the bolt to the connection elements.
BEARING (LOCAL COMPRESSIVE YIELDING)	Limit state of local compressive yielding due to the action of a member bearing against another member or surface.
BEARING-TYPE CONNECTION	Bolted connection where shear forces are transmitted by the bolt bearing against the connection elements.
BLOCK SHEAR RUPTURE	In a connection, limit state of tension fracture along one path and shear yielding or shear fracture along another path.
BRACED FRAME	An essentially vertical truss system that provides resistance to lateral forces and provides stability for the structural system.
BRANCH FACE	Wall of HSS branch member.
BRANCH MEMBER	For HSS connections, member that terminates at a chord member or main member.
BUCKLING	Limit state of sudden change in the geometry of a structure or any of its elements under a critical loading condition.

BUCKLING STRENGTH	Nominal strength for buckling or instability limit states.
BUCKLING-RESTRAINED BRACED FRAME (BRBF)	Diagonally braced frame satisfying the requirements of Section 16 in which all members of the bracing system are subjected primarily to axial forces and in which the limit state of compression buckling of braces is precluded at forces and deformations corresponding to 2.0 times the design story drift.
BUCKLING-RESTRAINING SYSTEM	System of restraints that limits buckling of the steel core in BRBF. This system includes the casing on the steel core and structural elements adjoining its connections. The buckling-restraining system is intended to permit the transverse expansion and longitudinal contraction of the steel core for deformations corresponding to 2.0 times the design story drift.
BUILT-UP MEMBER, CROSS-SECTION, SECTION, SHAPE	Member, cross-section, section or shape fabricated from structural steel elements that are welded or bolted together.
CAMBER	Curvature fabricated into a beam or truss so as to compensate for deflection induced by loads.
CASING	Element that resists forces transverse to the axis of the brace there by restraining buckling of the core. The casing requires a means of delivering this force to the remainder of the buckling-restraining system. The casing resists little or no force in the axis of the brace.
CHARPY V-NOTCH IMPACT TEST	Standard dynamic test measuring notch toughness of a specimen.
CHORD MEMBER	For HSS, primary member that extends through a truss connection.
CLADDING	Exterior covering of structure.
COLD-FORMED STEEL STRUCTURAL MEMBER	Shape manufactured by press-braking blanks sheared from sheets, cut lengths of coils or plates, or by roll forming cold- or hot-rolled coils or sheets; both forming operations being performed at ambient room temperature, that is, without manifest addition of heat such as would be required for hot forming.
COLUMN	Structural member that has the primary function of resisting axial force.

COLUMN BASE	Assemblage of plates, connectors, bolts, and rods at the base of a column used to transmit forces between the steel superstructure and the foundation.
COMBINED SYSTEM	Structure comprised of two or more lateral load-resisting systems of different type.
COMPACT SECTION	Section capable of developing a fully plastic stress distribution and possessing a rotation capacity of approximately three before the onset of local buckling.
COMPARTMENTATION	The enclosure of a building space with elements that have a specific fire endurance.
COMPLETE-JOINT-PENETRATION GROOVE WELD (CJP)	Groove weld in which weld metal extends through the joint thickness, except as permitted for HSS connections.
COMPOSITE	Condition in which steel and concrete elements and members work as a unit in the distribution of internal forces.
CONCRETE CRUSHING	Limit state of compressive failure in concrete having reached the ultimate strain.
CONCRETE HAUNCH	Section of solid concrete that results from stopping the deck on each side of the girder in a composite floor system constructed using a formed steel deck.
CONCRETE-ENCASED BEAM	Beam totally encased in concrete cast integrally with the slab.
CONNECTION	Combination of structural elements and joints used to transmit forces between two or more members.
CONVECTIVE HEAT TRANSFER	The transfer of thermal energy from a point of higher temperature to a point of lower temperature through the motion of an intervening medium.
CONTINUITY PLATES	Column stiffeners at the top and bottom of the panel zone; also known as transverse stiffeners.
CONTRACTOR	Fabricator or erector, as applicable.
COPE	Cutout made in a structural member to remove a flange and conform to the shape of an intersecting member.
COVER PLATE	Plate welded or bolted to the flange of a member to increase cross-sectional area, section modulus or moment of inertia.

CROSS CONNECTION	HSS connection in which forces in branch members or connecting elements transverse to the main member are primarily equilibrated by forces in other branch members or connecting elements on the opposite side of the main member.
DEMANDCRITICAL WELD	Weld so designated by these Provisions.
DESIGNEARTHQUAKE	The earthquake represented by the design response spectrum as specified in the Code.
DESIGNSTORYDRIFT	Amplified story drift (drift under the design earthquake, including the effects of inelastic action), determined as specified in the Code.
DESIGN-BASIS FIRE	A set of conditions that define the development of a fire and the spread of combustion products throughout a building or portion thereof.
DESIGN LOAD*	Applied load determined in accordance with either LRFD load combinations or ASD load combinations, whichever is applicable.
DESIGN STRENGTH*	Resistance factor multiplied by the nominal strength, ϕR_n .
DESIGN STRESS RANGE	Magnitude of change in stress due to the repeated application and removal of service live loads. For locations subject to stress reversal it is the algebraic difference of the peak stresses.
DESIGN STRESS*	Design strength divided by the appropriate section property, such as section modulus or cross section area.
DESIGN WALL THICKNESS	HSS wall thickness assumed in the determination of section properties.
DIAGONAL BRACING	Inclined structural member carrying primarily axial force in a braced frame.
DIAGONAL STIFFENER	Web stiffener at column panel zone oriented diagonally to the flanges, on one or both sides of the web.
DIAPHRAGM PLATE	Plate possessing in-plane shear stiffness and strength, used to transfer forces to the supporting elements.
DIAPHRAGM	Roof, floor or other membrane or bracing system that transfers in-plane forces to the lateral force resisting system.

DIRECT ANALYSIS METHOD	Design method for stability that captures the effects of residual stresses and initial out-of-plumbness of frames by reducing stiffness and applying notional loads in a second-order analysis.
DIRECT BOND INTERACTION	Mechanism by which force is transferred between steel and concrete in a composite section by bond stress.
DISTORTIONAL FAILURE	Limit state of an HSS truss connection based on distortion of a rectangular HSS chord member into a rhomboidal shape.
DISTORTIONAL STIFFNESS	Out-of-plane flexural stiffness of web.
DOUBLE CURVATURE	Deformed shape of a beam with one or more inflection points within the span.
DOUBLE-CONCENTRATED FORCES	Two equal and opposite forces that form a couple on the same side of the loaded member.
DOUBLER	Plate added to, and parallel with, a beam or column web to increase resistance to concentrated forces.
DRIFT	Lateral deflection of structure.
DUAL SYSTEM	Structural system with the following features (1) an essentially complete space frame that provides support for gravity loads; (2) resistance to lateral load provided by moment frames (SMF, IMF or OMF) that are capable of resisting at least 25 percent of the base shear, and concrete or steel shearwalls, or steel braced frames (EBF, S CBF or OCBF); and (3) each system designed to resist the total lateral load in proportion to its relative rigidity.
DUCTILE LIMIT STATE	Ductile limit states include member and connection yielding, bearing deformation at bolt holes, as well as buckling of members that conform to the width-thickness limitations of Table 6.10.18. Fracture of a member or of a connection, or buckling of a connection element, is not a ductile limit state.
ECCENTRICALLY BRACED FRAME (EBF)	Diagonally braced frame meeting there quirements of Section 15 that has at least one end of each bracing member connected to a beam a short distance from another beam-to-brace connection or a beam-to-column connection.
EFFECTIVE LENGTH FACTOR, K	Ratio between the effective length and the unbraced length of the member.

EFFECTIVE LENGTH	Length of an otherwise identical column with the same strength when analyzed with pinned end conditions.
EFFECTIVE NET AREA	Net area modified to account for the effect of shear lag.
EFFECTIVE SECTION MODULUS	Section modulus reduced to account for buckling of slender compression elements.
EFFECTIVE WIDTH	Reduced width of a plate or slab with an assumed uniform stress distribution which produces the same effect on the behavior of a structural member as the actual plate or slab width with its nonuniform stress distribution.
ELASTIC ANALYSIS	Structural analysis based on the assumption that the structure returns to its original geometry on removal of the load.
ELEVATED TEMPERATURES	Heating conditions experienced by building elements or structures as a result of fire, which are in excess of the anticipated ambient conditions.
ENCASED COMPOSITE COLUMN	Composite column consisting of a structural concrete column and one or more embedded steel shapes.
END PANEL	Web panel with an adjacent panel on one side only.
ENGINEER OF RECORD	Engineer having authority or license from government approved Authority to sign and seal engineering and contract documents.
END RETURN	Length of fillet weld that continues around a corner in the same plane. Engineer of record. Licensed professional responsible for sealing the contract documents. Expansion rocker. Support with curved surface on which a member bears that can tilt to accommodate expansion.
EXPANSION ROLLER	Round steel bar on which a member bears that can roll to accommodate expansion.
EXEMPTED COLUMN	Column not meeting the requirements of Eq. 6.10.300 for SMF.
EXPECTED TENSILE STRENGTH *	Tensile strength of a member, equal to the specified minimum tensile strength, F_u , multiplied by R_t .

EXPECTED YIELD STRENGTH	Yield strength in tension of a member, equal to the expected yield stress multiplied by A_g .
EXPECTED YIELD STRESS	Yield stress of the material, equal to the specified minimum yield stress, F_y , multiplied by R_y .
EYEBAR	Pin-connected tension member of uniform thickness, with forged or thermally cut head of greater width than the body, proportioned to provide approximately equal strength in the head and body.
FACTORED LOAD	Product of a load factor and the nominal load. Fastener. Generic term for bolts, rivets, or other connecting devices.
FATIGUE	Limit state of crack initiation and growth resulting from repeated application of live loads.
FAYING SURFACE	Contact surface of connection elements transmitting a shear force.
FILLED COMPOSITE COLUMN	Composite column consisting of a shell of HSS or pipe filled with structural concrete.
FILLER METAL	Metal or alloy to be added in making a welded joint. Filler. Plate used to build up the thickness of one component. Fillet weld reinforcement. Fillet welds added to groove welds.
FILLET WELD	Weld of generally triangular cross section made between intersecting surfaces of elements.
FIRE	Destructive burning, as manifested by any or all of the following: light, flame, heat, or smoke.
FIRE BARRIER	Element of construction formed of fire-resisting materials and tested in accordance with ASTM Standard E119, or other approved standard fire resistance test, to demonstrate compliance with the Building Code.
FIRE ENDURANCE	A measure of the elapsed time during which a material or assembly continues to exhibit fire resistance.
FIRE RESISTANCE	That property of assemblies that prevents or retards the passage of excessive heat, hot gases or flames under conditions of use and enables them to continue to perform a stipulated function.

FIRE RESISTANCE RATING	The period of time a building element, component or assembly maintains the ability to contain a fire, continues to perform a given structural function, or both, as determined by test or methods based on tests.
FIRST-ORDER ANALYSIS	Structural analysis in which equilibrium conditions are formulated on the undeformed structure; second-order effects are neglected.
FITTED BEARING STIFFENER	Stiffener used at a support or concentrated load that fits tightly against one or both flanges of a beam so as to transmit load through bearing.
FLASHOVER	The rapid transition to a state of total surface involvement in a fire of combustible materials within an enclosure.
FLARE BEVEL GROOVE WELD	Weld in a groove formed by a member with a curved surface in contact with a planar member.
FLARE V-GROOVE WELD	Weld in a groove formed by two members with curved surfaces.
FLAT WIDTH	Nominal width of rectangular HSS minus twice the outside corner radius. In absence of knowledge of the corner radius, the flat width may be taken as the total section width minus three times the thickness.
FLEXURAL BUCKLING	Buckling mode in which a compression member deflects laterally without twist or change in cross-sectional shape.
FLEXURAL-TORSIONAL BUCKLING	Buckling mode in which a compression member bends and twists simultaneously without change in cross-sectional shape.
FORCE	Resultant of distribution of stress over a prescribed area.
FORMED SECTION	See cold-formed steel structural member.
FORMED STEEL DECK	In composite construction, steel cold formed into a decking profile used as a permanent concrete form.
FULLY RESTRAINED MOMENT CONNECTION	Connection capable of transferring moment with negligible rotation between connected members.
GAGE	Transverse center-to-center spacing of fasteners.
GAP CONNECTION	HSS truss connection with a gap or space on the chord face between intersecting branch members.

GENERAL COLLAPSE	Limit state of chord plastification of opposing sides of a round HSSchord member at a cross-connection.
GEOMETRIC AXIS	Axis parallel to web, flange or angle leg.
GIRDER FILLER	Narrow piece of sheet steel used as a fill between edge of a deck sheet and flange of a girder in a composite floor system constructed using a formed steel deck.
GIRDER	See Beam.
GIRT	Horizontal structural member that supports wall panels and is primarily subjected to bending under horizontal loads, such as wind load.
GOUGE	Relatively smooth surface groove or cavity resulting from plastic deformation or removal of material.
GRAVITY AXIS	Axis through the center of gravity of a member along its length.
GRAVITY FRAME	Portion of the framing system not included in the lateral load resisting system.
GRAVITY LOAD	Load, such as that produced by dead and live loads, acting in the downward direction.
GRIP (OF BOLT)	Thickness of material through which a bolt passes.
GROOVE WELD	Weld in a groove between connection elements. See also AWS D1.1.
GUSSET PLATE	Plate element connecting truss members or a strut or brace to a beam or column.
HEAT FLUX	Radiant energy per unit surface area.
HEAT RELEASE RATE	The rate at which thermal energy is generated by a burning material.
HORIZONTAL SHEAR	Force at the interface between steel and concrete surfaces in a composite beam.
HSS	Square, rectangular or round hollow structural steel section produced in accordance with a pipe or tubing product specification.
INELASTIC ANALYSIS	Structural analysis that takes into account inelastic material behavior, including plastic analysis.

IN-PLANE INSTABILITY	Limit state of a beam-column bent about its major axis while lateral buckling or lateral-torsional buckling is prevented by lateral bracing.
INSTABILITY	Limit state reached in the loading of a structural component, frame or structure in which a slight disturbance in the loads or geometry produces large displacements.
INTERMEDIATE MOMENT FRAME (IMF)	Moment frame system that meets the requirements of Sec 10.20.10.
INTERSTORY DRIFT ANGLE	Interstory displacement divided by story height, radians.
INVERTED-V-BRACED FRAME	See V-braced frame.
JOINT ECCENTRICITY	For HSS truss connection, perpendicular distance from chord member center of gravity to intersection of branch member work points.
JOINT	Area where two or more ends, surfaces, or edges are attached. Categorized by type of fastener or weld used and method of force transfer.
K-AREA	The <i>k-area</i> is the region of the web that extends from the tangent point of the web and the flange-web fillet (AISC “ <i>k</i> ” dimension) a distance of 38 mm in to the web beyond the “ <i>k</i> ” dimension.
K-BRACED FRAME	A bracing configuration in which braces connect to a column at a location with no diaphragm or other out-of-plane support.
K-CONNECTION	HSS connection in which forces in branch members or connecting elements transverse to the main member are primarily equilibrated by forces in other branch members or connecting elements on the same side of the main member.
KSI	Kip per square inch, a US customary unit of stress.
LOWEST ANTICIPATED SERVICE TEMPERATURE (LAST)	The lowest 1-hour average temperature with a 100-year mean recurrence interval.
LRFD (LOAD AND RESISTANCE FACTOR DESIGN)	Method of proportioning structural components such that the design strength equals or exceeds the required strength of the component under the action of the LRFD load combinations.

LRFD LOAD COMBINATION	Load combination in the Code intended for strength design (load and resistance factor design).
LACING	Plate, angle or other steel shape, in a lattice configuration, that connects two steel shapes together.
LAP JOINT	Joint between two overlapping connection elements in parallel planes.
LATERAL BRACING	Diagonal bracing, shear walls or equivalent means for providing in-plane lateral stability.
LATERAL BRACING MEMBER	Member that is designed to inhibit lateral buckling or lateral-torsional buckling of primary framing members.
LATERAL LOAD RESISTING SYSTEM	Structural system designed to resist lateral loads and provide stability for the structure as a whole.
LATERAL LOAD	Load that produced by wind or earthquake effects, acting in a lateral direction.
LATERAL-TORSIONAL BUCKLING	Buckling mode of a flexural member involving deflection normal to the plane of bending occurring simultaneously with twist about shear center of the cross-section.
LEANING COLUMN	Column designed to carry gravity loads only, with connections that are not intended to provide resistance to lateral loads.
LENGTH EFFECTS	Consideration of the reduction in strength of a member based on its unbraced length.
LIMIT STATE	Condition in which a structure or component becomes unfit for service and is judged either to be no longer useful for its intended function (serviceability limit state) or to have reached its ultimate load-carrying capacity (strength limit state).
LINK	In EBF, the segment of a beam that is located between the ends of two diagonal braces or between the end of a diagonal brace and a column. The length of the link is defined as the clear distance between the end soft wodiagonal braces or between the diagonal brace and the column face.
LINK INTERMEDIATE WEB STIFFENERS	Vertical web stiffeners placed within the link in EBF.

LINK ROTATION ANGLE	Inelastic angle between the link and the beam outside of the link when the total story drift is equal to the design story drift.
LINK SHEAR DESIGN STRENGTH	Lesser of the available shear strength of the link developed from the moment or shear strength of the link.
LOAD	Force or other action that results from the weight of building materials, occupants and their possessions, environmental effects, differential movement, or restrained dimensional changes.
LOAD EFFECT	Forces, stresses and deformations produced in a structural component by the applied loads.
LOAD FACTOR	Factor that accounts for deviations of the nominal load from the actual load, for uncertainties in the analysis that transforms the load into a load effect and for the probability that more than one extreme load will occur simultaneously.
LOCAL BENDING**	Limit state of large deformation of a flange under a concentrated tensile force.
LOCAL BUCKLING**	Limit state of buckling of a compression element within a cross section.
LOCAL CRIPPLING**	Limit state of local failure of web plate in the immediate vicinity of a concentrated load or reaction.
LOCAL YIELDING**	Yielding that occurs in a local area of an element.
LRFD (LOAD AND RESISTANCE FACTOR DESIGN)	Method of proportioning structural components such that the design strength equals or exceeds the required strength of the component under the action of the LRFD load combinations.
LRFD LOAD COMBINATION	Load combination in the Code intended for strength design (load and resistance factor design).
MAIN MEMBER	For HSS connections, chord member, column or other HSS member to which branch members or other connecting elements are attached.
MEASURED FLEXURAL RESISTANCE	Bending moment measured in a beam at the face of the column, for a beam-to-column test specimen tested in accordance with Appendix S.
MECHANISM	Structural system that includes a sufficient number of real hinges, plastic hinges or both, so as to be able to articulate in one or more rigid body modes.

MILL SCALE	Oxide surface coating on steel formed by the hot rolling process.
MILLED SURFACE	Surface that has been machined flat by a mechanically guided tool to a flat, smooth condition.
MOMENT CONNECTION	Connection that transmits bending moment between connected members.
MOMENT FRAME	Framing system that provides resistance to lateral loads and provides stability to the structural system, primarily by shear and flexure of the framing members and their connections.
NET AREA	Gross area reduced to account for removed material.
NODAL BRACE	Brace that prevents lateral movement or twist independently of other braces at adjacent brace points (see relative brace).
NOMINAL DIMENSION	Designated or theoretical dimension, as in the tables of section properties.
NOMINAL LOAD	Magnitude of the load specified by the Code.
NOMINAL RIB HEIGHT	Height of formed steel deck measured from the underside of the lowest point to the top of the highest point.
NOMINAL STRENGTH*	Strength of a structure or component (without the resistance factor or safety factor applied) to resist load effects, as determined in accordance with this Specification.
NONCOMPACT SECTION	Section that can develop the yield stress in its compression elements before local buckling occurs, but cannot develop a rotation capacity of three.
NONDESTRUCTIVE TESTING	Inspection procedure wherein no material is destroyed and integrity of the material or component is not affected.
NOTCH TOUGHNESS	Energy absorbed at a specified temperature as measured in Charpy V-Notch test.
NOTIONAL LOAD	Virtual load applied in a structural analysis to account for destabilizing effects that are not otherwise accounted for in the design provisions.
OUT-OF-PLANE BUCKLING	Limit state of a beam-column bent about its major axis while lateral buckling or lateral-torsional buckling is not prevented by lateral bracing.

ORDINARY CONCENTRICALLY BRACED FRAME (OCBF)	Diagonally braced frame meeting the requirements of Section 14 in which all members of the bracing system are subjected primarily to axial forces.
ORDINARY MOMENT FRAME (OMF)	Moment frame system that meets the requirements of Sec 10.20.11.
OVERLAP CONNECTION	HSS truss connection in which intersecting branch members overlap.
OVER STRENGTH FACTOR, Ω_o	Factor specified by the Code in order to determine the amplified seismic load, where required by these Provisions.
PANEL ZONE	Web area of beam-to-column connection delineated by extension of beam and column flanges through connection, transmitting moment through a shear panel.
PARTIAL-JOINT-PENETRATION GROOVE WELD (PJP)	Groove weld in which the penetration is intentionally less than the complete thickness of the connected element.
PARTIALLY RESTRAINED MOMENT CONNECTION	Connection capable of transferring moment with rotation between connected members that is not negligible.
PASSIVE FIRE PROTECTION	Building materials and systems whose ability to resist the effects of fire does not rely on any outside activating condition or mechanism.
PERFORMANCE-BASED DESIGN	An engineering approach to structural design that is based on agreed-upon performance goals and objectives, engineering analysis and quantitative assessment of alternatives against those design goals and objectives using accepted engineering tools, methodologies and performance criteria.
PERCENT ELONGATION	Measure of ductility, determined in a tensile test as the maximum elongation of the gage length divided by the original gage length.
PERMANENT LOAD	Load in which variations over time are rare or of small magnitude. All other loads are variable loads.
PIPE	See HSS.
PITCH	Longitudinal center-to-center spacing of fasteners. Center-to-center spacing of bolt threads along axis of bolt.

PLASTIC ANALYSIS	Structural analysis based on the assumption of rigid-plastic behavior, in other words, that equilibrium is satisfied throughout the structure and the stress is at or below the yield stress.
PLASTIC HINGE	Yielded zone that forms in a structural member when the plastic moment is attained. The member is assumed to rotate further as if hinged, except that such rotation is restrained by the plastic moment.
PLASTIC MOMENT	Theoretical resisting moment developed within a fully yielded cross section.
PLASTIC STRESS DISTRIBUTION METHOD	Method for determining the stresses in a composite member assuming that the steel section and the concrete in the cross section are fully plastic.
PLASTIFICATION	In an HSS connection, limit state based on an out-of-plane flexural yield line mechanism in the chord at a branch member connection.
PLATE GIRDER	Built-up beam.
PLUG WELD	Weld made in a circular hole in one element of a joint fusing to another element.
PONDING	Retention of water due solely to the deflection of flat roof framing.
POST-BUCKLING STRENGTH	Load or force that can be carried by an element, member, or frame after initial buckling has occurred.
PREQUALIFIED CONNECTION	Connection that complies with the requirements of Appendix N
PRESCRIPTIVE DESIGN	A design method that documents compliance with general criteria established in a Code.
PRETENSIONED JOINT	Joint with high-strength bolts tightened to the specified minimum pretension.
PROPERLY DEVELOPED	Reinforcing bars detailed to yield in a ductile manner before crushing of the concrete occurs. Bars meeting the provisions of Chapter 6 (of Part 6) insofar as development length, spacing and cover shall be deemed to be properly developed.
PROTECTED ZONE	Area of members in which limitations apply to fabrication and attachments.
PROTOTYPE	The connection or brace design that is to be used in the building (SMF, IMF, EBF, and BRBF).

PRYING ACTION	Amplification of the tension force in a bolt caused by leverage between the point of applied load, the bolt and the reaction of the connected elements.
PUNCHING LOAD	Component of branch member force perpendicular to a chord.
PURLIN	Horizontal structural member that supports roof deck and is primarily subjected to bending under vertical loads such as snow, wind or dead loads.
P- δ EFFECT	Effect of loads acting on the deflected shape of a member between joints or nodes.
P- Δ EFFECT	Effect of loads acting on the displaced location of joints or nodes in a structure. In tiered building structures, this is the effect of loads acting on the laterally displaced location of floors and roofs.
QUALITY ASSURANCE	System of shop and field activities and controls implemented by the owner or his/her designated representative to provide confidence to the owner and the building authority that quality requirements are implemented.
QUALITY ASSURANCE PLAN	Written description of qualifications, procedures, quality inspections, resources, and records to be used to provide assurance that the structure complies with the engineer's quality requirements, specifications and contract documents.
QUALITY CONTROL	System of shop and field controls implemented by the fabricator and erector to ensure that contract and company fabrication and erection requirements are met.
RATIONAL ENGINEERING ANALYSIS	Analysis based on theory that is appropriate for the situation, relevant test data if available, and sound engineering judgment.
REDUCED BEAM SECTION	Reduction in cross section over a discrete length that promotes a zone of inelasticity in the member.
REENTRANT	In a cope or weld access hole, a cut at an abrupt change in direction in which the exposed surface is concave.
RELATIVE BRACE	Brace that controls relative movement of two adjacent brace points along length of a beam or column or relative lateral displacement of two stories in a frame.

REQUIRED STRENGTH*	Forces, stresses and deformations acting on the structural component, determined by either structural analysis, for the LRFD or ASD load combinations, as appropriate, or as specified in this Chapter.
RESISTANCE FACTOR, F	Factor that accounts for unavoidable deviations of the nominal strength from the actual strength and for the manner and consequences of failure.
RESTRAINED CONSTRUCTION	Floor and roof assemblies and individual beams in buildings where the surrounding or supporting structure is capable of resisting substantial thermal expansion throughout the range of anticipated elevated temperatures.
REVERSE CURVATURE	See double curvature.
ROOT OF JOINT	Portion of a joint to be welded where the members are closest to each other.
ROTATION CAPACITY	Incremental angular rotation that a given shape can accept prior to excessive load shedding, defined as the ratio of the inelastic rotation attained to the idealized elastic rotation at first yield.
RUPTURE STRENGTH	In a connection, strength limited by tension or shear rupture.
SAFETY FACTOR, Ω	Factor that accounts for deviations of the actual strength from the nominal strength, deviations of the actual load from the nominal load, uncertainties in the analysis that transforms the load into a load effect, and for manner and consequences of failure.
SECOND-ORDER ANALYSIS	Structural analysis in which equilibrium conditions are formulated on the deformed structure; second-order effects (both P- Δ and P- δ , unless specified otherwise) are included.
SECOND-ORDER EFFECT	Effect of loads acting on the deformed configuration of a structure; includes P- Δ effect and P- δ effect.
SEISMIC DESIGN CATEGORY	Classification assigned to a building by the Code based upon its seismic use group and the design spectral response acceleration coefficients.
SEISMIC LOAD RESISTING SYSTEM (SLRS)	Assembly of structural elements in the building that resists seismic loads, including struts, collectors, chords, diaphragms and trusses.

SEISMIC RESPONSE MODIFICATION COEFFICIENT	Factor that reduces seismic load effects to strength level as specified by the Code.
SEISMIC USE GROUP	Classification assigned to a structure based on its use as specified by the Code.
SERVICE LOAD COMBINATION	Load combination under which serviceability limit states are evaluated.
SERVICE LOAD	Load under which serviceability limit states are evaluated.
SERVICEABILITY LIMIT STATE	Limiting condition affecting the ability of a structure to preserve its appearance, maintainability, durability or the comfort of its occupants or function of machinery, under normal usage.
SHEAR BUCKLING	Buckling mode in which a plate element, such as the web of a beam, deforms under pure shear applied in the plane of the plate.
SHEAR CONNECTOR	Headed stud, channel, plate or other shape welded to a steel member and embedded in concrete of a composite member to transmit shear forces at the interface between the two materials.
SHEAR CONNECTOR STRENGTH	Limit state of reaching the strength of a shear connector, as governed by the connector bearing against the concrete in the slab or by the tensile strength of the connector.
SHEAR RUPTURE	Limit state of rupture (fracture) due to shear.
SHEAR WALL	Wall that provides resistance to lateral loads in the plane of the wall and provides stability for the structural system.
SHEAR YIELDING	Yielding that occurs due to shear.
SHEAR YIELDING (PUNCHING)	In an HSS connection, limit state based on out-of-plane shear strength of the chord wall to which branch members are attached.
SHEET STEEL	In a composite floor system, steel used for closure plates or miscellaneous trimming in a formed steel deck.
SHIM	Thin layer of material used to fill a space between faying or bearing surfaces.
SIDESWAY BUCKLING	Limit state of lateral buckling of the tension flange opposite the location of a concentrated compression force.

SIDEWALL CRIPPLING	Limit state of web crippling of the sidewalls of a chord member at a HSS truss connection.
SIDEWALL CRUSHING	Limit state based on bearing strength of chord member sidewall in HSS truss connection.
SIMPLE CONNECTION	Connection that transmits negligible bending moment between connected members.
SINGLE-CONCENTRATED FORCE	Tensile or compressive force applied normal to the flange of a member.
SINGLE CURVATURE	Deformed shape of a beam with no inflection point within the span.
SLENDER-ELEMENT SECTION	Cross section possessing plate components of sufficient slenderness such that local buckling in the elastic range will occur.
SLIP	In a bolted connection, limit state of relative motion of connected parts prior to the attainment of the available strength of the connection.
SLIP-CRITICAL CONNECTION	Bolted connection designed to resist movement by friction on the faying surface of the connection under the clamping forces of the bolts.
SLOT WELD	Weld made in an elongated hole fusing an element to another element.
SNUG-TIGHTENED JOINT	Joint with the connected plies in firm contact as specified in Sec 10.10.
SPECIAL CONCENTRICALLY BRACED FRAME (SCBF)	Diagonally braced frame meeting the requirements of Sec 10.20.13 in which all members of the bracing system are subjected primarily to axial forces.
SPECIAL MOMENT FRAME (SMF)	Moment frame system that meets the requirements of Sec 10.20.9.
SPECIAL PLATE SHEAR WALL (SPSW)	Plate shear wall system that meets the requirements of Sec 10.20.17.
SPECIAL TRUSS MOMENT FRAME (STMF)	Truss moment frame system that meets the requirements of Sec 10.20.12.
SPECIFIED MINIMUM TENSILE STRENGTH	Lower limit of tensile strength specified for a material as defined by ASTM.
SPECIFIED MINIMUM YIELD STRESS	Lower limit of yield stress specified for a material as defined by ASTM.
SPLICE	Connection between two structural elements joined at their ends to form a single, longer element.

STABILITY	Condition reached in the loading of a structural component, frame or structure in which a slight disturbance in the loads or geometry does not produce large displacements.
STIFFENED ELEMENT	Flat compression element with adjoining out-of-plane elements along both edges parallel to the direction of loading.
STIFFENER	Structural element, usually an angle or plate, attached to a member to distribute load, transfer shear or prevent buckling.
STIFFNESS	Resistance to deformation of a member or structure, measured by the ratio of the applied force (or moment) to the corresponding displacement (or rotation).
STRAIN COMPATIBILITY METHOD	Method for determining the stresses in a composite member considering the stress-strain relationships of each material and its location with respect to the neutral axis of the cross section.
STRENGTH LIMIT STATE	Limiting condition affecting the safety of the structure, in which the ultimate load-carrying capacity is reached.
STRESS	Force per unit area caused by axial force, moment, shear or torsion.
STRESS CONCENTRATION	Localized stress considerably higher than average (even in uniformly loaded cross sections of uniform thickness) due to abrupt changes in geometry or localized loading.
STRONG AXIS	Major principal centroidal axis of a cross section.
STRUCTURAL ANALYSIS	Determination of load effects on members and connections based on principles of structural mechanics.
STRUCTURAL COMPONENT	Member, connector, connecting element or assemblage.
STRUCTURAL STEEL	Steel elements as defined in Sec 10.1.3.
STRUCTURAL SYSTEM	An assemblage of load-carrying components that are joined together to provide interaction or interdependence.
STATIC YIELD STRENGTH	Strength of a structural member or connection determined on the basis of testing conducted under slow monotonic loading until failure.

STEEL CORE. AXIAL-FORCE-RESISTING ELEMENT OF BRACES IN BRBF	The steel core contains a yielding segment and connections to transfer its axial force to adjoining elements; it may also contain projections beyond the casing and transition segments between the projections and yielding segment.
T-CONNECTION	HSS connection in which the branch member or connecting element is perpendicular to the main member and in which forces transverse to the main member are primarily equilibrated by shear in the main member.
TENSILE RUPTURE	Limit state of rupture (fracture) due to tension.
TENSILE STRENGTH (OF MATERIAL)	Maximum tensile stress that a material is capable of sustaining as defined by ASTM.
TENSILE STRENGTH (OF MEMBER)	Maximum tension force that a member is capable of sustaining.
TENSILE YIELDING	Yielding that occurs due to tension.
TENSION AND SHEAR RUPTURE	In a bolt, limit state of rupture (fracture) due to simultaneous tension and shear force.
TENSION FIELD ACTION	Behavior of a panel under shear in which diagonal tensile forces develop in the web and compressive forces develop in the transverse stiffeners in a manner similar to a Pratt truss.
TESTED CONNECTION	Connection that complies with the requirements of Appendix O.
THERMALLY CUT	Cut with gas, plasma or laser.
TIE PLATE	Plate element used to join two parallel components of a built-up column, girder or strut rigidly connected to the parallel components and designed to transmit shear between them.
TOE OF FILLET	Junction of a fillet weld face and base metal. Tangent point of a rolled section fillet.
TORSIONAL BRACING	Bracing resisting twist of a beam or column.
TORSIONAL BUCKLING	Buckling mode in which a compression member twists about its shear center axis.
TORSIONAL YIELDING	Yielding that occurs due to torsion.
TRANSVERSE REINFORCEMENT	Steel reinforcement in the form of closed ties or welded wire fabric providing confinement for the concrete surrounding the steel shape core in an encased concrete composite column.

TRANSVERSE STIFFENER	Web stiffener oriented perpendicular to the flanges, attached to the web.
TUBING	See HSS.
TURN-OF-NUT METHOD	Procedure whereby the specified pretension in high-strength bolts is controlled by rotating the fastener component a predetermined amount after the bolt has been snug tightened.
UNBRACED LENGTH	Distance between braced points of a member, measured between the centers of gravity of the bracing members.
UNEVEN LOAD DISTRIBUTION	In an HSS connection, condition in which the load is not distributed through the cross section of connected elements in a manner that can be readily determined.
UNFRAMED END	The end of a member not restrained against rotation by stiffeners or connection elements.
UNRESTRAINED CONSTRUCTION	Floor and roof assemblies and individual beams in buildings that are assumed to be free to rotate and expand throughout the range of anticipated elevated temperatures.
UNSTIFFENED ELEMENT	Flat compression element with an adjoining out-of-plane element along one edge parallel to the direction of loading.
V-BRACED FRAME	Concentrically braced frame (SCBF, OCBF or BRBF) in which a pair of diagonal braces located either above or below a beam is connected to a single point within the clear beam span. Where the diagonal braces are below the beam, the system is also referred to as an inverted-V-braced frame.
VARIABLE LOAD	Load not classified as permanent load.
VERTICAL BRACING SYSTEM	System of shear walls, braced frames or both, extending through one or more floors of a building.
WEAK AXIS	Minor principal centroidal axis of a cross section.
WEATHERING STEEL	High-strength, low-alloy steel that, with suitable precautions, can be used in normal atmospheric exposures (not marine) without protective paint coating.
WEB BUCKLING	Limit state of lateral instability of a web.

WEB COMPRESSION BUCKLING	Limit state of out-of-plane compression buckling of the web due to a concentrated compression force.
WEB SIDESWAY BUCKLING	Limit state of lateral buckling of the tension flange opposite the location of a concentrated compression force.
WELD METAL	Portion of a fusion weld that has been completely melted during welding. Weld metal has elements of filler metal and base metal melted in the weld thermal cycle.
WELD ROOT	See root of joint.
X-BRACED FRAME	Concentrically braced frame (OCBF or SCBF) in which a pair of diagonal braces crosses near the mid-length of the braces.
Y-BRACED FRAME	Eccentrically braced frame (EBF) in which the stem of the Y is Link the EBF system.
Y-CONNECTION	HSS connection in which the branch member or connecting element is not perpendicular to the main member and in which forces transverse to the main member are primarily equilibrated by shear in the main member.
YIELD MOMENT	In a member subjected to bending, the moment at which the extreme outer fiber first attains the yield stress.
YIELD POINT	First stress in a material at which an increase in strain occurs without an increase in stress as defined by ASTM.
YIELD STRENGTH	Stress at which a material exhibits a specified limiting deviation from the proportionality of stress to strain as defined by ASTM.
YIELD STRESS	Generic term to denote either yield point or yield strength, as appropriate for the material.
YIELDING	Limit state of inelastic deformation that occurs after the yield stress is reached.
YIELDING (PLASTIC MOMENT)	Yielding throughout the cross section of a member as the bending moment reaches the plastic moment.
YIELDING (YIELD MOMENT)	Yielding at the extreme fiber on the cross section of a member when the bending moment reaches the yield moment.

Notes:

- (1) Terms designated with * are usually qualified by the type of load effect, for example, nominal tensile strength, available compressive strength, design flexural strength.
- (2) Terms designated with ** are usually qualified by the type of component, for example, web local buckling, flange local bending.

10.1.2.3 Referenced specifications, codes and standards

The following specifications, codes and standards are referenced in this Specification.

ACI International (ACI)

ACI 318	Building Code Requirements for Structural Concrete and Commentary
ACI 318M	Metric Building Code Requirements for Structural Concrete and Commentary

American Institute of Steel Construction, Inc. (AISC)

AISC 303	Code of Standard Practice for Steel Buildings and Bridges
ANSI/AISC 341	Seismic Provisions for Structural Steel Buildings
ANSI/AISC N690	Specification for the Design, Fabrication and Erection of Steel Safety-Related Structures for Nuclear Facilities, including Supplement No. 2
ANSI/AISC N690L	Load and Resistance Factor Design Specification for Steel Safety-Related Structures for Nuclear Facilities

American Society of Civil Engineers (ASCE)

SEI/ASCE 7	Minimum Design Loads for Buildings and Other Structures
ASCE/SFPE 29	Standard Calculation Methods for Structural Fire Protection

American Society of Mechanical Engineers (ASME)

ASME B18.2.6	Fasteners for Use in Structural Applications
ASME B46.1	Surface Texture, Surface Roughness, Waviness, and Lay

American Iron and Steel Institute (AISI)

North American Specification for the Design of Cold Formed Steel Structural Members (AISI/COS/NASPEC 2001).

Code of Standard Practice for Cold-Formed Steel Structural Framing

ASTM International (ASTM)

ASTM A6/A6M-04a	Standard Specification for General Requirements for Rolled Structural Steel Bars, Plates, Shapes, and Sheet Piling
ASTM A36/A36M	Standard Specification for Carbon Structural Steel
ASTM A53/A53M	Standard Specification for Pipe, Steel, Black and Hot-Dipped, Zinc-Coated, Welded and Seamless
ASTM A193/A193M	Standard Specification for Alloy-Steel and Stainless Steel Bolting Materials for High-Temperature Service
ASTM A194/A194M	Standard Specification for Carbon and Alloy Steel Nuts for Bolts for High Pressure or High-Temperature Service, or Both
ASTM A216/A216M	Standard Specification for Steel Castings, Carbon, Suitable for Fusion Welding, for High Temperature Service
ASTM A242/A242M	Standard Specification for High-Strength Low-Alloy Structural Steel
ASTM A283/A283M	Standard Specification for Low and Intermediate Tensile Strength Carbon Steel Plates
ASTM A307	Standard Specification for Carbon Steel Bolts and Studs, 60,000 psi Tensile Strength
ASTM A325	Standard Specification for Structural Bolts, Steel, Heat Treated, 120/105 ksi Minimum Tensile Strength
ASTM A325M	Standard Specification for High-Strength Bolts for Structural Steel Joints (Metric)
ASTM A354	Standard Specification for Quenched and Tempered Alloy Steel Bolts, Studs, and Other Externally Threaded Fasteners
ASTM A370	Standard Test Methods and Definitions for Mechanical Testing of Steel Products
ASTM A449	Standard Specification for Quenched and Tempered Steel Bolts and Studs
ASTM A490	Standard Specification for Heat-Treated Steel Structural Bolts, 150 ksi Minimum Tensile Strength
ASTM A490M	Standard Specification for High-Strength Steel Bolts, Classes 10.9 and 10.9.3, for Structural Steel Joints (Metric)
ASTM A500	Standard Specification for Cold-Formed Welded and Seamless Carbon Steel Structural Tubing in Rounds and Shapes
ASTM A501	Standard Specification for Hot-Formed Welded and Seamless Carbon Steel Structural Tubing
ASTM A502	Standard Specification for Steel Structural Rivets

ASTM A514/A514M	Standard Specification for High-Yield Strength, Quenched and Tempered Alloy Steel Plate, Suitable for Welding
ASTM A529/A529M	Standard Specification for High-Strength Carbon-Manganese Steel of Structural Quality
ASTM A563	Standard Specification for Carbon and Alloy Steel Nuts
ASTM A563M	Standard Specification for Carbon and Alloy Steel Nuts [Metric]
ASTM A568/A568M	Standard Specification for Steel, Sheet, Carbon, and High-Strength, Low-Alloy, Hot-Rolled and Cold-Rolled, General Requirements for
ASTM A572/A572M	Standard Specification for High-Strength Low-Alloy Columbium-Vanadium Structural Steel.
ASTM A588/A588M	Standard Specification for High-Strength Low-Alloy Structural Steel with 345 MPa Minimum Yield Point to 100 mm Thick
ASTM A606	Standard Specification for Steel, Sheet and Strip, High-Strength, Low- Alloy, Hot-Rolled and Cold-Rolled, with Improved Atmospheric Corrosion Resistance
ASTM A618/A618M	Standard Specification for Hot-Formed Welded and Seamless High-Strength Low-Alloy Structural Tubing
ASTM A673/A673M	Standard Specification for Sampling Procedure for Impact Testing of Structural Steel
ASTM A668/A668M	Standard Specification for Steel Forgings, Carbon and Alloy, for General Industrial Use
ASTM A709/A709M	Standard Specification for Carbon and High-Strength Low-Alloy Structural Steel Shapes, Plates, and Bars and Quenched-and-Tempered Alloy Structural Steel Plates for Bridges
ASTM A751	Standard Test Methods, Practices, and Terminology for Chemical Analysis of Steel Products
ASTM A847	Standard Specification for Cold-Formed Welded and Seamless High-Strength, Low-Alloy Structural Tubing with Improved Atmospheric Corrosion Resistance
ASTM A852/A852M	Standard Specification for Quenched and Tempered Low-Alloy Structural Steel Plate with 485 MPa Minimum Yield Strength to 100 mm Thick
ASTM A913/A913M	Standard Specification for High-Strength Low-Alloy Steel Shapes of Structural Quality, Produced by Quenching and Self-Tempering Process (QST)
ASTM A992/A992M	Standard Specification for Structural Steel Shapes

ASTM A1011/A1011M	Standard Specification for Steel, Sheet and Strip, Hot-Rolled, Carbon, Structural, High-Strength Low-Alloy and High-Strength Low-Alloy with Improved Formability
ASTM C33	Standard Specification for Concrete Aggregates
ASTM C330	Standard Specification for Lightweight Aggregates for Structural Concrete
ASTM E119	Standard Test Methods for Fire Tests of Building Construction and Materials
ASTM E709	Standard Guide for Magnetic Particle Examination
ASTM F436	Standard Specification for Hardened Steel Washers
ASTM F959	Standard Specification for Compressible-Washer-Type Direct Tension Indicators for Use with Structural Fasteners
ASTM F1554	Standard Specification for Anchor Bolts, Steel, 36, 55, and 105 ksi Yield Strength
ASTM F1852	Standard Specification for “Twist-Off” Type Tension Control Structural Bolt/Nut/Washer Assemblies, Steel, Heat Treated, 120/105 ksi Minimum Tensile Strength

American Welding Society (AWS)

AWS D1.1/D1.1M	Structural Welding Code–Steel
AWS A5.1	Specification for Carbon Steel Electrodes for Shielded Metal Arc Welding
AWS A5.5	Specification for Low-Alloy Steel Electrodes for Shielded Metal Arc Welding
AWS A5.17/A5.17M	Specification for Carbon Steel Electrodes and Fluxes for Submerged Arc Welding
AWS A5.18	Specification for Carbon Steel Electrodes and Rods for Gas Shielded Arc Welding
AWS A5.20	Specification for Carbon Steel Electrodes for Flux Cored Arc Welding
AWS A5.23/A5.23M	Specification for Low-Alloy Steel Electrodes and Fluxes for Submerged Arc Welding
AWS A5.25/A5.25M	Specification for Carbon and Low-Alloy Steel Electrodes and Fluxes for Electroslag Welding
AWS A5.26/A5.26M	Specification for Carbon and Low-Alloy Steel Electrodes for Electrode Gas Welding
AWS A5.28	Specification for Low-Alloy Steel Electrodes and Rods for Gas Shielded Arc Welding
AWS A5.29	Specification for Low-Alloy Steel Electrodes for Flux Cored Arc Welding

Research Council on Structural Connections (RCSC)

Specification for Structural Joints Using ASTM A325 or A490 Bolts, 2004

Bangladesh Standards and Testing Institute (BSTI)

BDS 1031	Mild Steel (MS) Pipe and Galvanized Iron (GI) Pipe
BDS ISO 6935Parts 1 and 2	Steel for Reinforcement of Concrete.
BDS 1122	GP Sheet with Corrugation
BDS EN 197- 1Cement Part 1	Composition. Specifications and Conformity Criteria for Common Cement
BDS 208	Common Building Clay Bricks
BDS ISO 13006	Ceramic Tiles
BDS 1825	Aluminium and Aluminium Alloys - Extruded Rod/Bar Tube and Profiles - Tolerances on Dimensions and Form.

10.1.3 Material

10.1.3.1 Structural steel materials

- (a) Regular Structural Steel: Material test reports from an acceptable testing laboratory shall constitute sufficient evidence of conformity with one of the above listed ASTM standards. For hot-rolled structural shapes, plates, and bars, such tests shall be made in accordance with ASTM A6/A6M; for sheets, such tests shall be made in accordance with ASTM A568/A568M; for tubing and pipe, such tests shall be made in accordance with the requirements of the applicable ASTM standards listed above for those product forms. If requested, the fabricator shall provide an affidavit stating that the structural steel furnished meets the requirements of the grade specified.

Structural steel material conforming to one of the following specifications is approved for use under this Specification:

(i) Hot-rolled structural shapes

ASTM A36/A36M, ASTM A529/A529M, ASTM A572/A572M, ASTM A588/A588M, ASTM A709/A709M, ASTM A913/A913M, ASTM A992/ A992M

(ii) Structural tubing

ASTM A500, ASTM A501, ASTM A618, ASTM A847, BDS 1031

(iii) Pipe

ASTM A53/A53M, Gr. B, BDS 1031

(iv) Plates

ASTM A36/A36M, ASTM A242/A242M, ASTM A283/A283M, ASTM A514/A514M, ASTM A529/A529M, ASTM A572/A572M, ASTM A588/A588M, ASTM A709/A709M, ASTM A852/A852M, ASTM A1011/A1011M, BDS 1122

(v) Bars

ASTM A36/A36M, ASTM A529/A529M, ASTM A572/A572M, ASTM A709/A709M, BDS ISO 6935-1, BDS ISO 6935-2

(vi) Sheets

ASTM A606, A1011/A1011M SS, HSLAS, AND HSLAS-F, BDS 1122

- (b) Unidentified Steel: Unidentified steel free of injurious defects is permitted to be used for unimportant members or details, where the precise physical properties and weldability of the steel would not affect the strength of the structure.
- (c) Rolled Heavy Shapes: ASTM A6/A6M hot-rolled shapes with a flange thickness exceeding 50 mm, used as members subject to primary (computed) tensile forces due to tension or flexure and spliced using complete-joint-penetration groove welds that fuse through the thickness of the member, shall be specified as follows. The contract documents shall require that such shapes be supplied with Charpy V-Notch (CVN) impact test results in accordance with ASTM A6/A6M, Supplementary Requirement S30, Charpy V-Notch Impact Test for Structural Shapes – Alternate Core Location. The impact test shall meet a minimum average value of 27 Joules absorbed energy at +21⁰ C.

The above requirements do not apply if the splices and connections are made by bolting. The above requirements do not apply to hot-rolled shapes with a flange thickness exceeding 50 mm that have shapes with flange or web elements less than 50 mm thick welded with complete-joint-penetration groove welds to the face of the shapes with thicker elements.

- (d) Built-Up Heavy Shapes: Built-up cross-sections consisting of plates with a thickness exceeding 50 mm, used as members subject to primary (computed) tensile forces due to tension or flexure and spliced or connected to other members using complete-joint-penetration groove welds that fuse through the thickness of the plates, shall be specified as follows. The contract documents shall require that the steel be supplied with Charpy V-Notch impact test results in accordance with ASTM A6/A6M, Supplementary Requirement S5, Charpy V-Notch Impact Test. The impact test shall be conducted in accordance with ASTM A673/A673M, Frequency P, and shall meet a minimum average value of 27 Joules absorbed energy at +21⁰ C.

The above requirements also apply to built-up cross-sections consisting of plates exceeding 50 mm that are welded with complete-joint-penetration groove welds to the face of other sections.

- (e) Cold Form Sections: Specifications for cold form shapes regarding their use as structural members is not covered in Sec 10. For such type of structural steel, AISI standard (AISI/COS/NASPEC 2001) or equivalent may be followed.

10.1.3.2 Steel castings and forgings

Cast steel shall conform to ASTM A216/A216M, Gr. WCB with Supplementary Requirement S11. Steel forgings shall conform to ASTM A668/A668M. Test reports produced in accordance with the above reference standards shall constitute sufficient evidence of conformity with such standards.

10.1.3.3 Bolts, washers and nuts

Bolt, washer, and nut material conforming to one of the following ASTM specifications is approved for use under this Specification:

- (1) Bolts: ASTM A307, ASTM A325, ASTM A325M, ASTM A449, ASTM A490, ASTM A490M, ASTM F1852
- (2) Nuts: ASTM A194/A194M, ASTM A563, ASTM A563M
- (3) Washers: ASTM F436, ASTM F436M
- (4) Compressible-Washer-Type Direct Tension Indicators: ASTM F959, ASTM F959M

10.1.3.4 Anchor rods and threaded rods

Anchor rod and threaded rod material conforming to one of the following ASTM specifications is approved for use under this Specification:

ASTM A36/A36M, ASTM A193/A193M, ASTM A354, ASTM A449, ASTM A572/A572M, ASTM A588/A588M, ASTM F1554

A449 material is acceptable for high-strength anchor rods and threaded rods of any diameter.

Threads on anchor rods and threaded rods shall conform to the Unified Standard Series of ASME B18.2.6 and shall have Class 2A tolerances.

10.1.3.5 Filler metal and flux for welding

Filler metals and fluxes shall conform to one of the following specifications of the American Welding Society: AWS A5.1, AWS A5.5, AWS A5.17/A5.17M, AWS A5.18, AWS A5.20, AWS A5.23/A5.23M, AWS A5.25/A5.25M, AWS A5.26/A5.26M, AWS A5.28, AWS A5.29, AWS A5.32/A5.32M

10.1.3.6 Stud shear connectors

Steel stud shear connectors shall conform to the requirements of Structural Welding Code–Steel, AWS D1.1.

10.1.4 Structural Design Drawings and Specifications

The design drawings and specifications shall meet the requirements specified in this specification (Sections 10.1 to 10.20) and shall be prepared and presented in an internationally approved standard in accordance with the provisions of Sec 10.13, except for deviations specifically identified in the design drawings and/or specifications and approved by an appropriate authority.

10.2 General Design Requirements

The general requirements for the analysis and design of steel buildings and structures that are applicable to all Sections of Chapter 10 Part 6 are given in this Section.

10.2.1 General Provisions

The design of members and connections shall be consistent with the intended behavior of the framing system and the assumptions made in the structural analysis. Unless restricted by the Code, lateral load resistance and stability may be provided by any combination of members and connections.

10.2.2 Loads and Load Combinations

The loads and load combinations shall be as stipulated in Chapter 2 Part 6 of this Code. For design purposes, the nominal loads shall be taken as the loads stipulated in the Chapter 2

10.2.3 Design Basis

Designs shall be made according to the provisions for Load and Resistance Factor Design (LRFD) or to the provisions for Allowable Strength Design (ASD).

10.2.3.1 Required strength

The required strength of structural members and connections shall be determined by structural analysis for the appropriate load combinations as stipulated in Chapter 2 of Part 6. Design by elastic, inelastic or plastic analysis is permitted. Provisions for inelastic and plastic analysis are as stipulated in Sec 10.15, Inelastic Analysis and Design. The provisions for moment redistribution in continuous beams in Sec 10.15.3 are permitted for elastic analysis only.

10.2.3.2 Limit states

Design shall be based on the principle that no applicable strength or serviceability limit state shall be exceeded when the structure is subjected to all appropriate load combinations.

10.2.3.3 Design for strength using load and resistance factor design (LRFD)

Design according to the provisions for Load and Resistance Factor Design (LRFD) satisfies the requirements of this Specification when the design strength of each structural component equals or exceeds the required strength determined on the basis of the LRFD load combinations as specified in Chapter 2 of Part 6. All provisions of this Specification, except for those in Sec 10.2.3.4, shall apply.

Design shall be performed in accordance with Eq.6.10.1:

$$R_u \leq \phi R_n \quad (6.10.1)$$

Where,

R_u = required strength (LRFD)

R_n = nominal strength, specified in Sections 10.2 to 10.20

ϕ = resistance factor, specified in Sections 10.2 to 10.20

ϕR_n = design strength

10.2.3.4 Design for strength using allowable strength design (ASD)

Design according to the provisions for Allowable Strength Design (ASD) satisfies the requirements of this Specification when the allowable strength of each structural component equals or exceeds the required strength determined on the basis of the ASD load combinations as specified in Chapter 2 of Part 6. All provisions of this Specification, except those of Sec 10.2.3.3, shall apply.

Design shall be performed in accordance with Eq.6.10.2:

$$R_a \leq R_n / \Omega \quad (6.10.2)$$

Where,

R_a = required strength (ASD)

R_n = nominal strength, specified in Sections 10.2 to 10.20

Ω = safety factor, specified in Sections 10.2 to 10.20

R_n/Ω = allowable strength

10.2.3.5 Design for stability

Stability of the structure and its elements shall be determined in accordance with Sec 10.3.

10.2.3.6 Design for connection

Connection elements shall be designed in accordance with the provisions of Sections 10.10 and 10.11. The forces and deformations used in design shall be consistent with the intended performance of the connection and the assumptions used in the structural analysis.

10.2.3.6.1 Simple connection

A simple connection transmits a negligible moment across the connection. In the analysis of the structure, simple connections may be assumed to allow unrestrained relative rotation between the framing elements being connected. A simple connection shall have sufficient rotation capacity to accommodate the required rotation determined by the analysis of the structure. Inelastic rotation of the connection is permitted.

10.2.3.6.2 Moment connection

A moment connection transmits moment across the connection. Two types of moment connections, FR and PR, are permitted, as specified below.

- (a) Fully-Restrained (FR) Moment Connections: A fully-restrained (FR) moment connection transfers moment with a negligible relative rotation between the connected members. In the analysis of the structure, the connection may be assumed to allow no relative rotation. An FR connection shall have sufficient strength and stiffness to maintain the angle between the connected members at the strength limit states.

- (b) Partially-Restrained (PR) Moment Connections: Partially-restrained (PR) moment connections transfer moments, but the relative rotation between connected members is not negligible. In the analysis of the structure, the force-deformation response characteristics of the connection shall be included. The response characteristics of a PR connection shall be documented in the technical literature or established by analytical or experimental means. The component elements of a PR connection shall have sufficient strength, stiffness, and deformation capacity at the strength limit states.

10.2.3.7 Design for serviceability

The overall structure and the individual members, connections and connectors shall be checked for serviceability. Performance requirements for serviceability design are given in Sec 10.12.

10.2.3.8 Design for ponding

The roof system shall be investigated through structural analysis to assure adequate strength and stability under ponding conditions, unless the roof surface is provided with a slope of 20 mm per meter or greater toward points of free drainage or an adequate system of drainage is provided to prevent the accumulation of water. Methods of checking ponding are given in Sec 10.16.

10.2.3.9 Design for fatigue

Fatigue shall be considered in accordance with Sec 10.17, Design for Fatigue, for members and their connections subject to repeated loading. Fatigue need not be considered for seismic effects or for the effects of wind loading on normal building lateral load resisting systems and building enclosure components.

10.2.3.10 Design for fire conditions

Two methods of design for fire conditions are provided in Sec 10.18, Structural Design for Fire Conditions: Qualification Testing and Engineering Analysis. Compliance with the fire protection requirements in Part 4 of this Code shall be required in addition to the requirements of Sec 10.18.

10.2.3.11 Design for corrosion effects

Where corrosion may impair the strength or serviceability of a structure, structural components shall be designed to tolerate corrosion or shall be protected against corrosion.

10.2.3.12 Design wall thickness for HSS

The design wall thickness, t , shall be used in calculations involving the wall thickness of hollow structural sections (HSS). The design wall thickness, t , shall be taken equal to 0.93 times the nominal wall thickness for electric-resistance-welded (ERW) HSS and equal to the nominal thickness for submerged-arc-welded (SAW) HSS.

10.2.3.13 Gross and net area determination

10.2.3.13.1 Gross area

The gross area, A_g , of a member is the total cross-sectional area.

10.2.3.13.2 Net area

The net area, A_n of a member is the sum of the products of the thickness and the net width of each element computed as follows:

In computing net area for tension and shear, the width of a bolt hole shall be taken as 2 mm greater than the nominal dimension of the hole.

For a chain of holes extending across a part in any diagonal or zigzag line, the net width of the part shall be obtained by deducting from the gross width the sum of the diameters or slot dimensions as provided in Sec 10.10.3.2, of all holes in the chain, and adding, for each gage space in the chain, the quantity $s^2/(4g)$.

Where,

s = longitudinal center-to-center spacing (pitch) of any two consecutive holes, mm.

g = transverse center-to-center spacing (gage) between fastener gage lines, mm.

For angles, the gage for holes in opposite adjacent legs shall be the sum of the gages from the back of the angles less the thickness.

For slotted HSS welded to a gusset plate, the net area, A_n , is the gross area the product of the thickness and the total width of material that is removed to form the slot.

In determining net area across plug or slot welds, the weld metal shall not be considered as adding to net area.

10.2.4 Classification of Sections for Local Buckling

Sections are classified as compact, noncompact, or slender-element sections. For a section to qualify as compact its flanges must be continuously connected to the web or webs and the width-thickness ratios of its compression elements must not exceed the limiting width-thickness ratios λ_p from Table 6.10.1. If the width- thickness ratio of one or more compression elements exceeds λ_p , but does not exceed λ_r from Table 6.10.1, the section is noncompact. If the width-thickness ratio of any element exceeds λ_r , the section is referred to as a slender-element section.

10.2.4.1 Unstiffened elements

For unstiffened elements supported along only one edge parallel to the direction of the compression force, the width shall be taken as follows:

- (a) For flanges of I-shaped members and tees, the width b is one-half the full-flange width, b_f .
- (b) For legs of angles and flanges of channels and zees, the width b is the full nominal dimension.

- (c) For plates, the width b is the distance from the free edge to the first row of fasteners or line of welds.
- (d) For stems of tees, d is taken as the full nominal depth of the section.

10.2.4.2 Stiffened elements

For stiffened elements supported along two edges parallel to the direction of the compression force, the width shall be taken as follows:

- (a) For webs of rolled or formed sections, h is the clear distance between flanges less the fillet or corner radius at each flange; h_c is twice the distance from the centroid to the inside face of the compression flange less the fillet or corner radius.
- (b) For webs of built-up sections, h is the distance between adjacent lines of fasteners or the clear distance between flanges when welds are used, and h_c is twice the distance from the centroid to the nearest line of fasteners at the compression flange or the inside face of the compression flange when welds are used; h_p is twice the distance from the plastic neutral axis to the nearest line of fasteners at the compression flange or the inside face of the compression flange when welds are used.
- (c) For flange or diaphragm plates in built-up sections, the width b is the distance between adjacent lines of fasteners or lines of welds.
- (d) For flanges of rectangular hollow structural sections (HSS), the width b is the clear distance between webs less the inside corner radius on each side. For webs of rectangular HSS, h is the clear distance between the flanges less the inside corner radius on each side. If the corner radius is not known, b and h shall be taken as the corresponding outside dimension minus three times the thickness. The thickness, t , shall be taken as the design wall thickness, per Sec 10.2.3.12.
- (e) For tapered flanges of rolled sections, the thickness is the nominal value halfway between the free edge and the corresponding face of the web.

10.2.5 Fabrication, Erection and Quality

Shop drawings, fabrication, shop painting, erection, and quality control shall meet the requirements stipulated in Sec10.13, Fabrication, Erection, and Quality Control.

10.3 Stability Analysis and Design

This Section addresses general requirements for the stability analysis and design of members and frames of steel buildings and structures.

10.3.1 Stability Design Requirements

Stability shall be provided for the structure as a whole and for each of its elements. Any method that considers the influence of second-order effects (including P- Δ and P- δ effects),

flexural, shear and axial deformations, geometric imperfections, and member stiffness reduction due to residual stresses on the stability of the structure and its elements is permitted. The methods prescribed in this Section and Sec 10.14: Direct Analysis Method, satisfy these requirements. All component and connection deformations that contribute to the lateral displacements shall be considered in the stability analysis. In structures designed by elastic analysis, individual member stability and stability of the structure as a whole are provided jointly by:

- (a) Calculation of the required strengths for members, connections and other elements using one of the methods specified in Sec 10.3.2.2, and
- (b) Satisfaction of the member and connection design requirements in this specification based upon those required strengths.

In structures designed by inelastic analysis, the provisions of Sec 10.15 shall be satisfied.

10.3.1.1 Member stability design requirements

Individual member stability is provided by satisfying the provisions of Sections 10.5 to 10.11. Where elements are designed to function as braces to define the unbraced length of columns and beams, the bracing system shall have sufficient stiffness and strength to control member movement at the braced points. Methods of satisfying this requirement are provided in Sec 10.19.

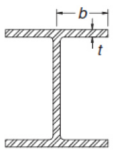
10.3.1.2 System stability design requirements

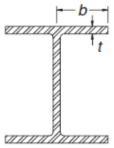
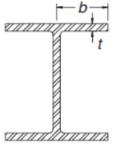
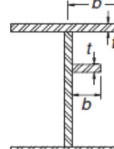
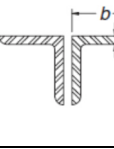
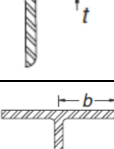
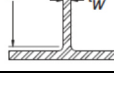

Lateral stability shall be provided by moment frames, braced frames, shear walls, and/or other equivalent lateral load resisting systems. The overturning effects of drift and the destabilizing influence of gravity loads shall be considered. Force transfer and load sharing between elements of the framing systems shall be considered. Braced-frame and shear-wall systems, moment frames, gravity framing systems, and combined systems shall satisfy the following specific requirements:

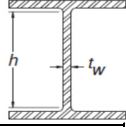
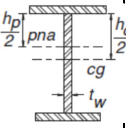
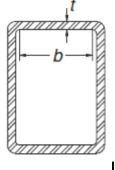
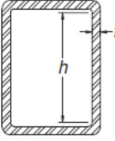
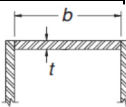
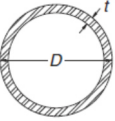
10.3.1.2.1 Braced-frame and shear-wall systems

In structures where lateral stability is provided solely by diagonal bracing, shear walls, or equivalent means, the effective length factor, K , for compression members shall be taken as 1.0, unless structural analysis indicates a smaller value appropriate. In braced-frame systems, it is permitted to design columns, beams, and diagonal members as a vertically cantilevered, simply connected truss.

Table 6.10.1: Limiting Width-Thickness Ratios for Compression Elements

	Case	Description of Element	Width Thickness Ratio	Limiting Width Thickness Ratio		Example
				λ_p (Compact)	λ_r (Noncompact)	
Unstiffened Element	1	Flexure in flanges of rolled I-shaped sections and channels	b/t	$0.38 \sqrt{E/F_y}$	$1.0 \sqrt{E/F_y}$	

	Case	Description of Element	Width Thickness Ratio	Limiting Width Thickness Ratio		Example
				λ_p (Compact)	λ_r (Noncompact)	
Unstiffened Elements	2	Flexure in flanges of doubly and singly symmetric I-shaped built-up sections	b/t	$0.38 \sqrt{E/F_y}$	$0.95 \sqrt{k_c E/F_y}^{[a]}$], [b]	
	3	Uniform compression in flanges of rolled I-shaped sections, plates projecting from rolled I-shaped sections; Outstanding legs of pairs of angles in continuous contact and flanges of channels	b/t	NA	$0.56 \sqrt{E/F_y}$	
	4	Uniform compression in flanges of built-up I-shaped sections and plates or angle legs projecting from built-up I-shaped section	b/t	NA	$0.64 \sqrt{k_c E/F_y}^{[a]}$]	
	5	Uniform compression in legs of single angles, legs of double angles with separators, and all other unstiffened elements	b/t	NA	$0.45 \sqrt{E/F_y}$	
	6	Flexure in legs of single angles	b/t	$0.54 \sqrt{E/F_y}$	$0.91 \sqrt{E/F_y}$	
	Stiffened Elements	7	Flexure in flanges of tees	b/t	$0.38 \sqrt{E/F_y}$	$1.0 \sqrt{E/F_y}$
8		Uniform compression in stems of tees	d/t	NA	$0.75 \sqrt{E/F_y}$	
9		Flexure in webs of doubly symmetric I-shaped sections	h/t_w	$3.76 \sqrt{E/F_y}$	$5.70 \sqrt{E/F_y}$	

	Case	Description of Element	Width Thickness Ratio	Limiting Width Thickness Ratio		Example
				λ_p (Compact)	λ_r (Noncompact)	
stiffened Elements	10	Uniform compression in webs of doubly symmetric I-shaped sections	h/t_w	NA	$1.49 \sqrt{E/F_y}$	
	11	Flexure in webs of singly symmetric I-shaped sections	h_c/t_w	$\frac{h_c}{h_p} \sqrt{\frac{E}{F_y}}$ $\left(0.54 \frac{M_p}{M_y}\right)^2$ $\leq \lambda_r$	$5.70 \sqrt{E/F_y}$	
	12	Uniform compression in flanges of rectangular box and hollow structural sections of uniform thickness subject to bending or compression; flange cover plates and diaphragm plates between lines of fasteners or welds	b/t	$1.12 \sqrt{E/F_y}$	$1.40 \sqrt{E/F_y}$	
	13	Flexure in webs of rectangular HSS	h/t	$2.42 \sqrt{E/F_y}$	$5.70 \sqrt{E/F_y}$	
	14	Uniform compression in all other stiffened elements	b/t	NA	$1.49 \sqrt{E/F_y}$	
	15	Circular hollow sections in uniform compression in flexure	D/t D/t	NA $0.07 \sqrt{E/F_y}$	$0.11E/F_y$ $0.31E/F_y$	

^(a) $k_c = \frac{4}{\sqrt{h/t_w}}$ But shall not be taken less than 0.35 nor greater than 0.76 for calculation purposes. (See Cases 2 and 4)

^(b) $F_L = 0.7F_y$ For minor-axis bending, major axis bending of slender-web built-up I-shaped members, and major axis bending of compact and noncompact web built-up I-shaped members with $\frac{S_{xt}}{S_{xc}} \geq 0.7$; $F_L = F_y \frac{S_{xt}}{S_{xc}} \geq 0.5F_y$ for major-axis bending of compact and noncompact web built-up I-shaped members with $\frac{S_{xt}}{S_{xc}} < 0.7$ (See Case 2)

10.3.1.2.2 Moment frame systems

In frames where lateral stability is provided by the flexural stiffness of connected beams and columns, the effective length factor K or elastic critical buckling stress, F_e , for columns and beam-columns shall be determined as specified in Sec 10.3.2.

10.3.1.2.3 Gravity framing systems

Columns in gravity framing systems shall be designed based on their actual length ($K = 1.0$) unless analysis shows that a smaller value may be used. The lateral stability of gravity framing systems shall be provided by moment frames, braced frames, shear walls, and/or other equivalent lateral load resisting systems. $P-\Delta$ effects due to load on the gravity columns shall be transferred to the lateral load resisting systems and shall be considered in the calculation of the required strengths of the lateral load resisting systems.

10.3.1.2.4 Combined systems

The analysis and design of members, connections and other elements in combined systems of moment frames, braced frames, and/or shearwalls and gravity frames shall meet the requirements of the irrespective systems.

10.3.2 Calculation of Required Strengths

Except as permitted in Sec 10.3.2.2.2, required strengths shall be determined using a second-order analysis as specified in Sec 10.3.2.1. Design by either second-order or first-order analysis shall meet the requirements specified in Sec 10.3.2.2.

10.3.2.1 Methods of second-order analysis

Second-order analysis shall conform to the requirements in this Section.

10.3.2.1.1 General second-order elastic analysis

Any second-order elastic analysis method that considers both $P-\Delta$ and $P-\delta$ effects may be used. The Amplified First-Order Elastic Analysis Method defined in Sec 10.3.2.1.2 is an accepted method for second-order elastic analysis of braced, moment, and combined framing systems.

10.3.2.1.2 Second-order analysis by amplified first-order elastic analysis

The following is an approximate second-order analysis procedure for calculating the required flexural and axial strengths in members of lateral load resisting systems. The required second-order flexural strength, M_r , and axial strength, P_r , shall be determined as follows:

$$M_r = B_1 M_{nt} + B_2 M_{lt} \quad (6.10.3a)$$

$$P_r = P_{nt} + B_2 P_{lt} \quad (6.10.3b)$$

Where,

$$B_1 = \frac{C_m}{1 - \alpha P_r / P_{e1}} \geq 1 \quad (6.10.4)$$

For members subjected to axial compression, B_1 may be calculated based on first-order estimate $P_r = P_{nt} + P_{lt}$.

For members in which $B_1 \leq 1.05$, it is conservative to amplify the sum of the non-sway and sway moments (as obtained, for instance, by a first-order elastic analysis) by the B_2 amplifier, in other words, $M_r = B_2 (M_{nt} + M_{lt})$.

$$B_2 = \frac{1}{1 - \frac{\alpha \sum P_{nt}}{\sum P_c^2}} \geq 1 \quad (6.10.5)$$

And, $\alpha = 1.00$ (LRFD) $\alpha = 1.60$ (ASD)

M_r = required second-order flexural strength using LRFD or ASD load combinations, N-mm

M_{nt} = first-order moment using LRFD or ASD load combinations, assuming there is no lateral translation of the frame, N-mm

M_{lt} = first-order moment using LRFD or ASD load combinations caused by lateral translation of the frame only, N-mm

P_r = required second-order axial strength using LRFD or ASD load combinations, N

P_{nt} = first-order axial force using LRFD or ASD load combinations, assuming there is no lateral translation of the frame, N

$\sum P_{nt}$ = total vertical load supported by the story using LRFD or ASD load combinations, including gravity column loads, N

P_{lt} = first-order axial force using LRFD or ASD load combinations caused by lateral translation of the frame only, N

C_m = a coefficient assuming no lateral translation of the frame whose value shall be taken as follows:

For beam-columns not subject to transverse loading between supports in the plane of bending,

$$C_m = 0.6 - 0.4(M_1/M_2) \quad (6.10.6)$$

Where, M_1 and M_2 , calculated from a first-order analysis, are the smaller and larger moments, respectively, at the ends of that portion of the member unbraced in the plane of bending under consideration. M_1 / M_2 is positive when the member is bent in reverse curvature, negative when bent in single curvature.

For beam-columns subjected to transverse loading between supports, the value of C_m shall be determined either by analysis or conservatively taken as 1.0 for all cases.

P_{e1} = elastic critical buckling resistance of the member in the plane of bending, calculated based on the assumption of zero sidesway, N

$$P_{e1} = \frac{\pi^2 EI}{(K_1 L)^2} \quad (6.10.7)$$

$\sum P_{e2}$ = elastic critical buckling resistance for the story determined by sideway buckling analysis, N

For moment frames, where sideway buckling effective length factors K_2 are determined for the columns, it is permitted to calculate the elastic story sideway buckling resistance as

$$\sum P_{e2} = \sum \frac{\pi^2 EI}{(K_2 L)^2} \quad (6.10.8a)$$

For all types of lateral load resisting systems, it is permitted to use

$$\sum P_{e2} = R_M \frac{\sum HL}{\Delta_H} \quad (6.10.8b)$$

Where,

E = modulus of elasticity of steel = 200 000 MPa

R_m = 1.0 for braced-frame systems;

= 0.85 for moment-frame and combined systems, unless a larger value is justified by analysis

I = moment of inertia in the plane of bending, mm⁴

L = story height, mm

K_1 = effective length factor in the plane of bending, calculated based on the assumption of no lateral translation, set equal to 1.0 unless analysis indicates that a smaller value may be used

K_2 = effective length factor in the plane of bending, calculated based on a sideway buckling analysis

Δ_H = first-order interstory drift due to lateral forces, mm. Where Δ_H varies over the plan area of the structure, Δ_H shall be the average drift weighted in proportion to vertical load or, alternatively, the maximum drift.

$\sum H$ = story shear produced by the lateral forces used to compute Δ_H , N

10.3.2.2 Design requirements

These requirements apply to all types of braced, moment, and combined framing systems. Where the ratio of second-order drift to first-order drift is equal to or less than 1.5, the required strengths of members, connections and other elements shall be determined by one of the methods specified in Sections 10.3.2.2.1 or 10.3.2.2.2, or by the Direct Analysis Method of Sec 10.14. Where the ratio of second-order drift to first-order drift is greater than 1.5, the required strengths shall be determined by the Direct Analysis Method of Sec 10.14.

For the methods specified in Sections 10.3.2.2.1 or 10.3.2.2.2:

Analyses shall be conducted according to the design and loading requirements specified in either Section 10.2.3.3 (LRFD) or Section 10.2.3.4 (ASD).

The structure shall be analyzed using the nominal geometry and the nominal elastic stiffness for all elements.

10.3.2.2.1 Design by second-order analysis

Where required strengths are determined by a second-order analysis:

- (a) The provisions of Sec 10.3.2.1 shall be satisfied.
- (b) For design by ASD, analyses shall be carried out under 1.6 times the *ASD* load combinations and the results shall be divided by 1.6 to obtain the required strengths.
- (c) All gravity-only load combinations shall include a minimum lateral load applied at each level of the structure of $0.002Y_i$, where Y_i is the design gravity load applied at level i . This minimum lateral load shall be considered independently in two orthogonal directions.
- (d) Where the ratio of second-order drift to first-order drift is less than or equal to 1.1, members are permitted to be designed using $K = 1.0$. Otherwise, columns and beam-columns in moment frames shall be designed using a K factor or column buckling stress, F_e , determined from a sideway buckling analysis of the structure. Stiffness reduction adjustment due to column inelasticity is permitted in the determination of the K factor. For braced frames, K for compression members shall be taken as 1.0, unless structural analysis indicates a smaller value may be used.

10.3.2.2.2 Design by first-order analysis

Required strengths are permitted to be determined by a first-order analysis, with all members designed using $K = 1.0$, provided that

- (a) The required compressive strengths of all members whose flexural stiffnesses are considered to contribute to the lateral stability of the structure satisfy the following limitation:

$$\alpha P_r \leq 0.5P_y \quad (6.10.9)$$

Where,

$$\alpha = 1.0(\text{LRFD}) \quad \alpha = 1.6(\text{ASD})$$

P_r = required axial compressive strength under LRFD or ASD load combinations

P_y = member yield strength ($=AF_y$), N.

- (b) All load combinations include an additional lateral load, N_i , applied in combination with other loads at each level of the structure, where

$$N_i = 2.1 \left(\frac{\Delta}{L} \right) Y_i \geq 0.0042Y_i \quad (6.10.10)$$

Y_i = gravity load from the LRFD load combination or 1.6 times the ASD load combination applied at level i , N

Δ/L = the maximum ratio of Δ to L for all stories in the structure

Δ = first-order interstory drift due to the design loads, mm. Where Δ varies over the plan area of the structure, Δ shall be average drift weighted in proportion to vertical load or, alternatively, maximum drift.

L = story height, mm

This additional lateral load shall be considered independently in two orthogonal directions.

- (c) The non-sway amplification of beam-column moments is considered by applying the B1 amplifier of Sec10.3.2.1 to the total member moments.

10.4 Design of Members for Tension

This Section applies to steel members subject to axial tension caused by static forces acting through the centroidal axis.

10.4.1 Slenderness Limitations

The maximum slenderness (KL/r) limit for design of structural members (except cables and hanger rods) in tension shall be 300 unless it is justified by a comprehensive dynamic analysis (including 2nd order effects if applicable) that a higher slenderness ratio is satisfactory.

Here,

L = laterally unbraced length of the member, mm

r = governing radius of gyration, mm

K = the effective length factor determined in accordance with Sec 10.3.2.

10.4.2 Tensile Strength

The design tensile strength, $\phi_t P_n$, and the allowable tensile strength, P_n/Ω_t , of tension members, shall be the lower value obtained according to the limit states of tensile yielding in the gross section and tensile rupture in the net section.

(a) For tensile yielding in the gross section:

$$P_n = F_y A_g \quad (6.10.11)$$

$$\phi_t = 0.90 \text{ (LRFD)} \quad \Omega_t = 1.67 \text{ (ASD)}$$

(b) For tensile rupture in the net section:

$$P_n = F_u A_e \quad (6.10.12)$$

$$\phi_t = 0.75 \text{ (LRFD)} \quad \Omega_t = 2.00 \text{ (ASD)}$$

Where,

A_e = effective net area, mm²

A_g = gross area of member, mm²

F_y = specified minimum yield stress of the type of steel being used, MPa

F_u = specified minimum tensile strength of the type of steel being used, MPa

When members without holes are fully connected by welds, the effective net area used in Eq.6.10.12 shall be as defined in Sec10.4.3. When holes are present in a member with welded end connections, or at the welded connection in the case of plug or slot welds, the effective net area through the holes shall be used in Eq.6.10.12.

10.4.3 Area Determination

10.4.3.1 Gross area

The gross area, A_g , of a member is the total cross-sectional area.

10.4.3.2 Net area

The net area, A_n , of a member is the sum of the products of the thickness and the net width of each element computed as follows:

In computing net area for tension and shear, the width of a bolt hole shall be taken as 2 mm greater than the nominal dimension of the hole.

For a chain of holes extending across a part in any diagonal or zigzag line, the net width of the part shall be obtained by deducting from the gross width the sum of the diameters or slot dimensions as provided in Sec10.10.3.2, of all holes in the chain, and adding, for each gage space in the chain, the quantity $s^2/(4g)$

Where,

s = longitudinal center-to-center spacing (pitch) of any two consecutive holes, mm.

g = transverse center-to-center spacing (gage) between fastener gage lines, mm.

For angles, the gage for holes in opposite adjacent legs shall be the sum of the gages from the back of the angles less the thickness.

For slotted HSS welded to a gusset plate, the net area, A_n , is the gross area minus the product of the thickness and the total width of material that is removed to form the slot.

In determining net area across plug or slot welds, the weld metal shall not be considered as adding to net area.

10.4.3.3 Effective net area

The effective area of tension members shall be determined as follows:

$$A_e = A_n U \quad (6.10.13)$$

Where, U is the shear lag factor as obtained from Table 6.10.2.

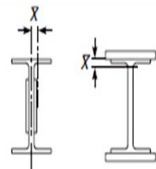
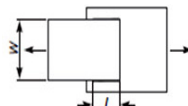
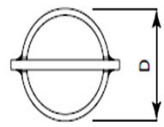
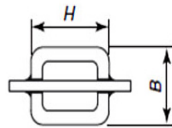
Members such as single angles, double angles and WT sections shall have connections proportioned such that U is equal to or greater than 0.60. Alternatively, a lesser value of U is permitted if these tension members are designed for the effect of eccentricity in accordance with Sections 10.8.1.2 or 10.8.2.

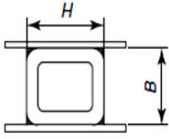
10.4.4 Built-Up Members

For limitations on the longitudinal spacing of connectors between elements in continuous contact consisting of a plate and a shape or two plates, Sec10.10.3.5.

Either perforated cover plates or tie plates without lacing are permitted to be used on the open sides of built-up tension members. Tie plates shall have a length not less than two-thirds the distance between the lines of welds or fasteners connecting them to the components of the member. The thickness of such tie plates shall not be less than one-fiftieth of the distance between these lines. The longitudinal spacing of intermittent welds or fasteners at tie plates shall not exceed 150 mm.

Table 6.10.2: Shear Lag Factors for Connections to Tension Members

Case	Description of Element		Shear Lag Factor, U	Example
1	All tension members where the tension load is transmitted directly to each of cross-sectional elements by fasteners or welds. (except as in Cases 3, 4, 5 and 6)		$U = 1.0$	-
2	All tension members, except plates and HSS, where the tension load is transmitted to some but not all of the cross-sectional elements by fasteners or longitudinal welds (Alternatively, for W, M, S and HP, Case 7 may be used.)		$U = 1 - \bar{X}/l$	
3	All tension members where the tension load is transmitted by transverse welds to some but not all of the cross-sectional elements.		$U = 1.0$ and, $A_n =$ area of the directly connected elements	-
4	Plates where the tension load is transmitted by longitudinal welds only.		$I \geq 2w \dots U = 1.0$ $2w > I \geq 1.5w \dots U = 0.87$ $1.5w > I \geq w \dots U = 0.75$	
5	Round HSS with a single concentric gusset plate		$I \geq 1.3D \dots U = 1.0$ $D \leq I < 1.3D \dots U = 1 - \bar{X} = D/\pi$	
6	Rectangular HSS	with a single concentric gusset plate	$I \geq H \dots U = 1 - \bar{X}/L$ $\bar{X} = \frac{B^2 + 2BH}{4(B + H)}$	

Case	Description of Element		Shear Lag Factor, U	Example
		With two side gusset plates	$I \geq H \dots U = 1 - \bar{X}/L$ $\bar{X} = \frac{B^2}{4(B + H)}$	
7	W, M, S or HP Shapes or Tees cut from these shapes. (If U is calculated per Case 2, the larger value is permitted to be used)	With flange connected with 3 or more fasteners per line in direction of loading	$b_f \geq 2/3d \dots U = 0.90$ $b_f \leq 2/3d \dots U = 0.85$	-
		With web connected with 4 or more fasteners per line in the direction of loading	$U = 0.70$	-
8	Single angles (If U is calculated per Case 2, the larger value is permitted to be used)	With 4 or more fasteners per line in direction of loading	$U = 0.80$	-
		With 2 or 3 fasteners per line in the direction of loading	$U = 0.60$	-
I = Length of connection, mm; w = plate width, mm; \bar{X} = connection eccentricity, mm; B = overall width of rectangular HSS member, measured 90° to the plane of the connection, mm; H = overall height of rectangular HSS member, measured in the plane of the connection, mm				

10.4.5 Pin-Connected Members

10.4.5.1 Tensile strength

The design tensile strength, ϕP_n and the allowable tensile strength, P_n/Ω_t , of pin-connected members, shall be the lower value obtained according to the limit states of tensile rupture, shear rupture, bearing, and yielding.

- (a) For tensile rupture on the net effective area:

$$P_{\eta} = 2tb_{\text{eff}}F_u \quad (6.10.14)$$

$$\phi_t = 0.75 \text{ (LRFD)} \quad \Omega_t = 2.00 \text{ (ASD)}$$

- (b) For shear rupture on the effective area:

$$P_{\eta} = 0.6F_uA_{sf} \quad (6.10.15)$$

$$\phi_{sf} = 0.75 \text{ (LRFD)} \quad \Omega_{sf} = 2.00 \text{ (ASD)}$$

Where,

$$A_{sf} = 2t(a+d/2), \text{ mm}^2$$

a = shortest distance from edge of the pin hole to the edge of the member measured parallel to the direction of the force, mm

$b_{\text{eff}} = 2t + 16$, mm but not more than the actual distance from the edge of the hole to the edge of the part measured in the direction normal to the applied force

d = pin diameter, mm

t = thickness of plate, mm

- (c) For bearing on the projected area of the pin, see Sec 10.10.7.

- (d) For yielding on the gross-section, use Eq.6.10.11.

10.4.5.2 Dimensional requirements $1.33b_{\text{eff}}$

The pin hole shall be located midway between the edges of the member in the direction normal to the applied force. When the pin is expected to provide for relative movement between connected parts while under full load, the diameter of the pin hole shall not be more than 1 mm greater than the diameter of the pin.

The width of the plate at the pin hole shall not be less than $(2b_{\text{eff}} + d)$ and the minimum extension, a , beyond the bearing end of the pin hole, parallel to the axis of the member, shall not be less than $1.33b_{\text{eff}}$

The corners beyond the pin hole are permitted to be cut at 45° to the axis of the member, provided the *net area* beyond the pin hole, on a plane perpendicular to the cut, is not less than that required beyond the pin hole parallel to the axis of the member.

10.4.6 Eyebars

10.4.6.1 Tensile strength

The available tensile strength of eyebars shall be determined in accordance with Sec 10.4.2, with A_g taken as the cross-sectional area of the body.

For calculation purposes, the width of the body of the eyebars shall not exceed eight times its thickness.

10.4.6.2 Dimensional requirements

Eyebars shall be of uniform thickness, without reinforcement at the pin holes, and have circular heads with the periphery concentric with the pin hole.

The radius of transition between the circular head and the eyebar body shall not be less than the head diameter.

The pin diameter shall not be less than seven-eighths times the eyebar body width, and the pin hole diameter shall not be more than 1 mm greater than the pin diameter.

For steels having F_y greater than 485 MPa, the hole diameter shall not exceed five times the plate thickness and the width of the eyebar body shall be reduced accordingly.

A thickness of less than 13 mm is permissible only if external nuts are provided to tighten pin plates and filler plates into snug contact. The width from hole edge to plate edge perpendicular to the direction of applied load shall be greater than two-thirds and, for the purpose of calculation, not more than three-fourths times the eyebar body width.

10.5 Design of Members for Compression

This Section addresses members subject to axial compression through the centroidal axis.

10.5.1 General Provisions

The design compressive strength, $\phi_c P_n$, and the allowable compressive strength, P_n/Ω_c , are determined as follows:

The nominal compressive strength, P_n shall be the lowest value obtained according to the limit states of flexural buckling, torsional buckling and flexural-torsional buckling.

For doubly symmetric and singly symmetric members the limit state of flexural buckling is applicable.

For singly symmetric and unsymmetric members, and certain doubly symmetric members, such as cruciform or built-up columns, the limit states of torsional or flexural-torsional buckling are also applicable.

$$\phi_c = 0.90 \text{ (LRFD)} \quad \Omega_c = 1.67 \text{ (ASD)}$$

10.5.2 Slenderness Limitations and Effective Length

The effective length factor, K for calculation of column slenderness, KL/r , shall be determined in accordance with Sec 10.3.

Where,

L = laterally unbraced length of the member, mm

r = governing radius of gyration, mm

K = the effective length factor determined in accordance with Sec 10.3.2.

The maximum limit of slenderness, KL/r , for compression members shall be 150 unless a comprehensive analysis including second order effects (including dynamic effects if any) shows that a higher value is justified.

10.5.3 Compressive Strength for Flexural Buckling of Members without Slender Elements

This Section applies to compression members with compact and non-compact sections, as defined in Sec 10.2.4, for uniformly compressed elements.

The nominal compressive strength, P_n , shall be determined based on the limit state of flexural buckling.

$$P_n = F_{cr}A_g \quad (6.10.16)$$

The flexural buckling stress, F_{cr} , is determined as follows:

(a) When $\frac{KL}{r} \leq 4.71 \sqrt{\frac{E}{F_y}}$ (or $F_e \geq 0.44 F_y$)

$$F_{cr} = \left[0.658 \frac{F_y}{F_e} \right] F_y \quad (6.10.17)$$

(b) When $\frac{KL}{r} > 4.71 \sqrt{\frac{E}{F_y}}$ (or $F_e < 0.44 F_y$)

$$F_{cr} = 0.877 F_e \quad (6.10.18)$$

Where,

F_e = elastic critical buckling stress determined according to Eq.6.10.19, Sec 10.5.4, or the provisions of Sec 10.3.2, as applicable,

$$F_e = \frac{\pi^2 E}{\left(\frac{KL}{r}\right)^2} \quad (6.10.19)$$

10.5.4 Compressive Strength for Torsional and Flexural-Torsional Buckling of Members without Slender Elements

This section applies to singly symmetric and unsymmetric members, and certain doubly symmetric members, such as cruciform or built-up columns with compact and non compact sections, as defined in Sec 10.2.4 for uniformly compressed elements. These provisions are not required for single angles, which are covered in Sec 10.5.5.

The nominal compressive strength, P_n , shall be determined based on the limit states of flexural-torsional and torsional buckling, as follows:

$$P_n = F_{cr} A_g \quad (6.10.20)$$

For double-angle and tee-shaped compression members:

$$F_{cr} = \left(\frac{F_{cry} + F_{crz}}{2H} \right) \left[1 - \sqrt{1 - \frac{4F_{cry}F_{crz}H}{(F_{cry} + F_{crz})^2}} \right] \quad (6.10.21)$$

Where,

F_{cry} is taken as F_{cr} from Eq.6.10.17 or 6.10.18, for flexural buckling about the y-axis of symmetry and $\frac{KL}{r} = \frac{KL}{r_y}$, and

$$F_{crz} = \frac{GJ}{A_g \bar{r}_0^2} \quad (6.10.22)$$

For all other cases, F_{cr} shall be determined according to Eq.6.10.17 or 6.10.18, using the torsional or flexural-torsional elastic buckling stress, F_e determined as follows:

For doubly symmetric members:

$$F_e = \left[\frac{\pi^2 EC_w}{(K_z L)^2} + GJ \right] \frac{1}{I_x + I_y} \quad (6.10.23)$$

For singly symmetric members where y is the axis of symmetry:

$$F_e = \left(\frac{F_{ey} + F_{ez}}{2H} \right) \left[1 - \sqrt{1 - \frac{4F_{ey}F_{ez}H}{(F_{ey} + F_{ez})^2}} \right] \quad (6.10.24)$$

For unsymmetric members, F_e is the lowest root of the cubic equation:

$$(F_e - F_{ex})(F_e - F_{ey})(F_e - F_{ez}) - F_e^2(F_e - F_{ey})\left(\frac{x_0}{\bar{r}_0}\right)^2 - F_e^2(F_e - F_{ex})\left(\frac{y_0}{\bar{r}_0}\right)^2 = 0 \quad (6.10.25)$$

Where,

A_g = gross area of member, mm²

C_w = warping constant, mm⁶

$$\bar{r}_0^2 = x_0^2 + y_0^2 + \frac{I_x + I_y}{A_g} \quad (6.10.26)$$

$$H = 1 - \frac{x_0^2 + y_0^2}{\bar{r}_0^2} \quad (6.10.27)$$

$$F_{ex} = \frac{\pi^2 E}{\left(\frac{K_x L}{r_x}\right)^2} \quad (6.10.28)$$

$$F_{ey} = \frac{\pi^2 E}{\left(\frac{K_y L}{r_y}\right)^2} \quad (6.10.29)$$

$$F_{ez} = \left(\frac{\pi^2 E C_w}{(K_z L)^2} + GJ\right) \frac{1}{A_g \bar{r}_0^2} \quad (6.10.30)$$

G = shear modulus of elasticity of steel = 77200 MPa

I_x, I_y = moment of inertia about the principal axes, mm⁴

J = torsional constant, mm⁴

K_z = effective length factor for torsional buckling

x_0, y_0 = coordinates of shear center with respect to the centroid, mm

\bar{r}_0 = polar radius of gyration about the shear center, mm

r_y = radius of gyration about y-axis, mm

10.5.5 Single Angle Compression Members

The nominal compressive strength, P_n , of single angle members shall be determined in accordance with Sec 10.5.3 or Sec 10.5.7, as appropriate, for axially loaded members, as well as those subject to the slenderness modification of Sec 10.5.5(a) or 10.5.5(b), provided the members meet the criteria imposed.

The effects of eccentricity on single angle members are permitted to be neglected when the members are evaluated as axially loaded compression members using one of the effective slenderness ratios specified below, provided that: (1) members are loaded at the ends in compression through the same one leg; (2) members are attached by welding or by minimum two-bolt connections; and (3) there are no intermediate transverse loads.

- (a) For equal-leg angles or unequal-leg angles connected through the longer leg that are individual members or are web members of planar trusses with adjacent web members attached to the same side of the gusset plate or chord:

(i) When $0 \leq \frac{L}{r_x} \leq 80$

$$\frac{KL}{r} = 72 + \frac{0.75L}{r_x} \quad (6.10.31)$$

(ii) When $\frac{L}{r_x} > 80$

$$\frac{KL}{r} = 32 + \frac{1.25L}{r_x} \leq 200 \quad (6.10.32)$$

For unequal-leg angles with leg length ratios less than 1.7 and connected through the shorter leg, KL/r from Eq.6.10.31 and Eq.6.10.32 shall be increased by adding $4[(b_l/b_s)^2 - 1]$, but KL/r of the members shall not be less than $0.95L/r_z$.

- (b) For equal-leg angles or unequal-leg angles connected through the longer leg that are web members of box or space trusses with adjacent web members attached to the same side of the gusset plate or chord:

(i) When $0 \leq \frac{L}{r_x} \leq 75$

$$\frac{KL}{r} = 60 + \frac{0.8L}{r_x} \quad (6.10.33a)$$

(ii) When $\frac{L}{r_x} > 75$

$$\frac{KL}{r} = 45 + \frac{L}{r_x} \leq 200 \quad (6.10.33b)$$

For unequal-leg angles with leg length ratios less than 1.7 and connected through the shorter leg, KL/r from Eq.6.10.33a and 6.10.33b shall be increased by adding $6[(b_l/b_s)^2 - 1]$, but KL/r of the members shall not be less than $0.82L/r_z$.

Where,

L = length of member between work points at truss chord centerlines, mm

b_l = longer leg of angle, mm

b_s = shorter leg of angle, mm

r_x = radius of gyration about geometric axis parallel to connected leg, mm

r_z = radius of gyration for the minor principal axis, mm

- (c) Single angle members with different end conditions from those described in Sections 10.5.5(a) or (b), with leg length ratios greater than 1.7, or with transverse loading shall be evaluated for combined axial load and flexure using the provisions of Sec 10.8. End connection to different legs on each end or to both legs, the use of single bolts or the attachment of adjacent web members to opposite sides of the gusset plate or chord shall constitute different end conditions requiring the use of Sec 10.8 provisions.

10.5.6 Built-up Members

10.5.6.1 Compressive Strength

- (a) The nominal compressive strength of built-up members composed of two or more shapes that are interconnected by bolts or welds shall be determined in accordance with Sections 10.5.3, 10.5.4, or 10.5.7 subject to the following modification. In lieu of more accurate analysis, if the buckling mode involves relative deformations that produce shear forces in the connectors between individual shapes, KL/r is replaced by $(KL/r)_m$ determined as follows:

- (i) For intermediate connectors that are snug-tight bolted:

$$\left(\frac{KL}{r}\right)_m = \sqrt{\left(\frac{KL}{r}\right)_0^2 + \left(\frac{a}{r_i}\right)^2} \quad (6.10.34)$$

- (ii) For intermediate connectors that are welded or pretensioned bolted:

$$\left(\frac{KL}{r}\right)_m = \sqrt{\left(\frac{KL}{r}\right)_0^2 + 0.82 \frac{\alpha^2}{(1+\alpha^2)} \left(\frac{a}{r_{ib}}\right)^2} \quad (6.10.35)$$

Where,

$\left(\frac{KL}{r}\right)_m$ = modified column slenderness of built-up member

$\left(\frac{KL}{r}\right)_0$ = column slenderness of built-up member acting as a unit in the buckling direction being considered

a = distance between connectors, mm

r_i = minimum radius of gyration of individual component, mm

r_{ib} = radius of gyration of individual component relative to its centroidal axis parallel to member axis of buckling, mm

α = separation ratio = $h/2r_{ib}$

H = distance between centroids of individual components perpendicular to the member axis of buckling, mm

- (b) The nominal compressive strength of built-up members composed of two or more shapes or plates with at least one open side interconnected by perforated cover plates or lacing with tie plates shall be determined in accordance with Sections 10.5.3, 10.5.4, or 10.5.7 subject to modification given in Sec 10.5.6.1 (a).

10.5.6.2 Dimensional requirements

Individual components of compression members composed of two or more shapes shall be connected to one another at intervals, a , such that the effective slenderness ratio k_a/r_i of each of the component shapes, between the fasteners, does not exceed three-fourths times the governing slenderness ratio of the built-up member. The least radius of gyration, r_i , shall be used in computing the slenderness ratio of each component part. The end connection shall be welded or pre-tensioned bolted with Class A or B faying surfaces.

At the ends of built-up compression members bearing on base plates or milled surfaces, all components in contact with one another shall be connected by a weld having a length not less than the maximum width of the member or by bolts spaced longitudinally not more than four diameters apart for a distance equal to $1\frac{1}{2}$ times the maximum width of the member.

Along the length of built-up compression members between the end connections required above, longitudinal spacing for intermittent welds or bolts shall be adequate to provide for the transfer of the required forces. For limitations on the longitudinal spacing of fasteners between elements in continuous contact consisting of a plate and a shape or two plates, see Sec 10.10.3.5. Where a component of a built-up compression member consists of an outside plate, the maximum spacing shall not exceed the thickness of the thinner outside plate times $0.75\sqrt{E/F_y}$, nor 305 mm, when intermittent welds are provided along the edges of the components or when fasteners are provided on all gage lines at each section. When fasteners are staggered, the maximum spacing on each gage line shall not exceed the thickness of thinner outside plate times $1.12\sqrt{E/F_y}$ nor 460 mm.

Open sides of compression members built up from plates or shapes shall be provided with continuous cover plates perforated with a succession of access holes. The unsupported width of such plates at access holes, as defined in Sec 10.2.4, is assumed to contribute to the available strength provided the following requirements are met:

- (1) The width-thickness ratio shall conform to the limitations of Sec 10.2.4.
- (2) The ratio of length (in direction of stress) to width of hole shall not exceed two.
- (3) The clear distance between holes in the direction of stress shall be not less than the transverse distance between nearest lines of connecting fasteners or welds.
- (4) The periphery of the holes at all points shall have a minimum radius of 38 mm.

As an alternative to perforated cover plates, lacing with tie plates is permitted at each end and at intermediate points if the lacing is interrupted. Tie plates shall be as near the ends as practicable. In members providing available strength, the end tie plates shall have a

length of not less than the distance between the lines of fasteners or welds connecting them to the components of the member. Intermediate tie plates shall have a length not less than one-half of this distance. The thickness of tie plates shall be not less than one-fiftieth of the distance between lines of welds or fasteners connecting them to the segments of the members. In welded construction, the welding on each line connecting a tie plate shall total not less than one-third the length of the plate. In bolted construction, the spacing in the direction of stress in tie plates shall be not more than six diameters and the tie plates shall be connected to each segment by at least three fasteners.

Lacing, including flat bars, angles, channels, or other shapes employed as lacing, shall be so spaced that the L/r ratio of the flange included between their connections shall not exceed three-fourths times the governing slenderness ratio for the member as a whole. Lacing shall be proportioned to provide a shearing strength normal to the axis of the member equal to 2 percent of the available compressive strength of the member. The L/r ratio for lacing bars arranged in single systems shall not exceed 140. For double lacing this ratio shall not exceed 200. Double lacing bars shall be joined at the intersections. For lacing bars in compression, L is permitted to be taken as the unsupported length of the lacing bar between welds or fasteners connecting it to the components of the built-up member for single lacing, and 70 percent of that distance for double lacing.

For additional spacing requirements, see Sec 10.10.3.5.

10.5.7 Members with Slender Elements

This Section applies to compression members with slender sections, as defined in Sec 10.2.4 for uniformly compressed elements.

The nominal compressive strength, P_n , shall be determined based on the limit states of flexural, torsional and flexural-torsional buckling.

$$P_n = F_{cr} A_g \quad (6.10.36)$$

$$\text{When } \frac{KL}{r} \leq 4.71 \sqrt{\frac{E}{QF_y}} \quad (\text{or } F_e \geq 0.44 QF_y)$$

$$F_{cr} = Q \left[0.658 \frac{QF_y}{F_e} \right] F_y \quad (6.10.37)$$

$$\text{When } \frac{KL}{r} > 4.71 \sqrt{\frac{E}{QF_y}} \quad (\text{or } F_e < 0.44 QF_y)$$

$$F_{cr} = 0.877 F_e \quad (6.10.38)$$

Where,

F_e = elastic critical buckling stress, calculated using Eq.6.10.19 and 6.10.23 for doubly symmetric members, Eq.6.10.19 and 6.10.24 for singly symmetric members, and Eq.6.10.25 for unsymmetric members, except for single angles where F_e is calculated using Eq.6.10.19.

$Q = 1.0$ for members with compact and noncompact sections, as defined in Sec 10.2.4, for uniformly compressed elements.

$= Q_s Q_a$ for members with slender-element sections, as defined in Sec 10.2.4, for uniformly compressed elements.

10.5.7.1 Slender unstiffened elements, Q_s

The reduction factor Q_s for slender unstiffened elements is defined as follows:

- (a) For flanges, angles, and plates projecting from rolled columns or other compression members:

$$\text{When } \frac{b}{t} \leq 0.56 \sqrt{\frac{E}{F_y}}$$

$$Q_s = 1.0 \quad (6.10.39)$$

$$\text{When } 0.56 \sqrt{E/F_y} < b/t < 1.03 \sqrt{E/F_y}$$

$$Q_s = 1.415 - 0.74 \left(\frac{b}{t}\right) \sqrt{\frac{F_y}{E}} \quad (6.10.40)$$

$$\text{When } b/t \geq 1.03 \sqrt{E/F_y}$$

$$Q_s = \frac{0.69E}{F_y \left(\frac{b}{t}\right)^2} \quad (6.10.41)$$

- (b) For flanges, angles, and plates projecting from built-up columns or other compression members:

$$\text{When } \frac{b}{t} \leq 0.64 \sqrt{\frac{Ek_c}{F_y}}$$

$$Q_s = 1.0 \quad (6.10.42)$$

When $0.64\sqrt{\frac{Ek_c}{F_y}} < b/t \leq 1.17\sqrt{\frac{Ek_c}{F_y}}$

$$Q_s = 1.415 - 0.65\left(\frac{b}{t}\right)\sqrt{\frac{F_y}{Ek_c}} \quad (6.10.43)$$

When $\frac{b}{t} > 1.17\sqrt{\frac{Ek_c}{F_y}}$

$$Q_s = \frac{0.90Ek_c}{F_y\left(\frac{b}{t}\right)^2} \quad (6.10.44)$$

Where, $k_c = \frac{4}{\sqrt{h/t_w}}$, and shall not be taken less than 0.35 nor greater than 0.76 for calculation purposes.

(c) For single angles

When $\frac{b}{t} \leq 0.45\sqrt{\frac{E}{F_y}}$

$$Q_s = 1.0 \quad (6.10.45)$$

When $0.45\sqrt{E/F_y} < b/t \leq 0.91\sqrt{E/F_y}$

$$Q_s = 1.34 - 0.76\left(\frac{b}{t}\right)\sqrt{\frac{F_y}{E}} \quad (6.10.46)$$

When $b/t > 0.91\sqrt{E/F_y}$

$$Q_s = \frac{0.53E}{F_y\left(\frac{b}{t}\right)^2} \quad (6.10.47)$$

Where, b = full width of longest angle leg, mm

(d) For stems of tees

When $\frac{d}{t} \leq 0.75\sqrt{\frac{E}{F_y}}$

$$Q_s = 1.0 \quad (6.10.48)$$

When $0.75 \sqrt{\frac{E}{F_y}} < d/t \leq 1.03 \sqrt{\frac{E}{F_y}}$

$$Q_s = 1.908 - 1.22 \left(\frac{d}{t}\right) \sqrt{\frac{F_y}{E}} \quad (6.10.49)$$

When $d/t > 1.03 \sqrt{\frac{E}{F_y}}$

$$Q_s = \frac{0.69E}{F_y \left(\frac{d}{t}\right)^2} \quad (6.10.50)$$

Where,

b = width of unstiffened compression element, as defined in Sec 10.2.4, mm

d = the full nominal depth of tee, mm

t = thickness of element, mm

10.5.7.2 Slender unstiffened elements, Q_s

The reduction factor, Q_a , for slender stiffened elements is defined as follows:

$$Q_a = \frac{A_{eff}}{A} \quad (6.10.51)$$

A = total cross-sectional area of member, mm²

A_{eff} = summation of effective areas of the cross section based on the reduced effective width, b_e , mm².

The reduced effective width, b_e , is determined as follows:

- (a) For uniformly compressed slender elements, with $\frac{b}{t} \geq 1.49 \sqrt{\frac{E}{f}}$, except flanges of square and rectangular sections of uniform thickness:

$$b_e = 1.92t \sqrt{\frac{E}{f}} \left[1 - \frac{0.34}{(b/t)} \sqrt{\frac{E}{f}} \right] \leq b \quad (6.10.52)$$

Where, f is taken as F_{cr} with F_{cr} calculated based on $Q = 1.0$.

(b) For flanges of square and rectangular slender-element sections of uniform thickness

$$\text{with } \frac{b}{t} \geq 1.40 \sqrt{\frac{E}{f}}$$

$$b_e = 1.92t \sqrt{\frac{E}{f}} \left[1 - \frac{0.38}{(b/t)} \sqrt{\frac{E}{f}} \right] \leq b \quad (6.10.53)$$

Where $f = P_n/A_{eff}$

(c) For axially-loaded circular sections:

$$\text{When } 0.11 \frac{E}{F_y} < \frac{D}{t} < 0.45 \frac{E}{F_y}$$

$$Q = Q_a = \frac{0.038E}{F_y(D/t)} + \frac{2}{3} \quad (6.10.54)$$

Where,

D = outside diameter, mm

t = wall thickness, mm

10.6 Design of Members for Flexure

This Section applies to members subject to simple bending about one principal axis. For simple bending, the member is loaded in a plane parallel to a principal axis that passes through the shear center or is restrained against twisting at load points and supports. The general provisions are provided in Sec 10.6.1. Various Section properties of members are provided in Table 6.10.3.

10.6.1 General Provisions

The design flexural strength, $\phi_b M_n$, and the allowable flexural strength, M_n/Ω_b , shall be determined as follows:

(a) For all provisions in this Sec 10.6

$$\phi_b = 0.90 \text{ (LRFD)} \quad \Omega_b = 1.67 \text{ (ASD)}$$

And, the nominal flexural strength, M_n , shall be determined according to Sections 10.6.2 to 10.6.12.

- (b) The provisions in this Chapter are based on the assumption that points of support for beams and girders are restrained against rotation about their longitudinal axis.

The following terms are common to the Equations in this Chapter except where noted:

C_b = lateral-torsional buckling modification factor for non-uniform moment diagrams when both ends of the unsupported segment are braced

$$C_b = \frac{12.5M_{max}}{2.5M_{max}+3M_A+4M_B+3M_C} R_m \leq 3.0 \quad (6.10.55)$$

Where,

M_{max} = absolute value of maximum moment in the unbraced segment, N-mm

M_A = absolute value of moment at quarter point of the unbraced segment, N-mm

M_B = absolute value of moment at centerline of the unbraced segment, N-mm

M_C = absolute value of moment at three-quarter point of the unbraced segment, N-mm

R_m = cross-section monosymmetry parameter

= 1.0, doubly symmetric members

= 1.0, singly symmetric members subjected to single curvature bending

= $0.5 + 2 \left(\frac{I_{yc}}{I_y} \right)^2$, singly symmetric members subjected to reverse curvature bending

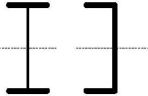

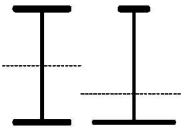
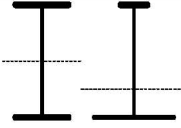
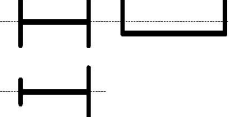


I_y = moment of inertia about the principal y-axis, mm⁴




I_{yc} = moment of inertia about y-axis referred to the compression flange, or if reverse curvature bending, referred to the smaller flange, mm⁴

In singly symmetric members subjected to reverse curvature bending, the lateral-torsional buckling strength shall be checked for both flanges. The available flexural strength shall be greater than or equal to the maximum required moment causing compression within the flange under consideration.

C_b is permitted to be conservatively taken as 1.0 for all cases. For cantilevers or overhangs where the free end is unbraced, $C_b = 1.0$.

Table 6.10.3: Section Types and Selection Table for the Application of Sub-sections of Sec 10.6

Sub-Section in this provision	Cross Section	Flange Slenderness	Web Slenderness	Limit States
10.6.2		C	C	Y,LTB
10.6.3		NC, S	C	LTB, FLB
10.6.4		C, NC, S	C, NC	Y, LTB, FLB, TFY
10.6.5		C, NC, S	S	Y, LTB, FLB, TFY
10.6.6		C, NC, S	N/A	Y, FLB
10.6.7		C, NC, S	C, NC	Y, FLB, WLB
10.6.8		N/A	N/A	Y, LB

Sub-Section in this provision	Cross Section	Flange Slenderness	Web Slenderness	Limit States
10.6.9		C, NC, S	N/A	Y, LTB, FLB
10.6.10		N/A	N/A	Y, LTB, LLB
10.6.11		N/A	N/A	Y, LTB
10.6.12	Unsymmetrical shapes	N/A	N/A	All limit states

Y = yielding, LTB = lateral-torsional buckling, FLB = flange local buckling, WLB = web local buckling, TFY = tension flange yielding, LLB = leg local buckling, LB = local buckling, C = compact, NC = noncompact, S = slender

10.6.2 Doubly Symmetric Compact I-Shaped Members and Channels Bent about their Major Axis

This Section applies to doubly symmetric I-shaped members and channels bent about their major axis, having compact webs and compact flanges as defined in Sec10.2.4.

The nominal flexural strength, M_n , shall be the lower value obtained according to the limit states of yielding (plastic moment) and lateral-torsional buckling.

10.6.2.1 Yielding

$$M_n = M_p = F_y Z_x \quad (6.10.56)$$

Where,

F_y = specified minimum yield stress of the type of steel being used, MPa

Z_x = plastic section modulus about the x-axis, mm³

10.6.2.2 Lateral –torsional buckling

(a) When $L_b \leq L_p$, the limit state of lateral-torsional buckling does not apply.

(b) When $L_p < L_b \leq L_r$

$$M_n = C_b \left[M_p - (M_p - 0.7F_y S_x) \left(\frac{L_b - L_p}{L_r - L_p} \right) \right] \leq M_p \quad (6.10.57)$$

(c) When $L_b > L_r$

$$M_n = F_{cr} S_x \leq M_p \quad (6.10.58)$$

Where,

L_b = length between points that are either braced against lateral displacement of compression flange or braced against twist of the cross section, mm

$$F_{cr} = \frac{C_b \pi^2 E}{\left(\frac{L_b}{r_{ts}} \right)^2} \sqrt{1 + 0.078 \frac{Jc}{S_x h_o} \left(\frac{L_b}{r_{ts}} \right)^2} \quad (6.10.59)$$

And where,

E = modulus of elasticity of steel = 200000 MPa

J = torsional constant, mm⁴

S_x = elastic section modulus taken about the x-axis, mm³

The limiting lengths L_p and L_r are determined as follows:

$$L_p = 1.76 r_y \sqrt{\frac{E}{F_y}} \quad (6.10.60)$$

$$L_r = 1.95 r_{ts} \frac{E}{0.7 F_y} \sqrt{\frac{Jc}{S_x h_o} \sqrt{1 + \sqrt{1 + 6.76 \left(\frac{0.7 F_y S_x h_o}{E Jc} \right)^2}} } \quad (6.10.61)$$

Where,

$$r_{ts}^2 = \frac{\sqrt{I_y C_w}}{S_x} \quad (6.10.62)$$

And,

$$\text{For a doubly symmetric I-shape: } c = 1 \quad (6.10.63a)$$

$$\text{For a channel: } c = \frac{h_o}{2} \sqrt{\frac{I_y}{C_w}} \quad (6.10.63b)$$

Where, h_o = distance between the flange centroids, mm

10.6.3 Doubly Symmetric I-Shaped Members with Compact Webs and Noncompact or Slender Flanges Bent about their Major Axis

This Section applies to doubly symmetric I-shaped members bent about their major axis having compact webs and noncompact or slender flanges as defined in Sec10.2.4.

The nominal flexural strength, M_n , shall be the lower value obtained according to the limit states of lateral-torsional buckling and compression flange local buckling.

10.6.3.1 Lateral –torsional buckling

For lateral-torsional buckling, the provisions of Sec 10.6.2.2 shall apply.

10.6.3.2 Compression flange local buckling

(a) For sections with noncompact flanges

$$M_n = \left[M_p - (M_p - 0.7F_y S_x) \left(\frac{\lambda - \lambda_{pf}}{\lambda_{rf} - \lambda_{pf}} \right) \right] \quad (6.10.64)$$

(b) For sections with slender flanges

$$M_n = \frac{0.9Ek_c S_x}{\lambda^2} \quad (6.10.65)$$

Where,

$$\lambda = \frac{b_f}{2t_f}$$

$\lambda_{pf} = \lambda_p$ is the limiting slenderness for a compact flange, Table 6.10.1

$\lambda_{rf} = \lambda_r$ is the limiting slenderness for a noncompact flange, Table 6.10.1

$k_c = \frac{4}{\sqrt{h/t_w}}$ and shall not be taken less than 0.35 nor greater than 0.76 for calculation purposes

10.6.4 Other I-Shaped Members with Compact or Noncompact Webs Bent about their Major Axis

This Section applies to: (a) doubly symmetric I-shaped members bent about their major axis with noncompact webs; and (b) singly symmetric I-shaped members with webs attached to the mid-width of the flanges, bent about their major axis, with compact or noncompact webs, as defined in Section 10.2.4.

The nominal flexural strength, M_n , shall be the lowest value obtained according to the limit states of compression flange yielding, lateral-torsional buckling, compression flange local buckling and tension flange yielding.

10.6.4.1 Compression flange yielding

$$M_n = R_{pc}M_{yc} = R_{pc}F_yS_{xc} \quad (6.10.66)$$

10.6.4.2 Lateral-torsional buckling

(a) When $L_b \leq L_p$, the limit state of lateral-torsional buckling does not apply.

(b) When $L_p < L_b \leq L_r$

$$M_n = C_b \left[R_{pc}M_{yc} - (R_{pc}M_{yc} - F_L S_{xc}) \left(\frac{L_b - L_p}{L_r - L_p} \right) \right] \leq R_{pc}M_{yc} \quad (6.10.67)$$

(c) When $L_b > L_r$

$$M_n = F_{cr}S_{xc} \leq R_{pc}M_{yc} \quad (6.10.68)$$

Where

$$M_{yc} = F_y S_{xc} \quad (6.10.69)$$

$$F_{cr} = \frac{C_b \pi^2 E}{\left(\frac{L_b}{r_t} \right)^2} \sqrt{1 + 0.078 \frac{J}{S_{xc} h_0} \left(\frac{L_b}{r_t} \right)^2} \quad (6.10.70)$$

For, $\frac{I_{yc}}{I_y} \leq 0.23$, J shall be taken as zero.

The stress, F_L , is determined as follows:

(i) For $\frac{S_{xt}}{S_{xc}} \geq 0.7$

$$F_L = 0.7F_y \quad (6.10.71a)$$

(ii) For $\frac{S_{xt}}{S_{xc}} < 0.7$

$$F_L = F_y \frac{S_{xt}}{S_{xc}} \geq 0.5F_y \quad (6.10.71b)$$

The limiting laterally unbraced length for the limit state of yielding, L_p is,

$$L_p = 1.1r_t \sqrt{\frac{E}{F_y}} \quad (6.10.72)$$

The limiting unbraced length for the limit state of inelastic lateral-torsional buckling, L_r , is

$$L_r = 1.95r_t \frac{E}{F_L} \sqrt{\frac{J}{S_{xc}h_0}} \sqrt{1 + \sqrt{1 + 6.76 \left(\frac{F_L S_{xc} h_0}{E J} \right)^2}} \quad (6.10.73)$$

The web plastification factor, R_{pc} , is determined as follows:

$$(i) \text{ For } \frac{h_c}{t_w} \leq \lambda_{pw}$$

$$R_{pc} = \frac{M_p}{M_{yc}} \quad (6.10.74a)$$

$$(ii) \text{ For } \frac{h_c}{t_w} > \lambda_{pw}$$

$$R_{pc} = \left[\frac{M_p}{M_{yc}} - \left(\frac{M_p}{M_{yc}} - 1 \right) \left(\frac{\lambda - \lambda_{pw}}{\lambda_{rw} - \lambda_{pw}} \right) \right] \leq \frac{M_p}{M_{yc}} \quad (6.10.74b)$$

Where

$$M_p = Z_x F_y \leq 1.6 S_{xc} F_y$$

S_{xc}, S_{xt} = elastic section modulus referred to tension and compression flanges, respectively, mm^3

$$\lambda = \frac{h_c}{t_w}$$

$\lambda_{pw} = \lambda_p$ limiting slenderness for a compact web, Table 6.10.1

$\lambda_{rw} = \lambda_r$ limiting slenderness for a noncompact web, Table 6.10.1

The effective radius of gyration for lateral-torsional buckling, r_t , is determined as follows:

- (i) For I-shapes with a rectangular compression flange:

$$r_t = \frac{b_{fc}}{\sqrt{12\left(\frac{h_0}{d} + \frac{1}{6}a_w\frac{h^2}{h_0d}\right)}} \quad (6.10.75)$$

Where,

$$a_w = \frac{h_c t_w}{b_{fc} t_{fc}} \quad (6.10.76)$$

b_{fc} = compression flange width, mm

t_{fc} = compression flange thickness, mm

- (ii) For I-shapes with channel caps or cover plates attached to the compression flange:

r_t = radius of gyration of the flange components in flexural compression plus one-third of the web area in compression due to application of major axis bending moment alone, mm

a_w = the ratio of two times the web area in compression due to application of major axis bending moment alone to the area of the compression flange components.

10.6.4.3 Compression flange local buckling

- (a) For sections with compact flanges, the limit state of local buckling does not apply.

- (b) For sections with noncompact flanges

$$M_n = \left[R_{pc} M_{yc} - (R_{pc} M_{yc} - F_L S_{xc}) \left(\frac{\lambda - \lambda_{pf}}{\lambda_{rf} - \lambda_{pf}} \right) \right] \quad (6.10.77)$$

- (c) For sections with slender flanges

$$M_n = \frac{0.9 E k_c S_{xc}}{\lambda^2} \quad (6.10.78)$$

Where,

F_L is defined in Eq. 6.10.71a and Eq. 6.10.72b

R_{pc} = is the web plastification factor, determined by Eq. 6.10.74

$k_c = \frac{4}{\sqrt{h/t_w}}$ and shall not be taken less than 0.35 nor greater than 0.76 for

calculation purposes

$$\lambda = \frac{b_{fc}}{2t_{fc}}$$

$\lambda_{pf} = \lambda_p$ limiting slenderness for a compact flange, Table 6.10.1

$\lambda_{rf} = \lambda_r$ limiting slenderness for a noncompact flange, Table 6.10.1

10.6.4.4 Tension flange yielding

(a) When $S_{xt} \geq S_{xc}$, the limit state of tension flange yielding does not apply.

(b) When $S_{xt} < S_{xc}$

$$M_n = R_{pt}M_{yt} \quad (6.10.79)$$

Where,

$$M_{yt} = F_y S_{xt}$$

The web plastification factor corresponding to the tension flange yielding limit state, R_{pt} , is determined as follows:

(i) For $\frac{h_c}{t_w} \leq \lambda_{pw}$

$$R_{pt} = \frac{M_p}{M_{yt}} \quad (6.10.80a)$$

(ii) For $\frac{h_c}{t_w} > \lambda_{pw}$

$$R_{pt} = \left[\frac{M_p}{M_{yt}} - \left(\frac{M_p}{M_{yt}} - 1 \right) \left(\frac{\lambda - \lambda_{pw}}{\lambda_{rw} - \lambda_{pw}} \right) \right] \leq \frac{M_p}{M_{yt}} \quad (6.10.80b)$$

Where,

$$\lambda = \frac{h_c}{t_w}$$

$\lambda_{pw} = \lambda_p$, the limiting slenderness for a compact web, defined in Table 6.10.1

$\lambda_{rw} = \lambda_r$, the limiting slenderness for a noncompact web, defined in Table 6.10.1

10.6.5 Doubly Symmetric and Singly Symmetric I-Shaped Members with Slender Webs Bent about Major Axis

This Section applies to doubly symmetric and singly symmetric I-shaped members with slender webs attached to the mid-width of the flanges, bent about their major axis, as defined in Sec10.2.4.

The nominal flexural strength M_n , shall be the lowest value obtained according to the limit states of compression flange yielding, lateral-torsional buckling, compression flange local buckling and tension flange yielding.

10.6.5.1 Compression flange yielding

$$M_n = R_{pg} F_y S_{xc} \quad (6.10.81)$$

10.6.5.2 Lateral-torsional buckling

$$M_n = R_{pg} F_{cr} S_{xc} \quad (6.10.82)$$

(a) When $L_b \leq L_p$, the limit state of lateral-torsional buckling does not apply.

(b) When $L_p < L_b \leq L_r$

$$F_{cr} = C_b \left[F_y - (0.3F_y) \left(\frac{L_b - L_p}{L_r - L_p} \right) \right] \leq F_y \quad (6.10.83)$$

(c) When $L_b > L_r$

$$F_{cr} = \frac{C_b \pi^2 E}{\left(\frac{L_b}{r_t} \right)^2} \leq F_y \quad (6.10.84)$$

Where,

L_p is defined by Eq.6.10.72

$$L_r = \pi r_t \sqrt{\frac{E}{0.7F_y}} \quad (6.10.85)$$

R_{pg} is the bending strength reduction factor:

$$R_{pg} = 1 - \frac{a_w}{1200 + 300a_w} \left(\frac{h_c}{t_w} - 5.7 \sqrt{\frac{E}{F_y}} \right) \leq 1.0 \quad (6.10.86)$$

a_w is defined by Eq.6.10.76 but shall not exceed 10 and

r_t is the effective radius of gyration for lateral buckling as defined in Sec10.6.4.

10.6.5.3 Compression flange local buckling

$$M_n = R_{pg} F_{cr} S_{xc} \quad (6.10.87)$$

- (a) For sections with compact flanges, the limit state of compression flange local buckling does not apply.
- (b) For sections with noncompact flanges

$$F_{cr} = \left[F_y - (0.3F_y) \left(\frac{\lambda - \lambda_{pf}}{\lambda_{rf} - \lambda_{pf}} \right) \right] \quad (6.10.88)$$

- (c) For sections with slender flanges

$$F_{cr} = \frac{0.9Ek_c}{\left(\frac{b_f}{2t_f} \right)^2} \quad (6.10.89)$$

Where,

$k_c = \frac{4}{\sqrt{h/t_w}}$, and shall not be taken less than 0.35 nor greater than 0.76 for calculation purposes

$$\lambda = \frac{b_{fc}}{2t_{fc}}$$

$\lambda_{pf} = \lambda_p$, the limiting slenderness for a compact flange, Table 6.10.1

$\lambda_{rf} = \lambda_r$, the limiting slenderness for a noncompact flange, Table 6.10.1

10.6.5.4 Tension flange yielding

- (a) When $S_{xt} \geq S_{xc}$, the limit state of tension flange yielding does not apply.
- (b) When $S_{xt} < S_{xc}$

$$M_n = F_y S_{xt} \quad (6.10.90)$$

10.6.6 I-Shaped Members and Channels Bent about Their Minor Axis

This Section applies to I-shaped members and channels bent about their minor axis.

The nominal flexural strength, M_n , shall be the lower value obtained according to the limit states of yielding (plastic moment) and flange local buckling.

10.6.6.1 Yielding

$$M_n = M_p = F_y Z_y \leq 1.6 F_y S_y \quad (6.10.91)$$

10.6.6.2 Flange local buckling

- (a) For sections with compact flanges the limit state of yielding shall apply.
 (b) For sections with noncompact flanges

$$M_n = \left[M_p - (M_p - 0.7 F_y S_y) \left(\frac{\lambda - \lambda_{pf}}{\lambda_{rf} - \lambda_{pf}} \right) \right] \quad (6.10.92)$$

- (c) For sections with slender flanges

$$M_n = F_{cr} S_y \quad (6.10.93)$$

Where,

$$F_{cr} = \frac{0.69E}{\left(\frac{b_f}{2t_f} \right)^2} \quad (6.10.94)$$

$$\lambda = \frac{b}{t}$$

$\lambda_{pf} = \lambda_p$, the limiting slenderness for a compact flange, Table 6.10.1

$\lambda_{rf} = \lambda_r$, the limiting slenderness for a noncompact flange, Table 6.10.1

S_y for a channel shall be taken as the minimum section modulus

10.6.7 Square and Rectangular HSS and Box-Shaped Members

This section applies to square and rectangular HSS, and doubly symmetric box-shaped members bent about either axis, having compact or noncompact webs and compact, noncompact or slender flanges as defined in Sec10.2.4.

The nominal flexural strength, M_n , shall be the lowest value obtained according to the limit states of yielding (plastic moment), flange local buckling and web local buckling under pure flexure.

10.6.7.1 Yielding

$$M_n = M_p = F_y Z \quad (6.10.95)$$

Where,

Z = plastic section modulus about the axis of bending, mm^3

10.6.7.2 Flange local buckling

(a) For compact sections, the limit state of flange local buckling does not apply.

(b) For sections with noncompact flanges

$$M_n = M_p - (M_p - F_y S) \left(3.57 \frac{b}{t} \sqrt{\frac{F_y}{E}} - 4.0 \right) \leq M_p \quad (6.10.96)$$

(b) For sections with slender flanges

$$M_n = F_y S_{eff} \quad (6.10.97)$$

Where, S_{eff} is the effective section modulus determined with the effective width of the compression flange taken as:

$$b_e = 1.92t \sqrt{\frac{E}{F_y}} \left[1 - \frac{0.38}{b/t} \sqrt{\frac{E}{F_y}} \right] \leq b \quad (6.10.98)$$

10.6.7.3 Web local buckling

(a) For compact sections, the limit state of web local buckling does not apply.

(b) For sections with noncompact webs

$$M_n = M_p - (M_p - F_y S_x) \left(0.305 \frac{h}{t_w} \sqrt{\frac{F_y}{E}} - 0.738 \right) \leq M_p \quad (6.10.99)$$

10.6.8 Round HSS

This Section applies to round *HSS* having D/t ratios of less than $\frac{0.45E}{F_y}$

The nominal flexural strength, M_n , shall be the lower value obtained according to the limit states of yielding (plastic moment) and local buckling.

10.6.8.1 Yielding

$$M_n = M_p = F_y Z \quad (6.10.100)$$

10.6.8.2 Local buckling

- (a) For compact sections, the limit state of flange local buckling does not apply.
 (b) For noncompact sections

$$M_n = \left(\frac{0.021E}{\frac{D}{t}} + F_y \right) S \quad (6.10.101)$$

- (b) For sections with slender walls

$$M_n = F_{cr} S \quad (6.10.102)$$

Where,

$$F_{cr} = \frac{0.33E}{\frac{D}{t}} \quad (6.10.103)$$

S = elastic section modulus, mm³

10.6.9 Tees and Double Angles Loaded in the Plane of Symmetry

This Section applies to tees and double angles loaded in the plane of symmetry. The nominal flexural strength, M_n , shall be the lowest value obtained according to the limit states of yielding (plastic moment), lateral-torsional buckling and flange local buckling.

10.6.9.1 Yielding

$$M_n = M_p \quad (6.10.104)$$

Where,

$$M_p = F_y Z_x \leq 1.6 M_y \text{ for stems in tension} \quad (6.10.105)$$

$$\leq M_y \text{ for stems in compression} \quad (6.10.106)$$

10.6.9.2 Lateral-torsional buckling

$$M_n = M_{cr} = \frac{\pi \sqrt{EI_y GJ}}{L_b} [B + \sqrt{1 + B^2}] \quad (6.10.107)$$

Where,

$$B = \pm 2.3 \left(\frac{d}{L_b} \right) \sqrt{\frac{I_y}{J}} \quad (6.10.108)$$

The plus sign for B applies when the stem is in tension and the minus sign applies when the stem is in compression. If the tip of the stem is in compression anywhere along the unbraced length, the negative value of B shall be used.

10.6.9.3 Flange local buckling of tees

$$M_n = F_{cr} S_{xc} \quad (6.10.109)$$

S_{xc} is the elastic section modulus referred to the compression flange.

F_{cr} is determined as follows:

- (a) For compact sections, the limit state of flange local buckling does not apply.
- (b) For noncompact sections

$$F_{cr} = F_y \left(1.19 - 0.50 \left(\frac{b_f}{2t_f} \right) \sqrt{\frac{F_y}{E}} \right) \quad (6.10.110)$$

- (c) For slender sections

$$F_{cr} = \frac{0.69E}{\left(\frac{b_f}{2t_f} \right)^2} \quad (6.10.111)$$

10.6.10 Single Angle

This Section applies to single angles with and without continuous lateral restraint along their length.

Single angles with continuous lateral-torsional restraint along the length shall be permitted to be designed on the basis of geometric axis (x, y) bending. Single angles without continuous lateral-torsional restraint along the length shall be designed using the provisions for principal axis bending except where the provision for bending about a geometric axis is permitted.

The nominal flexural strength, M_n , shall be the lowest value obtained according to the limit states of yielding (plastic moment), lateral-torsional buckling and leg local buckling.

10.6.10.1 Yielding

$$M_n = 1.5M_y \quad (6.10.112)$$

Where, M_y = yield moment about the axis of bending, N-mm

10.6.10.2 Lateral-torsional buckling

For single angles without continuous lateral-torsional restraint along the length

(a) When $M_e \leq M_y$

$$M_n = \left(0.92 - \frac{0.17M_e}{M_y}\right) M_e \quad (6.10.113)$$

(b) When $M_e > M_y$

$$M_n = \left(1.92 - 1.17\sqrt{\frac{M_y}{M_e}}\right) M_y \leq 1.5M_y \quad (6.10.114)$$

Where, M_e , the elastic lateral-torsional buckling moment, is determined as follows:

(i) For bending about one of the geometric axes of an equal-leg angle with no lateral-torsional restraint

(a) With maximum compression at the toe

$$M_e = \frac{0.66Eb^4tC_b}{L^2} \left(\sqrt{1 + 0.78\left(\frac{Lt}{b^2}\right)^2} - 1 \right) \quad (6.10.115a)$$

(b) With maximum tension at the toe

$$M_e = \frac{0.66Eb^4tC_b}{L^2} \left(\sqrt{1 + 0.78\left(\frac{Lt}{b^2}\right)^2} + 1 \right) \quad (6.10.115b)$$

M_y shall be taken as 0.80 times the yield moment calculated using the geometric section modulus.

(ii) For bending about one of the geometric axes of an equal-leg angle with lateral-torsional restraint at the point of maximum moment only

M_e shall be taken as 1.25 times M_e computed using Eq.6.10.115a or Eq.6.10.115b.

M_y shall be taken as the yield moment calculated using the geometric section modulus.

(iii) For bending about the major principal axis of equal-leg angles:

$$M_e = \frac{0.46Eb^2t^2C_b}{L} \quad (6.10.116)$$

(iv) For bending about the major principal axis of unequal-leg angles:

$$M_e = \frac{4.9EI_z C_b}{L^2} \left(\sqrt{\beta_w^2 + 0.052 \left(\frac{Lt}{r_z} \right)^2} + \beta_w \right) \quad (6.10.117)$$

Where,

C_b is computed using Eq.6.10.55 with a maximum value of 1.5.

L = laterally unbraced length of a member, mm

I_z = minor principal axis moment of inertia, mm⁴

r_z = radius of gyration for the minor principal axis, mm

t = angle leg thickness, mm

β_w = a section property for unequal leg angles, positive for short legs in compression and negative for long legs in compression. If the long leg is in compression anywhere along the unbraced length of the member, the negative value of β_w shall be used.

10.6.10.3 Leg local buckling

The limit state of leg local buckling applies when the toe of the leg is in compression.

(a) For compact sections, the limit state of leg local buckling does not apply.

(b) For sections with noncompact legs:

$$M_n = F_y S_c \left(2.43 - 1.72 \left(\frac{b}{t} \right) \sqrt{\frac{F_y}{E}} \right) \quad (6.10.118)$$

(c) For sections with slender legs

$$M_n = F_{cr} S_c \quad (6.10.119)$$

Where,

$$F_{cr} = \frac{0.71E}{\left(\frac{b}{t} \right)^2} \quad (6.10.120)$$

b = outside width of leg in compression, mm

S_c = elastic section modulus to the toe in compression relative to the axis of bending, mm^3 . For bending about one of the geometric axes of an equal-leg angle with no lateral-torsional restraint, S_c shall be 0.80 of the geometric axis section modulus.

10.6.11 Rectangular Bars and Rounds

This Section applies to rectangular bars bent about either-geometric axis and rounds.

The nominal flexural strength, M_n , shall be the lower value obtained according to the limit states of yielding (plastic moment) and lateral-torsional buckling, as required.

10.6.11.1 Yielding

For rectangular bars with $\frac{L_b d}{t^2} \leq \frac{0.08E}{F_y}$ bent about their major axis, rectangular bars bent about their minor axis and rounds:

$$M_n = M_p = F_y Z \leq 1.6M_y \quad (6.10.121)$$

10.6.11.2 Lateral-torsional buckling

(a) For rectangular bars with $\frac{0.08E}{F_y} < \frac{L_b d}{t^2} \leq \frac{1.9E}{F_y}$ bent about their major axis:

$$M_n = C_b \left[1.52 - 0.274 \left(\frac{L_b d}{t^2} \right) \frac{F_y}{E} \right] M_y \leq M_p \quad (6.10.122)$$

(b) For rectangular bars with $\frac{L_b d}{t^2} > \frac{1.9E}{F_y}$ bent about their major axis:

$$M_n = F_{cr} S_x \leq M_p \quad (6.10.123)$$

Where,

$$F_{cr} = \frac{1.9EC_b}{\frac{L_b d}{t^2}} \quad (6.10.124)$$

t = width of rectangular bar parallel to axis of bending, mm

d = depth of rectangular bar, mm

L_b = length between points that are either braced against lateral displacement of the compression region or braced against twist of the cross section, mm

(c) For rounds and rectangular bars bent about their minor axis, the limit state of lateral-torsional buckling need not be considered.

10.6.12 Unsymmetrical Shapes

This Section applies to all unsymmetrical shapes, except single angles.

The nominal flexural strength, M_n , shall be the lowest value obtained according to the limit states of yielding (yield moment), lateral-torsional buckling and local buckling where

$$M_n = F_n S \quad (6.10.125)$$

Where, S = lowest elastic section modulus relative to the axis of bending, mm^3

10.6.12.1 Yielding

$$F_n = F_y \quad (6.10.126)$$

10.6.12.2 Lateral-torsional buckling

$$F_n = F_{cr} \leq F_y \quad (6.10.127)$$

Where, F_{cr} = buckling *stress* for the section as determined by analysis, MPa

10.6.12.3 Local buckling

$$F_n = F_{cr} \leq F_y \quad (6.10.128)$$

Where, F_{cr} = buckling *stress* for the section as determined by analysis, MPa

10.6.13 Proportions of Beams and Girders

10.6.13.1 Hole reductions

This Section applies to rolled or built-up shapes, and cover-plated *beams* with holes, proportioned on the basis of flexural strength of the gross section.

In addition to the limit states specified in other sections of this Chapter, the nominal flexural strength, M_n , shall be limited according to the limit state of tensile rupture of the tension flange.

For, $F_u A_{fn} \geq Y_t F_y A_{fg}$, the limit state of tensile rupture does not apply.

For, $F_u A_{fn} < Y_t F_y A_{fg}$, the nominal flexural strength, M_n , at the location of the holes in the tension flange shall not be taken greater than:

$$M_n = \frac{F_u A_{fn}}{A_{fg}} S_x \quad (6.10.129)$$

Where,

A_{fg} = gross tension flange area, calculated in accordance with the provisions of Sec 10.4.3.1, mm²

A_{fn} = net tension flange area, calculated in accordance with the provisions of Sec 10.4.3.2, mm²

$Y_t = 1.0$ for $F_y/E_u \leq 0.8$
 = 1.1 otherwise

10.6.13.2 Proportioning limits for i-shaped members

Singly symmetric I-shaped members shall satisfy the following limit:

$$0.1 \leq \frac{I_{yc}}{I_y} \leq 0.9 \quad (6.10.130)$$

I-shaped members with slender webs shall also satisfy the following limits:

(a) For $\frac{a}{h} \leq 1.5$

$$\left(\frac{h}{t_w}\right)_{max} = 11.7 \sqrt{\frac{E}{F_y}} \quad (6.10.131)$$

(b) For $\frac{a}{h} > 1.5$

$$\left(\frac{h}{t_w}\right)_{max} = \frac{0.42E}{F_y} \quad (6.10.132)$$

Where, a = clear distance between transverse stiffeners, mm

In unstiffened girders $\frac{h}{t_w}$ shall not exceed 260. The ratio of the web area to the compression flange area shall not exceed 10.

10.6.13.3 Cover plates

Flanges of welded beams or girders may be varied in thickness or width by splicing a series of plates or by the use of cover plates.

The total cross-sectional area of cover plates of bolted girders shall not exceed 70 percent of the total flange area.

High-strength bolts or welds connecting flange to web, or cover plate to flange, shall be proportioned to resist the total horizontal shear resulting from the bending forces on the girder. The longitudinal distribution of these bolts or intermittent welds shall be in proportion to the intensity of the shear.

However, the longitudinal spacing shall not exceed the maximum permitted for compression or tension members in Sec 10.5.6 or 10.4.4, respectively. Bolts or welds connecting flange to web shall also be proportioned to transmit to web any loads applied directly to the flange, unless provision is made to transmit such loads by direct bearing.

Partial-length cover plates shall be extended beyond the theoretical cutoff point and the extended portion shall be attached to the beam or girder by high-strength bolts in a slip-critical connection or fillet welds. The attachment shall be adequate, at the applicable strength given in Sections 10.10.2.2, 10.10.3.8, or 10.2.3.9 to develop the cover plate's portion of the flexural strength in the beam or girder at the theoretical cutoff point.

For welded cover plates, the welds connecting the cover plate termination to the beam or girder shall have continuous welds along both edges of the cover plate in the length a' , defined below, and shall be adequate to develop the cover plate's portion of the strength of the beam or girder at the distance a' from the end of the cover plate.

- (a) When there is a continuous weld equal to or larger than three-fourths of the plate thickness across the end of the plate

$$a' = w \quad (6.10.133)$$

Where, w = width of cover plate, mm.

- (b) When there is a continuous weld smaller than three-fourths of the plate thickness across the end of the plate

$$a' = 1.5w \quad (6.10.134)$$

- (c) When there is no weld across the end of the plate

$$a' = 2w \quad (6.10.135)$$

10.6.13.4 Built-up beams

Where two or more beams or channels are used side-by-side to form a flexural member, they shall be connected together in compliance with Sec 10.5.6.2. When concentrated loads are carried from one beam to another, or distributed between the beams, diaphragms having sufficient stiffness to distribute the load shall be welded or bolted between the beams.

10.7 Design Of Members For Shear

This Section addresses webs of singly or doubly symmetric members subject to shear in the plane of the web, single angles and HSS sections, and shear in the weak direction of singly or doubly symmetric shapes.

10.7.1 General Provisions

Two methods of calculating shear strength are presented below. The method presented in Sec 10.7.2 does not utilize the post buckling strength of the member (tension field action). The method presented in Sec 10.7.3 utilizes tension field action.

The design shear strength, $\phi_v V_n$ and the allowable shear strength, V_n/Ω_v , shall be determined as follows.

For all provisions in this Section except Sec 10.7.2.1(a):

$$\phi_v = 0.90 \text{ (LRFD)} \quad \Omega_v = 1.67 \text{ (ASD)}$$

10.7.2 Members with Unstiffened or Stiffened Webs

10.7.2.1 Nominal shear strength

This Section applies to webs of singly or doubly symmetric members and channels subject to shear in the plane of the web.

The nominal shear strength, V_n , of unstiffened or stiffened webs, according to the limit states of shear yielding and shear buckling, is

$$V_n = 0.6F_y A_w C_w \quad (6.10.136)$$

(a) For webs of rolled I-shaped members with $h/t_w \leq 2.24\sqrt{E/F_y}$

$$\phi_v = 1.00 \text{ (LRFD)} \quad \Omega_v = 1.50 \text{ (ASD)}$$

And,

$$C_v = 1.0 \quad (6.10.137)$$

(b) For webs of all other doubly symmetric shapes and singly symmetric shapes and channels, except round HSS, the web shear coefficient, C_v , is determined as follows:

(i) For $h/t_w \leq 1.10\sqrt{k_v E/F_y}$

$$C_v = 1.0 \quad (6.10.138)$$

(ii) For $1.10\sqrt{k_v E/F_y} < h/t_w \leq 1.37\sqrt{k_v E/F_y}$

$$C_v = \frac{1.10\sqrt{k_v E/F_y}}{h/t_w} \quad (6.10.139)$$

(iii) For $h/t_w > 1.37\sqrt{k_v E/F_y}$

$$C_v = \frac{1.51Ek_v}{(h/t_w)^2 F_y} \quad (6.10.140)$$

Where

A_w = the overall depth times the web thickness, dt_w , mm²

The web plate buckling coefficient, k_v , is determined as follows:

(i) For unstiffened webs with $h/t_w < 260$, $k_v = 5$ except for the stem of tee shapes where, $k_v = 1.2$.

(ii) For stiffened webs,

$$k_v = 5 + \frac{5}{(a/h)^2}$$

$$= 5 \text{ when } a/h > 3.0 \text{ or } a/h > \left[\frac{260}{(h/t_w)} \right]^2$$

Where,

a = clear distance between transverse stiffeners, mm

h = for rolled shapes, the clear distance between flanges less the fillet or corner radii, mm

= for built-up welded sections, the clear distance between flanges, mm

= for built-up bolted sections, the distance between fastener lines, mm

= for tees, the overall depth, mm.

10.7.2.2 Transverse stiffeners

Transverse stiffeners are not required where $h/t_w \leq 2.46\sqrt{E/F_y}$, or where the required shear strength is less than or equal to the available shear strength provided in accordance with Sec10.7.2.1 for $k_v = 5$.

Transverse stiffeners used to develop the available web shear strength, as provided in Sec 10.7.2.1, shall have a moment of inertia about an axis in the web center for stiffener pairs or about the face in contact with the web plate for single stiffeners, which shall not be less than $at_w^3 j$, where

$$j = \frac{2.5}{(a/h)^2} - 2 \geq 0.5 \quad (6.10.141)$$

Transverse stiffeners are permitted to be stopped short of the tension flange, provided bearing is not needed to transmit a concentrated load or reaction. The weld by which transverse stiffeners are attached to the web shall be terminated not less than four times nor more than six times the web thickness from the near toe to the web-to-flange weld. When single stiffeners are used, they shall be attached to the compression flange, if it consists of a rectangular plate, to resist any uplift tendency due to torsion in the flange. When lateral bracing is attached to a stiffener, or a pair of stiffeners, these, in turn, shall be connected to the compression flange to transmit 1 percent of the total flange force, unless the flange is composed only of angles.

Bolts connecting stiffeners to the girder web shall be spaced not more than 305 mm on center. If intermittent fillet welds are used, the clear distance between welds shall not be more than 16 times the web thickness nor more than 250 mm.

10.7.3 Tension Field Action

10.7.3.1 Limits on the use of tension field action

Consideration of tension field action is permitted for flanged members when the web plate is supported on all four sides by flanges or stiffeners. Consideration of tension field action is not permitted for:

End panels in all members with transverse stiffeners;

Members when a/h exceeds 3.0 or $[260/(h/t_w)]^2$;

$$2 A_w / (A_{fc} + A_{ft}) > 2.5; \text{ or}$$

$$h/b_{fc} \text{ or } h/b_{ft} > 6.0$$

Where,

A_{fc} = area of compression flange, mm²

A_{ft} = area of tension flange, mm²

b_{fc} = width of compression flange, mm

b_{ft} = width of tension flange, mm

In these cases, the nominal shear strength, V_n , shall be determined according to the provisions of Sec 10.7.2.

10.7.3.2 Nominal shear strength with tension field action

When tension field action is permitted according to Sec 10.7.3.1, the nominal shear strength, V_n , with tension field action, according to the limit state of tension field yielding, shall be

For, $h/t_w \leq 1.10\sqrt{k_v E/F_y}$

$$V_n = 0.6F_y A_w \quad (6.10.142)$$

For, $h/t_w > 1.10\sqrt{k_v E/F_y}$

$$V_n = 0.6F_y A_w \left(C_v + \frac{1-C_v}{1.15\sqrt{1+(a/h)^2}} \right) \quad (6.10.143)$$

Where, k_v and C_v are as defined in Sec 10.7.2.1.

10.7.3.3 Transverse stiffeners

Transverse stiffeners subject to tension field action shall meet the requirements of Sec 10.7.2.2 and the following limitations:

$$(b/t)_{st} \leq 0.56 \sqrt{\frac{E}{F_{yst}}}$$

$$A_{st} > \frac{F_y}{F_{yst}} \left[0.15D_s h t_w (1 - C_v) \frac{V_r}{V_c} - 18t_w^2 \right] \geq 0 \quad (6.10.144)$$

Where,

$(b/t)_{st}$ = the width-thickness ratio of the stiffener

F_{yst} = specified minimum yield stress of the stiffener material, MPa

C_v = coefficient defined in Sec 10.7.2.1

D_s = 1.0 for stiffeners in pairs
 = 1.8 for single angle stiffeners
 = 2.4 for single plate stiffeners

V_r = required shear strength at the location of the stiffener, N

V_c = available shear strength; $\phi_v V_n$ (LRFD) or V_n/Ω_v (ASD) with V_n as defined in Sec 10.7.3.2, N

10.7.4 Single Angles

The nominal shear strength, V_n , of a single angle leg shall be determined using Eq.6.10.136 with $C_v = 1.0$, $A_w = b_t$ where b = width of the leg resisting the shear force, mm and $k_v = 1.2$.

10.7.5 Rectangular HSS and Box Members

The nominal shear strength, V_n , of rectangular HSS and box members shall be determined using the provisions of Sec 10.7.2.1 with $A_w = 2ht$ where h for the width resisting the shear force shall be taken as the clear distance between the flanges less the inside corner radius on each side and $t_w = t$ and $k_y = 5$. If the corner radius is not known, h shall be taken as the corresponding outside dimension minus three times the thickness.

10.7.6 Round HSS

The nominal shear strength, V_n of round HSS, according to the limit states of shear yielding and shear buckling, is

$$V_n = F_{cr} A_g / 2 \quad (6.10.145)$$

Where,

F_{cr} shall be the larger of

$$F_{cr} = \frac{1.60E}{\sqrt{\frac{L_v(D)}{D} \left(\frac{D}{t}\right)^{\frac{5}{4}}}} \quad (6.10.146a)$$

And,

$$F_{cr} = \frac{0.78E}{\left(\frac{D}{t}\right)^{\frac{3}{2}}} \quad (6.10.146b)$$

But shall not exceed $0.6 F_y$

A_g = gross area of section based on design wall thickness, mm²

D = outside diameter, mm

L_v = the distance from maximum to zero shear force, mm

T = design wall thickness, equal to 0.93 times the nominal wall thickness for ERW HSS and equal to the nominal thickness for SAW HSS, mm

10.7.7 Weak Axis Shear in Singly and Doubly Symmetric Shapes

For singly and doubly symmetric shapes loaded in the weak axis without torsion, the nominal shear strength, V_n , for each shear resisting element shall be determined using Eq. 6.10.136 and Sec 10.7.2.1b with $A_w = b_f t_f$ and $k_v = 1.2$.

10.7.8 Beams and Girders with Web Openings

The effect of all web openings on the nominal shear strength of steel and composite beams shall be determined. Adequate reinforcement shall be provided when the required strength exceeds the available strength of the member at the opening.

10.8 Design of Members for Combined Forces and Torsion

This Section addresses members subject to axial *force* and flexure about one or both axes, with or without torsion, and to members subject to torsion only.

10.8.1 Doubly and Singly Symmetric Members Subject to Flexure and Axial Force**10.8.1.1 Doubly and singly symmetric members in flexure and compression**

The interaction of flexure and compression in doubly symmetric members and singly symmetric members for which $0.1 \leq \left(\frac{I_{yc}}{I_y}\right) \leq 0.9$, that are constrained to bend about a geometric axis (x and/or y) shall be limited by Equations 6.10.147a and 6.10.147b, where I_{yc} is the moment of inertia about the y-axis referred to the compression flange, mm⁴.

For $\frac{P_r}{P_c} \geq 0.2$

$$\frac{P_r}{P_c} + \frac{8}{9} \left(\frac{M_{rx}}{M_{cx}} + \frac{M_{ry}}{M_{cy}} \right) \leq 1.0 \quad (6.10.147a)$$

For $\frac{P_r}{P_c} < 0.2$

$$\frac{P_r}{2P_c} + \left(\frac{M_{rx}}{M_{cx}} + \frac{M_{ry}}{M_{cy}} \right) \leq 1.0 \quad (6.10.147b)$$

Where,

P_r = required axial compressive strength, N

P_c = available axial compressive strength, N

M_r = required flexural strength, N-mm

M_c = available flexural strength, N-mm

x = subscript relating symbol to strong axis bending

y = subscript relating symbol to weak axis bending

For design according to Sec 10.2.3.3 (LRFD)

P_r = required axial compressive strength using LRFD load combinations, N

$P_c = \phi_c P_n$ = design axial compressive strength, determined in accordance with Sec 10.5, N

M_r = required flexural strength using LRFD load combinations, N-mm

$M_c = \phi_b M_n$ = design flexural strength determined in accordance with Sec 10.6, N-mm

ϕ_c = resistance factor for compression = 0.90

ϕ_b = resistance factor for flexure = 0.90

For design according to Sec 10.2.3.4 (ASD)

P_r = required axial compressive strength using ASD load combinations, N

$P_c = P_n / \Omega_c$ = allowable axial compressive strength, determined in accordance with Sec 10.5, N

M_r = required flexural strength using ASD load combinations, N-mm

$M_c = M_n / \Omega_b$ = allowable flexural strength determined in accordance with Sec 10.6, N-mm

Ω_c = safety factor for compression = 1.67

Ω_b = safety factor for flexure = 1.67

10.8.1.2 Doubly and singly symmetric members in flexure and tension

The interaction of flexure and tension in doubly symmetric members and singly symmetric members constrained to bend about a geometric axis (x and/or y) shall be limited by Eq. 6.10.147a and 6.10.147b,

Where,

For design according to Sec 10.2.3.3 (LRFD)

P_r = required tensile strength using LRFD load combinations, N

$P_c = \phi_t P_n$ = design tensile strength, determined in accordance with Sec 10.4.2, N

M_r = required flexural strength using LRFD load combinations, N-mm

$M_c = \phi_b M_n$ = design flexural strength determined in accordance with Sec 10.6, N-mm

ϕ_t = resistance factor for tension (see Sec 10.4.2)

ϕ_b = resistance factor for flexure = 0.90

For doubly symmetric members, C_b in Sec 10.6 may be increased by $\sqrt{1 + \frac{P_u}{P_{ey}}}$ for axial tension that acts concurrently with flexure,

Where,

$$P_{ey} = \frac{\pi^2 EI_y}{L_b^2}$$

For design according to Sec 10.2.3.4 (ASD)

P_r = required tensile strength using ASD load combinations, N

$P_c = P_n / \Omega_t$ = allowable tensile strength, determined in accordance with Sec 10.4.2, N

M_r = required flexural strength using ASD load combinations, N-mm

$M_c = M_n / \Omega_b$ = allowable flexural strength determined in accordance with Sec 10.6, N-mm

Ω_t = safety factor for tension (see Sec 10.4.2)

Ω_b = safety factor for flexure = 1.67

For doubly symmetric members, C_b in Sec 10.6 may be increased by $\sqrt{1 + \frac{1.5P_a}{P_{ey}}}$ for axial tension that acts concurrently with flexure.

Where,

$$P_{ey} = \frac{\pi^2 EI_y}{L_b^2}$$

A more detailed analysis of the interaction of flexure and tension is permitted in lieu of Equations 6.10.147a and 6.10.147b.

10.8.1.3 Doubly symmetric members in single axis flexure and compression

For doubly symmetric members in flexure and compression with moments primarily in one plane, it is permissible to consider the two independent limit states, in-plane instability and

out-of-plane buckling or flexural-torsional buckling, separately in lieu of the combined approach provided in Sec 10.8.1.1.

- (a) For the limit state of in-plane instability, Eq.6.10.147 shall be used with P_c , M_r , and M_c determined in the plane of bending.
- (b) For the limit state of out-of-plane buckling

$$\frac{P_r}{P_{co}} + \left(\frac{M_r}{M_{cx}}\right)^2 \leq 1.0 \quad (6.10.148)$$

Where,

P_{co} = available compressive strength out of the plane of bending, N

M_{cx} = available flexural-torsional strength for strong axis flexure determined from Sec 10.6, N-mm

If bending occurs only about the weak axis, the moment ratio in Eq.6.10.148 shall be neglected.

For members with significant biaxial moments, $\left(\frac{M_r}{M_c}\right) \geq 0.05$ in both directions, the provisions of Sec 10.8.1.1 shall be followed.

10.8.2 Unsymmetric and Other Members Subject to Flexure and Axial Force

This Section addresses the interaction of flexure and axial *stress* for shapes not covered in Sec 10.8.1. It is permitted to use the provisions of this Section for any shape in lieu of the provisions of Sec 10.8.1.

$$\left| \frac{f_a}{F_a} + \frac{f_{bw}}{F_{bw}} + \frac{f_{bz}}{F_{bz}} \right| \leq 1.0 \quad (6.10.149)$$

Where,

f_a = required axial stress at the point of consideration, MPa

F_a = available axial stress at the point of consideration, MPa

f_{bw}, f_{bz} = required flexural stress at the point of consideration, MPa

F_{bw}, F_{bz} = available flexural stress at the point of consideration, MPa

w = subscript relating symbol to major principal axis bending

z = subscript relating symbol to minor principal axis bending

For design according to Sec 10.2.3.3 (LRFD)

f_a = required axial stress using LRFD load combinations, MPa

$F_a = \phi_c F_{cr}$ = design axial stress, determined in accordance with Sec 10.5 for compression or Sec 10.4.2 for tension, MPa

f_{bw}, f_{bz} = required flexural stress at the specific location in the cross section using LRFD load combinations, MPa

$F_{bw}, F_{bz} = \frac{\phi_b M_n}{S}$ = design flexural stress determined in accordance with Sec 10.6, MPa. Use the section modulus for the specific location in the cross section and consider the sign of the stress.

ϕ_c = resistance factor for compression = 0.90

ϕ_t = resistance factor for tension (Sec 10.4.2)

ϕ_b = resistance factor for flexure = 0.90

For design according to Sec 10.2.3.4 (ASD)

f_a = required axial stress using ASD load combinations, MPa

$F_a = \frac{F_{cr}}{\Omega_c}$ = allowable axial stress determined in accordance with Sec 10.5 for compression, or Sec 10.4.2 for tension, MPa

f_{bw}, f_{bz} = required flexural stress at the specific location in cross section using ASD load combinations, MPa

$F_{bw}, F_{bz} = \frac{M_n}{\Omega_b S}$ = allowable flexural stress determined in accordance with Sec 10.6, MPa. Use the section modulus for the specific location in the cross section and consider the sign of the stress.

Ω_c = safety factor for compression = 1.67

Ω_t = safety factor for tension (Sec 10.4.2)

Ω_b = safety factor for flexure = 1.67

Eq.6.10.149 shall be evaluated using the principal bending axes by considering the sense of the flexural stresses at the critical points of the cross section. The flexural terms are either added to or subtracted from the axial term as appropriate. When the axial *force* is compression, second order effects shall be included according to the provisions of Sec 10.3.

A more detailed analysis of the interaction of flexure and tension is permitted in lieu of Eq.6.10.149.

10.8.3 Members under Torsion and Combined Torsion, Flexure, Shear and/or Axial Force

10.8.3.1 Torsional strength of round and rectangular HSS

The design torsional strength, $\phi_T T_n$ and the allowable torsional strength, T_n/Ω_T , for round and rectangular HSS shall be determined as follows:

$$\phi_T = 0.90 \text{ (LRFD)} \quad \Omega_T = 1.67 \text{ (ASD)}$$

The nominal torsional strength, T_n , according to the limit states of torsional yielding and torsional buckling is:

$$T_n = F_{cr} C \quad (6.10.150)$$

Where,

C is the HSS torsional constant

F_{cr} shall be determined as follows:

For round HSS, F_{cr} shall be the larger of

$$F_{cr} = \frac{1.23E}{\sqrt{\frac{L}{D} \left(\frac{D}{t}\right)^{\frac{5}{4}}}} \quad (6.10.151a)$$

And,

$$F_{cr} = \frac{0.60E}{\left(\frac{D}{t}\right)^{\frac{3}{2}}} \quad (6.10.151b)$$

But, shall not exceed $0.6F_y$,

Where,

L = length of the member, mm

D = outside diameter, mm

For rectangular *HSS*

For $h/t \leq 2.45\sqrt{E/F_y}$

$$F_{cr} = 0.6F_y \quad (6.10.152)$$

For $2.45\sqrt{E/F_y} < h/t \leq 3.07\sqrt{E/F_y}$

$$F_{cr} = 0.6F_y \left(2.45\sqrt{E/F_y} \right) / (h/t) \quad (6.10.153)$$

For $3.07\sqrt{E/F_y} < h/t \leq 260$

$$F_{cr} = 0.458\pi^2 E / (h/t)^2 \quad (6.10.154)$$

10.8.3.2 HSS subject to combined torsion, shear, flexure and axial force

When the required torsional strength, T_r , is less than or equal to 20 percent of the available torsional strength, T_c , the interaction of torsion, shear, flexure and/or axial force for *HSS* shall be determined by Sec 10.8.1 and the torsional effects shall be neglected. When T_r exceeds 20 percent of T_c , the interaction of torsion, shear, flexure and/or axial force shall be limited by

$$\left(\frac{P_r}{P_c} + \frac{M_r}{M_c} \right) + \left(\frac{V_r}{V_c} + \frac{T_r}{T_c} \right)^2 \leq 1.0 \quad (6.10.155)$$

Where,

For design according to Sec 10.2.3.3 (LRFD)

P_r =required axial strength using LRFD load combinations, N

$P_c = \phi P_n$, design tensile or compressive strength in accordance with Sec 10.4 or 10.5,
N

M_r =required flexural strength using LRFD load combinations, N-mm

$M_c = \phi_b M_n$, design flexural strength in accordance with Sec 10.6, N-mm

V_r =required shear strength using LRFD load combinations, N

$V_c = \phi_v V_n$, design shear strength in accordance with Sec 10.7, N

T_r =required torsional strength using LRFD load combinations, N-mm

$T_c = \phi_T T_n$, design torsional strength in accordance with Sec 10.8.3.1, N-mm

For design according to Sec 10.2.3.4 (ASD)

P_r = required axial strength using ASD load combinations, N

$P_c = P_n / \Omega$ allowable tensile or compressive strength in accordance with Sec 10.4 or 10.5, N

M_r =required flexural strength using ASD load combinations determined as per Sec10.2.5, N-mm

$M_c = M_n / \Omega_b$, allowable flexural strength in accordance with Sec 10.6, N-mm

V_r = required shear strength using ASD load combinations, N

$V_c = V_n / \Omega_v$, allowable shear strength in accordance with Sec 10.7, N

T_r = required torsional strength using ASD load combinations, N-mm

$T_c = T_n / \Omega_T$, allowable torsional strength in accordance with Sec 10.8.3.1, N-mm

10.8.3.3 Strength of non-HSS members under torsion and combined stress

The design torsional strength, $\phi_T F_n$, and the allowable torsional strength, F_n / Ω_T , for non-HSS members shall be the lowest value obtained according to the limit states of yielding under normal stress, shear yielding under shear stress, or buckling, determined as follows:

$$\phi_T = 0.90 \text{ (LRFD)} \quad \Omega_T = 1.67 \text{ (ASD)}$$

(a) For the limit state of yielding under normal stress

$$F_n = F_y \quad (6.10.156)$$

(b) For the limit state of shear yielding under shear stress

$$F_n = 0.6F_y \quad (6.10.157)$$

(c) For the limit state of buckling

$$F_n = F_{cr} \quad (6.10.158)$$

Where,

F_{cr} = buckling stress for the section as determined by analysis, MPa.

Some constrained local yielding is permitted adjacent to areas that remain elastic.

10.9 Evaluation of Existing Structures

This Section applies to the evaluation of the strength and stiffness under static vertical (gravity) loads of existing structures by structural analysis, by load tests, or by a combination of structural analysis and load tests when specified by the engineer of record or in the contract documents. For such evaluation, the steel grades are not limited to those listed in Sec 10.1.3.1. This Section does not address load testing for the effects of seismic loads or moving loads (vibrations).

10.9.1 General Provisions

These provisions shall be applicable when the evaluation of an existing steel structure is specified for (a) verification of a specific set of design loadings or (b) determination of the available strength of a load resisting member or system. The evaluation shall be performed by structural analysis (Sec 10.9.3), by load tests (Sec 10.9.4), or by a combination of structural analysis and load tests, as specified in the contract documents. Where load tests are used, the engineer of record shall first analyze the structure, prepare a testing plan, and develop a written procedure to prevent excessive permanent deformation or catastrophic collapse during testing.

10.9.2 Material Properties

Determination of Required Tests: The engineer of record shall determine the specific tests that are required from Sections 10.9.2.2 to 10.9.2.6 and specify the locations where they are required. Where available, the use of applicable project records shall be permitted to reduce or eliminate the need for testing.

10.9.2.1 Tensile properties

Tensile properties of members shall be considered in evaluation by structural analysis (Sec 10.9.3) or load tests (Sec 10.9.4). Such properties shall include the yield stress, tensile strength and percent elongation. Where available, certified mill test reports or certified reports of tests made by the fabricator or a testing laboratory in accordance with ASTM A6/A6M or A568/A568M, as applicable, shall be permitted for this purpose. Otherwise, tensile tests shall be conducted in accordance with ASTM A370 from samples cut from components of the structure.

10.9.2.2 Chemical composition

Where welding is anticipated for repair or modification of existing structures, the chemical composition of the steel shall be determined for use in preparing a welding procedure specification (WPS). Where available, results from certified mill test reports or certified reports of tests made by the fabricator or a testing laboratory in accordance with ASTM procedures shall be permitted for this purpose. Otherwise, analyses shall be conducted in accordance with ASTM A751 from the samples used to determine tensile properties, or from samples taken from the same locations.

10.9.2.3 Base metal notch toughness

Where welded tension splices in heavy shapes and plates as defined in Sec 10.1.3.1(d) are critical to the performance of the structure, the Charpy V-Notch toughness shall be determined in accordance with the provisions of Sec 10.1.3.1(d). If the notch toughness so determined does not meet the provisions of Sec 10.1.3.1(d), the engineer of record shall determine if remedial actions are required.

10.9.2.4 Weld metal

Where structural performance is dependent on existing welded connections, representative samples of weld metal shall be obtained. Chemical analysis and mechanical tests shall be made to characterize the weld metal. A determination shall be made of the magnitude and consequences of imperfections. If the requirements of AWS D1.1 are not met, the engineer of record shall determine if remedial actions are required.

10.9.2.5 Bolts and rivets

Representative samples of bolts shall be inspected to determine markings and classifications. Where bolts cannot be properly identified visually, representative samples shall be removed and tested to determine tensile strength in accordance with ASTM F606 or ASTM F606M and the bolt classified accordingly. Alternatively, the assumption that the bolts are ASTM A307 shall be permitted. Rivets shall be assumed to be ASTM A502, Grade 1, unless a higher grade is established through documentation or testing.

10.9.3 Evaluation by Structural Analysis

10.9.3.1 Dimensional data

All dimensions used in the evaluation, such as spans, column heights, member spacings, bracing locations, cross-section dimensions, thicknesses and connection details, shall be determined from a field survey. Alternatively, when available, it shall be permitted to determine such dimensions from applicable project design or shop drawings with field verification of critical values.

10.9.3.2 Strength evaluation

Forces (load effects) in members and connections shall be determined by structural analysis applicable to the type of structure evaluated. The load effects shall be determined for the loads and factored load combinations stipulated in Sec 10.2.2.

The available strength of members and connections shall be determined from applicable provisions of Sections 10.2 to 10.19 of this Specification.

10.9.3.3 Serviceability evaluation

Where required, the deformations at service loads shall be calculated and reported.

10.9.4 Evaluation by Load Tests

10.9.4.1 Determination of load rating by testing

To determine the load rating of an existing floor or roof structure by testing, a test load shall be applied incrementally in accordance with the engineer of record's plan. The structure shall be visually inspected for signs of distress or imminent failure at each load level. Appropriate measures shall be taken if these or any other unusual conditions are encountered.

The tested strength of the structure shall be taken as the maximum applied test load plus the in-situ dead load. The live load rating of a floor structure shall be determined by setting the tested strength equal to $1.2 D + 1.6L$, where D is the nominal dead load and L is the nominal live load rating for the structure. The nominal live load rating of the floor structure shall not exceed that which can be calculated using applicable provisions of the specification. For roof structures, L_r , S , or R as defined in the Symbols, shall be substituted for L . More severe load combinations shall be used if required by specifications of Chapter 2 Part 6.

Periodic unloading shall be considered once the service load level is attained and after the onset of inelastic structural behavior is identified to document the amount of permanent set

and the magnitude of the inelastic deformations. Deformations of the structure, such as member deflections, shall be monitored at critical locations during the test, referenced to the initial position before loading. It shall be demonstrated, while maintaining maximum test load for one hour that the deformation of the structure does not increase by more than 10 percent above that at the beginning of the holding period. It is permissible to repeat the sequence if necessary to demonstrate compliance.

Deformations of the structure shall also be recorded 24 hours after the test loading is removed to determine the amount of permanent set. Because the amount of acceptable permanent deformation depends on the specific structure, no limit is specified for permanent deformation at maximum loading. Where it is not feasible to load test the entire structure, a segment or zone of not less than one complete bay, representative of the most critical conditions, shall be selected.

10.9.4.2 Serviceability evaluation

When load tests are prescribed, the structure shall be loaded incrementally to the service load level. Deformations shall be monitored for a period of one hour. The structure shall then be unloaded and the deformation recorded.

10.9.5 Evaluation Report

After the evaluation of an existing structure has been completed, the engineer of record shall prepare a report documenting the evaluation. The report shall indicate whether the evaluation was performed by structural analysis, by load testing or by a combination of structural analysis and load testing. Furthermore, when testing is performed, the report shall include the loads and load combination used and the load-deformation and time-deformation relationships observed. All relevant information obtained from design drawings, mill test reports and auxiliary material testing shall also be reported. Finally, the report shall indicate whether the structure, including all members and connections, is adequate to withstand the load effects.

10.10 Connections

This Section addresses connecting elements, connectors, and the affected elements of the connected members not subject to fatigue loads.

10.10.1 General Provisions

10.10.1.1 Design basis

The design strength, ϕR_n and the allowable strength $\frac{R_n}{\Omega}$, of connections shall be determined in accordance with the provisions of this Section and the provisions of Sec 10.2.

The required strength of the connections shall be determined by structural analysis for the specified design loads, consistent with the type of construction specified, or shall be a proportion of the required strength of the connected members when so specified herein.

Where the gravity axes of intersecting axially loaded members do not intersect at one point, the effects of eccentricity shall be considered.

10.10.1.2 Simple connection

Simple connections of beams, girders, or trusses shall be designed as flexible and are permitted to be proportioned for the reaction shears only, except as otherwise indicated in the design documents. Flexible beam connections shall accommodate end rotations of simple beams. Some inelastic, but self-limiting deformation in the connection is permitted to accommodate the end rotation of a simple beam.

10.10.1.3 Moment connection

End connections of restrained beams, girders, and trusses shall be designed for the combined effect of forces resulting from moment and shear induced by the rigidity of the connections. Response criteria for moment connections are provided in Sec 10.2.6.3.2.

10.10.1.4 Compression members with bearing joints

- (a) When columns bear on bearing plates or are finished to bear at splices, there shall be sufficient connectors to hold all parts securely in place.
- (b) When compression members other than columns are finished to bear, the splice material and its connectors shall be arranged to hold all parts in line and shall be proportioned for either (i) or (ii) below. It is permissible to use the less severe of the two conditions:
 - (i) An axial tensile force of 50 percent of the required compressive strength of the member; or
 - (ii) The moment and shear resulting from a transverse load equal to 2 percent of the required compressive strength of the member. The transverse load shall be applied at the location of the splice exclusive of other loads that act on the member. The member shall be taken as pinned for the determination of the shears and moments at the splice.

10.10.1.5 Splices in heavy sections

When tensile forces due to applied tension or flexure are to be transmitted through splices in heavy sections, as defined in Sections 10.1.3.1(c) and 10.1.3.1(d), by complete-joint-penetration groove (CJP) welds, material notch-toughness requirements as given in

Sections 10.1.3.1(c) and 10.1.3.1(d), weld access hole details as given in Sec 10.10.1.6 and thermal cut surface preparation and inspection requirements as given in Sec 10.1.3.2.2 shall apply. The foregoing provision is not applicable to splices of elements of built-up shapes that are welded prior to assembling the shape.

10.10.1.6 Beam copes and weld access holes

All weld access holes required to facilitate welding operations shall have a length from the toe of the weld preparation not less than $1\frac{1}{2}$ times the thickness of the material in which the hole is made. The height of the access hole shall be $1\frac{1}{2}$ times the thickness of the material with the access hole, t_w , but not less than 25 mm nor does it need to exceed 50 mm. The access hole shall be detailed to provide room for weld backing as needed.

For sections that are rolled or welded prior to cutting, the edge of the web shall be sloped or curved from the surface of the flange to the reentrant surface of the access hole. In hot-rolled shapes, and built-up shapes with CJP groove welds that join the web-to-flange, all beam copes and weld access holes shall be free of notches and sharp reentrant corners. No arc of the weld access hole shall have a radius less than 10 mm.

In built-up shapes with fillet or partial-joint-penetration groove welds that join the web-to-flange, all beam copes and weld access holes shall be free of notches and sharp reentrant corners. The access hole shall be permitted to terminate perpendicular to the flange, providing the weld is terminated at least a distance equal to the weld size away from the access hole.

For heavy sections as defined in Sections 10.1.3.1(c) and 10.1.3.1(d), the thermally cut surfaces of beam copes and weld access holes shall be ground to bright metal and inspected by either magnetic particle or dye penetrant methods prior to deposition of splice welds. If the curved transition portion of weld access holes and beam copes are formed by predrilled or sawed holes, that portion of the access hole or cope need not be ground. Weld access holes and beam copes in other shapes need not be ground nor inspected by dye penetrant or magnetic particle methods.

10.10.1.7 Placement of welds and bolts

Groups of welds or bolts at the ends of any member which transmit axial force into that member shall be sized so that the center of gravity of the group coincides with the center of gravity of the member, unless provision is made for the eccentricity. The foregoing provision is not applicable to end connections of statically loaded single angle, double angle, and similar members.

10.10.1.8 Bolts in combination with welds

Bolts shall not be considered as sharing the load in combination with welds, except that shear connections with any grade of bolts permitted by Sec 10.1.3.3 installed in standard holes or short slots transverse to the direction of the load are permitted to be considered to share the load with longitudinally loaded fillet welds. In such connections the available strength of the bolts shall not be taken as greater than 50 percent of the available strength of bearing-type bolts in the connection.

In making welded alterations to structures, existing rivets and high strength bolts tightened to the requirements for slip-critical connections are permitted to be utilized for carrying loads present at the time of alteration and the welding need only provide the additional required strength.

10.10.1.9 High-strength bolts in combination with rivets

In both new work and alterations, in connections designed as slip-critical connections in accordance with the provisions of Sec 10.10.3, high-strength bolts are permitted to be considered as sharing the load with existing rivets.

10.10.1.10 Limitations on bolted and welded connections

Pretensioned joints, slip-critical joints or welds shall be used for the following connections:

Column splices in all multi-story structures over 38 m in height

Connections of all beams and girders to columns and any other beams and girders on which the bracing of columns is dependent in structures over 38 m in height

In all structures carrying cranes of over 50 kN capacity: roof truss splices and connections of trusses to columns, column splices, column bracing, knee braces, and crane supports

Connections for the support of machinery and other live loads that produce impact or reversal of load

Snug-tightened joints or joints with ASTM A307 bolts shall be permitted except where otherwise specified.

10.10.2 Welds

All provisions of AWS D1.1 apply under this specification, with the exception that the provisions of the listed Sections apply under this specification in lieu of the cited AWS provisions as follows:

Sec 10.10.1.6 in lieu of AWS D1.1 Section 5.17.1

Sec 10.10.2.2.1 in lieu of AWS D1.1 Section 2.3.2

Table 6.10.5 in lieu of AWS D1.1 Table 2.1

Table 6.10.8 in lieu of AWS D1.1 Table 2.3

Table 6.10.14 in lieu of AWS D1.1 Table 2.4

Sec 10.2.3.9 and Sec 10.17 in lieu of AWS D1.1 Section 2, Part C

Sec 10.13.2.2 in lieu of AWS D1.1 Sections 5.15.4.3 and 5.15.4.4

10.10.2.1 Groove welds**10.10.2.1.1 Effective area**

The effective area of groove welds shall be considered as the length of the weld times the effective throat thickness.

The effective throat thickness of a complete-joint-penetration (CJP) groove weld shall be the thickness of the thinner part joined. The effective throat thickness of a partial-joint-penetration (PJP) groove weld shall be as shown in Table 6.10.4.

The effective weld size for flare groove welds, when filled flush to the surface of a round bar, a 90° bend in a formed section, or rectangular HSS shall be as shown in Table 6.10.5, unless other effective throats are demonstrated by tests. The effective size of flare groove welds filled less than flush shall be as shown in Table 6.10.5, less the greatest perpendicular dimension measured from a line flush to the base metal surface to the weld surface.

Larger effective throat thicknesses than those in Table 6.10.5 are permitted, provided the fabricator can establish by qualification the consistent production of such larger effective throat thicknesses. Qualification shall consist of sectioning the weld normal to its axis, at mid-length and terminal ends. Such sectioning shall be made on a number of combinations of material sizes representative of the range to be used in the fabrication.

10.10.2.1.2 Limitations

The minimum effective throat thickness of a partial-joint-penetration groove weld shall not be less than the size required to transmit calculated forces nor the size shown in Table 6.10.6. Minimum weld size is determined by the thinner of the two parts joined.

10.10.2.2 Fillet welds

10.10.2.2.1 Effective area

The effective area of a fillet weld shall be the effective length multiplied by the effective throat. The effective throat of a fillet weld shall be the shortest distance from the root to the face of the diagrammatic weld. An increase in effective throat is permitted if consistent penetration beyond the root of the diagrammatic weld is demonstrated by tests using the production process and procedure variables.

For fillet welds in holes and slots, the effective length shall be the length of the centerline of the weld along the center of the plane through the throat. In the case of overlapping fillets, the effective area shall not exceed the nominal cross-sectional area of the hole or slot, in the plane of the faying surface.

10.10.2.2.2 Limitations

The minimum size of fillet welds shall be not less than the size required to transmit calculated forces nor the size as shown in Table 6.10.7. These provisions do not apply to fillet weld reinforcements of partial- or complete-joint-penetration groove welds.

Table 6.10.4: Effective Throat of Partial-Joint-Penetration Groove Welds

Welding Process	Welding Position F (flat), H (horiz.), V (vert.), OH (overhead)	Groove Type (AWS D1.1, Figure 3.3)	Effective Throat
Shielded Metal Arc (SMAW)	All	J or U Groove 60° V	Depth of Groove
Gas Metal Arc (GMAW)	All		
Flux Cored Arc (FCAW)			
Submerged Arc (SAW)	F	J or U Groove 60° Bevel or V	
Gas Metal Arc (GMAW)	F, H	45° Bevel	Depth of Groove
Flux Cored Arc (FCAW)			

Welding Process	Welding Position F (flat), H (horiz.), V (vert.), OH (overhead)	Groove Type (AWS D1.1, Figure 3.3)	Effective Throat
Shielded Metal Arc (SMAW)	All	45° Bevel	Depth of Groove Minus 3 mm
Gas Metal Arc (GMAW) Flux Cored Arc (FCAW)	V, OH	45° Bevel	Depth of Groove Minus 3 mm

Table 6.10.5: Effective Weld Sizes of Flare Groove Welds

Welding Process	Flare Bevel Groove ^[a]	Flare V-Groove
GMAW and FCAW-G	$\frac{5}{8}R$	$\frac{3}{4}R$
SMAW and FCAW-S	$\frac{5}{16}R$	$\frac{5}{8}R$
SAW	$\frac{5}{16}R$	$\frac{1}{2}R$

^[a] For Flare Bevel Groove with $R < 10$ mm use only reinforcing fillet weld on filled flush joint. General Note: R = radius of joint surface (can be assumed to be $2t$ for HSS), mm

Table 6.10.6: Minimum Effective Throat Thickness of Partial-Joint-Penetration Groove Welds

Material Thickness of Thinner Part Joined (mm)	Minimum Effective Throat Thickness, ^[a] (mm)
To 6 inclusive	3
Over 6 to 13	5
Over 13 to 19	6
Over 19 to 38	8
Over 38 to 57	10
Over 57 to 150	13
Over 150	16

^[a] See Table 6.10.4.

Table 6.10.7: Minimum Size of Fillet Welds

Material Thickness of Thinner Part Joined (mm)	Minimum Size of Fillet Weld,^[a] (mm)
To 6 inclusive	3
Over 6 to 13	5
Over 13 to 19	6
Over 19	8

[a] Leg dimension of fillet welds. Single pass welds must be used.

Note: See Sec 10.10.2.2.2 for maximum size of fillet welds.

The maximum size of fillet welds of connected parts shall be:

Along edges of material less than 6 mm thick, not greater than the thickness of the material.

Along edges of material 6 mm or more in thickness, not greater than the thickness of the material minus 2 mm, unless the weld is especially designated on the drawings to be built out to obtain full-throat thickness. In the as-welded condition, the distance between the edge of the base metal and the toe of the weld is permitted to be less than 2 mm provided the weld size is clearly verifiable.

The minimum effective length of fillet welds designed on the basis of strength shall be not less than four times the nominal size, or else the size of the weld shall be considered not to exceed 1/4th of its effective length. If longitudinal fillet welds are used alone in end connections of flat-bar tension members, the length of each fillet weld shall be not less than the perpendicular distance between them. For the effect of longitudinal fillet weld length in end connections upon the effective area of the connected member, see Sec 10.4.3.3.

For end-loaded fillet welds with a length up to 100 times the leg dimension, it is permitted to take the effective length equal to the actual length. When the length of the end-loaded fillet weld exceeds 100 times the weld size, the effective length shall be determined by multiplying the actual length by the reduction factor, β ,

$$\beta = 1.2 - 0.002(L/w) \leq 1.0 \quad (6.10.159)$$

Where,

L = actual length of end-loaded weld, mm

w = weld leg size, mm

When the length of the weld exceeds 300 times the leg size, the value of β shall be taken as 0.60.

Intermittent fillet welds are permitted to be used to transfer calculated stress across a joint or faying surfaces when the required strength is less than that developed by a continuous fillet weld of the smallest permitted size, and to join components of built-up members. The effective length of any segment of intermittent fillet welding shall be not less than four times the weld size, with a minimum of 38 mm.

In lap joints, the minimum amount of lap shall be five times the thickness of the thinner part joined, but not less than 25 mm. Lap joints joining plates or bars subjected to axial stress that utilize transverse fillet welds only shall be fillet welded along the end of both lapped parts, except where the deflection of the lapped parts is sufficiently restrained to prevent opening of the joint under maximum loading.

Fillet weld terminations are permitted to be stopped short or extend to the ends or sides of parts or be boxed except as limited by the following:

For lap joints in which one connected part extends beyond an edge of another connected part that is subject to calculated tensile stress, fillet welds shall terminate not less than the size of the weld from that edge.

For connections where flexibility of the outstanding elements is required, when end returns are used, the length of the return shall not exceed four times the nominal size of the weld nor half the width of the part.

Fillet welds joining transverse stiffeners to plate girder webs 19 mm thick or less shall end not less than four times nor more than six times the thickness of the web from the web toe of the web-to-flange welds, except where the ends of stiffeners are welded to the flange.

Fillet welds that occur on opposite sides of a common plane shall be interrupted at the corner common to both welds.

Fillet welds in holes or slots are permitted to be used to transmit shear in lap joints or to prevent the buckling or separation of lapped parts and to join components of built-up members. Such fillet welds may overlap, subject to the provisions of Sec 10.10.2. Fillet welds in holes or slots are not to be considered plug or *slot welds*.

10.10.2.3 Plug and slot welds

10.10.2.3.1 Effective area

The effective shearing area of plug and slot welds shall be considered as the nominal cross-sectional area of the hole or slot in the plane of the faying surface.

10.10.2.3.2 Limitations

Plug or slot welds are permitted to be used to transmit shear in lap joints or to prevent buckling of lapped parts and to join component parts of built-up members.

The diameter of the holes for a plug weld shall not be less than the thickness of the part containing it plus 8 mm, rounded to the next larger odd even mm, nor greater than the minimum diameter plus 3 mm or $2\frac{1}{4}$ times the thickness of the weld.

The minimum center-to-center spacing of plug welds shall be four times the diameter of the hole.

The length of slot for a slot weld shall not exceed 10 times the thickness of the weld. The width of the slot shall be not less than the thickness of the part containing it plus 8 mm rounded to the next larger odd even mm, nor shall it be larger than $2\frac{1}{4}$ times the thickness of the weld. The ends of the slot shall be semicircular or shall have the corners rounded to a radius of not less than the thickness of the part containing it, except those ends which extend to the edge of the part.

The minimum spacing of lines of slot welds in a direction transverse to their length shall be four times the width of the slot. The minimum center-to-center spacing in a longitudinal direction on any line shall be two times the length of the slot.

The thickness of plug or slot welds in material 16 mm or less in thickness shall be equal to the thickness of the material. In material over 16 mm thick, the thickness of the weld shall be at least one-half the thickness of the material but not less than 16 mm.

10.10.2.4 Strength

The design strength, ϕR_n and the allowable strength, R_n/Ω , of welds shall be the lower value of the base material and the weld metal strength determined according to the limit states of tensile rupture, shear rupture or yielding as follows:

Table 6.10.8: Available Strength of Welded Joints, N

Load Type and Direction Relative to Weld Axis	Pertinent Metal	ϕ and Ω	Nominal Strength (F_{BM} or F_W), N	Effective Area (A_{BM} or A_W), mm^2	Required Filler Metal Strength Level ^{[a][b]}
---	-----------------	---------------------	---	---	--

COMPLETE-JOINT-PENETRATION GROOVE WELDS

Tension Normal to weld axis	Strength of the joint is controlled by the base metal			Matching filler metal shall be used. For T and corner joints with backing left in place, notch tough filler metal is required. Sec 10.10.2.6.
Compression Normal to weld axis	Strength of the joint is controlled by the base metal			Filler metal with a strength level equal to or one strength level less than matching filler metal is permitted.
Tension or Compression Parallel to weld axis	Tension or compression in parts joined parallel to a weld need not be considered in design of welds joining the parts.			Filler metal with a strength level equal to or less than matching filler metal is permitted.
Shear	Strength of the joint is controlled by the base metal			Matching filler metal shall be used. ^[c]

PARTIAL-JOINT-PENETRATION GROOVE WELDS INCLUDING FLARE VEE GROOVE AND FLARE BEVEL GROOVE WELDS

Tension Normal to weld axis	Base	$\phi = 0.90$ $\Omega = 1.67$	F_y	See 10.10.4	Filler metal with a strength level equal to or less than matching filler metal is permitted.
	Weld	$\phi = 0.80$ $\Omega = 1.88$	$0.60 F_{EXX}$	See 10.10.2.1.1	

Load Type and Direction Relative to Weld Axis	Pertinent Metal	ϕ and Ω	Nominal Strength (F_{BM} or F_W), N	Effective Area (A_{BM} or A_W), mm^2	Required Filler Metal Strength Level ^{[a][b]}
Compression Column to Base Plate and column splices designed per 10.10.1.4(a)					Filler metal with a strength level equal to or less than matching filler metal is permitted.
Compression Connections of members designed to bear other than columns as described in 10.10.1.4(b)	Base	$\phi = 0.90$ $\Omega = 1.67$	F_y	See 10.10.4	
	Weld	$\phi = 0.80$ $\Omega = 1.88$	$0.60 F_{EXX}$	See 10.10.2.1.1	
Compression Connections not finished-to-bear	Base	$\phi = 0.90$ $\Omega = 1.67$	F_y	See 10.10.4	
	Weld	$\phi = 0.80$ $\Omega = 1.88$	$0.90 F_{EXX}$	See 10.10.2.1.1	
Tension or Compression Parallel to weld axis					
Shear	Base		Governed by 10.10.4		
	Weld	$\phi = 0.75$ $\Omega = 2.00$	$0.60 F_{EXX}$	See 10.10.2.1.1	

Load Type and Direction Relative to Weld Axis	Pertinent Metal	ϕ and Ω	Nominal Strength (F_{BM} or F_W), N	Effective Area (A_{BM} or A_W), mm^2	Required Filler Metal Strength Level ^{[a][b]}
FILLET WELDS INCLUDING FILLETS IN HOLES AND SLOTS AND SKEWED T-JOINTS					
Shear	Base	Governed by 10.10.4			Filler metal with a strength level equal to or less than matching filler metal is permitted.
	Weld	$\phi = 0.75$ $\Omega = 2.00$	$0.60F_{EXX}^{[d]}$	See 10.10.2.2.1	
Tension or Compression Parallel to weld axis	Tension or compression in parts joined parallel to a weld need not be considered in design of welds joining the parts.				
PLUG AND SLOT WELDS					
Shear Parallel to faying surface on the effective area	Base	Governed by 10.10.4			Filler metal with a strength level equal to or less than matching filler metal is permitted.
	Weld	$\phi = 0.75$ $\Omega = 2.00$	$0.60F_{EXX}^{[d]}$	10.10.2.3.1	

^[a] For matching weld metal see AWS D1.1, Section 3.3.

^[b] Filler metal with a strength level one strength level greater than matching is permitted.

^[c] Filler metals with a strength level less than matching may be used for groove welds between the webs and flanges of built-up sections transferring shear loads, or in applications where high restraint is a concern. In these applications, the weld joint shall be detailed and the weld shall be designed using the thickness of the material as the effective throat, $\phi = 0.80, \Omega = 1.88$ and $0.60 F_{EXX}$ as the nominal strength.

^[d] Alternatively, the provisions of Sec 10.10.2.4 (a) are permitted provided the deformation compatibility of the various weld elements is considered. Alternatively, Sections 10.10.2.4 (b) and (c) are special applications of Sec 10.10.2.4 (a) that provide for deformation compatibility.

For the base metal

$$R_n = F_{BM}A_{BM} \quad (6.10.160)$$

For the weld metal

$$R_n = F_w A_w \quad (6.10.161)$$

Where,

F_{BM} = nominal strength of the base metal per unit area, MPa

F_w = nominal strength of the weld metal per unit area, MPa

A_{BM} = cross-sectional area of the base metal, mm²

A_w = effective area of the weld, mm²

The values of ϕ , Ω , F_{BM} , and F_w and limitations thereon are given in Table 6.10.8.

Alternatively, for fillet welds loaded in-plane the design strength, ϕR_n and the allowable strength, R_n/Ω of welds is permitted to be determined as follows:

$$\phi = 0.75 \text{ (LRFD)} \quad \Omega = 2.00 \text{ (ASD)}$$

(a) For a linear weld group loaded in-plane through the center of gravity

$$R_n = F_w A_w \quad (6.10.162)$$

Where,

$$F_w = 0.60F_{EXX}(1.0 + 0.50\sin^{1.5}\theta) \quad (6.10.163)$$

And,

F_{EXX} = electrode classification number, MPa

θ = angle of loading measured from the weld longitudinal axis, degrees

A_w = effective area of the weld, mm²

- (b) For weld elements within a weld group that are loaded in-plane and analyzed using an instantaneous center of rotation method, the components of the nominal strength, R_{nx} and R_{ny} , are permitted to be determined as follows:

$$R_{nx} = \sum F_{wix}A_{wi} \quad R_{ny} = \sum F_{wiy}A_{wi} \quad (6.10.164)$$

Where,

A_{wi} = effective area of weld throat of any i^{th} weld element, mm^2

$$F_{wi} = 0.60F_{EXX}(1.0 + 0.50\sin^{1.5}\theta)f(p) \quad (6.10.165)$$

$$f(p) = [p(1.9 - 0.9p)]^{0.3} \quad (6.10.166)$$

F_{wi} = nominal stress in any i^{th} weld element, MPa

F_{wix} = x component of stress, F_{wi}

F_{wiy} = y component of stress, F_{wi}

$\rho = \frac{\Delta_i}{\Delta_m}$, ratio of element i deformation to its deformation at maximum stress

w = weld leg size, mm

r_{crit} = distance from instantaneous center of rotation to weld element with minimum Δ_u/r_i ratio, mm

Δ_l = deformation of weld elements at intermediate stress levels, linearly proportioned to the critical deformation based on distance from the instantaneous center of rotation, $r_i(\text{mm}) = \frac{r_i\Delta_u}{r_{crit}}$.

$\Delta_m = 0.209(\theta + 2)^{-0.32}w$ deformation of weld element at maximum stress, mm

$\Delta_u = 1.087(\theta + 6)^{-0.65}w \leq 0.17w$, deformation of weld element at ultimate stress (fracture), usually in element furthest from instantaneous center of rotation, mm

- (c) For fillet weld groups concentrically loaded and consisting of elements that are oriented both longitudinally and transversely to the direction of applied load, the combined strength, R_n , of the fillet weld group shall be determined as the greater of

$$R_n = R_{wl} + R_{wt} \quad (6.10.167a)$$

Or,

$$R_n = 0.85R_{wl} + 1.5R_{wt} \quad (6.10.167b)$$

Where,

R_{wl} = the total nominal strength of longitudinally loaded fillet welds, as determined in accordance with Table 6.10.8, N

R_{wt} = the total nominal strength of transversely loaded fillet welds, as determined in accordance with Table 6.10.8 without the alternate in Sec 10.10.2.4(a), N

10.10.2.5 Combination of welds

If two or more of the general types of welds (groove, fillet, plug, slot) are combined in a single *joint*, the strength of each shall be separately computed with reference to the axis of the group in order to determine the strength of the combination.

10.10.2.6 Filler metal requirements

The choice of electrode for use with complete-joint-penetration groove welds subject to tension normal to the effective area shall comply with the requirements for matching filler metals given in AWS D1.1.

Filler metal with a specified Charpy V-Notch (CVN) toughness of 27.12 N-m (27 Joule) at 4°C shall be used in the following joints:

Complete-joint-penetration groove welded T and corner joints with steel backing left in place, subject to tension normal to the effective area, unless the joints are designed using the nominal strength and resistance factor or safety factor as applicable for a PJP weld.

Complete-joint-penetration groove welded splices subject to tension normal to the effective area in heavy sections as defined in Sections 10.1.3.1(c) and 10.1.3.1(d).

10.10.2.7 Mixed weld metal

When Charpy V-Notch toughness is specified, the process consumables for all weld metal, tack welds, root pass and subsequent passes deposited in a joint shall be compatible to ensure notch-tough composite weld metal.

10.10.3 Bolts and Threaded Parts

10.10.3.1 High-strength bolts

Use of high-strength bolts shall conform to the provisions of the Specification for Structural Joints Using ASTM A325 or A490 Bolts, hereafter referred to as the RCSC Specification, as approved by the Research Council on Structural Connections, except as otherwise provided in this Specification.

When assembled, all joint surfaces, including those adjacent to the washers, shall be free of scale, except tight mill scale. All ASTM A325/A325M and A490/A490M bolts shall be tightened to a bolt tension not less than given in Table 6.10.9, except as noted below. Except as permitted below, installation shall be assured by any of the following methods: turn-of-nut method, a direct tension indicator, calibrated wrench or alternative design bolt.

- (a) Bolts are permitted to be installed to only the snug-tight condition when used in bearing-type connections.
- (b) Tension or combined shear and tension applications, for ASTM A325 or A325M bolts only, where loosening or fatigue due to vibration or load fluctuations are not design considerations.

Table 6.10.9: Minimum Bolt Pretension, kN*

Bolt Size, mm	A325M Bolts	A490M Bolts
M16	91	114
M20	142	179
M22	176	221
M24	205	257
M27	267	334
M30	326	408
M36	475	595

* Equal to 0.70 times the minimum tensile strength of bolts, rounded off to nearest kN, as specified in ASTM specifications for A325M and A490M bolts with UNC threads.

The snug-tight condition is defined as the tightness attained by either a few impacts of an impact wrench or the full effort of a worker with an ordinary spud wrench that brings the connected plies into firm contact. Bolts to be tightened only to the snug-tight condition shall be clearly identified on the design and erection drawings.

When ASTM A490 or A490M bolts over 25 mm in diameter are used in slotted or oversized holes in external plies, a single hardened washer conforming to ASTM F436, except with 8 mm minimum thickness, shall be used in lieu of the standard washer.

In slip-critical connections in which the direction of loading is toward an edge of a connected part, adequate available bearing strength shall be provided based upon the applicable requirements of Sec 10.10.3.10.

When bolt requirements cannot be provided by ASTM A325/A325M, F1852, or A490/A490M bolts because of requirements for lengths exceeding 12 diameters or diameters exceeding 38 mm, bolts or threaded rods conforming to ASTM A354 Grade BC, A354 Grade BD, or A449 are permitted to be used in accordance with the provisions for threaded rods in Table 6.10.10.

When ASTM A354 Grade BC, A354 Grade BD, or A449 bolts and threaded rods are used in slip-critical connections, the bolt geometry including the head and nut(s) shall be equal to or (if larger in diameter) proportional to that provided by ASTM A325/A325M, or ASTM A490/A490M bolts. Installation shall comply with all applicable requirements of the RCSC Specification with modifications as required for the increased diameter and/ or length to provide the design pretension.

10.10.3.2 Size and use of holes

The maximum sizes of holes for bolts are given in Table 6.10.11, except that larger holes, required for tolerance on location of anchor rods in concrete foundations, are permitted in column base details.

Standard holes or short-slotted holes transverse to the direction of the load shall be provided in accordance with the provisions of this specification, unless over-sized holes, short-slotted holes parallel to the load or long-slotted holes are approved by the engineer of record. Finger shims up to 6 mm are permitted in slip-critical connections designed on the basis of standard holes without reducing the nominal shear strength of the fastener to that specified for slotted holes.

Oversized holes are permitted in any or all plies of slip-critical connections, but they shall not be used in bearing-type connections. Hardened washers shall be installed over oversized holes in an outer ply.

Short-slotted holes are permitted in any or all plies of slip-critical or bearing-type connections. The slots are permitted without regard to direction of loading in slip-critical connections, but the length shall be normal to the direction of the load in bearing-type connections. Washers shall be installed over short-slotted holes in an outer ply; when high-strength bolts are used, such washers shall be hardened.

Long-slotted holes are permitted in only one of the connected parts of either a slip-critical or bearing-type connection at an individual faying surface. Long-slotted holes are permitted without regard to direction of loading in slip-critical connections, but shall be normal to the direction of load in bearing-type connections. Where long-slotted holes are

used in an outer ply, plate washers, or a continuous bar with standard holes, having a size sufficient to completely cover the slot after installation, shall be provided. In high-strength bolted connections, such plate washers or continuous bars shall be not less than 8 mm thick and shall be of structural grade material, but need not be hardened. If hardened washers are required for use of high-strength bolts, the hardened washers shall be placed over the outer surface of the plate washer or bar.

Table 6.10.10: Nominal Stress of Fasteners and Threaded Parts, MPa

Description of Fasteners	Nominal Tensile Stress, F_{nt} , MPa	Nominal Shear Stress in Bearing-Type Connections, F_{nv} , MPa
A307 bolts	310 [a][b]	165 [b][c][f]
A325/A325M bolts, when threads are not excluded from shear planes	620 [e]	330 [f]
A325/A325M bolts, when threads are excluded from shear planes	620 [e]	414 [f]
A490/A490M bolts, when threads are not excluded from shear planes	780 [e]	414 [f]
A490/A490M bolts, when threads are excluded from shear planes	780 [e]	520 [f]
Threaded parts meeting the requirements of Sec 10.1.3.4, when threads are not excluded from shear planes	$0.75 F_u$ [a][d]	$0.40 F_u$
Threaded parts meeting the requirements of Sec 10.1.3.4, when threads are excluded from shear planes	$0.75 F_u$ [a][d]	$0.50 F_u$

[a] Subject to the requirements of Sec 10.17.

[b] For A307 bolts the tabulated values shall be reduced by 1 percent for each 2 mm over 5 diameters of length in the grip.

[c] Threads permitted in shear planes.

[d] The nominal tensile strength of the threaded portion of an upset rod, based upon the cross-sectional area at its major thread diameter, AD, which shall be larger than the nominal body area of the rod before upsetting times F_y .

[e] For A325 or A325M and A490 or A490M bolts subject to tensile fatigue loading, see Sec 10.2.3.9

[f] When bearing-type connections used to splice tension members have a fastener pattern whose length, measured parallel to the line of force, exceeds 1270 mm, tabulated values shall be reduced by 20 percent.

Table 6.10.11: Nominal Hole Dimensions, mm

Bolt Diameter	Hole Dimensions			
	Standard (Diameter)	Oversize (Diameter)	Short-Slot (Width × Length)	Long-Slot (Width × Length)
M16	18	20	18 × 22	18 × 40
M20	22	24	22 × 26	22 × 50
M22	24	28	24 × 30	24 × 55
M24	27 [a]	30	27 × 32	27 × 60
M27	30	35	30 × 37	30 × 67
M30	33	38	33 × 40	33 × 75
≥M36	$d + 3$	$d + 8$	$(d + 3) \times (d + 10)$	$(d + 3) \times 2.5d$

^[a] Clearance provided allows the use of a 25 mm. bolt if desirable.

10.10.3.3 Minimum spacing

The distance between centers of standard, oversized, or slotted holes, shall not be less than $2\frac{2}{3}$ times the nominal diameter, d of the fastener; a distance of $3d$ is preferred.

10.10.3.4 Minimum edge distance

The distance from the center of a standard hole to an edge of a connected part in any direction shall not be less than either the applicable value from Table 6.10.12, or as required in Sec 10.10.3.10. The distance from the center of an oversized or slotted hole to an edge of a connected part shall be not less than that required for a standard hole to an edge of a connected part plus the applicable increment C_2 from Table 6.10.13.

Table 6.10.12: Minimum Edge Distance,^[a] mm, from Center of Standard Hole^[b] to Edge of Connected Part

Bolt Diameter (mm)	At Sheared Edges	At Rolled Edges of Plates, Shapes or Bars, or Thermally Cut Edges ^[c]
16	28	22
20	34	26
22	38 ^[d]	28
24	42 ^[d]	30
27	48	34

Bolt Diameter (mm)	At Sheared Edges	At Rolled Edges of
		Plates, Shapes or Bars, or Thermally Cut Edges ^[c]
30	52	38
36	64	46
Over 36	1.75d	1.25d

Notes: Table 6.10.12

^[a] Lesser edge distances are permitted to be used provided provisions of Sec 10.10.3.10, as appropriate, are satisfied.

^[b] For oversized or slotted holes, see Table 6.10.13.

^[c] All edge distances in this column are permitted to be reduced 3 mm when the hole is at a point where required strength does not exceed 25 percent of the maximum strength in the element.

^[d] These are permitted to be 32 mm at the ends of beam connection angles and shear end plates.

Table 6.10.13: Values of Edge Distance Increment C_2 , mm

Nominal Diameter of Fastener(mm)	Oversized Holes	Slotted Holes		
		Long Axis Perpendicular to Edge		Long Axis Parallel to Edge
		Short Slots	Long Slots ^[a]	
≤ 22	2	3	0.75d	0
24	3	3		
≥ 27	3	5		

^[a] When length of slot is less than maximum allowable (see Table 6.10.11). C_2 is permitted to be reduced by one-half the difference between the maximum and actual slot lengths.

10.10.3.5 Maximum spacing and edge distance

The maximum distance from the center of any bolt or rivet to the nearest edge of parts in contact shall be 12 times the thickness of the connected part under consideration, but shall not exceed 150 mm. The longitudinal spacing of fasteners between elements in continuous contact consisting of a plate and a shape or two plates shall be as follows:

- For painted members or unpainted members not subject to corrosion, the spacing shall not exceed 24 times the thickness of the thinner plate or 305 mm.
- For unpainted members of weathering steel subject to atmospheric corrosion, the spacing shall not exceed 14 times the thickness of the thinner plate or 180 mm.

10.10.3.6 Tension and shear strength of bolts and threaded parts

The design tension or shear strength, ϕR_n and the allowable tension or shear strength, R_n/Ω , of a snug-tightened or pretensioned high-strength bolt or threaded part shall be determined according to the limit states of tensile rupture and shear rupture as follows:

$$R_n = F_n A_b \quad (6.10.168)$$

$$\phi = 0.75 \text{ (LRFD)} \quad \Omega = 2.00 \text{ (ASD)}$$

Where,

F_n = nominal tensile stress F_{nt} , or shear stress, F_{nv} from Table 6.10.10, MPa

A_b = nominal unthreaded body area of bolt or threaded part (for upset rods, see footnote d, Table 6.10.10, mm²)

The required tensile strength shall include any tension resulting from prying action produced by deformation of the connected parts.

10.10.3.7 Combined tension and shear in bearing-type connection

The available tensile strength of a bolt subjected to combined tension and shear shall be determined according to the limit states of tension and shear rupture as follows:

$$R_n = F'_{nt} A_b \quad (6.10.169)$$

$$\phi = 0.75 \text{ (LRFD)} \quad \Omega = 2.00 \text{ (ASD)}$$

Where,

F'_{nt} = nominal tensile stress modified to include the effects of shearing stress, MPa

$$F'_{nt} = 1.3F_{nt} - \frac{F_{nt}}{\phi F_{nv}} f_v \leq F_{nt} \text{ (LRFD)} \quad (6.10.170a)$$

$$F'_{nt} = 1.3F_{nt} - \frac{\Omega F_{nt}}{\phi F_{nv}} f_v \leq F_{nt} \text{ (ASD)} \quad (6.10.170b)$$

F_{nt} = nominal tensile stress from Table 6.10.10, MPa

F_{nv} = nominal shear stress from Table 6.10.10, MPa

f_v = the required shear stress, MPa

The available shear stress of the fastener shall equal or exceed the required shear strength per unit area, f_v .

10.10.3.8 High-strength bolts in slip-critical connections

High-strength bolts in slip-critical connections are permitted to be designed to prevent slip either as a serviceability limit state or at the required strength limit state. The connection must also be checked for shear strength in accordance with Sections 10.10.3.6 and 10.10.3.7 and bearing strength in accordance with Sections 10.10.3.1 and 10.10.3.10.

Slip-critical connections shall be designed as follows, unless otherwise designated by the engineer of record. Connections with standard holes or slots transverse to the direction of the load shall be designed for slip as a serviceability limit state. Connections with oversized holes or slots parallel to the direction of the load shall be designed to prevent slip at the required strength level.

The design slip resistance, ϕR_n and the allowable slip resistance, $\frac{R_n}{\Omega}$ shall be determined for the limit state of slip as follows:

$$R_n = \mu D_u h_{sc} T_b N_s \quad (6.10.171)$$

For connections in which prevention of slip is a serviceability limit state

$$\phi = 1.00 \text{ (LRFD)} \quad \Omega = 1.50 \text{ (ASD)}$$

For connections designed to prevent slip at the required strength level

$$\phi = 0.85 \text{ (LRFD)} \quad \Omega = 1.76 \text{ (ASD)}$$

Where,

μ = mean slip coefficient for Class A or B surfaces, as applicable, or as established by tests

= 0.35 for Class A surfaces (unpainted clean mill scale steel surfaces or surfaces with Class A coatings on blast-cleaned steel and hot-dipped galvanized and roughened surfaces)

= 0.50 for Class B surfaces (unpainted blast-cleaned steel surfaces or surfaces with Class B coatings on blast-cleaned steel)

$D_u = 1.13$; a multiplier that reflects the ratio of the mean installed bolt pretension to the specified minimum bolt pretension. The use of other values may be approved by the engineer of record.

h_{sc} = hole factor determined as follows:

- (a) For standard size holes $h_{sc} = 1.00$
- (b) For oversized and short-slotted holes $h_{sc} = 0.85$
- (c) For long-slotted holes $h_{sc} = 0.70$

N_s = number of slip planes

T_b = minimum fastener tension given in Table 6.10.9, kN

10.10.3.9 Combined tension and shear in slip-critical connections

When a slip-critical connection is subjected to an applied tension that reduces the net clamping force, the available slip resistance per bolt, from Sec 10.10.3.8, shall be multiplied by the factor, k_s , as follows:

$$k_s = 1 - \frac{T_u}{D_u T_b N_b} \quad (\text{LRFD}) \quad (6.10.172a)$$

$$k_s = 1 - \frac{1.5T_a}{D_u T_b N_b} \quad (\text{ASD}) \quad (6.10.172b)$$

Where,

N_b = number of bolts carrying the applied tension

T_a = tension force due to ASD load combinations, kN

T_b = minimum fastener tension given in Table 6.10.9, kN

T_u = tension force due to LRFD load combinations, kN

10.10.3.10 Bearing strength at bolt holes

The available bearing strength, ϕR_n and R_n/Ω , at bolt holes shall be determined for the limit state of bearing as follows:

$$\phi = 0.75 \quad (\text{LRFD}) \quad \Omega = 2.00 \quad (\text{ASD})$$

For a bolt in a connection with standard, oversized, and short-slotted holes, independent of the direction of loading, or a long-slotted hole with the slot parallel to the direction of the bearing force:

- (a) When deformation at the bolt hole at service load is a design consideration

$$R_n = 1.2L_c t F_u \leq 2.4dt F_u \quad (6.10.173a)$$

- (b) When deformation at the bolt hole at service load is not a design consideration

$$R_n = 1.5L_c t F_u \leq 3.0dt F_u \quad (6.10.173b)$$

For a bolt in a connection with long-slotted holes with the slot perpendicular to the direction of force:

$$R_n = 1.0L_c t F_u \leq 2.0dt F_u \quad (6.10.173c)$$

For connections made using bolts that pass completely through an unstiffened box member or *HSS* see Sec 10.10.7 and Eq. 6.10.180,

Where,

d = nominal bolt diameter, mm

F_u = specified minimum tensile strength of the connected material, MPa

L_c = clear distance, in the direction of the force, between the edge of the hole and the edge of the adjacent hole or edge of the material, mm

t = thickness of connected material, mm

For connections, the bearing resistance shall be taken as the sum of the bearing resistances of the individual bolts.

Bearing strength shall be checked for both bearing-type and slip-critical connections. The use of oversized holes and short- and long-slotted holes parallel to the line of force is restricted to slip-critical connections per Sec 10.10.3.2.

10.10.3.11 Special fasteners

The nominal strength of special fasteners other than the bolts presented in Table 6.10.10 shall be verified by tests.

10.10.3.12 Tension fasteners

When bolts or other fasteners in tension are attached to an unstiffened box or *HSS* wall, the strength of the wall shall be determined by rational analysis.

10.10.4 Affected Elements of Members and Connecting Elements

This Section applies to elements of members at connections and connecting elements, such as plates, gussets, angles, and brackets.

10.10.4.1 Strength of elements in tension

The design strength, ϕR_n and the allowable strength, R_n/Ω , of affected and connecting elements loaded in tension shall be the lower value obtained according to the limit states of tensile yielding and tensile rupture.

For tensile yielding of connecting elements:

$$R_n = F_y A_g \quad (6.10.174)$$

$$\phi = 0.90 \text{ (LRFD)} \quad \Omega = 1.67 \text{ (ASD)}$$

For tensile rupture of connecting elements:

$$R_n = F_u A_e \quad (6.10.175)$$

$$\phi = 0.75 \text{ (LRFD)} \quad \Omega = 2.00 \text{ (ASD)}$$

Where,

A_e = effective net area as defined in Sec 10.4.3.3, mm²; for bolted splice plates, $A_e = A_n \leq 0.85 A_g$

10.10.4.2 Strength of elements in shear

The available shear yield strength of affected and connecting elements in shear shall be the lower value obtained according to the limit states of shear yielding and shear rupture:

For shear yielding of the element:

$$R_n = 0.60 F_y A_g \quad (6.10.176)$$

$$\phi = 1.00 \text{ (LRFD)} \quad \Omega = 1.50 \text{ (ASD)}$$

For shear rupture of the element:

$$R_n = 0.60F_u A_{nv} \quad (6.10.177)$$

$$\phi = 0.75 \text{ (LRFD)} \quad \Omega = 2.00 \text{ (ASD)}$$

Where,

$$A_{nv} = \text{net area subject to shear, mm}^2$$

10.10.4.3 Block shear strength

The available strength for the limit state of block shear rupture along a shear failure path or path(s) and a perpendicular tension failure path shall be taken as

$$R_n = 0.60F_u A_{nv} + U_{bs} F_u A_{nt} \leq 0.6F_y A_{gv} + U_{bs} F_u A_{nt} \quad (6.10.178)$$

$$\phi = 0.75 \text{ (LRFD)} \quad \Omega = 2.00 \text{ (ASD)}$$

Where,

$$A_{gv} = \text{gross area subject to shear, mm}^2$$

$$A_{nt} = \text{net area subject to tension, mm}^2$$

$$A_{nv} = \text{net area subject to shear, mm}^2$$

Where, the tension *stress* is uniform, $U_{bs} = 1$; where the tension stress is non-uniform, $U_{bs} = 0.5$.

10.10.4.4 Strength of elements in compression

The available strength of connecting elements in compression for the limit states of yielding and buckling shall be determined as follows.

For $KL/r \leq 25$

$$P_n = F_y A_g \quad (6.10.179)$$

$$\phi = 0.90 \text{ (LRFD)} \quad \Omega = 1.67 \text{ (ASD)}$$

For $KL/r > 25$ the provisions of Sec 10.5 apply.

10.10.5 Fillers

In welded construction, any filler 6 mm or more in thickness shall extend beyond the edges of the splice plate and shall be welded to the part on which it is fitted with sufficient weld to transmit the splice plate load, applied at the surface of the filler. The welds joining the splice plate to the filler shall be sufficient to transmit the splice plate load and shall be long enough to avoid overloading the filler along the toe of the weld. Any filler less than 6 mm thick shall have its edges made flush with the edges of the splice plate and the weld size shall be the sum of the size necessary to carry the splice plus the thickness of the filler plate.

When a bolt that carries load passes through fillers that are equal to or less than 6 mm thick, the shear strength shall be used without reduction. When a bolt that carries load passes through fillers that are greater than 6 mm thick, one of the following requirements shall apply:

For fillers that are equal to or less than 19 mm thick, the shear strength of the bolts shall be multiplied by the factor $[1 - 0.0154(t - 6)]$, where t is the total thickness of the fillers up to 19 mm;

The fillers shall be extended beyond the joint and the filler extension shall be secured with enough bolts to uniformly distribute the total force in the connected element over the combined cross section of the connected element and the fillers;

The size of the joint shall be increased to accommodate a number of bolts that is equivalent to the total number required in (2) above; or

The joint shall be designed to prevent slip at required strength levels in accordance with Sec 10.10.3.8.

10.10.6 Splices

Groove-welded splices in plate girders and beams shall develop the nominal strength of the smaller spliced section. Other types of splices in cross sections of plate girders and beams shall develop the strength required by the forces at the point of the splice.

10.10.7 Bearing Strength

The design bearing strength, ϕR_n and the allowable bearing strength, R_n/Ω , of surfaces in contact shall be determined for the limit state of bearing (local compressive yielding) as follows:

$$\phi = 0.75 \text{ (LRFD)} \quad \Omega = 2.00 \text{ (ASD)}$$

The nominal bearing strength, R_n , is defined as follows for the various types of bearing:

For milled surfaces, pins in reamed, drilled, or bored holes, and ends of fitted bearing stiffeners:

$$R_n = 1.8F_y A_{pb} \quad (6.10.180)$$

Where,

F_y = specified minimum yield stress, MPa

A_{pb} = projected bearing area, mm²

For expansion rollers and rockers:

If $d \leq 635$ mm

$$R_n = 1.2(F_y - 90)ld/20 \quad (6.10.181)$$

If $d > 635$ mm

$$R_n = 30.2(F_y - 90)l\sqrt{d}/20 \quad (6.10.182)$$

Where,

d = diameter, mm

l = length of bearing, mm

10.10.8 Column Bases and Bearing on Concrete

Proper provision shall be made to transfer the column loads and moments to the footings and foundations.

In the absence of the Code regulations, the design bearing strength, $\phi_c P_n$ and the allowable bearing strength, $\frac{P_n}{\Omega_c}$ for the limit state of concrete crushing are permitted to be taken as follows:

$$\phi_c = 0.60 \text{ (LRFD)} \quad \Omega_c = 2.50 \text{ (ASD)}$$

The nominal bearing strength, P_p , is determined as follows:

On the full area of a concrete support:

$$P_p = 0.8f'_c A_1 \quad (6.10.183)$$

On less than the full area of a concrete support:

$$P_p = 0.8f'_c A_1 \sqrt{A_2/A_1} \leq 1.7f'_c A_1 \quad (6.10.184)$$

Where,

A_1 = area of steel concentrically bearing on a concrete support, mm²

A_2 = maximum area of the portion of the supporting surface that is geometrically similar to and concentric with the loaded area, mm²

10.10.9 Anchor Rods and Embedments

Anchor rods shall be designed to provide the required resistance to loads on the completed structure at the base of columns including the net tensile components of any bending moment that may result from load combinations stipulated in Sec 10.2.2. The anchor rods shall be designed in accordance with the requirements for threaded parts in Table 6.10.10.

Larger oversized and slotted holes are permitted in base plates when adequate bearing is provided for the nut by using structural or plate washers to bridge the hole.

When horizontal forces are present at column bases, these forces should, where possible, be resisted by bearing against concrete elements or by shear friction between the column base plate and the foundation. When anchor rods are designed to resist horizontal force the base plate hole size, the anchor rod setting tolerance, and the horizontal movement of the column shall be considered in the design.

10.10.10 Flanges and Webs with Concentrated Forces

This Section applies to single- and double-concentrated forces applied normal to the flange(s) of wide flange sections and similar built-up shapes. A single- concentrated force can be either tensile or compressive. Double-concentrated forces are one tensile and one compressive and form a couple on the same side of the loaded member.

When the required strength exceeds the available strength as determined for the limit states listed in this Section, stiffeners and/or doublers shall be provided and shall be sized for the difference between the required strength and the available strength for the applicable limit state. Stiffeners shall also meet the design requirements in Sec 10.10.10.8. Doublers shall also meet the design requirement in Sec 10.10.10.9.

Stiffeners are required at unframed ends of beams in accordance with the requirements of Sec 10.10.10.7.

10.10.10.1 Flange local bending

This Section applies to tensile single-concentrated forces and the tensile component of double-concentrated forces.

The design strength, ϕR_n and the allowable strength, R_n/Ω , for the limit state of flange local bending shall be determined as follows:

$$R_n = 6.25t_f^2 F_{yf} \quad (6.10.185)$$

$$\phi = 0.90 \text{ (LRFD)} \quad \Omega = 1.67 \text{ (ASD)}$$

Where,

F_{yf} = specified minimum yield stress of the flange, MPa

t_f = thickness of the loaded flange, mm

If the length of loading across the member flange is less than $0.15b_f$, where b_f is the member flange width, Eq. 6.10.185 need not be checked.

The value of R_n shall be reduced by 50 percent, when the concentrated force to be resisted is applied at a distance from the member end that is less than $10t_f$.

When required, a pair of transverse stiffeners shall be provided.

10.10.10.2 Web local yielding

This Section applies to single-concentrated forces and both components of double-concentrated forces.

The available strength for the limit state of web local yielding shall be determined as follows:

$$\phi = 1.00 \text{ (LRFD)} \quad \Omega = 1.50 \text{ (ASD)}$$

The nominal strength, R_n shall be determined as follows:

When the concentrated force to be resisted is applied at a distance from the member end that is greater than the depth of the member d

$$R_n = (5k + N)F_{yw}t_w \quad (6.10.186)$$

When the concentrated force to be resisted is applied at a distance from the member end that is less than or equal to the depth of the member d ,

$$R_n = (2.5k + N)F_{yw}t_w \quad (6.10.187)$$

Where,

k = distance from outer face of the flange to the web toe of the fillet, mm

F_{yw} = specified minimum yield stress of the web, MPa

N = length of bearing (not less than k for end beam reactions), mm

t_w = web thickness, mm

When required, a pair of transverse stiffeners or a doubler plate shall be provided.

10.10.10.3 Web Crippling

This Section applies to compressive single-concentrated forces or the compressive component of double-concentrated forces.

The available strength for the limit state of web local crippling shall be determined as follows:

$$\phi = 0.75 \text{ (LRFD)} \quad \Omega = 2.00 \text{ (ASD)}$$

The nominal strength, R_n shall be determined as follows:

When the concentrated compressive force to be resisted is applied at a distance from the member end that is greater than or equal to $d/2$:

$$R_n = 0.80t_w^2 \left[1 + 3 \left(\frac{N}{d} \right) \left(\frac{t_w}{t_f} \right)^{1.5} \right] \sqrt{\frac{EF_{yw}t_f}{t_w}} \quad (6.10.188)$$

When the concentrated compressive force to be resisted is applied at a distance from the member end that is less than $d/2$:

For $N/d \leq 0.2$

$$R_n = 0.40t_w^2 \left[1 + 3 \left(\frac{N}{d} \right) \left(\frac{t_w}{t_f} \right)^{1.5} \right] \sqrt{\frac{EF_{yw}t_f}{t_w}} \quad (6.10.189a)$$

For $N/d > 0.2$

$$R_n = 0.40t_w^2 \left[1 + \left(\frac{4N}{d} - 0.2 \right) \left(\frac{t_w}{t_f} \right)^{1.5} \right] \sqrt{\frac{EF_{yw}t_f}{t_w}} \quad (6.10.189b)$$

Where,

d = overall depth of the member, mm

t_f = flange thickness, mm

When required, a transverse stiffener or pair of transverse stiffeners, or a doubler plate extending at least one-half the depth of the web shall be provided.

10.10.10.4 Web sidesway buckling

This Section applies only to compressive single-concentrated forces applied to members where relative lateral movement between the loaded compression flange and the tension flange is not restrained at the point of application of the concentrated force.

The available strength of the web shall be determined as follows:

$$\phi = 0.85 \text{ (LRFD)} \quad \Omega = 1.76 \text{ (ASD)}$$

The nominal strength, R_n for the limit state of web sidesway buckling shall be determined as follows:

If the compression flange is restrained against rotation:

For $(h/t_w)/(l/b_f) \leq 2.3$

$$R_n = \frac{C_r t_w^3 t_f}{h^2} \left[1 + 0.4 \left(\frac{h/t_w}{l/b_f} \right)^3 \right] \quad (6.10.190)$$

For $(h/t_w)/(l/b_f) > 2.3$, the limit state of web sidesway buckling does not apply.

When the required strength of the web exceeds the available strength, local lateral bracing shall be provided at the tension flange or either a pair of transverse stiffeners or a doubler plate shall be provided.

If the compression flange is not restrained against rotation

For $(h/t_w)/(l/b_f) \leq 1.7$

$$R_n = \frac{C_r t_w^3 t_f}{h^2} \left[0.4 \left(\frac{h/t_w}{l/b_f} \right)^3 \right] \quad (6.10.191)$$

For $(h/t_w)/(l/b_f) > 1.7$ the limit state of web sidesway buckling does not apply.

When the required strength of the web exceeds the available strength, local lateral bracing shall be provided at both flanges at the point of application of the concentrated forces.

In Equations 6.10.190 and 6.10.191, the following definitions apply:

b_f = flange width, mm

C_r = 6.62×10^6 MPa when $M_u < M_y$ (LRFD) or $1.5 M_a < M_y$ (ASD) at the location of the force

= 3.31×10^6 MPa when $M_u \geq M_y$ (LRFD) or $1.5 M_a \geq M_y$ (ASD) at the location of the force

h = clear distance between flanges less fillet or corner radius for rolled shapes; distance between adjacent lines of fasteners or clear distance between flanges when welds are used for built-up shapes, mm

l = largest laterally unbraced length along either flange at the point of load, mm

t_f = flange thickness, mm

t_w = web thickness, mm

10.10.10.5 Web compression buckling

This Section applies to a pair of compressive single-concentrated forces or the compressive components in a pair of double-concentrated forces, applied at both flanges of a member at the same location.

The available strength for the limit state of web local buckling shall be determined as follows:

$$R_n = \frac{24t_w^3 \sqrt{EF_{yw}}}{h} \quad (6.10.192)$$

$$\phi = 0.90 \text{ (LRFD)} \quad \Omega = 1.67 \text{ (ASD)}$$

When the pair of concentrated compressive forces to be resisted is applied at a distance from the member end that is less than $d/2$, R_n shall be reduced by 50 percent.

When required, a single transverse stiffener, a pair of transverse stiffeners, or a doubler plate extending the full depth of the web shall be provided.

10.10.10.6 Web panel zone shear

This Section applies to double-concentrated forces applied to one or both flanges of a member at the same location. The available strength of web panel zone for limit state of shear yielding shall be determined as follows:

$$\phi = 0.90 \text{ (LRFD)} \quad \Omega = 1.67 \text{ (ASD)}$$

The nominal strength, R_n , shall be determined as follows:

When the effect of panel-zone deformation on frame stability is not considered in the analysis:

For $P_r \leq 0.4P_c$

$$R_n = 0.60F_y d_c t_w \quad (6.10.193)$$

For $P_r > 0.4P_c$

$$R_n = 0.60F_y d_c t_w \left(1.4 - \frac{P_r}{P_c}\right) \quad (6.10.194)$$

When frame stability, including plastic panel-zone deformation, is considered in the analysis:

For $P_r \leq 0.75P_c$

$$R_n = 0.60F_y d_c t_w \left(1 + \frac{3b_{cf} t_{cf}^2}{d_b d_c t_w} \right) \quad (6.10.195)$$

For $P_r > 0.75P_c$

$$R_n = 0.60F_y d_c t_w \left(1 + \frac{3b_{cf} t_{cf}^2}{d_b d_c t_w} \right) \left(1.9 - \frac{1.2P_r}{P_c} \right) \quad (6.10.196)$$

In Equations 6.10.193 to 6.10.196, the following definitions apply:

- A = column cross-sectional area, mm²
- b_{cf} = width of column flange, mm
- d_b = beam depth, mm
- d_c = column depth, mm
- F_y = specified minimum yield stress of the column web, MPa
- P_c = P_y , N (LRFD)
- P_c = $0.6 P_y$, N (ASD)
- P_r = required strength, N
- P_y = $F_y A$, axial yield strength of the column, N
- t_{cf} = thickness of the column flange, mm
- t_w = column web thickness, mm

When required, doubler plate(s) or a pair of diagonal stiffeners shall be provided within the boundaries of the rigid connection whose webs lie in a common plane. See Sec 10.10.10.9 for doubler plate design requirements.

10.10.10.7 Unframed ends of beams and girders

At unframed ends of beams and girders not otherwise restrained against rotation about their longitudinal axes, a pair of transverse stiffeners, extending the full depth of the web, shall be provided.

10.10.10.8 Additional stiffeners requirements for concentrated forces

Stiffeners required to resist tensile concentrated forces shall be designed in accordance with the requirements of Sec 10.4 and welded to the loaded flange and the web. The welds to the flange shall be sized for the difference between the required strength and available limit state strength. The stiffener to web welds shall be sized to transfer to the web the algebraic difference in tensile force at the ends of the stiffener.

Stiffeners required to resist compressive concentrated forces shall be designed in accordance with the requirements in Sections 10.5.6.2 and 10.10.4.4 and shall either bear on or be welded to the loaded flange and welded to the web. The welds to the flange shall be sized for the difference between the required strength and the applicable limit state strength. The weld to the web shall be sized to transfer to the web the algebraic difference in compression force at the ends of the stiffener. For fitted bearing stiffeners, see Sec 10.10.7.

Transverse full depth bearing stiffeners for compressive forces applied to a beam or plate girder flange(s) shall be designed as axially compressed members (columns) as per the requirements of Sections 10.5.6.2 and 10.10.4.4.

The member properties shall be determined using an effective length of $0.75h$ and a cross section composed of two stiffeners and a strip of the web having a width of $25t_w$ at interior stiffeners and $12t_w$ at the ends of members. The weld connecting full depth bearing stiffeners to the web shall be sized to transmit the difference in compressive force at each of the stiffeners to the web.

Transverse and diagonal stiffeners shall comply with the following additional criteria:

The width of each stiffener plus one-half the thickness of the column web shall not be less than one-third of the width of the flange or moment connection plate delivering the concentrated force.

- (a) Thickness of a stiffener shall not be less than one-half the thickness of the flange or moment connection plate delivering the concentrated load, and greater than or equal to the width divided by 15.

- (b) Transverse stiffeners shall extend a minimum of one-half the depth of the member except as required in Sec. 10.10.10.5 and 10.10.10.7.

10.10.10.9 Additional doubler plate requirements for concentrated forces

Doubler plates required for compression strength shall be designed according to the requirements of Sec 10.5.

Doubler plates required for tensile strength shall be designed in accordance with the requirements of Sec 10.4.

Doubler plates required for shear strength (Sec 10.10.10.6) shall be designed following the provisions of Sec 10.7.

In addition, doubler plates shall comply with the following criteria:

- (a) The thickness and extent of the doubler plate shall provide the additional material necessary to equal or exceed the strength requirements.
- (b) The doubler plate shall be welded to develop the proportion of total force transmitted to doubler plate.

10.11 Design of Hss and Box Member Connections

This Section covers member strength design considerations pertaining to connections to HSS members and box sections of uniform wall thickness. See also Section 10.10 for additional requirements for bolting to HSS.

10.11.1 Concentrated Forces on HSS

10.11.1.1 Notation and definitions

The notation and their definitions related to this Section are given in Sec 10.1.2.

10.11.1.2 Limits of applicability

The criteria herein are applicable only when the connection configuration is within the following limits of applicability.

For HSS:

$$\text{Strength: } F_y \leq 360 \text{ MPa}$$

$$\text{Ductility: } \frac{F_y}{F_u} \leq 0.8$$

Other limits apply for specific criteria.

10.11.1.3 Concentrated force distributed transversely

10.11.1.3.1 Criterion for round HSS

When a concentrated force is distributed transversely to the axis of the HSS the design strength, ϕR_n and the allowable strength, R_n/Ω , for the limit state of local yielding shall be determined as follows:

$$R_n = F_y t^2 [5.5/(1 - 0.81B_p/D)] Q_f \quad (6.10.197)$$

$$\phi = 0.90 \text{ (LRFD)} \quad \Omega = 1.67 \text{ (ASD)}$$

Where, the Equations for Q_f is given in Sec 10.11.2.2 (Eq. 6.10.209).

Additional limits of applicability are:

$$0.2 < B_p/D \leq 1.0.$$

$$\text{For T-connections: } D/t \leq 50$$

$$\text{For cross-connections: } D/t \leq 40$$

10.11.1.3.2 Criterion for rectangular HSS

When a concentrated force is distributed transversely to the axis of the HSS the design strength, ϕR_n and the allowable strength, R_n/Ω , shall be the lowest value according to the limit states of local yielding due to uneven load distribution, shear yielding (punching) and sidewall strength.

Additional limits of applicability are:

$$0.25 < B_p/B \leq 1.0$$

$$\text{For loaded HSS wall } B/t \leq 35$$

For the limit state of local yielding due to uneven load distribution in the loaded plate,

$$R_n = \left[\frac{10}{\frac{F_y t}{\left(\frac{B}{t}\right)}} \right] B_p \leq F_{yp} t_p B_p \quad (6.10.198)$$

$$\phi = 0.95 \text{ (LRFD)} \quad \Omega = 1.58 \text{ (ASD)}$$

For the limit state of shear yielding (punching),

$$R_n = 0.6 F_y t [2t_p + 2B_{ep}] \quad (6.10.199)$$

$$\phi = 0.95 \text{ (LRFD)} \quad \Omega = 1.58 \text{ (ASD)}$$

Where, $B_{ep} = 10B_p / (B/t) \leq B_p$

This limit state need not be checked when $B_p > (B - 2t)$, nor when $B_p < 0.85B$.

For the limit state of sidewall under tension loading, the available strength shall be taken as the strength for sidewall local yielding. For the limit state of sidewall under compression loading, available strength shall be taken as the lowest value obtained according to the limit states of sidewall local yielding, sidewall local crippling and sidewall local buckling.

This limit state need not be checked unless the chord member and branch member (connecting element) have the same width ($\beta = 1.0$).

For the limit state of sidewall local yielding,

$$R_n = 2F_y t [5k + N] \quad (6.10.200)$$

$$\phi = 1.0 \text{ (LRFD)} \quad \Omega = 1.50 \text{ (ASD)}$$

Where, k = outside corner radius of the HSS, which is permitted to be taken as $1.5t$ if unknown, mm.

For the limit state of sidewall local crippling, in T-connections,

$$R_n = 1.6t^2 \left[1 + \frac{3N}{(H-3t)} \right] (EF_y)^{0.5} Q_f \quad (6.10.201)$$

$$\phi = 0.75 \text{ (LRFD)} \quad \Omega = 2.0 \text{ (ASD)}$$

Where, the Equations for Q_f is given in Sec 10.11.2.3 (Eq. 6.10.218).

For the limit state of sidewall local buckling in cross-connections,

$$R_n = \left[\frac{48t^3}{(H-3t)} \right] (EF_y)^{0.5} Q_f \quad (6.10.202)$$

$$\phi = 0.90 \text{ (LRFD)} \quad \Omega = 1.67 \text{ (ASD)}$$

Where, the Equations for Q_f is given in Sec 10.11.2.3 (Eq. 6.10.218).

The nonuniformity of load transfer along the line of weld, due to the flexibility of the HSS wall in a transverse plate-to-HSS connection, shall be considered in proportioning such welds. This requirement can be satisfied by limiting the total effective weld length, L_e , of groove and fillet welds to rectangular HSS as follows:

$$L_e = 2 \left[\frac{10}{\left(\frac{B}{t}\right)} \right] \left[\frac{(F_t t)}{(F_{yp} t_p)} \right] B_p \leq 2B_p \quad (6.10.203)$$

Where, L_e = total effective weld length for welds on both sides of the transverse plate, mm.

In lieu of Eq. 6.10.203, this requirement may be satisfied by other rational approaches.

10.11.1.4 Concentrated Force distributed longitudinally at the center of the HSS diameter or width and acting perpendicular to the HSS Axis

When a concentrated force is distributed longitudinally along the axis of the HSS at the center of the HSS diameter or width, and also acts perpendicular to the axis direction of the HSS (or has a component perpendicular to the axis direction of the HSS), the design strength, ϕR_n and the allowable strength, R_n/Ω , perpendicular to the HSS axis shall be determined for the limit state of chord plastification as follows.

10.11.1.4.1 Criterion for round HSS

An additional limit of applicability is:

$D/t \leq 50$ for T-connections and $D/t \leq 40$ for cross-connections

$$R_n = 5.5F_y t^2 \left(1 + \frac{0.25N}{D} \right) Q_f \quad (6.10.204)$$

$$\phi = 0.90 \text{ (LRFD)} \quad \Omega = 1.67 \text{ (ASD)}$$

Where, the Equation for Q_f is given in Sec 10.11.2.2 (Eq. 6.10.209).

10.11.1.4.2 Criterion for rectangular HSS

An additional limit of applicability is:

B/t for the loaded HSS wall ≤ 40

$$R_n = \left[\frac{F_y t^2}{(1-t_p/B)} \right] \left[\frac{2N}{B} + 4 \left(1 - \frac{t_p}{B} \right)^{0.5} Q_f \right] \quad (6.10.205)$$

$$\phi = 1.00 \text{ (LRFD)} \quad \Omega = 1.50 \text{ (ASD)}$$

Where, $Q_f = (1 - U^2)^{0.5}$

The Equation for U is given in Sec 10.11.2.3 (Eq. 6.10.220).

10.11.1.5 Concentrated force distributed longitudinally at center of HSS width and acting parallel to HSS axis

When a concentrated force is distributed longitudinally along the axis of a rectangular HSS and also acts parallel but eccentric to the axis direction of the member, the connection shall be verified as follows:

$$F_{yp} t_p \leq F_u t \quad (6.10.206)$$

10.11.1.6 Concentrated axial force on the end of a rectangular HSS with a cap plate

When a concentrated force acts on the end of a capped HSS and the force is in the direction of the HSS axis, the design strength, ϕR_n and the allowable strength, R_n/Ω , shall be determined for the limit states of wall local yielding (due to tensile or compressive forces) and wall local crippling (due to compressive forces only), with consideration for shear lag, as follows.

If $(5t_p + N) \geq B$, the available strength of HSS is computed by summing the contributions of all four HSS walls.

If $(5t_p + N) < B$, the available strength of the HSS is computed by summing the contributions of the two walls into which the load is distributed.

For the limit state of wall local yielding, for one wall,

$$R_n = F_y t [5t_p + N] \leq B F_y t \quad (6.10.207)$$

$$\phi = 1.00 \text{ (LRFD)} \quad \Omega = 1.50 \text{ (ASD)}$$

For the limit state of wall local crippling, for one wall,

$$R_n = 0.8t^2 \left[1 + \left(\frac{6N}{B} \right) \left(\frac{t}{t_p} \right)^{1.5} \right] \left[\frac{EF_y t_p}{t} \right]^{0.5} \quad (6.10.208)$$

$$\phi = 0.75 \text{ (LRFD)} \quad \Omega = 2.00 \text{ (ASD)}$$

10.11.2 HSS-To-HSS Truss Connections

HSS-to-HSS truss connections are defined as connections that consist of one or more branch members that are directly welded to a continuous chord that passes through the connection and shall be classified as follows:

When the punching load ($P_r \sin \theta$) in a branch member is equilibrated by beam shear in the chord member, the connection shall be classified as a T-connection when the branch is perpendicular to the chord and a Y-connection otherwise.

When the punching load ($P_r \sin \theta$) in a branch member is essentially equilibrated (within 20 percent) by loads in other branch member(s) on the same side of the connection, the connection shall be classified as a K-connection. The relevant gap is between the primary branch members whose loads equilibrate. An N-connection can be considered as a type of K-connection.

When the punching load ($P_r \sin \theta$) is transmitted through the chord member and is equilibrated by branch member(s) on the opposite side, the connection shall be classified as a cross-connection.

When a connection has more than two primary branch members or branch members in more than one plane, the connection shall be classified as a general or multiplanar connection.

When branch members transmit part of their load as K-connections and part of their load as T-, Y-, or cross-connections, the nominal strength shall be determined by interpolation on the proportion of each in total.

For the purposes of this Specification, the centerlines of branch members and chord members shall lie in a common plane. Rectangular HSS connections are further limited to have all members oriented with walls parallel to the plane. For trusses that are made with HSS that are connected by welding branch members to chord members, eccentricities within the limits of applicability are permitted without consideration of the resulting moments for the design of the connection.

10.11.2.1 Notation and Definitions

The notation and their definitions related to this Section are given in Sec 10.1.2.

10.11.2.2 Criteria for round HSS

The interaction of stress due to chord member forces and local branch connection forces shall be incorporated through the chord-stress interaction parameter Q_f .

When the chord is in tension,

$$Q_f = 1$$

When the chord is in compression,

$$Q_f = 1.0 - 0.3U(1 + U) \quad (6.10.209)$$

Where, U is the utilization ratio given by

$$U = \left| \frac{P_r}{(A_g F_c)} + \frac{M_r}{(S F_c)} \right| \quad (6.10.210)$$

And,

P_r = required axial strength in chord, N; for K-connections, P_r is to be determined on the side of the joint that has the lower compression stress (lower U)

M_r = required flexural strength in chord, N-mm.

A_g = chord gross area, mm²

F_c = available stress, MPa.

S = chord elastic section modulus, mm³

For design according to Section 10.2.3.3 (LRFD):

$P_r = P_u$ = required axial strength in chord, using LRFD load combinations, N

$M_r = M_u$ = required flexural strength in chord, using LRFD load combinations, N-mm.

$F_c = F_y$, MPa.

For design according to Section 10.2.3.4 (ASD):

$P_r = P_a$ = required axial strength in chord, using ASD load combinations, N

$M_r = M_a$ = required flexural strength in chord, using ASD load combinations, N-mm.

$f_c = 0.6f_y$, MPa.

10.11.2.2.1 Limits of applicability

The criteria herein are applicable only when the connection configuration is within the following limits of applicability:

- (a) Joint eccentricity: $-0.55D \leq e \leq 0.25D$, where D is the chord diameter and e is positive away from the branches
- (b) Branch angle: $\theta \geq 30^\circ$
- (c) Chord wall slenderness: ratio of diameter to wall thickness less than or equal to 50 for T -, Y - and K -connections; less than or equal to 40 for cross-connections
- (d) Tension branch wall slenderness: ratio of diameter to wall thickness less than or equal to 50
- (e) Compression branch wall slenderness: ratio of diameter to wall thickness $\leq 0.05E/F_y$.
- (f) Width ratio: $0.2 \leq \frac{D_b}{D} \leq 1.0$ in general, and $0.4 \leq \frac{D_b}{D} \leq 1.0$ for gapped K -connections
- (g) If a gap connection: g greater than or equal to the sum of the branch wall thicknesses
- (h) If an overlap connection: $25\% \leq O_v \leq 100\%$, where $O_v = \left(\frac{q}{p}\right) \times 100\%$. P is the projected length of the overlapping branch on the chord; q is the overlap length measured along the connecting face of the chord beneath the two branches. For overlap connections, the larger (or if equal diameter, the thicker) branch is a “thru member” connected directly to the chord.

- (i) Branch thickness ratio for overlap connections: thickness of overlapping branch to be less than or equal to the thickness of the overlapped branch.
- (j) Strength: $F_y \leq 360$ MPa. for chord and branches
- (k) Ductility: $F_y/F_u \leq 0.8$

10.11.2.2.2 Branches with axial loads in T-, Y- and cross-connections

For T- and Y- connections, the design strength of the branch ϕP_n or the allowable strength of the branch, P_n/Ω , shall be the lower value obtained according to the limit states of chord plastification and shear yielding (punching).

For the limit state of chord plastification in T- and Y-connections,

$$P_n \sin \theta = F_y t^2 [3.1 + 15.6\beta^2] \gamma^{0.2} Q_f \quad (6.10.211)$$

$$\phi = 0.90 \text{ (LRFD)} \quad \Omega = 1.67 \text{ (ASD)}$$

For the limit state of shear yielding (punching),

$$P_n = 0.6 F_y t \pi D_b \left[\frac{(1 + \sin \theta)}{2 \sin^2 \theta} \right] \quad (6.10.212)$$

$$\phi = 0.95 \text{ (LRFD)} \quad \Omega = 1.58 \text{ (ASD)}$$

This limit state need not be checked when $\beta > (1 - 1/\gamma)$.

For the limit state of chord plastification in cross-connections,

$$P_n \sin \theta = F_y t^2 \left[\frac{5.7}{(1 - 0.81\beta)} \right] Q_f \quad (6.10.213)$$

$$\phi = 0.90 \text{ (LRFD)} \quad \Omega = 1.67 \text{ (ASD)}$$

10.11.2.2.3 Branches with axial loads in K-connections

For K-connections, the design strength of the branch, ϕP_n and the allowable strength of the branch, P_n/Ω , shall be the lower value obtained according to the limit states of chord plastification for gapped and overlapped connections and shear yielding (punching) for gapped connections only.

For the limit state of chord plastification,

$$\phi = 0.90 \text{ (LRFD)} \quad \Omega = 1.67 \text{ (ASD)}$$

For the compression branch:

$$P_n \sin \theta = F_y t^2 \left[2.0 + \frac{11.33 D_b}{D} \right] Q_g Q_f \quad (6.10.214)$$

Where, D_b refers to the compression branch only, and

$$Q_g = \gamma^{0.2} \left[1 + \frac{0.024 \gamma^{1.2}}{e^{\left(\frac{0.5g}{t} - 1.33\right) + 1}} \right] \quad (6.10.215)$$

In gapped connections, g (measured along the crown of the chord neglecting weld dimensions) is positive. In overlapped connections, g is negative and equals q .

For the tension branch,

$$P_n \sin \theta = (P_n \sin \theta)_{compression \ branch} \quad (6.10.216)$$

For the limit state of shear yielding (punching) in gapped K-connections,

$$P_n = 0.6 F_y t \pi D_b \left[\frac{(1 + \sin \theta)}{2 \sin^2 \theta} \right] \quad (6.10.217)$$

$$\phi = 0.90 \text{ (LRFD)} \quad \Omega = 1.58 \text{ (ASD)}$$

10.11.2.3 Criteria for rectangular HSS

The interaction of stress due to chord member forces and local branch connection forces shall be incorporated through the chord-stress interaction parameter Q_f .

When the chord is in tension,

$$Q_f = 1$$

When the chord is in compression in T -, Y -, and cross-connections,

$$Q_f = 1.3 - 0.4U/\beta \leq 1 \quad (6.10.218)$$

When the chord is in compression in gapped K -connections,

$$Q_f = 1.3 - 0.4U/\beta_{eff} \leq 1 \quad (6.10.219)$$

Where, U is the utilization ratio given by

$$U = \left| \frac{P_r}{(A_g F_c)} + \frac{M_r}{(S F_c)} \right| \quad (6.10.220)$$

And,

P_r = required axial strength in chord, N. For gapped K-connections, P_r is to be determined on the side of the joint that has the higher compression stress (higher U).

M_r = required flexural strength in chord, N-mm.

A_g = chord gross area, mm²

F_c = available stress, MPa.

S = chord elastic section modulus, mm³

For design according to Section 10.2.3.3 (LRFD):

$P_r = P_u$ = required axial strength in chord, using *LRFD load combinations*, N

$M_r = M_u$ = required flexural strength in chord, using LRFD load combinations, N-mm.

$F_c = F_u$, MPa.

For design according to Section 10.2.3.4 (ASD):

$P_r = P_a$ = required axial strength in chord, using *ASD load combinations*, N.

$M_r = M_a$ = required flexural strength in chord, using ASD load combinations, N-mm.

$F_c = 0.6F_y$, MPa.

10.11.2.3.1 Limits of applicability

The criteria herein are applicable only when the connection configuration is within the following limits:

- (a) Joint eccentricity: $-0.55H \leq e \leq 0.25H$, where H is the chord depth and e is positive away from the branches
- (b) Branch angle: $\theta \geq 30^\circ$

- (c) Chord wall slenderness: ratio of overall wall width to thickness less than or equal to 35 for gapped K-connections and T-, Y- and cross-connections; less than or equal to 30 for overlapped K-connections
- (d) Tension branch wall slenderness: ratio of overall wall width to thickness less than or equal to 35
- (e) Compression branch wall slenderness: ratio of overall wall width to thickness less than or equal to $1.25(E/F_{yb})^{0.5}$ and also less than 35 for gapped K-connections and T-, Y- and cross-connections; less than or equal to $1.1(E/F_{yb})^{0.5}$ for overlapped K-connections
- (f) Width ratio: ratio of overall wall width of branch to overall wall width of chord greater than or equal to 0.25 for T-, Y-, cross- and overlapped K-connections; greater than or equal to 0.35 for gapped K-connections
- (g) Aspect ratio: $0.5 \leq \text{ratio of depth to width} \leq 2.0$
- (h) Overlap: $25\% \leq O_v \leq 100\%$, where $O_v = \left(\frac{q}{p}\right) \times 100\%$. p is the projected length of the overlapping branch on the chord; q is the overlap length measured along the connecting face of the chord beneath the two branches. For overlap connections, the larger (or if equal width, the thicker) branch is a “thru member” connected directly to the chord
- (i) Branch width ratio for overlap connections: ratio of overall wall width of overlapping branch to overall wall width of overlapped branch greater than or equal to 0.75
- (j) Branch thickness ratio for overlap connections: thickness of overlapping branch to be less than or equal to the thickness of the overlapped branch
- (k) Strength: $F_y \leq 360$ MPa. for chord and branches
- (l) Ductility: $F_y/F_u \leq 0.8$
- (m) Other limits apply for specific criteria

10.11.2.3.2 Branches with axial loads in T-,Y- and cross-connections

For T-, Y- and cross-connections, the design strength of the branch, ϕP_n or the allowable strength of the branch, P_n/Ω , shall be the lowest value obtained according to the limit states of chord wall plastification, shear yielding (punching), sidewall strength and local yielding due to uneven load distribution. In addition to the limits of applicability in Section 10.11.2.3a, β shall not be less than 0.25.

For the limit state of chord wall plastification,

$$P_n \sin \theta = F_y t^2 \left[\frac{2\eta}{(1-\beta)} + \frac{4}{(1-\beta)^{0.5}} \right] Q_f \quad (6.10.221)$$

$$\phi = 1.00 \text{ (LRFD)} \quad \Omega = 1.50 \text{ (ASD)}$$

This limit state need not be checked when $\beta > 0.85$.

For the limit state of shear yielding (punching),

$$P_n \sin \theta = 0.6 F_y t B [2\eta + 2\beta_{eop}] \quad (6.10.222)$$

$$\phi = 0.95 \text{ (LRFD)} \quad \Omega = 1.58 \text{ (ASD)}$$

In Eq. 6.10.222, the effective outside punching parameter $\beta_{eop} = 5\beta/\gamma$ shall not exceed β .

This limit state need not be checked when $\beta > (1 - 1/\gamma)$, nor when $\beta < 0.85$ and $B/t \geq 10$.

For the limit state of sidewall strength, the available strength for branches in tension shall be taken as the available strength for sidewall local yielding. For the limit state of sidewall strength, the available strength for branches in compression shall be taken as the lower of the strengths for sidewall local yielding and sidewall local crippling. For cross-connections with a branch angle less than 90° , an additional check for chord sidewall shear failure must be made in accordance with Section 10.7.5.

This limit state need not be checked unless the chord member and branch member have same width ($\beta = 1.0$)

For the limit state of local yielding,

$$P_n \sin \theta = 2F_y t [5k + N] \quad (6.10.223)$$

$$\phi = 1.00 \text{ (LRFD)} \quad \Omega = 1.50 \text{ (ASD)}$$

Where,

k = outside corner radius of the HSS, which is permitted to be taken as $1.5t$ if unknown, mm.

N = bearing length of the load, parallel to the axis of the HSS main member, $H_b/\sin \theta$, mm.

For the limit state of sidewall local crippling, in T- and Y-connections,

$$P_n \sin \theta = 1.6t^2 \left[1 + \frac{3N}{(H-3t)} \right] (EF_y)^{0.5} Q_f \quad (6.10.224)$$

$$\phi = 0.75 \text{ (LRFD)} \quad \Omega = 2.00 \text{ (ASD)}$$

For the limit state of sidewall local crippling in cross-connections,

$$P_n \sin \theta = \left[\frac{48t^3}{(H-3t)} \right] (EF_y)^{0.5} Q_f \quad (6.10.225)$$

$$\phi = 0.90 \text{ (LRFD)} \quad \Omega = 1.67 \text{ (ASD)}$$

For the limit state of local yielding due to uneven load distribution,

$$P_n = F_{yb} t_b [2H_b + 2b_{eoi} - 4t_b] \quad (6.10.226)$$

$$\phi = 0.95 \text{ (LRFD)} \quad \Omega = 1.58 \text{ (ASD)}$$

Where,

$$b_{eoi} = \left[\frac{10}{\left(\frac{B}{t}\right)} \right] [F_y t / (F_{yb} t_b)] B_b \leq B_b \quad (6.10.227)$$

This limit state need not be checked when $\beta < 0.85$.

10.11.2.3.3 Branches with axial loads in gapped K-connections

For gapped K-connections, the design strength of the branch, ϕP_n or the allowable strength of the branch, P_n/Ω , shall be the lowest value obtained according to the limit states of chord wall plastification, shear yielding (punching), shear yielding and local yielding due to uneven load distribution. In addition to the limits of applicability in Sec 10.11.2.3.1, the following limits shall apply:

- (a) $B_b/B \geq 0.1 + \gamma/50$
- (b) $\beta_{eff} \geq 0.35$
- (c) $\zeta \leq 0.5(1 - \beta_{eff})$
- (d) Gap: g greater than or equal to the sum of the branch wall thicknesses
- (e) The smaller $B_b > 0.63$ times the larger B_b

For the limit state of chord wall plastification,

$$P_n \sin \theta = F_y t^2 [9.8 \beta_{eff} \gamma^{0.5}] Q_f \quad (6.10.228)$$

$$\phi = 0.90 \text{ (LRFD)} \quad \Omega = 1.67 \text{ (ASD)}$$

For the limit state of shear yielding (punching),

$$P_n \sin \theta = 0.6 F_y t B [2\eta + \beta + \beta_{eop}] \quad (6.10.229)$$

$$\phi = 0.95 \text{ (LRFD)} \quad \Omega = 1.58 \text{ (ASD)}$$

In the above equation, the effective outside punching parameter $\beta_{eop} = 5\beta/\gamma$ shall not exceed β .

This limit state need only be checked if $B_b < (B - 2t)$ or the branch is not square.

For the limit state of shear yielding of the chord in the gap, available strength shall be checked in accordance with Sec 10.7. This limit state need only be checked if the chord is not square.

For the limit state of local yielding due to uneven load distribution,

$$P_n = F_{yb} t_b [2H_b + B_b + b_{eoi} - 4t_b] \quad (6.10.230)$$

$$\phi = 0.95 \text{ (LRFD)} \quad \Omega = 1.58 \text{ (ASD)}$$

Where,

$$b_{eoi} = \left[\frac{10}{\left(\frac{B}{t}\right)} \right] [F_y t / (F_{yb} t_b)] B_b \leq B_b \quad (6.10.231)$$

This limit state need only be checked if the branch is not square or $B/t < 15$.

10.11.2.3.4 Branches with axial loads in overlapped K-connections

For overlapped K-connections, the design strength of the branch, ϕP_n or the allowable strength of the branch, P_n/Ω shall be determined from the limit state of local yielding due to uneven load distribution,

$$\phi = 0.95 \text{ (LRFD)} \quad \Omega = 1.58 \text{ (ASD)}$$

For the overlapping branch and for overlap $25\% \leq O_v \leq 50\%$, measured with respect to overlapping branch,

$$P_n = F_{ybi} t_{bi} \left[\left(\frac{O_v}{50} \right) (2H_{bi} - 4t_{bi}) + b_{eoi} + b_{eov} \right] \quad (6.10.232)$$

For the overlapping branch, and for overlap $50\% \leq O_v < 80\%$ measured with respect to overlapping branch,

$$P_n = F_{ybi} t_{bi} [2H_{bi} - 4t_{bi} + b_{eoi} + b_{eov}] \quad (6.10.233)$$

For the overlapping branch and for overlap $80\% \leq O_v \leq 100\%$ measured with respect to overlapping branch,

$$P_n = F_{ybi} t_{bi} [2H_{bi} - 4t_{bi} + B_{bi} + b_{eov}] \quad (6.10.234)$$

Where, b_{eoi} is the effective width of the branch face welded to the chord,

$$b_{eoi} = \left[\frac{10}{\left(\frac{B}{t} \right)} \right] [(F_y t) / (F_{ybi} t_{bi})] B_{bi} \leq B_{bi} \quad (6.10.235)$$

b_{eov} is the effective width of the branch face welded to the overlapped brace,

$$b_{eov} = \left[\frac{10}{\left(\frac{B_{bj}}{t_{bj}} \right)} \right] [(F_{ybj} t_{bj}) / (F_{ybi} t_{bi})] B_{bi} \leq B_{bi} \quad (6.10.236)$$

B_{bi} = overall branch width of the overlapping branch, mm.

B_{bj} = overall branch width of the overlapped branch, mm.

F_{ybi} = specified minimum yield stress of the overlapping branch material, MPa.

F_{ybj} = specified minimum yield stress of the overlapped branch material, MPa.

H_{bi} = overall depth of the overlapping branch, mm.

T_{bi} = thickness of the overlapping branch, mm.

t_{bj} = thickness of the overlapped branch, mm.

For the overlapped branch, P_n shall not exceed P_n of the overlapping branch, calculated using Eq. 6.10.232, Eq. 6.10.233 or Eq. 6.10.234, as applicable, multiplied by the factor $(A_{bj}F_{ybj}/A_{bi}F_{ybi})$.

Where,

A_{bi} = cross-sectional area of the overlapping branch

A_{bj} = cross-sectional area of the overlapped branch

10.11.2.3.5 Welds to branches

The nonuniformity of load transfer along the line of weld, due to differences in relative flexibility of HSS walls in HSS-to-HSS connections, shall be considered in proportioning such welds. This can be considered by limiting the total effective weld length, L_e , of groove and fillet welds to rectangular HSS as follows:

In T-, Y- and cross-connections,

For $\theta \geq 50^\circ$

$$L_e = \frac{2(H_b - 1.2t_b)}{\sin \theta} + (B_b - 1.2t_b) \quad (6.10.237)$$

For $\theta \geq 60^\circ$

$$L_e = \frac{2(H_b - 1.2t_b)}{\sin \theta} \quad (6.10.238)$$

Linear interpolation shall be used to determine L_e for values of θ between 50° and 60° .

In gapped K-connections, around each branch,

For $\theta \geq 50^\circ$

$$L_e = \frac{2(H_b - 1.2t_b)}{\sin \theta} + 2(B_b - 1.2t_b) \quad (6.10.239)$$

For $\theta \geq 60^\circ$

$$L_e = \frac{2(H_b - 1.2t_b)}{\sin \theta} + (B_b - 1.2t_b) \quad (6.10.240)$$

Linear interpolation shall be used to determine L_e for values of θ between 50° and 60° .

In lieu of the above criteria in Equations 6.10.237 to 6.10.240, other rational criteria are permitted.

10.11.3 HSS-To-HSS Moment Connections

HSS-to-HSS moment connections are defined as connections that consist of one or two branch members that are directly welded to a continuous chord that passes through the connection, with the branch or branches loaded by bending moments. A connection shall be classified

As a T-connection when there is one branch and it is perpendicular to the chord and as a Y-connection when there is one branch but not perpendicular to the chord.

As a cross-connection when there is a branch on each (opposite) side of the chord.

For the purposes of this Specification, the centerlines of the branch member(s) and the chord member shall lie in a common plane.

10.11.3.1 Notation and definitions

The notation and their definitions related to this Section are given in Sec 10.1.2.

10.11.3.2 Criteria for round HSS

The interaction of stress due to chord member forces and local branch connection forces shall be incorporated through the chord-stress interaction parameter Q_f .

When the chord is in tension,

$$Q_f = 1$$

When the chord is in compression,

$$Q_f = 1.0 - 0.3U(1 + U) \quad (6.10.241)$$

Where, U is the utilization ratio given by

$$U = \left| \frac{P_r}{A_g F_c} + \frac{M_r}{S F_c} \right| \quad (6.10.242)$$

And,

P_r = required axial strength in chord, N.

M_r = required flexural strength in chord, N-mm.

A_g = chord gross area, mm²

F_c = available stress, MPa.

S = chord elastic section modulus, mm³

For design according to Section 10.2.3.3 (LRFD):

$P_r = P_u$ = required axial strength in chord, using LRFD load combinations, N

$M_r = M_u$ = required flexural strength in chord, using LRFD load combinations, N-mm.

$F_c = F_y$, MPa.

For design according to Section 10.2.3.4 (ASD):

$P_r = P_a$ = required axial strength in chord, using *ASD load combinations*, N

$M_r = M_a$ = required flexural strength in chord, using ASD load combinations, N-mm.

$F_c = 0.6F_y$, MPa.

10.11.3.2.1 Limits of applicability

The criteria herein are applicable only when the connection configuration is within the following limits of applicability:

- (a) Branch angle: $\theta \geq 30^\circ$
- (b) Chord wall slenderness: ratio of diameter to wall thickness less than or equal to 50 for T - and Y-connections; less than or equal to 40 for cross-connections
- (c) Tension branch wall slenderness: ratio of diameter to wall thickness less than or equal to 50
- (d) Compression branch wall slenderness: ratio of diameter to wall thickness less than or equal to $0.05 E/F_y$
- (e) Width ratio: $0.2 < D_b/D \leq 1.0$
- (f) Strength: $F_y \leq 360$ MPa. for chord and branches
- (g) Ductility: $F_y/F_u \leq 0.8$

10.11.3.2.2 Branches with In-plane bending moments in T-, Y- and cross-connections

The design strength, ϕM_n and the allowable strength, M_n/Ω , shall be the lowest value obtained according to the limit states of chord plastification and shear yielding (punching).

For the limit state of chord plastification,

$$M_n \sin \theta = 5.39 F_y t^2 \gamma^{0.5} \beta D_b Q_f \quad (6.10.243)$$

$$\phi = 0.90 \text{ (LRFD)} \quad \Omega = 1.67 \text{ (ASD)}$$

For the limit state of shear yielding (punching),

$$M_n = 0.6 F_y t D_b^2 [(1 + 3 \sin \theta)/4 \sin^2 \theta] \quad (6.10.244)$$

$$\phi = 0.95 \text{ (LRFD)} \quad \Omega = 1.58 \text{ (ASD)}$$

This limit state need not be checked when $\beta > (1 - 1/\gamma)$.

10.11.3.2.3 Branches with out-of-plane bending moments in T-, Y- and cross-connections

The design strength, ϕM_n and the allowable strength, M_n/Ω , shall be the lowest value obtained according to the limit states of chord plastification and shear yielding (punching).

For the limit state of chord plastification,

$$M_n \sin \theta = F_y t^2 D_b \left[\frac{3.0}{1 - 0.81\beta} \right] Q_f \quad (6.10.245)$$

$$\phi = 0.90 \text{ (LRFD)} \quad \Omega = 1.67 \text{ (ASD)}$$

For the limit state of shear yielding (punching),

$$M_n = 0.6 F_y t D_b^2 [(3 + \sin \theta)/4 \sin^2 \theta] Q_f \quad (6.10.246)$$

$$\phi = 0.95 \text{ (LRFD)} \quad \Omega = 1.58 \text{ (ASD)}$$

This limit state need not be checked when $\beta > (1 - 1/\gamma)$.

10.11.3.2.4 Branches with combined bending moment and axial force in T-, Y- and cross-connections

Connections subject to branch axial load, branch in-plane bending moment, and branch out-of-plane bending moment, or any combination of these load effects, should satisfy the following.

For design according to Section 10.2.3.3 (LRFD):

$$\left(\frac{P_r}{\phi P_n}\right) + \left(\frac{M_{r-ip}}{\phi M_{n-ip}}\right)^2 + (M_{r-op}/\phi M_{n-op}) \leq 1.0 \quad (6.10.247)$$

Where,

$P_r = P_u$ = required axial strength in branch, using LRFD load combinations, N

ϕP_n = design strength obtained from Sec 10.11.2.2.2

M_{r-ip} = required in-plane flexural strength in branch, using LRFD load combinations, N-mm.

ϕM_{n-ip} = design strength obtained from Sec 10.11.3.2.2

M_{r-op} = required out-of-plane flexural strength in branch, using LRFD load combinations, N-mm.

ϕM_{n-op} = design strength obtained from Sec 10.11.3.2.3

For design according to Section 10.2.3.4 (ASD):

$$\left(P_r/\left(\frac{P_n}{\Omega}\right)\right) + \left(\frac{M_{r-ip}}{\frac{M_{n-ip}}{\Omega}}\right)^2 + (M_{r-op}/(M_{n-op}/\Omega)) \leq 1.0 \quad (6.10.248)$$

Where,

$P_r = P_a$ = required axial strength in branch, using ASD load combinations, N

P_n/Ω = allowable strength obtained from Sec 10.11.2.2.2

M_{r-ip} = required in-plane flexural strength in branch, using ASD load combinations, N-mm.

M_{n-ip}/Ω = allowable strength obtained from Sec 10.11.3.2.2

M_{r-op} = required out-of-plane flexural strength in branch, using ASD load combinations, N-mm.

M_{n-op}/Ω = allowable strength obtained from Sec 10.11.3.2.3

10.11.3.3 Criteria for rectangular HSS

The interaction of stress due to chord member forces and local branch connection forces shall be incorporated through the chord-stress interaction parameter Q_f .

When the chord is in tension,

$$Q_f = 1$$

When the chord is in compression,

$$Q_f = \left(1.3 - \frac{0.4U}{\beta}\right) \leq 1 \quad (6.10.249)$$

Where, U is the utilization ratio given by

$$U = \left| \frac{P_r}{A_g F_c} + \frac{M_r}{S F_c} \right| \quad (6.10.250)$$

And,

P_r = required axial strength in chord, N.

M_r = required flexural strength in chord, N-mm.

A_g = chord gross area, mm²

F_c = available stress, MPa.

S = chord elastic section modulus, mm³.

For design according to Section 10.2.3.3 (LRFD):

$P_r = P_u$ = required axial strength in chord, using LRFD load combinations, N

$M_r = M_u$ = required flexural strength in chord, using LRFD load combinations, N-mm.

$F_c = F_y$, MPa.

For design according to Section 10.2.3.4 (ASD):

$P_r = P_a$ = required axial strength in chord, using ASD load combinations, N

$M_r = M_a$ = required flexural strength in chord, using ASD load combinations, N-mm.

$F_c = 0.6F_y$, MPa.

10.11.3.3.1 Limits of applicability

The criteria herein are applicable only when the connection configuration is within the following limits:

- (a) Branch angle is approximately 90°
- (b) Chord wall slenderness: ratio of overall wall width to thickness less than or equal to 35
- (c) Tension branch wall slenderness: ratio of overall wall width to thickness less than or equal to 35
- (d) Compression branch wall slenderness: ratio of overall wall width to thickness less than or equal to $1.25(E/F_{yb})^{0.5}$ and also less than 35
- (e) Width ratio: ratio of overall wall width of branch to overall wall width of chord greater than or equal to 0.25
- (f) Aspect ratio: $0.5 \leq \text{ratio of depth to width} \leq 2.0$
- (g) Strength: $F_y \leq 360$ MPa. for chord and branches
- (h) Ductility: $F_y/F_u \leq 0.8$
- (i) Other limits apply for specific criteria

10.11.3.3.2 Branches with In-plane bending moments in T- and cross-connections

The design strength ϕM_n and the allowable strength, M_n/Ω , shall be the lowest value obtained according to the limit states of chord wall plastification, sidewall local yielding and local yielding due to uneven load distribution.

For the limit state of chord wall plastification,

$$M_n = F_y t^2 H_b \left[\left(\frac{1}{2\eta} \right) + \frac{2}{(1-\beta)^{0.5}} + \frac{\eta}{1-\beta} \right] Q_f \quad (6.10.251)$$

$$\phi = 1.00 \text{ (LRFD)} \quad \Omega = 1.50 \text{ (ASD)}$$

This limit state need not be checked when $\beta > 0.85$.

For the limit state of sidewall local yielding,

$$M_n = 0.5F_y^*t(H_b + 5t)^2 \quad (6.10.252)$$

$$\phi = 1.00(\text{LRFD}) \quad \Omega = 1.50 (\text{ASD})$$

Where,

$$F_y^* = F_y \text{ for T-connections}$$

$$F_y^* = 0.8 F_y \text{ for cross-connections}$$

This limit state need not be checked when $\beta < 0.85$.

For the limit state of local yielding due to uneven load distribution,

$$M_n = F_{yb} \left[Z_b - \left(1 - \frac{b_{eoi}}{B_b} \right) B_b H_b t_b \right] \quad (6.10.253)$$

$$\phi = 0.95 (\text{LRFD}) \quad \Omega = 1.58 (\text{ASD})$$

Where,

$$b_{eoi} = \left[\frac{10}{\left(\frac{B}{t}\right)} \right] [F_y t / (F_{yb} t_b)] B_b \leq B_b \quad (6.10.254)$$

Z_b = branch plastic section modulus about the axis of bending, mm^3 .

This limit state need not be checked when $\beta < 0.85$.

10.11.3.3.3 Branches with out-of-plane bending moments in T- and cross-connections

The design strength, ϕM_n and the allowable strength, M_n/Ω , shall be the lowest value obtained according to the limit states of chord wall plastification, sidewall local yielding, local yielding due to uneven load distribution and chord distortional failure.

For the limit state of chord wall plastification,

$$M_n = F_y t^2 \left[\frac{0.5H_b(1+\beta)}{(1-\beta)} + \left[\frac{2BB_b(1+\beta)}{1-\beta} \right]^{0.5} \right] Q_f \quad (6.10.255)$$

$$\phi = 1.00 (\text{LRFD}) \quad \Omega = 1.50 (\text{ASD})$$

This limit state need not be checked when $\beta > 0.85$.

For the limit state of sidewall local yielding,

$$M_n = F_y^* t (B - t) (H_b + 5t) \quad (6.10.256)$$

$$\phi = 1.00 \text{ (LRFD)} \quad \Omega = 1.50 \text{ (ASD)}$$

Where,

$$F_y^* = F_y \text{ for T-connections}$$

$$F_y^* = 0.8 F_y \text{ for cross-connections}$$

This limit state need not be checked when $\beta < 0.85$.

For the limit state of local yielding due to uneven load distribution,

$$M_n = F_{yb} \left[Z_b - 0.5 \left(1 - \frac{b_{eoi}}{B_b} \right)^2 B_b^2 t_b \right] \quad (6.10.257)$$

$$\phi = 0.95 \text{ (LRFD)} \quad \Omega = 1.58 \text{ (ASD)}$$

Where,

$$b_{eoi} = \left[\frac{10}{\left(\frac{B}{t}\right)} \right] [F_y t / (F_{yb} t_b)] B_b \leq B_b \quad (6.10.258)$$

Z_b = branch plastic section modulus about the axis of bending, mm³.

This limit state need not be checked when $\beta < 0.85$.

For the limit state of chord distortional failure,

$$M_n = 2F_y t [H_b t + [BHt(B + H)]^{0.5}] \quad (6.10.259)$$

$$\phi = 1.00 \text{ (LRFD)} \quad \Omega = 1.50 \text{ (ASD)}$$

This limit state need not be checked for cross-connections or for T-connections if chord distortional failure is prevented by other means.

10.11.3.3.4 Branches with combined bending moment and axial force in T- and cross-connections

Connections subject to branch axial load, branch in-plane bending moment and branch out-of-plane bending moment, or any combination of these load effects, should satisfy,

For design according to Section 10.2.3.3 (LRFD):

$$\left(\frac{P_r}{\phi P_n}\right) + \left(\frac{M_{r-ip}}{\phi M_{n-ip}}\right) + \left(\frac{M_{r-op}}{\phi M_{n-op}}\right) \leq 1.0 \quad (6.10.260)$$

Where,

$P_r = P_u$ = required axial strength in branch, using LRFD load combinations, N

ϕP_n = design strength obtained from Sec 10.11.2.3.2

M_{r-ip} = required in-plane flexural strength in branch, using LRFD load combinations, N-mm.

ϕM_{n-ip} = design strength obtained from Sec 10.11.3.3.2

M_{r-op} = required out-of-plane flexural strength in branch, using LRFD load combinations, N-mm.

ϕM_{n-op} = design strength obtained from Sec 10.11.3.3.3

For design according to Section 10.2.3.4 (ASD):

$$\left(\frac{P_r}{\frac{P_n}{\Omega}}\right) + \left(\frac{M_{r-ip}}{\frac{M_{n-ip}}{\Omega}}\right) + \left(\frac{M_{r-op}}{\frac{M_{n-op}}{\Omega}}\right) \leq 1.0 \quad (6.10.261)$$

Where,

$P_r = P_a$ = required axial strength in branch, using ASD load combinations, N

P_n/Ω = allowable strength obtained from Sec 10.11.2.3.2

M_{r-ip} = required in-plane flexural strength in branch, using ASD load combinations, N-mm.

M_{n-ip}/Ω = allowable strength obtained from Sec 10.11.3.3.2

M_{r-op} = required out-of-plane flexural strength in branch, using ASD load combinations, N-mm.

M_{n-op}/Ω = allowable strength obtained from Sec 10.11.3.3.3

10.12 Design for Serviceability

This Chapter addresses serviceability performance design requirements.

10.12.1 General Provisions

Serviceability is a state in which the function of a building, its appearance, maintainability, durability, and comfort of its occupants are preserved under normal usage. Limiting values of structural behavior for serviceability (for example, maximum deflections, accelerations) shall be chosen with due regard to the intended function of the structure. Serviceability shall be evaluated using appropriate load combinations for the serviceability limit states identified.

10.12.2 Camber

Where camber is used to achieve proper position and location of the structure, the magnitude, direction and location of camber shall be specified in the structural drawings in accordance with the provisions of Chapter 1.

10.12.3 Deflections

Deflections in structural members and structural systems under appropriate service load combinations shall not impair the serviceability of the structure. Limiting values of deflections of various structural members shall be in accordance with those specified in Sec 1.4 Chapter 1.

10.12.4 Drift

Drift of a structure shall be evaluated under service loads to provide for serviceability of the structure, including the integrity of interior partitions and exterior cladding. Drift under strength load combinations shall not cause collision with adjacent structures or exceed the limiting values specified in Sec 1.5.6 Chapter 1.

10.12.5 Vibration

The effect of vibration on the comfort of the occupants and the function of the structure shall be considered. Sources of vibration to be considered include pedestrian loading, vibrating machinery and others identified for the structure. It must be shown by any rational method of analysis that the vibrations induced by any source including the above mentioned ones is within tolerable limit and shall not cause any adverse effect on the safety, stability and durability of the structure.

10.12.6 Wind-Induced Motion

The effect of wind-induced motion of buildings on the comfort of occupants shall be considered. For flexible building and structures as defined in Sec. 2.4.2 Chapter 2, it must be shown by a rational dynamic analysis that wind induced vibration does not cause any discomfort to occupants as well as the wind induced dynamic effect does not cause any adverse effect on the safety, stability and durability of the structure.

10.12.7 Expansion and Contraction

The effects of thermal expansion and contraction of a building shall be considered. Damage to building *cladding* can cause water penetration and may lead to corrosion.

10.12.8 Connection Slip

The effects of connection slip shall be included in the design where slip at bolted connections may cause deformations that impair the serviceability of the structure. Where appropriate, the connection shall be designed to preclude slip. For the design of slip-critical connections see Sections 10.10.3.8 and 10.10.3.9.

10.13 Fabrication, Erection and Quality Control

This Chapter addresses requirements for design and shop drawings, fabrication, shop painting, erection and quality control.

10.13.1 Design Drawings and Specifications

Structural Design Drawings and Specifications

Unless otherwise indicated in the contract documents, the structural design drawings shall be based upon consideration of the design loads and forces to be resisted by structural steel frame in the completed project.

The structural design drawings shall clearly show the work that is to be performed and shall give the following information with sufficient dimensions to accurately convey the quantity and nature of the structural steel to be fabricated:

- (a) The size, section, material grade and location of all members;
- (b) All geometry and working points necessary for layout;
- (c) Floor elevations;
- (d) Column centers and offsets;

- (e) The camber requirements for members;
- (f) Joining requirements between elements of built-up members; and,
- (g) The information that is required in Sections 10.13.1.1.1 to 10.13.1.1.6.

The structural steel specifications shall include any special requirements for the fabrication and erection of the structural steel.

The structural design drawings, specifications and addenda shall be numbered and dated for the purposes of identification.

10.13.1.1 Detailing of components

Permanent bracing, column stiffeners, column web doubler plates, bearing stiffeners in beams and girders, web reinforcement, openings for other trades and other special details, where required, shall be shown in sufficient detail in the structural design drawings so that the quantity, detailing and fabrication requirements for these items can be readily understood.

10.13.1.2 Designer's responsibility

The owner's designated representative for design shall indicate one of the following options for each connection:

- (1) The complete connection design shall be shown in the structural design drawings;
- (2) In the structural design drawings or specifications, the connection shall be designated to be selected or completed by an experienced steel detailer; or,
- (3) In the structural design drawings or specifications, the connection shall be designated to be designed by a licensed professional engineer working for the fabricator.

In all of the above options,

- (a) The requirements of Sec 10.13.1.1 shall apply; and,
- (b) The approvals process in Sec 10.13.2.4 shall be followed.

When option (2) above is specified:

The experienced steel detailer shall utilize tables or schematic information provided in the structural design drawings in the selection or completion of the connections. When such information is not provided, standard reference information as approved by the owner's designated representative for design, shall be used.

When option (2) or (3) above is specified:

The owner's designated representative for design shall provide the following information in the structural design drawings and specifications:

- (a) Any restrictions on the types of connections that are permitted;
- (b) Data concerning the loads, including shears, moments, axial forces and transfer forces, that are to be resisted by the individual members and their connections, sufficient to allow the selection, completion, or design of the connection details while preparing the shop and erection drawings;
- (c) Whether the data required in (b) is given at the service-load level or the factored-load level;
- (d) Whether LRFD or ASD is to be used in the selection, completion, or design of connection details; and,
- (e) What substantiating connection information, if any, is to be provided with the shop and erection drawings to the owner's designated representative for design.

When option (3) above is specified:

- (a) The fabricator shall submit in a timely manner representative samples of the required substantiating connection information to the owner's designated representatives for design and construction. The owner's designated representative for design shall confirm in writing in a timely manner that these representative samples are consistent with the requirements in the contract documents, or shall advise what modifications are required to bring the representative samples into compliance with the requirements in the contract documents. This initial submittal and review is in addition to the requirements in Sec 10.13.2.4.
- (b) The Engineer in responsible charge of the connection design shall review and confirm in writing as part of the substantiating connection information, that the shop and erection drawings properly incorporate the connection designs. However, this review by the Engineer in responsible charge of the connection design does not replace the approval process of the shop and erection drawings by the owner's designated representative for design in Sec 10.13.2.4.
- (c) The fabricator shall provide a means by which the substantiating connection information is referenced to the related connections on the shop and erection drawings for the purpose of review.

10.13.1.2.1 Levelling plates

When leveling plates are to be furnished as part of the contract requirements, their locations and required thickness and sizes shall be specified in the contract documents.

10.13.1.2.2 Non-structural elements

When the structural steel frame, in the completely erected and fully connected state, requires interaction with non-structural steel elements for strength and/or stability, those non-structural steel elements shall be identified in the contract documents as required in Sec 10.13.5.10.

10.13.1.2.3 Camber

When camber is required, the magnitude, direction and location of camber shall be specified in the structural design drawings.

10.13.1.2.4 Painting information

Specific members or portions thereof that are to be left unpainted shall be identified in the contract documents. When shop painting is required, the painting requirements shall be specified in the contract documents, including the following information:

- (a) The identification of specific members or portions thereof to be painted;
- (b) The surface preparation that is required for these members;
- (c) The paint specifications and manufacturer's product identification that are required for these members; and,
- (d) The minimum dry-film shop-coat thickness that is required for these members.

10.13.1.3 Architectural, electrical and mechanical design drawings and specifications

All requirements for the quantities, sizes and locations of structural steel shall be shown or noted in the structural design drawings. The use of architectural, electrical and/or mechanical design drawings as a supplement to the structural design drawings is permitted for the purposes of defining detail configurations and construction information.

10.13.1.4 Discrepancies

When discrepancies exist between the design drawings and specifications, the design drawings shall govern. When discrepancies exist between scale dimensions in the design drawings and the figures written in them, the figures shall govern. When discrepancies exist between the structural design drawings and the architectural, electrical or mechanical design drawings or design drawings for other trades, the structural design drawings shall govern.

When a discrepancy is discovered in the contract documents in the course of the fabricator's work, the fabricator shall promptly notify the owner's designated representative for construction so that the discrepancy can be resolved by the owner's designated representative for design. Such resolution shall be timely so as not to delay the fabricator's work. See Sections 10.13.1.5 and 10.13.7.3.

10.13.1.5 Legibility of design drawings

Design drawings shall be clearly legible and drawn to an identified scale that is appropriate to clearly convey the information.

10.13.1.6 Revisions to the design drawings and specifications

Revisions to the design drawings and specifications shall be made either by issuing new design drawings and specifications or by reissuing the existing design drawings and specifications. In either case, all revisions, including revisions that are communicated through responses to RFIs or the annotation of shop and/or erection drawings (see Sec 10.13.2.4.2), shall be clearly and individually indicated in the contract documents. The contract documents shall be dated and identified by revision number. Each design drawings shall be identified by the same drawing number throughout the duration of the project, regardless of the revision. See also Sec 10.13.7.3.

10.13.2 Shop and Erection Drawings

Shop drawings shall be prepared in advance of fabrication and give complete information necessary for the fabrication of the component parts of the structure, including the location, type and size of welds and bolts. Erection drawings shall be prepared in advance of erection and give information necessary for erection of the structure. Shop and erection drawings shall clearly distinguish between shop and field welds and bolts and shall clearly identify pretensioned and slip-critical high-strength bolted connections. Shop and erection drawings shall be made with due regard to speed and economy in fabrication and erection.

10.13.2.1 Owner responsibility

The owner shall furnish, in a timely manner and in accordance with the contract documents, complete structural design drawings and specifications that have been released for construction. Unless otherwise noted, design drawings that are provided as part of a contract bid package shall constitute authorization by the owner that the design drawings are released for construction.

Records of the meetings should be written and distributed to all parties. Subsequent meetings to discuss progress and issues that arise during construction also can be helpful, particularly when they are held on a regular schedule.

10.13.2.2 Fabricator responsibility

Except as provided in Sec 10.13.2.5, the fabricator shall produce shop and erection drawings for the fabrication and erection of the structural steel and is responsible for the following :

- (a) The transfer of information from the contract documents into accurate and complete shop and erection drawings; and,
- (b) The development of accurate, detailed dimensional information to provide for the fit-up of parts in the field.

Each shop and erection drawing shall be identified by the same drawing number throughout the duration of the project and shall be identified by revision number and date, with each specific revision clearly identified.

When the fabricator submits a request to change connection details that are described in the contract documents, the fabricator shall notify the owner's designated representatives for design and construction in writing in advance of the submission of the shop and erection drawings. The owner's designated representative for design shall review and approve or reject the request in a timely manner.

When requested to do so by the owner's designated representative for design, the fabricator shall provide to the owner's designated representatives for design and construction its schedule for the submittal of shop and erection drawings so as to facilitate the timely flow of information between all parties.

10.13.2.3 Use of CAD files and/or copies of design drawings

The fabricator shall neither use nor reproduce any part of the design drawings as part of the shop or erection drawings without the written permission of the owner's designated representative for design. When CAD files or copies of the design drawings are made available for the fabricator's use, the fabricator shall accept this information under the following conditions:

- (a) All information contained in the CAD files or copies of the design drawings shall be considered instruments of service of the owner's designated representative for design and shall not be used for other projects, additions to the project or the completion of the project by others. CAD files and copies of the design drawings shall remain the property of the owner's designated representative for design and in no case shall the transfer of these CAD files or copies of design drawings be considered a sale.

- (b) The CAD files or copies of the design drawings shall not be considered to be contract documents. In the event of a conflict between the design drawings and the CAD files or copies thereof, the design drawings shall govern;
- (c) The use of CAD files or copies of the design drawings shall not in any way obviate the fabricator's responsibility for proper checking and coordination of dimensions, details, member sizes and fit-up and quantities of materials as required to facilitate the preparation of shop and erection drawings that are complete and accurate as required in Sec 4.2; and,
- (d) The fabricator shall remove information that is not required for the fabrication or erection of the structural steel from the CAD files or copies of the design drawings.

10.13.2.4 Approval

Except as provided in Sec 10.13.2.5, the shop and erection drawings shall be submitted to the owner's designated representatives for design and construction for review and approval. The shop and erection drawings shall be returned to the fabricator within 14 calendar days.

Final substantiating connection information, if any, shall also be submitted with the shop and erection drawings. The owner's designated representative for design is the final authority in the event of a disagreement between parties regarding connection design.

Approved shop and erection drawings shall be individually annotated by the owner's designated representatives for design and construction as either approved or approved subject to corrections noted. When so required, the fabricator shall subsequently make the corrections noted and furnish corrected shop and erection drawings to the owner's designated representatives for design and construction.

10.13.2.4.1 Constituents of approval

Approval of the shop and erection drawings, approval subject to corrections noted and similar approvals shall constitute the following:

- (a) Confirmation that the fabricator has correctly interpreted the contract documents in the preparation of those submittals;
- (b) Confirmation that the owner's designated representative for design has reviewed and approved the connection details shown on the shop and erection drawings and submitted in accordance with Sections 10.13.1 and 10.13.2, if applicable; and,

- (c) Release by the owner's designated representatives for design and construction for the fabricator to begin fabrication using the approved submittals.

Such approval shall not relieve the fabricator of the responsibility for either the accuracy of the detailed dimensions in the shop and erection drawings or the general fit-up of parts that are to be assembled in the field.

The fabricator shall determine the fabrication schedule that is necessary to meet the requirements of the contract.

10.13.2.4.2 Authorization by owner

Unless otherwise noted, any additions, deletions or revisions that are indicated in responses to RFIs or on the approved shop and erection drawings shall constitute authorization by the owner that the additions, deletions or revisions are released for construction. The fabricator and the erector shall promptly notify the owner's designated representative for construction when any direction or notation in responses to RFIs or on the shop or erection drawings or other information will result in an additional cost and/or a delay. See Sections 10.13.1.5 and 10.13.7.3.

10.13.2.5 Shop and/or erection drawings not furnished by the fabricator

When the shop and erection drawings are not prepared by the fabricator, but are furnished by others, they shall be delivered to the fabricator in a timely manner. These shop and erection drawings shall be prepared, insofar as is practical, in accordance with the shop fabrication and detailing standards of the fabricator. The fabricator shall neither be responsible for the completeness or accuracy of shop and erection drawings so furnished, nor for the general fit-up of the members that are fabricated from them.

10.13.2.6 The RFI process

When requests for information (RFIs) are issued, the process shall include the maintenance of a written record of inquiries and responses related to interpretation and implementation of the contract documents, including the clarifications and/or revisions to the contract documents that result, if any. RFIs shall not be used for the incremental release for construction of design drawings. When RFIs involve discrepancies or revisions, see Sections 10.13.1.3, 10.13.1.5, and 10.13.2.4.2.

10.13.2.7 Erection drawings

Erection drawings shall be provided to the erector in a timely manner so as to allow the erector to properly plan and perform the work.

10.13.3 Materials**10.13.3.1 Mill materials**

Unless otherwise noted in the contract documents, the fabricator is permitted to order the materials that are necessary for fabrication when the fabricator receives contract documents that have been released for construction.

Unless otherwise specified by means of special testing requirements in the contract documents, mill testing shall be limited to those tests that are required for the material in the ASTM specifications indicated in the contract documents. Materials ordered to special material requirements shall be marked by the supplier as specified in ASTM A6/A6M Section 12 prior to delivery to the fabricator's shop or other point of use. Such material not so marked by the supplier, shall not be used until:

- (a) Its identification is established by means of testing in accordance with the applicable ASTM specifications; and,
- (b) A fabricator's identification mark, as described in Sec 10.13.2 has been applied. When mill material does not satisfy ASTM A6/A6M tolerances for camber, profile, flatness or sweep, the fabricator shall be permitted to perform corrective procedures, including the use of controlled heating and/or mechanical straightening, subject to the limitations in the AISC Specification.

10.13.3.2 Stock materials

If used for structural purposes, materials that are taken from stock by the fabricator shall be of a quality that is at least equal to that required in the ASTM specifications indicated in the contract documents.

Material test reports shall be accepted as sufficient record of the quality of materials taken from stock by the fabricator. The fabricator shall review and retain the material test reports that cover such stock materials. However, the fabricator need not maintain records that identify individual pieces of stock material against individual material test reports, provided the fabricator purchases stock materials that meet the requirements for material grade and quality in the applicable ASTM specifications.

Stock materials that are purchased under no particular specification, under a specification that is less rigorous than the applicable ASTM specifications or without material test reports or other recognized test reports shall not be used without the approval of the owner's designated representative for design.

10.13.4 Fabrication

10.13.4.1 Cambering, curving and straightening

Local application of heat or mechanical means is permitted to be used to introduce or correct camber, curvature and straightness. The temperature of heated areas, as measured by approved methods, shall not exceed 593⁰ C for A514/A514M and A852/A852M steel nor 1,200⁰ F (649⁰ C) for other steels.

10.13.4.2 Thermal cutting

Thermally cut edges shall meet the requirements of AWS D1.1, Sections 5.15.1.2, 5.15.4.3 and 5.15.4.4 with the exception that thermally cut free edges that will be subject to calculated static tensile stress shall be free of round-bottom gouges greater than 5 mm deep and sharp V-shaped notches. Gouges deeper than 5 mm and notches shall be removed by grinding or repaired by welding.

Reentrant corners, except reentrant corners of *beam copes* and weld access holes, shall meet the requirements of AWS D1.1, Section A5.16. If another specified contour is required it must be shown on the contract documents.

Beam copes and weld access holes shall meet the geometrical requirements of Sec 10.10.1.6. Beam copes and weld access holes in shapes that are to be galvanized shall be ground. For shapes with a flange thickness not exceeding 50 mm the roughness of thermally cut surfaces of copes shall be no greater than a surface roughness value of 50 μ m as defined in ASME B46.1 Surface Texture (Surface Roughness, Waviness, and Lay). For beam copes and weld access holes in which the curved part of the access hole is thermally cut in ASTM A6/A6M hot-rolled shapes with a flange thickness exceeding 50 mm and welded built-up shapes with material thickness greater than 50 mm, a preheat temperature of not less than 66⁰ C shall be applied prior to thermal cutting. The thermally cut surface of access holes in ASTM A6/A6M hot-rolled shapes with a flange thickness exceeding 50 mm and built-up shapes with a material thickness greater than 50 mm shall be ground and inspected for cracks using magnetic particle inspection in accordance with ASTM E709. Any crack is unacceptable regardless of size or location.

10.13.4.3 Planing of edges

Planing or finishing of sheared or thermally cut edges of plates or shapes is not required unless specifically called for in the contract documents or included in a stipulated edge preparation for welding.

10.13.4.4 Welded construction

The technique of welding, the workmanship, appearance and quality of welds, and the methods used in correcting nonconforming work shall be in accordance with AWS D1.1 except as modified in Section J2.

10.13.4.5 Bolted construction

Parts of bolted members shall be pinned or bolted and rigidly held together during assembly. Use of a drift pin in bolt holes during assembly shall not distort the metal or enlarge the holes. Poor matching of holes shall be cause for rejection.

Bolt holes shall comply with the provisions of the RCSC Specification for Structural Joints Using ASTM A325 or A490 Bolts, Sec 10.13.3.3 except that thermally cut holes shall be permitted with a surface roughness profile not exceeding 25 μm as defined in ASME B46.1. Gouges shall not exceed a depth of 2 mm.

Fully inserted finger shims, with a total thickness of not more than 6 mm within a joint are permitted in joints without changing the strength (based upon hole type) for the design of connections. The orientation of such shims is independent of the direction of application of the load.

The use of high-strength bolts shall conform to the requirements of the RCSC Specification for Structural Joints Using ASTM A325 or A490 Bolts, except as modified in Sec 10.10.3.

10.13.4.6 Compression joints

Compression joints that depend on contact bearing as part of the splice strength shall have the bearing surfaces of individual fabricated pieces prepared by milling, sawing, or other suitable means.

10.13.4.7 Dimensional tolerances

Dimensional tolerances shall be in accordance with ASTM A6/A6M.

10.13.4.8 Finish of column bases

Column bases and base plates shall be finished in accordance with the following requirements:

- (1) Steel bearing plates 50 mm or less in thickness are permitted without milling, provided a satisfactory contact bearing is obtained. Steel bearing plates over 50 mm but not over 100 mm in thickness are permitted to be straightened by pressing or, if presses are not available, by milling for bearing surfaces (except as noted in subparagraphs 2 and 3 of

this Section), to obtain a satisfactory contact bearing. Steel bearing plates over 100 mm in thickness shall be milled for bearing surfaces (except as noted in subparagraphs 2 and 3 of this Section).

- (2) Bottom surfaces of bearing plates and column bases that are grouted to ensure full bearing contact on foundations need not be milled.
- (3) Top surfaces of bearing plates need not be milled when complete-joint- penetration groove welds are provided between the column and the bearing plate.

10.13.4.9 Holes for anchor rods

Holes for anchor rods shall be permitted to be thermally *cut* in accordance with the provisions of Sec 10.13.2.2.

10.13.4.10 Drain holes

When water can collect inside HSS or box members, either during construction or during service, the member shall be sealed, provided with a drain hole at the base, or protected by other suitable means.

10.13.4.11 Requirements for galvanized members

Members and parts to be galvanized shall be designed, detailed and fabricated to provide for flow and drainage of pickling fluids and zinc and to prevent pressure build-up in enclosed parts.

10.13.5 Shop Painting

10.13.5.1 General requirements

Shop paint is not required unless specified by the contract documents.

10.13.5.2 Inaccessible surfaces

Except for contact surfaces, surfaces inaccessible after shop assembly shall be cleaned and painted prior to assembly, if required by the design documents.

10.13.5.3 Contact surfaces

Paint is permitted in bearing-type connections. For slip-critical connections, the faying surface requirements shall be in accordance with the RCSC Specification for Structural Joints Using ASTM A325 or A490 Bolts, Section 3.2.2(b).

10.13.5.4 Finished surfaces

Machine-finished surfaces shall be protected against corrosion by a rust inhibitive coating that can be removed prior to erection, or which has characteristics that make removal prior to erection unnecessary.

10.13.5.5 Surfaces adjacent to field welds

Unless otherwise specified in the design documents, surfaces within 50 mm of any field weld location shall be free of materials that would prevent proper welding or produce objectionable fumes during welding.

10.13.6 Erection

10.13.6.1 Alignment of column bases

Column bases shall be set level and to correct elevation with full bearing on concrete or masonry.

10.13.6.2 Bracing

The frame of steel skeleton buildings shall be carried up true and plumb. Temporary bracing shall be provided, wherever necessary to support the loads to which the structure may be subjected, including equipment and the operation of same. Such bracing shall be left in place as long as required for safety.

10.13.6.3 Alignment of structural elements

No permanent bolting or welding shall be performed until the adjacent affected portions of the structure have been properly aligned.

10.13.6.4 Fit of column compression joints and base plates

Lack of contact bearing not exceeding a gap of 2 mm, regardless of the type of splice used (partial-joint-penetration groove welded or bolted), is permitted. If the gap exceeds 2 mm, but is less than 6 mm, and if an engineering investigation shows that sufficient contact area does not exist, the gap shall be packed out with nontapered steel shims. Shims need not be other than mild steel, regardless of the grade of the main material.

10.13.6.5 Field welding

Shop paint on surfaces adjacent to joints to be field welded shall be wire brushed if necessary to assure weld quality.

Field welding of attachments to installed embedments in contact with concrete shall be done in such a manner as to avoid excessive thermal expansion of the embedment which could result in spalling or cracking of the concrete or excessive stress in the embedment anchors.

10.13.6.6 Field painting

Responsibility for touch-up painting, cleaning and field painting shall be allocated in accordance with accepted local practices, and this allocation shall be set forth explicitly in the design documents.

10.13.6.7 Connections

As erection progresses, the structure shall be securely bolted or welded to support dead, wind and erection loads.

10.13.7 Quality Control

The fabricator shall provide quality control procedures to the extent that the fabricator deems necessary to assure that the work is performed in accordance with this Specification. In addition to the fabricator's quality control procedures, material and workmanship at all times may be subject to inspection by qualified inspectors representing the purchaser. If such inspection by representatives of the purchaser will be required, it shall be so stated in the design documents.

10.13.7.1 Cooperation

As far as possible, the inspection by representatives of the purchaser shall be made at the fabricator's plant. The fabricator shall cooperate with the inspector, permitting access for inspection to all places where work is being done. The purchaser's inspector shall schedule this work for minimum interruption to the work of the fabricator.

10.13.7.2 Rejections

Material or workmanship not in conformance with the provisions of this Specification may be rejected at any time during the progress of the work.

The fabricator shall receive copies of all reports furnished to the purchaser by the inspection agency.

10.13.7.3 Inspection of welding

The inspection of welding shall be performed in accordance with the provisions of AWS D1.1 except as modified in Sec 10.10.2.

When visual inspection is required to be performed by AWS certified welding inspectors, it shall be so specified in the design documents.

When nondestructive testing is required, the process, extent and standards of acceptance shall be clearly defined in the design documents.

10.13.7.4 Inspection of slip-critical high-strength bolted connections

The inspection of slip-critical high-strength bolted connections shall be in accordance with the provisions of the RCSC Specification for Structural Joints Using ASTM A325 or A490 Bolts.

10.13.7.5 Identification of steel

The fabricator shall be able to demonstrate by a written procedure and by actual practice a method of material identification, visible at least to the “fit-up” operation, for the main structural elements of each shipping piece.

10.14 Direct Analysis Method

This Section addresses the direct analysis method for structural systems comprised of moment frames, braced frames, shear walls, or combinations thereof.

10.14.1 General Requirements

Members shall satisfy the provisions of Sec 10.8.1 with the nominal column strengths, P_n , determined using $K = 1.0$. The required strengths for members, connections and other structural elements shall be determined using a second-order elastic analysis with the constraints presented in Sec 10.14.3. All component and connection deformations that contribute to the lateral displacement of the structure shall be considered in the analysis.

10.14.2 Notional Loads

Notional loads shall be applied to the lateral framing system to account for the effects of geometric imperfections, inelasticity, or both. Notional loads are lateral loads that are applied at each framing level and specified in terms of the gravity loads applied at that level. The gravity load used to determine the notional load shall be equal to or greater than the gravity load associated with the load combination being evaluated. Notional loads shall be applied in the direction that adds to the destabilizing effects under the specified load combination.

10.14.3 Design-Analysis Constraints

- (1) The second-order analysis shall consider both $P-\delta$ and $P-\Delta$ effects. It is permitted to perform the analysis using any general second-order analysis method, or by the amplified first-order analysis method of Sec 10.3.2, provided that the B_1 and B_2

factors are based on the reduced stiffnesses defined in Eq. 6.10.263 and 6.10.264. Analyses shall be conducted according to the design and loading requirements specified in either Sec 10.2.3.3 (LRFD) or Sec 10.2.3.4 (ASD). For ASD, the second-order analysis shall be carried out under 1.6 times the ASD load combinations and the results shall be divided by 1.6 to obtain the required strengths.

Methods of analysis that neglect the effects of $P - \delta$ on the lateral displacement of the structure are permitted where the axial loads in all members whose flexural stiffnesses are considered to contribute to the lateral stability of the structure satisfy the following limit:

$$\alpha P_r < 0.15 P_{eL} \quad (6.10.262)$$

Where,

P_r = required axial compressive strength under LRFD or ASD load combinations, N

$P_{eL} = \pi^2 EI/L^2$ evaluated in the plane of bending

And, $\alpha = 1.0$ (LRFD) $\alpha = 1.6$ (ASD)

- (2) A notional load, $N_i = 0.002Y_i$, applied independently in two orthogonal directions, shall be applied as a lateral load in all load combinations. This load shall be in addition to other lateral loads, if any,

Where,

N_i = notional lateral load applied at level i , N

Y_i = gravity load from LRFD load combination or 1.6 times the ASD load combination applied at level i , N

The notional load coefficient of 0.002 is based on an assumed initial story out-of-plumbness ratio of 1/500. Where a smaller assumed out-of-plumbness is justified, the notional load coefficient may be adjusted proportionally.

For frames where the ratio of second-order drift to first-order drift is equal to or less than 1.5, it is permissible to apply the notional load, N_i , as a minimum lateral load for the gravity-only load combinations and not in combination with other lateral loads.

For all cases, it is permissible to use the assumed out-of-plumbness geometry in the analysis of the structure in lieu of applying a notional load or a minimum lateral load as defined above.

- (3) A reduced flexural stiffness, EI^* ,

$$EI^* = 0.8\tau_b EI \quad (6.10.263)$$

shall be used for all members whose flexural stiffness is considered to contribute to the lateral stability of the structure,

Where,

I = moment of inertia about the axis of bending, mm^4

$\tau_b = 1.0$ for $\alpha P_r/P_y \leq 0.5$

$= 4[\alpha P_r/P_y(1 - \alpha P_r/P_y)]$ for $\alpha P_r/P_y > 0.5$

P_r = required axial compressive strength under *LRFD* or *ASD load combinations*, N

$P_y = AF_y$, member yield strength, N

And $\alpha = 1.0$ (LRFD) $\alpha = 1.6$ (ASD)

In lieu of using $\tau_b < 1.0$, where, $\alpha P_r/P_y > 0.5$, $\tau_b = 1.0$ may be used for all members, provided that an additive notional load of $0.001 Y_i$ is added to the notional load required in (2).

- (4) A reduced axial stiffness, EA^* ,

$$EA^* = 0.8 EA \quad (6.10.264)$$

shall be used for members whose axial stiffness is considered to contribute to the lateral stability of the structure, where A is the cross-sectional member area.

10.15 Inelastic Analysis and Design

10.15.1 General Provisions

Inelastic analysis is permitted for design according to the provisions of Sec 10.2.3.3 (LRFD). Inelastic analysis is not permitted for design according to the provisions of Sec 10.2.3.4 (ASD) except as provided in Sec 10.15.3.

10.15.2 Materials

Members undergoing plastic hinging shall have a specified minimum yield stress not exceeding 450 MPa.

10.15.3 Moment Redistribution

Beams and girders composed of compact sections as defined in Sec 10.2.4 and satisfying the unbraced length requirements of Sec 10.15.7, including composite members, may be proportioned for nine-tenths of the negative moments at points of support, produced by the gravity loading computed by an elastic analysis, provided that the maximum positive moment is increased by one-tenth of the average negative moments. This reduction is not permitted for moments produced by loading on cantilevers and for design according to Sections 10.15.4 to 10.15.8 of this Section.

If the negative moment is resisted by a *column* rigidly framed to the beam or girder, the one-tenth reduction may be used in proportioning the column for combined axial *force* and flexure, provided that the axial force does not exceed $1.5\phi_c F_y A_g$ for LRFD or $0.15F_y A_g / \Omega_c$ for ASD,

Where,

A_g = gross area of member, mm²

F_y = specified minimum yield stress of the compression flange, MPa.

ϕ_c = resistance factor for compression = 0.90

Ω_c = safety factor for compression = 1.67

10.15.4 Local Buckling

Flanges and webs of members subject to plastic hinging in combined flexure and axial compression shall be compact with width-thickness ratios less than or equal to the limiting λ_p defined in Table 6.10.1 or as modified as follows:

- (a) For webs of doubly symmetric wide flange members and rectangular HSS in combined flexure and compression

- (i) For $P_u/(\phi_b P_y) \leq 0.125$

$$h/t_w \leq 3.76 \sqrt{\frac{E}{F_y}} \left(1 - \frac{2.75 P_u}{\phi_b P_y}\right) \quad (6.10.265)$$

- (ii) For $P_u/\phi_b P_y > 0.125$

$$h/t_w \leq 1.12 \sqrt{\frac{E}{F_y}} \left(2.33 - \frac{P_u}{\phi_b P_y}\right) \geq 1.49 \sqrt{\frac{E}{F_y}} \quad (6.10.266)$$

Where,

E = modulus of elasticity of steel 200 000 MPa.

F_y = specified minimum yield stress of the type of steel being used, MPa.

h = as defined in Sec 10.2.4.2, mm.

P_u = required axial strength in compression, N.

P_y = member yield strength, N.

t_w = web thickness, mm.

ϕ_b = resistance factor for flexure = 0.90

- (b) For flanges of rectangular box and hollow structural sections of uniform thickness subject to bending or compression, flange cover plates, and diaphragm plates between lines of fasteners or welds

$$b/t \leq 0.94 \sqrt{E/F_y} \quad (6.10.267)$$

Where,

b = as defined in Sec 10.2.4.2, mm.

t = as defined in Sec 10.2.4.2, mm.

- (c) For circular hollow sections in flexure

$$D/t \leq 0.045 E/F_y \quad (6.10.268)$$

Where,

D = outside diameter of round HSS member, mm.

10.15.5 Stability and Second-Order Effects

Continuous beams not subjected to axial loads and that do not contribute to lateral stability of framed structures may be designed based on a first-order inelastic analysis or a plastic mechanism analysis.

Braced frames and moment frames may be designed based on a first-order inelastic analysis or a plastic mechanism analysis provided that stability and second-order effects are taken into account.

Structures may be designed on the basis of a second-order inelastic analysis. For beam-columns, connections and connected members, the required strengths shall be determined from a second-order inelastic analysis, where equilibrium is satisfied on deformed geometry, taking into account the change in stiffness due to yielding

10.15.5.1 Braced frames

In braced frames designed on the basis of inelastic analysis, braces shall be designed to remain elastic under the design loads. The required axial strength for columns and compression braces shall not exceed $\phi_c 0.85 F_y A_g$,

Where, $\phi_c = 0.90$ (LRFD)

10.15.5.2 Moment frames

In moment frames designed on the basis of inelastic analysis, the required axial strength of columns shall not exceed $\phi_c 0.75 F_y A_g$

Where, $\phi_c = 0.90$ (LRFD)

10.15.6 Columns and Other Compression Members

In addition to the limits set in Sections 10.15.5.1 and 10.15.5.2, the required axial strength of columns designed on the basis of inelastic analysis shall not exceed the design strength, $\phi_c P_n$, determined according to the provisions of Sec 10.5.3.

Design by inelastic analysis is permitted if the column slenderness ratio, L/r , does not exceed $4.71\sqrt{E/F_y}$,

Where,

L = laterally unbraced length of a member, mm.

r = governing radius of gyration, mm.

10.15.7 Beams and Other Flexural Members

The required moment strength, M_u , of beams designed on the basis of inelastic analysis shall not exceed the design strength, ϕM_n , where

$$M_n = M_p = F_y Z < 1.6 F_y S \quad (6.10.269)$$

$$\phi_c = 0.90 \text{ (LRFD)}$$

- (a) For doubly symmetric and singly symmetric I-shaped members with the compression flange equal to or larger than the tension flange loaded in the plane of the web:

$$L_{pd} = \left[0.12 + 0.076 \left(\frac{M_1}{M_2} \right) \right] \left(\frac{E}{F_y} \right) r_y \quad (6.10.270)$$

Where,

M_1 = smaller moment at end of unbraced length of beam, N-mm

M_2 = larger moment at end of unbraced length of beam, N-mm

r_y = radius of gyration about minor axis, mm

$(M_1 \times M_2)$ is positive when moments cause reverse curvature and negative for single curvature.

- (b) For solid rectangular bars and symmetric box beams:

$$L_{pd} = \left[0.17 + 0.10 \left(\frac{M_1}{M_2} \right) \right] \left(\frac{E}{F_y} \right) r_y \geq 0.10 \left(\frac{E}{F_y} \right) r_y \quad (6.10.271)$$

There is no limit on L_b for members with circular or square cross sections or for any beam bent about its minor axis.

10.15.8 Members under Combined Forces

When inelastic analysis is used for symmetric members subject to bending and axial force, the provisions in Sec 10.8.1 apply.

Inelastic analysis is not permitted for members subject to torsion and combined torsion, flexure, shear and/or axial force.\

10.15.9 Connections

Connections adjacent to plastic hinging regions of connected members shall be designed with sufficient strength and ductility to sustain the forces and deformations imposed under the required loads.

10.16 Design for Ponding

This Section provides methods for determining whether a roof system has adequate strength and stiffness to resist ponding.

10.16.1 Simplified Design for Ponding

The roof system shall be considered stable for ponding and no further investigation is needed if both of the following two conditions are met:

$$C_p + 0.9 C_s \leq 0.25 \quad (6.10.272)$$

$$I_d \geq 3940 S^4 \quad (6.10.273)$$

Where,

$$C_p = \frac{504 L_s L_p^4}{I_p}$$

$$C_s = \frac{504 S L_s^4}{I_s}$$

L_p = column spacing in direction of girder (length of primary members), m.

L_s = column spacing perpendicular to direction of girder (length of secondary members), m.

S = spacing of secondary members, m.

I_p = moment of inertia of primary members, mm^4 .

I_s = moment of inertia of secondary members, mm^4 .

I_d = moment of inertia of the steel deck supported on secondary members, mm^4 per m.

For trusses and steel joists, the moment of inertia I_s shall be decreased 15 percent when used in the above equation. A steel deck shall be considered a secondary member when it is directly supported by the primary members.

10.16.2 Improved Design for Ponding

The provisions given below are permitted to be used when a more exact determination of framing stiffness is needed than that given in Sec 10.16.1.

For primary members, the stress index shall be

$$U_p = \left(\frac{0.8F_y - f_o}{f_o} \right)_p \quad (6.10.274)$$

For secondary members, the stress index shall be

$$U_s = \left(\frac{0.8F_y - f_o}{f_o} \right)_s \quad (6.10.275)$$

Where,

f_o = stress due to the load combination ($D + R$)

D = nominal dead load

R = nominal load due to rainwater or snow, exclusive of the ponding contribution, MPa.

For roof framing consisting of primary and secondary members, the combined stiffness shall be evaluated as follows: enter Figure 6.10.1 at the level of the computed stress index U_p determined for the primary beam; move horizontally to the computed C_s value of the secondary beams and then downward to the abscissa scale. The combined stiffness of the primary and secondary framing is sufficient to prevent ponding if the flexibility constant read from this latter scale is more than the value of C_p computed for the given primary member; if not, a stiffer primary or secondary beam, or combination of both, is required.

A similar procedure must be followed using Figure 6.10.2.

For roof framing consisting of a series of equally spaced wall-bearing beams, the stiffness shall be evaluated as follows. The beams are considered as secondary members supported on an infinitely stiff primary member. For this case, enter Figure 6.10.2 with the computed stress index U_s . The limiting value of C_s is determined by the intercept of a horizontal line representing the U_s value and the curve for $C_p = 0$.

For roof framing consisting of metal deck spanning between beams supported on columns, the stiffness shall be evaluated as follows. Employ Figure 6.10.1 or 6.10.2 using as C_s the flexibility constant for a 1 m width of the roof deck ($S = 1.0$).

10.17 Design for Fatigue

This Section applies to members and connections subject to high cyclic loading within the elastic range of stresses of frequency and magnitude sufficient to initiate cracking and progressive failure, which defines the limit state of fatigue.

10.17.1 General

The provisions of this Section apply to stresses calculated on the basis of service loads. The maximum permitted stress due to unfactored loads is $0.66F_y$.

Stress range is defined as the magnitude of the change in stress due to the application or removal of the service live load. In the case of a stress reversal, the stress range shall be computed as the numerical sum of maximum repeated tensile and compressive stresses or the numerical sum of maximum shearing stresses of opposite direction at the point of probable crack initiation.

In the case of complete-joint-penetration butt welds, the maximum design stress range calculated by Eq. 6.10.276 applies only to welds with internal soundness meeting the acceptance requirements of Sec 6.12.2 or Sec 6.13.2 of AWS D1.1.

No evaluation of fatigue resistance is required if the live load stress range is less than the threshold stress range, FTH. See Table 6.10.14.

No evaluation of fatigue resistance is required if the number of cycles of application of live load is less than 20,000.

The cyclic load resistance determined by the provisions of this Section is applicable to structures with suitable corrosion protection or subject only to mildly corrosive atmospheres, such as normal atmospheric conditions.

The cyclic load resistance determined by the provisions of this Section is applicable only to structures subject to temperatures not exceeding 150° C.

The engineer of record shall provide either complete details including weld sizes or shall specify the planned cycle life and the maximum range of moments, shears and reactions for the connections.

10.17.2 Calculation of Maximum Stresses and Stress Ranges

Calculated stresses shall be based upon elastic analysis. Stresses shall not be amplified by stress concentration factors for geometrical discontinuities.

For bolts and threaded rods subject to axial tension, the calculated stresses shall include the effects of prying action, if any. In the case of axial stress combined with bending, the maximum stresses, of each kind, shall be those determined for concurrent arrangements of the applied load.

For members having symmetric cross sections, the fasteners and welds shall be arranged symmetrically about the axis of the member, or the total stresses including those due to eccentricity shall be included in the calculation of the stress range.

For axially loaded angle members where the center of gravity of the connecting welds lies between the line of the center of gravity of the angle cross section and the center of the connected leg, the effects of eccentricity shall be ignored. If the center of gravity of the connecting welds lies outside this zone, the total stresses, including those due to joint eccentricity, shall be included in the calculation of stress range.

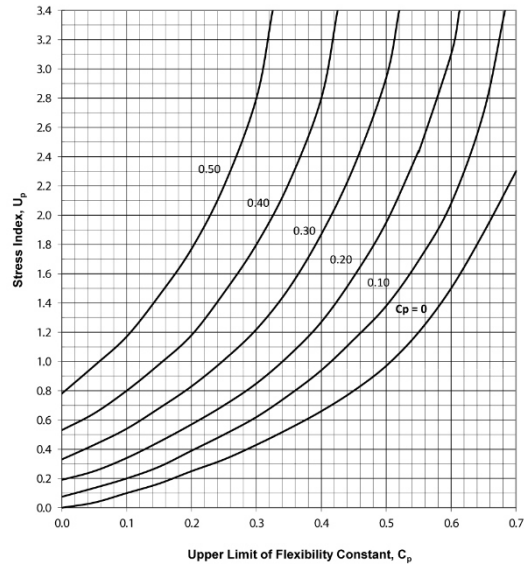


Figure 6.10.1 Limiting flexibility coefficient for the primary systems

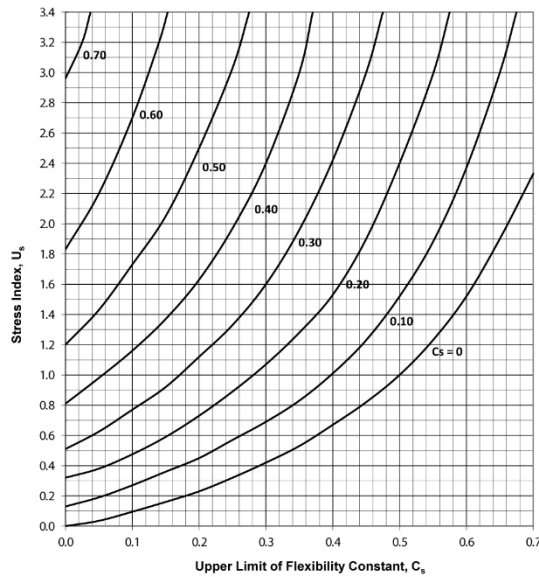


Figure 6.10.2 Limiting flexibility coefficient for the secondary systems.

10.17.3 Design Stress Range

The range of stress at service loads shall not exceed the design stress range computed as follows.

- (a) For stress categories A, B, B', C, D, E and E' (see Table 6.10.14) the design stress range, F_{SR} , shall be determined by Eq. 10.17.3.1 or 10.17.3.2.

$$F_{SR} = \left(\frac{C_f \times 329}{N} \right)^{0.333} \geq F_{TH} \quad (6.10.276)$$

Where,

F_{SR} = design stress range, MPa.

C_f = constant from Table 6.10.14 for the category

N = number of stress range fluctuations in design life

= number of stress range fluctuations per day \times 365 \times years of design life

F_{TH} = threshold fatigue stress (MPa) range, maximum stress range for indefinite design life from Table 6.10.14.

- (b) For stress category F, the design stress range, F_{SR} , shall be determined by Eq. 6.10.277.

$$F_{SR} = \left(\frac{C_f \times 11 \times 10^4}{N} \right)^{0.167} \geq F_{TH} \quad (6.10.277)$$

- (c) For tension-loaded plate elements connected at their end by cruciform, T, or corner details with complete-joint-penetration (CJP) groove welds or partial-joint-penetration (PJP) groove welds, fillet welds, or combinations of the preceding, transverse to the direction of stress, the design stress range on the cross section of the tension-loaded plate element at the toe of the weld shall be determined as follows:

- (i) Based upon crack initiation from the toe of the weld on the tension loaded plate element the design stress range, F_{SR} , shall be determined by Eq. 10.17.3.3 for stress category C which is equal to

$$F_{SR} = \left(\frac{14.4 \times 10^{11}}{N} \right)^{0.333} \geq 68.9 \quad (6.10.278)$$

- (ii) Based upon crack initiation from the root of the weld the design stress range, FSR, on the tension loaded plate element using transverse PJP groove welds, with or without reinforcing or contouring fillet welds, the design stress range on the cross section at the toe of the weld shall be determined by Eq. 10.17.3.4, stress category C' as follows:

$$F_{SR} = R_{PJP} \left(\frac{14.4 \times 10^{11}}{N} \right)^{0.333} \quad (6.10.279)$$

Where, R_{PJP} is the reduction factor for reinforced or nonreinforced transverse PJP groove welds determined as follows:

$$R_{PJP} = \left(\frac{1.12 - 1.01 \left(\frac{2a}{t_p} \right) + 1.24 \left(\frac{w}{t_p} \right)}{t_p^{0.167}} \right) \leq 1.0 \quad (6.10.280)$$

If $R_{PJP} = 1.0$, use stress category C.

$2a$ = the length of nonwelded root face in the direction of the thickness of the tension-loaded plate, mm.

W = the leg size of the reinforcing or contouring fillet, if any, in the direction of the thickness of the tension-loaded plate, mm.

t_p = thickness of tension loaded plate, mm.

- (iii) Based upon crack initiation from the roots of a pair of transverse fillet welds on opposite sides of the tension loaded plate element the design stress range, FSR, on the cross section at the toe of the welds shall be determined by Eq. 10.17.3.5, stress category C'' as follows:

$$F_{SR} = R_{FIL} \left(\frac{14.4 \times 10^{11}}{N} \right)^{0.333} \quad (6.10.281)$$

Where, R_{FIL} is the reduction factor for joints using a pair of transverse fillet welds only.

$$R_{FIL} = \left(\frac{0.10 + 1.24(w/t_p)}{t_p^{0.167}} \right) \leq 1.0 \quad (6.10.282)$$

If $R_{FIL} = 1.0$, use stress category C.

10.17.4 Bolts and Threaded Parts

The range of stress at service loads shall not exceed the stress range computed as follows.

- For mechanically fastened connections loaded in shear, the maximum range of stress in the connected material at service loads shall not exceed the design stress range computed using Eq. 6.10.276 where C_f and FTH are taken from Section 2 of Table 6.10.14.
- For high-strength bolts, common bolts, and threaded anchor rods with cut, ground or rolled threads, the maximum range of tensile stress on the net tensile area from applied axial load and moment plus load due to prying action shall not exceed the design stress range computed using Eq. 6.10.276. The factor C_f shall be taken as 3.9×10^8 (as for stress category E'). The threshold stress, FTH shall be taken as 48 MPa (as for stress category D). The net tensile area is given by Eq. 6.10.283.

$$A_t = \frac{\pi}{4} (d_b - 0.9382P)^2 \quad (6.10.283)$$

Where,

P = pitch, mm per thread

d_b = the nominal diameter (body or shank diameter), mm.

n = threads per mm.

For joints in which the material within the grip is not limited to steel or joints which are not tensioned to the requirements of Table 6.10.9, all axial load and moment applied to the joint plus effects of any prying action shall be assumed to be carried exclusively by the bolts or rods.

For joints in which the material within the grip is limited to steel and which are tensioned to the requirements of Table 6.10.9, an analysis of the relative stiffness of the connected parts and bolts shall be permitted to be used to determine the tensile stress range in the pretensioned bolts due to the total service live load and moment plus effects of any prying action. Alternatively, the stress range in the bolts shall be assumed to be equal to the stress on the net tensile area due to 20 percent of the absolute value of the service load axial load and moment from dead, live and other loads.

10.17.5 Special Fabrication and Erection Requirements

Longitudinal backing bars are permitted to remain in place, and if used, shall be continuous. If splicing is necessary for long joints, the bar shall be joined with complete penetration butt joints and the reinforcement ground prior to assembly in the joint.

Transverse joints subject to tension, backing bars, if used, shall be removed and joint back gouged and welded.

In transverse complete-joint-penetration T and corner joints, a reinforcing fillet weld, not less than 6 mm in size shall be added at re-entrant corners.

The surface roughness of flame cut edges subject to significant cyclic tensile stress ranges shall not exceed 25 μm , where ASME B46.1 is the reference standard.

Reentrant corners at cuts, *copies* and weld access holes shall form a radius of not less than 10 mm by predrilling or subpunching and reaming a hole, or by thermal cutting to form the radius of the cut. If the radius portion is formed by thermal cutting, the cut surface shall be ground to a bright metal surface.

For transverse butt joints in regions of high tensile stress, run-off tabs shall be used to provide for cascading the weld termination outside the finished joint. End dams shall not be used. Run-off tabs shall be removed and the end of the weld finished flush with the edge of the member.

See Sec 10.10.2.2 for requirements for end returns on certain fillet welds subject to cyclic service loading.

Table 6.10.14a: Fatigue Design Parameters

Description	Stress Category	Constant C_f	Threshold F_{TH} (MPa)	Potential Crack Initiation Point
SECTION 1 – PLAIN MATERIAL AWAY FROM ANY WELDING				
1.1 Base metal, except non-coated weathering steel, with rolled or cleaned surface. Flame-cut edges with surface roughness value of 25 μm or less, but without reentrant corners.	A	250×10^8	165	Away from all welds or structural connections
1.2 Non-coated weathering steel base metal with rolled or cleaned surface. Flame-cut edges with surface roughness value of 25 μm or less, but without reentrant corners.	B	120×10^8	110	Away from all welds or structural connections

Description	Stress Category	Constant C_f	Threshold F_{TH} (MPa)	Potential Crack Initiation Point
1.3 Member with drilled or reamed holes. Member with reentrant corners at <i>copies</i> , cuts, block-outs or other geometrical discontinuities made to requirements of Sec 10.17.3.5, except weld access holes.	B	120×10^8	110	At any external edge or at hole perimeter
1.4 Rolled cross sections with weld access holes made to requirements of Sec 10.10.1.6 and Sec 10.17.3.5. Members with drilled or reamed holes containing bolts for attachment of light bracing where there is a small longitudinal component of brace force.	C	44×10^8	69	At reentrant corner of weld access hole or at any small hole (may contain bolt for minor connections)
SECTION 2– CONNECTED MATERIAL IN MECHANICALLY FASTENED JOINTS				
2.1 Gross area of base metal in lap joints connected by high-strength bolts in joints satisfying all requirements for slip-critical connections.	B	120×10^8	110	Through gross section near hole
2.2 Base metal at net section of high-strength bolted joints, designed on the basis of bearing resistance, but fabricated and installed to all requirements for slip-critical connections.	B	120×10^8	110	In net section originating at side of hole
2.3 Base metal at the net section of other mechanically fastened joints except eye bars and pin plates.	D	22×10^8	48	In net section originating at side of hole
2.4 Base metal at net section of eye bar head or pin plate.	E	11×10^8	31	In net section originating at side of hole

Description	Stress Category	Constant C_f	Threshold F_{TH} (MPa)	Potential Crack Initiation Point
SECTION 3 – WELDED JOINTS JOINING COMPONENTS OF BUILT-UP MEMBERS				
3.1 Base metal and weld metal in members without attachments built-up of plates or shapes connected by continuous longitudinal complete-joint-penetration groove welds, back gouged and welded from second side, or by continuous fillet welds.	B	120×10^8	110	From surface or internal discontinuities in weld away from end of weld
3.2 Base metal and weld metal in members without attachments built-up of plates or shapes, connected by continuous longitudinal complete-joint-penetration groove welds with backing bars not re-moved, or by continuous partial-joint-penetration groove welds.	B	61×10^8	83	From surface or internal discontinuities in weld, including weld attaching backing bars
3.3 Base metal and weld metal termination of longitudinal welds at weld access holes in connected built-up members.	D	22×10^8	48	From the weld termination into the web or flange
3.4 Base metal at ends of longitudinal intermittent fillet weld segments.	E	11×10^8	31	In connected material at start and stop locations of any weld deposit
3.5 Base metal at ends of partial length welded cover plates narrower than the flange having square or tapered ends, with or without welds across the ends of cover plates wider than the flange with welds across the ends.	E E'			In flange at toe of end weld or in flange at termination of longitudinal weld or in edge of flange with wide cover plates
Flange thickness ≤ 20 mm		11×10^8	31	
Flange thickness > 20 mm		3.9×10^8	18	

Description	Stress Category	Constant C_f	Threshold F_{TH} (MPa)	Potential Crack Initiation Point
3.6 Base metal at ends of partial length welded cover plates wider than the flange without welds across the ends.	E'	3.9×10^8	18	In edge of flange at end of cover plate weld
SECTION 4 – LONGITUDINAL FILLET WELDED END CONNECTIONS				
4.1 Base metal at junction of axially loaded members with longitudinally welded end connections. Welds shall be on each side of the axis of the member to balance weld stresses.				Initiating from end of any weld termination extending into the base metal.
$t \leq 20$ mm	E	11×10^8	31	
$t > 20$ mm	E'	3.9×10^8	18	
SECTION 5 – WELDED JOINTS TRANSVERSE TO DIRECTION OF STRESS				
5.1 Base metal and weld metal in or adjacent to complete-joint-penetration groove welded splices in rolled or welded cross sections with welds ground essentially parallel to the direction of stress.	B	120×10^8	110	From internal discontinuities in filler metal or along the fusion boundary
5.2 Base metal and weld metal in or adjacent to complete-joint-penetration groove welded splices with welds ground essentially parallel to the direction of stress at transitions in thickness or width made on a slope no greater than 8 to 20%.				From internal discontinuities in filler metal or along fusion boundary or at start of transition when $F_y \geq 620$ MPa
$F_y < 620$ MPa	B	120×10^8	110	
$F_y \geq 620$ MPa	B'	61×10^8	83	

Description	Stress Category	Constant C_f	Threshold F_{TH} (MPa)	Potential Crack Initiation Point
5.3 Base metal with F_y equal to or greater than 620 MPa and weld metal in or adjacent to complete-joint-penetration groove welded splices with welds ground essentially parallel to the direction of stress at transitions in width made on a radius of not less than 600 mm with the point of tangency at the end of the groove weld.	B	120×10^8	110	From internal discontinuities in filler metal or discontinuities along the fusion boundary
5.4 Base metal and weld metal in or adjacent to the toe of complete-joint-penetration T or corner joints or splices, with or without transitions in thickness having slopes no greater than 8 to 20%, when weld reinforcement is not removed.	C	44×10^8	69	From surface discontinuity at toe of weld extending into base metal or along fusion boundary.
5.5 Base metal and weld metal at transverse end connections of tension-loaded plate elements using partial-joint-penetration butt or T or corner joints, with reinforcing or contouring fillets, FSR shall be the smaller of the toe crack or root crack stress range.				Initiating from geometrical discontinuity at toe of weld extending into base metal or, initiating at weld root subject to tension extending up and then out through weld
Crack initiating from weld toe:	C	44×10^8	69	
Crack initiating from weld root:	C'	Eq. 6.10.279	None provided	

Description	Stress Category	Constant C_f	Threshold F_{TH} (MPa)	Potential Crack Initiation Point
5.6 Base metal and filler metal at transverse end connections of tension-loaded plate elements using a pair of fillet welds on opposite sides of the plate. FSR shall be the smaller of the toe crack or root crack stress range.				Initiating from geometrical discontinuity at toe of weld extending into base metal or, initiating at <i>weld root</i> subject to tension extending up and then out through weld
Crack initiating from weld toe:	C	44×10^8	69	
Crack initiating from weld root:	C'	Eq. 6.10.280	None provided	
5.7 Base metal of tension loaded plate elements and on girders and rolled beam webs or flanges at toe of transverse fillet welds adjacent to welded transverse stiffeners.	C	44×10^8	69	From geometrical discontinuity at <i>toe of fillet</i> extending into base metal
SECTION 6 – BASE METAL AT WELDED TRANSVERSE MEMBER CONNECTIONS				
6.1 Base metal at details attached by complete joint penetration groove welds subject to longitudinal loading only when the detail embodies a transition radius R with the weld termination ground smooth.				Near point of tangency of radius at edge of member
$R \geq 600$ mm	B	120×10^8	110	
$600 \text{ mm} > R \geq 150$ mm	C	44×10^8	69	
$150 \text{ mm} > R \geq 50$ mm	D	22×10^8	48	
$50 \text{ mm} > R$	E	11×10^8	31	

Description	Stress Category	Constant C_f	Threshold F_{TH} (MPa)	Potential Crack Initiation Point
6.2 Base metal at details of equal thickness attached by complete-joint-penetration groove welds subject to trans-verse loading with or without longitudinal loading when the detail embodies a transition radius R with the weld termination ground smooth:				
When weld reinforcement is removed:				
$R \geq 600$ mm	B	120×10^8	110	Near points of tangency of radius or in the weld or at fusion boundary or member or attachment
$600 \text{ mm} > R \geq 150$ mm	C	44×10^8	69	
$150 \text{ mm} > R \geq 50$ mm	D	22×10^8	48	
$50 \text{ mm} > R$	E	11×10^8	31	
When weld reinforcement is not removed:				
$R \geq 600$ mm	C	44×10^8	69	At toe of the weld either along edge of member or the attachment
$600 \text{ mm} > R \geq 150$ mm	C	44×10^8	69	
$150 \text{ mm} > R \geq 50$ mm	D	22×10^8	48	
$50 \text{ mm} > R$	E	11×10^8	31	
6.3 Base metal at details of unequal thickness attached by complete-joint-penetration groove welds subject to trans-verse loading with or without longitudinal loading when the detail embodies a transition radius R with the weld termination ground smooth.				

Description	Stress Category	Constant C_f	Threshold F_{TH} (MPa)	Potential Crack Initiation Point
When weld reinforcement is removed: $R > 50$ mm $R \leq 50$ mm When reinforcement is not removed: Any radius	D E E	22×10^8 11×10^8 11×10^8	48 31 31	At toe of weld along edge of thinner material In weld termination in small radius At toe of weld along edge of thinner material
6.4 Base metal subject to longitudinal stress at transverse members, with or without transverse stress, attached by fillet or partial penetration groove welds parallel to direction of stress when the detail embodies a transition radius, R , with weld termination ground smooth: $R > 50$ mm $R \leq 50$ mm	D E	22×10^8 11×10^8	48 31	In weld termination or from the toe of the weld extending into member
SECTION 7 – BASE METAL AT SHORT ATTACHMENTS¹				
7.1 Base metal subject to longitudinal loading at details attached by fillet welds parallel or trans-verse to the direction of stress where the detail embodies no transition radius and with detail length in direction of stress, a , and attachment height normal to the surface of the member, b :				In the member at the end of the weld

Description	Stress Category	Constant C_f	Threshold F_{TH} (MPa)	Potential Crack Initiation Point
$a < 50$ mm	C	44×10^8	69	
$50 \text{ mm} \leq a \leq 12b$ or 100 mm	D	22×10^8	48	
$a > 12b$ or 100 mm when b is ≤ 25 mm	E	11×10^8	31	
$a > 12b$ or 100 mm when b is > 25 mm	E'	3.9×10^8	18	
7.2 Base metal subject to longitudinal stress at details attached by fillet or partial-joint-penetration groove welds, with or without transverse load on detail, when the detail embodies a transition radius, R , with weld termination ground smooth:				In weld termination ex-tending into member
$R > 50$ mm	D	22×10^8	48	
$R \leq 50$ mm	E	11×10^8	31	
<p>¹ "Attachment" as used herein, is defined as any steel detail welded to a member which, by its mere presence and independent of its loading, causes a discontinuity in the stress flow in the member and thus reduces the fatigue resistance.</p>				
SECTION 8 - MISCELLANEOUS				
8.1 Base metal at stud-type shear connectors attached by fillet or electric stud welding.	C	44×10^8	69	At toe of weld in base metal
8.2 Shear on throat of continuous or intermittent longitudinal or transverse fillet welds.	F	150×10^{10} (Eq. 6.10.277)	55	In throat of weld
8.3 Base metal at plug or slot welds.	E	11×10^8	31	At end of weld in base metal
8.4 Shear on plug or slot welds.	F	150×10^{10} (Eq. 6.10.277)	55	At faying surface

Description	Stress Category	Constant C_f	Threshold F_{TH} (MPa)	Potential Crack Initiation Point
8.5 Not fully tightened high-strength bolts, common bolts, threaded anchor rods and hanger rods with cut, ground or rolled threads. Stress range on tensile stress area due to live load plus prying action when applicable.	E'	3.9×10^8	48	At the root of the threads extending into the tensile stress area

Table 6.10.14b: Fatigue Design Parameters (Illustrated Typical Examples)

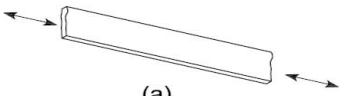

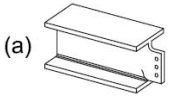
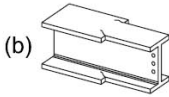
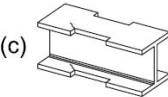
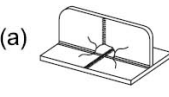
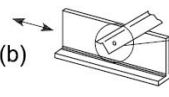
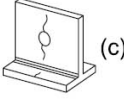
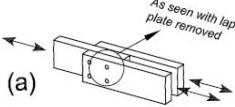
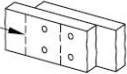

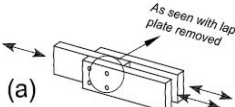
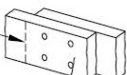

SECTION 1- PLAIN MATERIAL AWAY FROM ANY WELDING			
1.1 and 1.2			
1.3			
1.4			
SECTION 2- CONNECTED MATERIAL IN MECHANICALLY FASTENED JOINTS			
2.1			
2.2			

Table 6.10.14b: Fatigue Design Parameters (Illustrated Typical Examples)

2.3	
2.4	
<p>SECTION 3– WELDED JOINTS JOINING COMPONENTS OF BUILT-UP MEMBERS</p>	
3.1	
3.2	
3.3	
3.4	
3.5	
3.6	
<p>SECTION 4– LONGITUDINAL FILLET WELDED END CONNECTIONS</p>	
4.1	

Table 6.10.14b: Fatigue Design Parameters (Illustrated Typical Examples)

SECTION 5 – WELDED JOINTS TRANSVERSE TO DIRECTION OF STRESS	
5.1	
5.2	
5.3	
5.4	
5.5	
5.6	

Table 6.10.14b: Fatigue Design Parameters (Illustrated Typical Examples)

<p>5.7</p>	
<p>SECTION 6- BASE METAL AT WELDED TRANSVERSE MEMBER CONNECTIONS</p>	
<p>6.1</p>	
<p>6.2</p>	
<p>6.3</p>	
<p>6.4</p>	

Table 6.10.14b: Fatigue Design Parameters (Illustrated Typical Examples)

SECTION7- BASE METAL AT SHORT ATTACHMENTS1	
7.1	
7.2	
SECTION8- MISCELLANEOUS	
8.1	
8.2	
8.3	
8.4	
8.5	

10.18 Structural Design for Fire Conditions

This Section provides criteria for the design and evaluation of structural steel components, systems and frames for fire conditions. These criteria provide for the determination of the heat input, thermal expansion and degradation in mechanical properties of materials at elevated temperatures that cause progressive decrease in strength and stiffness of structural components and systems at elevated temperatures.

10.18.1 General Provisions

The methods contained in this Section provide regulatory evidence of compliance in accordance with the design applications outlined in this Section.

10.18.1.1 Performance objective

Structural components, members and building frame systems shall be designed so as to maintain their load-bearing function during the design-basis fire and to satisfy other performance requirements specified for the building occupancy. Deformation criteria shall be applied where the means of providing structural fire resistance, or the design criteria for fire barriers, requires consideration of the deformation of the load-carrying structure. Within the compartment of fire origin, forces and deformations from the design basis fire shall not cause a breach of horizontal or vertical compartmentation.

10.18.1.2 Design by engineering analysis

The analysis methods in Sec 10.18.2 are permitted to be used to document the anticipated performance of steel framing when subjected to design-basis fire scenarios. Methods in Sec 10.18.2 provide evidence of compliance with performance objectives established in Sec 10.18.1.1.

The analysis methods in Sec 10.18.2 are permitted to be used to demonstrate an equivalency for an alternative material or method, as permitted by the Code.

10.18.1.3 Design by qualification testing

The qualification testing methods in Sec 10.18.3 are permitted to be used to document the fire resistance of steel framing subject to the standardized fire testing protocols required by building Codes.

10.18.1.4 Load combinations and required strength

The required strength of the structure and its elements shall be determined from the following gravity load combination:

$$[0.9 \text{ or } 1.2]D + T + 0.5L \quad (6.10.284)$$

Where,

D = nominal dead load

L = nominal occupancy live load

T = nominal forces and deformations due to the design-basis fire defined in Section 4.2.1

A lateral notional load, $N_i = 0.002Y_i$, as defined in Sec 10.20, where N_i = notional lateral load applied at framing level i and Y_i = gravity load from combination 10.18.1.1 acting on framing level i , shall be applied in combination with the loads stipulated in Eq. 6.10.284. Unless otherwise stipulated by the Authority, D, L and S shall be the nominal loads specified in Chapter 2 of Part 6 of this Code.

10.18.2 Structural Design for Fire Conditions by Analysis

It is permitted to design structural members, components and building frames for elevated temperatures in accordance with the requirements of this Section.

10.18.2.1 Design-basis fire

A design-basis fire shall be identified to describe the heating conditions for the structure. These heating conditions shall relate to the fuel commodities and compartment characteristics present in the assumed fire area. The fuel load density based on the occupancy of the space shall be considered when determining the total fuel load. Heating conditions shall be specified either in terms of a heat flux or temperature of the upper gas layer created by the fire. The variation of the heating conditions with time shall be determined for the duration of the fire.

When the analysis methods in Sec 10.18.2 are used to demonstrate an equivalency as an alternative material or method as permitted by Code, the design-basis fire shall be determined in accordance with ASTM E119.

10.18.2.1.1 Localized fire

Where the heat release rate from the fire is insufficient to cause flashover, a localized fire exposure shall be assumed. In such cases, the fuel composition, arrangement of the fuel array and floor area occupied by the fuel shall be used to determine the radiant heat flux from the flame and smoke plume to the structure.

10.18.2.1.2 Post-flashover compartment fires

Where the heat release rate from the fire is sufficient to cause flashover, a post-flashover compartment fire shall be assumed. The determination of the temperature versus time profile resulting from the fire shall include fuel load, ventilation characteristics to the space (natural and mechanical), compartment dimensions and thermal characteristics of the compartment boundary.

10.18.2.1.3 Exterior fires

The exposure of exterior structure to flames projecting from windows or other wall openings as a result of a post-flashover compartment fire shall be considered along with the radiation from the interior fire through the opening. The shape and length of the flame projection shall be used along with the distance between the flame and the exterior steelwork to determine the heat flux to the steel. The method identified in Sec 10.18.2.1.2 shall be used for describing the characteristics of the interior compartment fire.

10.18.2.1.4 Fire duration

The fire duration in a particular area shall be determined by considering the total combustible mass, in other words, fuel load available in the space. In the case of either a localized fire or a post-flashover compartment fire, the time duration shall be determined as the total combustible mass divided by the mass loss rate, except where determined from Sec 10.18.2.1.2.

10.18.2.1.5 Active fire protection systems

The effects of active fire protection systems shall be considered when describing the design-basis fire.

Where automatic smoke and heat vents are installed in nonsprinklered spaces, the resulting smoke temperature shall be determined from calculation.

10.18.2.2 Temperatures in structural systems under fire conditions

Temperatures within structural members, components and frames due to the heating conditions posed by the design-basis fire shall be determined by a heat transfer analysis.

10.18.2.3 Material strengths at elevated temperatures

Material properties at elevated temperatures shall be determined from test data. In the absence of such data, it is permitted to use the material properties stipulated in this Section. These relationships do not apply for steels with a yield strength in excess of 448 MPa or concretes with specified compression strength in excess of 55 MPa.

Table 6.10.15: Properties of Steel at Elevated Temperatures

Steel Temperature °C	$k_E = E_m/E$	$k_y = F_{ym}/F_y$	$k_u = F_{um}/F_y$
20	*	*	*
93	1.00	*	*
204	0.90	*	*

Steel Temperature °C	$k_E = E_m/E$	$k_y = F_{ym}/F_y$	$k_u = F_{um}/F_y$
316	0.78	*	*
399	0.70	1.00	1.00
427	0.67	0.94	0.94
538	0.49	0.66	0.66
649	0.22	0.35	0.35
760	0.11	0.16	0.16
871	0.07	0.07	0.07
982	0.05	0.04	0.04
1093	0.02	0.02	0.02
1204	0.00	0.00	0.00
*Use Ambient Properties			

10.18.2.3.1 Thermal elongation

Thermal expansion of structural and reinforcing steels: For calculations at temperatures above 65°C, the coefficient of thermal expansion shall be 1.4×10^{-5} per °C.

Thermal expansion of normal weight concrete: For calculations at temperatures above 65 °C, the coefficient of thermal expansion shall be 1.8×10^{-5} per °C.

Thermal expansion of lightweight concrete: For calculations at temperatures above 65°C, the coefficient of thermal expansion shall be 7.9×10^{-6} per °C.

10.18.2.3.2 Mechanical properties at elevated temperatures

The deterioration in strength and stiffness of structural members, components, and systems shall be taken into account in the structural analysis of the frame.

The values F_{ym} , F_{um} , E_m , f'_{cm} , E_{cm} and ϵ_{cu} at elevated temperature to be used in structural analysis, expressed as the ratio with respect to the property at ambient, assumed to be 20° C, shall be defined as in Tables 6.10.15 and 6.10.16. It is permitted to interpolate between these values.

10.18.2.4 Structural design requirements

10.18.2.4.1 General structural integrity

The structural frame shall be capable of providing adequate strength and deformation capacity to withstand, as a system, the structural actions developed during the fire within the prescribed limits of deformation. The structural system shall be designed to sustain local damage with structural system as a whole remaining stable.

Continuous load paths shall be provided to transfer all forces from the exposed region to the final point of resistance. The foundation shall be designed to resist the forces and to accommodate the deformations developed during the design-basis fire.

Table 6.10.16: Properties of Concrete at Elevated Temperatures

Concrete Temperature °C	$k_c = f'_{cm}/f'_c$		E_{am}/E_c	ϵ_{cu} (%)
	NWC	LWC		LWC
20	1.00	1.00	1.00	0.25
93	0.95	1.00	0.93	0.34
204	0.90	1.00	0.75	0.46
288	0.86	1.00	0.61	0.58
316	0.83	0.98	0.57	0.62
427	0.71	0.85	0.38	0.80
538	0.54	0.71	0.20	1.06
649	0.38	0.58	0.092	1.32
760	0.21	0.45	0.073	1.43
871	0.10	0.31	0.055	1.49
982	0.05	0.18	0.036	1.50
1093	0.01	0.05	0.018	1.50
1204	0.00	0.00	0.00	-

10.18.2.4.2 Strength requirements and deformation limits

Conformance of the structural system to these requirements shall be demonstrated by constructing a mathematical model of the structure based on principles of structural mechanics and evaluating this model for the internal forces and deformations in the members of the structure developed by the temperatures from the design-basis fire.

Individual members shall be provided with adequate strength to resist the shears, axial forces and moments determined in accordance with these provisions.

Connections shall develop the strength of the connected members or the forces indicated above. Where the means of providing fire resistance requires the consideration of deformation criteria, the deformation of the structural system, or members thereof, under the design-basis fire shall not exceed the prescribed limits.

10.18.2.4.3 Methods of analysis

(a) Advanced methods of analysis

The methods of analysis in this Section are permitted for the design of all steel building structures for fire conditions. The design-basis fire exposure shall be that determined in Sec 10.18.2.1. The analysis shall include both a thermal response and the mechanical response to the design-basis fire.

The thermal response shall produce a temperature field in each structural element as a result of the design-basis fire and shall incorporate temperature- dependent thermal properties of the structural elements and fire-resistive materials as per Sec 10.18.2.2.

The mechanical response results in forces and deflections in the structural system subjected to the thermal response calculated from the design-basis fire. The mechanical response shall take into account explicitly the deterioration in strength and stiffness with increasing temperature, the effects of thermal expansions and large deformations. Boundary conditions and connection fixity must represent the proposed structural design. Material properties shall be defined as per Sec 10.18.2.3.

The resulting analysis shall consider all relevant limit states, such as excessive deflections, connection fractures, and overall or local buckling.

(b) Simple Methods of Analysis

The methods of analysis in this Section are applicable for the evaluation of the performance of individual members at elevated temperatures during exposure to fire. The support and restraint conditions (forces, moments and boundary conditions) applicable at normal temperatures may be assumed to remain unchanged throughout the fire exposure.

(1) Tension members

It is permitted to model the thermal response of a tension element using a one-dimensional heat transfer equation with heat input as directed by the design-basis fire defined in Sec 10.18.2.1.

The design strength of a tension member shall be determined using the provisions of Sec 10.4, with steel properties as stipulated in Sec 10.18.2.3 and assuming a uniform temperature over the cross section using the temperature equal to the maximum steel temperature.

(2) Compression members

It is permitted to model the thermal response of a compression element using a one-dimensional heat transfer equation with heat input as directed by the design-basis fire defined in Sec 10.18.2.1.

The design strength of a compression member shall be determined using the provisions of Sec 10.5 with steel properties as stipulated in Sec 10.18.2.3.

(3) Flexural members

It is permitted to model the thermal response of flexural elements using a one-dimensional heat transfer equation to calculate bottom flange temperature and to assume that this bottom flange temperature is constant over the depth of the member. The design strength of a flexural member shall be determined using the provisions of Sec 10.6 with steel properties as stipulated in Sec 10.18.2.3.

(4) Composite floor members

It is permitted to model the thermal response of flexural elements supporting a concrete slab using a one-dimensional heat transfer equation to calculate bottom flange temperature. That temperature shall be taken as constant between the bottom flange and mid-depth of the web and shall decrease linearly by no more than 25 percent from the mid-depth of the web to the top flange of the beam.

The design strength of a composite flexural member shall be determined using the provisions of Chapter 13 Part 6 of this Code, with reduced yield stresses in the steel consistent with the temperature variation described under thermal response.

10.18.2.4.4 Design strength

The design strength shall be determined as in Sec 10.2.3.3. The nominal strength, R_n shall be calculated using material properties, as stipulated in Sec 10.18.2.3, at the temperature developed by the design-basis fire.

10.18.3 Design by Qualification Testing

10.18.3.1 Design strength

Structural members and components in steel buildings shall be qualified for the rating period in conformance with ASTM E119. It shall be permitted to demonstrate compliance with these requirements using the procedures specified for steel construction in Section 5 of ASCE/SFPE 29.

10.18.3.2 Restrained construction

For floor and roof assemblies and individual beams in buildings, a restrained condition exists when the surrounding or supporting structure is capable of resisting actions caused by thermal expansion throughout the range of anticipated elevated temperatures.

Steel beams, girders and frames supporting concrete slabs that are welded or bolted to integral framing members (in other words, columns, girders) shall be considered restrained construction.

10.18.3.3 Unrestrained construction

Steel beams, girders and frames that do not support a concrete slab shall be considered unrestrained unless the members are bolted or welded to surrounding construction that has been specifically designed and detailed to resist actions caused by thermal expansion.

A steel member bearing on a wall in a single span or at the end span of multiple spans shall be considered unrestrained unless the wall has been designed and detailed to resist effects of thermal expansion.

10.19 Stability Bracing for Columns and Beams

This Section addresses the minimum brace strength and stiffness necessary to provide member strengths based on the unbraced length between braces with an effective length factor, K , equal to 1.0.

10.19.1 General Provisions

Bracing is assumed to be perpendicular to the members to be braced; for inclined or diagonal bracing, the brace strength (force or moment) and stiffness (force per unit displacement or moment per unit rotation) shall be adjusted for the angle of inclination. The evaluation of the stiffness furnished by a brace shall include its member and geometric properties, as well as the effects of connections and anchoring details.

Two general types of bracing systems are considered, relative and nodal. A relative brace controls the movement of the brace point with respect to adjacent braced points. A nodal brace controls the movement at the braced point without direct interaction with adjacent braced points. The available strength and stiffness of the bracing shall equal or exceed the required limits unless analysis indicates that smaller values are justified by analysis.

A second-order analysis that includes an initial out-of-straightness of the member to obtain brace strength and stiffness is permitted in lieu of the requirements of this Section.

10.19.2 Columns

It is permitted to brace an individual column at end and intermediate points along its length by either relative or nodal bracing systems. It is assumed that nodal braces are equally spaced along the column.

10.19.2.1 Relative bracing

The required brace strength is

$$P_{br} = 0.004 P_r \quad (6.10.285)$$

The required brace stiffness is

$$\beta_{br} = \frac{1}{\phi} \left(\frac{2P_r}{L_b} \right) \text{ (LRFD)} \quad \beta_{br} = \Omega \left(\frac{2P_r}{L_b} \right) \text{ (ASD)} \quad (6.10.286)$$

Where,

$$\phi = 0.75 \text{ (LRFD)} \quad \Omega = 2.00 \text{ (ASD)}$$

For design according to Sec 10.2.3.3 (LRFD)

P_r = required axial compressive strength using LRFD load combinations, N

For design according to Sec 10.2.3.4 (ASD)

P_r = required axial compressive strength using ASD load combinations, N

10.19.2.2 Nodal bracing

The required brace strength is

$$P_{br} = 0.01 P_r \quad (6.10.287)$$

The required brace stiffness is

$$\beta_{br} = \frac{1}{\phi} \left(\frac{8P_r}{L_b} \right) \text{ (LRFD)} \quad \beta_{br} = \Omega \left(\frac{8P_r}{L_b} \right) \text{ (ASD)} \quad (6.10.288)$$

Where, $\phi = 0.75$ (LRFD) $\Omega = 2.00$ (ASD)

For design according to Sec 10.2.3.3 (LRFD)

P_r = required axial compressive strength using LRFD load combinations, N

For design according to Sec 10.2.3.4 (ASD)

P_r = required axial compressive strength using ASD load combinations, N

When, L_b is less than L_q , where L_q is the maximum unbraced length for the required column force with K equal to 1.0, then L_b in Eq. 6.10.288 is permitted to be taken equal to L_q .

10.19.3 Beams

At points of support for beams, girders and trusses, restraint against rotation about their longitudinal axis shall be provided. Beam bracing shall prevent the relative displacement of the top and bottom flanges, in other words, twist of the section. Lateral stability of beams shall be provided by lateral bracing, torsional bracing or a combination of the two. In members subjected to double curvature bending, the inflection point shall not be considered a brace point.

10.19.3.1 Lateral bracing

Bracing shall be attached near the compression flange, except for a cantilevered member, where an end brace shall be attached near the top (tension) flange. Lateral bracing shall be attached to both flanges at the brace point nearest the inflection point for beams subjected to double curvature bending along the length to be braced.

(a) Relative bracing

The required brace strength is

$$P_{br} = 0.008 M_r C_d / h_o \quad (6.10.289)$$

The required brace stiffness is

$$\beta_{br} = \frac{1}{\phi} \left(\frac{4M_r C_d}{L_b h_o} \right) \text{ (LRFD)} \quad \beta_{br} = \Omega \left(\frac{4M_r C_d}{L_b h_o} \right) \text{ (ASD)} \quad (6.10.290)$$

Where, $\phi = 0.75$ (LRFD) $\Omega = 2.00$ (ASD)

h_o = distance between flange centroids, mm.

$C_d = 1.0$ for bending in single curvature; 2.0 for double curvature; $C_d = 2.0$ only applies to the brace closest to the inflection point.

L_b = laterally unbraced length, mm.

For design according to Section 10.2.3.3 (LRFD):

M_r = required flexural strength using LRFD load combinations, N-mm

For design according to Section 10.2.3.4 (ASD):

M_r = required flexural strength using ASD load combinations, N-mm

(b) Nodal bracing

The required brace strength is

$$P_{br} = 0.02 M_r C_d / h_o \quad (6.10.291)$$

The required brace stiffness is

$$\beta_{br} = \frac{1}{\phi} \left(\frac{10 M_r C_d}{L_b h_o} \right) \text{ (LRFD)} \quad \beta_{br} = \Omega \left(\frac{10 M_r C_d}{L_b h_o} \right) \text{ (ASD)} \quad (6.10.292)$$

Where, $\phi = 0.75$ (LRFD) $\Omega = 2.00$ (ASD)

For design according to Section 10.2.3.3 (LRFD):

M_r = required flexural strength using LRFD load combinations, N-mm

For design according to Section 10.2.3.4 (ASD):

M_r = required flexural strength using ASD load combinations, N-mm

When L_b is less than L_q , the maximum unbraced length for M_r , then L_b in Eq. 6.10.292 shall be permitted to be taken equal to L_q .

10.19.3.2 Torsional bracing

It is permitted to provide either nodal or continuous torsional bracing along the beam length. It is permitted to attach the bracing at any cross-sectional location and it need not be attached near the compression flange. The connection between a torsional brace and the beam shall be able to support the required moment given below.

(a) Nodal bracing

The required bracing moment is

$$M_{br} = \frac{0.024 M_r L}{n C_b L_b} \quad (6.10.293)$$

The required cross-frame or diaphragm bracing stiffness is

$$\beta_{Tb} = \frac{\beta_T}{\left(1 - \frac{\beta_T}{\beta_{sec}}\right)} \quad (6.10.294)$$

Where,

$$\beta_T = \frac{1}{\phi} \left(\frac{2.4LM_r^2}{nEI_y C_b^2} \right) \text{ (LRFD)}$$

$$\beta_T = \Omega \left(\frac{2.4LM_r^2}{nEI_y C_b^2} \right) \text{ (ASD)} \quad (6.10.295)$$

$$\beta_{sec} = \frac{3.3 E}{h_o} \left(\frac{1.5h_o t_w^3}{12} + \frac{t_s b_s^3}{12} \right) \quad (6.10.296)$$

Where, $\phi = 0.75$ (LRFD) $\Omega = 3.00$ (ASD)

L = span length, mm

n = number of nodal braced points within the span

E = modulus of elasticity of steel 200000 MPa

I_y = out-of-plane moment of inertia, mm⁴

C_b = modification factor defined in Sec 10.6

t_w = beam web thickness, mm

t_s = web stiffener thickness, mm

b_s = stiffener width for one-sided stiffeners (use twice the individual stiffener width for pairs of stiffeners), mm.

β_T = brace stiffness excluding web distortion, N-mm/radian

β_{sec} = web distortional stiffness, including the effect of web transverse stiffeners, if any, N-mm/radian

For design according to Sec 10.2.3.3 (LRFD)

M_r = required flexural strength using LRFD load combinations, N-mm

For design according to Sec 10.2.3.4 (ASD)

M_r = required flexural strength using ASD load combinations, N-mm

If $\beta_{sec} < \beta_T$, Eq. 6.10.294 is negative, which indicates that torsional beam bracing will not be effective due to inadequate web distortional stiffness.

When required, the web stiffener shall extend the full depth of the braced member and shall be attached to the flange if the torsional brace is also attached to the flange. Alternatively, it shall be permissible to stop the stiffener short by a distance equal to $4t_w$ from any beam flange that is not directly attached to the torsional brace. When L_b is less than L_q then L_b in Eq. 6.10.293 shall be permitted to be taken equal to L_q .

(b) Continuous torsional bracing

For continuous bracing, use Equations 6.10.293, 6.10.294 and 6.10.296 with L/n taken as 1.0 and L_b taken as L_q ; bracing moment and stiffness are given per unit span length. The distortional stiffness for an unstiffened web is

$$\beta_{sec} = \frac{3.3 Et_w^3}{12h_o} \quad (6.10.297)$$

10.19.4 Slenderness Limitations

The slenderness ratio, L/r , of any stability bracing shall not exceed 180 unless a comprehensive analysis including second order effects justifies a higher value.

10.20 Seismic Provisions for Structural Steel Buildings

10.20.1 Scope

The Seismic Provisions for Structural Steel Buildings, hereinafter referred to as these Provisions as outline in this Sec 10.20, shall govern the design, fabrication and erection of structural steel members and connections in the seismic load resisting systems (SLRS) and splices in columns that are not part of the SLRS, in buildings and other structures, where other structures are defined as those structures designed, fabricated and erected in a manner similar to buildings, with building-like vertical and lateral load-resisting-elements.

These Provisions shall apply when the seismic response modification coefficient, R , (as specified in Chapter 2 of Part 6) is taken greater than 3, regardless of the seismic design category. When the seismic response modification coefficient, R , is taken as 3 or less, the structure is not required to satisfy the Provisions this Sec 10.20, unless specifically required by the applicable authority.

These Provisions shall be applied in conjunction with the specification set forth in Sections 10.1 to 10.19 whichever is applicable.

Loads, load combinations, system limitations and general design requirements shall be those in Chapter 2 Part 6 of this Code as well as those mentioned in Sec 10.2.

10.20.2 Referenced Specifications, Codes and Standards

The documents referenced in these Provisions shall include those listed in Sec 10.1.2 with the following additions and modifications:

American Institute of Steel Construction (AISC):

- Specification for Structural Steel Buildings, ANSI/AISC 360-05
- Prequalified Connections for Special and Intermediate Steel Moment Frames for Seismic Applications, ANSI/AISC 358-05

American Society for Nondestructive Testing (ASNT):

- Recommended Practice for the Training and Testing of Nondestructive Testing Personnel, ASNT SNT TC-1a-2001
- Standard for the Qualification and Certification of Nondestructive Testing Personnel, ANSI/ASNT CP-189-2001

American Welding Society (AWS):

- Standard Methods for Determination of the Diffusible Hydrogen Content of Martensitic, Bainitic, and Ferritic Steel Weld Metal Produced by Arc Welding, AWS A4.3-93R
- Standard Methods for Mechanical Testing of Welds-U.S. Customary, ANSI/AWS B4.0-98
- Standard Methods for Mechanical Testing of Welds–Metric Only, ANSI/AWS B4.0M:2000
- Standard for the Qualification of Welding Inspectors, AWS B5.1:2003
- Oxygen Cutting Surface Roughness Gauge and Wall Chart for Criteria Describing Oxygen-Cut Surfaces, AWS C4.1

Federal Emergency Management Agency (FEMA)

- Recommended Seismic Design Criteria for New Steel Moment-Frame Buildings, FEMA 350, July 2000

10.20.3 General Seismic Design Requirements

The required strength and other seismic provisions and the limitations on height and irregularity are specified in Chapter 2 Part 6 of this Code.

The design story drift shall be in accordance with the requirements set forth in Chapter 2 Part 6 of this Code.

10.20.4 Loads, Load Combinations, and Nominal Strengths**10.20.4.1 Loads and load combinations**

The loads and load combinations shall be as stipulated in Chapter 2 Part 6 of this Code. Where amplified seismic loads are required by these Provisions, the horizontal portion of the earthquake load E (as defined in Chapter 2 Part 6) shall be multiplied by the system over strength factor, Ω_o . The magnitude of over strength factor shall generally be obtained from Table 6.2.19 of Chapter 2 Part 6 of this Code. Reference may be made to Table 12.2-1 of ASCE 7-05 if data for a particular structure type is not found in Table 6.2.19. The value of Ω_o for a structural system shall be taken as 2.0 if it is not specified elsewhere.

10.20.4.2 Nominal strength

The nominal strength of systems, members and connections shall comply with the Specification, except as modified throughout these Provisions.

10.20.5 Structural Design Drawings and Specifications, Shop Drawings, and Erection Drawings**10.20.5.1 Structural design drawings and specifications**

Structural design drawings and specifications shall show the work to be performed, and include items required by the Specification and the following, as applicable:

- (1) Designation of the seismic load resisting system (SLRS)
- (2) Designation of the members and connections that are part of the SLRS
- (3) Configuration of the connections
- (4) Connection material specifications and sizes
- (5) Locations of demand critical welds
- (6) Lowest Anticipated Service Temperature (LAST) of the steel structure, if the structure is not enclosed and maintained at a temperature of 10° C or higher.
- (7) Locations and dimensions of protected zones
- (8) Locations where gusset plates are to be detailed to accommodate inelastic rotation
- (9) Welding requirements as specified in Appendix S, Sec S.2.1.

10.20.5.2 Shop drawings

Shop drawings shall include items required by the Specification and the following, as applicable:

- (1) Designation of the members and connections that are part of the SLRS
- (2) Connection material specifications
- (3) Locations of demand critical shop welds
- (4) Locations and dimensions of protected zones
- (5) Gusset plates drawn to scale when they are detailed to accommodate inelastic rotation
- (6) Welding requirements as specified in Appendix S, Sec S.2.2.

10.20.5.3 Erection drawings

Erection drawings shall include items required by the Specification and the following, as applicable:

- (1) Designation of the members and connections that are part of the SLRS
- (2) Field connection material specifications and sizes
- (3) Locations of demand critical field welds
- (4) Locations and dimensions of protected zones
- (5) Locations of pretensioned bolts
- (6) Field welding requirements as specified in Appendix S, Sec S.2.3

10.20.6 Materials

10.20.6.1 Material specifications

Structural steel used in the seismic load resisting system (SLRS) shall meet the requirements of Sec 10.1.3.1a, except as modified in present Sec 10.20. The specified minimum yield stress of steel to be used for members in which inelastic behavior is expected shall not exceed 345 MPa for systems defined in Sections 10.20.9, 10.20.10, 10.20.12, 10.20.13, 10.20.15, 10.20.16, and 10.20.17 nor 380 MPa for systems defined in Sections 10.20.11 and 10.20.14, unless the suitability of the material is determined by testing or other rational criteria. This limitation does not apply to columns for which only expected inelastic behavior is yielding at column base.

The structural steel used in the SLRS described in Sections 10.20.9 to 10.20.17 shall meet one of the following ASTM Specifications: A36/ A36M, A53/A53M, A500 (Grade B or C), A501, A529/A529M, A572/A572M [Grade 290, 345 or 380], A588/A588M, A913/A913M [Grade 345, 415 or 450], A992/A992M, or A1011 HSLAS Grade 380. The structural steel used for column base plates shall meet one of the preceding ASTM specifications or ASTM A283/A283M Grade D.

Other steels and non-steel materials in buckling-restrained braced frames are permitted to be used subject to the requirements of Sec 10.20.16 and Appendix R.

10.20.6.2 Material properties for determination of required strength of members and connections

The required strength of an element (a member or a connection) shall be determined from the expected yield stress, $R_y F_y$, of an adjoining member, where F_y is the specified minimum yield stress of the grade of steel to be used in the adjoining members and R_y is the ratio of the expected yield stress to the specified minimum yield stress, F_y , of that material.

The available strength of the element, ϕR_n for LRFD and R_n/Ω for ASD, shall be equal to or greater than the required strength, where R_n is the nominal strength of the connection. The expected tensile strength, $R_t F_u$, and the expected yield stress, $R_y F_y$, are permitted to be used in lieu of F_u and F_y , respectively, in determining the nominal strength, R_n , of rupture and yielding limit states within the same member for which the required strength is determined.

The values of R_y and R_t for various steels are given in Table 6.10.17. Other values of R_y and R_t shall be permitted if the values are determined by testing of specimens similar in size and source conducted in accordance with the requirements for the specified grade of steel.

10.20.6.3 Heavy section CVN requirements

For structural steel in the SLRS, in addition to the requirements of Sec 10.1.3.1c, hot rolled shapes with flange thickness 38 mm and thicker shall have a minimum Charpy V-Notch toughness of 27 J at 21°C, tested in the alternate core location as described in ASTM A6 Supplementary Requirement S30. Plates 50 mm thick and thicker shall have a minimum Charpy V-Notch toughness of 27 J at 21°C, measured at any location permitted by ASTM A673, where the plate is used in the following:

- (1) Members built-up from plate
- (2) Connection plates where inelastic strain under seismic loading is expected
- (3) As the steel core of buckling-restrained braces.

10.20.7 Connections, Joints and Fasteners

10.20.7.1 *Scope*

Connections, joints and fasteners that are part of the Seismic Load Resisting System (SLRS) shall comply with Sec 10.10, and with the additional requirements of this Section.

The design of connections for a member that is a part of the SLRS shall be configured such that a ductile limit state in either the connection or the member controls the design.

10.20.7.2 Bolted joints

All bolts shall be pre-tensioned high strength bolts and shall meet the requirements for slip-critical faying surfaces in accordance with Sec 10.10.3.8 with a Class A surface. Bolts shall be installed in standard holes or in short-slotted holes perpendicular to the applied load. For brace diagonals, oversized holes shall be permitted when the connection is designed as a slip-critical joint, and the oversized hole is in one ply only. Alternative hole types are permitted if determined in a connection prequalification in accordance with Appendix N, or if determined in a program of qualification testing in accordance with Appendix Q or R. The available shear strength of bolted joints using standard holes shall be calculated as that for bearing-type joints in accordance with Sections 10.10.3.7 and 10.10.3.10, except that the nominal bearing strength at bolt holes shall not be taken greater than $2.4dtF_u$.

Exception: The faying surfaces for end plate moment connections are permitted to be coated with coatings not tested for slip resistance, or with coatings with a slip coefficient less than that of a Class A faying surface.

Bolts and welds shall not be designed to share force in a joint or the same force component in a connection.

Table 6.10.17: R_y and R_t Values for Different Member Types

Application	R_y	R_t
Hot-rolled structural shapes and bars:		
• ASTM A36/A36M	1.5	1.2
• ASTM A572/572M Grade 42 (290)	1.3	1.1
• ASTM A572/572M Grade 50 (345) or 55 (380), ASTM A913/A913M Grade 50 (345), 60 (415), or 65 (450), ASTM A588/A588M, ASTM A992/A992M, A1011 HSLAS Grade 55 (380)	1.1	1.1

Application	R_y	R_t
• ASTM A529 Grade 50 (345)	1.2	1.2
• ASTM A529 Grade 55 (380)	1.1	1.2
Hollow structural sections (HSS):		
• ASTM A500 (Grade B or C), ASTM A501	1.4	1.3
Pipe:		
• ASTM A53/A53M	1.6	1.2
Plates:		
• ASTM A36/A36M	1.3	1.2
• ASTM A572/A572M Grade 50 (345), ASTM A588/A588M	1.1	1.2

10.20.7.3 Welded Joints

Welding shall be performed in accordance with Appendix S. Welding shall be performed in accordance with a welding procedure specification (WPS) as required in AWS D1.1. The WPS variables shall be within the parameters established by the filler metal manufacturer.

10.20.7.3.1 General requirements

All welds used in members and connections in the SLRS shall be made with a filler metal that can produce welds that have a minimum Charpy V-Notch toughness of 27 J at minus 18°C, as determined by the appropriate AWS A5 classification test method or manufacturer certification. This requirement for notch toughness shall also apply in other cases as required in these Provisions.

10.20.7.3.2 Demand critical welds

Where welds are designated as demand critical, they shall be made with a filler metal capable of providing a minimum Charpy V-Notch (CVN) toughness of 27 J at 29°C as determined by the appropriate AWS classification test method or manufacturer certification, and 54 J at 21°C as determined by Appendix T or other approved method, when the steel frame is normally enclosed and maintained at a temperature of 10°C or higher. For structures with service temperatures lower than 10°C, the qualification temperature for Appendix T shall be 11°C above the lowest anticipated service temperature, or at a lower temperature.

SMAW electrodes classified in AWS A5.1 as E7018 or E7018-X, SMAW electrodes classified in AWS A5.5 as E7018-C3L or E8018-C3, and GMAW solid electrodes are exempted from production lot testing when the CVN toughness of the electrode equals or exceeds 27 J at a temperature not exceeding 29°C as determined by AWS classification test methods. The manufacturer's certificate of compliance shall be considered sufficient evidence of meeting this requirement.

10.20.7.3.3 Protected zone

Where a protected zone is designated by these Provisions, it shall comply with the following:

- (1) Within the protected zone, discontinuities created by fabrication or erection operations, such as tack welds, erection aids, air-arc gouging and thermal cutting shall be repaired as required by the engineer of record.
- (2) Welded shear studs and decking attachments that penetrate the beam flange shall not be placed on beam flanges within the protected zone. Decking arc spot welds as required to secure decking shall be permitted.
- (3) Welded, bolted, screwed or shot-in attachments for perimeter edge angles, exterior facades, partitions, duct work, piping or other construction shall not be placed within the protected zone.

Exception:

Welded shear studs and other connections shall be permitted when determined in accordance with a connection prequalification in accordance with Appendix N, or as determined in a program of qualification testing in accordance with Appendix Q.

Outside the protected zone, calculations based upon the expected moment shall be made to demonstrate the adequacy of the member net section when connectors that penetrate the member are used.

10.20.7.3.4 Continuity plates and stiffeners

Corners of continuity plates and stiffeners placed in the webs of rolled shapes shall be clipped as described below. Along the web, the clip shall be detailed so that the clip extends a distance of at least 38 mm beyond the published k detail dimension for the rolled shape. Along the flange, the clip shall be detailed so that the clip does not exceed a distance of 12 mm beyond the published k_1 detail dimension. The clip shall be detailed to facilitate suitable weld terminations for both the flange weld and the web weld. If a curved clip is used, it shall have a minimum radius of 12 mm.

At the end of the weld adjacent to the column web/flange juncture, weld tabs for continuity plates shall not be used, except when permitted by the engineer of record. Unless specified by the engineer of record that they be removed, weld tabs shall not be removed when used in this location.

10.20.8 Members

10.20.8.1 Scope

Members in the seismic load resisting system (SLRS) shall comply with the specifications of Sections 10.1 to 10.11 and Sec 10.20.8. For columns that are not part of the SLRS, see Sec 10.20.8.4.2.

10.20.8.2 Classification of sections for local buckling

10.20.8.2.1 Compact

When required by these Provisions, members of the SLRS shall have flanges continuously connected to the web or webs and the width-thickness ratios of its compression elements shall not exceed the limiting width-thickness ratios, λ_p , from Specification Table 6.10.1.

10.20.8.2.2 Seismically compact

When required by these Provisions, members of the SLRS must have flanges continuously connected to the web or webs and the width-thickness ratios of its compression elements shall not exceed the limiting width-thickness ratios, λ_{ps} , from Provisions Table 6.10.1.

10.20.8.3 Column strength

When $\frac{P_u}{\phi_c P_n}$ (LRFD) > 0.4 or $\frac{\Omega_c P_a}{P_n}$ (ASD) > 0.4, as appropriate, without consideration of amplified seismic load,

Where,

$$\phi_c = 0.90 \text{ (LRFD)} \quad \Omega_c = 1.67 \text{ (ASD)}$$

P_a = required axial strength of a column using ASD load combinations, N

P_n = nominal axial strength of a column, N

P_u = required axial strength of a column using LRFD load combinations, N

The following requirements shall be met:

- (1) The required axial compressive and tensile strength, considered in the absence of any applied moment, shall be determined using load combinations stipulated by the Code including amplified seismic load.
- (2) The required axial compressive and tensile strength shall not exceed either of the following:
 - (a) The maximum load transferred to the column considering $1.1R_y$ (LRFD) or $\left(\frac{1.1}{1.5}\right)R_y$ (ASD), as appropriate, times the nominal strengths of the connecting beam or brace elements of the building.
 - (b) The limit as determined from the resistance of the foundation to over-turning uplift.

10.20.8.4 Column splices

10.20.8.4.1 General

The required strength of column splices in the seismic load resisting system (SLRS) shall equal the required strength of the columns, including that determined from Sections 10.20.8.3, 10.20.9.9, 10.20.10.9, 10.20.11.9, 10.20.13.5 and 10.20.16.5.2.

In addition, welded column splices that are subject to a calculated net tensile load effect determined using the load combinations stipulated by the Code including the amplified seismic load, shall satisfy both of the following requirements:

- (1) The available strength of partial-joint-penetration (PJP) groove welded joints, if used, shall be at least equal to 200 percent of the required strength.
- (2) The available strength for each flange splice shall be at least equal to $0.5R_yF_yA_f$ (LRFD) or $(0.5/1.5)R_yF_yA_f$ (ASD), as appropriate, where R_yF_y is the expected yield stress of the column material and A_f is the flange area of the smaller column connected.

Beveled transitions are not required when changes in thickness and width of flanges and webs occur in column splices where PJP groove welded joints are used.

Column web splices shall be either bolted or welded, or welded to one column and bolted to the other. In moment frames using bolted splices, plates or channels shall be used on both sides of the column web.

The centerline of column splices made with fillet welds or partial-joint-penetration groove welds shall be located 1.2 m or more away from the beam-to-column connections. When the column clear height between beam-to-column connections is less than 2.4 m, splices shall be at half the clear height.

10.20.8.4.2 Columns not part of the seismic load resisting system

Splices of columns that are not a part of the SLRS shall satisfy the following:

- (1) The splices shall be located 1.2 m or more away from the beam-to-column connections. When the column clear height between beam-to-column connections is less than 2.4 m, splices shall be at half the clear height.
- (2) The required shear strength of column splices with respect to both orthogonal axes of the column shall be M_{pc}/H (LRFD) or $M_{pc}/(1.5H)$ (ASD), as appropriate, where M_{pc} is the lesser nominal plastic flexural strength of the column sections for the direction in question, and H is the story height.

10.20.8.5 Column bases

The required strength of column bases shall be calculated in accordance with Sections 10.20.8.5.1, 10.20.8.5.2, and 10.20.8.5.3. The available strength of anchor rods shall be determined in accordance with Specification Sec 10.10.3.

The available strength of concrete elements at the column base, including anchor rod embedment and reinforcing steel, shall be in accordance with Appendix D Chapter 6 Part 6 of this Code.

Exception:

The special requirements in Appendix D Chapter 6 Part 6, for “regions of moderate or high seismic risk, or for structures assigned to intermediate or high seismic performance or design categories” need not be applied.

Table 6.10.18: Limiting Width-Thickness Ratios for Compression Elements

	Description of Element	Width-Thickness Ratio	Limiting Width-Thickness Ratios
			λ_{ps} (Seismically Compact)
Unstiffened Elements	Flexure in flanges of rolled or built-up I-shaped sections ^{[a], [c], [e], [g], [h]}	b/t	$0.30\sqrt{(E/F_y)}$
	Uniform compression in flanges of rolled or built-up I-shaped sections ^{[b], [h]}	b/t	$0.30\sqrt{(E/F_y)}$
	Uniform compression in flanges of rolled or built-up I-shaped sections ^[d]	b/t	$0.38\sqrt{(E/F_y)}$

	Description of Element	Width-Thickness Ratio	Limiting Width-Thickness Ratios
			λ_{ps} (Seismically Compact)
Unstiffened Elements	Uniform compression in flanges of channels, outstanding legs of pairs of angles in continuous contact, and braces ^[c] , ^[g]	b/t	$0.30\sqrt{(E/F_y)}$
	Uniform compression in flanges of H-pile sections	b/t	$0.45\sqrt{(E/F_y)}$
	Flat bars ^[f]	b/t	2.5
	Uniform compression in legs of single angles, legs of double angle members with separators, or flanges of tees ^[g]	b/t	$0.30\sqrt{(E/F_y)}$
	Uniform compression in stems of tees ^[g]	b/t	$0.30\sqrt{(E/F_y)}$
Stiffened Elements	Webs in flexural compression in beams in SMF, Sec 10.20.9, unless noted otherwise	h/t_w	$2.45\sqrt{(E/F_y)}$
	Webs in flexural compression or combined flexure and axial compression ^[a] , ^[c] , ^[g] , ^[h] , ^[i] , ^[j]	h/t_w	For $C_a > 0.125$ [k] $3.14\sqrt{(E/F_y)}(1 - 1.54C_a)$ For $C_a \leq 0.125$ [k] $1.12\sqrt{(E/F_y)}(2.33 - C_a)$ $\geq 1.49\sqrt{E/F_y}$
	Round HSS in axial and/or flexural compression ^[c] , ^[g]	D/t	$0.044\sqrt{(E/F_y)}$
	Rectangular HSS in axial and/or flexural compression ^[c] , ^[g]	b/t or h/t_w	$0.64\sqrt{(E/F_y)}$
	Webs of H-Pile sections	h/t_w	$0.94\sqrt{(E/F_y)}$

Notes:

- [a] Required of beams in SMF, Sec 10.20.9 and SPSW, Sec 10.20.17
- [b] Required of columns in SMF, Sec 10.20.9, unless the ratios from Eq. 6.10.300 are greater than 2.0 where it is permitted to use λ_p in Specification Table 6.10.1
- [c] Required for braces and columns in SCBF, Sec 10.20.13 and braces in OCBF, Sec 10.20.14
- [d] it is permitted to use λ_p in Specification Table 6.10.1 for columns in STMF, Sec 10.20.12 and columns in EBF, Sec 10.20.15
- [e] Required for link in EBF, Sec 10.20.15, except it is permitted to use λ_p in Table 6.10.1 of the Specification for flanges of links of length $1.6 M_p/V_p$ or less, where M_p and V_p are defined in Sec 10.20.15
- [f] Diagonal web members within the special segment of STMF, Sec 10.20.12
- [g] Chord members of STMF, Sec 10.20.12
- [h] Required for beams and columns in BRBF, Sec 10.20.16
- [i] Required for columns in SPSW, Sec 10.20.17
- [j] For columns in STMF, Sec 10.20.15; or EBF webs of links of length $1.6 M_p/V_p$ or less, it is permitted to use following for λ_p
- For $C_a \leq 0.125$, $\lambda_p = 3.76 \sqrt{E/F_y} (1 - 275C_a)$
- For $C_a > 0.125$, $\lambda_p = 1.12 \sqrt{E/F_y} (2.33 - C_a) \geq 1.49 \sqrt{E/F_y}$
- [k] For LFRD, $C_a = P_u/\phi_b P_y$; For ASD, $C_a = \Omega_b P_a/P_y$

Where,

P_a = required compressive strength (ASD), N

P_u = required compressive strength (LFRD), N

P_y = axial yield strength, N

$\phi_b = 0.90$

$\Omega_b = 1.67$

10.20.8.5.1 Required axial strength

The required axial strength of column bases, including their attachment to the foundation, shall be the summation of the vertical components of the required strengths of the steel elements that are connected to the column base.

10.20.8.5.2 Required shear strength

The required shear strength of column bases, including their attachments to the foundations, shall be the summation of the horizontal component of the required strengths of the steel elements that are connected to the column base as follows:

- (1) For diagonal bracing, the horizontal component shall be determined from the required strength of bracing connections for the seismic load resisting system (SLRS).
- (2) For columns, the horizontal component shall be at least equal to the lesser of the following:
 - (a) $2R_y F_y Z_x / H$ (LRFD) or $(2/1.5)R_y F_y Z_x / H$ (ASD), as appropriate, of the column

Where, H = height of story, which may be taken as the distance between the centerline of floor framing at each of the levels above and below, or the distance between the top of floor slabs at each of the levels above and below, mm.

- (b) The shear calculated using the load combinations of the applicable building Code, including the amplified seismic load.

10.20.8.5.3 Required flexural strength

The required flexural strength of column bases, including their attachment to the foundation, shall be the summation of the required strengths of the steel elements that are connected to the column base as follows:

- (1) For diagonal bracing, the required flexural strength shall be at least equal to the required strength of bracing connections for the SLRS.
- (2) For columns, the required flexural strength shall be at least equal to the lesser of the following:
 - (a) $1.1R_y F_y Z$ (LRFD) or $(1.1/1.5)R_y F_y Z$ (ASD), as appropriate, of the column
or
 - (b) moment calculated using the load combinations of the Code, including the amplified seismic load.

10.20.8.6 H-piles

10.20.8.6.1 Design of H-piles

Design of H-piles shall comply with the provisions of the Specification regarding design of members subjected to combined loads. H-piles shall meet the requirements of Sec 10.20.8.2.2.

10.20.8.6.2 Battered H-piles

If battered (sloped) and vertical piles are used in a pile group, the vertical piles shall be designed to support the combined effects of the dead and live loads without the participation of the battered piles.

10.20.8.6.3 Tension in H-piles

Tension in each pile shall be transferred to the pile cap by mechanical means such as shear keys, reinforcing bars or studs welded to the embedded portion of the pile. Directly below the bottom of the pile cap, each pile shall be free of attachments and welds for a length at least equal to the depth of the pile cross-section.

10.20.9 Special Moment Frames (SMF)

10.20.9.1 Scope

Special moment frames (SMF) are expected to withstand significant inelastic deformations when subjected to the forces resulting from the motions of the design earthquake. SMF shall satisfy the requirements in this Section.

10.20.9.2 Beam-to-column connections

10.20.9.2.1 Requirements

Beam-to-column connections used in the seismic load resisting system (SLRS) shall satisfy the following three requirements:

- (1) The connection shall be capable of sustaining an interstory drift angle of at least 0.04 radians.
- (2) The measured flexural resistance of the connection, determined at the column face, shall equal at least $0.80M_p$ of the connected beam at an interstory drift angle of 0.04 radians.

- (3) The required shear strength of the connection shall be determined using the following quantity for the earthquake load effect E :

$$E = 2[1.1R_yM_p]/L_h \quad (6.10.298)$$

Where,

R_y = ratio of the expected yield stress to the specified minimum yield stress, F_y

M_p = nominal plastic flexural strength, (N-mm)

L_h = distance between plastic hinge locations, (mm)

When E as in Eq. 6.10.298 is used in ASD load combinations that are additive with other transient loads and that are based on Chapter 2 Part 6, the 0.75 combination factor for transient loads shall not be applied to E .

Connections that accommodate the required interstory drift angle within the connection elements and provide the measured flexural resistance and shear strengths specified above are permitted. In addition to satisfying the requirements noted above, the design shall demonstrate that any additional drift due to connection deformation can be accommodated by the structure. The design shall include analysis for stability effects of the overall frame, including second-order effects.

10.20.9.2.2 Conformance demonstration

Beam-to-column connections used in the SLRS shall satisfy the requirements of Sec 10.20.9.2.1 by one of the following:

- (a) Use of SMF connections designed in accordance with ANSI/AISC 358.
- (b) Use of a connection prequalified for SMF in accordance with Appendix N.
- (c) Provision of qualifying cyclic test results in accordance with Appendix Q.

Results of at least two cyclic connection tests shall be provided and are permitted to be based on one of the following:

- (i) Tests reported in the research literature or documented tests performed for other projects that represent the project conditions, within the limits specified in Appendix Q.
- (ii) Tests that are conducted specifically for the project and are representative of project member sizes, material strengths, connection configurations, and matching connection processes, within the limits specified in Appendix Q.

10.20.9.2.3 Welds

Unless otherwise designated by ANSI/AISC 358, or otherwise determined in a connection prequalification in accordance with Appendix N, or as determined in a program of qualification testing in accordance with Appendix Q, complete-joint-penetration groove welds of beam flanges, shear plates, and beam webs to columns shall be demand critical welds as described in Sec 10.20.7.3.2.

10.20.9.2.4 Protected zones

The region at each end of the beam subject to inelastic straining shall be designated as a protected zone, and shall meet the requirements of Sec 10.20.7.4. The extent of the protected zone shall be as designated in ANSI/AISC 358, or as otherwise determined in a connection prequalification in accordance with Appendix N, or as determined in a program of qualification testing in accordance with Appendix Q.

10.20.9.3 Panel zone of beam-to-column connections (beam web parallel to column web)

10.20.9.3.1 Shear strength

The required thickness of the panel zone shall be determined in accordance with the method used in proportioning the panel zone of the tested or prequalified connection. As a minimum, the required shear strength of the panel zone shall be determined from the summation of the moments at the column faces as determined by projecting the expected moments at the plastic hinge points to the column faces. The design shear strength shall be $\phi_v R_v$ and the allowable shear strength shall be R_v/Ω_v .

Where, $\phi_v = 1.0$ (LRFD) $\Omega_v = 1.50$ (ASD)

And, the nominal shear strength, R_v , according to the limit state of shear yielding, is determined as specified in Specification Sec 10.10.10.6.

10.20.9.3.2 Panel zone thickness

The individual thicknesses, t , of column webs and doubler plates, if used, shall conform to the following requirement:

$$t \geq (d_z + w_z)/90 \quad (6.10.299)$$

Where,

t = thickness of column web or doubler plate, mm

d_z = panel zone depth between continuity plates, mm

w_z = panel zone width between column flanges, mm

Alternatively, when local buckling of the column web and doubler plate is prevented by using plug welds joining them, the total panel zone thickness shall satisfy Eq. 6.10.299.

10.20.9.3.3 Panel zone doubler plates

Doubler plates shall be welded to the column flanges using either a complete-joint-penetration groove-welded or fillet-welded joint that develops the available shear strength of the full doubler plate thickness. When doubler plates are placed against the column web, they shall be welded across the top and bottom edges to develop the proportion of the total force that is transmitted to the doubler plate. When doubler plates are placed away from the column web, they shall be placed symmetrically in pairs and welded to continuity plates to develop the proportion of the total force that is transmitted to the doubler plate.

10.20.9.4 Beam and column limitations

The requirements of Sec 10.20.8.1 shall be satisfied, in addition to the following.

10.20.9.4.1 Width-thickness limitations

Beam and column members shall meet the requirements of Sec 10.20.8.2.2, unless otherwise qualified by tests.

10.20.9.4.2 Beam flanges

Abrupt changes in beam flange area are not permitted in plastic hinge regions. The drilling of flange holes or trimming of beam flange width is permitted if testing or qualification demonstrates that the resulting configuration can develop stable plastic hinges. The configuration shall be consistent with a prequalified connection designated in ANSI/AISC 358, or as otherwise determined in a connection prequalification in accordance with Appendix N, or in a program of qualification testing in accordance with Appendix Q.

10.20.9.5 Continuity plates

Continuity plates shall be consistent with the prequalified connection designated in ANSI/AISC 358, or as otherwise determined in a connection prequalification in accordance with Appendix N, or as determined in a program of qualification testing in accordance with Appendix Q.

10.20.9.6 Column-beam moment ratio

The following relationship shall be satisfied at beam-to-column connections:

$$\frac{\sum M_{pc}^*}{\sum M_{pb}^*} > 1.0 \quad (6.10.300)$$

$\sum M_{pc}^*$ = the sum of the moments in the column above and below the joint at the intersection of the beam and column centerlines. $\sum M_{pc}^*$ is determined by summing the projections of the nominal flexural strengths of the columns (including haunches where used) above and below the joint to the beam centerline with a reduction for the axial force in the column. It is permitted to take $\sum M_{pc}^* = \sum Z_c (F_{yc} - P_{uc}/A_g)$ (LRFD) or $\sum Z_c (F_{yc}/1.5 - P_{ac}/A_g)$ (ASD), as appropriate. When the centerlines of opposing beams in the same joint do not coincide, the mid-line between centerlines shall be used.

$\sum M_{pb}^*$ = the sum of the moments in the beams at the intersection of the beam and column centerlines. $\sum M_{pb}^*$ is determined by summing the projections of the expected flexural strengths of the beams at the plastic hinge locations to the column centerline. It is permitted to take $\sum M_{pb}^* = \sum (1.1R_y F_{yb} Z_b + M_{uv})$ (LRFD) or $\sum M_{pb}^* = \sum [(1.1/1.5)R_y F_{yb} Z_b + M_{av}]$ (ASD), as appropriate. Alternatively, it is permitted to determine $\sum M_{pb}^*$ consistent with a prequalified connection design as designated in ANSI/AISC 358, or as otherwise determined in a connection prequalification in accordance with Appendix N, or in a program of qualification testing in accordance with Appendix Q. When connections with reduced beam sections are used, it is permitted to take $\sum M_{pb}^* = \sum (1.1R_y F_{yb} Z_{RBS} + M_{uv})$ (LRFD) or $\sum M_{pb}^* = \sum [(1.1/1.5)R_y F_{yb} Z_{RBS} + M_{av}]$ (ASD), as appropriate.

Where,

A_g = gross area of column, mm

F_{yc} = specified minimum yield stress of column, MPa

M_{av} = the additional moment due to shear amplification from the location of the plastic hinge to the column centerline, based on ASD load combinations, N-mm.

M_{uv} = the additional moment due to shear amplification from the location of the plastic hinge to the column centerline, based on LRFD load combinations, N-mm

P_{ac} = required compressive strength using ASD load combinations, (positive number) N.

P_{uc} = required compressive strength using LRFD load combinations, (positive number) N

Z_b = plastic section modulus of the beam, mm³

Z_c = plastic section modulus of the column, mm³

Z_{RBS} = minimum plastic section modulus at the reduced beam section, mm³

Exception:

This requirement does not apply if either of the following two conditions is satisfied:

- (a) Columns with $P_{rc} < 0.3P_c$ for all load combinations other than those determined using the amplified seismic load that satisfy either of the following:
 - (i) Columns used in a one-story building or the top story of a multistory building.
 - (ii) Columns where: (1) the sum of the available shear strengths of all exempted columns in the story is less than 20 percent of the sum of the available shear strengths of all moment frame columns in the story acting in the same direction; and (2) the sum of the available shear strengths of all exempted columns on each moment frame column line within that story is less than 33 percent of the available shear strength of all moment frame columns on that column line. For the purpose of this exception, a column line is defined as a single line of columns or parallel lines of columns located within 10 percent of the plan dimension perpendicular to the line of columns.

Where,

For design according to Specification Sec 10.2.3.3 (LRFD),

$$P_c = F_{yc}A_g, \text{ N}$$

$$P_{rc} = P_{uc}, \text{ required compressive strength, using LRFD load combinations, N}$$

For design according to Specification Sec 10.2.3.4 (ASD),

$$P_c = F_{yc}A_g/1.5, \text{ N}$$

$$P_{rc} = P_{ac}, \text{ required compressive strength, using ASD load combinations, N}$$

- (b) Columns in any story that has a ratio of available shear strength to required shear strength that is 50 percent greater than the story above.

10.20.9.7 Lateral bracing at beam-to-column connections

10.20.9.7.1 Braced connections

Column flanges at beam-to-column connections require lateral bracing only at the level of the top flanges of the beams, when the webs of the beams and column are co-planar, and a column is shown to remain elastic outside of the panel zone. It shall be permitted to assume that the column remains elastic when the ratio calculated using Eq. 6.10.300 is greater than 2.0.

When a column cannot be shown to remain elastic outside of the panel zone, following requirements shall apply:

The column flanges shall be laterally braced at the levels of both the top and bottom beam flanges. Lateral bracing shall be either direct or indirect.

Each column-flange lateral brace shall be designed for a required strength that is equal to 2 percent of the available beam flange strength $F_y b_f t_{bf}$ (LRFD) or $F_y b_f t_{bf}/1.5$ (ASD), as appropriate.

10.20.9.7.2 Unbraced connections

A column containing a beam-to-column connection with no lateral bracing transverse to the seismic frame at the connection shall be designed using the distance between adjacent lateral braces as the column height for buckling transverse to the seismic frame and shall conform to Specification Sec 10.8, except that:

- (1) The required column strength shall be determined from the appropriate load combinations, except that E shall be taken as the lesser of:
 - (a) The amplified seismic load.
 - (b) 125 percent of the frame available strength based upon either the beam available flexural strength or panel zone available shear strength.

- (2) The slenderness L/r for the column shall not exceed 60.
- (3) The column required flexural strength transverse to the seismic frame shall include that moment caused by the application of the beam flange force specified in Sec 10.20.9.7.1.(2) in addition to the second-order moment due to the resulting column flange displacement.

10.20.9.8 Lateral bracing of beams

Both flanges of beams shall be laterally braced, with a maximum spacing of $L_b = 0.086r_y E/F_y$. Braces shall meet the provisions of Eq. 6.10.291 and 6.10.292 of Sec 10.19, where $M_r = M_u = R_y Z F_y$ (LRFD) or $M_r = M_a = R_y Z F_y / 1.5$ (ASD), as appropriate, of the beam and $C_d = 1.0$.

In addition, lateral braces shall be placed near concentrated forces, changes in cross-section, and other locations where analysis indicates that a plastic hinge will form during inelastic deformations of the SMF. The placement of lateral bracing shall be consistent with that documented for a prequalified connection designated in ANSI/AISC 358, or as otherwise determined in a connection prequalification in accordance with Appendix N, or in a program of qualification testing in accordance with Appendix Q.

The required strength of lateral bracing provided adjacent to plastic hinges shall be $P_u = 0.06M_u/h_o$ (LRFD) or $P_a = 0.06M_a/h_o$ (ASD), as appropriate, where h_o is the distance between flange centroids; and the required stiffness shall meet the provisions of Eq. 6.10.292 of Sec 10.19.

10.20.9.9 Column splices

Column splices shall comply with the requirements of Sec 10.20.8.4.1. Where groove welds are used to make the splice, they shall be complete-joint-penetration groove welds that meet the requirements of Sec 10.20.7.3.2. Weld tabs shall be removed. When column splices are not made with groove welds, they shall have a required flexural strength that is at least equal to $R_y F_y Z_x$ (LRFD) or $R_y F_y Z_x / 1.5$ (ASD), as appropriate, of the smaller column. The required shear strength of column web splices shall be at least equal to $\sum M_{pc} / H$ (LRFD) or $\sum M_{pc} / (1.5H)$ (ASD), as appropriate, where $\sum M_{pc}$ is the sum of the nominal plastic flexural strengths of the columns above and below the splice.

Exception:

The required strength of the column splice considering appropriate stress concentration factors or fracture mechanics stress intensity factors need not exceed that determined by inelastic analyses.

10.20.10 Intermediate Moment Frames (IMF)

10.20.10.1 Scope

Intermediate moment frames (IMF) are expected to withstand limited inelastic deformations in their members and connections when subjected to the forces resulting from the motions of the design earthquake. IMF shall meet the requirements in this Section.

10.20.10.2 Beam-to-column connections

10.20.10.2.1 Requirements

Beam-to-column connections used in the seismic load resisting system (SLRS) shall satisfy the requirements of Sec 10.20.9.2.1, with the following exceptions:

- (1) The required interstory drift angle shall be a minimum of 0.02 radian.
- (2) The required strength in shear shall be determined as specified in Sec 10.20.9.2.1, except that a lesser value of V_u or V_a , as appropriate, is permitted if justified by analysis. The required shear strength need not exceed the shear resulting from the application of appropriate load combinations using the amplified seismic load.

10.20.10.2.2 Conformance demonstration

Conformance demonstration shall be as described in Sec 10.20.9.2.2 to satisfy the requirements of Sec 10.20.10.2.1 for IMF, except that a connection prequalified for IMF in accordance with ANSI/AISC 358, or as otherwise determined in a connection prequalification in accordance with Appendix N, or as determined in a program of qualification testing in accordance with Appendix Q.

10.20.10.2.3 Welds

Unless otherwise designated by ANSI/AISC 358, or otherwise determined in a connection prequalification in accordance with Appendix N, or as determined in a program of qualification testing in accordance with Appendix Q, complete joint penetration groove welds of beam flanges, shear plates, and beam webs to columns shall be demand critical welds as described in Sec 10.20.7.3.2.

10.20.10.2.4 Protected zone

The region at each end of the beam subject to inelastic straining shall be treated as a protected zone, and shall meet the requirements of Sec 10.20.7.4. The extent of the protected zone shall be as designated in ANSI/AISC 358, or as otherwise determined in a connection prequalification in accordance with Appendix N, or as determined in a program of qualification testing in accordance with Appendix Q.

10.20.10.3 Panel zone of beam-to-column connections (beam web parallel to column web)

No additional requirements beyond the specification.

10.20.10.4 Beam and column limitations

The requirements of Sec 10.20.8.1 shall be satisfied, in addition to the following.

10.20.10.4.1 Width-thickness limitations

Beam and column members shall meet the requirements of Sec 10.20.8.2.1, unless otherwise qualified by tests.

10.20.10.4.2 Beam flanges

Abrupt changes in beam flange area are not permitted in plastic hinge regions. Drilling of flange holes or trimming of beam flange width is permitted if testing or qualification demonstrates that the resulting configuration can develop stable plastic hinges. The configuration shall be consistent with a prequalified connection designated in ANSI/AISC 358, or as otherwise determined in a connection prequalification in accordance with Appendix N, or in a program of qualification testing in accordance with Appendix Q.

10.20.10.5 Continuity plates

Continuity plates shall be provided to be consistent with the prequalified connections designated in ANSI/AISC 358, or as otherwise determined in a connection prequalification in accordance with Appendix N, or as determined in a program of qualification testing in accordance with Appendix Q.

10.20.10.6 Column-beam moment ratio

No additional requirements beyond the Specification.

10.20.10.7 Lateral bracing at beam-to-column connections

No additional requirements beyond the Specification.

10.20.10.8 Lateral bracing of beams

Both flanges shall be laterally braced directly or indirectly. The unbraced length between lateral braces shall not exceed $0.17r_y E/F_y$. Braces shall meet the provisions of Equations 6.10.291 and 6.10.292 of Sec 10.19, where $M_r = M_u = R_y Z F_y$ (LRFD) or $M_r = M_a = R_y Z F_y / 1.5$ (ASD), as appropriate, of the beam, and $C_d = 1.0$.

In addition, lateral braces shall be placed near concentrated loads, changes in cross-section and other locations where analysis indicates that a plastic hinge will form during inelastic deformations of the IMF. Where the design is based upon assemblies tested in accordance with Appendix Q, the placement of lateral bracing for the beams shall be consistent with that used in the tests or as required for prequalification in Appendix N. The required strength of lateral bracing provided adjacent to plastic hinges shall be $P_u = 0.06M_u/h_o$ (LRFD) or $P_a = 0.06M_a/h_o$ (ASD), as appropriate, where h_o = distance between flange centroids; and the required stiffness shall meet the provisions of Eq. 6.10.292 of Sec 10.19.

10.20.10.9 Column splices

Column splices shall comply with the requirements of Sec 10.20.8.4.1. Where groove welds are used to make the splice, they shall be complete-joint-penetration groove welds that meet the requirements of Sec 10.20.7.3.2.

10.20.11 Ordinary Moment Frames (OMF)

10.20.11.1 Scope

Ordinary moment frames (OMF) are expected to withstand minimal inelastic deformations in their members and connections when subjected to the forces resulting from the motions of the design earthquake. OMF shall meet the requirements of this Section. Connections in conformance with Sections 10.20.9.2.1 and 10.20.9.5 or Sections 10.20.10.2.1 and 10.20.10.5 shall be permitted for use in OMF without meeting the requirements of Sections 10.20.11.2.1, 10.20.11.2.3, and 10.20.11.5

10.20.11.2 Beam-to-column connections

Beam-to-column connections shall be made with welds and/or high-strength bolts. Connections are permitted to be fully restrained (FR) or partially restrained (PR) moment connections as follows.

10.20.11.2.1 Requirements for FR moment connections

FR moment connections that are part of the seismic load resisting system (SLRS) shall be designed for a required flexural strength that is equal to $1.1R_yM_p$ (LRFD) or $(1.1/1.5)R_yM_p$ (ASD), as appropriate, of the beam or girder, or the maximum moment that can be developed by the system, whichever is less.

FR connections shall meet the following requirements.

- (1) Where steel backing is used in connections with complete-joint-penetration (CJP) beam flange groove welds, steel backing and tabs shall be removed, except that top-flange backing attached to the column by a continuous fillet weld on the edge below the CJP groove weld need not be removed. Removal of steel backing and tabs shall be as follows:
 - (i) Following the removal of backing, the root pass shall be back gouged to sound weld metal and back welded with a reinforcing fillet. The reinforcing fillet shall have a minimum leg size of 8 mm.
 - (ii) Weld tab removal shall extend to within 3 mm of the base metal surface, except at continuity plates where removal to within 6 mm of the plate edge is acceptable. Edges of the weld tab shall be finished to a surface roughness value of $13\ \mu\text{m}$ or better. Grinding to a flush condition is not required. Gouges and notches are not permitted. The transitional slope of any area where gouges and notches have been removed shall not exceed 1:5. Material removed by grinding that extends more than 2 mm below the surface of the base metal shall be filled with weld metal. The contour of the weld at the ends shall provide a smooth transition, free of notches and sharp corners.
- (2) Where weld access holes are provided, they shall be as shown in Figure 6.10.3. The weld access hole shall have a surface roughness value not to exceed $13\ \mu\text{m}$, and shall be free of notches and gouges. Notches and gouges shall be repaired as required by the engineer of record. Weld access holes are prohibited in the beam web adjacent to the end-plate in bolted moment end-plate connections.
- (3) The required strength of double-sided partial-joint-penetration groove welds and double-sided fillet welds that resist tensile forces in connections shall be $1.1R_yF_yA_g$ (LRFD) or $(1.1/1.5)R_yF_yA_g$ (ASD), as appropriate, of the connected element or part. Single-sided partial-joint-penetration groove welds and single-sided fillet welds shall not be used to resist tensile forces in the connections.

- (4) For FR moment connections, the required shear strength, V_u or V_a , as appropriate, of the connection shall be determined using the following quantity for the earthquake load effect E :

$$E = 2(1.1R_y M_p) / L_b \quad (6.10.301)$$

Where this E is used in ASD load combinations that are additive with other transient loads and that are based on Chapter 2 Part 6, the 0.75 combination factor for transient loads shall not be applied to E .

Alternatively, a lesser value of V_u or V_a is permitted if justified by analysis. The required shear strength need not exceed the shear resulting from the application of appropriate load combinations in the Code using the amplified seismic load.

10.20.11.2.2 Requirements for PR moment connections

PR moment connections are permitted when the following requirements are met:

- (1) Such connections shall be designed for the required strength as specified in Sec 10.20.11.2.1 above.
- (2) The nominal flexural strength of the connection, M_n , shall be no less than 50 percent of M_p of the connected beam or column, whichever is less.
- (3) The stiffness and strength of the PR moment connections shall be considered in the design, including the effect on overall frame stability.
- (4) For PR moment connections, V_u or V_a , as appropriate, shall be determined from the load combination above plus the shear resulting from the maximum end moment that the connection is capable of resisting.

10.20.11.2.3 Welds

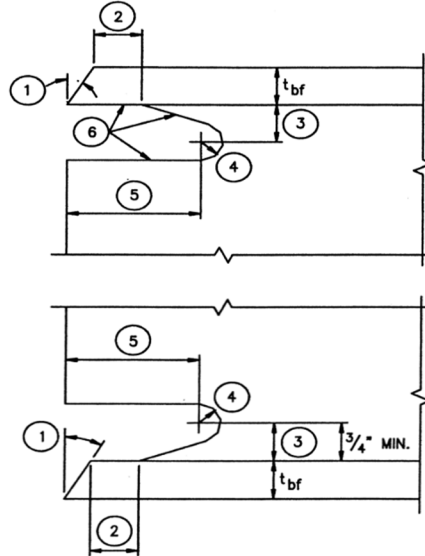
Complete-joint-penetration groove welds of beam flanges, shear plates, and beam webs to columns shall be demand critical welds as described in Sec 10.20.7.3.2.

10.20.11.3 Panel zone of beam-to-column connections (beam web parallel to column web)

No additional requirements beyond the Specification.

10.20.11.4 Beam and column limitations

No requirements beyond Sec 10.20.8.1.



Notes:

1. Bevel as required for selected groove weld.
2. Larger of t_{bf} or 13 mm (plus $\frac{1}{2} t_{bf}$, or minus $\frac{1}{4} t_{bf}$)
3. $\frac{3}{4} t_{bf}$ to t_{bf} , 19 mm minimum (± 6 mm)
4. 10 mm minimum radius (plus not limited, minus 0)
5. $3 t_{bf}$ (± 13 mm)

Tolerances shall not accumulate to the extent that the angle of the access hole cut to the flange surface exceeds 25° .

Figure 6.10.3. Weld access hole detail (FEMA 350)

10.20.11.5 Continuity plates

When FR moment connections are made by means of welds of beam flanges or beam-flange connection plates directly to column flanges, continuity plates shall be provided in accordance with Sec J10 of the Specification. Continuity plates shall also be required when:

$$t_{cf} < 0.54(b_f t_{bf} F_{yb} / F_{yc})^{1/2}$$

Or, when,

$$t_{cf} < b_f / 6$$

Where continuity plates are required, the thickness of the plates shall be determined as follows:

- (a) For one-sided connections, continuity plate thickness shall be at least one half of the thickness of the beam flange.
- (b) For two-sided connections the continuity plates shall be at least equal in thickness to the thicker of the beam flanges.

The welded joints of the continuity plates to the column flanges shall be made with either complete-joint-penetration groove welds, two-sided partial-joint-penetration groove welds combined with reinforcing fillet welds, or two-sided fillet welds. The required strength of these joints shall not be less than the available strength of the contact area of the plate with the column flange. The required strength of the welded joints of the continuity plates to the column web shall be the least of the following:

- (a) The sum of the available strengths at the connections of the continuity plate to the column flanges.
- (b) The available shear strength of the contact area of the plate with the column web.
- (c) The weld available strength that develops the available shear strength of the column panel zone.
- (d) The actual force transmitted by the stiffener.

10.20.11.6 Column-beam moment ratio

No requirements.

10.20.11.7 Lateral bracing at beam-to-column connections

No additional requirements beyond the Specification.

10.20.11.8 Lateral bracing of beams

No additional requirements beyond the Specification.

10.20.11.9 Column splices

Column splices shall comply with the requirements of Sec 10.20.8.4.1.

10.20.12 Special Truss Moment Frames (STMF)

10.20.12.1 Scope

Special truss moment frames (STMF) are expected to withstand significant inelastic deformation within a specially designed segment of the truss when subjected to the forces from the motions of the design earthquake. STMF shall be limited to span lengths between

columns not to exceed 20 m and overall depth not to exceed 1.8 m. The columns and truss segments outside of the special segments shall be designed to remain elastic under the forces that can be generated by the fully yielded and strain-hardened special segment. STMF shall meet the requirements in this Section.

10.20.12.2 Special segment

Each horizontal truss that is part of the seismic load resisting system (SLRS) shall have a special segment that is located between the quarter points of the span of the truss. The length of the special segment shall be between 0.1 and 0.5 times the truss span length. The length-to-depth ratio of any panel in the special segment shall neither exceed 1.5 nor be less than 0.67.

Panels within a special segment shall either be all Vierendeel panels or all X-braced panels; neither a combination thereof nor the use of other truss diagonal configurations is permitted. Where diagonal members are used in the special segment, they shall be arranged in an X pattern separated by vertical members. Such diagonal members shall be interconnected at points where they cross. The interconnection shall have a required strength equal to 0.25 times the nominal tensile strength of the diagonal member. Bolted connections shall not be used for web members within the special segment. Diagonal web members within the special segment shall be made of flat bars of identical sections.

Splicing of chord members is not permitted within the special segment, nor within one-half the panel length from the ends of the special segment. The required axial strength of the diagonal web members in the special segment due to dead and live loads within the special segment shall not exceed $0.03F_yA_g$ (LRFD) or $(0.03/1.5)F_yA_g$ (ASD), as appropriate. The special segment shall be a protected zone meeting the requirements of Sec 10.20.7.4.

10.20.12.3 Strength of special segment members

The available shear strength of the special segment shall be calculated as the sum of the available shear strength of the chord members through flexure, and the shear strength corresponding to the available tensile strength and 0.3 times the available compressive strength of the diagonal members, when they are used. The top and bottom chord members in the special segment shall be made of identical sections and shall provide at least 25 percent of the required vertical shear strength. The required axial strength in the chord members, determined according to the limit state of tensile yielding, shall not exceed 0.45 times ϕP_n (LRFD) or P_n/Ω (ASD), as appropriate,

$$\phi = 0.90 \text{ (LRFD)}$$

$$\Omega = 1.67 \text{ (ASD)}$$

Where, $P_n = F_y A_g$

The end connection of diagonal web members in the special segment shall have a required strength that is at least equal to the expected yield strength, in tension, of the web member, $R_y F_y A_g$ (LRFD) or $R_y F_y A_g / 1.5$ (ASD), as appropriate.

10.20.12.4 Strength of non-special segment members

Members and connections of STMF, except those in the special segment specified in Sec 10.20.12.2, shall have a required strength based on the appropriate load combinations in the Code, replacing the earthquake load term E with the lateral loads necessary to develop the expected vertical shear strength of the special segment V_{ne} (LRFD) or $V_{ne} / 1.5$ (ASD), as appropriate, at mid-length, given as:

$$V_{ne} = \frac{3.75 R_y M_{nc}}{L_s} + 0.075 EI \frac{L - L_s}{L_s^3} + R_y (P_{nt} + 0.3 P_{nc}) \sin \alpha \quad (6.10.302)$$

Where,

M_{nc} = nominal flexural strength of a chord member of the special segment,
N-mm

EI = flexural elastic stiffness of a chord member of the special segment, N-mm²

L = span length of the truss, mm

L_s = length of the special segment, mm

P_{nt} = nominal tensile strength of a diagonal member of the special segment, N

P_{nc} = nominal compressive strength of a diagonal member of the special segment,
N

α = angle of diagonal members with the horizontal

10.20.12.5 Width-thickness limitations

Chord members and diagonal web members within the special segment shall meet the requirements of Sec 10.20.8.2.2.

10.20.12.6 Lateral bracing

The top and bottom chords of the trusses shall be laterally braced at the ends of the special segment, and at intervals not to exceed L_p according to Specification Sec 10.6 along the entire length of the truss. The required strength of each lateral brace at the ends of and within the special segment shall be

$$P_u = 0.06R_yP_{nc} \text{ (LRFD) or } P_a = (0.06/1.5)R_yP_{nc} \text{ (ASD), as appropriate.}$$

Where, P_{nc} is the nominal compressive strength of the special segment chord member. Lateral braces outside of the special segment shall have a required strength of

$$P_u = 0.02R_yP_{nc} \text{ (LRFD) or } P_a = (0.02/1.5)R_yP_{nc} \text{ (ASD), as appropriate.}$$

The required brace stiffness shall meet the provisions of Eq. 6.10.288 of Sec 10.19.

Where, $P_r = P_u = R_yP_{nc}$ (LRFD) or $P_r = P_a = R_yP_{nc}/1.5$ (ASD), as appropriate.

10.20.13 Special Concentrically Braced Frames (SCBF)**10.20.13.1 Scope**

Special concentrically braced frames (SCBF) are expected to withstand significant inelastic deformations when subjected to the forces resulting from the motions of the design earthquake. SCBF shall meet the requirements in this Section.

10.20.13.2 Members**10.20.13.2.1 Slenderness**

Bracing members shall have $KI/r \leq 4\sqrt{(E/F_y)}$.

Exception :

Braces with $4\sqrt{(E/F_y)} < KI/r \leq 200$ are permitted in frames in which the available strength of the column is at least equal to the maximum load transferred to the column considering R_y (LRFD) or $(1/1.5)R_y$ (ASD), as appropriate, times the nominal strengths of the connecting brace elements of the building. Column forces need not exceed those determined by inelastic analysis, nor the maximum load effects that can be developed by the system.

10.20.13.2.2 Required strength

Where the effective net area of bracing members is less than the gross area, the required tensile strength of the brace based upon the limit state of fracture in the net section shall be greater than the lesser of the following:

- (a) The expected yield strength, in tension, of the bracing member, determined as $R_y F_y A_g$ (LRFD) or $R_y F_y A_g / 1.5$ (ASD), as appropriate.
- (b) The maximum load effect, indicated by analysis that can be transferred to the brace by the system.

10.20.13.2.3 Lateral force distribution

Along any line of bracing, braces shall be deployed in alternate directions such that, for either direction of force parallel to the bracing, at least 30 percent but no more than 70 percent of the total horizontal force along that line is resisted by braces in tension, unless the available strength of each brace in compression is larger than the required strength resulting from the application of the appropriate load combinations stipulated by the Code including the amplified seismic load. For the purposes of this provision, a line of bracing is defined as a single line or parallel lines with a plan offset of 10 percent or less of building dimension perpendicular to line of bracing.

10.20.13.2.4 Width-thickness limitations

Column and brace members shall meet the requirements of Sec 10.20.8.2.2.

10.20.13.2.5 Built-up members

The spacing of stitches shall be such that the slenderness ratio l/r of individual elements between the stitches does not exceed 0.4 times the governing slenderness ratio of the built-up member.

The sum of the available shear strengths of the stitches shall equal or exceed the available tensile strength of each element. The spacing of stitches shall be uniform. Not less than two stitches shall be used in a built-up member. Bolted stitches shall not be located within the middle one-fourth of the clear brace length.

Exception:

Where the buckling of braces about their critical buckling axis does not cause shear in the stitches, the spacing of the stitches shall be such that the slenderness ratio l/r of the individual elements between the stitches does not exceed 0.75 times the governing slenderness ratio of the built-up member.

10.20.13.3 Required strength of bracing connections

10.20.13.3.1 Required tensile strength

The required tensile strength of bracing connections (including beam-to-column connections if part of the bracing system) shall be the lesser of the following:

- (a) The expected yield strength, in tension, of the bracing member, determined as $R_y F_y A_g$ (LRFD) or $R_y F_y A_g / 1.5$ (ASD), as appropriate.
- (b) The maximum load effect, indicated by analysis that can be transferred to the brace by the system.

10.20.13.3.2 Required flexural strength

The required flexural strength of bracing connections shall be equal to $1.1 R_y M_p$ (LRFD) or $(1.1/1.5) R_y M_p$ (ASD), as appropriate, of the brace about the critical buckling axis.

Exception:

Brace connections that meet the requirements of Sec 10.20.13.3.1 and can accommodate the inelastic rotations associated with brace post-buckling deformations need not meet this requirement.

10.20.13.3.3 Required compressive strength

Bracing connections shall be designed for a required compressive strength based on buckling limit states that is at least equal to $1.1 R_y P_n$ (LRFD) or $(1.1/1.5) R_y P_n$ (ASD), as appropriate, where P_n is the nominal compressive strength of the brace.

10.20.13.4 Special bracing configuration requirements

10.20.13.4.1 V-type and inverted-V-type bracing

V-type and inverted V-type SCBF shall meet the following requirements:

- (1) The required strength of beams intersected by braces, their connections, and supporting members shall be determined based on the load combinations of the Code assuming that the braces provide no support for dead and live loads. For load combinations that include earthquake effects, the earthquake effect, E , on the beam shall be determined as follows:
 - (a) The forces in all braces in tension shall be assumed to be equal to $R_y F_y A_g$.
 - (b) The forces in all adjoining braces in compression shall be assumed to be equal to $0.3P_n$.
- (2) Beams shall be continuous between columns. Both flanges of beams shall be laterally braced, with a maximum spacing of $L_b = L_{pd}$, as specified by Equations 6.10.270 and 6.10.271 of Sec 10.15. Lateral braces shall meet the provisions of Equations 6.10.291 and 6.10.292 of Sec 10.19, where $M_r = M_u = R_y Z F_y$ (LRFD) or $M_r = M_a = R_y Z F_y / 1.5$ (ASD), as appropriate, of the beam and $C_d = 1.0$.

As a minimum, one set of lateral braces is required at the point of intersection of the V-type (or inverted V-type) bracing, unless the beam has sufficient out-of-plane strength and stiffness to ensure stability between adjacent brace points.

10.20.13.4.2 K-type bracing

K-type braced frames are not permitted for SCBF.

10.20.13.5 Column splices

In addition to meeting the requirements in Sec 10.20.8.4, column splices in SCBF shall be designed to develop 50 percent of the lesser available flexural strength of the connected members. The required shear strength shall be $\sum M_{pc} / H$ (LRFD) or $\sum M_{pc} / 1.5H$ (ASD), as appropriate, where $\sum M_{pc}$ is the sum of the nominal plastic flexural strengths of the columns above and below the splice.

10.20.13.6 Protected zone

The protected zone of bracing members in SCBF shall include the center one-quarter of the brace length, and a zone adjacent to each connection equal to the brace depth in the plane of buckling. The protected zone of SCBF shall include elements that connect braces to beams and columns and shall satisfy the requirements of Sec 10.20.7.4.

10.20.14 Ordinary Concentrically Braced Frames (OCBF)**10.20.14.1 Scope**

Ordinary concentrically braced frames (OCBF) are expected to withstand limited inelastic deformations in their members and connections when subjected to the forces resulting from the motions of the design earthquake. OCBF shall meet the requirements in this Section. OCBF above the isolation system in seismically isolated structures shall meet the requirements of Sections 10.20.14.4 and 10.20.14.5 and need not meet the requirements of Sections 10.20.14.2 and 10.20.14.3.

10.20.14.2 Bracing members

Bracing members shall meet the requirements of Sec 10.20.8.2.2.

Exception:

HSS braces that are filled with concrete need not comply with this provision.

Bracing members in K, V, or inverted-V configurations shall have $KL/r \leq 4 \sqrt{(E/F_y)}$.

10.20.14.3 Special bracing configuration requirements

Beams in V-type and inverted V-type OCBF and columns in K-type OCBF shall be continuous at bracing connections away from the beam-column connection and shall meet the following requirements:

- (1) The required strength shall be determined based on the load combinations of the Code assuming that the braces provide no support of dead and live loads. For load combinations that include earthquake effects, the earthquake effect, E, on the member shall be determined as follows:
 - (a) The forces in braces in tension shall be assumed to be equal to $R_y F_y A_g$. For V-type and inverted V-type OCBF, the forces in braces in tension need not exceed the maximum force that can be developed by the system.
 - (b) The forces in braces in compression shall be assumed to be equal to $0.3P_n$.
- (2) Both flanges shall be laterally braced, with a maximum spacing of $L_b = L_{pd}$, as specified by Equations 6.10.270 and 6.10.271 of Sec 10.15. Lateral braces shall meet the provisions of Equations 6.10.291 and 6.10.292 of Sec 10.19, where $M_r = M_u = R_y Z F_y$ (LRFD) or $M_r = M_a = R_y Z F_y / 1.5$ (ASD), as appropriate, of the beam

and $C_d = 1.0$. As a minimum, one set of lateral braces is required at the point of intersection of the bracing, unless the member has sufficient out-of-plane strength and stiffness to ensure stability between adjacent brace points.

10.20.14.4 Bracing connections

The required strength of bracing connections shall be determined as follows.

- (1) For the limit state of bolt slip, the required strength of bracing connections shall be that determined using the load combinations stipulated by the Code, not including the amplified *seismic load*.
- (2) For other limit states, the required strength of bracing connections is the *expected yield strength*, in tension, of the brace, determined as $R_y F_y A_g$ (LRFD) or $R_y F_y A_g / 1.5$ (ASD), as appropriate.

Exception:

The required strength of the brace connection need not exceed either of the following:

- (a) The maximum force that can be developed by the system
- (b) A load effect based upon using the amplified seismic load

10.20.14.5 OCBF above seismic isolation systems

10.20.14.5.1 Bracing members

Bracing members shall meet the requirements of Sec 10.20.8.2.2 and shall have

$$KL/r \leq 4\sqrt{(E/F_y)}.$$

10.20.14.5.2 K-type bracing

K-type braced frames are not permitted.

10.20.14.5.3 V-type and inverted-V-type bracing

Beams in V-type and inverted V-type bracing shall be continuous between columns.

10.20.15 Eccentrically Braced Frames (EBF)**10.20.15.1 Scope**

Eccentrically braced frames (EBFs) are expected to withstand significant inelastic deformations in the links when subjected to the forces resulting from the motions of the design earthquake. The diagonal braces, columns, and beam segments outside of the links shall be designed to remain essentially elastic under the maximum forces that can be generated by the fully yielded and strain-hardened links, except where permitted in this Section. In buildings exceeding five stories in height, the upper story of an EBF system is permitted to be designed as an OCBF or a SCBF and still be considered to be part of an EBF system for the purposes of determining system factors in the Code. EBF shall meet the requirements in this Section.

10.20.15.2 Links**10.20.15.2.1 Limitations**

Links shall meet the requirements of Sec 10.20.8.2.2.

The web of a link shall be single thickness. Doubler-plate reinforcement and web penetrations are not permitted.

10.20.15.2.2 Shear strength

Except as limited below, the link design shear strength, $\phi_v V_n$ and the allowable shear strength, V_n/Ω_v , according to the limit state of shear yielding shall be determined as follows:

V_n = nominal shear strength of the link, equal to the lesser of V_p or $2M_p/e$, N

$$\phi_v = 0.90 \text{ (LRFD)} \quad \Omega_v = 1.67 \text{ (ASD)}$$

Where,

$$M_p = F_y Z, \text{ N-mm}$$

$$V_p = 0.6 F_y A_w, \text{ N}$$

e = link length, mm

$$A_w = (d - 2t_f)t_w$$

The effect of axial force on the link available shear strength need not be considered if

$$P_u \leq 0.15P_y \quad (\text{LRFD}) \quad \text{or} \quad P_a \leq (0.15/1.5)P_y \quad (\text{ASD}),$$

as appropriate.

Where,

P_u = required axial strength using LRFD load combinations, N

P_a = required axial strength using ASD load combinations, N

P_y = nominal axial yield strength = $F_y A_g$, N

If $P_u > 0.15P_y$ (LRFD) or $P_a > (0.15/1.5)P_y$ (ASD), as appropriate, the following additional requirements shall be met:

(1) The available shear strength of the link shall be the lesser of

$$\phi_v V_{pa} \text{ and } 2\phi_v M_{pa}/e \quad (\text{LRFD})$$

Or,

$$V_{pa}/\Omega_v \text{ and } 2(M_{pa}/e)/\Omega_v \quad (\text{ASD}), \text{ as appropriate,}$$

Where,

$$\phi_v = 0.90 \quad (\text{LRFD}), \quad \Omega_v = 1.67 \quad (\text{ASD})$$

$$V_{pa} = V_p \sqrt{(1 - (P_r/P_c))^2} \quad (6.10.303)$$

$$M_{pa} = 1.18M_p [1 - (P_r/P_c)] \quad (6.10.304)$$

$$P_r = P_u \quad (\text{LRFD}) \text{ or } P_a \quad (\text{ASD}), \text{ as appropriate}$$

$$P_c = P_y \quad (\text{LRFD}) \text{ or } P_y/1.5 \quad (\text{ASD}), \text{ as appropriate}$$

(2) The length of the link shall not exceed:

$$(a) \quad [1.15 - 0.5\rho'(A_w/A_g)]1.6M_p/V_p \text{ when } \rho'(A_w/A_g) \geq 0.3 \\ (6.10.305)$$

Nor,

$$(b) \quad 1.6M_p/V_p \text{ when } \rho'(A_w/A_g) < 0.3 \\ (6.10.306)$$

Where,

$$A_w = (d - 2t_f)t_w$$

$$\rho' = P_r/V_r$$

And where,

$$V_r = V_u \text{ (LRFD) or } V_r = V_a \text{ (ASD), as appropriate}$$

V_u = required shear strength based on LRFD load combinations.

V_a = required shear strength based on ASD load combinations.

10.20.15.2.3 Link rotation angle

The link rotation angle is the inelastic angle between the link and the beam outside of the link when the total story drift is equal to the design story drift, Δ . The link rotation angle shall not exceed the following values:

- (a) 0.08 radians for links of length $1.6M_p/V_p$ or less.
- (b) 0.02 radians for links of length $2.6M_p/V_p$ or greater.
- (c) The value determined by linear interpolation between the above values for links of length between $1.6M_p/V_p$ and $2.6M_p/V_p$.

10.20.15.3 Link stiffeners

Full-depth web stiffeners shall be provided on both sides of the link web at the diagonal brace ends of the link. These stiffeners shall have a combined width not less than $(b_f - 2t_w)$ and a thickness not less than $0.75t_w$ or 10 mm, whichever is larger, where b_f and t_w are the link flange width and link web thickness, respectively.

Links shall be provided with intermediate web stiffeners as follows:

- (a) Links of lengths $1.6M_p/V_p$ or less shall be provided with intermediate web stiffeners spaced at intervals not exceeding $(30t_w - d/5)$ for a link rotation angle of 0.08 radian or $(52t_w - d/5)$ for link rotation angles of 0.02 radian or less. Linear interpolation shall be used for values between 0.08 and 0.02 radian.
- (b) Links of length greater than $2.6M_p/V_p$ and less than $5M_p/V_p$ shall be provided with intermediate web stiffeners placed at a distance of 1.5 times b_f from each end of the link.
- (c) Links of length between $1.6M_p/V_p$ and $2.6M_p/V_p$ shall be provided with intermediate web stiffeners meeting the requirements of (a) and (b) above.
- (d) Intermediate web stiffeners are not required in links of lengths greater than $5M_p/V_p$.
- (e) Intermediate web stiffeners shall be full depth. For links that are less than 635 mm in depth, stiffeners are required on only one side of the link web. The thickness of one-sided stiffeners shall not be less than t_w or 10 mm, whichever is larger, and the width shall be not less than $(b_f/2)t_w$. For links that are 635 mm in depth or greater, similar intermediate stiffeners are required on both sides of the web.

The required strength of fillet welds connecting a link stiffener to the link web is $A_{st}F_y$ (LRFD) or $A_{st}F_y/1.5$ (ASD), as appropriate, where A_{st} is the area of the stiffener. The required strength of fillet welds connecting the stiffener to the link flanges is $A_{st}F_y/4$ (LRFD) or $A_{st}F_y/4(1.5)$ (ASD).

10.20.15.4 Link-to-column connections

Link-to-column connections must be capable of sustaining the maximum link rotation angle based on the length of the link, as specified in Sec 10.20.15.2.3. The strength of the connection measured at the column face shall equal at least the nominal shear strength of

the link, V_n , as specified in Sec 10.20.15.2.2 at the maximum link rotation angle. Link-to-column connections shall satisfy the above requirements by one of the following:

- (a) Use a connection prequalified for EBF in accordance with Appendix N.
- (b) Provide qualifying cyclic test results in accordance with Appendix Q. Results of at least two cyclic connection tests shall be provided and are permitted to be based on one of the following:
 - (i) Tests reported in research literature or documented tests performed for other projects that are representative of project conditions, within the limits specified in Appendix Q.
 - (ii) Tests that are conducted specifically for the project and are representative of project member sizes, material strengths, connection configurations, and matching connection processes, within the limits specified in Appendix Q.

Exception:

Where reinforcement at the beam-to-column connection at the link end precludes yielding of the beam over the reinforced length, the link is permitted to be the beam segment from the end of the reinforcement to the brace connection. Where such links are used and the link length does not exceed $1.6M_p/V_p$, cyclic testing of the reinforced connection is not required if the available strength of the reinforced section and the connection equals or exceeds the required strength calculated based upon the strain-hardened link as described in Sec 10.20.15.6. Full depth stiffeners as required in Sec 10.20.15.3 shall be placed at the link-to-reinforcement interface.

10.20.15.5 Lateral bracing of link

Lateral bracing shall be provided at both the top and bottom link flanges at the ends of the link. The required strength of each lateral brace at the ends of the link shall be $P_b = 0.06M_r/h_o$, where, h_o is the distance between flange centroids, in mm.

For design according to Specification Sec 10.2.3.3 (LRFD)

$$M_r = M_{u,exp} = R_y Z F_y$$

For design according to Specification Sec 10.2.3.4 (ASD)

$$M_r = M_{u,exp}/1.5$$

The required brace stiffness shall meet the provisions of Eq. 6.10.292 of Sec 10.19, where M_r is defined above, $C_d = 1$, and L_b is the link length.

10.20.15.6 Diagonal brace and beam outside of link

10.20.15.6.1 Diagonal brace

The required combined axial and flexural strength of the diagonal brace shall be determined based on load combinations stipulated by the Code. For load combinations including seismic effects, a load Q_1 shall be substituted for the term E , where Q_1 is defined as the axial forces and moments generated by at least 1.25 times the expected nominal shear strength of the link $R_y V_n$, where V_n is as defined in Sec 10.20.15.2.2. The available strength of the diagonal brace shall comply with Specification Sec 10.10. Brace members shall meet the requirements of Sec 10.20.8.2.1.

10.20.15.6.2 Beam outside link

The required combined axial and flexural strength of the beam outside of the link shall be determined based on load combinations stipulated by the Code. For load combinations including seismic effects, a load Q_1 shall be substituted for the term E where Q_1 is defined as the forces generated by at least 1.1 times the expected nominal shear strength of the link, $R_y V_n$, where V_n is as defined in Sec 10.20.15.2.2. The available strength of the beam outside of the link shall be determined by the Specification, multiplied by R_y .

At the connection between the diagonal brace and the beam at the link end of the brace, the intersection of the brace and beam centerlines shall be at the end of the link or in the link.

10.20.15.6.3 Bracing connections

The required strength of the diagonal brace connections, at both ends of the brace, shall be at least equal to the required strength of the diagonal brace, as defined in Sec 10.20.15.6.1. The diagonal brace connections shall also satisfy the requirements of Sec 10.20.13.3.3.

No part of the diagonal brace connection at the link end of the brace shall extend over the link length. If the brace is designed to resist a portion of the link end moment, then the diagonal brace connection at the link end of the brace shall be designed as a fully-restrained moment connection.

10.20.15.7 Beam-to-column connections

If the EBF system factors in the Code require moment resisting connections away from the link, then the beam-to-column connections away from the link shall meet the requirements

for beam-to-column connections for OMF specified in Sections 10.20.11.2 and 10.20.11.5.

If EBF system factors in the Code do not require moment resisting connections away from the link, then the beam-to-column connections away from the link are permitted to be designed as pinned in the plane of the web.

10.20.15.8 Required strength of columns

In addition to the requirements in Sec 10.20.8.3, the required strength of columns shall be determined from load combinations as stipulated by the Code, except that the seismic load E shall be the forces generated by 1.1 times the expected nominal shear strength of all links above the level under consideration. The expected nominal shear strength of a link is $R_y V_n$, where V_n is as defined in Sec 10.20.15.2.2. Column members shall meet the requirements of Sec 10.20.8.2.2.

10.20.15.9 Protected zone

Links in EBFs are a protected zone, and shall satisfy the requirements of Sec 10.20.7.4. Welding on links is permitted for attachment of link stiffeners, as required in Sec 10.20.15.3.

10.20.15.10 Demand critical welds

Complete-joint-penetration groove welds attaching the link flanges and the link web to the column are demand critical welds, and shall satisfy the requirements of Sec 10.20.7.3.2.

10.20.16 Buckling-Restrained Braced Frames (BRBF)

10.20.16.1 Scope

Buckling-restrained braced frames (BRBF) are expected to withstand significant inelastic deformations when subjected to the forces resulting from the motions of the design earthquake. BRBF shall meet the requirements in this Section. Where the Code does not contain design coefficients for BRBF, provisions of Appendix P shall apply.

10.20.16.2 Bracing members

Bracing members shall be composed of a structural steel core and a system that restrains the steel core from buckling.

10.20.16.2.1 Steel core

The steel core shall be designed to resist the entire axial force in the brace.

The brace design axial strength, $\phi P_{y_{sc}}$ (LRFD), and the brace allowable axial strength, $P_{y_{sc}}/\Omega$ (ASD), in tension and compression, according to the limit state of yielding, shall be determined as follows:

$$P_{y_{sc}} = F_{y_{sc}} = A_{sc} \quad (\text{Sec 10.20.16.1})$$

$$\phi = 0.90 \text{ (LRFD)} \quad \Omega = 1.67 \text{ (ASD)}$$

Where,

$F_{y_{sc}}$ = specified minimum yield stress of the steel core, or actual yield stress of the steel core as determined from a coupon test, MPa

A = net area of steel core, mm²

Plates used in the steel core that are 50 mm thick or greater shall satisfy the minimum notch toughness requirements of Sec 10.20.6.3.

Splices in the steel core are not permitted.

10.20.16.2.2 Buckling-restraining system

The buckling-restraining system shall consist of the casing for the steel core. In stability calculations, beams, columns, and gussets connecting the core shall be considered parts of this system.

The buckling-restraining system shall limit local and overall buckling of the steel core for deformations corresponding to 2.0 times the design story drift. The buckling-restraining system shall not be permitted to buckle within deformations corresponding to 2.0 times the design story drift.

10.20.16.2.3 Testing

The design of braces shall be based upon results from qualifying cyclic tests in accordance with the procedures and acceptance criteria of Appendix R. Qualifying test results shall consist of at least two successful cyclic tests: one is required to be a test of a brace sub-assembly that includes brace connection rotational demands complying with Appendix R, Sec R.4 and the other shall be either a uniaxial or a sub-assembly test complying with

Appendix R, Sec R.5. Both test types are permitted to be based upon one of the following:

- (a) Tests reported in research or documented tests performed for other projects.
- (b) Tests that are conducted specifically for the project.

Interpolation or extrapolation of test results for different member sizes shall be justified by rational analysis that demonstrates stress distributions and magnitudes of internal strains consistent with or less severe than the tested assemblies and that considers the adverse effects of variations in material properties. Extrapolation of test results shall be based upon similar combinations of steel core and buckling-restraining system sizes. Tests shall be permitted to qualify a design when the provisions of Appendix R are met.

10.20.16.2.4 Adjusted brace strength

Where required by these Provisions, bracing connections and adjoining members shall be designed to resist forces calculated based on the adjusted brace strength.

The adjusted brace strength in compression shall be $\beta\omega R_y P_{y_{sc}}$. The adjusted brace strength in tension shall be $\omega R_y P_{y_{sc}}$.

Exception:

The factor R_y need not be applied if $P_{y_{sc}}$ is established using yield stress determined from a coupon test. The compression strength adjustment factor, β , shall be calculated as the ratio of the maximum compression force to the maximum tension force of the test specimen measured from the qualification tests specified in Appendix R, Sec R.6.3 for the range of deformations corresponding to 2.0 times the design story drift. The larger value of β from the two required brace qualification tests shall be used. In no case shall β be taken as less than 1.0. The strain hardening adjustment factor, ω , shall be calculated as the ratio of the maximum tension force measured from the qualification tests specified in Appendix R, Sec R.6.3 (for the range of deformations corresponding to 2.0 times the design story drift) to $F_{y_{sc}}$ of the test specimen. The larger value of ω from the two required qualification tests shall be used. Where the tested steel core material does not match that of the prototype, ω shall be based on coupon testing of the prototype material.

10.20.16.3 Bracing connections

10.20.16.3.1 Required strength

The required strength of bracing connections in tension and compression (including beam-to-column connections if part of the bracing system) shall be 1.1 times the adjusted brace strength in compression (LRFD) or (1.1/1.5) times the adjusted brace strength in compression (ASD).

10.20.16.3.2 Gusset plates

The design of connections shall include considerations of local and overall buckling. Bracing consistent with that used in the tests upon which the design is based is required.

10.20.16.4 Special requirements related to bracing configuration

V-type and inverted-V-type braced frames shall meet the following requirements:

- (1) The required strength of beams intersected by braces, their connections, and supporting members shall be determined based on the load combinations of the Code assuming that the braces provide no support for dead and live loads. For load combinations that include earthquake effects, the vertical and horizontal earthquake effect, E, on the beam shall be determined from the adjusted brace strengths in tension and compression.
- (2) Beams shall be continuous between columns. Both flanges of beams shall be laterally braced. Lateral braces shall meet the provisions of Equations 6.10.291 and 6.10.292 of Sec 10.19, where, $M_r = M_u = R_y Z F_y$ (LRFD) or $M_r = M_a = R_y Z F_y / 1.5$ (ASD), as appropriate, of the beam and $C_d = 1.0$. As a minimum, one set of lateral braces is required at the point of intersection of the V-type (or inverted V-type) bracing, unless the beam has sufficient out-of-plane strength and stiffness to ensure stability between adjacent brace points.

For purposes of brace design and testing, the calculated maximum deformation of braces shall be increased by including the effect of the vertical deflection of the beam under the loading defined in Sec 10.20.16.4(1).

K-type braced frames are not permitted for BRBF.

10.20.16.5 Beams and columns

Beams and columns in BRBF shall meet the following requirements.

10.20.16.5.1 Width-thickness limitations

Beam and column members shall meet the requirements of Sec 10.20.8.2.2.

10.20.16.5.2 Required strength

The required strength of beams and columns in BRBF shall be determined from load combinations as stipulated in the Code. For load combinations that include earthquake effects, the earthquake effect, E , shall be determined from the adjusted brace strengths in tension and compression.

The required strength of beams and columns need not exceed the maximum force that can be developed by the system.

10.20.16.5.3 Splices

In addition to meeting the requirements in Sec 10.20.8.4, column splices in BRBF shall be designed to develop 50 percent of the lesser available flexural strength of the connected members, determined based on the limit state of yielding. The required shear strength shall be $\sum M_{pc}/H$ (LRFD) or $\sum M_{pc}/1.5H$ (ASD), as appropriate, where $\sum M_{pc}$ is the sum of the nominal plastic flexural strengths of the columns above and below the splice.

10.20.16.6 Protected zone

The protected zone shall include the steel core of bracing members and elements that connect the steel core to beams and columns, and shall satisfy the requirements of Sec 10.20.7.4.

10.20.17 Special Plate Shear Walls (SPSW)

10.20.17.1 Scope

Special plate shear walls (SPSW) are expected to withstand significant inelastic deformations in the webs when subjected to the forces resulting from the motions of the design earthquake. The horizontal boundary elements (HBEs) and vertical boundary elements (VBEs) adjacent to the webs shall be designed to remain essentially elastic under the maximum forces that can be generated by the fully yielded webs, except that plastic hinging at the ends of HBEs is permitted. SPSW shall meet the requirements of this Section. Where the Code does not contain design coefficients for SPSW, the provisions of Appendix P shall apply.

10.20.17.2 Webs

10.20.17.2.1 Shear strength

The panel design shear strength, ϕV_n (LRFD), and the allowable shear strength, V_n/Ω (ASD), according to the limit state of shear yielding, shall be determined as follows:

$$V_n = 0.42F_y t_w L_{cf} \sin 2\alpha \quad (6.10.307)$$

$$\phi = 0.90 \text{ (LRFD)} \quad \Omega = 1.67 \text{ (ASD)}$$

Where,

t_w = thickness of the web, mm.

L_{cf} = clear distance between VBE flanges, mm

α = angle of web yielding in radians, as measured relative to the vertical, and it is given by:

$$\tan^4 \alpha = \frac{1 + \frac{t_w L}{2A_c}}{1 + t_w h \left(\frac{1}{A_b} + \frac{h^3}{360I_c L} \right)} \quad (6.10.308)$$

h = distance between HBE centerlines, mm

A_b = cross-sectional area of a HBE, mm²

A_c = cross-sectional area of a VBE, mm²

I_c = moment of inertia of a VBE taken perpendicular to the direction of the web plate line, mm⁴

L = distance between VBE centerlines, mm

10.20.17.2.2 Panel aspect ratio

The ratio of panel length to height, L/h , shall be limited to $0.8 < L/h \leq 2.5$.

10.20.17.2.3 Openings in webs

Openings in webs shall be bounded on all sides by HBE and VBE extending the full width and height of the panel, respectively, unless otherwise justified by testing and analysis.

10.20.17.3 Connections of webs to boundary elements

The required strength of web connections to the surrounding HBE and VBE shall equal the expected yield strength, in tension, of the web calculated at an angle α , defined by Eq. 6.10.308.

10.20.17.4 Horizontal and vertical boundary elements

10.20.17.4.1 Required strength

In addition to the requirements of Sec 10.20.8.3, the required strength of VBE shall be based upon the forces corresponding to the expected yield strength, in tension, of the web calculated at an angle α .

The required strength of HBE shall be the greater of the forces corresponding to the expected yield strength, in tension, of the web calculated at an angle α or that determined from the load combinations in the Code assuming the web provides no support for gravity loads.

The beam-column moment ratio provisions in Sec 10.20.9.6 shall be met for all HBE/VBE intersections without consideration of the effects of the webs.

10.20.17.4.2 HBE-to-VBE connections

HBE-to-VBE connections shall satisfy the requirements of Sec 10.20.11.2. The required shear strength, V_u , of a HBE-to-VBE connection shall be determined in accordance with the provisions of Sec 10.20.11.2, except that the required shear strength shall not be less than the shear corresponding to moments at each end equal to $1.1R_yM_p$ (LRFD) or $(1.1/1.5)R_yM_p$ (ASD), as appropriate, together with the shear resulting from the expected yield strength in tension of the webs yielding at an angle α .

10.20.17.4.3 Width-thickness limitations

HBE and VBE members shall meet the requirements of Sec 10.20.8.2.2.

10.20.17.4.4 Lateral bracing

HBE shall be laterally braced at all intersections with VBE and at a spacing not to exceed $0.086r_y E/F_y$. Both flanges of HBE shall be braced either directly or indirectly. The required strength of lateral bracing shall be at least 2 percent of the HBE flange nominal strength, $F_y b_f t_f$. The required stiffness of all lateral bracing shall be determined in accordance with Eq. 6.10.292 of Sec 10.19. In these Equations, M_r shall be computed as $R_y Z F_y$ (LRFD) or M_r shall be computed as $R_y Z F_y / 1.5$ (ASD), as appropriate, and $C_d = 1.0$.

10.20.17.4.5 VBE splices

VBE splices shall comply with the requirements of Sec 10.20.8.4.

10.20.17.4.6 Panel zones

The VBE panel zone next to the top and base HBE of the SPSW shall comply with the requirements in Sec 10.20.9.3.

10.20.17.4.7 Stiffness of vertical boundary elements

The VBE shall have moments of inertia about an axis taken perpendicular to the plane of the web, I_c not less than $0.00307 t_w h^4 / L$.

10.20.18 Quality Assurance Plan

10.20.18.1 Scope

When required by the Code or the Engineer, a quality assurance plan shall be provided. The quality assurance plan shall include the requirements of Appendix O.

10.21 List of Related Appendices

Appendix N	Prequalification of Beam-Column and Link-to-Column Connections
Appendix O	Quality Assurance Plan
Appendix P	Seismic Design Coefficients and Approximate Period Parameters
Appendix Q	Qualifying Cyclic Tests of Beam-to-Column and Link-to-Column Connections
Appendix R	Qualifying Cyclic Tests of Buckling-restrained Braces
Appendix S	Welding Provisions
Appendix T	Weld Metal/Welding Procedure Specification Notch Toughness Verification Test

PART VI**Chapter 11****TIMBERS STRUCTURES****11.1 scope**

11.1.1 This Section relates to the use of structural timber in structures or elements of structures connected together by fasteners/fastening techniques.

11.1.2 This shall not be interpreted to prevent the use of material or methods of design or construction not specifically mentioned herein; and the methods of design may be based on analytical and engineering principles, or reliable test data, or both, that demonstrate the safety and serviceability of the resulting structure. Nor is the classification of timber into strength groups to be interpreted as preventing the use of design data desired for a particular timber or grade of timber on the basis of reliable tests.

11.2 Terminology

11.2.1 This Section provides an alphabetical list of the terms used in this Chapter of the Code. In case of any conflict or contradiction between a definition given in this Section and that in Part 1, the meaning provided in this Section shall govern for interpretation of the provisions of this Chapter.

11.2.2 Structural Purpose Definitions

BUILT-UP-LAMINATED BEAM	A beam made by joining layers of timber together with mechanical fastenings, so that the grain of all layers is essentially parallel.
DURATION OF LOAD	Period during which a member or a complete structure is stressed as a consequence of the loads applied.
EDGE DISTANCE	The distance measured perpendicular to grain from the centre of the connector to the edge of the member.
END DISTANCE	The distance measured parallel to grain of the member from the centre of the connector to the closest end of timber.
FINGER JOINT	Joint produced by connecting timber members end-to-end by cutting profiles (tapered projections) in the form of V-shaped grooves to the ends of timber planks or scantlings to be joined, gluing the interfaces and then mating the two ends together under pressure.

GLUED-LAMINATED BEAM	A beam made by bonding layers of veneers or timber with an adhesive, so that grain of all laminations is essentially parallel.
INSIDE LOCATION	Position in buildings in which timber remains continuously dry or protected from weather.
LAMINATED VENEER LUMBER	A structural composite made by laminating veneers, 1.5 mm to 4.2 mm thick, with suitable adhesive and with the grain of veneers in successive layers aligned along the longitudinal (length) dimension of the composite.
LOADED EDGE DISTANCE	The distance measured from the centre to the edge towards which the load induced by the connector acts, and the unloaded edge distance is the one opposite to the loaded edge.
LOCATION	A term generally referred to as exact place where a timber is used in building.
OUTSIDE LOCATION	Position in buildings in which timbers are occasionally subjected to wetting and drying as in the case of open sheds and outdoor exposed structures.
PERMANENT STRUCTURE	Structural units in timber which are constructed for a long duration and wherein adequate protection and design measures have initially been incorporated to render the structure serviceable for the required life.
PERMISSIBLE STRESS	Stress obtained by applying factor of safety to the ultimate stress.
SPACED COLUMN	Two column sections adequately connected together by glue, bolts, screws or otherwise.
STRUCTURAL DIAPHRAGM	A structural element of large extent placed in a building as a wall, or roof, and made use of to resist horizontal forces such as wind or earthquakes-acting parallel to its own plane.
STRUCTURAL SANDWICH	A layered construction comprising a combination or relatively high-strength facing material intimately bonded to and acting integrally with a low density core material.
STRUCTURAL ELEMENT	The component timber members and joints which make up a resulting structural assembly.
STRUCTURAL GRADES	Grades defining the maximum size of strength reducing natural characteristics (knots, sloping grain, etc.) deemed permissible in any piece of structural timber within designated structural grade classification.
STRUCTURAL TIMBER	Timber in which strength is related to the anticipated in-service use as a controlling factor in grading and selection and/or stiffness.

TEMPORARY STRUCTURE	Structures which are erected for a short period, such as hutments at project sites, for rehabilitation, temporary defence constructions, exhibition structures, etc.
TERMITE	An insect of the order Isopteran which may burrow in the wood or wood products of a building for food or shelter.
ULTIMATE STRESS	The stress which is determined on small clear specimen of timber, in accordance with good practice; and does not take into account the effect of naturally occurring characteristics and other factors. Also known as Fundamental Stress
WET LOCATION	Position in buildings in which timbers are almost continuously damp or wet in contact with the earth or water, such as piles and timber foundations.

11.2.3 Definitions Related to Defects in Timber

CHECK	A separation of fibres extending along the grain which is confined to one face of a piece of wood.
COMPRESSION WOOD	Abnormal wood which is formed on the lower sides of branches and inclined stems of coniferous trees. It is darker and harder than normal wood but relatively low in strength for its weight. It can be usually identified by wide eccentric growth rings with abnormally high proportion of growth latewood.
DEAD KNOT	A knot in which the layers of annual growth are not completely inter-grown with those of the adjacent wood. It is surrounded by pitch or bark. The encasement may be partial or complete.
DECAYED KNOT	A knot softer than the surrounding wood and containing decay.
DIAMETER OF KNOT	The maximum distance between the two points farthest apart on the periphery of a round knot, on the face on which it becomes visible. In the case of a spike or a splay knot, the maximum width of the knot visible on the face on which it appears shall be taken as its diameter.
DISCOLORATION	A change from the normal colour of the wood which does not impair the strength of the wood.
KNOT	A branch base or limb embedded in the tree or timber by natural growth.
KNOT HOLE	A hole left as a result of the removal of a knot.
LIVE KNOT	A knot free from decay and other defects, in which the fibres are firmly intergrown with those of the surrounding wood. Syn. 'Intergrown knot'; <i>cf.</i> 'Dead Knot'.

LOOSE GRAIN	A defect on a 6 flat sawn surface caused by the separation or raising of wood fibres along the growth rings; also known as Loosened Grain. <i>cf</i> 'Raised Grain'.
LOOSE KNOT	A knot that is not held firmly in place by growth or position, and that cannot be relied upon to remain in place; <i>cf</i> 'Tight Knot'.
MOULD	A soft vegetative growth that forms on wood in damp, stagnant atmosphere. It is the least harmful type of fungus, usually confined to the surface of the wood.
PITCH POCKET	Accumulation of resin between growth rings of coniferous wood as seen on the cross section
ROT	Disintegration of wood tissue caused by fungi (wood destroying) or other microorganisms. Also known as Decay.
SAP STAIN	Discoloration of the sapwood mainly due to fungi.
SAPWOOD	The outer layer of log, which in the growing tree contain living cells and food material. The sapwood is usually lighter in colour and is readily attacked by insects and fungi.
SHAKE	A partial or complete separation between adjoining layers of tissues as seen in end surfaces.
SLOPE OF GRAIN	The inclination of the fibres to the longitudinal axis of the member.
SOUND KNOT	A tight knot free from decay, which is solid across its face, and at least as hard as the surrounding wood.
SPLIT	A crack extending from one face of a piece of wood to another and running along the grain of the piece.
TIGHT KNOT	A knot so held by growth or position as to remain firm in position in the piece of wood; <i>cf</i> 'Loose Knot'.
WANE	The original rounded surface of a tree remaining on a piece of converted timber.
WARP	A deviation in sawn timber from a true plane surface or distortion due to stresses causing departure from a true plane.
WORM HOLES	Cavities caused by worms.

11.3 Symbols

11.3.1 For the purpose of this Section, the following symbols shall have the meaning indicated against each:

B	=	Width of the beam, mm
C	=	Concentrated load, N
D	=	Depth of beam, mm
D_1	=	Depth of beam at the notch, mm
D_2	=	Depth of notch, mm
E	=	Modulus of elasticity in bending, N/mm ²
F	=	Load acting on a bolt at an angle to grain, N
H	=	Horizontal shear stress, N/mm ²
I	=	Moment of inertia of a section, mm ⁴
K	=	Coefficient in deflection depending upon type and criticality of loading on beam
K_1	=	Modification factor for change in slope of grain
K_2	=	Modification factor for change in duration of loadings
$K_3,$ $K_4,$ $K_5,$ <i>and</i> K_6	=	Form factors
K_7	=	Modification factor for bearing stress
K_8	=	Constant equal to $0.584 \sqrt{\frac{E}{f_{cp}}}$

K_9	=	Constant equal to $\frac{\pi}{2} \sqrt{\frac{UE}{5qf_{cp}}}$
K_{10}	=	Constant equal to $0.584 \sqrt{\frac{2.5E}{f_{cp}}}$
L	=	Span of a beam or truss, mm
M	=	Maximum bending moment in beam N/mm ²
N	=	Total number of bolts in the joint
P	=	Load on bolt parallel to grain, N
P_1	=	Ratio of the thickness of the compression flange to the depth of the beam
Q	=	Moment of area about neutral axis, mm ³
R	=	Load on bolt perpendicular (normal) to grain, N
S	=	Unsupported overall length of column, mm
U	=	Constant for a particular thickness of the plank
V	=	Vertical end reaction or shear at a section, N
W	=	Total uniform load, N
Z	=	Section modulus of beam, mm ³
A	=	Projected area of bolt in main member ($t' X d_3$), mm ²
D	=	Dimension of least side of column, mm
d_1	=	Least overall width of box column, mm
d_2	=	Least overall dimension of core in box column, mm
d_3	=	Diameter of bolt, mm
d_f	=	Bolt-diameter factor

e	=	Length of the notch measured along the beam span from the inner edge of the support to the farthest edge of the notch, mm
f_{ab}	=	Calculated bending stress in extreme fibre, N/mm ²
f_{ac}	=	Calculated average axial compressive stress, N/mm ²
f_{at}	=	Calculated axial tensile stress, N/mm ²
f_b	=	Permissible bending stress on the extreme fibre, N/mm ²
f_c	=	Permissible stress in axial compression, N/mm ²
f_{cn}	=	Permissible stress in compression normal (perpendicular) to grain, N/mm ²
f_{cp}	=	Permissible stress in compression parallel to grain, N/mm ²
f_c^θ	=	Permissible compressive stress in the direction of the line of action of the load, N/mm ²
f_t	=	Permissible stress in tension parallel to grain, N/mm ²
n	=	Shank diameter of the nail, mm
q	=	Constant for particular thickness of plank
q_1	=	Ratio of the total thickness of web or webs to the overall width of the beam
t	=	Nominal thickness of planks used in forming box type column, mm
t'	=	Thickness of main member, mm
x	=	Distance from reaction to load, mm
γ	=	A factor determining the value of form factor K_4
δ	=	Deflection at middle of beam, mm
θ	=	Angle of load to grain direction
λ_1	=	Percentage factor for t'/d_3 ratio, parallel to grain
λ_2	=	Percentage factor for t'/d_3 ratio, perpendicular to grain

11.4 Materials

11.4.1 Species of Timber

For construction purposes, species of timber are classified in three groups on the basis of their strength properties, namely, modulus of elasticity (E) and extreme fibre stress in bending and tension (f_b). The species of timber for structural purposes and their properties are given in Table 6.11.1.

Table 6.11.1: Safe Permissible Stresses for the Species of Timber

Species		Average Density at 12% Moisture Content, Kg/m ³	Modulus of Elasticity $\times 10^3$ N/mm ²	Permissible Stress in N/mm ² for Grade I												Preservative Characters		
Botanical Name	Trade Name			Bending and Tension Along Grains, Extreme Fibre Stress			Shear all Location		Compression Parallel to Grain			Compression Perpendicular to Grain			Durability Class	Treatability Grade	Refracteriness to All	
				Inside Location	outside Location	wet Location	Horizontal	Along Grain	Inside Location	outside Location	wet Location	Inside Location	outside Location	wet Location				
1	2	3	4	5	6	7	8	9	10	11	12	13	14	15	16	17	18	
<i>Acacia nilotica</i>	Babla	797	-	-	12.9	10.3	1.4	2.1	8.9	7.9	6.4	5.2	4.0	3.3	I	b	B	
<i>Aglaia odulis</i>	Aglaia	815	12.56	18.2	15.2	12.1	1.4	2.0	10.1	8.9	7.3	4.4	3.4	2.8	-	-	A	
<i>Ailantahus grandis</i>	Gokul	404	7.94	8.3	6.9	5.5	0.6	0.8	5.3	4.7	3.9	1.1	0.9	0.7	III	-	C	
<i>Altingia excelsa</i>	Jutili	795	11.37	17.1	14.3	11.4	1.2	1.8	11.0	9.8	8.0	6.8	5.3	4.4	II	e	A	
<i>Amoora rehituka</i>	Pitraj	668	8.98	12.3	10.2	8.2	1.1	1.5	8.0	7.1	5.8	4.0	3.1	2.6	I	-	B	
<i>Amoora wallichii</i>	Lali	583	-	-	-	-	-	-	-	-	-	-	-	-	-	-	-	
<i>Amoora spp.</i>	Arnari	625	1.05	13.4	1.1	9.2	0.9	1.3	8.4	7.4	6.0	3.7	2.9	2.4	II	d	B	
<i>Anisoplera glabra</i>	Boilam	573	-	-	-	-	-	-	-	-	-	-	-	-	III	b	-	
<i>Aphenamixis polystachya</i>	Pitraj	583	-	-	-	-	-	-	-	-	-	-	-	-	III	e	B	
<i>Arlocarpus chaplasha</i>	Chapalish	515	9.11	13.2	11.0	8.8	0.9	1.2	8.5	7.5	6.2	3.6	2.8	2.3	III	d	B	
<i>Artocarpus integrifolia</i>	Kanthal	537	-	-	-	-	-	-	-	-	-	-	-	-	III	c	B	
<i>Azadirachta indica</i>	Neem	836	8.52	14.6	12.1	9.7	1.3	1.8	10.0	8.9	7.3	5.0	3.9	3.2	-	-	-	
<i>Betula Inoides</i>	Birch	625	9.23	9.6	8.0	6.4	0.8	1.1	5.7	5.0	4.1	2.2	1.7	1.4	-	-	B	
<i>Bischofia javanica</i>	Bhadi	769	8.84	9.6	8.2	6.5	0.8	1.1	5.9	5.3	4.3	3.6	2.8	2.3	III	-	A	
<i>Bruguiera conjugata</i>	Kankra	879	-	-	-	-	-	-	-	-	-	-	-	-	-	-	A	
<i>Bucklandia populnea</i>	Plpli	672	9.89	12.8	10.7	8.6	1.1	1.5	7.9	7.0	5.7	3.5	2.7	2.2	III	e	C	
<i>Canarium strictum</i>	White dhup	569	10.54	10.1	8.4	6.7	0.7	1.1	6.2	5.5	4.5	2.1	1.6	1.3	III	-	C	
<i>Cassia fistula</i>	Sonalu	865	11.80	19.2	16.0	12.8	1.4	2.0	12.3	10.9	8.9	7.2	5.6	4.6	I	-	A	
<i>Castanopsis hystrix</i>	Chestanut	624	9.85	10.6	8.8	7.0	0.8	1.2	6.4	5.7	4.6	2.7	2.1	1.7	II	b	B	
<i>Carallia lucida</i>	Maniawaga	748	12.60	18.4	15.3	12.3	1.2	1.7	11.4	10.1	8.3	5.9	4.6	3.8	-	-	-	

Species		Average Density at 12% Moisture Content, Kg/m ³	Modulus of Elasticity × 10 ³ N/mm ²	Permissible Stress in N/mm ² for Grade I											Preservative Characters		
Botanical Name	Trade Name			Bending and Tension Along Grains, Extreme Fibre Stress			Shear all Location		Compression Parallel to Grain			Compression Perpendicular to Grain			Durability Class	Treatability Grade	Refractrines to All
				Inside Location	outside Location	wet Location	Horizontal	Along Grain	Inside Location	outside Location	wet Location	Inside Location	outside Location	wet Location			
1	2	3	4	5	6	7	8	9	10	11	12	13	14	15	16	17	18
<i>Cassia siamea</i>	Minjiri	695	-	-	-	-	-	-	-	-	-	-	-	-	-	-	-
<i>Chukrasia tabularis</i>	Chickrassy	666	8.35	11.8	9.8	7.9	1.1	1.5	7.1	6.3	5.2	3.9	3.1	2.5	II	c	B
<i>Dalbergia sissoo</i>	Sissoo	808	-	-	-	-	-	-	-	-	-	-	-	-	-	-	B
<i>Dillenia indica</i>	Dillenia	617	8.61	12.1	10.0	8.0	0.8	1.2	7.3	6.5	5.3	2.7	2.1	1.7	III	a	B
<i>Dillenia pentagyne</i>	Dillenia	622	7.56	11.8	9.9	7.9	0.9	1.3	7.1	6.3	5.2	3.5	2.7	2.2	III	d	B
<i>Dipterocarpus alatus</i>	Garjan	721	-	-	-	-	-	-	-	-	-	-	-	-	III	a	B
<i>Dipterocarpus macrocarpus</i>	Hollong	726	13.34	14.5	12.0	9.6	0.8	1.1	8.8	7.9	6.4	3.5	2.7	2.2	III	a	B
<i>Duabanga sonneratioides</i>	Banderhol	485	8.38	9.8	8.2	6.5	0.6	0.9	6.4	5.7	4.7	1.8	1.4	1.1	III	c	C
<i>Garuga piannata</i>	Garuga	571	7.58	11.7	9.7	7.8	1.0	1.5	7.2	6.4	5.3	3.4	2.6	2.1	I	e	B
<i>Geriops roxbarghiana</i>	Goran	869	-	-	-	-	-	-	-	-	-	-	-	-	-	-	-
<i>Gmelina arborea</i>	Garnar	501	7.02	9.8	8.2	6.6	0.8	1.4	5.7	5.0	4.1	4.2	3.2	2.7	I	e	B
<i>Grewia veslita</i>	Dhaman	758	12.00	15.4	12.6	10.3	1.4	2.0	9.1	8.1	6.6	4.1	3.2	2.6	III	d	B
<i>Heritiera spp.</i>	Sundri	872	13.37	17.9	14.9	11.9	1.3	1.8	11.0	9.8	8.0	6.5	5.0	4.1	I	-	A
<i>Hopea odorata</i>	Telsur	711	-	-	-	-	-	-	-	-	-	-	-	-	III	a	B
<i>Kayea floribund</i>	Karal	813	10.88	16.8	14.0	1.1	1.1	1.6	10.1	9.0	7.3	4.4	3.4	2.8	III	-	-
<i>Lagerstroemia spp.</i>	Jarul	654	-	-	-	-	-	-	-	-	-	-	-	-	III	e	B
<i>Machilus macrantha</i>	Machilus	692	10.00	12.4	10.3	8.3	1.0	1.5	8.2	7.3	6.0	3.5	2.7	2.2	III	e	B/C
<i>Manglietia insignia</i>		449	10.37	10.9	9.1	7.3	0.7	1.4	8.0	7.1	5.8	3.4	2.6	2.1	-	-	-
<i>Manilota polyandra</i>	Ping	903	13.20	19.1	15.9	12.7	1.3	1.8	1.2	10.0	8.5	5.7	4.4	3.6	III	b	A
<i>Mesua assamica</i>	Keyea	842	12.83	17.4	14.5	11.6	1.0	1.4	11.7	10.4	8.5	5.3	4.1	3.3	II	e	-
<i>Mesua ferrea</i>	Mesua	965	16.30	23.3	19.4	15.5	1.2	1.8	15.5	13.8	11.3	5.9	4.6	3.7	I	-	A
<i>Michelia champaca</i>	Champa	644	-	-	-	-	-	-	-	-	-	-	-	-	-	-	B
<i>Michelia montana</i>	Champ	512	8.25	10.9	9.1	7.3	0.7	1.0	6.6	5.9	4.8	2.8	2.2	1.8	I	-	B
<i>Michelia excelsa</i>	Champ	513	10.12	9.8	8.2	6.5	0.7	1.0	6.1	5.5	4.5	1.6	1.3	1.0	II	e	B
<i>Mitragyna pervifolia</i>	Dakroom	651	7.82	12.6	10.5	8.4	1.0	1.5	7.9	7.0	5.7	3.7	2.9	2.4	III	b	B
<i>Palaquium polyanthum</i>	Tali	734	11.24	14.9	12.4	10.0	1.1	1.6	9.9	8.8	7.2	4.7	3.7	3.0	-	-	B
<i>Phoebe hainesiana</i>	Bonsum	566	9.5	13.2	11.0	8.8	0.8	1.2	8.8	7.8	6.4	2.8	2.1	1.8	II	c	B

Species		Average Density at 12% Moisture Content, Kg/m ³	Modulus of Elasticity × 10 ³ N/mm ²	Permissible Stress in N/mm ² for Grade I											Preservative Characters		
Botanical Name	Trade Name			Bending and Tension Along Grains, Extreme Fibre Stress			Shear all Location		Compression Parallel to Grain			Compression Perpendicular to Grain			Durability Class	Treatability Grade	Refracterines to All
				Inside Location	outside Location	wet Location	Horizontal	Along Grain	Inside Location	outside Location	wet Location	Inside Location	outside Location	wet Location			
1	2	3	4	5	6	7	8	9	10	11	12	13	14	15	16	17	18
<i>Phoebe goalperansis</i>	Bonsum	511	7.65	9.7	8.1	6.5	0.7	1.0	6.6	5.9	4.8	2.2	1.7	1.4	II	c	B
<i>Plerygota alata</i>	Narikel	593	10.95	13.4	11.8	8.9	0.8	1.2	8.2	7.3	6.0	2.7	2.1	1.7	III	-	C
<i>Prunus napeulensis</i>	Arupati	548	9.41	4.4	8.7	69.6	0.9	1.2	6.7	6.0	4.9	2.4	1.9	1.6	-	-	-
<i>Pterespermum acerifolium</i>	Hattipaila	607	9.55	13.5	11.3	9.0	0.9	1.2	8.7	7.7	6.3	3.2	2.5	2.0	III	C	B
<i>Quercus lineate</i>	Oak	874	12.63	15.2	12.7	10.1	1.2	1.7	9.6	8.6	7.0	5.3	4.1	3.4	II	c	A
<i>Quercus lamellosa</i>	Oak	87	12.44	14.5	12.1	9.7	1.2	1.7	8.7	7.8	6.4	3.8	2.9	2.4	II	c	A
<i>Schima wallichii</i>	Chilauani	693	9.57	11.1	9.3	7.4	0.9	1.3	6.6	5.9	4.8	2.3	1.8	1.4	III	d	B
<i>Seritiera fomes</i>	Sundri	1073	-	-	-	-	-	-	-	-	-	-	-	-	III	b	B
<i>Shotea assamica</i>	Makai	548	9.27	11.1	9.2	7.4	0.9	1.3	7.1	6.3	5.2	2.9	2.2	1.8	III	c	B
<i>Shorea robusta</i>	Sal	889	-	-	-	-	-	-	-	-	-	-	-	-	III	e	B
<i>Sonneralia apetale</i>	Keora	617	8.63	12.8	10.7	8.5	0.9	1.3	7.4	6.6	5.4	4.8	3.7	3.0	II	-	B
<i>Swintonia floribunda</i>	Civit	665	-	-	-	-	-	-	-	-	-	-	-	-	III	a	C
<i>Syzygium cumini</i>	Jamun	841	10.55	14.8	12.4	9.9	1.1	1.6	9.0	8.0	6.5	6.9	5.4	4.4	II	e	A
<i>Syzygium spp.</i>	Jam	823	-	-	-	-	-	-	-	-	-	-	-	-	III	e	A
<i>Taxus buccata</i>	Yew	705	7.79	14.3	11.9	9.5	1.2	1.7	8.7	7.8	6.4	4.7	3.7	3.0	-	-	-
<i>Tectona grandis</i>	Teak	660	9.97	15.5	12.9	10.3	1.2	1.6	9.4	8.3	6.8	4.5	3.5	2.8	I	e	B
<i>Toena ciliata</i>	Toon	487	6.40	8.7	7.3	5.8	0.7	1.0	5.4	4.8	3.9	2.4	1.8	1.5	II	c	B
<i>Terminalia citra</i>		755	11.89	17.1	14.3	11.4	1.1	1.6	10.8	9.6	7.9	5.0	3.9	3.2	-	-	-
<i>Terminalia myriocarpa</i>	Hollock	615	9.62	11.9	9.9	8.0	0.9	1.2	7.6	6.7	5.5	2.9	2.2	1.8	III	a	B
<i>Xylia dolabriformis</i>	Lohakat	1007	-	-	-	-	-	-	-	-	-	-	-	-	-	-	-
<i>Xylocarpus rolloensis</i>	Passur	757	-	-	-	-	-	-	-	-	-	-	-	-	-	-	B
<i>Zanthoxylum budranga</i>	Mulliam	587	10.65	14.7	12.2	9.8	0.9	1.2	9.5	8.4	6.9	3.4	2.6	2.1	I	e	B

† Classification for preservation based on durability tests, etc.

Class I – Average life more than 120 months;

Class II – Average life 60 months or above but less than 120 months; and

Class III – Average life less than 60 months.

‡ Treatability Grades

a – Heartwood easily treatable;

b – Heartwood treatable, but complete penetration not always obtained; in case where least dimension is more than 60 mm;

c – Heartwood only partially treatable;

d – Heartwood refractory to treatment; and

e – Heartwood very refractory to treatment, penetration of preservative being practically nil even from the ends.

Data based on strength properties at three years of age of tree.

§ Classifications based on seasoning behavior of timber and refractoriness w.r.t. cracking, splitting and drying rate.

A – Highly refractory (slow and difficulty to season free from surface and end cracking);

B – Moderately refractory (may be seasoned free from surface and end cracking within reasonably short periods, given a little protection against rapid drying conditions); and

C – Non-refractory (may be rapidly seasoned free from surface and end-cracking even in the open air and sun. If not rapidly dried, they develop blue stain and mould on the surface.

Grouping of Timber

Characteristics of the three groups of species of timber are given below:

Group A: E above 12.6×10^3 N/mm² and f_b above 18.0 N/mm².

Group B: E above 9.8×10^3 N/mm² and upto 12.6×10^3 N/mm² and f_b above 12.0 N/mm² and upto 18.0 N/mm².

Group C: E above 5.6×10^3 N/mm² and upto 9.8×10^3 N/mm² and f_b above 8.5 N/mm² and upto 12.0 N/mm².

Modulus of elasticity given above is applicable for all locations and extreme fibre stress in bending is for inside location.

11.4.2 The general characteristics like durability and treat ability of the species are also given in Table 6.11.1. Species of timber other than those recommended in Table 6.11.1 may be used, provided the basic strength properties are determined and found in accordance with Sec 11.5.1.

11.4.3 The permissible lateral strength (in double shear) of mild steel wire shall be as given in Table 6.11.2 and Table 6.11.3 for different species of timber.

11.4.4 Moisture Content in Timber The permissible moisture content of timber for various positions in buildings shall be as given in Table 6.11.4.

Tolerances

Permissible tolerances in measurements of cut sizes of structural timber shall be as follows:

- (a) For width and thickness:
- (i) Upto and including 100 mm: +3 to 0 mm
 - (ii) Above 100 mm: +6 to -3 mm
- (b) For length: +10 to 0 mm

11.4.5 Grading of Structural Timber

Cut sizes of structural timber shall be graded, after seasoning, into three grades namely (a) Select Grade, (b) Grade I and (c) Grade II, based on permissible defects given in Table 6.11.8.

11.4.6 Sawn Timber

11.4.6.1 Sizes: Preferred cut sizes of timber for use in structural components shall be as given in Tables 6.11.5 to 6.11.7.

11.4.6.2 The prohibited defects given in Sec 11.4.6.2.1 and permissible defects given in Sec 11.4.6.2.2 shall apply to structural timber.

11.4.6.2.1 Prohibited defects

Loose grains, splits, compression wood in coniferous species, heartwood rot, sap rot, crookedness, worm holes made by powder post beetles and pitch pockets shall not be permitted in all the three grades.

11.4.6.2.2 Defects to the extent specified in Table 6.11.8 shall be permissible.

Wanes are permitted provided they are not combined with knots and the reduction in strength on account of the wanes is not more than the reduction with maximum allowable knots.

11.4.6.3 Location of defects

The influence of defects in timber is different for different locations in the structural element. Therefore, these should be placed during construction in such a way so that they do not have any adverse effect on the members.

Table 6.11.2: Permissible Lateral Strengths (in Double Shear) of Nails 3.55 mm Diameter, 80 mm Long

Species of Wood		For Permanent Construction Strength per Nail		For Temporary Structures Strength per Nail (for Both Lengthening Joints and Node Joints) Nx10 ²
Botanical Name	Trade name	Lengthening Joints, Nx10 ²	Node Joints Nx10 ²	
<i>Acacia nilotica</i>	Babla	15	11	34
<i>Aphenamixis polystachya</i>	Pitraj	19	9	19
<i>Canarium strictum</i>	White dhup	9	8	10.5
<i>Castanopsis hystrix</i>	Chestanut	18	10.5	23.5
<i>Chukrasia tabularis</i>	Chickrassy	24	8	27
<i>Dillenia pentagyne</i>	Dillenia	16.5	12	16
<i>Dipterocarpus macrocarpus</i>	Hollong	17	7	20
<i>Grewia veslita</i>	Dhaman	13	5	24
<i>Hopea odorata</i>	Telsur	31.5	13	28.5
<i>Lagerstroemia spp.</i>	Jarul	24.5	21.5	22.5
<i>Maniltoa polyandra</i>	Ping	26	23.5	32
<i>Mesua ferrea</i>	Mesua	26	8	41
<i>Michelia excelsa</i>	Champ	13	9	20
<i>Phoebe hainesiana</i>	Bonsum	12	6	13
<i>Shorea robusta</i>	Sal	23	15.5	19.5
<i>Syzygium spp.</i>	Jam	15	12	25
<i>Tectona grandis</i>	Teak	14	8	13
<i>Terminalia myriocarpa</i>	Hollock	13	10	19
<i>Toona ciliata</i>	Toon	16	9	21

Note: Nails of 3.55 mm diameter are most commonly used. The above values can also be used for 4 mm diameter 100 mm long nails.

Table 6.11.3: Permissible Lateral Strengths (in Double Shear) of Nails 5.00 mm Diameter, 125 mm and 150 mm Long

Species of Wood		For Permanent Construction Strength per Nail		For Temporary Structures Strength per Nail (for Both Lengthening Joints and Node Joints) Nx10 ²
Botanical Name	Trade name	Lengthening Joints, Nx10 ²	Node Joints Nx10 ²	
<i>Acacia nilotica</i>	Babla	27	13.5	53
<i>Dalbergia sissoo</i>	Sissoo	17	15	43
<i>Mesua ferrea</i>	Mesua	24	15.5	57.5
<i>Michelia excelsa</i>	Champ	26	12.5	39
<i>Phoebe hainesiana</i>	Bonsum	20	7.5	30
<i>Shorea robusta</i>	Sal	19.5	17	37
<i>Syzygium spp.</i>	Jam	18	14.5	38.5
<i>Tectona grandis</i>	Teak	28	13	30
<i>Terminalia myriocarpa</i>	Hollock	27.5	9	41

Table 6.11.4: Permissible Percentage Moisture Content Values

Usage	Permissible Moisture Content
Structural elements	17%
Doors and windows:	
50 mm and above in thickness	14%
Thinner than 50 mm	12%
Flooring strips for general purposes	10%

Table 6.11.5: Preferred Cut Sizes of Structural Timbers for Roof Trusses (Span: 3 m to 20 m)

Thickness (mm)	Width (mm)							
	40	50	60	80	100	120	160	180
20	40	50	60	80	100	-	-	-
25	40	50	60	80	100	120	160	180
30	40	50	60	80	100	120	160	180
35	-	-	60	80	100	120	160	180
40	-	-	60	80	100	120	160	180

Thickness (mm)	Width (mm)							
50	-	-	60	80	100	120	160	180
60	-	-	-	80	100	120	160	180
80	-	-	-	-	100	120	160	180

Notes:

1. For truss spans marginally above 20 m, preferred cut sizes of structural timber may be allowed.

2 Preferred lengths of timber 1, 1.5, 2, 2.5 and 3 m.

Table 6.11.6: Preferred Cut Sizes of Structural Timber for Roof Purlins, Rafters, Floor Beams and other Elements

Thickness (mm)	Width (mm)							
50	80	100	120	140	-	-	-	-
60	80	100	120	140	160	-	-	-
80	-	100	120	140	160	-	-	-
100	-	-	-	140	160	180	200	-

Note: Preferred lengths of timber: 1.5, 2, 2.5 and 3 m.

Table 6.11.7: Preferred Cut Sizes of Structural Timbers for Partition Framing and Covering, and for Centering

Thickness (mm)	Width (mm)								
10	40	50	60	80	-	-	-	-	-
15	40	50	60	80	100	-	-	-	-
20	40	50	60	80	100	120	160	200	-
25	40	50	60	80	100	120	160	200	240
30	40	50	60	80	100	120	160	200	240
40	40	-	60	80	100	120	160	200	240
50	-	50	-	80	100	120	160	200	240
60	-	-	60	80	100	120	160	200	240
80	-	-	-	80	100	120	160	200	240

11.4.7 Suitability

11.4.7.1 Suitability in respect of durability and treatability for permanent structures

There are two choices as given in Sections 11.4.7.1.1 and 11.4.7.1.2.

11.4.7.1.1 First choice

The species shall be any one of the following:

- (a) Untreated heartwood of high durability. Heartwood if containing more than 15 percent sap wood, may need chemical treatment for protection;
- (b) Treated heartwood of moderate and low durability and class 'a' and class 'b' treatability;
- (c) Heartwood of moderate durability and class 'c' treatability after pressure impregnation, and
- (d) Sapwood of all classes of durability after thorough treatment with preservative.

11.4.7.1.2 Second choice

The species of timber shall be heartwood of moderate durability and class 'd' treatability.

11.4.7.2 Choice of load bearing temporary structures or semi-structural components at construction site

- (a) Heartwood of low durability and class 'e' treatability; or
- (b) The species whose durability and/or treatability are yet to be established, as listed in Table 6.11.1.

Table 6.11.8: Permissible Defects for Cut Sizes of Timber for Structural Use

Sl. No.	Defects	Select Grade	Grade I	Grade II
1	2	3	4	5
(i)	WANE	Shall be permissible at its deepest portion up to a limit of 1/8 of the width of the surface on which it occurs	Shall be permissible at its deepest portion up to a limit of 1/6 of the width of surface on which it occurs	Shall be permissible at its deepest portion up to a limit of 1/4 of the width of the surface on which it occurs
(ii)	WORM HOLES	Other than those due to powder post beetles are permissible	Other than those due to powder post beetles are permissible	Other than those due to powder post beetles are permissible
(iii)	SLOPE OF GRAIN	Shall not be more than 1 in 20	Shall not be more than 1 in 15	Shall not be more than 1 in 12
(iv)	LIVE KNOTS			

Max. width of Wide Faces of Cut Sizes of Timber	Permissible Maximum Size of Live Knot on		Permissible Maximum Size of Live Knot on		Permissible Maximum Size of Live Knot on	
	Narrow faces and 1/4 of the width face close to edges of cut size of timber	Remaining central half of the width of the wide faces	Narrow faces and 1/4 of the width face close to edges of cut size of timber	Remaining central half of the width of the wide faces	Narrow faces and 1/4 of the width face close to edges of cut size of timber	Remaining central half of the width of the wide faces
1	2	3	4	5	6	7
75	10	10	19	19	29	30
100	13	13	25	25	38	39
150	19	19	38	38	57	57
200	22	25	44	50	66	75
250	25	29	50	57	66	87
300	27	38	54	75	81	114
350	29	41	57	81	87	123
400	32	44	63	87	96	132
450	33	47	66	93	99	141
500	35	50	69	100	105	150
550	36	52	72	103	108	156
600	38	53	75	106	114	159

(v) CHECKS AND SHAKES

Max. width of Face of Timber	Max. Permissible Depth	Max. Permissible Depth	Max. Permissible Depth
1	2	3	4
75	12	25	36
100	18	35	54
150	25	50	75
200	33	65	99
250	40	81	120
300	50	100	150
350	57	115	171
400	66	131	198
450	76	150	225
500	83	165	249
550	90	181	270
600	100	200	300

11.4.8 Fastenings

All structural members shall be framed, anchored, tied and braced to develop the strength and rigidity necessary for the purposes for which they are used.

Allowable stresses or loads on joints and fasteners shall be determined in accordance with recognized principles. Common mechanical fastenings are of bar type such as nails and spikes, wood screws and bolts, and timber connectors including metallic rings or wooden disc-dowels. Chemical fastenings include synthetic adhesives for structural applications.

11.5 Permissible Stresses

11.5.1 The permissible stresses for Groups A, B and C for different locations applicable to Grade I structural timber shall be as given in Table 6.11.9 provided that the following conditions are satisfied:

- (a) The timbers should be of high or moderate durability and be given the suitable treatment where necessary.
- (b) Timber of low durability shall be used after proper preservative treatment and
- (c) The loads should be continuous and permanent and not of impact type.

11.5.2 The permissible stresses (excepting E) given in Table 6.11.9 shall be multiplied by the following factors to obtain the permissible stresses for other grades provided that the conditions laid down in Sec 11.5.1 are satisfied:

- | | |
|-----------------------------|------|
| (a) For Select Grade Timber | 1.16 |
| (b) For Grade II Timber | 0.84 |

When low durability timbers are to be used [see Sec 11.5.1(b)] on outside locations, the permissible stresses for all grades of timber, arrived at by Sections 11.5.1 and 11.5.2 shall be multiplied by 0.80.

11.5.3 Modification Factors for Permissible Stresses

11.5.3.1 Change in slope of grain

When the timber has not been graded and has major defects like slope of grain, knots and checks or shakes but not beyond permissible value, the permissible stress given in Table 6.11.1 shall be multiplied by modification factor K_1 for different slopes of grain as given in Table 6.11.10.

11.5.3.2 Duration of load

For different durations of design load, the permissible stresses given in Table 6.11.1 shall be multiplied by the modification factor K_2 given in Table 6.11.11.

11.5.3.2.1 The factor K_2 is applicable to modulus of elasticity when used to design timber columns, otherwise they do not apply thereto.

Table 6.11.9: Minimum Permissible Stress Limits (N/mm²) in Three Groups of Structural Timbers (for Grade I Material)

Sl No.	Strength Character	Location of Use	Group A	Group B	Group C
(i)	Bending and tension along grain	Inside ⁽¹⁾	18.0	12.0	8.5
(ii)	Shear ⁽²⁾	All locations	1.05	0.64	0.49
	Horizontal				
	Along grain	All locations	15	0.91	0.70
(iii)	Compression perpendicular to grain	Inside ⁽¹⁾	11.7	7.8	4.9
(iv)	Compression perpendicular to grain	Inside ⁽¹⁾	4.0	2.5	1.1
(v)	Modulus of elasticity ($\times 10^3$ N/mm ²)	All locations and grade	12.6	9.8	5.6

⁽¹⁾ For working stresses for other locations of use, that is, outside and wet, generally factors of 5/6 and 2/3 are applied.

⁽²⁾ The values of horizontal shear to be used only for beams. In all other cases shear along grain to be used.

Table 6.11.10: Modifications Factor K_I to Allow for Change in Slope of Grain

Slope	Modification Factor K_I	
	Strength of Beams, Joists and Ties	Strength of Posts or Columns
1 in 10	0.80	0.74
1 in 12	0.90	0.82
1 in 14	0.98	0.8
1 in 15 and flatter	1.00	1.00

Note: For intermediary slopes of grains, values of modification factor may be obtained by interpolation.

Table 6.11.11: Modifications Factor K_2 , for Change in Duration of Loading

Duration of Loading	Modification Factor K_2
Continuous (Normal)	1.0
Two months	1.15
Seven days	1.25
Wind and earthquake	1.33
Instantaneous or impact	2.00

Note: The strength properties of timber under load are time dependent.

11.5.3.2.2 If there are several duration of loads (in addition to the continuous) to be considered, the modification factor shall be based on the shortest duration load in the combination, that is, the one yielding the largest increase in the permissible stresses, provided the designed section is found adequate for a combination of other larger duration loads.

Explanation: In any structural timber design for dead loads, snow loads and wind or earthquake forces, members may be designed on the basis of total of stresses due to dead, snow and wind loads using $K_2 = 1.33$, factor for the permissible stress (of Table 6.11.1) to accommodate the wind load, that is, the shortest of duration and giving the largest increase in the permissible stresses. The section thus found is checked to meet the requirements based on dead loads alone with modification $K_2 = 1.00$.

11.5.3.2.3 Modification factor K_2 shall also be applied to allowable loads for mechanical fasteners in design of joints, when the wood and not the strength of metal determine the load capacity.

11.6 Design Considerations

11.6.1 All structural members, assemblies or framework in a building, in combination with the floors, walls and other structural parts of the building shall be capable of sustaining, with due stability and stiffness the whole dead and imposed loadings as per Chapters 1 and 2 of Part 6, without exceeding the limits of relevant stresses specified in this Section.

11.6.2 Buildings shall be designed for all dead and imposed loads or forces assumed to come upon them during construction or use, including uplifts or horizontal forces from wind and forces from earthquakes or other loadings. Structural members and their

11.6.3 connections shall be proportioned to provide a sound and stable structure with adequate strength and stiffness. Wooden components in construction generally include panels for sheathing and diaphragms, siding, beams, girder, columns, light framings, masonry wall and joist construction, heavy-frames, glued laminated structural members, structural sandwiches, prefabricated panels, lamella arches, portal frames and other auxiliary constructions.

11.6.4 Net Section

11.6.4.1 The net section is obtained by deducting from the gross sectional area of timber the projected area of all material removed by boring, grooving or other means at critical plane. In case of nailing, the area of the prebored hole shall not be taken into account for this purpose.

11.6.4.2 The net section used in calculating load carrying capacity of a member shall be at least net section determined as above by passing a plane or a series of connected planes transversely through the members.

11.6.4.3 Notches shall be in no case remove more than one quarter of the section.

11.6.4.4 In the design of an intermediate or a long column, gross section shall be used in calculating load carrying capacity of the column.

11.6.5 Loads

11.6.5.1 The loads shall conform to those given in Chapter 2 Part 6 of this Code.

11.6.5.2 The worst combination and location of loads shall be considered for design. Wind and seismic forces shall not be considered to act simultaneously.

11.6.6 Flexural Members

11.6.6.1 Such structural members shall be investigated for the following:

- (a) Bending strength,
- (b) Maximum horizontal shear,
- (c) Stress at the bearings, and
- (d) Deflection.

11.6.6.2 Effective span

The effective span of beams and other flexural members shall be taken as the distance from face of supports plus one-half of the required length of bearing at each end except that for continuous beams and joists the span may be measured from centre of bearing at those supports over which the beam is continuous.

11.6.6.3 Usual formula for flexural strength shall apply in design:

$$f_{ab} \frac{M}{z} \leq f_b \quad (6.11.1)$$

11.6.6.4 Form factors for flexural members

The following form factors shall be applied to the bending stress:

- (a) Rectangular Section - For rectangular sections, for different depths of beams, the form factor K_3 shall be taken as:

$$K_3 = 0.81 \left(\frac{D^2 + 89400}{D^2 + 55000} \right) \quad (6.11.2)$$

Form factor (K_3) shall not be applied for beams having depth less than or equal to 300 mm.

- (b) Box Beams and I-Beams - For box beams and I-beams, the form factor K_4 obtained by using the formula:

$$K_4 = 0.8 + 0.8y \left(\frac{D^2 + 89400 - 1}{D^2 + 55000} \right) \quad (6.11.3)$$

Where,

$$y = p_1^2 + (6 - 8p_1 + 3p_1^2)(1 - q_1) + q_1 \quad (6.11.4)$$

- (c) Solid Circular Cross-Sections - For solid circular cross sections the form factor K_5 shall be taken as 1.18.
- (d) Square Cross-Sections - For square cross-sections where the load is in the direction of diagonal, the form factor K_6 shall be taken as 1.414.

11.6.6.5 Width

The minimum width of the beam or any flexural member shall not be less than 50 mm or 1/50 of the span, whichever is greater.

11.6.6.6 Depth

The depth of beam or any flexural member shall not be taken more than three times of its width without lateral stiffening.

11.6.6.6.1 Stiffening

All flexural members having a depth exceeding three times its width or a span exceeding 50 times its width or both shall be laterally restrained from twisting or buckling and the distance between such restraints shall not exceed 50 times its width.

11.6.6.7 Shear

11.6.6.7.1 The following formulae shall apply:

- (a) The maximum horizontal shear, when the load on a beam moves from the support towards the centre of the span, and the load is at a distance of three to four times the depth of the beam from the support, shall be calculated from the following general formula:

$$H = \frac{VQ}{Ib} \quad (6.11.5a)$$

- (b) For rectangular beams:

$$H = \frac{3V}{2bD} \quad (6.11.5b)$$

- (c) For notched beams, with tension notch at supports (Figure 6.11.1a):

$$H = \frac{3VD}{2bD_1^2} \quad (6.11.5c)$$

- (d) For notched at upper (compression) face, where $e > D$ (Figure 6.11.1b):

$$H = \frac{3V}{2bD_1} \quad (6.11.5d)$$

- (e) For notched at upper (compression) face, where $e < D$ (Figure 6.11.1b)

$$H = \frac{3V}{2b\left[D - \left(\frac{D_2}{D}\right)e\right]} \quad (6.11.5e)$$

11.6.6.7.2 For concentrated loads:

$$V = \frac{10C(l-x)(x/D)^2}{9I[2+(x/D)^2]} \quad (6.11.6a)$$

and, for uniformly distributed loads,

$$V = \frac{w}{2} \left(1 - \frac{2D}{l} \right) \quad (6.11.6b)$$

After arriving at the value of V, its value will be substituted in the formula:

$$H = \frac{VQ}{Ib} \quad (6.11.5a)$$

11.6.6.7.3 In determining the vertical reaction following deductions in loads maybe made:

- (a) Consideration shall be given to the possible distribution of load to adjacent parallel beams, if any;
- (b) All uniformly distributed loads within a distance equal to the depth of the beam from the edge of the nearest support may be neglected except in case of beam hanging downwards from a particular support, and
- (c) All concentrated loads in the vicinity of the supports may be reduced by the reduction factor applicable according to Table 6.11.12.

Table 6.11.12: Reduction Factor for Concentrated Loads in the Vicinity of Supports

Distance of Load from the Nearest Support	LSD or Less	2D	2.5D	3D or More
Reduction factor	0.6	0.4	0.2	No Reduction

Note : For intermediate distances, factor may be obtained by linear interpolation.

11.6.6.7.4 Unless the local stress is calculated and found to be within the permissible stress, flexural member shall not be cut, notched or bored except as follows:

- (a) Notches may be cut in the top or bottom neither deeper than one-fifth of the depth of the beam nor farther from the edge of the support than one-sixth of the span;
- (b) Holes not larger in diameter than one quarter of the depth may be bored in the middle third of the depth and length; and

- (c) If holes or notches occur at a distance greater than three times the depth of the member from the edge of the nearest support, the net remaining depth (Figure 6.11.1c) shall be used in determining the bending strength.

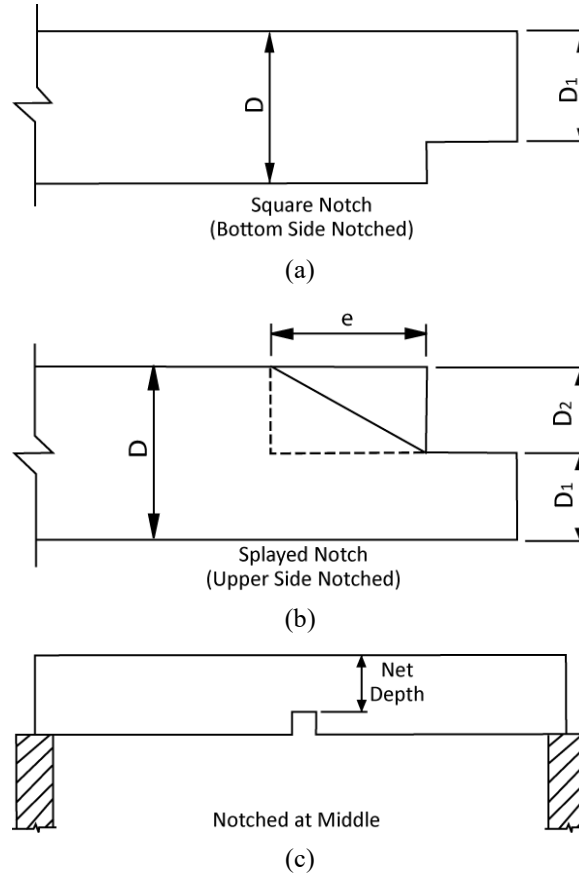


Figure 6.11.1 Notched beams

11.6.6.8 Bearing

11.6.6.8.1 The ends of flexural members shall be supported in recesses which provide adequate ventilation to prevent dry rot and shall not be enclosed. Flexural members except roof timbers that are supported directly on masonry or concrete shall have a length of bearing not less than 75 mm. Members supported on corbels, offsets and roof timbers on a wall shall bear immediately on and be fixed to wall plate not less than 75 mm x 40 mm.

11.6.6.8.2 Timber joists or floor planks shall not be supported on the top flange of steel beams unless the bearing stress, calculated on the net bearing as shaped to fit the beam, is less than the permissible compressive stress perpendicular to the grain.

11.6.6.8.3 Bearing stress

Length and position of bearing

- (a) At any bearing on the side grain of timber, the permissible stress in compression perpendicular to the grain, f_{cn} , is dependent on the length and position of the bearing.
- (b) The permissible stresses given in Table 6.11.1 for compression perpendicular to the grain are also the permissible stresses for any length at the ends of a member and for bearings 150 mm or more in length at any other position.
- (c) For bearings less than 150 mm in length located 75 mm or more from the end of a member as shown in Figure 6.11.2, the permissible stress may be multiplied by the modification factor K_7 given in Table 6.11.13.
- (d) No allowance need be made for the difference in intensity of the bearing stress due to bending of a beam.
- (e) The bearing area should be calculated as the net area after allowance for the amount of wane.
- (f) For bearings stress under a washer or a small plate, the same coefficient specified in Table 6.11.13 may be taken for a bearing with a length equal to the diameter of the washer or the width of the small plate.
- (g) When the direction of stress is at angle to the direction of the grain in any structural member, then the permissible bearing stress in that member shall be calculated by the following formula:

$$f_c^\theta = \frac{f_{cp} \times f_{cn}}{f_{cp} \sin^2 \theta + f_{cn} \cos^2 \theta} \quad (6.11.7)$$

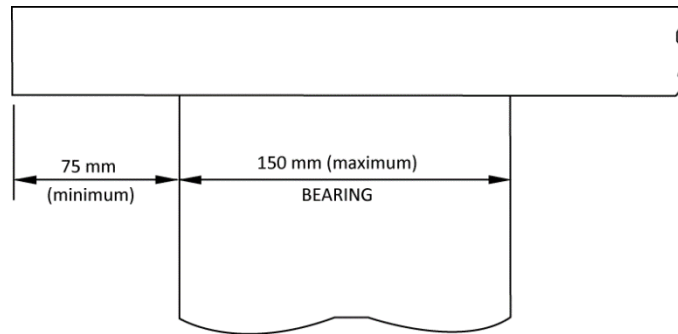


Figure 6.11.2 Position of end bearings

Table 6.11.13: Modification Factor K_7 for Bearing Stresses

Length of bearing in mm	15	25	40	50	75	100	150 or more
Modification factor K_7	1.67	1.40	1.25	1.20	1.13	1.10	1.00

11.6.6.9 Deflection

The deflection in the case of all flexural members supporting brittle materials like gypsum ceilings, slates, tiles and asbestos sheets shall not exceed 1/360 of the span. The deflection in the case of other flexural members shall not exceed 1/240 of the span and 1/150 of the freely hanging length in the case of cantilevers.

11.6.6.9.1 Usual formula for deflection shall apply (ignoring deflection due to shear strain):

$$\delta = \frac{KWL^3}{EI} \quad (6.11.8)$$

K-values = 1/3 for cantilevers with load at free end,

= 1/8 for cantilevers with uniformly distributed load,

= 1/48 for beams supported at both ends with point load at centre, and

= 5/384 for beams supported at both ends with uniformly distributed load.

11.6.6.9.2 In order to allow the effect of long duration loading on E, for checking deflection in case of beams and joists the effective loads shall be twice the dead load if timber is initially dry.

11.6.6.9.3 Self-weight of beam shall be considered in design.

11.6.7 Columns

The formulae given are for columns with pin end conditions and the length shall be modified suitably with other end conditions.

11.6.7.1 Solid columns

Solid columns shall be classified into short, intermediate and long columns depending upon their slenderness ratio S/d as follows:

- (a) Short columns - where S/d does not exceed 11.
- (b) Intermediate columns - where S/d is between 11 and K_g , and
- (c) Long columns - where S/d is greater than K_g .

11.6.7.1.1 For short columns, the permissible compressive stress shall be calculated as follows:

$$f_c = f_{cp} \quad (6.11.9)$$

11.6.7.1.2 For intermediate columns, the permissible compressive stress is calculated by using the following formula:

$$f_c = f_{cp} \left[1 - \frac{1}{3} \left(\frac{S}{K_g d} \right)^4 \right] \quad (6.11.10)$$

11.6.7.1.3 For long columns, the permissible compressive stress shall be calculated by using the following formula:

$$f_c = \frac{0.329E}{(S/d)^2} \quad (6.11.11)$$

11.6.7.1.4 In case of solid columns of timber, S/d ratio shall not exceed 50.

11.6.7.1.5 The permissible load on a column of circular cross-section shall not exceed that permitted for a square column of an equivalent cross-sectional area.

11.6.7.1.6 For determining S/d ratio of a tapered column, its least dimension shall be taken as the sum of the corresponding least dimensions at the small end of the column and one-third of the difference between this least dimension at the small end and the corresponding least dimension at the large end, but in no case shall the least dimension for the column be taken as more than one and a half times the least dimension at the small end. The induced stress at the small end of the tapered column shall not exceed the permissible compressive stress in the direction of grain.

11.6.7.2 Built-up columns

11.6.7.2.1 Box column

Box columns shall be classified into short, intermediate and long columns as follows:

- (a) Short columns - where $\frac{s}{\sqrt{d_1^2+d_2^2}}$ is less than 8;
- (b) Intermediate columns - where $\frac{s}{\sqrt{d_1^2+d_2^2}}$ is between 8 and K_9 ; and
- (c) Long columns - where $\frac{s}{\sqrt{d_1^2+d_2^2}}$ is greater than K_9

11.6.7.2.2 For short columns, the permissible compressive stress shall be calculated as follows:

$$f_c = qf_{cp} \quad (6.11.12)$$

11.6.7.2.3 For intermediate columns, the permissible compressive stress shall be obtained using the following formula

$$f_c = qf_{cp} \left[1 - \frac{1}{3} \left(\frac{s}{\sqrt{d_1^2+d_2^2}} \right)^4 \right] \quad (6.11.13)$$

11.6.7.2.4 For long columns, the permissible compressive stress shall be calculated by using the following formula:

$$f_c = \frac{0.329UE}{\left(\frac{s}{\sqrt{d_1^2+d_2^2}} \right)^2} \quad (6.11.14)$$

11.6.7.2.5 The following values of U and q , depending upon plank thickness (t) in Sections 11.6.6.2.3 and 11.6.6.2.4, shall be used:

t (mm)	U	q
25	0.80	1.00
30	0.60	1.00

11.6.7.3 Spaced columns

11.6.7.3.1 The formulae for solid columns as specified in Sec 11.6.6.1 are applicable to spaced columns with a restraint factor of 2.5 or 3, depending upon distances of end connectors in the column.

A restrained factor of 2.5 for location of centroid group of fasteners at $S/20$ from end and 3 for location at $S/10$ to $S/20$ from end shall be taken.

11.6.7.3.2 For intermediate spaced column, the permissible compressive stress shall be:

$$f_c = f_{cp} \left[1 - \frac{1}{3} \left(\frac{S}{k_{10}d} \right)^4 \right] \quad (6.11.15)$$

11.6.7.3.3 For long spaced columns, the formula shall be:

$$f_c = \frac{0.329E \times 2.5}{(S/d)^2} \quad (6.11.16)$$

11.6.7.3.4 For individual members of spaced columns, S/d ratio shall not exceed 80.

11.6.7.4 Compression members shall not be notched. When it is necessary to pass services through such a member, this shall be effected by means of a bored hole provided that the local stress is calculated and found to be within the permissible stress specified. The distance from the edge of the hole to the edge of the member shall not be less than one quarter of width of the face.

11.6.8 Structural Members Subject to Bending and Axial Stresses

11.6.8.1 Structural members subjected both to bending and axial compression shall be designed to comply with the following formula:

$$\frac{f_{ac}}{f_c} + \frac{f_{ab}}{f_b} \quad (6.11.17)$$

11.6.8.2 Structural members subjected both to bending and axial tension shall be designed to comply with the following formula:

$$\frac{f_{at}}{f_t} + \frac{f_{ab}}{f_b} \quad (6.11.18)$$

11.7 Design of Common Steel Wire Nail Joints

11.7.1 General

Nail jointed timber construction is suitable for light and medium timber framings (trusses, etc) up to 15 m spans. With the facilities of readily available materials and simpler workmanship in mono-chord and split chord constructions, this type of fabrication has a large scope.

11.7.2 Dimensions of Members

11.7.2.1 The dimension of art individual piece of timber (that is, any single member) shall be within the range given below:

- (a) The minimum thickness of the main members in mono-chord construction shall be 30 mm.
- (b) The minimum thickness of an individual piece of members in split-chord construction shall
- (c) The space between two adjacent pieces of timber shall be restricted to a maximum of 3 times the thickness of the individual piece of timber of the chord member. In case of web members, it may be greater for joining facilities.

11.7.3 No lengthening joint shall preferably be located at a panel point. Generally not more than two, but preferably one, lengthening joint shall be permitted between the two panel points of the members.

11.7.4 Specification and Diameter of Nails

11.7.4.1 The nails used for timber joints shall conform to Part 5 'Building Materials'. The nails shall be diamond pointed.

11.7.4.2 The diameter of nail shall be within the limits of one-eleventh to one-sixth of the least thickness of members being connected.

11.7.4.3 Where the nails are exposed to be saline conditions, common wire nails shall be galvanized.

11.7.5 Arrangement of Nails in the Joints

The end distances, edge distances and spacing of nails in a nailed joint should be such as to avoid undue splitting of the wood and shall not be less than those given in Sections 11.7.5.1 and 11.7.5.2.

11.7.5.1 Lengthening joints

The requirement of spacing of nails in a lengthening joint shall be as follows, Table 6.11.14 (see also Figure 6.11.3):

Table 6.11.14: Requirement for Spacing of Nail

Sl. No.	Spacing of Nails	Type of Stress in the Joint	Minimum Requirement
(i)	End distance	Tension	12n
		Compression	10n
(ii)	In direction of grain	Tension	10n
		Compression	5n
(iii)	Edge distance	-	5n
(iv)	Between row of nails perpendicular to the grain	-	5n

Notes:

1.n is shank diameter of nails

2.The 5n distance between the rows of nails perpendicular to the grain may be increased subject to the availability of width of the member keeping edge distance constant.

11.7.5.2 Node joints

The requirement for spacing of nails in node joints shall be as specified in Figure 6.11.4 where the members are at right angle and as in Figure 6.11.5 where the members are inclined to one another at angles other than 90° and subjected to either pure compression or pure tension.

11.7.6 Penetration of Nails

11.7.6.1 For a lap joint when the nails are driven from the side of the thinner member, the length of penetration of nails in the thicker member shall be one and a half times the thickness of the thinner member subject to maximum of the thickness of the thicker member.

11.7.6.2 For butt joints the nails shall be driven through the entire thickness of the joint.

11.7.7 Design Considerations

11.7.7.1 Where a number of nails are used in a joint, the allowable load in lateral resistance shall be the sum of the allowable loads for the individual nails, provided that the centroid of the group of these nails lies on the axis of the member and the spacing conform to Sec 11.7.5. Where a large number of nails are to be provided at a joint, they should be so arranged that there are more of rows rather than more number of nails in a row.

11.7.7.2 Nails shall, as far as practicable, be arranged so that the line of force in a member passes through the centroid of the group of nails. Where this is not practicable, allowance shall be made for any eccentricity in computing the maximum load on the fixing nails as well as the loads and bending moment in the member.

11.7.7.3 Adjacent nails shall preferably be driven from opposite faces, that is, the nails are driven alternatively from either face of joint.

11.7.7.4 For a rigid joint, a minimum of 2 nails for nodal joints and 4 nails for lengthening joint shall be driven.

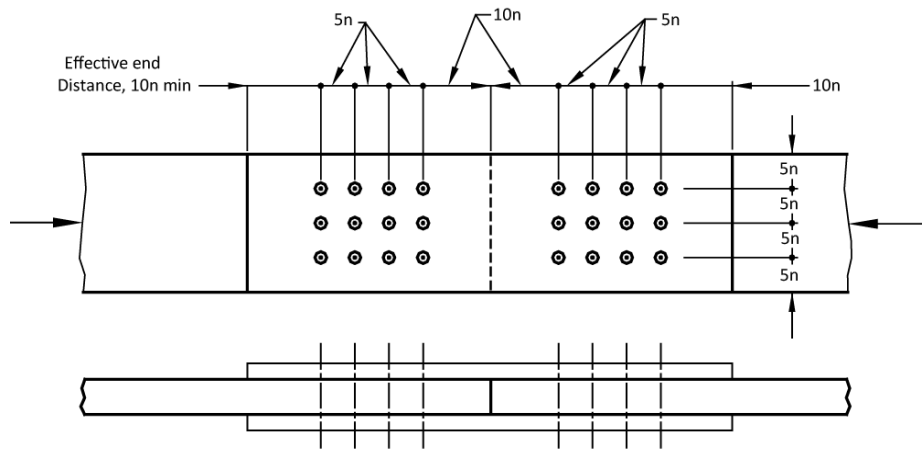
11.7.7.5 Two nails in a horizontal row are better than using the same number of nails in a vertical row.

11.7.8 Special Consideration in Nail-Jointed Truss Construction

11.7.8.1 The initial upward camber provided at the centre of the lower chord of nail-jointed timber trusses shall be not less than 1/200 of the effective span for timber structures using seasoned wood and 1/100 for unseasoned or partially seasoned wood.

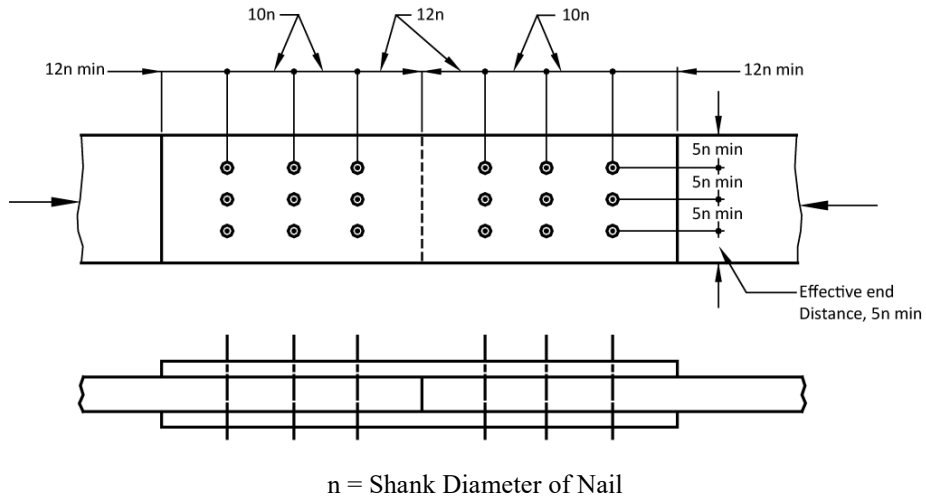
11.7.8.2 The total combined thickness of the gusset or splice plates on either side of the joint in a mono-chord type construction shall not be less than one and a half times the thickness of the main members subject to a minimum thickness of 25 mm of individual gusset plate.

11.7.8.3 The total combined thickness of all spacer blocks or plates or both including outer splice plates, at any joint in a split-chord type construction shall not be less than one and a half times the total thickness of all the main members at that joint.



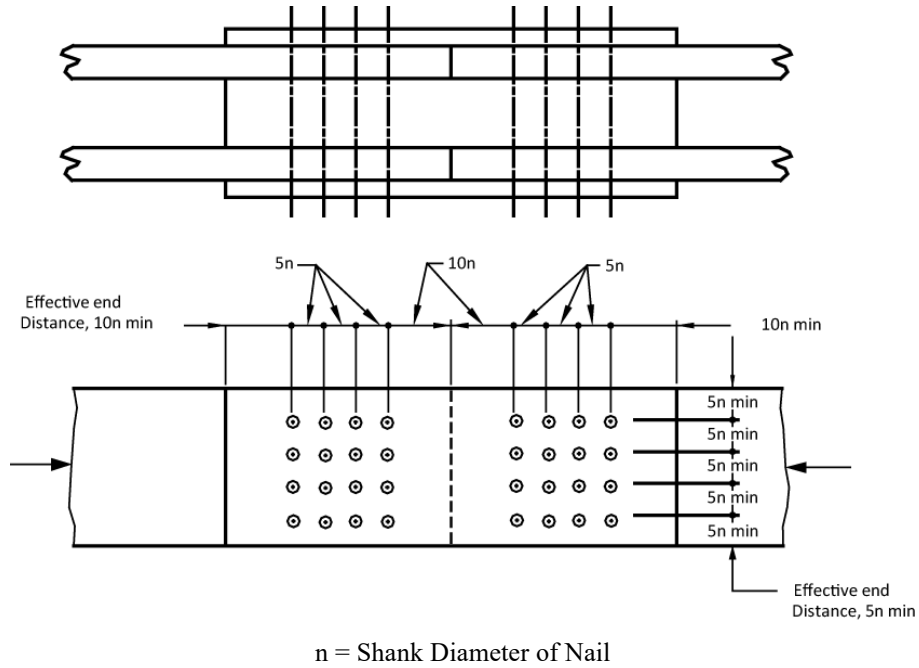
$n = \text{Shank Diameter of Nail}$

(a) Monochord type butt joint subject to compression

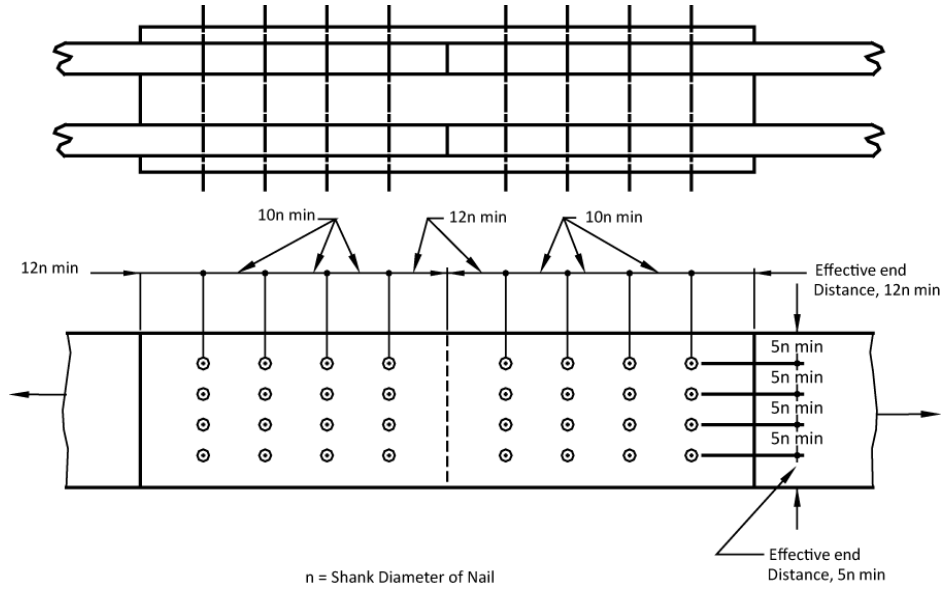


(b) Monochord type butt joint subject to tension

Figure 6.11.3 Spacing of nails In a lengthening joint

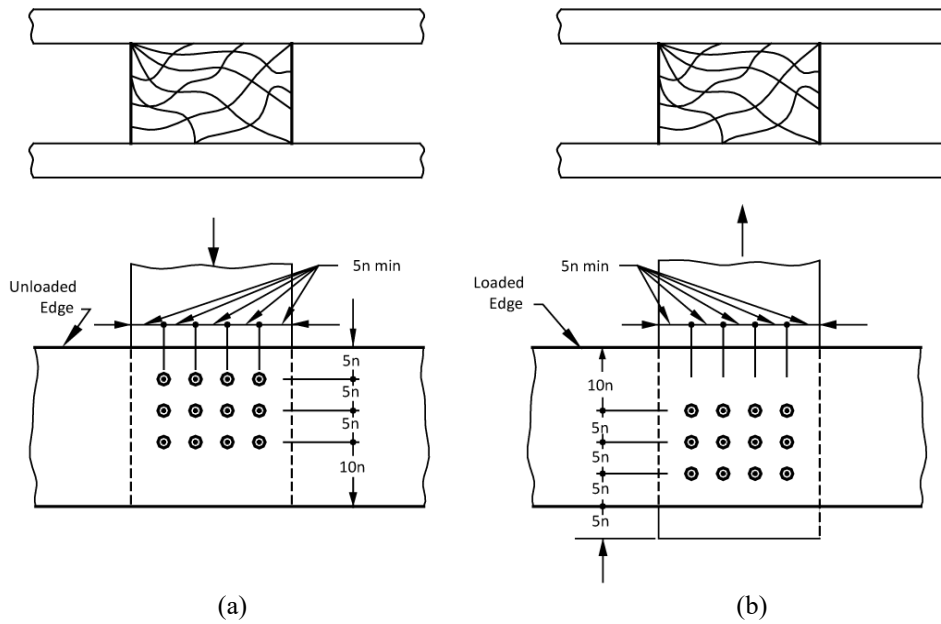


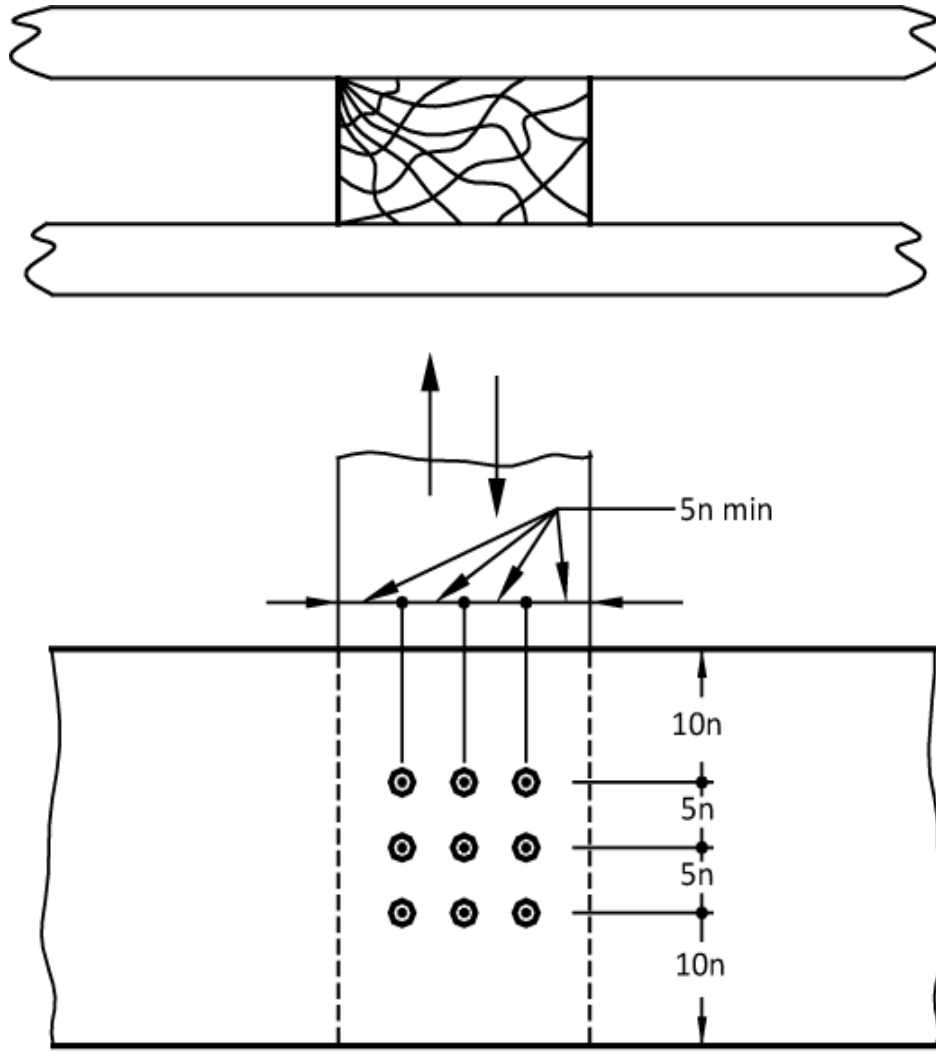
(c) Split-Chord type butt joint subject to compression



(d) Split – Chord type butt joint subject to tension

Figure 6.11.3 Spacing of nails In a lengthening joint (contd.)





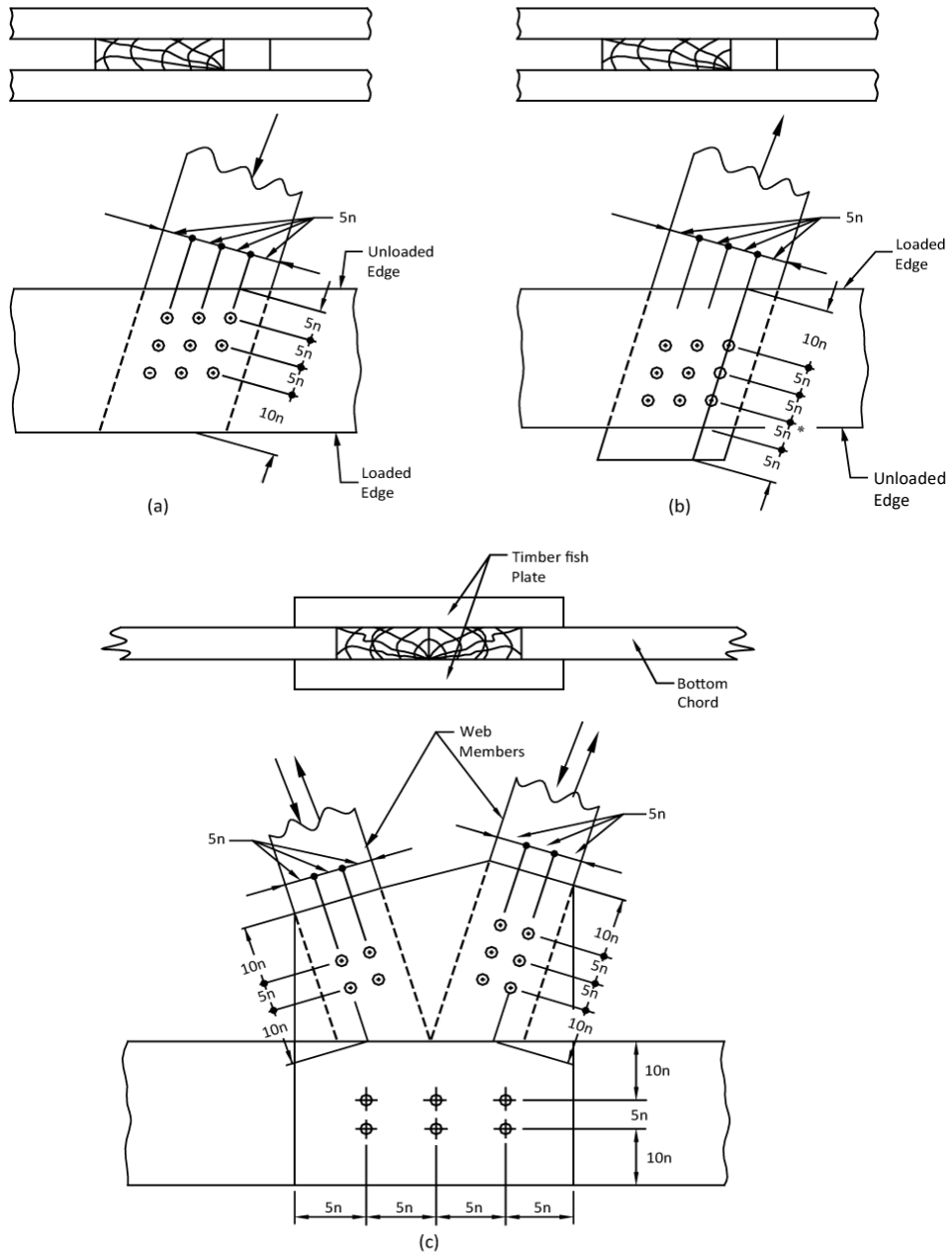
(c)

*5n may be increased to 10n, if the designed width of cord member permits.

Otherwise, the end of the loaded web member may be extended by 5n min

n = Shank diameter of nail

Figure 6.11.4 Spacing of nails where members are at right angles to one another



* $5n$ may be increased to $10n$, if the designed width of cord member permits.
 Otherwise, the end of the loaded web member may be extended by $5n$ min
 n = Shank diameter of nail

Figure 6.11.5 Spacing of nails at node where members are inclined to one another

11.8 DESIGN OF NAIL LAMINATED TIMBER BEAMS

11.8.1 Method of Arrangement

11.8.1.1 The beam is made up of 20 mm to 30 mm thick planks placed vertically with joints staggered in the adjoining planks with a minimum distance of 300 mm. The planks are laminated with the help of wire nails at regular intervals to take up horizontal shear developed in the beam besides keeping the planks in position (see Figure 6.11.6).

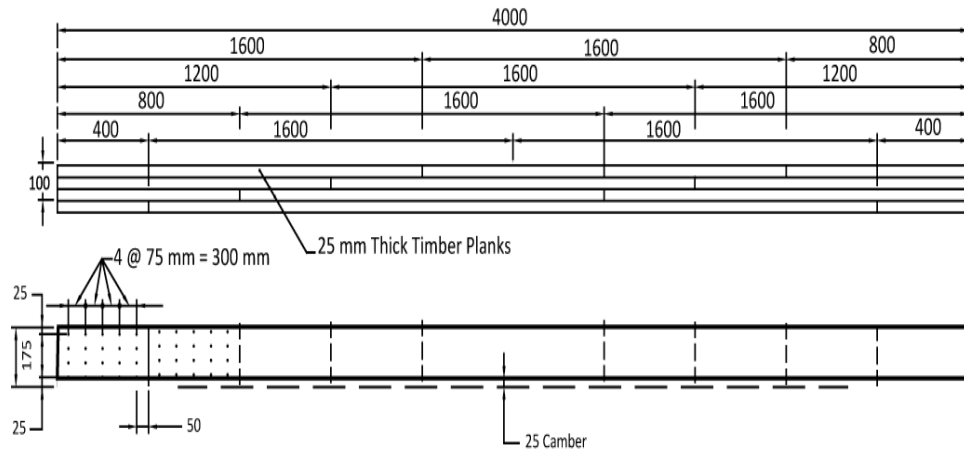
11.8.1.2 The advantage in laminations lies in dimensional stability, dispersal of defects and better structural performance.

11.8.2 Sizes of Planks and Beams

11.8.2.1 The plank thickness for fabrication of nailed laminated beams recommended are 20, 25 and 30 mm.

11.8.2.2 In case of nailed laminated timber beam the maximum depth and length of planks shall be limited to 250 mm and 2000 mm, respectively.

11.8.2.3 In order to obtain the overall width of the beam, the number and thickness of planks to form vertical nailed laminated beams, and also type and size of wire nail shall be as mentioned in Table 6.11.15. The protruding portion of the nail shall be cut off or clenched across the grains.



All dimensions in millimetres.

Figure 6.11.6 Plan and elevation of a typical nailed laminated timber beam (all dimensions in mm)

Table 6.11.15: Number and Size of Planks and Nails for Nailed Laminated Beams

Sl. No.	Overall Width of Beam (mm)	No. of Planks	Thickness of each Plank (mm)	Size of Nail to be used	
				Length (mm)	Diameter (mm)
(i)	50	2	25	80	3.55
(ii)	60	3	20	80	3.55
(iii)	70	3	(2x25) + (1x20)	80	3.55
(iv)	80	4	20	100	4.0
(v)	90	3	30	100	4.0
(vi)	100	4	25	125	5.0
(vii)	110	4	(3x30) + (1x20)	125	5.0
(viii)	120	4	30	125	5.0
(ix)	150	5	30	150	5.0

Notes: A number of combinations of different thickness of planks may be adopted as long as the minimum and maximum thickness of the planks are adhered to.

11.8.3 Design Considerations

11.8.3.1 Nail laminated beams shall be designed in accordance with Sec 11.6.

11.8.3.1.1 The deflection in the case of nailed laminated timber beams, joists, purlins, battens and other flexural members supporting brittle materials like gypsum, ceiling slates, tiles and asbestos sheets shall not exceed 1/480 of the span. The deflection in case of other flexural members shall not exceed 1/360 of the span in the case of beams and joists, and 1/225 of the freely hanging length in case of cantilevers.

11.8.3.2 Permissible lateral strength of mild steel wire nails shall be as given in Tables 6.11.2 and 6.11.3 for Indian Species of timber, which shall apply to nails that have their points cut flush with the faces. For nails clenched across the grains strength may be increased by 20% over the values for nails with points cut flush.

11.8.3.3 Arrangement of nails

11.8.3.3.1 A minimum number of four nails in a vertical row at regular interval not exceeding 75 mm to take up horizontal shear as well as to keep the planks in position shall be used. Near the joints of the planks this distance may, however, be limited to 5 cm instead of 75 mm.

11.8.3.3.2 Shear shall be calculated at various points of the beam and [the number of nails required shall be accommodated within the distance equal to the depth of the beam, with a minimum of 4 nails in a row at a standard spacing as shown in Figure 6.11.7.

11.8.3.3.3 If the depth of the beam is more, then the vertical intermediate spacing of nails may be increased proportionately.

11.8.3.3.4 If the nails required at a point are more than that can be accommodated in a row, then these shall be provided lengthwise of the beam within the distance equal to depth of beam at standard lengthwise spacing.

11.8.3.3.5 For nailed laminated beam minimum depth of 100 mm for 3.55 mm and 4 mm diameter nails, and 125 mm for 5 mm diameter nails shall be provided.

11.9 Design of Bolted Construction Joints

11.9.1 General

Bolted joints suit the requirements of prefabrication in small and medium span timber structures for speed and economy in construction. Bolt jointed construction units offer better facilities as regards to workshop ease, mass production of components, transport convenience and re-assembly at site of work particularly in defence sector for high altitudes and far off situations.

Designing is mainly influenced by the species, size of bolts, moisture conditions and the inclination of loadings to the grains. In principle bolted joints follow the pattern of rivetted joints in steel structures.

11.9.2 Design Considerations

11.9.2.1 Bolted timber construction shall be designed in accordance with 6. The concept of critical section, that is, the net section obtained by deducting the projected area of bolt-holes from the cross-sectional area of member is very important for the successful design and economy in timber.

11.9.2.2 Bolt bearing strength of wood

The allowable load for a bolt in a joint consisting of two members (single shear) shall be taken as one half the allowable loads calculated for a three member joint (double shear) for the same t'/d_3 ratio. The percentage of safe working compressive stress of timber on bolted joints for different t'/d_3 ratios shall be as in Table 6.11.16.

11.9.2.2.1 Where a number of bolts are used in a joint, the allowable loads shall be the sum of the allowable loads for the individual bolts.

11.9.2.2.2 The factors for different bolt diameter used in calculating safe bearing stress perpendicular to grain in the joint shall be as given in Table 6.11.17.

11.9.2.2.3 Dimensions of members

- The minimum thickness of the main member in mono-chord construction shall be 40 mm.
- The minimum thickness of side members shall be 20 mm and shall be half the thickness of main members.
- The minimum individual thickness of spaced member in split-chord construction shall be 20 mm and 25 mm for webs and chord members respectively.

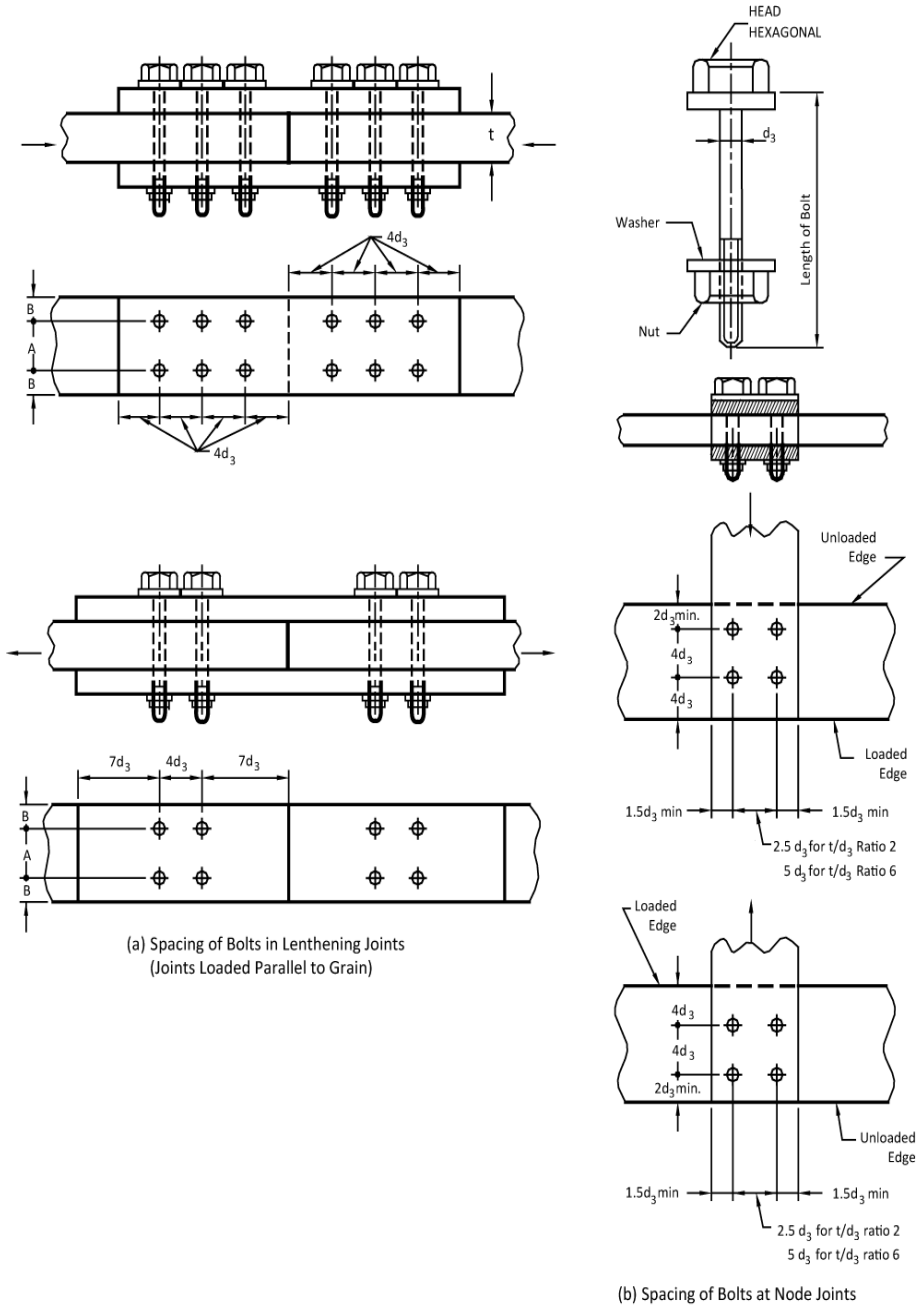


Figure 6.11.7 Typical spacing of bolts in structural joints

Table 6.11.16: Percentage of Safe Working Compressive Stress of Timber for Bolted Joints in Double Shear

t'/d_3 ratio	Stress Percentage		t'/d_3 ratio	Stress Percentage	
	Parallel to Grain	Perpendicular to Grain		Parallel to Grain	Perpendicular to Grain
	λ_1	λ_2		λ_1	λ_2
1.0	100	100	7.0	52	40
1.5	100	96	7.5	46	39
2.0	100	88	8.0	40	38
2.5	100	80	8.5	36	36
3.0	100	72	9.0	34	34
3.5	100	66	9.5	32	33
4.0	96	60	10.0	30	31
4.5	90	56	10.5	-	31
5.0	80	52	11.0	-	30
5.5	72	49	11.5	-	30
6.0	65	46	12.0	-	28
6.5	58	43			

Table 6.11.17: Bolt Diameter Factor

Diameter of Bolt (mm)	Diameter Factor (d_r)	Diameter of Bolt (mm)	Diameter Factor (d_r)
6	5.70	20	3.05
10	3.60	22	3.00
12	3.35	25	2.90
16	3.15		

11.9.2.3 Bolts and bolting

- (a) The diameter of bolt in the main member shall be so chosen to give larger slenderness t'/d_3 ratio of bolt.
- (b) There shall be more number of small diameter bolts rather than small number of large diameter in a joint.
- (c) A minimum of two bolts for nodal joints and four bolts for lengthening joints shall be provided.
- (d) There shall be more number of rows rather than more bolts in a row.
- (e) The bolt holes shall be of such diameter that the bolt can be driven easily.
- (f) Washers shall be used between the head of bolt and wood surface as also between the nut and wood.

11.9.3 Arrangement of Bolts

11.9.3.1 The following spacing in bolted joints shall be followed (see Figure 6.11.8):

- (a) Spacing of Bolts in a Row - For parallel and perpendicular to grain loading = $4d_3$
- (b) Spacing Between Rows of Bolts
 - (i) For perpendicular to grain loading - $2.5d_3$, to $5d_3$ ($2.5d_3$, for t'/d_3 ratio of 2 and $5d_3$ for t'/d_3 ratio of 6 or more. For ratios between 2 to 6 the spacing shall be obtained by interpolation.
 - (ii) For parallel to grain loading - At least $(N-4)d_3$, with a minimum of $2.5d_3$. Also governed by net area at critical section which should be 80 percent of the total area in bearing under all bolts.
- (c) End Distance - $7d_3$ for soft woods in tension, $5d_3$ for hardwoods in tension and $4d_3$ for all species in compression.
- (d) Edge Distance
 - (i) For parallel to grain loading $1.5d_3$ or half the distance between rows of bolts, whichever is greater.

- (ii) For perpendicular to grain loading, (loaded edge distance) shall be at least $4d_3$.

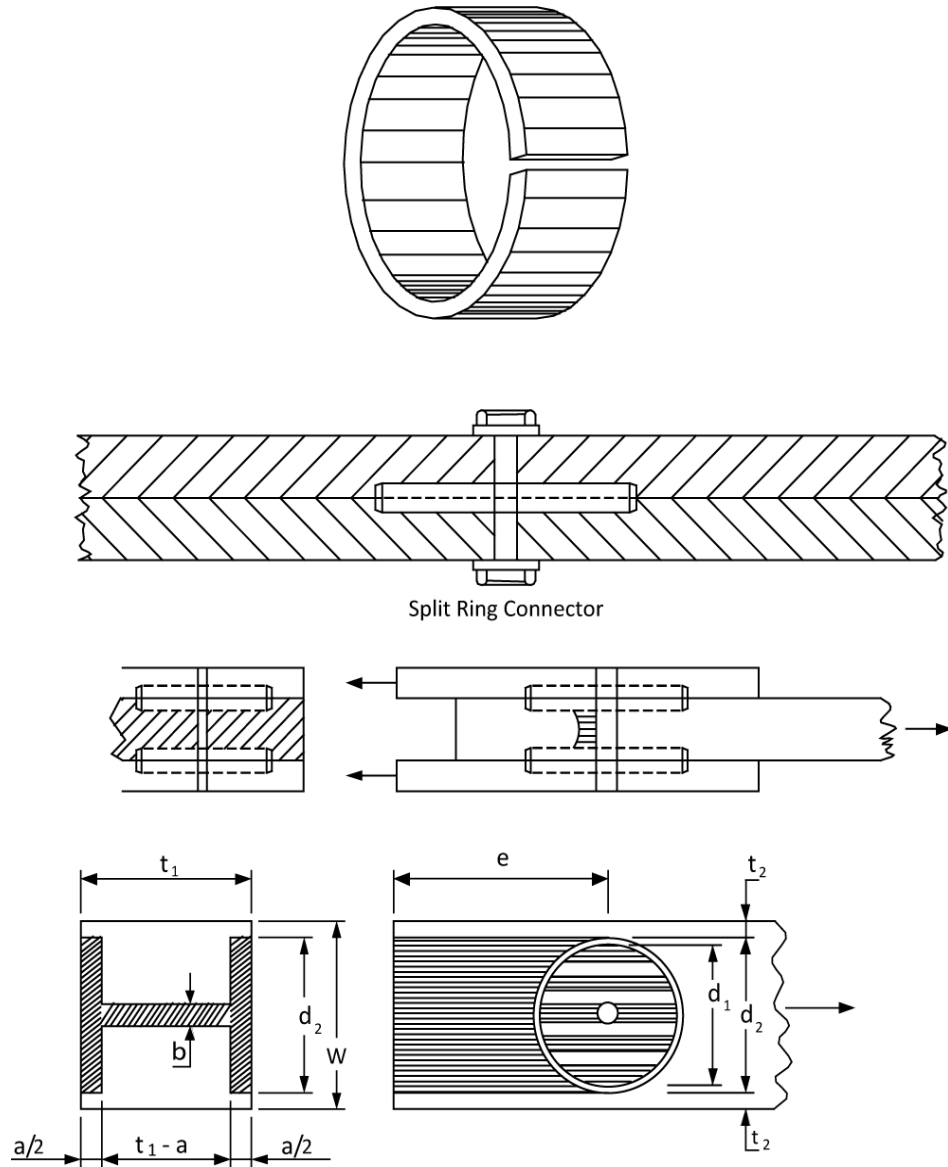


Figure 6.11.8 Stress Distribution In A Split Ring Connector

11.9.3.2 For inclined members, the spacing given above for perpendicular and parallel to grain of wood may be used as a guide and bolts arranged at the joint with respect to loading direction.

11.9.3.3 The bolts shall be arranged in such a manner so as to pass the centre of resistance of bolts through the inter-section of the gravity axis of the members.

11.9.3.4 Staggering of bolts shall be avoided as far as possible in case of members loaded parallel to grain of wood. For loads acting perpendicular to grain of wood, staggering is preferable to avoid splitting due to weather effects.

11.9.3.5 Bolting

The bolt holes shall be bored or drilled perpendicular to the surface involved. Forcible driving of the bolts shall be avoided which may cause cracking or splitting of members. A bolt hole of 1.0 mm oversize may be used as a guide for preboring.

11.9.3.5.1 Bolts shall be tightened after one year of completion of structure and subsequently at an interval of two to three years.

11.9.4 Outline for Design of Bolted Joints

Allowable load on one bolt (unit bearing stress) in a joint with wooden splice plates shall not be greater than value of P, R, F as determined by one of the following equations:

(a) For Loads Parallel to Grain

$$P = f_{cp} a \lambda_1 \quad (6.11.19)$$

(b) For Loads Perpendicular to Grain

$$R = f_{cp} a \lambda_2 d_f \quad (6.11.20)$$

(c) For Loads at an Angle to Grain

$$F = \frac{PR}{P \sin^2 \theta + R \cos^2 \theta} \quad (6.11.21)$$

11.10 Design of Timber Connector Joints

11.10.1 In large span structures, the members have to transmit very heavy stresses requiring stronger jointing techniques with metallic rings or wooden disc-dowels. Improved metallic ring connector is a split circular band of steel made from mild steel pipes. This is placed in the grooves cut into the contact faces of the timber members to be joined, the assembly being held together by means of a connecting bolt.

11.10.1.1 Dimensions of Members Variation of thickness of central (main) and side members affect the load carrying capacity of the joint.

11.10.1.2 The thickness of main member shall be at least 57 mm and that of side member 38 mm with length and width f members governed by placement of connector at joint.

11.10.1.3 The metallic connector shall be so placed that the loaded edge distance is not less than the diameter of the connector and the end distance not less than 1.75 times the diameter on the loaded side.

11.10.1.4 Design Considerations

Figure 11.10.1 illustrates the primary stresses in a split ring connector joint under tension. The shaded areas represent the part of wood in shear, compression and tension. Related formulae for the same are indicated in Figure 6.11.9.

For fabrication of structural members, a hole of the required size of the bolt is drilled into the member and a groove is made on the contact faces of the joint.

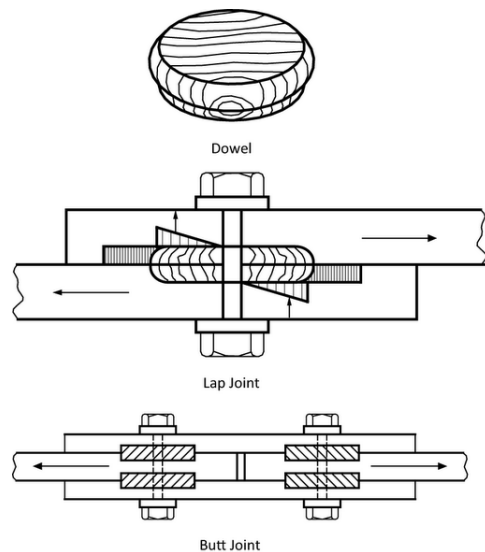
11.10.2 Wooden Disc-Dowel

11.10.2.1 It is a circular hardwood disc generally tapered each way from the middle so as to form a double conical frustum. Such a disc is made to fit into preformed holes (recesses), half in one member and the other half in another, the assembly being held by one mild steel bolt through the centre of the disc to act as a coupling for keeping the jointed wooden members from spreading apart.

11.10.2.2 Dimensions of members

The thickness of dowel may vary from 25 mm to 35 mm and diameter from 50 mm to 150 mm. The diameter of dowel shall be 3.25 to 3.50 times the thickness.

The edge clearance shall range from 12 mm to 20 mm as per the size of the dowel. The end clearance shall be at least equal to the diameter of dowel for joints subjected to tension and three-fourth the diameter for compression joints. Disc-dowel shall be turned from quarter sawn planks of seasoned material.



Lap Joint

But in simple tension due to clockwise turning moment on dowel.

Butt Joint

No tilting moment in dowel due to balancing effect [dowels are in shear (no bending, shearing and tensile stress on bolts)]

Size of dowel for equal strength in both shearing and bearing.

$$\frac{\pi d^2}{4} \times S = d \times \frac{t}{2} \times c$$

Where

d = Mid diameter of the dowel

t = Thickness of dowel

s = Safe working stress in shear along grain, and

c = Safe compressive stress along grain.

Figure 6.11.9 Distribution of forces in dowel joint

11.10.2.3 Choice of species

Wood used for making dowels shall be fairly straight grained, free from excessive liability to shrink and warp, and retain shape well after seasoning species recommended include: (a) Babul, (b) Sissoo, (c) Pyinkado and (d) Yon. Data on the above species as per Table 6.11.1 except for the species Pyinkado, which is not an indigenous species.

11.10.2.4 Design considerations

Figure 11.10.2 illustrates the forces on dowel in a lap joint and butt joint. Dowel is subjected to shearing at the mid-section, and compression along the grain at the bearing surfaces. For equal strength in both the forces, formula equations are given in Figure 6.11.10 to determine the size of dowel.

The making of wooden discs may present some problems in the field, but they may be made in small workshop to the specifications of the designer. This is also economically important. Once the wood fittings are shop tailored and made, the construction process in the field is greatly simplified. Theoretical safe loads in design shall be confirmed through sample tests.

11.11 Glued Laminated Construction and Finger Joints

11.11.1 Developments in the field of synthetic adhesive have brought gluing techniques within the range of engineering practice. Timber members of larger cross-sections and long lengths can be fabricated from small sized planks by the process of gluelam. The term glued laminated timber construction as applied to structural members refers to various laminations glued together, either in straight or curved form, having grain of all laminations essentially parallel to the lengths of the member.

11.11.1.1 Choice of glue

The adhesive used for glued laminated assembly are 'gap filling' type. A 'filler' in powder form is introduced in the adhesive. Structural adhesives are supplied either in powder form to which water is added or in resin form to which a hardener or catalyst is added. However, it is important that only boiling water proof (BWP) grade adhesives shall be used for fabrication of gluelam in tropical, high humid climates.

11.11.1.2 Manufacturing schedule

In absence of a systematic flow-line in a factory, provisions of intermediate technology shall be created for manufacturing structural elements. The schedule involves steps:

- (a) Drying of planks;
- (b) Planning;
- (c) End-jointing by scarfs or fingers;
- (d) Machining of laminations;
- (e) Setting up dry assembly of structural unit;
- (f) Application of glue;
- (g) Assembly and pressing the laminations;
- (h) Curing the glue lines, as specified; and
- (i) Finishing, protection and storage.

11.11.2 Finger joints are glued joints connecting timber members end-to-end (Figure 6.11.11). Such joints shall be produced by cutting profiles (tapered projections) in the form of V-shaped grooves to the ends of timber planks or scantling to be joined, gluing the interfaces and then meeting the two ends together under pressure. Finger joints provide long lengths of timber, ideal for upgrading timber by permitting removal of defects, minimizing warping and reducing wastage by avoiding short off-cuts.

11.11.2.1 In finger joints the glued surfaces are on the side grain rather than on the end grain and the glue line is stressed in shear rather in tension.

11.11.2.2 The fingers can be cut from edge-to-edge or from face-to-face. The difference is mainly in appearance, although bending strength increases if several fingers share the load. Thus a joist is slightly stronger with edge-to-edge finger joints and a plank is stronger with face-to-face finger joint.

11.11.2.3 For structural finger jointed members for interior dry locations, adhesives based on melamine formaldehyde cross linked polyvinyl acetate (PVA) are suited. For high humid and exterior conditions, phenol formaldehyde and resorcinol formaldehyde type adhesives are recommended. Proper adhesives should be selected in consultation with the designer and adhesive manufacturers.

11.11.2.4 Manufacturing process

In the absence of sophisticated machinery, the finger joints shall be manufactured through intermediate technology with the following steps:

- (a) Drying of wood,
- (b) Removal of knots and other defects,
- (c) Squaring the ends of the laminating planks,
- (d) Cutting the profile of finger joint in the end grain,

- (e) Applying adhesives on the finger interfaces,
- (f) Pressing the joint together at specified pressure,
- (g) Curing of adhesive line at specified temperature, and
- (h) Planning of finger-jointed planks for smooth surface.

11.11.2.5 Strength

Strength of finger joints depends upon the geometry of the profile for structural purpose; this is generally 50 mm long, 12 mm pitch.

11.11.2.5.1 End joints shall be scattered in adjacent laminations, which shall not be located in very highly stressed outer laminations.

11.11.2.6 Tip thickness will be as small as practically possible.

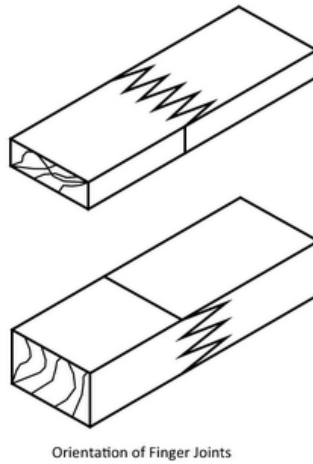
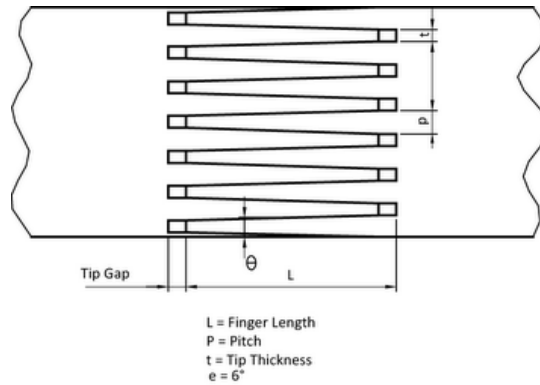


Figure 6.11.10 Typical finger joint geometry

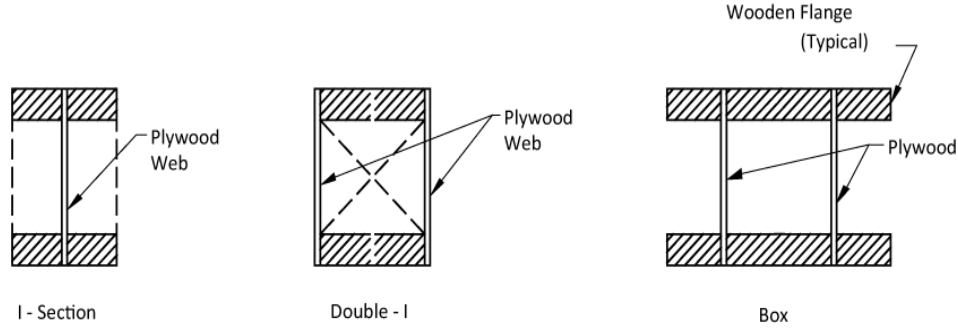


Figure 6.11.11 Typical cross - section of web beams

11.12 Laminated Veneer Lumber

11.12.1 Certain reconstituted lignocellulosic products with fibre oriented along a specific direction have been developed and are being adopted for load bearing applications. Laminated veneer lumber is one such product developed as a result of researches in plantation grown species of wood. Density of laminated veneer lumber ranges from 0.6 to 0.75.

11.12.1.1 Dimensions

Sizes of laminated veneer lumber composite shall be inclusive of margin for dressing and finishing unless manufactured to order. The margin for dressing and finishing shall not exceed 3mm in the width and thickness and 12mm in the length.

11.12.1.2 Permissible defects

- (a) Jointing gaps: Not more than 3 mm wide, provided they are well staggered in their spacing and position between the successive plies.
- (b) Slope of grain: Not exceeding 1 in 10 in the face layers.
- (c) Tight knot: Three numbers up to 25 mm diameter in one square metre provided they are spaced 300 mm or more apart.
- (d) Warp: Not exceeding 1.5 mm per metre length.

11.12.1.3 Strength requirements

The strength requirements for laminated veneer lumber shall be as per Table 6.11.18.

Table 6.11.18: Requirements of Laminated Veneer Lumber

Sl. No.	Properties	Requirement
(i)	Modulus of rupture (N/mm ²), Min	50
(ii)	Modulus of elasticity (N/mm ²), Min	7500
(iii)	Compressive strength:	
	a) Parallel to grain (N/mm ²), Min	35
	b) Perpendicular to grain (N/mm ²), Min	50
(iv)	Horizontal shear:	
	a) Parallel to laminac (N/mm ²), Min	6
	b) Perpendicular to laminac (N/mm ²), Min	8
(v)	Tensile strength parallel to grain (N/mm ²), Min	55
(vi)	Screw holding power:	
	a) Edge (N), Min	2300
	b) Face (N), Min	2700
(vii)	Thickness swelling in 2 h water soaking (percent), Max	3

11.13 Design of Glued Laminated Beams

11.13.1 General

Glued laminated structural members shall be fabricated only where there are adequate facilities for accurate sizing and surfacing of planks, uniform application of glue, prompt assembly, and application of adequate pressure and prescribed temperature for setting and curing of the glue. Design and fabrication shall be in accordance with established engineering principles and good practice. A glued laminated beam is a straight member made from a number of laminations assembled both ways either horizontally or vertically. While vertical laminations have limitations in restricting the cross-section of a beam by width of the plank, horizontally laminated section offers wider scope to the designer in creating even the curved members.

Simple straight beams and joists are used for many structures from small domestic rafters or ridges to the light industrial structures.

11.13.2 Design

The design of glue laminated wood elements shall be in accordance with good engineering practice and shall take into consideration the species and grade of timber used, presence of defects, location of end joints in laminations, depth of beams and moisture contents

expected while in service. Beams of large spans shall be designed with a suitable camber to assist in achieving the most cost effective section where deflection governs the design. The strength and stiffness of laminated beams is often governed by the quality of outer laminations. Glued laminated beams can be tapered to follow specific roof slopes across a building and/or to commensurate with the varying bending moments.

11.13.3 Material

Laminating boards shall not contain decay, knots or other strength reducing characteristics in excess of those sizes or amounts permitted by specifications. The moisture content shall approach that expected in service and shall in no case exceed 15 percent at the time of gluing. The moisture content of individual laminations in a structural member shall not differ by more than 3 percent at the time of gluing. Glue shall be of type suitable for the intended service of a structural member.

11.13.4 Fabrication/Manufacture

In order to assure a well-bonded and well-finished member of true shape and size, all equipment, end-Jointing, glue spread, assembly, pressing, curing or any other operation in connection with the manufacture of glued structural members shall be in accordance with the available good practices and as per glue manufacturers' instructions as applicable.

11.14 Structural Use of Plywood

Unlike sawn timber, plywood is a layered panel product comprising veneers of wood bonded together with adjacent layers usually at right angles. As wood is strongest when stressed parallel to grain, and weak perpendicular to grain, the lay up or arrangement of veneers in the panel determines its properties. When the face grain of the plywood is parallel to the direction of stress, veneers parallel to the face grain carry almost all the load. Some information/guidelines for structural use of plywood are given in Sections 11.14.1 to 11.14.3.

11.14.1 The plywood has a high strength to weight ratio, and is dimensionally stable material available in sheets of a number of thicknesses and construction. Plywood can be sawn, drilled and nailed with ordinary wood working tools. The glues used to bond these veneers together are derived from synthetic resins which are set and cured by heating. The properties of adhesives can determine the durability of plywood.

11.14.2 In glued plywood construction, structural plywood is glued to timber resulting in highly efficient and light structural components like web beams (I and box sections), (Figures 6.11.12 and 6.11.13) stressed skin panels (Figure 6.11.14) used for flooring and walling and pre-fabricated houses, cabins, etc.

Gluing can be carried out by nail gluing techniques with special clamps. High shear strength of plywood in combination with high flexural strength and stiffness of wood result in structures characterized by high stiffness for even medium spans. Plywood can act as web transmitting shear stress in web bearing or stressed skin or sandwich construction. The effective moment of inertia of web beam and stressed skin construction depends on modular ratio that is, E of wood to E of plywood.

11.14.3 Structural plywood is also very efficient as cladding material in wood frame construction, such as houses. This type of sheathing is capable of resisting racking due to wind and quack forces. Structural plywood has been widely used as diaphragm (horizontal) as in roofing and flooring in timber frame construction. It has been established that 6 mm thick plywood can be used for sheathing and even for web and stressed skin construction, 9-12 mm thick plywood is suitable for beams, flooring diaphragms, etc. Phenol formaldehyde (PF) and PRF adhesive are suitable for fabrication of glued plywood components. 6 mm-12 mm thick structural plywood can be very well used as nailed or bolted gussets in fixing members of trusses or lattice girders or trussed rafters.

Normally, scarf joints are used for fixing plywood to required length and timber can be joined by using either finger or scarf joints. Arch panels, folded plates, shelves are other possibilities with this technique.

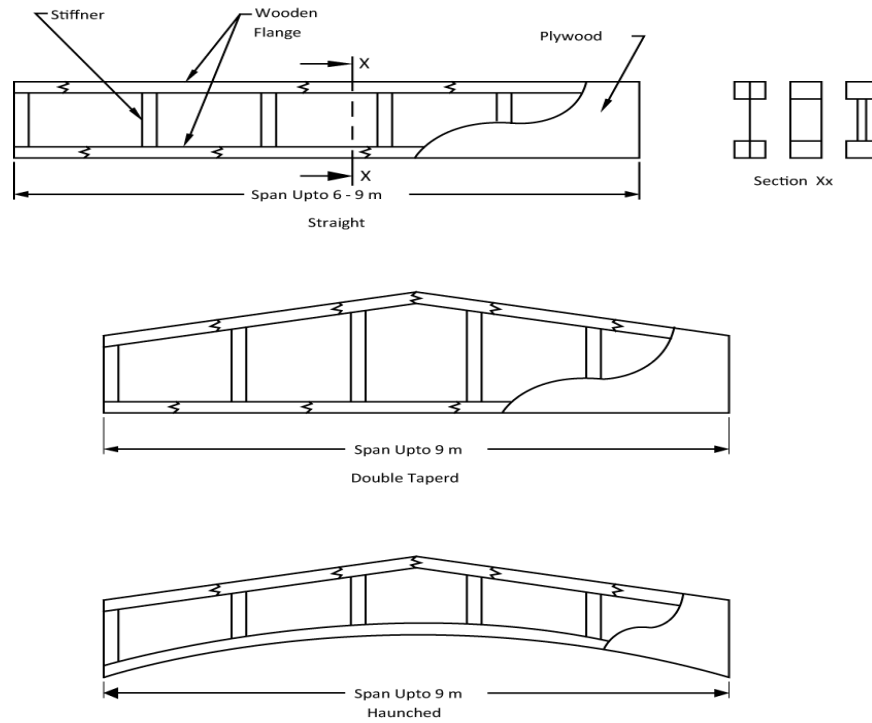


Figure 6.11.12 Web beam configurations

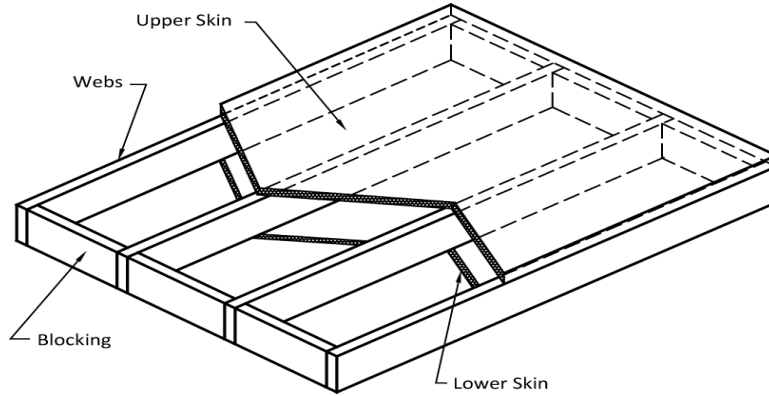


Figure 6.11.13 Stressed skin panel construction (Single Skin Or Double Skin)

11.15 Trussed Rafter

11.15.1 General

A roof truss is essentially a plane structure which is very stiff in the plane of the members, that is, the plane in which it is expected to carry loads, but very flexible in every other direction. Thus it can virtually be seen as a deep, narrow girder liable to buckling and twisting under loads. In order, therefore, to reduce this effect, eccentricity of loading and promote prefabrication for economy, low-pitched trussed rafters are designed with bolt ply/nail ply joints. Plywood as gussets, besides being simple have inherent constructional advantage of grain over solid wood for joints, and a better balance is achievable between the joint strength and the member strength.

Trussed rafters are light weight truss units spaced at close centres for limited spans to carry different types of roof loads. They are made from timber members of uniform thickness fastened together in one plane. The plywood gussets may be nailed or glued to the timber to form the joints. Conceptually a trussed rafter is a triangular pin jointed system, traditionally meant to carry the combined roof weight, cladding services and wind loads. There is considerable scope for saving timber by minimizing the sections through proper design without affecting structural and functional requirements.

Trussed rafters require to be supported only at their ends so that there is no need to provide load bearing internal walls, purlins, etc. and in comparison with traditional methods of construction they use less timber and considerably reduces site labour. Mass production of reliable units can be carried out under workshop controls.

11.15.2 Design

Trussed rafter shall be designed to sustain the dead and imposed loads specified in Chapter 2 Part 6 and the combinations expected to occur. Extra stresses/deflections during handling, transportation and erection shall be taken care of. Structural analysis, use of load-slip and moment, rotation characteristics of the individual joints may be used if feasible. Alternatively the maximum direct force in a member maybe assessed to be given by an idealized pin-jointed framework, fully loaded with maximum dead and imposed load in the combination in which they may reasonably be expected to occur.

11.15.3 Timber

The species of timber including plantation grown species which can be used for trussed rafter construction and permissible stresses thereof shall be in accordance with Table 6.11.1. Moisture contents to be as per zonal requirements in accordance with Sec 11.4.4.

11.15.4 Plywood

Boiling water resistant (BWR) grade preservative treated plywood shall be used. Introduction of a plywood gusset simplifies the jointing and in addition provides rigidity to the joint. Preservation of plywood and other panel products shall be done in accordance with good practice prescribed by Bangladesh Forest Research Institute, Chittagong.

11.16 Structural Sandwiches**11.16.1 General**

Sandwich constructions are composites of different materials including wood based materials formed by bonding two thin facings of high strength material to a light weight core which provides a combination of desirable properties that are not attainable with the individual constituent materials (Figure 6.11.14). The thin facings are usually of strong dense material since that are the principal load carrying members of the construction. The core must be stiff enough to ensure the faces remain at the correct distance apart. The sandwiches used as structural elements in building construction shall be adequately designed for their intended services and shall be fabricated only where there are adequate facilities for gluing or otherwise bonding cores to facings to ensure a strong and durable product. The entire assembly provides a structural element of high strength and stiffness in proportion to its mass.

Non-structural advantages can also be derived by proper selection of facing and core material for example, an impermeable facings can be used to serve as a moisture barrier for walls and roof panels and core may also be selected to provide thermal and/or acoustic insulation, fire resistance, etc., besides the dimensional stability.

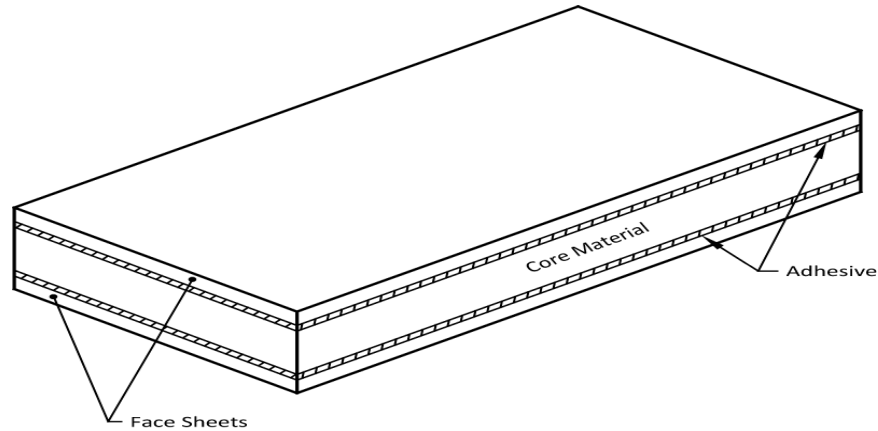


Figure 6.11.14 Sandwich construction in structural applications

11.16.2 Cores

Sandwich cores shall be of such characteristics as to give to the required lateral support to the stressed facings to sustain or transmit the assumed loads or stresses. Core generally carries shearing loads and to support the thin facings due to compressive loads. Core shall maintain the strength and durability under the conditions of service for which their use is recommended. A material with low E and small shear modulus may be suitable.

11.16.3 Facings

Facings shall have sufficient strength and rigidity to resist stresses that may come upon them when fabricated into a sandwich construction. They shall be thick enough to carry compressive and tensile stresses and to resist puncture or denting that maybe expected in normal usages.

11.16.4 Designing

Structural designing may be comparable to the design of I-beams, the facings of the sandwich represent the flanges of the I-beam and the sandwich core I-beam web.

11.16.5 Tests

Tests shall include, as applicable, one or more of the following:

- (a) Flexural strength and stiffness,
- (b) Edge-wise compressions,
- (c) Flat-wise compression,
- (d) Shear in flat-wise plane,
- (e) Flat-wise tensions,
- (f) Flexural creep (creep behaviour of adhesive),
- (g) Cantilever vibrations (dynamic property), and
- (h) Weathering for dimensional stability.

11.17 Lamella Roofing**11.17.1 General**

The Lamella roofing offers an excellent architectural edifice in timber, amenable to prefabrication, light weight structure with high central clearance. It is essentially an arched structure formed by a system of intersecting skewed arches built-up of relatively short timber planks of uniform length and cross-section. Roof is designed as a two hinged arch with a depth equal to the depth of an individual lamella and width equal to the span of the building. The curved lamellas (planks) are bevelled and bored at the ends and bolted together at an angle, forming a network (grid) pattern of mutually braced and stiffened members (Figure 6.11.15). The design shall be based on the balanced or unbalanced assumed load distribution used for roof arches. Effect of deformation or slip of joints under load on the induced stresses shall be considered in design. Thrust components in both transverse and longitudinal directions of the building due to skewness of the lamella arch shall be adequately resisted. Thrust at lamella joints shall be resisted by the moment of inertia in the continuous lamella and roof sheathing (decking) of lamella roofing. The interaction of arches in two directions adds to the strength and stability against horizontal forces. For design calculations several assumption tested and observed derivations, long-duration loading factors, seasoning advantages and effects of defects are taken into account.

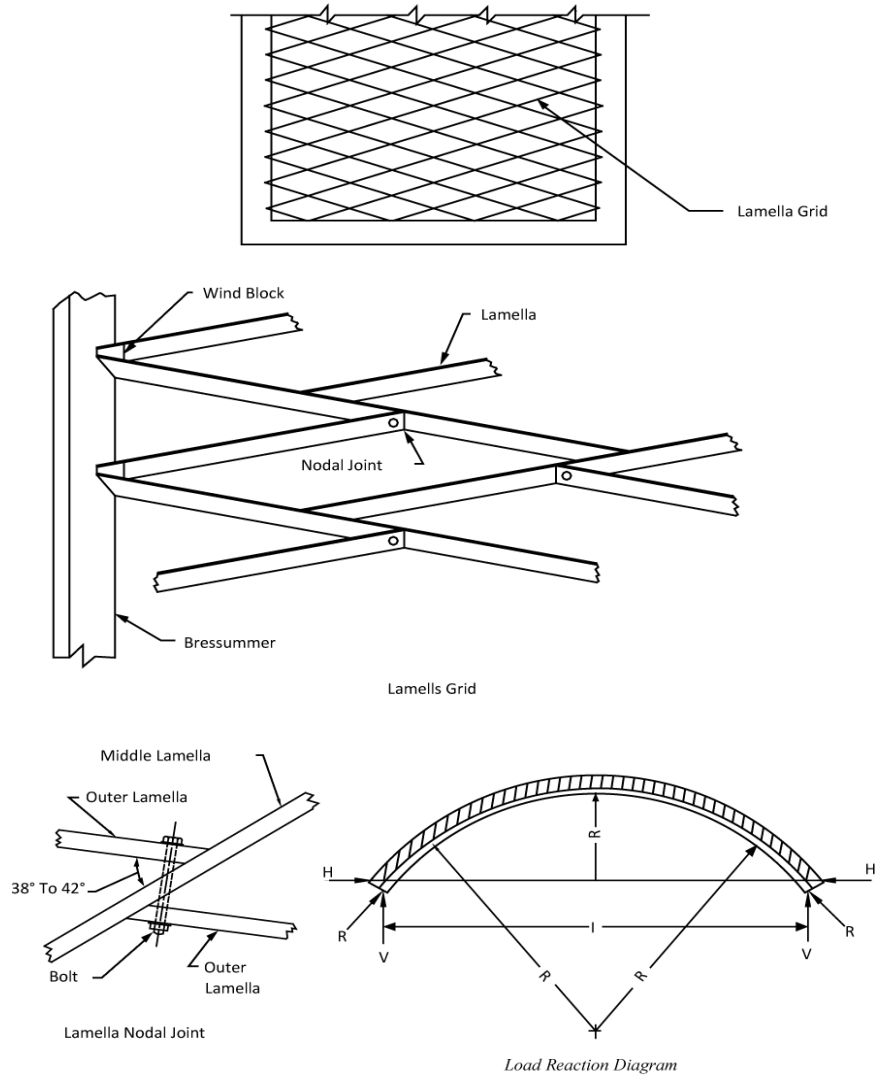


Figure 6.11.15: Typical arrangement of lamella roofing

11.17.2 Lamellas

Planking shall be of a grade of timber that is adequate in strength and stiffness to sustain the assumed loads, forces, thrust and bending moments generated in Lamella roofing. Lamella planks shall be seasoned to a moisture content approximating that they will attain in service. Lamella joints shall be proportioned so that allowable stresses at bearings of the non-continuous lamellas on the continuous lamellas or bearings under the head or washer of bolts are not exceeded.

11.17.3 Construction

Design and construction of lamella roofs in India assumes the roof surfaces to be cylindrical with every individual lamella an elliptic segment of an elliptical arch of constant curved length but of different curvature. Lamella construction is thus more of an art than science as there is no analytical method available for true generation of schedule of cutting lengths and curvature of curved members forming the lamella grid. Dependence of an engineer on the practical ingenuity of master carpenter is almost final. All the lamella joints shall be accurately cut and fitted to give full bearing without excessive deformation or slip. Bolts at lamella splices shall be adequate to hold the members in their proper position and shall not be over tightened to cause bending of the lamellas or mashing of wood under the bolt heads. Connection of lamellas to the end arches shall be adequate to transmit the thrust or any other force. Sufficient false work or sliding jig shall be provided for the support of lamella roof during actual construction/erection.

11.18 Nail and Screw Holding Power of Timber

11.18.1 General

One of the most common ways of joining timber pieces to one another is by means of common wire nails and wood screws. Timber is used for structural and nonstructural purposes in form of scantlings, rafters, joists, boarding, crating and packing cases, etc. needing suitable methods of joining them. Nevertheless it is the timber which holds the nails or screws and as such pulling of the nails/screws is the chief factor which come into play predominantly. In structural nailed joints, nails are essentially loaded laterally, the design data for which is already available as standard code of practice. Data on holding power of nails/screws in different species is also useful for common commercial purposes. The resistance of mechanical fastenings is a function of the specific gravity of wood, direction of penetration with respect to the grain direction, depth of penetration and the diameter of fastener assuming that the spacing of fasteners should be adequate to preclude splitting of wood.

11.18.2 Nails

Nails are probably the most common and familiar fastener. They are of many types and sizes in accordance with the accepted standards.

In general nails give stronger joints when driven into the side grain of wood than into the end grain. Nails perform best when loaded laterally as compared to axial withdrawal so the nailed joints should be designed for lateral nail bearing in structural design. Information on withdrawal resistance of nails is available and joints may be designed for that kind of loading as and when necessary.

11.18.3 Screw

Next to the hammer driven nails, the wood screw may be the most commonly used fastener. Wood screws are seldom used in structural work because of their primary advantage is in withdrawal resistance, for example, for fixing of ceiling “boards to joists, purlin cleats, besides the door hinges etc. They are of considerable structural importance in fixture design and manufacture. Wood screws are generally finished in a variety of head shapes and manufactured in various lengths for different screw diameters or gauges.

The withdrawal resistance of wood screws is a function of screw diameter, length of engagement of the threaded portion into the member, and the specific gravity of the species of wood. Withdrawal load capacity of wood screws are available for some species and joints may be designed accordingly. End grain load on wood screws are unreliable and wood screws shall not be used for that purpose.

11.19 Protection Against Termite Attack in Buildings

11.19.1 Two groups of organisms which affect the mechanical and aesthetic properties of wood in houses are fungi and insects. The most important wood destroying insects belong to termites and beetles. Of about 250 species of wood destroying termites recorded in India, not more than a dozen species attack building causing about 90 percent of the damage to timber and other cellulosic materials. Subterranean termites are the most destructive of the insects that infest wood in houses justifying prevention measures to be incorporated in the design and construction of buildings.

11.19.1.1 Control measures consist in isolating or sealing off the building from termites by chemical and non-chemical construction techniques. It is recognized that 95 percent damage is due to internal travel of the termites from ground upwards rather than external entry through entrance thus calling upon for appropriate control measures in accordance with good practices.

11.19.2 Chemical Methods

Termites live in soil in large colonies and damage the wooden structure in the buildings by eating up the wood or building nests in the wood. Poisoning the soil under and around the building is a normal recommended practice. Spraying of chemical solution in the trenches of foundations in and around walls, areas under floors before and after filling of earth, etc. In already constructed building the treatment can be given by digging trenches all around the building and then giving a liberal dose of chemicals and then closing the trenches.

11.19.3 Wood Preservatives

Natural resistance against organisms of quite a few wood species provides durability of timber without special protection measure. It is a property of heartwood while sapwood is normally always susceptible to attack by organisms. Preservatives should be well applied with sufficient penetration into timber. For engineers, architects and builders, the following are prime considerations for choice of preservatives:

- (a) Inflammability of treated timber is not increased and mechanical properties are not decreased;
- (b) Compatibility with the glue in laminated wood, plywood and board material;
- (c) Water repellent effect is preferred;
- (d) Possible suitability for priming coat;
- (e) Possibility of painting and other finishes;
- (f) Non-corrosive nature fasteners; and
- (g) Influence on plastics, in case of metal rubber, tiles and concrete.

11.19.4 Constructional Method

Protection against potential problem of termite attack can simply be carried out by ordinary good construction which prevents a colony from gaining access by:

- (a) periodic visual observations on termite galleries to be broken off;
- (b) specially formed and properly installed metal shield at plinth level; and
- (c) continuous floor slabs, apron floors and termite grooves on periphery of buildings.

PART VI
Chapter 12
Ferrocement Structures

12.1 Scope

This Chapter covers selection, standards and testing of ferrocement materials, design criteria and approaches, construction methods, and maintenance and repair procedures of ferrocement structures. The provisions of this Chapter are consistent with those of Chapter 6, except for the special requirements of ferrocement, such as reinforcement cover and limits on deflection.

12.2 Terminology

12.2.1 Reinforcement Parameters

For the purpose of this Chapter, the following parameters characterizing the reinforcement in ferrocement shall have the definitions given:

ARMATURE	The total reinforcement system or skeletal reinforcement and mesh for a ferrocement element.
EFFECTIVE MODULUS OF THE REINFORCEMENT	For welded steel meshes, effective modulus of the reinforcing system, E_r shall be taken equal to the elastic modulus of the steel wires. For other meshes, E_r shall be determined from tensile tests on the ferrocement composite as specified in Sec 12.8.
LONGITUDINAL DIRECTION	The roll direction (longer direction) of the mesh as produced in plant (see Figure 6.12.1).
SKELETAL REINFORCEMENT	A planar framework or widely spaced tied steel bars that provides shape and support for layers of mesh or fabric attached to either side.
SPECIFIC SURFACE OF REINFORCEMENT	Specific Surface of Reinforcement S_r is the total bonded area of reinforcement (interface area or area of the steel that comes in contact with the mortar) divided by the volume of the composite. For a ferrocement plate of width b and depth h , the specific surface of reinforcement can be computed from $S_r = \frac{\sum o}{bh}$, in which $\sum o$ is the total surface area of bonded reinforcement per unit length.

The relation between S_r and V_f when square grid wire meshes are used is $S_r = \frac{4V_f}{d_b}$, Where, d_b is the diameter of the wire.

For other types of reinforcement, such as expanded metal, S_{rl} and S_{rt} may be unequal.

SPRITZING	Spraying or squirting a mortar onto a surface.
TRANSVERSE DIRECTION	Direction of mesh normal to its longitudinal direction; also width direction of mesh as produced in plant (see Figure 6.12.1)
VOLUME FRACTION OF REINFORCEMENT (V_f)	Volume fraction of reinforcement is the total volume of reinforcement divided by the volume of composite (reinforcement and matrix). For a composite reinforced with meshes with square openings, V_f shall be equally divided into V_{fl} and V_{ft} for the longitudinal and transverse directions, respectively. For other types of reinforcement, such as expanded metal, V_{fl} and V_{ft} may be unequal. Procedures for computation of V_f are shown in Appendix U.

12.2.2 Illustration of Terminologies

Figure 6.12.1 illustrates the various terminologies used in Sec 12.2.1.

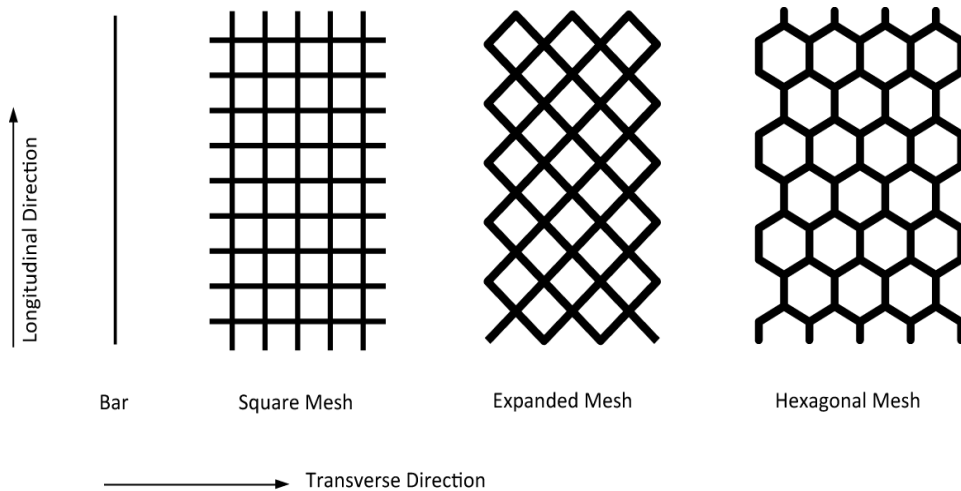


Figure 6.12.1 Assumed Longitudinal and Transverse Directions of Reinforcement

12.2.3 Notation and Symbols

A_c = Cross-sectional area of ferrocement composite

A_s	=	Total effective cross-sectional area of reinforcement in the direction considered, $A_s = \sum_{i=1}^N A_{si}$
A_{si}	=	Effective cross-sectional area of reinforcement of mesh layer i in the direction considered
C_c	=	Resultant of the compressive stress block in ferrocement
C_{si}	=	Compressive force in ferrocement layer i
E_c	=	Elastic modulus of mortar matrix
E_r	=	Effective modulus of the reinforcing system
M_n	=	Nominal moment strength
N_n	=	Nominal tensile strength
N	=	Number of layers of mesh; nominal resistance
S_r	=	Specific surface of reinforcement
S_{rl}	=	Specific surface of reinforcement in the longitudinal direction
S_{rt}	=	Specific surface of reinforcement in the transverse direction
T_{si}	=	Tensile force in the ferrocement layer i
V_f	=	Volume fraction of reinforcement
U	=	Minimum required design strength
V_{fi}	=	Volume fraction of reinforcement for mesh layer i
V_{fl}	=	Volume fraction of reinforcement in the longitudinal direction
V_{ft}	=	Volume fraction of reinforcement in the transverse direction
b	=	Width of ferrocement section
c	=	Distance from extreme compression fibre to neutral axis
d_c	=	Clear cover of mortar over first layer of mesh
d_b	=	Diameter or equivalent diameter of reinforcement used

d_i	=	Distance from extreme compression fibre to centroid of reinforcing layer i
f'_c	=	Specified compressive strength of ferrocement mortar
f_y	=	Yield strength of mesh reinforcement or reinforcing bars
h	=	Thickness of ferrocement section
n_r	=	Modular ratio of reinforcement
s	=	Mesh opening or size
β_1	=	Factor defining depth of rectangular stress block
η	=	Global efficiency factor of embedded reinforcement in resisting tension or tensile bending loads
η_l	=	Value of η when the load or stress is applied along the longitudinal direction of the mesh system or rod reinforcement
η_t	=	Value of η when the load or stress is applied along the transverse direction of the mesh reinforcement system or rod reinforcement
η_θ	=	Value of η when the load or stress is applied along a direction forming an angle with the longitudinal direction
ϵ_{si}	=	Strain of mesh reinforcement at layer i
ϵ_y	=	Nominal yield strain of mesh reinforcement = $\frac{f_y}{E_r}$
Σ_o	=	Total surface area of bonded reinforcement per unit length
ϕ	=	Strength reduction factor.

12.3 Materials

The material used in ferrocement consists primarily of mortar made of Portland cement, water and aggregate and the reinforcing mesh.

12.3.1 Cement

The cement shall comply with BDS EN 197-1 or an equivalent standard. The cement shall be fresh, of uniform consistency, and free of lumps and foreign matter. It shall be stored under dry conditions for as short a duration as possible.

The choice of a particular cement shall depend on the service conditions. Service conditions can be classified as electrochemically passive or active. Land based structures such as ferrocement silos, bins, and water tanks can be considered as passive structures, except when in contact with sulphate bearing soils, in which case the use of sulphate resistant cement, such as ASTM Type II or Type V, may be necessary.

Blended hydraulic cement conforming to ASTM C595 Type 1 (PM), IS, 1 (SM), IS-A, IP, or IP-A can also be used.

Mineral admixtures, such as fly ash, silica fumes, or blast furnace slag, may be used to maintain a high volume fraction of fine filler material. When used, mineral admixtures shall comply with ASTM C618 and C989. In addition to the possible improvement of flow ability, these materials also benefit long term strength gain, lower mortar permeability, and in some cases improved resistance to sulphates and chlorides.

12.3.2 Aggregates

Aggregate used in ferrocement shall be normal weight fine aggregate (sand). It shall comply with ASTM C33 requirements (for fine aggregate) or an equivalent standard. It shall be clean, inert, free of organic matter and deleterious substances, and relatively free of silt and clay.

The grading of fine aggregate shall be in accordance with the guidelines of Table 6.12.1. However, the maximum particle size shall be controlled by construction constraints such as mesh size and distance between layers. A maximum particle size passing sieve No. 16 (1.18 mm) may be considered appropriate in most applications. The sand shall be uniformly graded unless trial testing of mortar workability permits the use of a gap graded sand.

Aggregates that react with the alkalis in cement shall be avoided. When aggregates may be reactive, they shall be tested in accordance with ASTM C227. If proven reactive, the use of a pozzolan to suppress the reactivity shall be considered and evaluated in accordance with ASTM C441.

Table 6.12.1: Guidelines for Grading of Sand

Sieve Size U.S. Standard Square Mesh	Percent Passing by Weight
No. 8 (2.36 mm)	80 - 100
No. 16 (1.18 mm)	50 - 85
No. 30 (0.60 mm)	25 - 60
No. 50 (0.30 mm)	10 - 30
No. 100 (0.15 mm)	2 - 10

12.3.3 Water

The mixing water shall be fresh, clean, and potable. The water shall be relatively free from organic matter, silt, oil, sugar, chloride, and acidic material. It shall have a $\text{pH} \geq 7$ to minimize the reduction in pH of the mortar slurry. Salt water is not acceptable, but chlorinated drinking water can be used.

12.3.4 Admixtures

Conventional and high range water reducing admixtures (super plasticizers) shall conform to ASTM C494. Water reducing admixtures may be used to achieve an increase in sand content for the same design strength or a decrease in water content for the same workability. Decreases in water content result in lower shrinkage and less surface crazing. Retarders may be used in large time consuming plastering projects, especially in hot weather conditions.

If water tightness is important, such as in water or liquid retaining structures, special precautions shall be taken. To achieve water tightness, the water cement ratio shall preferably be kept below 0.4, crack widths limited (see Sec 12.4) and, if necessary, waterproofing coatings applied (see Sec 12.6.3).

Mineral admixtures such as fly ash (ASTM C618) can be added to the cement to increase workability and durability. Normally, 15 percent of the cement can be replaced with mineral admixtures without appreciably reducing the strength. Pozzolanic admixtures may be added to replace part of the fine aggregates to improve plasticity. The tendency for some natural pozzolans to absorb water and thus adversely affect hydration of the cement phase shall be checked by measuring the water of absorption.

A quality matrix can be obtained without using any admixtures if experience has shown its applicability. Admixtures not covered in ASTM standards shall not be used.

12.3.5 Mix Proportioning

The ranges of mix proportions for common ferrocement applications shall be sand cement ratio by weight, 1.5 to 2.5, and water cement ratio by weight, 0.35 to 0.5. The higher the sand content, the higher the required water content to maintain the same workability. Fineness modulus of the sand, water cement ratio, and sand cement ratio shall be determined from trial batches to ensure a mix that can infiltrate (encapsulate) the mesh and develop a strong and dense matrix.

The moisture content of the aggregate shall be considered in the calculation of required water. Quantities of materials shall preferably be determined by weight. The mix shall be as stiff as possible, provided it does not prevent full penetration of the mesh. Normally the slump of fresh mortar shall not exceed 50 mm. For most applications, 28 day compressive strength of 75×150 mm moist cured cylinders shall not be less than 35 N/mm^2 .

12.3.6 Reinforcement

The reinforcement shall be clean and free from deleterious materials such as dust, loose rust, coating of paint, oil, or similar substances.

Wire mesh with closely spaced wires is the most commonly used reinforcement in ferrocement. Expanded metal, welded wire fabric, wires or rods, prestressing tendons, and discontinuous fibers may also be used in special applications or for reasons of performance or economy.

12.3.6.1 Wire mesh

Reinforcing meshes for use in ferrocement shall be evaluated for their susceptibility to take and hold shape as well as for their strength performance in the composite system. Common types and sizes of steel meshes that may be used in ferrocement are provided in Appendix U.

12.3.6.2 Welded wire fabric

Welded wire fabric may be used in combination with wire mesh to minimize the cost of reinforcement. The fabric shall conform to ASTM A496 and A497. The minimum yield strength of the wire measured at a strain of 0.035 shall be 410 N/mm^2 . Welded wire fabric normally contains larger diameter wires (2 mm or more) spaced at 25 mm or more.

12.3.6.3 Expanded metal mesh reinforcement

Expanded mesh reinforcement (metal lath), formed by slitting thin gauge steel sheets and expanding them in a direction perpendicular to the slits may be used in ferrocement. Punched or otherwise perforated sheet products may also be used. Expanded mesh is suitable for tanks if proper construction procedures are adopted.

12.3.6.4 Bars, wires and prestressing strands

Reinforcing bars and prestressing wires or strands may be used in combination with wire meshes in relatively thick ferrocement elements or in the ribs of ribbed or T-shaped elements.

Reinforcing bars shall conform to ASTM A615, A616 or A617. Reinforcing bars shall be steel with a minimum yield strength of 410 N/mm² and a tensile strength of about 615 N/mm². Prestressing wires and strands, whether prestressed or not shall conform to ASTM A421 and A416, respectively.

12.3.6.5 Discontinuous fibres and nonmetallic reinforcement

Fibre reinforcement consisting of irregularly arranged continuous filaments of synthetic or natural organic fibres such as jute and bamboo may be used in ferrocement. If organic materials are used, care shall be taken to conduct appropriate investigations to ensure the strength and durability of the finished ferrocement product.

12.4 Design

12.4.1 General Principles and Requirements

12.4.1.1 The analysis of a ferrocement cross-section subject to either bending, or to bending and axial load, whether based on strength or working stresses, is similar to the analysis of a reinforced concrete beam or column having several layers of steel (Figure 6.12.2).

12.4.1.2 In the design of ferrocement structures, members shall be proportioned for adequate strength as per the provisions of this Chapter using load factors and strength reduction factors specified in Chapter 6.

12.4.1.3 Ferrocement members may alternatively be designed using service loads and permissible service load stresses in accordance with the provisions of Sec 12.4.3.

12.4.1.4 All members shall also be designed to satisfy serviceability criteria in accordance with the provisions of Sec 12.4.4.

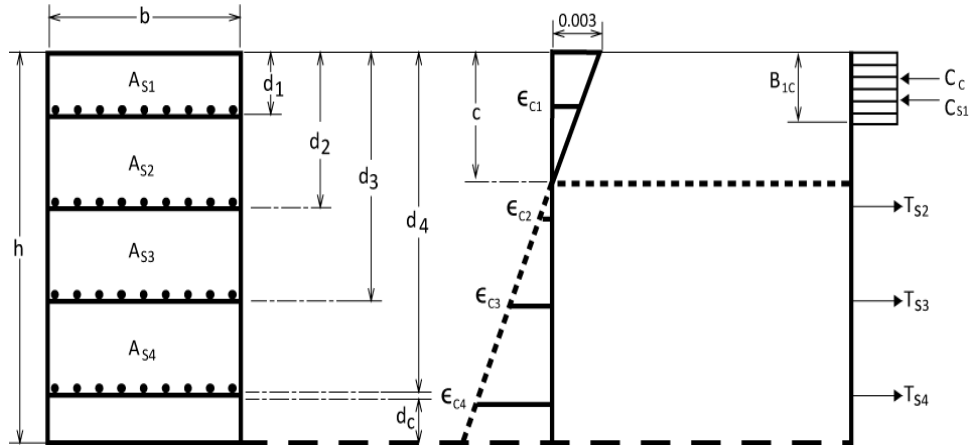


Figure 6.12.2 Strain and force distribution at ultimate in a ferrocement section under bending

12.4.2 Strength Requirements

Ferrocement structures and structural members shall have a design strength at all sections at least equal to the required strengths for the factored load and load combinations stipulated in Chapter 1, General Design Requirements. Required strength U to resist dead load D and live load L shall be determined in accordance with the provisions of Sec 2.7.3.1 Chapter 2 of this Part.

Design strength provided by a member or cross-section in terms of axial load, bending moment, shear force, or stress shall be taken as the nominal strength calculated in accordance with requirements and assumptions of Sec 6.1.4 Chapter 6 multiplied by the strength reduction factor ϕ to satisfy the general relationship.

$$U \leq \phi N \quad (6.12.1)$$

Where, U is the factored load (equal to the minimum required design strength), N is the nominal resistance, and ϕ is a strength reduction factor defined in Sec 6.2.3.1.

Design strength for the mesh reinforcement shall be based on the yield strength f_y of the reinforcement but shall not exceed 690 N/mm^2 . Design yield strengths of various mesh reinforcement shall be in accordance with Table 6.12.2. These shall be used for design only when test data are not available. When tests for determination of yield strength are needed, they shall be conducted in accordance with Sections 12.8.2.3 and 12.8.2.4.

Table 6.12.2: Minimum Values of Yield Strength and Effective Modulus for Steel Meshes and Bars Recommended for Design

Strength and Effective Modulus		Woven Square Mesh	Welded Square Mesh	Hexagonal Mesh	Expanded Metal Mesh	Longitudinal Bars
Yield Strength	f_y N/mm ²	450	450	310	310	410
Effective Modulus	$(E_r)_{long}$ (N/mm ²)	138000	200000	104000	138000	200000
	$(E_r)_{tran}$ (N/mm ²)	165000	200000	69000	69000	-

12.4.2.1 Flexure

The strain distribution at nominal moment resistance shall be assumed to be linear, and a rectangular stress block shall be used in computing the resultant compressive force acting on the concrete.

- (a) Assumptions - Strength design of ferrocement members for flexure and axial loads shall be based on the following assumptions and on satisfaction of equilibrium and compatibility of strains.
 - (i) Strain in reinforcement and mortar (concrete) shall be assumed directly proportional to the distance from the neutral axis.
 - (ii) Maximum strain at extreme mortar (concrete) compression fibre shall be assumed equal to 0.003.
 - (iii) Stress in reinforcement below specified yield strength f_y shall be taken as E_r times steel strain. For strains greater than that corresponding to f_y stress in reinforcement shall be considered independent of strain and equal to f_y .
 - (iv) Tensile strength of mortar (concrete) shall be neglected in flexural strength calculations.
 - (v) Relationship between mortar (concrete) compressive stress distribution and mortar (concrete) strain may be considered satisfied by the use of the equivalent rectangular concrete stress distribution.

- (b) Effective area of reinforcement - The area of reinforcement per layer of mesh considered effective to resist tensile stresses in a cracked ferrocement section shall be determined as follows:

$$A_{si} = \eta V_{fi} A_c \quad (6.12.2)$$

Where,

- A_{si} = effective area of reinforcement for mesh layer i
 η = global efficiency factor of mesh reinforcement in the loading direction considered
 V_{fi} = volume fraction of reinforcement for mesh layer i
 A_c = gross cross-sectional area of mortar (concrete) section.

The global efficiency factor η when multiplied by the volume fraction of reinforcement, gives the equivalent volume fraction (or equivalent reinforcement ratio) in the loading direction considered. In effect, it leads to an equivalent (effective) area of reinforcement per layer of mesh in that loading direction.

For square meshes, $\eta = 0.5$ when loading is applied in one of the principal directions. For a reinforcing bar loaded along its axis, $\eta = 1.0$.

In the absence of values derived from tests for a particular mesh system, the values of η given in Table 6.12.3 for common types of mesh and loading direction may be used. The global efficiency factor shall apply whether the reinforcement is in the tension zone or in the compression zone.

The value of $\eta = 0.2$ for expanded metal mesh (Table 6.12.3) may not always be conservative, particularly in thicker sections in flexure with the mesh oriented in the short way diamond. The values in Table 6.12.3 shall be used for sections 50 mm or less in thickness, and tests conducted for global efficiency values for sections more than 50 mm in thickness.

Table 6.12.3: Recommended Design Values of the Global Efficiency Factor of Reinforcement for a Member in Uniaxial Tension or Bending

Global Efficiency Factor	Woven Square Mesh	Welded Square Mesh	Hexagonal Mesh	Expanded Metal Mesh	Longitudinal Bars
Longitudinal, η_1	0.50	0.50	0.45	0.65	1
Transverse η_t	0.50	0.50	0.30	0.20	0
At 45°, $\eta_\theta = 45$	0.35	0.35	0.30	0.30	0.70

12.4.2.2 Tension

The nominal resistance of cracked ferrocement elements subject to pure tensile loading shall be approximated by the load carrying capacity of the mesh reinforcement alone in the direction of loading by the following equation:

$$N_n = A_s f_y \quad (6.12.3)$$

Where,

N_n = nominal tensile load resistance in direction considered

A_s = effective cross-sectional area of reinforcement in direction considered

f_y = yield stress of mesh reinforcement.

The value of A_s is given by

$$A_s = \sum_{i=1}^N A_{si} \quad (6.12.4)$$

Where,

N = number of mesh layers

A_{si} = effective area of reinforcement for mesh layer i .

12.4.2.3 Compression

As a first approximation, the nominal resistance of ferrocement sections subject to uniaxial compression shall be derived from the load carrying capacity of the unreinforced mortar (concrete) matrix assuming a uniform stress distribution of $0.85f'_c$ where f'_c is the design compressive strength of the mortar matrix. However, the transverse component of the

reinforcement can contribute additional strength when square or rectangular wire meshes are used. Expanded mesh contributes virtually no strengthening beyond that achieved by the mortar alone. Slenderness effects of thin sections, which can reduce the load carrying capacity below that based on the design compressive strength shall be considered.

12.4.3 Service Load Design

12.4.3.1 Flexure

For investigation of stresses at service loads, straight line theory (for flexure) shall be used with the following assumptions.

- (a) Strains vary linearly with distance from the neutral axis.
- (b) Stress strain relationships of mortar (concrete) and reinforcement are linear for stresses less than or equal to permissible service load stresses.
- (c) Mortar (concrete) resists no tension.
- (d) Perfect bond exists between steel and mortar (concrete).

To compute stresses and strains for a given loading, the cracked transformed section shall be used. The effective area of each layer of mesh reinforcement shall be determined from Eq. 6.12.2. The same value of modular ratio $n_r = E_r/E_c$, may be used for both tensile and compressive reinforcement. Recommended design values of E_r are given in Table 6.12.2. Once the neutral axis is determined, the analysis shall proceed as for reinforced concrete beams or columns having several layers of steel and subject to pure bending.

12.4.3.2 Allowable tensile stress

The allowable tensile stress in the mesh reinforcement under service conditions shall be taken as $0.60f_y$ where f_y is the yield strength. For liquid retaining and sanitary structures, the allowable tensile stress shall be limited to 200 N/mm^2 . Consideration shall be given to increase the allowable tensile stresses if crack width measurements on a model test indicate that a higher stress will not impair performance.

12.4.3.3 Allowable compressive stress

The allowable compressive stress in either the mortar (concrete) or the ferrocement composite shall be taken as $\frac{f_c}{2}$ where f_c is the specified compressive strength of the mortar. Measurements of the mortar compressive strength shall be obtained from tests on $75 \text{ mm} \times 150 \text{ mm}$ cylinders.

12.4.4 Serviceability Requirements

Ferrocement structures shall generally satisfy the intent of the serviceability requirements of Chapter 6 except for the concrete cover.

12.4.4.1 Crack width limitations

The maximum value of crack width under service load conditions shall be less than 0.10 mm for noncorrosive environments and 0.05 mm for corrosive environments and/or water retaining structures.

12.4.4.2 Fatigue stress range

For ferrocement structures to sustain a minimum fatigue life of two million cycles, the stress range in the reinforcement shall be limited to 200 N/mm². A stress range of 350 N/mm² shall be used for one million cycles. Higher values may be considered if justified by tests.

12.4.4.3 Corrosion durability

Particular care shall be taken to ensure a durable mortar matrix and optimize the parameters that reduce the risk of corrosion.

12.4.4.4 Deflection limitation

Since ferrocement in thin sections is very flexible and its design is very likely to be controlled by criteria other than deflection, no particular deflection limitation is recommended.

12.4.5 Particular Design Parameters

12.4.5.1 The cover of the reinforcement shall be about twice the diameter of the mesh wire or thickness of other reinforcement used. A smaller cover is acceptable provided the reinforcement is not susceptible to rapid corrosion, the surface is protected by an appropriate coating, and the crack width is limited to 0.05 mm. For ferrocement elements of thickness less than 25 mm, a cover of the order of 2 mm shall be provided.

12.4.5.2 For a given ferrocement cross-section of total thickness h , the mesh opening shall not be larger than h .

12.4.5.3 For nonprestressed water retaining structures the total volume fraction of reinforcement shall not be less than 3.5 percent and the total specific surface of reinforcement shall not be less than 0.16 mm²/mm³.

12.4.5.4 In computing the specific surface of the reinforcement, the contribution of fibres added to the matrix shall be considered, while the fibre contribution may be ignored in computing the volume fraction of reinforcement.

12.4.5.5 If skeletal reinforcement is used, the skeletal reinforcement shall not occupy more than 50 percent of the thickness of the ferrocement composite.

12.4.5.6 For a given volume fraction of reinforcement, better performance in terms of crack widths, water tightness, and ductility may be achieved by uniform distribution of the reinforcement throughout the thickness and by increasing its specific surface. A minimum of two layers of mesh shall be acceptable, but more than two layers of reinforcement are preferable.

12.4.6 Design Aids

The following nondimensional equation can be used to predict the nominal moment strength of ferrocement beams subjected to pure bending:

$$\frac{M_n}{f'_c b h^2 \eta} = 0.005 + 0.422(V_f f_y / f'_c) - 0.0772(V_f f_y / f'_c) \quad (6.12.5)$$

A design graph representing Eq. 6.12.5 is given in Figure 6.12.3.

12.5 Fabrication

12.5.1 General Requirements

This Section specifies the requirements for the mixing, placing, and handling of materials used in ferrocement construction.

12.5.1.1 Planning

Plastering for fabrication with ferrocement shall be continuous through the completion of the job. This requires a large number of workers involved in plastering and in maintaining a constant supply of materials during work, most often in confined work spaces. Adequate bond at cold joints may be achieved through surface roughness or treatment with bonding agents. Retarders may be useful in large time consuming plastering projects, especially in hot weather conditions. Planning for the job shall take into account all these requirements.

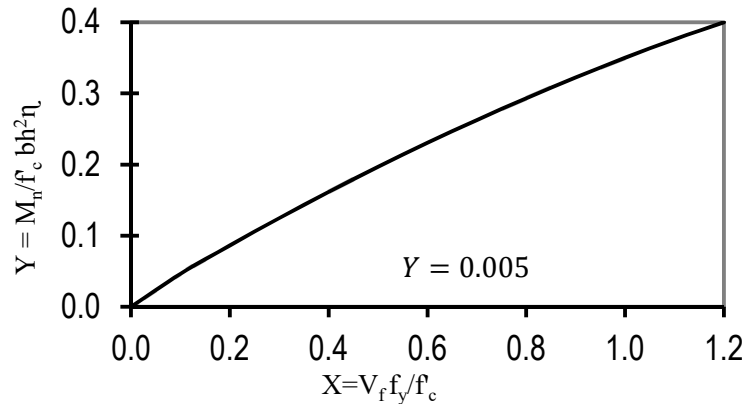


Figure 6.12.3 Chart for strength design of ferrocement in bending

12.5.1.2 Mixing

Any method, including hand mixing, which assures a homogeneous mixture of ingredients shall be satisfactory. Mixing may be accomplished in a mortar mixer with a spiral blade or paddles inside a stationary drum or in a pan type mixer. The use of rotating drum mixers with fins affixed to the sides shall not be permitted. Mix ingredients shall be carefully batched by weight, including the water, and added or charged in the mixer so that there is no caking. Mix water shall be accurately weighed so that the water cement ratio is controlled. The water cement ratio shall be as low as possible but the sand cement ratio shall be adjusted to provide a fluid mix for initial penetration of the armature followed by a stiffer more heavily sanded mix at the finish. Mortar shall be mixed in batches so that mortar is plastered within an hour after mixing. Retempering of the mortar shall be prohibited.

12.5.1.3 Mortar placement

Mortar shall generally be placed by hand plastering. In this process, the mortar is forced through the mesh. Alternatively, the mortar may be shot through a spray gun device.

12.5.1.4 Finishing

Surfaces shall be finished to assure proper cover to the last mesh layer. The surface finish shall be slightly roughened if a surface coating is to be bonded later.

Surfaces that are too smooth shall be mechanically abraded by sandblasting or other means of mechanical abrasion. Alternatively, such surfaces may be etched with phosphoric acid, provided the residue left by it will not interfere with specified finishes. Mild solutions of muriatic acid may be applied with proper attention to corrosion potential. Additional care shall be taken when plastering around openings.

12.5.1.5 Curing

Moist or wet curing is essential for ferrocement concrete construction. The low water cement ratio and high cement factors create a demand for large quantities of free water in the hydration process, and the amount permitted to evaporate into the air shall be kept to an absolute minimum. The use of fogging devices under a moisture retaining enclosure is desirable. A double layer of soaked burlap covered with polyethylene or a soaker hose may also be used. Continuous wetting of the surface or of wet burlap or the like shall be maintained to avoid dry spots. Curing shall start within a reasonable time after application of the finishing layer.

12.5.2 Construction Methods

All methods shall have high level quality control criteria to achieve the complete encapsulation of several layers of reinforcing mesh by a well compacted mortar or concrete matrix with a minimum of entrapped air. The most appropriate fabrication technique shall be decided on the basis of the nature of the particular ferrocement application, the availability of mixing, handling, and placing machinery, and the skill and cost of available labour. Several recommended construction methods are outlined in the following subsections.

12.5.2.1 Armature system

The armature system is a framework of tied reinforcing bars (skeletal steel) to which layers of reinforcing mesh are attached on each side. Mortar is then applied from one side and forced through the mesh layers towards the other side, as shown in Figure 6.12.4.

The skeletal steel can assume any shape. Diameter of the steel bars depends on the size of the structure. Skeletal steel shall be cut to specified lengths, bent to the proper profile, and tied in proper sequence. Sufficient embedment lengths shall be provided to ensure continuity. For bar sizes 6 mm or less, lap lengths from 230 to 300 mm may be sufficient. The required number of layers of mesh shall be tied to each side of the skeletal steel frame.

12.5.2.2 Closed-mould system

The mortar is applied from one side through several layers of mesh or mesh and rod combinations that have been stapled or otherwise held in position against the surface of a closed mould, i.e. a male mould or a female mould. The mould may remain as a permanent part of the finished ferrocement structure. If removed, treatment with release agents may be needed. The use of the closed mould system represented in Figure 6.12.5 tends to eliminate the use of rods or bars, thus permitting an essentially all mesh reinforcement. It requires that plastering be done from one side only.

12.5.2.3 Integral-mould system

An integral mould is first constructed by application of mortar from one or two sides onto a semi-rigid framework made with a minimum number of mesh layers. This forms, after mortar setting, a rigid but low quality ferrocement mould onto which further layer of reinforcing mesh and mortar shall be applied on both sides. Alternatively, the integral mould may be formed using rigid insulation materials, such as polystyrene or polyurethane, as the core. A schematic description of this system is given in Figure 6.12.6.

12.5.2.4 Open-mould system

In the open-mould system, mortar is applied from one side through layers of mesh or mesh and rods attached to an open mould made of a lattice of wood strips. The form, Figure 6.12.7, is coated with a release agent or entirely covered with polyethylene sheeting (thereby forming a closed but nonrigid and transparent mould) to facilitate mould removal and to permit observation and/or repair during the mortar application process.

This system is similar to the closed-mould system in which the mortar is applied from one side, at least until the mould can be removed. It enables at least part of the underside of the mould to be viewed and repaired, where necessary, to ensure complete and thorough impregnation of the mesh.

12.6 Maintenance

12.6.1 General

Terrestrial structures are susceptible to deterioration from pollutants in ground water and those that precipitate from the air (acid rain). Environmental temperature and humidity variations also affect ferrocement durability and maintenance procedures.

Maintenance shall involve detecting and filling voids, replacing spalled cover, providing protective coatings, and cosmetic treatment of surface blemishes. Due to the thin cover in ferrocement, muriatic acid (hydrochloric acid) shall be used with extreme caution. Phosphoric acid and other nonchloride cleaners shall be the specified alternative (see Sec 12.5.1.4).

Repairs not involving large quantities of materials shall be accomplished by hand. Emphasis shall be placed on the ability of the repair material to penetrate the mesh cage, to fully coat the reinforcing to inhibit corrosion, and to bond to the substrate. Rapid set and strength gain shall be the overriding considerations for emergency repairs. Protective coatings shall bond well and be alkali tolerant, thermally compatible, and resistant to environmental pollutants and ultraviolet radiation, if exposed.

12.6.2 Blemish and Stain Removal

12.6.2.1 General

Since ferrocement is usually less porous than conventional concrete, stains do not penetrate very deep in the mortar matrix. Care shall be taken when preparing the surface not to diminish the thin cover of mortar over ferrocement reinforcement.

12.6.2.2 Construction blemishes

Construction blemishes are often caused by improper selection or use of materials, faulty workmanship, uneven evaporation, and uneven curing. Care shall be exercised to minimize these and the following causes of blemishes in ferrocement.

- (a) Cement from different mills will cause colour variation, although most of the colour in mortar is due to the sand component. Where appearance is critical, care shall be taken to obtain sand from a single source and have it thoroughly washed.
- (b) Mottling results from the use of calcium chloride or high alkali cement combined with uneven curing.
- (c) The use of polyethylene sheet material to cover surfaces promotes uneven curing.
- (d) The water cement ratio affects tone and surface appearance. Low water cement ratio will result in a darker appearance.
- (e) Hard steel toweling densifies the surface, causing more rapid drying and also leaving a darkened surface.

12.6.2.3 Stain removal

Treatment of stains shall be done promptly after discoloration appears. Thorough flushing and brushing with a stiff bristle brush and detergent is the first approach. If this is ineffective, a dilute (about three percent) solution of phosphoric or acetic acid shall be applied. Another chemical treatment that may be considered safe and effective is a 20 to 30 percent solution of di-ammonium citrate, a mild acid that attacks calcium carbonates and calcium hydroxides. This treatment makes the surface more porous and promotes hydration.

When a stain has penetrated too deeply to be removed by surface chemical application and scrubbing, a poultice or a bandage may be needed. A poultice is intended to dissolve the stain and absorb it into the poultice. The poultice is made by mixing one or more chemicals such as a solution of phosphoric acid with a fine inert power such as talc, whiting, hydrated

lime, or diatomaceous earth to form a paste. The paste is spread in a thick layer over the stain and allowed to dry. A bandage may consist of a few layers of cloth or paper toweling soaked in a chemical solution. More than one application of a poultice or bandage may be needed for stubborn stains.

Caution:

Most of the chemicals used to remove stains are toxic and require safeguards against skin contact and inhalation. Whenever acids are used, surfaces shall first be saturated with water or the dissolved stain material may migrate deeper into the concrete and reappear at a later date as efflorescence.

12.6.2.4 Efflorescence:

Efflorescence is caused by deposition of salts on the surface due to the evaporation of migrating water bearing salts from within ferrocement; it is typically associated with a porous ferrocement. Water cement ratio shall be limited to within 0.4 and the mortar well compacted to minimize efflorescence. Voids, if present, may be treated by breaking into with a hammer and replastering. Alternatively, voids may be drilled into with a masonry bit and repaired by injecting a non-shrinking cement grout.

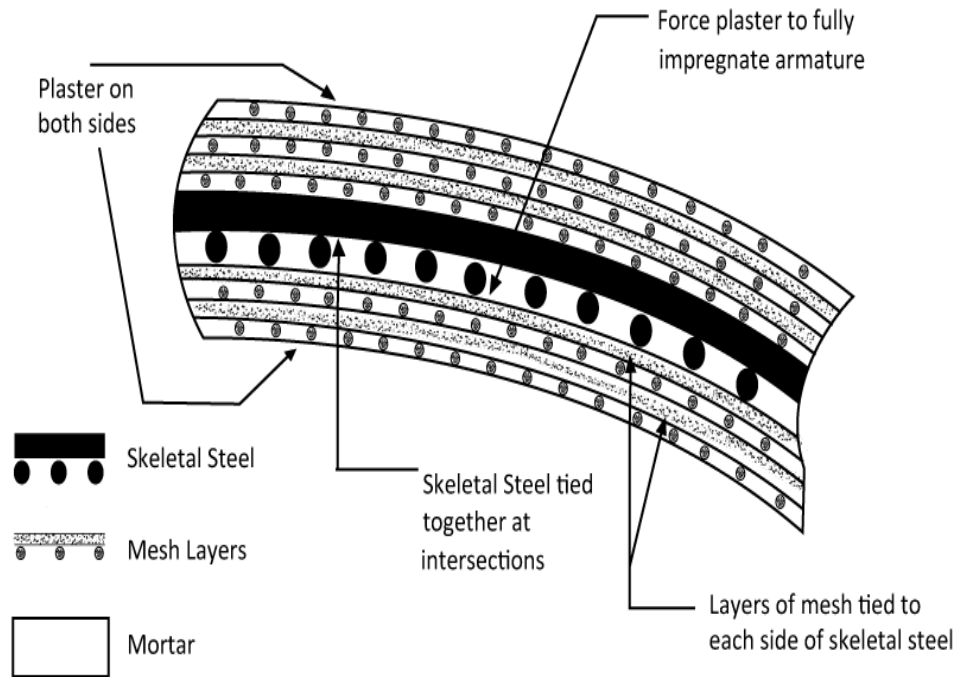


Figure 6.12.4 Armature system

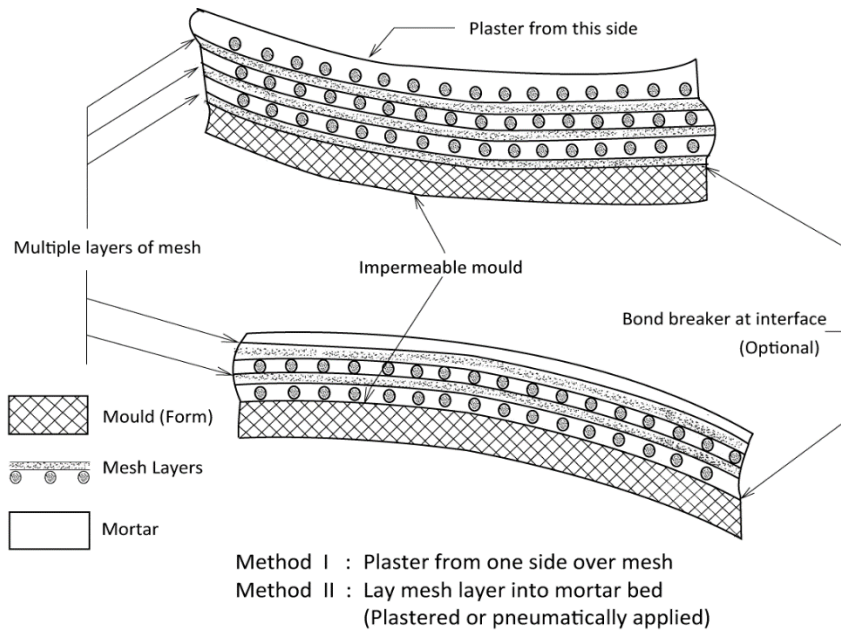


Figure 6.12.5 Closed-mould System

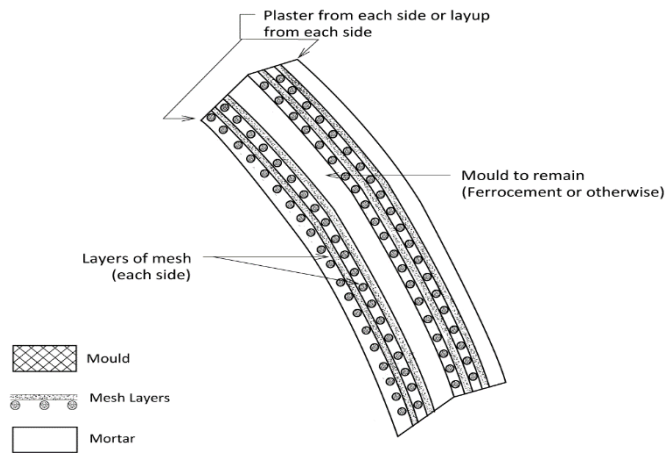


Figure 6.12.6 Integral-mould System

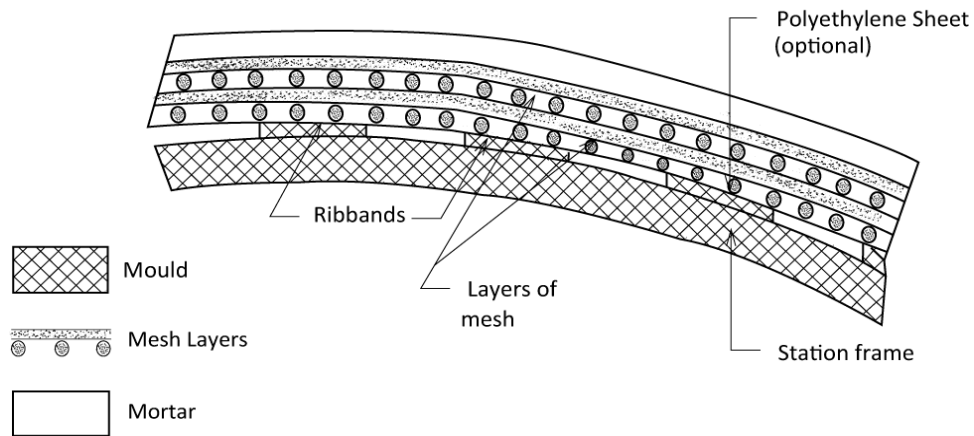


Figure 6.12.7 Open-mould System

12.6.3 Protective Surface Treatments

12.6.3.1 General

Good quality mortar has excellent resistance to weathering. The application of protective surface treatments can improve the performance of ferrocement and extend its useful service life. Surface treatments shall be used to improve appearance, harden the surface, and reduce permeability, thus guarding against the corrosive action of acids, alkaline salts, and organic substances.

12.6.3.2 Hardeners

Hardeners may be used to protect the ferrocement surface or to seal and prepare it for application of paints. When a sodium silicate hardener is used, it shall be diluted with water. The actual proportion of water to be used shall depend on the manufacturer's recommendation. The hardener shall be applied in multiple coats with the first coat being more dilute than the subsequent ones. Each coat must be completely dry before the next coat is applied.

Other hardeners that seal and prepare the surface for application of oil base paints are magnesium fluorosilicate and zinc fluorosilicate. The treatment shall consist of two or more applications. A solution containing about 1 kg of fluorosilicate crystals per 10 litres of water shall be used for the first application; and a solution containing 2.4 kg per 10 litres of water shall be used for subsequent applications. After the last application has dried, the surface shall be brushed and washed with water to remove any crystals that may have formed.

12.6.3.3 Coatings

When resistance to abrasion is desired, ferrocement surfaces may be coated with polyurethanes, especially those furnished in two part mixtures. Coatings formulated from acrylics may be used to provide resistance to sunlight and weathering. Water based acrylic

latex house paints may be used for application to damp surfaces. For any surface opposite a surface sealed with an impermeable coating, an acrylic coating formulated to allow the escape of water vapour shall be specified.

12.7 Damage Repair

12.7.1 Common Types of Damage

Ferrocement structures shall be inspected, as part of a regular maintenance programme, to detect any of the following types of damage. Appropriate repair measures shall then be taken.

12.7.1.1 Delaminations

Delaminations occur when ferrocement splits between layers in laminated constructions due to springing back or bridging of the mesh during construction. Delamination sometimes occurs at or near the neutral axis under impact or flexure when there are many voids in the interior layers. Such areas give off a hollow sound when tapped with a hammer or stroked with a steel bar.

12.7.1.2 Spalls

A spall is defined as a depression resulting when a fragment is detached from a larger mass by a blow, by the action of weather, by pressure, or by expansion within the mass. Spalls shall be considered large when their size exceeds approximately 20 mm in depth or 150 mm in any dimension, and shall be repaired by replastering.

Spalls are usually caused by corrosion of steel, which causes an expansive pressure within the ferrocement. Chlorides in the concrete greatly increase the potential for corrosion of the steel. Under such conditions, continued spalling is likely and the repair of local spall areas may even promote the deterioration of the concrete because of the presence of dissimilar materials.

An area of steel corrosion and chloride contaminated concrete may be considerably larger than the area of spalled concrete, and the full area of contamination rather than the spall itself shall be broken and replastered.

12.7.1.3 Fire damage

Ferrocement may be more susceptible to fire damage than conventional concrete because of the thin cover. If the fire were intense enough to release the amount of chemically bound water in the cement, destroy the bond between the cement and the aggregate, or oxidize the reinforcement, the surface would be charred and spalled so that the damage could be easily identified. Full scale removal and repair shall then be required.

12.7.1.4 Cracks and local fractures

Hairline cracks and crazing due to temperature changes or drying shrinkage in the cover coat do not require repair. Continuous wet curing will cause autogenous healing, and a flexible coating will conceal the crack from view. If cracks are caused by continuing overloads or are due to structural settlement and the cause cannot be removed, replacement or a structural overlay shall be required. Cracks due to occasional impact or overload may be repaired. Local fractures are cracks in which displacement of section has occurred as a result of impact.

12.7.2 Evaluation of Damage

12.7.2.1 Evaluation of damage shall take into consideration its extent, cause, and likelihood of the cause still being active. The method of repair shall be dictated by the type of damage, the availability of special equipment and repair materials, and the level of skill of the workers employed. Economic factors may influence the decision as to whether the repair shall be extensive and permanent, or limited in scope in response to an immediate problem.

12.7.2.2 Repair materials shall bond to the original structure, resist pollutants in the surrounding soil, water or air, and respond the same way to changes in temperature, moisture, and loads. Removal of deteriorated or chloride contaminated mortar trapped within the reinforcing mesh requires a large amount of hand labour, so it may be economical (and better for long term durability) to reconstruct or replace an entire area using the original structure as a form that can be left in place or removed after the overlaid structure has cured. Complete reconstruction shall be undertaken when chloride contamination, mesh corrosion, and deterioration of the mortar are extensive.

12.7.2.3 Testing for damage in ferrocement may be done by tapping with a hammer to break into any voids under the surface, or by drawing a metal bar over the surface and listening for sounds indicating voids or the presence of deteriorated concrete. A high quality ferrocement should produce a bell like sound and resist moderately severe hammer blows without damage.

12.7.3 Surface Preparation for Repair of Damage

12.7.3.1 General

The primary objective is to remove any deteriorated mortar or mortar contaminated with corrosive agents and to provide a surface to which the repair materials can be bonded properly. The rougher the surface, the greater is the area available for bonding.

12.7.3.2 Removal of deteriorated concrete

As a first step in any repair all disintegrated, unsound, and contaminated mortar shall be removed. Saws and chipping hammers used for conventional concrete shall not be used for ferrocement unless large sections are to be completely removed.

Small areas shall be prepared by hand hammering just hard enough to pulverize deteriorated or cracked mortar, but not to the point of damaging the reinforcing mesh.

A pneumatic needle gun may be used for cleaning out broken ferrocement, opening out cracks, and roughening the surface.

Particles of sound mortar embedded in the mesh need not be removed provided they are small enough not to interfere with the penetration of new mortar and they will not project from the finished surface.

12.7.3.3 Reinforcement

Any loose, scaly corrosion revealed on cleaning out the mortar shall be removed by sandblasting, water jet, air blasting, or vacuum methods.

An alternative method for removing rust is to brush naval jelly or spray dilute phosphoric acid over the repair area and flush thoroughly.

Where the mesh cage has been displaced but is still intact, it may be pushed or jacked back in place and supported securely to withstand the pressure of applying the repair material. Where the reinforcement has been torn, the old mesh shall be laced back to close the opening.

When rods supporting the mesh cage are torn they shall be spliced by a 15 diameter overlap of the partner rod or anchored by hooks.

12.7.3.4 Cleaning

Loose particles and dust residue from hammering or sandblasting shall be air jetted or vacuum cleaned if epoxy or methymethacrylate (MMA) is the repair material. Water jetting may be used if the repair is to be made with hydraulic cement or latex modified mortar.

If an air jet is used, the compressor shall be equipped with an oil trap to prevent contamination of the surface. Surface oil or dirt shall be removed by trisodium phosphate or other strong detergents.

12.7.3.5 Cracks

Cracks may be cleaned by hammering out the mortar on each side of the crack and replastered with latex mortar.

If opening the crack is not feasible, epoxy or MMA injection systems shall be attempted in accordance with the product directions. The crack shall be cleaned first with oil free compressed air, and small (about 2 to 3 mm) drill holes shall be made at the highest and lowest points in the crack. The surface between the holes shall be sealed with strong coatings or a pressure pad. Catalyzed epoxy or MMA shall be injected at the lower hole until it comes out at the upper hole. Where latex cement grout is to be used, the interior of the crack shall be thoroughly saturated with water and allowed to drain.

12.7.4 Repair Materials

12.7.4.1 Portland cement and sand

Portland cement used for repair shall conform to the requirements of Sec 12.3.1.

Sand which matches that used in the original construction may be used unless the need for the repair arose because of reactive or contaminated sand. Neat Portland or blended cement paste shall be used to fill small cracks, and a mortar with fine sand shall be used to fill larger cracks or voids. Both shall be used in combination with latex for thin patches and overlays. Larger cracks shall be coated with neat cement slurry, and then dry packed with a very low water cement ratio mortar.

The addition of latex to Portland cement mortar markedly improves bond to the substrate and the tensile strength of the patch. Of the synthetic latexes, polyvinyl acetate and polyvinylidene are unsuitable for wet environments. Acrylics may be used as admixtures to improve bonding and as curing compounds. Acrylic latex in concentrated form shall be diluted to 10 to 20 percent solids and then used as the mixing water for the mortar. Latex mortars may be applied to a damp surface, but the patch shall be allowed to dry thoroughly before being immersed in water.

12.7.4.2 Polymer mortars

Nonlatex polymer mortars shall require the use of surface dried and, preferably, oven dried sand. The monomers have very low viscosity and so shall be mixed with thickening agents to be placed in any area that cannot be sealed tightly. Epoxy resins that are moisture tolerant may be used on damp surfaces.

Care shall be exercised in applying polymers or the promoters and hardeners used with them which are toxic.

12.7.4.3 Admixture

Accelerators may be employed where cement alone is the repair material. Since chloride compounds may promote corrosion, nonchloride accelerators shall be preferred for all ferrocement. Emergency repairs of small areas below the waterline with hot plug, which is neat cement moistened to a putty consistency with a concentrated solution of calcium chloride may be permitted. The hot plug may be carried in the hand or in a plastic bag to the site of the leak, pressed into the hole, and held a few minutes until set. Permanent repair shall be accomplished as soon as possible using materials without chlorides.

12.7.5 Repair Procedure

12.7.5.1 Mixing

Small quantities of materials required for ferrocement repairs may be hand mixed on flat surface or in a tray using premixed dry ingredients. For large quantities, a plaster or pan mixer rather than a rotating drum type mixer shall be used. For machine mixing water shall be put in first; then the cement, to form slurry; then the pozzolan, if used; and finally, enough sand to bring the mortar to the desired degree of workability.

The consistency of the mortar shall be selected according to the nature of the repair. A slurry of cream consistency shall be used first to paint the moistened edges of the repair area, fill cracks or small voids, and thoroughly coat all the interior mesh and rods. After this, more sand shall be added until the mortar is stiff enough to hold its shape when brought out flush with the finished surface.

To avoid excessive amounts of entrained air, mortars containing acrylics or epoxies shall not be mixed longer than two minutes. They shall be applied within thirty minutes of mixing.

12.7.5.2 Full depth repair

When both faces are accessible, a fluid mortar shall be pushed through the mesh cage from one side until an excess appears on the opposite face. This excess shall then be pushed back and finished flush. A vibrating float or trowel may be used to place and finish a very stiff mortar. Pencil type vibrators shall not be used.

12.7.5.3 Partial depth patches

The area to be patched shall first be saturated with water, then air blown or blotted free of standing water until only surface-moist. Cement slurry of not more than 0.4 water cement ratio and of paint like consistency shall be brushed over the whole area and into any

openings in the mesh. This shall be immediately followed by a heavily sanded mortar of the same water cement ratio, which shall be vibrated or tamped into the patch and finished flush.

12.7.5.4 Overlays

The substrate shall be prepared in the manner prescribed in Sec 12.7.5.3 for patches. The old surface shall be thoroughly cleaned or scarified by mechanical means and the repair materials shall match the thermal characteristics of the substrate.

Chemical etching shall be followed by mechanical abrasion, unless the surface is flushed with high pressure water jet equipment.

For thin overlays, velocity placement such as spritzing or casting by hand, and shotcreting, shall be used.

12.7.5.5 Shotcrete

Shotcrete may be used in ferrocement repair when a large area is involved. Small, low cost portable plaster pumps operating on the Moyno progressive cavity principle with a rotor inside a stator tube shall be adequate for both original ferrocement construction and repair.

Shotcrete or plastering equipment may be used for large overlays incorporating additional layers of reinforcing mesh by laminating techniques. Existing surfaces shall be scarified or sandblasted, then saturated with water and allowed to damp dry just before the shotcrete or mortar spray is applied. An initial application of cement slurry is not needed with shotcrete but a latex or wet to dry epoxy bonding compound may be used to advantage with repairs made with plastering equipment.

12.7.5.6 Curing

All Portland cement patches and overlays shall be thoroughly cured unless latex compounds are used to seal the surface and furnish water for hydration. Curing shall be instituted immediately for thin patches and overlays. Several layers of paper or cloth soaked in water and covered with a plastic sheet that is well secured at the edges may be used on patches. A full plastic film covering overlays may be used but it may produce discoloration where it touches the surface.

12.8 Testing

12.8.1 Test Requirement

Tests and observations that are commonly made during the design, construction, and subsequent service life of concrete structures shall also be applicable to ferrocement structures. The test programme shall include

- (a) tests on physical, chemical and mechanical properties of the ferrocement ingredients, such as water purity, sieve analysis, mesh strength etc.,
- (b) control tests for fresh mortar mix, such as slump, air content etc.,
- (c) tests on the mechanical properties of the hardened ferrocement, such as bending, cracking and fatigue strengths, permeability etc., and
- (d) in-service condition tests, such as potential for corrosion, cracking, durability etc.

For predicting the mechanical properties of ferrocement, the tests specified in Sections 12.8.2.1 to 12.8.2.4 shall be conducted.

12.8.2 Test Methods

12.8.2.1 Compressive strength and static modulus of elasticity of mortar

The compressive strength and static modulus of elasticity of the mortar used for the fabrication of ferrocement shall be determined from 75 mm x 150 mm cylinders tested in accordance with ASTM C39 and C469, respectively.

12.8.2.2 Flexural strength of ferrocement

Ferrocement specimens shall be tested as a simply supported beam with third point loading. The span to depth ratio of the beam specimen shall not be less than 20 and its width shall not be less than six times the mesh opening or wire spacing measured at right angles to the span direction.

12.8.2.3 Tensile properties of the mesh reinforcement

Square or rectangular meshes may be tested directly in tension; hexagonal meshes and expanded metal meshes shall be tested only while encapsulated in mortar. In the latter case

the tensile test shall be performed on the ferrocement material as described in Sec 12.8.2.4 below.

For square and rectangular meshes, the yield strength, elastic modulus, and ultimate tensile strength shall be obtained from direct tensile tests on samples of wires or flat coupons cut from the mesh. The test shall be in accordance with the following guidelines (see also Figure 6.12.8).

- (a) The test specimen shall be prepared by embedding both ends of a rectangular coupon of mesh in mortar over a length at least equal to the width of the sample. The mortar embedded ends shall serve as pads for gripping. The free (not embedded) portion of the mesh shall represent the test sample.
- (b) The width of the test sample shall be not less than six times the mesh opening or wire spacing measured at right angles to the loading direction.
- (c) The length of the test sample shall be not less than three times its width or 150 mm, whichever is larger.
- (d) Measurements of elongations (from which strains are to be computed) shall be recorded over half the length of the mesh sample.
- (e) Yield strain of mesh reinforcement shall be taken as the strain at the intersection of the best straight line fit of the initial portion of the stress strain curve and the best straight line fit of the yielded portion of the stress strain curve, as shown in Figure 6.12.8. The yield stress shall be taken as the stress point on the original stress strain curve at the yield strain found above. The procedure is demonstrated in Figure 6.12.8.

12.8.2.4 Tensile Test of Ferrocement:

Direct tensile tests of ferrocement elements shall be made using rectangular specimens satisfying the same minimum size requirement as those set in Sec 12.8.2.3 for the mesh reinforcement. The test specimens shall be additionally reinforced at their ends for gripping. The middle half of the nongripped (free) portion of the test specimen shall be instrumented to record elongations. A plot of the load elongation curve up to failure shall be used to estimate the effective modulus of the mesh system as well as its yield strength,

ultimate strength, and efficiency factor. The yield strain and corresponding stress shall be determined in accordance with the procedure described in Sec 12.8.2.3.

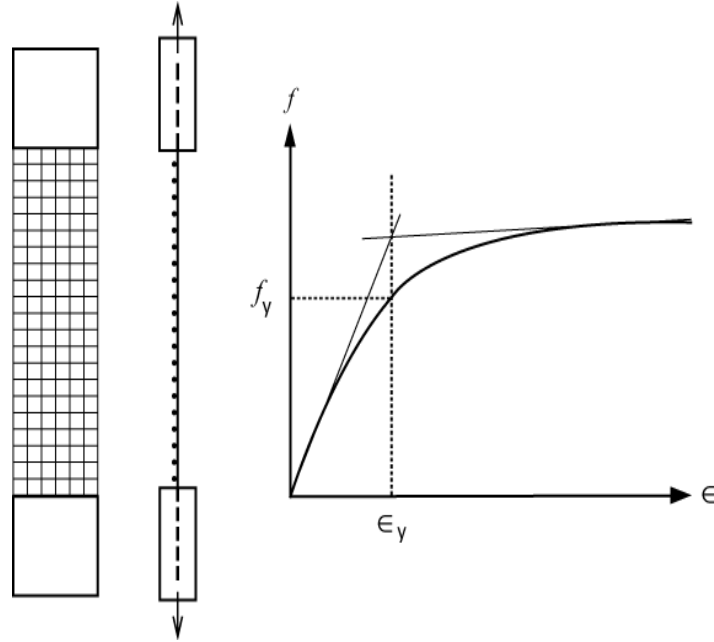


Figure 6.12.8 Schematic description of mesh tensile test sample and corresponding stress-strain curve

12.9 Related Appendix

Appendix U Volume Fraction of Reinforcement and Types of Steel Meshes Used in Ferrocement

PART VI
Chapter 13
Steel-Concrete Composite Structural Members

13.1 General

This Section states the scope of the specification, summarizes referenced specifications, codes and standard documents and provide requirements for materials for steel-concrete composite members. General provisions for composite sections and shear connectors are also included.

13.1.1 Scope

The guidelines included in Chapter 13 of part 6 of this Code presents the design guidelines for steel concrete composite members frequently used in medium to high rise buildings. This Chapter mainly addresses composite columns composed of rolled or built-up structural steel shapes or HSS, and structural concrete acting together, and steel beams supporting a reinforced concrete slab so interconnected that the beams and the slab act together to resist bending. Simple and continuous composite beams with shear connectors and concrete-encased beams, constructed with or without temporary shores, are included. Seismic provisions for steel-concrete composite members are also provided.

13.1.2 Material Limitations

Concrete and steel reinforcing bars in composite systems shall be subject to the following limitations.

- (a) For the determination of the available strength, concrete shall have a compressive strength f'_c of not less than 21 MPa nor more than 70 MPa for normal weight concrete and not less than 21 MPa nor more than 42 MPa for lightweight concrete.
- (b) The specified minimum yield stress of structural steel and reinforcing bars used in calculating the strength of a composite column shall not exceed 525 MPa.

Higher material strengths are permitted when their use is justified by testing or analysis.

13.1.3 General Provisions

In determining load effects in members and connections of a structure that includes composite members, consideration shall be given to the effective sections at the time each increment of load is applied. The design, detailing and material properties related to the concrete and reinforcing steel portions of composite construction shall comply with the reinforced concrete and reinforcing bar design specifications stipulated by the provisions in Part 6 Chapter 6.

13.1.3.1 Resistance prior to composite action

The factored resistance of the steel member prior to the attainment of composite action shall be determined in accordance with Chapter 10 Part 6.

13.1.3.2 Nominal strength of composite sections

Two methods are provided for determining the nominal strength of composite sections: the plastic stress distribution method and the strain-compatibility method. The tensile strength of the concrete shall be neglected in the determination of the nominal strength of composite members.

13.1.3.2.1 Plastic stress distribution method

For the plastic stress distribution method, the nominal strength shall be computed assuming that steel components have reached a *stress* of F_y in either tension or compression and concrete components in compression have reached a *stress* of $0.85f'_c$. For round *HSS* filled with concrete, a *stress* of $0.95f'_c$ is permitted to be used for concrete components in uniform compression to account for the effects of concrete confinement.

13.1.3.2.2 Strain-compatibility method

For the strain compatibility method, a linear distribution of strains across the section shall be assumed, with the maximum concrete compressive strain equal to 0.003 mm/mm (in/in). The stress-strain relationships for steel and concrete shall be obtained from tests or from published results for similar materials.

13.1.3.2.3 Shear connectors

Shear connectors shall be headed steel studs not less than four stud diameters in length after installation, or hot-rolled steel channels. Shear stud design values shall be taken as per Sections 13.2.1.7 and 13.3.2.4. Stud connectors shall conform to the requirements of Sec 13.3.2.4(3) Channel connectors shall conform to the requirements of Sec 13.3.2.4(4).

13.2 Design of Composite Axial Members

This section states the design guidelines for two types of composite axial members. These include—encased composite columns and concrete filled hollow structural sections.

13.2.1 Encased Composite Columns

13.2.1.1 Scope

This section applies to doubly symmetric steel columns encased in concrete, provided that

- the steel shape is a compact or non-compact section
- the cross-sectional area of the steel core comprises at least 1 percent of the total composite cross section
- concrete encasement of the steel core is reinforced with continuous longitudinal bars and lateral ties or spirals. The minimum transverse reinforcement shall be at least 6 mm² per mm of tie spacing
- The minimum reinforcement ratio for continuous longitudinal reinforcing, ρ_{SR} , shall be 0.004, where ρ_{SR} is given by:

$$\rho_{SR} = \frac{A_{SR}}{A_g} \quad (6.13.1)$$

Where,

A_{SR} = area of continuous reinforcing bars, mm²

A_g = gross area of composite member, mm²

13.2.1.2 Compressive strength

The design compressive strength, $\phi_c P_n$, and allowable compressive strength, P_n/Ω_c , for axially loaded encased composite columns shall be determined for the limit state of flexural buckling based on column slenderness as follows:

$$\phi_c = 0.75 \text{ (LRFD)} \quad \Omega_c = 2.00 \text{ (ASD)}$$

- When, $P_e \geq 0.44P_o$

$$P_n = P_o \left[0.658^{\left(\frac{P_o}{P_e}\right)} \right] \quad (6.13.2)$$

- When, $P_e < 0.44P_o$

$$P_n = 0.877P_e \quad (6.13.3)$$

Where,

$$P_o = A_s F_y + A_{sr} F_{yr} + 0.85 A_c f'_c \quad (6.13.4)$$

$$P_e = \frac{\pi^2 (EI_{eff})}{(KL)^2} \quad (6.13.5)$$

And where,

A_s = area of the steel section, mm²

A_c = area of concrete, mm²

A_{sr} = area of continuous reinforcing bars, mm²

E_c = modulus of elasticity of concrete = $0.043 w_c^{1.5} \sqrt{f'_c}$ MPa

E_s = modulus of elasticity of steel = 210 GPa

f'_c = specified compressive strength of concrete, MPa

F_y = specified minimum yield stress of steel section, MPa

F_{yr} = specified minimum yield stress of reinforcing bars, MPa

I_c = moment of inertia of the concrete section, mm⁴

I_s = moment of inertia of steel shape, mm⁴

I_{sr} = moment of inertia of reinforcing bars, mm⁴

K = the effective length factor determined in accordance with Chapter 10
Part 6

L = laterally unbraced length of the member, mm

w_c = weight of concrete per unit volume $1500 \leq w_c \leq 2500$ kg/m³

Where,

EI_{eff} = effective stiffness of composite section, N-mm²

$$EI_{eff} = E_s I_s + 0.5 E_s I_{sr} + C_1 E_c I_c \quad (6.13.6)$$

Where,

$$C_1 = 0.1 + 2 \left(\frac{A_s}{A_c + A_s} \right) \leq 0.3 \quad (6.13.7)$$

13.2.1.3 Tensile strength

The design tensile strength, $\phi_t P_n$, and allowable tensile strength, P_n/Ω_t , for encased composite columns shall be determined for the limit state of yielding as

$$P_n = A_s F_y + A_{sr} F_{yr} \quad (6.13.8)$$

$$\phi_t = 0.90 \text{ (LRFD)} \quad \Omega_t = 1.67 \text{ (ASD)}$$

13.2.1.4 Shear strength

The available shear strength shall be calculated based on either the shear strength of the steel section alone as specified in Sec 10.7, plus the shear strength provided by tie reinforcement, if present, or the shear strength of the reinforced concrete portion alone.

13.2.1.5 Load transfer

Loads applied to axially loaded encased composite columns shall be transferred between the steel and concrete in accordance with the following requirements:

- (a) When the external force is applied directly to the steel section, shear connectors shall be provided to transfer the required shear force, V' , as follows:

$$V' = V \left(1 - \frac{A_s F_y}{P_o} \right) \quad (6.13.9)$$

Where

V = required shear force introduced to column, N

A_s = area of steel cross section, mm²

P_o = nominal axial compressive strength without consideration of length effects, N

- (b) When the external force is applied directly to the concrete encasement, shear connectors shall be provided to transfer the required shear force, V' , as follows:

$$V' = V \left(\frac{A_s F_y}{P_o} \right) \quad (6.13.10)$$

- (c) When load is applied to the concrete of an encased composite column by direct bearing the design bearing strength, $\phi_B P_p$, and the allowable bearing strength, P_p/Ω_B , of the concrete shall be:

$$P_p = 1.7f'A_B \quad (6.13.11)$$

Where,

$$\phi_B = 0.65 \text{ (LRFD)} \quad \Omega_B = 2.31 \text{ (ASD)}$$

Where,

A_B = loaded area of concrete, mm²

13.2.1.6 Detailing requirements

13.2.1.6.1 Longitudinal bars

The concrete encasement shall be reinforced with longitudinal bars and lateral ties extending completely around the structural steel core. The clear cover shall not be less than 40 mm.

The longitudinal bars shall

- (a) Be continuous at framed levels when considered to carry load;
- (b) Have an area not less than 0.01 times the total gross cross-sectional area;
- (c) Be located at each corner; and
- (d) Spaced on all sides not further apart than $525t/f_y$, times one-half the least dimension of the composite section.

13.2.1.6.2 Lateral ties

The lateral ties shall

- (a) Be 15M bars, except that 10M bars may be used when no side dimension of the composite section exceeds 500 mm; and
- (b) Have a vertical spacing not exceeding the least of the following:
 - (i) Two-thirds of the least side dimension of the cross-section;
 - (ii) 16 longitudinal bar diameters; or
 - (iii) 500 mm.

Where required, shear connectors transferring the required shear force shall be distributed along the length of the member at least a distance of 2.5 times the width of a rectangular HSS or 2.5 times the diameter of a round HSS both above and below the load transfer region. The maximum connector spacing shall be 405 mm.

13.2.1.6.3 Shear connectors

Shear connectors shall be provided to transfer the required shear force Section specified in Sec 13.2.2.5. The shear connectors shall be distributed along the length of the member at least a distance of 2.5 times the depth of the encased composite column above and below the load transfer region. The maximum connector spacing shall be 405 mm. Connectors to transfer axial load shall be placed on at least two faces of the steel shape in a configuration symmetrical about the steel shape axes.

13.2.1.6.4 Columns with multiple built-up shapes

If the composite cross section is built up from two or more encased steel shapes, the shapes shall be interconnected with lacing, tie plates, batten plates or similar components to prevent buckling of individual shapes due to loads applied prior to hardening of the concrete.

13.2.1.7 Strength of stud shear connectors

The nominal strength of one stud shear connector embedded in solid concrete is:

$$Q_n = 0.5A_{sc}\sqrt{f'_c E_c} \leq A_{sc}F_u \quad (6.13.12)$$

Where,

A_{sc} = cross-sectional area of stud shear connector, mm²

F_u = specified minimum tensile strength of a stud shear connector, MPa

13.2.2 Concrete Filled Hollow Structural Section

13.2.2.1 Scope

Section 13.2.2 applies to composite members consisting of steel hollow structural sections (HSS) completely filled with concrete, provided that

- The cross-sectional area of the steel HSS shall comprise at least 1 percent of the total composite cross-section.
- The width-to-thickness ratio of the walls of rectangular hollow structural sections does not exceed $\frac{1350}{\sqrt{F_y}}$.
- The outside diameter-to-thickness ratio of circular hollow structural sections does not exceed $\frac{28000}{F_y}$.
- The concrete strength is between 20 and 80 MPa for axially loaded columns and between 20 and 40 MPa for columns subjected to axial compression and bending.

13.2.2.2 Compressive strength

The design compressive strength, $\phi_c P_n$ and allowable compressive strength, P_n/Ω_c , for axially loaded filled composite columns shall be determined for the limit state of flexural buckling based on Section 13.2.1.2 with the following modifications:

$$P_o = A_s F_y + A_{sr} F_{yr} + C_2 A_c f'_c \quad (6.13.13)$$

$C_2 = 0.85$ for rectangular sections and 0.95 for circular sections

$$EI_{eff} = E_s I_s + E_s I_{sr} + C_3 E_c I_c \quad (6.13.14)$$

$$C_3 = 0.6 + 2 \left(\frac{A_s}{A_c + A_s} \right) \leq 0.9 \quad (6.13.15)$$

13.2.2.3 Tensile strength

The design tensile strength, $\phi_t P_n$, and allowable tensile strength, P_n/Ω_t for filled composite columns shall be determined for the limit state of yielding as:

$$P_n = A_s F_y + A_{sr} F_{yr} \quad (6.13.16)$$

$$\phi_t = 0.90 \text{ (LRFD)} \quad \Omega_t = 1.67 \text{ (ASD)}$$

13.2.2.4 Shear strength

The available shear strength shall be calculated based on either the shear strength of the steel section alone as specified in Chapter 10 or the shear strength of the reinforced concrete portion alone. The shear strength of reinforced concrete portion may be determined according to Chapter 6 of Part 6.

13.2.2.5 Load transfer

Loads applied to filled composite columns shall be transferred between the steel and concrete. When the external force is applied either to the steel section or to the concrete infill, transfer of force from the steel section to the concrete core is required from direct bond interaction, shear connection or direct bearing. The force transfer mechanism providing the largest nominal strength may be used. These force transfer mechanisms shall not be superimposed.

When load is applied to the concrete of an encased or filled composite column by direct bearing the design bearing strength, $\phi_B P_p$, and the allowable bearing strength, P_p/Ω_B , of the concrete shall be:

$$P_p = 1.7f'_c A_E \quad (6.13.17)$$

$$\phi_B = 0.65 \text{ (LRFD)} \quad \Omega_B = 2.31 \text{ (ASD)}$$

Where, A_E is the loaded area, mm².

13.2.2.6 Detailing requirements

Where required, shear connectors transferring the required shear force shall be distributed along the length of the member at least a distance of 2.5 times the width of a rectangular HSS or 2.5 times the diameter of a round HSS both above and below the load transfer region. The maximum connector spacing shall be 405 mm.

13.3 Design of Composite Flexural Members

This section applies to composite beams consisting of steel sections interconnected with either a reinforced concrete slab or a steel deck with a concrete cover slab. The steel beams and the reinforced concrete slab are so interconnected that the beams and the slab act together to resist bending. Simple and continuous composite beams with shear connectors and concrete-encased beams, constructed with or without temporary shores, are included. Design philosophy for composite columns subjected to bending moments is also stated.

13.3.1 General

13.3.1.1 Deflections

Calculation of deflections shall take into account the effects of creep of concrete, shrinkage of concrete, and increased flexibility resulting from partial shear connection and from interfacial slip. These effects shall be established by test or analysis, where practicable. Consideration shall also be given to the effects of full or partial continuity in the steel beams and concrete slabs in reducing calculated deflections.

In lieu of tests or analysis, the effects of partial shear connection and interfacial slip, creep, and shrinkage may be assessed as follows:

- (a) For increased flexibility resulting from partial shear connection and interfacial slip, the deflections shall be calculated using an effective moment of inertia given by

$$I_e = I_s + 0.85p^{0.25}(I_t - I_s) \quad (6.13.18)$$

Where,

I_s = moment of inertia of a steel beam, or of a steel joist or truss adjusted to include the effect of shear deformations, which may be taken into account by decreasing the moment of inertia based on the cross-sectional areas of the top and bottom chords by 15% or by a more detailed analysis

p = fraction of full shear connection

= 1.00 for full shear connection

I_t = transformed moment of inertia of composite beam based on the modular ratio $n = E/E_c$.

- (b) For creep, elastic deflections caused by dead loads and long-term live loads, as calculated in Item (a), need to be increased by 15% and
- (c) For shrinkage of concrete, using a selected free shrinkage strain, strain compatibility between the steel and concrete, and an age-adjusted effective modulus of elasticity of concrete as it shrinks and creeps, the deflection of a simply supported composite beam, joist, or truss shall be calculated as follows:

$$\Delta_s = \frac{L^2}{8} \psi = \frac{L^2}{8} c \frac{\epsilon_f A_c \mathcal{V}}{n_s l_{es}} \quad (6.13.19)$$

Where,

L = span of the beam, joist, or truss

ψ = curvature along length of the beam, joist, or truss due to shrinkage of concrete

c = empirical coefficient used to match theory with test results (accounting for cracking of concrete in tension, the non-linear stress-strain relationship of concrete, and other factors) free shrinkage strain of concrete

A_c = effective area of concrete slab

y = distance from centroid of effective area of concrete slab to centroidal axis of the composite beam, joist, or truss

n_s = modular ratio, $\frac{E}{E_c}$

Age-adjusted effective modulus of elasticity of concrete E'_c is given by

$$E'_c = \frac{E_c}{1 + \chi\phi} \quad (6.13.20)$$

Where,

χ = aging coefficient of concrete

ϕ = creep coefficient of concrete

Effective moment of inertia of composite beam, truss, or joist based on the modular ratio n_s is given by

$$I_{es} = I_s + 0.85p^{0.25}(I_{ts} - I_s) \quad (6.13.21)$$

Where, I_{ts} = transformed moment of inertia based on the modular ratio n_s

13.3.1.2 Design effective width of concrete

The effective width of the concrete slab is the sum of the effective widths for each side of the beam centerline, each of which shall not exceed:

- one-eighth of the beam span, center-to-center of supports;
- one-half the distance to the centerline of the adjacent beam; or
- the distance to the edge of the slab.

13.3.1.3 Shear strength

The available shear strength of composite beams with shear connectors shall be determined based upon the properties of the steel section alone in accordance with Sec 10.7 Chapter 10 Part 6. The available shear strength of concrete-encased and filled composite members shall be determined based upon the properties of the steel section alone in accordance with Sec 10.7 Chapter 10 Part 6 or based upon the properties of the concrete and longitudinal steel reinforcement.

13.3.1.4 Strength during construction

When temporary shores are not used during construction, the steel section alone shall have adequate strength to support all loads applied prior to the concrete attaining 75 percent of its specified strength f'_c . The available flexural strength of the steel section shall be determined according to Sec 10.6 Chapter 10 Part 6.

13.3.2 Strength of Composite Beams with Shear Connectors

13.3.2.1 Positive flexural strength

The design positive flexural strength, $\phi_b M_n$ and the allowable positive flexural strength, M_n/Ω_b , shall be determined for the limit state of yielding as follows:

$$\phi_b = 0.90 \text{ (LRFD)} \quad \Omega_b = 1.67 \text{ (ASD)}$$

$$(a) \text{ For } \frac{h}{t_w} \leq 3.76 \sqrt{\frac{E}{F_y}}$$

M_n shall be determined from the plastic stress distribution on the composite section for the limit state of yielding (plastic moment).

$$(b) \text{ For } \frac{h}{t_w} > 3.76 \sqrt{\frac{E}{F_y}}$$

M_n shall be determined from the superposition of elastic stresses, considering the effects of shoring, for the limit state of yielding (yield moment).

13.3.2.2 Negative flexural strength

The design negative flexural strength, $\phi_b M_n$, and the allowable negative flexural strength, M_n/Ω_b , shall be determined for the steel section alone, in accordance with the requirements of Sec 10.6 Chapter 10 Part 6.

Alternatively, the available negative flexural strength shall be determined from the plastic stress distribution on the composite section, for the limit state of yielding (plastic moment), with

$$\phi_b = 0.90 \text{ (LRFD)} \quad \Omega_b = 1.67 \text{ (ASD)}$$

Provided that:

- (a) The steel beam is compact and is adequately braced according to Sec 10.6.
- (b) Shear connectors connect the slab to the steel beam in the negative moment region.
- (c) The slab reinforcement parallel to the steel beam, within the effective width of the slab, is properly developed.

13.3.2.3 Strength of composite beams with formed steel deck

13.3.2.3.1 General

The available flexural strength of composite construction consisting of concrete slabs on formed steel deck connected to steel beams shall be determined by the applicable portions of Sections 13.3.2.1 and 13.3.2.2, with the following requirements:

- (a) This section is applicable to decks with *nominal rib height* not greater than 75 mm. The average width of concrete rib or haunch, w_r , shall be not less than 50 mm, but shall not be taken in calculations as more than the minimum clear width near the top of the steel deck.
- (b) The concrete slab shall be connected to the steel beam with welded stud shear connectors 19 mm or less in diameter (AWS D1.1). Studs shall be welded either through the deck or directly to the steel cross section. Stud shear connectors, after installation, shall extend not less than 38 mm above the top of the steel deck and there shall be at least 13 mm of concrete cover above the top of the installed studs.
- (c) The slab thickness above the steel deck shall be not less than 50 mm.
- (d) Steel deck shall be anchored to all supporting members at a spacing not to exceed 460 mm. Such anchorage shall be provided by stud connectors, a combination of stud connectors and arc spot (puddle) welds, or other devices specified by the designer.

13.3.2.3.2 Deck ribs oriented perpendicular to steel beam

Concrete below the top of the steel deck shall be neglected in determining composite section properties and in calculating A_c for deck ribs oriented perpendicular to the steel beams.

13.3.2.3.3 Deck ribs oriented parallel to steel beam

Concrete below the top of the steel deck may be included in determining composite section properties and shall be included in calculating A_c .

Formed steel deck ribs over supporting beams may be split longitudinally and separated to form a concrete haunch.

When the nominal depth of steel deck is 38 mm or greater, the average width, w_r , of the supported haunch or rib shall be not less than 50 mm for the first stud in the transverse row plus four stud diameters for each additional stud.

13.3.2.4 Shear connectors

13.3.2.4.1 Load transfer for positive moment

The entire horizontal shear at the interface between the steel beam and the concrete slab shall be assumed to be transferred by shear connectors, except for concrete-encased beams as defined in Section 10.9.3.3. For composite action with concrete subject to flexural compression, the total horizontal shear force, V' , between the point of maximum positive moment and the point of zero moment shall be taken as the lowest value according to the limit states of concrete crushing, tensile yielding of the steel section, or strength of the shear connectors.

Concrete crushing:

$$V' = 0.85f'_cA_c \quad (6.13.22a)$$

Tensile yielding of the steel section:

$$V' = F_yA_s \quad (6.13.22b)$$

Strength of shear connectors:

$$V' = \sum Q_n \quad (6.13.22c)$$

Where,

A_c = area of concrete slab within effective width, mm²

A_s = area of steel cross section, mm²

$\sum Q_n$ = sum of nominal strengths of shear connectors between the point of maximum positive moment and the point of zero moment, N

13.3.2.4.2 Load transfer for negative moment

In continuous composite beams where longitudinal reinforcing steel in the negative moment regions is considered to act compositely with the steel beam, the total horizontal shear force between the point of maximum negative moment and the point of zero moment shall be taken as the lower value according to the limit states of yielding of the steel reinforcement in the slab, or strength of the shear connectors:

- (a) Tensile yielding of the slab reinforcement

$$V' = A_r F_{yr} \quad (6.13.23a)$$

Where,

A_r = area of adequately developed longitudinal reinforcing steel within the effective width of the concrete slab, mm²

F_{yr} = specified minimum yield stress of the reinforcing steel, MPa

- (b) Strength of shear connectors

$$V' = \sum Q_n \quad (6.13.23b)$$

13.3.2.4.3 Strength of stud shear connectors

The nominal strength of one stud shear connector embedded in solid concrete or in a composite slab is

$$Q_n = 0.5 A_{sc} \sqrt{f'_c E_c} \leq R_g R_p A_{sc} F_u \quad (6.13.24)$$

Where,

A_{sc} = cross-sectional area of stud *shear connector*, mm²

E_c = modulus of elasticity of concrete = $0.043 w_c^{1.5} \sqrt{f'_c}$, MPa

F_u = specified minimum tensile strength of a stud shear connector

$R_g = 1.0$

- (a) for one stud welded in a steel deck rib with the deck oriented perpendicular to the steel shape;
- (b) for any number of studs welded in a row directly to the steel shape;
- (c) for any number of studs welded in a row through steel deck with the deck oriented parallel to the steel shape and the ratio of the *average rib* width to rib depth ≥ 1.5

- $R_g = 0.85$ (a) for two studs welded in a steel deck rib with the deck oriented perpendicular to the steel shape;
- (b) for one stud welded through steel deck with the deck oriented parallel to the steel shape and the ratio of the average rib width to rib depth < 1.5
- $R_g = 0.7$ for three or more studs welded in a steel deck rib with the deck oriented perpendicular to the steel shape
- $R_p = 1.0$ for studs welded directly to the steel shape (in other words, not through steel deck or sheet) and having a haunch detail with not more than 50 percent of the top flange covered by deck or sheet steel closures
- $R_p = 0.75$ (a) for studs welded in a composite slab with the deck oriented perpendicular to the beam and $e_{mid-ht} \geq 50$ mm;
- (b) for studs welded through steel deck, or steel sheet used as girder filler material and embedded in a composite slab with the deck oriented parallel to the beam
- $R_p = 0.60$ for studs welded in a composite slab with deck oriented perpendicular to the beam and $e_{mid-ht} < 50$ mm

e_{mid-ht} = distance from the edge of stud shank to the steel deck web, measured at mid-height of the deck rib, and in the *load* bearing direction of the stud (in other words, in the direction of maximum moment for a simply supported beam), mm

w_c = weight of concrete per unit volume ($1500 \leq w_c \leq 2500$ kg/m³)

13.3.2.4.4 Strength of channel shear connectors

The nominal strength of one channel shear connector embedded in a solid concrete slab is

$$Q_n = 0.3(t_f + 0.5t_w)L_c\sqrt{f'_c E_c} \quad (6.13.25)$$

Where,

t_f = flange thickness of channel shear connector, mm

t_w = web thickness of channel shear connector, mm

L_c = length of channel shear connector, mm

The strength of the channel shear connector shall be developed by welding the channel to the beam flange for a force equal to Q_n , considering eccentricity on the connector.

13.3.2.4.5 Required number of shear connectors

The number of shear connectors required between the section of maximum bending moment, positive or negative, and the adjacent section of zero moment shall be equal to the horizontal shear force as determined in Sections 10.9.3.2d(1) and 10.9.3.2d(2) divided by the nominal strength of one shear connector as determined from Sec 10.9.3.2d(3) or Sec 10.9.3.2d(4).

13.3.2.4.6 Shear connector placement and spacing

Shear connectors required on each side of the point of maximum bending moment, positive or negative, shall be distributed uniformly between that point and the adjacent points of zero moment, unless otherwise specified. However, number of shear connectors placed between any concentrated load and the nearest point of zero moment shall be sufficient to develop the maximum moment required at the concentrated load point.

Shear connectors shall have at least 25 mm of lateral concrete cover, except for connectors installed in the ribs of formed steel decks. The diameter of studs shall not be greater than 2.5 times the thickness of the flange to which they are welded, unless located over the web. The minimum center-to-center spacing of stud connectors shall be six diameters along the longitudinal axis of the supporting composite beam and four diameters transverse to the longitudinal axis of the supporting composite beam, except that within the ribs of formed steel decks oriented perpendicular to the steel beam the minimum center-to-center spacing shall be four diameters in any direction. The maximum center-to-center spacing of shear connectors shall not exceed eight times the total slab thickness nor 900 mm.

13.3.3 Slab Reinforcement

13.3.3.1 General

Slabs shall be adequately reinforced to support all loads and to control both cracking transverse to the composite beam span and longitudinal cracking over the steel section. Reinforcement shall not be less than that required by the specified fire-resistance design of the assembly.

13.3.3.2 Parallel reinforcement

Reinforcement parallel to the span of the beam in regions of negative bending moment of the composite beam shall be anchored by embedment in concrete that is in compression. The reinforcement of slabs that are to be continuous over the end support of steel sections or joists fitted with flexible end connections shall be given special attention. Reinforcement at the ends of beams supporting ribbed slabs perpendicular to the beam shall be not less than two 16 mm bars or equivalent.

13.3.3.3 Transverse reinforcement-concrete slab on metal deck

Unless it is known from experience that longitudinal cracking caused by composite action directly over the steel section is unlikely, additional transverse reinforcement or other effective means shall be provided. Such additional reinforcement shall be placed in the lower part of the slab and anchored so as to develop the yield strength of the reinforcement. The area of such reinforcement shall be not less than 0.002 times the concrete area being reinforced and shall be uniformly distributed.

13.3.3.4 Transverse reinforcement- ribbed slabs

- (a) Where the ribs are parallel to the beam span, the area of transverse reinforcement shall be not less than 0.002 times the concrete cover slab area being reinforced and shall be uniformly distributed.
- (b) Where the ribs are perpendicular to the beam span, the area of transverse reinforcement shall be not less than 0.001 times the concrete cover slab area being reinforced and shall be uniformly distributed.

13.3.4 Flexural Strength of Concrete-Encased and Filled Members

The nominal flexural strength of concrete-encased and filled members shall be determined using one of the following methods:

- (a) The superposition of elastic stresses on the composite section, considering the effects of shoring, for the limit state of yielding (yield moment), where:

$$\phi_b = 0.90 \text{ (LRFD)} \quad \Omega_b = 1.67 \text{ (ASD)}$$

- (b) The plastic stress distribution on the steel section alone, for the limit state of yielding (plastic moment), where:

$$\phi_b = 0.90 \text{ (LRFD)} \quad \Omega_b = 1.67 \text{ (ASD)}$$

- (c) If shear connectors are provided and the concrete meets the requirements of Sec 10.9.1.2, the nominal flexural strength shall be computed based upon the plastic stress distribution on the composite section or from the strain compatibility method, where:

$$\phi_b = 0.85 \text{ (LRFD)} \quad \Omega_b = 1.76 \text{ (ASD)}$$

13.3.5 Combined Axial Force and Flexure

The interaction between axial forces and flexure in composite members shall account for stability as required by Chapter 10. The design compressive strength, $\phi_c P_n$, and allowable compressive strength, P_n/Ω_c and the design flexural strength, $\phi_b M_n$ and allowable flexural strength, M_n/Ω_b , are determined as follows:

$$\phi_c = 0.75 \text{ (LRFD)} \quad \Omega_c = 2.00 \text{ (ASD)}$$

$$\phi_b = 0.90 \text{ (LRFD)} \quad \Omega_b = 1.67 \text{ (ASD)}$$

13.3.5.1 The nominal strength of the cross section of a composite member subjected to combined axial compression and flexure shall be determined using either the plastic stress distribution method or the strain-compatibility method.

13.3.5.2 To account for the influence of length effects on the axial strength of the member, the nominal axial strength of the member shall be determined by Section 10.9 with P_o taken as the nominal axial strength of the cross section determined in Section 10.9.4(13) above.

13.3.6 Special Cases

When composite construction does not conform to the requirements of Sections 13.2 and 13.3, the strength of shear connectors and details of construction shall be established by testing.

13.4 Composite Connections

This Section is applicable to connections in buildings that utilize composite or dual steel and concrete systems. Composite connections shall be demonstrated to have Design Strength, ductility and toughness that is comparable to that exhibited by similar structural steel or reinforced concrete connections that meet the requirements in Chapters 5 and 10, Part 6 of this Code. Methods for calculating the connection strength shall meet the requirements in this Section.

13.4.1 General

Connections shall have adequate deformation capacity to resist the critical Required Strengths at the Design Story Drift. Additionally, connections that are required for the lateral stability of the building under seismic forces shall meet the requirements in Sec

13.5 based upon the specific system in which the connection is used. When the Required Strength is based upon nominal material strengths and nominal member dimensions, the determination of the required connection strength shall account for any effects that result from the increase in the actual Nominal Strength of the connected member.

13.4.2 Nominal Strength of Connections

The Nominal Strength of connections in composite Structural Systems shall be determined on the basis of rational models that satisfy both equilibrium of internal forces and the strength limitation of component materials and elements based upon potential limit states. Unless the connection strength is determined by analysis and testing, the models used for analysis of connections shall meet the following requirements:

13.4.2.1 When required, force shall be transferred between structural steel and reinforced concrete through direct bearing of headed shear studs or suitable alternative devices, by other mechanical means, by shear friction with the necessary clamping force provided by reinforcement normal to the plane of shear transfer, or by a combination of these means. Any potential bond strength between structural steel and reinforced concrete shall be ignored for the purpose of the connection force transfer mechanism.

13.4.2.2 The nominal bearing and shear-friction strengths shall meet the requirements in Chapters 6 and 10, Part 6 except that the strength reduction (resistance) factors shall be as given in Chapter 6 Part 6. Unless a higher strength is substantiated by cyclic testing, the nominal bearing and shear-friction strengths shall be reduced by 25 percent for the composite seismic systems.

13.4.2.3 The Design Strengths of structural steel components in composite connections, as determined in Sections 13.2 and 13.3 and the LRFD Specification, shall equal or exceed the Required Strengths. Structural steel elements that are encased in confined reinforced concrete are permitted to be considered to be braced against out of plane buckling. Face Bearing Plates consisting of stiffeners between the flanges of steel beams are required when beams are embedded in reinforced concrete columns or walls.

13.4.2.4 The nominal shear strength of reinforced-concrete-encased steel Panel Zones in beam-to-column connections shall be calculated as the sum of the Nominal Strengths of the structural steel and confined reinforced concrete shear elements as determined in Chapters 6 and 10, Part 6 of this Code. The strength reduction (resistance) factors for reinforced concrete shall be as given in Chapter 6 Part 6.

13.4.2.5 Reinforcement shall be provided to resist all tensile forces in reinforced concrete components of the connections. Additionally, the concrete shall be confined with transverse reinforcement. All reinforcement shall be fully developed in tension or compression, as appropriate, beyond the point at which it is no longer required to resist the forces. Development lengths shall be determined in accordance with Chapter 6 Part 6. Connections shall meet the following additional requirements:

- (a) When the slab transfers horizontal diaphragm forces, the slab reinforcement shall be designed and anchored to carry the in-plane tensile forces at all critical sections in the slab, including connections to collector beams, columns, braces and walls.
- (b) For connections between structural steel or Composite Beams and reinforced concrete or Reinforced-Concrete-Encased Composite Columns, transverse hoop reinforcement shall be provided in the connection region to meet the requirements in Chapter 6 Part 6 except for the following modifications:
 - (i) Structural steel sections framing into the connections are considered to provide confinement over a width equal to that of face bearing stiffener plates welded to the beams between the flanges.
 - (ii) Lap splices are permitted for perimeter ties when confinement of the splice is provided by Face Bearing Plates or other means that prevents spalling of the concrete cover.
- (c) The longitudinal bar sizes and layout in reinforced concrete and Composite Columns shall be detailed to minimize slippage of the bars through the beam-to-column connection due to high force transfer associated with the change in column moments over the height of the connection.

13.5 Seismic Provisions for Composite Structural Systems

These Provisions are intended for the design and construction of composite structural steel and reinforced concrete members and connections in the Seismic Load Resisting Systems in buildings for which the design forces resulting from earthquake motions have been determined on the basis of various levels of energy dissipation in the inelastic range of response.

13.5.1 Scope

Provisions shall be applied in conjunction with the AISC Load and Resistance Factor Design (LRFD) Specification for Structural Steel Buildings, hereinafter referred to as the LRFD Specification. All members and connections in the Seismic Load Resisting System shall have a Design Strength as required in the LRFD Specification and shall meet the requirements in these Provisions. The applicable requirements in Chapter 10 Part 6 shall be used for the design of structural steel components in composite systems. Reinforced-concrete members subjected to seismic forces shall meet the requirements in Chapters 6 and 10, Part 6 except as modified in these provisions. When the design is based upon elastic analysis, the stiffness properties of the component members of composite systems shall reflect their condition at the onset of significant yielding of the building.

13.5.2 Seismic Design Categories

The Required Strength and other seismic provisions for Seismic Design Categories, Seismic Use Groups or Seismic Zones and the limitations on height and irregularity shall be as stipulated in Chapter 2 Part 6.

13.5.3 Loads, Load Combinations, and Nominal Strengths

The loads and load combinations shall be as stipulated by the Applicable Building Code. Where Amplified Seismic Loads are required by these provisions, the horizontal earthquake load E (as defined in Chapter 2 Part 6) shall be multiplied by the over strength factor Ω_o prescribed by Chapter 2 Part 6.

13.5.4 Materials

13.5.4.1 Structural Steel

Structural steel used in composite Seismic Load Resisting Systems shall meet the requirements in Sec 10.20 Chapter 10 Part 6 in addition Sec 13.1 of this Chapter. The structural steels that are explicitly permitted for use in seismic design have been selected based upon their inelastic properties and weld ability. In general, they meet the following characteristics: (1) a ratio of yield stress to tensile stress not greater than 0.85; (2) a pronounced stress-strain plateau at the yield stress; (3) a large inelastic strain capability (for example, tensile elongation of 20 percent or greater in a 2-in. (50 mm) gage length); and (4) good weldability. Other steels should not be used without evidence that the above criteria are met.

13.5.4.2 Concrete and steel reinforcement

Concrete and steel reinforcement used in composite Seismic Load Resisting Systems shall meet the requirements in Chapter 5 Part 6, and the following requirements:

- (a) The specified minimum compressive strength of concrete in composite members shall equal or exceed 2.5 ksi (17 MPa).
- (b) For the purposes of determining the Nominal Strength of composite members, f'_c shall not be taken as greater than 10 ksi (69 MPa) for normal-weight concrete nor 4 ksi (28 MPa) for lightweight concrete.

Concrete and steel reinforcement used in the composite Seismic Load Resisting Systems described shall also meet the requirements in Chapter 8 Part 6.

13.5.5 Composite Members

13.5.5.1 Composite floor and roof slabs

The design of composite floor and roof slabs shall meet the requirements of ASCE 3-91. Composite slab diaphragms shall meet the requirements in this Section.

Details shall be designed to transfer forces between the diaphragm and Boundary Members, Collector Elements, and elements of the horizontal framing system.

The nominal shear strength of composite diaphragms and concrete-filled steel deck diaphragms shall be taken as the nominal shear strength of the reinforced concrete above the top of the steel deck ribs in accordance with Chapter 6 Part 6. Alternatively, the composite diaphragm design shear strength shall be determined by in-plane shear tests of concrete-filled diaphragms.

13.5.5.2 Composite beams

Composite Beams shall meet the requirements in Sec 13.3. Composite Beams that are part of C-SMF shall also meet the following requirements:

- (a) The distance from the maximum concrete compression fiber to the plastic neutral axis shall not exceed:

$$\frac{Y_{con} + d_b}{1 + \left(\frac{1700F_y}{E_s} \right)} \quad (6.13.26)$$

Where,

Y_{con} = distance from the top of the steel beam to the top of concrete, mm

d_b = depth of the steel beam, mm

F_y = specified minimum yield strength of the steel beam, MPa

E_s = modulus of elasticity of the steel beam, MPa

- (b) Beam flanges shall meet the requirements in Part 6 Sec 10.20.9.4.2, except when fully reinforced-concrete-encased compression elements have a reinforced concrete cover of at least 2 in. (50 mm) and confinement is provided by hoop reinforcement in regions where plastic hinges are expected to occur under seismic deformations. Hoop reinforcement shall meet the requirements in Chapter 8 Part 6.

13.5.5.3 Reinforced concrete encased composite columns

This Section is applicable to columns that: (i) consist of reinforced-concrete encased structural steel sections with a structural steel area that comprises at least 4 percent of the total composite-column cross-section; and (ii) meet the additional limitations in Sec 13.2.2.1. Such columns shall meet the requirements in Sec 13.2.2, except as modified in this Section. Additional requirements, as specified for intermediate and special seismic systems in Sections 13.5.5.3.2 and 13.5.5.3.3, shall apply as required.

Columns that consist of reinforced-concrete-encased structural steel sections with a structural steel area that comprises less than 4 percent of the total composite column cross-section shall meet the requirements for reinforced concrete columns in Chapter 6 Part 6 except as modified for:

- (a) The steel shape shear connectors in Sec 13.5.4.3.1 (2).
- (b) The contribution of the reinforced-concrete-encased structural steel section to the strength of the column as provided in Chapter 6 Part 6.
- (c) The seismic requirements for reinforced concrete columns as specified in the description of the composite seismic systems in Sections 13.5.5.3.1 to 13.5.5.3.3.

13.5.5.3.1 Ordinary seismic system requirements

The following requirements for Reinforced-Concrete-Encased Composite Columns are applicable to all composite systems:

- (a) The nominal shear strength of the column shall be determined as the nominal shear strength of the structural shape plus the nominal shear strength that is provided by the tie reinforcement in the reinforced-concrete encasement. The nominal shear strength of the structural steel section shall be determined in accordance with Sec 10.20 Chapter 10 Part 6. The nominal shear strength of the tie reinforcement shall be determined in accordance with Chapter 6 Part 6. In Chapter 6 Part 6, the dimension b_w shall equal the width of the concrete cross-section minus the width of the structural shape measured perpendicular to the direction of shear. The nominal shear strength shall be multiplied by ϕ_v equal to 0.75 to determine the design shear strength.
- (b) Composite Columns that are designed to share the applied loads between the structural steel section and reinforced concrete shall have shear connectors that meet the following requirements:
 - (i) If an external member is framed directly to the structural steel section to transfer a vertical reaction V_u , shear connectors shall be provided to transfer the force $V_u(1 - A_s F_y / P_n)$ between the structural steel section and the reinforced concrete, where A_s is the area of the structural steel section, F_y is the specified minimum yield strength of the structural steel section, and P_n is the nominal compressive strength of the Composite Column.
 - (ii) If an external member is framed directly to the reinforced concrete to transfer a vertical reaction V_u , shear connectors shall be provided to transfer the force $V_u A_s F_y / P_n$ between the structural steel section and the reinforced concrete, where A_s , F_y and P_n are as defined above.
 - (iii) The maximum spacing of shear connectors shall be 16 in. (406 mm) with attachment along the outside flange faces of the embedded shape.
- (c) The maximum spacing of transverse ties shall be the least of the following:
 - (i) one-half the least dimension of the section
 - (ii) 16 longitudinal bar diameters
 - (iii) 48 tie diameters

Transverse ties shall be located vertically within one-half the tie spacing above the top of the footing or lowest beam or slab in any story and shall be spaced as provided herein within one-half the tie spacing below the lowest beam or slab framing into the column.

Transverse bars shall have a diameter that is not less than one-fiftieth of greatest side dimension of the composite member, except that ties shall not be smaller than No. 3 bars and need not be larger than No. 5 bars. Alternatively, welded wire fabric of equivalent area is permitted as transverse reinforcement except when prohibited for intermediate and special systems.

- (d) All Load-Carrying Reinforcement shall meet the detailing and splice requirements in Chapter 8 Part 6. Load-Carrying Reinforcement shall be provided at every corner of a rectangular cross-section. The maximum spacing of other load carrying or restraining longitudinal reinforcement shall be one-half of the least side dimension of the composite member.
- (e) Splices and end bearing details for reinforced-concrete-encased structural steel sections shall meet the requirements in Chapter 8 Part 6. If adverse behavioral effects due to the abrupt change in member stiffness and nominal tensile strength occur when reinforced-concrete encasement of a structural steel section is terminated, either at a transition to a pure reinforced concrete column or at the Column Base, they shall be considered in the design.

13.5.5.3.2 Intermediate seismic system requirements

Reinforced-Concrete-Encased Composite Columns in intermediate seismic systems shall meet the following requirements in addition to those in Sec 13.5.5.3.1:

- (a) The maximum spacing of transverse bars at the top and bottom shall be the least of the following:
 - (i) one-half the least dimension of the section
 - (ii) 8 longitudinal bar diameters
 - (iii) 24 tie bar diameters
 - (iv) 12 in. (305 mm)

These spacing shall be maintained over a vertical distance equal to the greatest of the following lengths, measured from each joint face and on both sides of any section where flexural yielding is expected to occur:

- (i) one-sixth the vertical clear height of the column
- (ii) the maximum cross-sectional dimension
- (iii) 18 in. (457 mm)

- (b) Tie spacing over the remaining column length shall not exceed twice the spacing defined above.
- (c) Welded wire fabric is not permitted as transverse reinforcement in intermediate seismic systems.

13.5.5.3.3 Special seismic system requirements

Reinforced-concrete-encased columns for special seismic systems shall meet the following requirements in addition to those in Sections 13.5.4.3.2 and 13.5.4.4.3:

- (a) The required axial strength for Reinforced-Concrete-Encased Composite Columns and splice details shall meet the requirements in Sec 13.2.
- (b) Longitudinal Load-Carrying Reinforcement shall meet the requirements in Chapter 6 Part 6.
- (c) Transverse reinforcement shall be hoop reinforcement as defined in Chapter 6 Part 6 and shall meet the following requirements:

The minimum area of tie reinforcement A_{sh} shall meet the following requirement:

$$A_{sh} = 0.09h_{cc}s \left(1 - \frac{F_y A_s}{P_n} \right) \left(\frac{f'_c}{F_{yh}} \right) \quad (6.13.27)$$

Where,

h_{cc} = cross-sectional dimension of the confined core measured center-to-center of the tie reinforcement, mm

s = spacing of transverse reinforcement measured along the longitudinal axis of the structural member, mm

F_y = specified minimum yield strength of the structural steel core, MPa

A_s = cross-sectional area of the structural core, mm²

P_n = nominal axial compressive strength of the Composite Column calculated in accordance with the LRFD Specification, N

f'_c = specified compressive strength of concrete, MPa

F_{yh} = specified minimum yield strength of the ties, MPa

Equation 6.13.27 need not be satisfied if the Nominal Strength of the reinforced concrete encased structural steel section alone is greater than $1.0D + 0.5L$.

The maximum spacing of transverse reinforcement along the length of the column shall be the lesser of 6 longitudinal load-carrying bar diameters and 152 mm (6 in.).

When specified in Sec 13.5.5.3.3, the maximum spacing of transverse reinforcement shall be the lesser of one-fourth the least member dimension and 102 mm (4 in.). For this reinforcement, cross ties, legs of overlapping hoops, and other confining reinforcement shall be spaced not more than 355 mm (14 in.) on center in the transverse direction.

- (d) Reinforced-Concrete-Encased Composite Columns in Braced Frames with axial compression forces that are larger than 0.2 times P_0 shall have transverse reinforcement as specified in Sec 13.5.5.3.3, over the total element length. This requirement need not be satisfied if the Nominal Strength of the reinforced-concrete-encased steel section alone is greater than $1.0D + 0.5L$.
- (e) Composite Columns supporting reactions from discontinued stiff members, such as walls or Braced Frames, shall have transverse reinforcement as specified in Sec 13.5.5.3.3 over the full length beneath the level at which the discontinuity occurs if the axial compression force exceeds 0.1 times P_0 . Transverse reinforcement shall extend into the discontinued member for at least the length required to develop full yielding in the reinforced-concrete-encased structural steel section and longitudinal reinforcement. This requirement need not be satisfied if the Nominal Strength of the reinforced-concrete-encased structural steel section alone is greater than $1.0D + 0.5L$.
- (f) Reinforced-Concrete-Encased Composite Columns that are used in C-SMF shall meet the following requirements:
 - (i) Transverse reinforcement shall meet the requirements in 13.5.5.3.3 at the top and bottom of the column over the region specified in Sec 6.4b.
 - (ii) The strong-column/weak-beam design requirements shall be satisfied. Column Bases shall be detailed to sustain inelastic flexural hinging.
 - (iii) The minimum required shear strength of column shall meet the requirements in Chapter 6 Part 6.

- (g) When the column terminates on a footing or mat foundation, the transverse reinforcement as specified in this section shall extend into the footing or mat at least 305 mm (12 in.). When the column terminates on a wall, the transverse reinforcement shall extend into the wall for at least the length required to develop full yielding in the reinforced-concrete-encased structural steel section and longitudinal reinforcement.
- (h) Welded wire fabric is not permitted as transverse reinforcement for special seismic systems.

13.5.5.4 Concrete filled composite columns

This Section is applicable to columns that: (i) consist of concrete-filled steel rectangular or circular hollow structural sections (HSS) with a structural steel area that comprises at least 4 percent of the total composite-column cross-section; and (ii) meet the additional limitations in Sec 13.2. Such columns shall be designed to meet the requirements in Sec 13.2, except as modified in this Section.

The design shear strength of the Composite Column shall be the design shear strength of the structural steel section alone.

In the special seismic systems described in, members and column splices for Concrete-Filled Composite Columns shall also meet the requirements in Sec 10.20 Chapter 10 Part 6.

Concrete-Filled Composite Columns used in C-SMF shall meet the following additional requirements:

- (a) The minimum required shear strength of the column shall meet the requirements in Chapter 5 Part 6.
- (b) The strong-column/weak-beam design requirements shall be met. Column Bases shall be designed to sustain inelastic flexural hinging.
- (c) The minimum wall thickness of concrete-filled rectangular HSS shall equal $b\sqrt{F_y/(2E_s)}$ for the flat width b of each face, where b is as defined in Table 6.10.1 Chapter 10 Part 6.

13.5.6 Composite Steel Plate Shear Walls (C-SPW)

13.5.6.1 Scope

This Section is applicable to structural walls consisting of steel plates with reinforced concrete encasement on one or both sides of the plate and structural steel or composite Boundary Members. C-SPW shall meet the requirements of this section.

13.5.6.2 Wall elements

13.5.6.2.1 Nominal shear strength

The nominal shear strength of C-SPW with a stiffened plate conforming to Section 13.5.4.2.2 shall be determined as:

$$V_{ns} = 0.6A_{sp}F_y \quad (6.13.28)$$

Where,

V_{ns} = nominal shear strength of the steel plate, N

A_{sp} = horizontal area of stiffened steel plate, mm²

F_y = specified minimum yield strength of the plate, MPa

The nominal shear strength of C-SPW with a plate that does not meet the stiffening requirements in Sec 13.5.4.2.2 shall be based upon the strength of the plate, excluding the strength of the reinforced concrete, and meet the requirements in the Chapter 10 Part 6, including the effects of buckling of the plate.

13.5.6.2.2 Detailing requirements

The steel plate shall be adequately stiffened by encasement or attachment to the reinforced concrete if it can be demonstrated with an elastic plate buckling analysis that the composite wall can resist a nominal shear force equal to V_{ns} . The concrete thickness shall be a minimum of 100 mm (4 in.) on each side when concrete is provided on both sides of the steel plate and 200 mm (8 in.) when concrete is provided on one side of the steel plate. Headed shear stud connectors or other mechanical connectors shall be provided to prevent local buckling and separation of the plate and reinforced concrete. Horizontal and vertical reinforcement shall be provided in the concrete encasement to meet the detailing requirements in Chapter 8 Part 6. The reinforcement ratio in both directions shall not be less than 0.0025; maximum spacing between bars shall not exceed 450 mm (18 in.).

The steel plate shall be continuously connected on all edges to structural steel framing and Boundary Members with welds and/or slip-critical high-strength bolts to develop the nominal shear strength of the plate. The Design Strength of welded and bolted connectors shall meet the additional requirements in Chapter 10 Part 6.

13.6 Referenced Specifications, Codes and Standards

The documents referenced in these provisions shall include those listed in Sec 10.1.2.3 Chapter 10 Part 6 with the following additions and modifications:

American Society of Civil Engineers

ASCE 3-91 Standard for the Structural Design of Composite Slabs

American Welding Society

AWS D1.1-04 Structural Welding Code- Steel

AWS D1.4-98 Structural Welding Code-Reinforcing Steel

Canadian Standards Association

CSA S16-01 Design of Steel Structures

PART VI

Appendix A

Equivalence of Nonhomogenous Equations in SI-Metric,
MKS-Metric, and U.S. Customary Units

Reference	SI-metric stress in MPa	MKS-metric stress in kgf/cm ²	U.S. Customary unit stress in pounds per square inch (psi)
General	1 MPa	10 kgf/cm ²	142.2 psi
	$f'_c = 21$ MPa	$f'_c = 210$ kgf/cm ²	$f'_c = 3000$ psi
	$f'_c = 28$ MPa	$f'_c = 280$ kgf/cm ²	$f'_c = 4000$ psi
	$f'_c = 35$ MPa	$f'_c = 350$ kgf/cm ²	$f'_c = 5000$ psi
	$f'_c = 40$ MPa	$f'_c = 420$ kgf/cm ²	$f'_c = 6000$ psi
	$f_y = 280$ MPa	$f_y = 2800$ kgf/cm ²	$f_y = 40,000$ psi
	$f_y = 420$ MPa	$f_y = 4200$ kgf/cm ²	$f_y = 60,000$ psi
	$f_{pu} = 1725$ MPa	$f_{pu} = 17,600$ kgf/cm ²	$f_{pu} = 250,000$ psi
	$f_{pu} = 1860$ MP	$f_{pu} = 19,000$ kgf/cm ²	$f_{pu} = 270,000$ psi
	$\sqrt{f'_c}$ in MPa	$3.18 \sqrt{f'_c}$ in kgf/cm ²	$12 \sqrt{f'_c}$ in psi
	$0.313 \sqrt{f'_c}$ in MPa	$\sqrt{f'_c}$ in kgf/cm ²	$3.77 \sqrt{f'_c}$ in psi
	$0.083 \sqrt{f'_c}$ in MPa	$0.27 \sqrt{f'_c}$ in kgf/cm ²	$\sqrt{f'_c}$ in psi
	$0.17 \sqrt{f'_c}$ in MPa	$0.53 \sqrt{f'_c}$ in kgf/cm ²	$2\sqrt{f'_c}$ in psi
	$f'_{cr} = f'_c + 2.33S_s - 35$	$f'_{cr} = f'_c + 2.33S_s - 35$	$f'_{cr} = f'_c + 2.33S_s - 35$
	$f'_{cr} = f'_c + 7.0$	$f'_{cr} = f'_c + 70$	$f'_{cr} = f'_c + 1000$
	$f'_{cr} = f'_c + 8.3$	$f'_{cr} = f'_c + 84$	$f'_{cr} = f'_c + 1200$
	$f'_{cr} = 1.10f'_c + 5.0$	$f'_{cr} = 1.10f'_c + 50$	$f'_{cr} = 1.10f'_c + 700$

Reference	SI-metric stress in MPa	MKS-metric stress in kgf/cm ²	U.S. Customary unit stress in pounds per square inch (psi)
Eq. 6.6.3	$f_r = 0.62\lambda\sqrt{f'_c}$	$f_r = 2\lambda\sqrt{f'_c}$	$f_r = 7.5\lambda\sqrt{f'_c}$
Eq. 6.6.5	$h = \frac{\ell_n \left(0.8 + \frac{f_y}{1400}\right)}{36 + 5\beta(\alpha_{fm} - 0.2)} \geq 125mm$	$h = \frac{\ell_n \left(0.8 + \frac{f_y}{1400}\right)}{36 + 5\beta(\alpha_{fm} - 0.2)} \geq 125mm$	$h = \frac{\ell_n \left(0.8 + \frac{f_y}{200,000}\right)}{36 + 5\beta(\alpha_{fm} - 0.2)} \geq 5m$
Eq. 6.6.6	$h = \frac{\ell_n \left(0.8 + \frac{f_y}{1400}\right)}{36 + 9\beta} \geq 90mm$	$h = \frac{\ell_n \left(0.8 + \frac{f_y}{14,000}\right)}{36 + 9\beta} \geq 9cm$	$h = \frac{\ell_n \left(0.8 + \frac{f_y}{200,000}\right)}{36 + 9\beta} \geq 3.5in$
Eq. 6.6.10	$A \frac{0.25\sqrt{f'_c}}{f_y} \frac{1.4}{w f_y w_{s,min}}$	$A \frac{0.8\sqrt{f'_c}}{f_y} \frac{14}{w f_y w_{s,min}}$	$A \frac{3\sqrt{f'_c}}{f_y} \frac{200}{w f_y w_{s,min}}$
Eq. 6.6.11	$s = 380 \left(\frac{280}{f_s}\right) - 2.5c_c \leq 300 \left(\frac{280}{f_s}\right)$	$s = 38 \left(\frac{2800}{f_s}\right) - 2.5c_c \leq 30 \left(\frac{2800}{f_s}\right)$	$s = 15 \left(\frac{40,000}{f_s}\right) - 2.5c_c \leq 12 \left(\frac{40,000}{f_s}\right)$
Eq. 6.6.24	$M_{2,min} = P_u (15 + 0.03h)$	$M_{2,min} = P_u (1.5 + 0.03h)$	$M_{2,min} = P_u (0.6 + 0.03h)$
Eq. 6.6.49	$V_c = 0.17\lambda\sqrt{f'_c} b_w d$	$V_c = 0.53\lambda\sqrt{f'_c} b_w d$	$V_c = 2\lambda\sqrt{f'_c} b_w d$
Eq. 6.6.50	$V_c = 0.17 \left(1 + \frac{N_u}{14A_g}\right) \lambda\sqrt{f'_c} b_w d$	$V_c = 0.53 \left(1 + \frac{N_u}{140A_g}\right) \lambda\sqrt{f'_c} b_w d$	$V_c = 2 \left(1 + \frac{N_u}{2000A_g}\right) \lambda\sqrt{f'_c} b_w d$
Eq. 6.6.51	$V_c = \left(0.16\lambda\sqrt{f'_c} + 17\rho_w \frac{V_c d}{M_u}\right) b_w d \leq 0.29\lambda\sqrt{f'_c} b_w d$	$V_c = \left(0.5\lambda\sqrt{f'_c} + 176\rho_w \frac{V_c d}{M_u}\right) b_w d \leq 0.93\lambda\sqrt{f'_c} b_w d$	$V_c = \left(1.9\lambda\sqrt{f'_c} + 25006\rho_w \frac{V_c d}{M_u}\right) b_w d \leq 3.5\lambda\sqrt{f'_c} b_w d$
Eq. 6.6.53	$V_c = 0.29\lambda\sqrt{f'_c} b_w d \sqrt{1 + \frac{0.29N_u}{A_g}}$	$V_c = 0.93\lambda\sqrt{f'_c} b_w d \sqrt{1 + \frac{N_u}{35A_g}}$	$V_c = 3.5\lambda\sqrt{f'_c} b_w d \sqrt{1 + \frac{N_u}{500A_g}}$
Eq. 6.6.54	$V_c = 0.17 \left(1 + \frac{0.29N_u}{A_g}\right) \lambda\sqrt{f'_c} b_w d \geq 0$	$V_c = 0.53 \left(1 + \frac{N_u}{35A_g}\right) \lambda\sqrt{f'_c} b_w d \geq 0$	$V_c = 2 \left(1 + \frac{N_u}{500A_g}\right) \lambda\sqrt{f'_c} b_w d \geq 0$

Reference	SI-metric stress in MPa	MKS-metric stress in kgf/cm ²	U.S. Customary unit stress in pounds per square inch (psi)
Eq. 6.6.55	$A\sqrt{f'_c}\frac{b_w s}{f_{yt\ v,min}}$ $\geq 0.35\frac{b_w s}{f_{yt}}$	$A\sqrt{f'_c}\frac{b_w s}{f_{yt\ v,min}}$ $\geq 3.5\frac{b_w s}{f_{yt}}$	$A\sqrt{f'_c}\frac{b_w s}{f_{yt\ v,min}}$ $\geq 50\frac{b_w s}{f_{yt}}$
Eq. 6.6.58	$V_s = A_v f_y \sin \alpha \leq 0.25\sqrt{f'_c} b_w d$	$V_s = A_v f_y \sin \alpha \leq 0.8\sqrt{f'_c} b_w d$	$V_s = A_v f_y \sin \alpha \leq 3\sqrt{f'_c} b_w d$
Eq. 6.6.59	$\sqrt{\left(\frac{V_u}{b_w d}\right)^2 + \left(\frac{T_u p_h}{1.7A_{oh}^2}\right)^2}$ $\leq \varphi \left(\frac{V_c}{b_w d} + 0.66\sqrt{f'_c}\right)$	$\sqrt{\left(\frac{V_u}{b_w d}\right)^2 + \left(\frac{T_u p_h}{1.7A_{oh}^2}\right)^2}$ $\leq \varphi \left(\frac{V_c}{b_w d} + 2\sqrt{f'_c}\right)$	$\sqrt{\left(\frac{V_u}{b_w d}\right)^2 + \left(\frac{T_u p_h}{1.7A_{oh}^2}\right)^2}$ $\leq \varphi \left(\frac{V_c}{b_w d} + 8\sqrt{f'_c}\right)$
Eq. 6.6.60	$\left(\frac{V_u}{b_w d}\right) + \left(\frac{T_u p_h}{1.7A_{oh}^2}\right)$ $\leq \varphi \left(\frac{V_c}{b_w d} + 0.66\sqrt{f'_c}\right)$	$\left(\frac{V_u}{b_w d}\right) + \left(\frac{T_u p_h}{1.7A_{oh}^2}\right)$ $\leq \varphi \left(\frac{V_c}{b_w d} + 2\sqrt{f'_c}\right)$	$\left(\frac{V_u}{b_w d}\right) + \left(\frac{T_u p_h}{1.7A_{oh}^2}\right)$ $\leq \varphi \left(\frac{V_c}{b_w d} + 8\sqrt{f'_c}\right)$
Eq. 6.6.64	$(A_v + 2A_t) = 0.062\sqrt{f'_c}\frac{b_w s}{f_{yt}}$ $\geq \frac{0.35b_w s}{f_{yt}}$	$(A_v + 2A_t) = 0.2\sqrt{f'_c}\frac{b_w s}{f_{yt}}$ $\geq \frac{3.5b_w s}{f_{yt}}$	$(A_v + 2A_t) = 0.75\sqrt{f'_c}\frac{b_w s}{f_{yt}}$ $\geq \frac{50b_w s}{f_{yt}}$
Eq. 6.6.65	$A\frac{0.42\sqrt{f'_c}A_{cp}\left(\frac{A_t}{s}\right)_h f_{yt}}{f_y f_{yt\ tmin}}$ $\frac{A_t}{s} \geq \frac{0.175b_w}{f_{yt}}$	$A\frac{1.33\sqrt{f'_c}A_{cp}\left(\frac{A_t}{s}\right)_h f_{yt}}{f_y f_{yt\ tmin}}$ $\frac{A_t}{s} \geq \frac{1.75b_w}{f_{yt}}$	$A\frac{5\sqrt{f'_c}A_{cp}\left(\frac{A_t}{s}\right)_h f_{yt}}{f_y f_{yt\ tmin}}$ $\frac{A_t}{s} \geq \frac{25b_w}{f_{yt}}$
Eq. 6.6.68	$V_c = 0.27\lambda\sqrt{f'_c}h + \frac{N_u d}{4\ell_w}$	$V_c = 0.88\lambda\sqrt{f'_c}hd + \frac{N_u d}{4\ell_w}$	$V_c = 3.3\lambda\sqrt{f'_c}hd + \frac{N_u d}{4\ell_w}$

Reference	SI-metric stress in MPa	MKS-metric stress in kgf/cm ²	U.S. Customary unit stress in pounds per square inch (psi)
Eq. 6.6.69	$V_c = \left[0.05\lambda\sqrt{f'_c} + \frac{l_w \left(0.1\lambda\sqrt{f'_c} + \frac{0.2N_u}{l_w h} \right)}{\frac{M_u}{V_u} - \frac{l_w}{2}} \right] h d$	$V_c = \left[0.16\lambda\sqrt{f'_c} + \frac{l_w \left(0.33\lambda\sqrt{f'_c} + \frac{0.2N_u}{l_w h} \right)}{\frac{M_u}{V_u} - \frac{l_w}{2}} \right] h d$	$V_c = \left[0.6\lambda\sqrt{f'_c} + \frac{l_w \left(1.25\lambda\sqrt{f'_c} + \frac{0.2N_u}{l_w h} \right)}{\frac{M_u}{V_u} - \frac{l_w}{2}} \right] h d$
Eq. 6.6.72	$V_c = 0.17 \left(1 + \frac{2}{\beta} \right) \lambda\sqrt{f'_c} b_o d$	$V_c = 0.53 \left(1 + \frac{2}{\beta} \right) \lambda\sqrt{f'_c} b_o d$	$V_c = \left(2 + \frac{4}{\beta} \right) \lambda\sqrt{f'_c} b_o d$
Eq. 6.6.73	$V_c = 0.083 \left(\frac{\alpha_s d}{b_o} + 2 \right) \lambda\sqrt{f'_c} b_o d$	$V_c = 0.27 \left(\frac{\alpha_s d}{b_o} + 2 \right) \lambda\sqrt{f'_c} b_o d$	$V_c = \left(\frac{\alpha_s d}{b_o} + 2 \right) \lambda\sqrt{f'_c} b_o d$
Eq. 6.6.74	$V_c = 0.33\lambda\sqrt{f'_c} b_o d$	$V_c = \lambda\sqrt{f'_c} b_o d$	$V_c = 4\lambda\sqrt{f'_c} b_o d$
Eq. 6.8.1	$e_d = \frac{f_y}{1.1\lambda\sqrt{f'_c}} \frac{\psi_t \psi_e \psi_s}{\left(\frac{c_b + K_{tr}}{d_b} \right)} d_b$	$e_d = \frac{f_y}{3.5\lambda\sqrt{f'_c}} \frac{\psi_t \psi_e \psi_s}{\left(\frac{c_b + K_{tr}}{d_b} \right)} d_b$	$e_d = \frac{3f_y}{40\lambda\sqrt{f'_c}} \frac{\psi_t \psi_e \psi_s}{\left(\frac{c_b + K_{tr}}{d_b} \right)} d_b$
Eq. 6.8.4	$e_d = 3.3 \left(\frac{A_b}{s} \right) \left(\frac{f_y}{\lambda\sqrt{f'_c}} \right)$	$e_d = \left(\frac{A_b}{s} \right) \left(\frac{f_y}{\lambda\sqrt{f'_c}} \right)$	$e_d = 0.27 \left(\frac{A_b}{s} \right) \left(\frac{f_y}{\lambda\sqrt{f'_c}} \right)$
Eq. 6.8.9	$e_{dh} = \frac{f_y d_b}{5.4\sqrt{f'_c}}$	$e_{dh} = \frac{f_y d_b}{17.2\sqrt{f'_c}}$	$e_{dh} = \frac{f_y d_b}{65\sqrt{f'_c}}$
Eq. 6.8.10	$V_n = A_{cv} (0.17\lambda\sqrt{f'_c} + \rho_n f_y)$	$V_n = A_{cv} (0.53\lambda\sqrt{f'_c} + \rho_n f_y)$	$V_n = A_{cv} (2\lambda\sqrt{f'_c} + \rho_n f_y)$
Eq. 6.8.11	$V_n = 2A_{vd} f_y \sin \alpha$ $\leq 0.83\sqrt{f'_c} A_{cw}$	$V_n = 2A_{vd} f_y \sin \alpha$ $\leq 2.65\sqrt{f'_c} A_{cw}$	$V_n = 2A_{vd} f_y \sin \alpha$ $\leq 10\sqrt{f'_c} A_{cw}$

Reference	SI-metric stress in MPa	MKS-metric stress in kgf/cm ²	U.S. Customary unit stress in pounds per square inch (psi)
Eq. 6.8.14	$V_n = A_{cv}(\alpha_c \lambda \sqrt{f'_c} + \rho_n f_y)$ $\alpha_c = 0.25$ for $\frac{h_w}{\ell_w} \leq 1.5$ $\alpha_c = 0.17$ for $\frac{h_w}{\ell_w} \geq 2.0$	$V_n = A_{cv}(\alpha_c \lambda \sqrt{f'_c} + \rho_n f_y)$ $\alpha_c = 0.80$ for $\frac{h_w}{\ell_w} \leq 1.5$ $\alpha_c = 0.53$ for $\frac{h_w}{\ell_w} \geq 2.0$	$V_n = A_{cv}(\alpha_c \lambda \sqrt{f'_c} + \rho_n f_y)$ $\alpha_c = 3.0$ for $\frac{h_w}{\ell_w} \leq 1.5$ $\alpha_c = 2.0$ for $\frac{h_w}{\ell_w} \geq 2.0$
Eq. D.7	$N_b = k_c \lambda \sqrt{f'_c} h_{ef}^{1.5}$ $k_c = 10$ or 7	$N_b = k_c \lambda \sqrt{f'_c} h_{ef}^{1.5}$ $k_c = 10$ or 7	$N_b = k_c \lambda \sqrt{f'_c} h_{ef}^{1.5}$ $k_c = 24$ or 17
Eq. D.8	$N_b = 3.9 \lambda \sqrt{f'_c} h_{ef}^{5/3}$	$N_b = 5.8 \lambda \sqrt{f'_c} h_{ef}^{5/3}$	$N_b = 16 \lambda \sqrt{f'_c} h_{ef}^{5/3}$
Eq. D.17	$N_{sb} = 13 c_{a1} \sqrt{A_{brg} \lambda \sqrt{f'_c}}$	$N_{sb} = 42.5 c_{a1} \sqrt{A_{brg} \lambda \sqrt{f'_c}}$	$N_{sb} = 160 c_{a1} \sqrt{A_{brg} \lambda \sqrt{f'_c}}$
Eq. D.24	$V_b = 0.6 \left(\frac{\lambda_e}{d_a}\right)^{0.2} \sqrt{d_a} \lambda \sqrt{f'_c} (c_{a1})^{1.5}$	$V_b = 1.9 \left(\frac{\lambda_e}{d_a}\right)^{0.2} \sqrt{d_a} \lambda \sqrt{f'_c} (c_{a1})^{1.5}$	$V_b = 7 \left(\frac{\lambda_e}{d_a}\right)^{0.2} \sqrt{d_a} \lambda \sqrt{f'_c} (c_{a1})^{1.5}$
Eq. D.25	$V_b = 0.66 \left(\frac{\lambda_e}{d_a}\right)^{0.2} \sqrt{d_a} \lambda \sqrt{f'_c} (c_{a1})^{1.5}$	$V_b = 2.1 \left(\frac{\lambda_e}{d_a}\right)^{0.2} \sqrt{d_a} \lambda \sqrt{f'_c} (c_{a1})^{1.5}$	$V_b = 8 \left(\frac{\lambda_e}{d_a}\right)^{0.2} \sqrt{d_a} \lambda \sqrt{f'_c} (c_{a1})^{1.5}$
Sec 6.1.8.1	$E_c = w_c^{1.5} 0.043 \sqrt{f'_c}$ $E_c = 4700 \sqrt{f'_c}$	$E_c = w_c^{1.5} 0.14 \sqrt{f'_c}$ $E_c = 15,100 \sqrt{f'_c}$	$E_c = v_c^{1.5} 33 \sqrt{f'_c}$ $E_c = 57,000 \sqrt{f'_c}$
Sec 6.1.9.1	$\lambda = \frac{f_{ct}}{(0.56 \sqrt{f'_c})} \leq 1.0$	$\lambda = \frac{f_{ct}}{(1.78 \sqrt{f'_c})} \leq 1.0$	$\lambda = \frac{f_{ct}}{(6.7 \sqrt{f'_c})} \leq 1.0$
Sec 6.4.1.2	$\sqrt{f'_c} \leq 8.3 \text{ MPa}$	$\sqrt{f'_c} \leq 27 \text{ kgf/cm}^2$	$\sqrt{f'_c} \leq 100 \text{ psi}$

Reference	SI-metric stress in MPa	MKS-metric stress in kgf/cm ²	U.S. Customary unit stress in pounds per square inch (psi)
Sec 6.4.3.4.3	$0.33\sqrt{f'_c}b_wd$	$1.1\sqrt{f'_c}b_wd$	$4\sqrt{f'_c}b_wd$
Sec 6.4.3.5.1(f)	$0.17\phi\sqrt{f'_c}b_wd$	$0.53\phi\sqrt{f'_c}b_wd$	$2\phi\sqrt{f'_c}b_wd$
Sec 6.4.3.6.9	$0.66\sqrt{f'_c}b_wd$	$2.2\sqrt{f'_c}b_wd$	$8\sqrt{f'_c}b_wd$
Sec 6.4.4.1(a)	$T_u < 0.083\phi\lambda\sqrt{f'_c}\left(\frac{A_{cp}^2}{p_{cp}}\right)$	$T_u < 0.27\phi\lambda\sqrt{f'_c}\left(\frac{A_{cp}^2}{p_{cp}}\right)$	$T_u < \phi\lambda\sqrt{f'_c}\left(\frac{A_{cp}^2}{p_{cp}}\right)$
Sec 6.4.4.1(b)	$T_u < 0.083\phi\lambda\sqrt{f'_c}\left(\frac{A_{cp}^2}{p_{cp}}\right)\sqrt{1 + \frac{N_u}{0.33A_g\lambda\sqrt{f'_c}}}$	$T_u < 0.27\phi\lambda\sqrt{f'_c}\left(\frac{A_{cp}^2}{p_{cp}}\right)\sqrt{1 + \frac{N_u}{A_g\lambda\sqrt{f'_c}}}$	$T_u < \phi\lambda\sqrt{f'_c}\left(\frac{A_{cp}^2}{p_{cp}}\right)\sqrt{1 + \frac{N_u}{4A_g\lambda\sqrt{f'_c}}}$
Sec 6.4.4.2.2(a)	$T_u = \phi 0.33\lambda\sqrt{f'_c}\left(\frac{A_{cp}^2}{p_{cp}}\right)$	$T_u = \phi\lambda\sqrt{f'_c}\left(\frac{A_{cp}^2}{p_{cp}}\right)$	$T_u = \phi 4\lambda\sqrt{f'_c}\left(\frac{A_{cp}^2}{p_{cp}}\right)$
Sec 6.4.4.2.2(b)	$T_u = 0.33\phi\lambda\sqrt{f'_c}\left(\frac{A_{cp}^2}{p_{cp}}\right)\sqrt{1 + \frac{N_u}{0.33A_g\lambda\sqrt{f'_c}}}$	$T_u = \phi\lambda\sqrt{f'_c}\left(\frac{A_{cp}^2}{p_{cp}}\right)\sqrt{1 + \frac{N_u}{A_g\lambda\sqrt{f'_c}}}$	$T_u = 4\phi\lambda\sqrt{f'_c}\left(\frac{A_{cp}^2}{p_{cp}}\right)\sqrt{1 + \frac{N_u}{4A_g\lambda\sqrt{f'_c}}}$
Sec 6.4.5.5	$(3.3 + 0.08f'_c)A_c$ $11A_c$ $5.5A_c$	$(34 + 0.08f'_c)A_c$ $110A_c$ $55A_c$	$(480 + 0.08f'_c)A_c$ $1600A_c$ $800A_c$
Sec 6.4.6.3	$0.83\sqrt{f'_c}b_wd$	$2.65\sqrt{f'_c}b_wd$	$10\sqrt{f'_c}b_wd$
Sec 6.4.7.3.2.1	$(3.3 + 0.08f'_c)b_wd$ $11b_wd$	$(34 + 0.08f'_c)b_wd$ $110b_wd$	$(480 + 0.08f'_c)b_wd$ $1600b_wd$
Sec 6.4.7.3.2.2	$(5.5 - 1.9\frac{a_v}{d})b_wd$	$(55 - 20\frac{a_v}{d})b_wd$	$(800 - 280\frac{a_v}{d})b_wd$

Reference	SI-metric stress in MPa	MKS-metric stress in kgf/cm ²	U.S. Customary unit stress in pounds per square inch (psi)
Sec 6.4.8.3	$0.83\sqrt{f'_c}hd$	$2.65\sqrt{f'_c}hd$	$10\sqrt{f'_c}hd$
Sec 6.4.8.5	$0.17\lambda\sqrt{f'_c}hd$	$0.53\lambda\sqrt{f'_c}hd$	$2\lambda\sqrt{f'_c}hd$
Sec 6.4.10.3.1	$0.17\lambda\sqrt{f'_c}b_o d$	$0.53\lambda\sqrt{f'_c}b_o d$	$2\lambda\sqrt{f'_c}b_o d$
Sec 6.4.10.3.2	$0.5\sqrt{f'_c}b_o d$	$1.6\sqrt{f'_c}b_o d$	$6\sqrt{f'_c}b_o d$
Sec 6.4.10.4.8	$0.33\sqrt{f'_c}b_o d$ $0.58\sqrt{f'_c}b_o d$	$1.1\sqrt{f'_c}b_o d$ $1.9\sqrt{f'_c}b_o d$	$4\sqrt{f'_c}b_o d$ $7\sqrt{f'_c}b_o d$
Sec 6.4.10.5.1	$0.25\lambda\sqrt{f'_c}b_o d$ $0.66\sqrt{f'_c}b_o d$ $0.17\sqrt{f'_c}$	$0.8\lambda\sqrt{f'_c}b_o d$ $2.1\sqrt{f'_c}b_o d$ $0.53\sqrt{f'_c}$	$3\lambda\sqrt{f'_c}b_o d$ $8\sqrt{f'_c}b_o d$ $2\sqrt{f'_c}$
Sec 6.4.10.5.2	$0.5\phi\sqrt{f'_c}$	$1.6\phi\sqrt{f'_c}$	$6\phi\sqrt{f'_c}$
Sec 6.4.10.5.4 & Sec 6.4.10.7.2	$0.17\phi\lambda\sqrt{f'_c}$	$0.53\phi\lambda\sqrt{f'_c}$	$2\phi\lambda\sqrt{f'_c}$
Sec 6.4.10.7.3 & Sec 6.9.4.10	$0.33\phi\lambda\sqrt{f'_c}$	$1.1\phi\lambda\sqrt{f'_c}$	$4\phi\lambda\sqrt{f'_c}$
Sec 6.12.5.3.1 & Sec 6.12.5.3.2	$0.55b_v d$	$5.6b_v d$	$80b_v d$

Reference	SI-metric stress in MPa	MKS-metric stress in kgf/cm ²	U.S. Customary unit stress in pounds per square inch (psi)
Sec 6.12.5.3.3	$(1.8 + 0.6\rho_v f_y)\lambda b_v d \leq 3.5b_v d$	$(18 + 0.6\rho_v f_y)\lambda b_v d \leq 35b_v d$	$(260 + 0.6\rho_v f_y)\lambda b_v d \leq 500b_v d$
Sec 8.1.11.2(a)	$\frac{0.0018 \times 420}{f_y}$	$\frac{0.0018 \times 4200}{f_y}$	$\frac{0.0018 \times 60000}{f_y}$
Sec 8.2.2	$\sqrt{f'_c} \leq 8.3 \text{ MPa}$	$\sqrt{f'_c} \leq 26.5 \text{ kgf/cm}^2$	$\sqrt{f'_c} \leq 100 \text{ psi}$
Sec 8.2.3.2	$e_d = \left(\frac{f_y \psi_t \psi_e}{2.1 \lambda \sqrt{f'_c}} \right) d_b$ $e_d = \left(\frac{f_y \psi_t \psi_e}{1.7 \lambda \sqrt{f'_c}} \right) d_b$ $e_d = \left(\frac{f_y \psi_t \psi_e}{1.4 \lambda \sqrt{f'_c}} \right) d_b$ $e_d = \left(\frac{f_y \psi_t \psi_e}{1.1 \lambda \sqrt{f'_c}} \right) d_b$	$e_d = \left(\frac{f_y \psi_t \psi_e}{6.6 \lambda \sqrt{f'_c}} \right) d_b$ $e_d = \left(\frac{f_y \psi_t \psi_e}{5.3 \lambda \sqrt{f'_c}} \right) d_b$ $e_d = \left(\frac{f_y \psi_t \psi_e}{4.4 \lambda \sqrt{f'_c}} \right) d_b$ $e_d = \left(\frac{f_y \psi_t \psi_e}{3.5 \lambda \sqrt{f'_c}} \right) d_b$	$e_d = \left(\frac{f_y \psi_t \psi_e}{25 \lambda \sqrt{f'_c}} \right) d_b$ $e_d = \left(\frac{f_y \psi_t \psi_e}{20 \lambda \sqrt{f'_c}} \right) d_b$ $e_d = \left(\frac{3 f_y \psi_t \psi_e}{50 \lambda \sqrt{f'_c}} \right) d_b$ $e_d = \left(\frac{3 f_y \psi_t \psi_e}{40 \lambda \sqrt{f'_c}} \right) d_b$
Sec 8.2.4.2	$\left(\frac{0.24 f_y}{\lambda \sqrt{f'_c}} \right) d_b \geq (0.043 f_y) d_b$	$\left(\frac{0.075 f_y}{\lambda \sqrt{f'_c}} \right) d_b \geq (0.0044 f_y) d_b$	$\left(\frac{0.02 f_y}{\lambda \sqrt{f'_c}} \right) d_b \geq (0.0003 f_y) d_b$
Sec 8.2.6.2	$e_{dh} = \left(\frac{0.24 \psi_e f_y}{\lambda \sqrt{f'_c}} \right) d_b$	$e_{dh} = \left(\frac{0.075 \psi_e f_y}{\lambda \sqrt{f'_c}} \right) d_b$	$e_{dh} = \left(\frac{0.02 \psi_e f_y}{\lambda \sqrt{f'_c}} \right) d_b$
Sec 8.2.7.5(b)	$0.41 \frac{b_w s}{f_{yt}}$	$4.2 \frac{b_w s}{f_{yt}}$	$60 \frac{b_w s}{f_{yt}}$
Sec 8.2.10.2(b)	$0.17 \frac{d_b f_{yt}}{\lambda \sqrt{f'_c}}$	$0.053 \frac{d_b f_{yt}}{\lambda \sqrt{f'_c}}$	$0.014 \frac{d_b f_{yt}}{\lambda \sqrt{f'_c}}$

Reference	SI-metric stress in MPa	MKS-metric stress in kgf/cm ²	U.S. Customary unit stress in pounds per square inch (psi)
Sec 8.2.14.1	$0.071f_y d_b$ $(0.13f_y - 24)d_b$	$0.0073f_y d_b$ $(0.013f_y - 24)d_b$	$0.0005f_y d_b$ $(0.0009f_y - 24)d_b$
Sec 8.2.17.2	$e_{dt} = \left(\frac{0.19\psi_e f_y}{\sqrt{f'_c}}\right) d_b$	$e_{dt} = \left(\frac{0.06\psi_e f_y}{\sqrt{f'_c}}\right) d_b$	$e_{dt} = \left(\frac{0.016\psi_e f_y}{\sqrt{f'_c}}\right) d_b$
Sec 8.2.18.2	$\left(\frac{f_y - 240}{f_y}\right)$	$\left(\frac{f_y - 2460}{f_y}\right)$	$\left(\frac{f_y - 35,000}{f_y}\right)$
Sec 8.3.4.2(a)	$\frac{1.4b_w d}{f_y}$	$\frac{14b_w d}{f_y}$	$\frac{200b_w d}{f_y}$
Sec 8.3.5.4 & Figure 6.8.8	$s_o = 100 + \left(\frac{350 - h_x}{3}\right)$ 100 mm ≤ s _o ≤ 150 mm	$s_o = 10 + \left(\frac{35 - h_x}{3}\right)$ 10 cm ≤ s _o ≤ 15 cm	$s_o = 4 + \left(\frac{14 - h_x}{3}\right)$ 4 in. ≤ s _o ≤ 6 in.
Sec 8.3.6.2(a)	$0.083A_{cv}\lambda\sqrt{f'_c}$	$0.27A_{cv}\lambda\sqrt{f'_c}$	$A_{cv}\lambda\sqrt{f'_c}$
Sec 8.3.6.2(b)	$0.17A_{cv}\lambda\sqrt{f'_c}$	$0.53A_{cv}\lambda\sqrt{f'_c}$	$2A_{cv}\lambda\sqrt{f'_c}$
Sec 8.3.6.6	$2.8/f_y$	$28/f_y$	$400/f_y$
Sec 8.3.6.7 (b)	$0.33\lambda\sqrt{f'_c}A_{cw}$	$\lambda\sqrt{f'_c}A_{cw}$	$4\lambda\sqrt{f'_c}A_{cw}$
Sec 8.3.7.3	$1.7\sqrt{f'_c}A_j$ $1.2\sqrt{f'_c}A_j$ $1.0\sqrt{f'_c}A_j$	$5.3\sqrt{f'_c}A_j$ $4\sqrt{f'_c}A_j$ $3.2\sqrt{f'_c}A_j$	$20\sqrt{f'_c}A_j$ $15\sqrt{f'_c}A_j$ $12\sqrt{f'_c}A_j$

Reference	SI-metric stress in MPa	MKS-metric stress in kgf/cm ²	U.S. Customary unit stress in pounds per square inch (psi)
Sec 8.3.8.3(f)	$0.67A_{cv}\sqrt{f'_c}$ $0.83A_{cp}\sqrt{f'_c}$	$2.12A_{cv}\sqrt{f'_c}$ $2.65A_{cp}\sqrt{f'_c}$	$8A_{cv}\sqrt{f'_c}$ $10A_{cp}\sqrt{f'_c}$
Sec 8.3.8.3(g)	$0.83A_{cp}\sqrt{f'_c}$	$2.65A_{cp}\sqrt{f'_c}$	$10A_{cp}\sqrt{f'_c}$
Sec 8.3.12.4	$0.29\sqrt{f'_c}b_o d$	$0.93\sqrt{f'_c}b_o d$	$3.5\sqrt{f'_c}b_o d$
Table 6.6.1	$(1.65 - 0.0003w_c) \geq 1.09$ $\left(0.4 + \frac{f_y}{700}\right)$	$(1.65 - 0.0003w_c) \geq 1.09$ $\left(0.4 + \frac{f_y}{7000}\right)$	$(1.65 - 0.005w_c) \geq 1.09$ $\left(0.4 + \frac{f_y}{100,000}\right)$

PART VI
Appendix B**Local Geology, Tectonic Features and Earthquake Occurrence in the Region**

B.1 Seismotectonics and Earthquake Occurrence in and Around Bangladesh

B.1.1 General

Earthquakes are closely related to plate tectonics. Bangladesh is located in a tectonically active region close to the plate boundaries of the Indian plate and the Eurasian plate. The plate boundaries lie to the north and east of Bangladesh. The collision of the north-east moving (around 4 cm or more annually) Indian Plate with the Eurasian plate (Figure 6.B.1) is the cause of frequent earthquakes in the region comprising North East India, Nepal, Bhutan, Bangladesh and Myanmar.

Major thrust faults exist to the north (at the foot of the Himalayas) and to the east (in the Indo-Burma mountain ranges) of Bangladesh. Geologic evolution of the Bengal Basin is related to this collision. Bangladesh constitutes the major portion of the Bengal Basin. The collision perhaps started in the late Cretaceous and the Bay of Bengal and the Bengal Basin attained its present configuration at the end of middle Miocene orogeny.

Tectonically Bangladesh is divided broadly into three divisions: (i) Stable Shelf (in the northwest) (ii) Bengal Foredeep (in the Central) and (iii) Chittagong-Tripura Folded Belt (in the east). In addition there is a SW-NE trending 25 km wide hinge zone separating the Bengal Foredeep from the Stable Shelf.

The Stable Pre-Cambrian Shelf in the northwest consists of relatively thin sedimentary strata over bedrock. In Madhyapara area of Dinajpur the basement is only 130 m deep from the ground surface and is overlain by Dupi Tila Sandstone and Madhupur Clay of Plio-Pliocene age. The basement plunges gently from Madhyapara towards the southeast up to the Hinge Zone. Seismic contours on top of limestone in Bogra show regional dip of 2-3° besides revealing a number of NE-SW trending faults. The hinge zone is characterized by the sharp change in the dip of the basement rocks associated with deep-seated displacements in faults and is reflected on the gravity and magnetic anomalies. In the hinge zone, the depth of the limestone increases from 4000m to 9000m within a narrow zone of 25-km. Hinge Zone is connected with Bengal Foredeep by deep basement faults that probably started with the breakup of Gondwanaland. The SW-NE trending Hinge Zone turns to the east near Indian border in Jamalpur and seems to be connected with the Dauki Fault, probably by a series of east-west trending faults. Bengal Foredeep occupies the vast area between Hinge Line and Arakan Yoma Folded System in the east. The Bengal

Foredeep consists of very thick basin-fill that overlies deeply subsided basement of undetermined origin in the south and east. Thickness of sediments increase toward the south and east to more than 16 km. The huge thickness of sediments in the basin is a result of tectonic mobility or instability of the areas causing rapid subsidence and sedimentation in a relatively short span of geologic time. The Bengal Foredeep consists of some Troughs and some relatively high lands. Faridpur Trough situated adjacent to Hinge Zone is separated from the Sylhet Trough (in the northeast) by the Madhupur High of Pleistocene origin where the basement is relatively uplifted. East-west trending Dauki Fault with 5 km wide fault zone near Bangladesh-India border forms the contact between Shillong Massif (India) and Sylhet Trough. Eastern part of the country is represented by the Chittagong-Tripura Folded Belt. The folded belt in the east consists of narrow, elongated N-S trending folds in Sylhet and Chittagong Divisions of Bangladesh, Tripura, southern Assam and Mizoram states in India and also Myanmar territory. The elevation of these elongated anticlinal folds in Bangladesh ranges from 100 -1,000m. Some of the structures are faulted and thrust and the intensity of folding increases gradually from west to east.

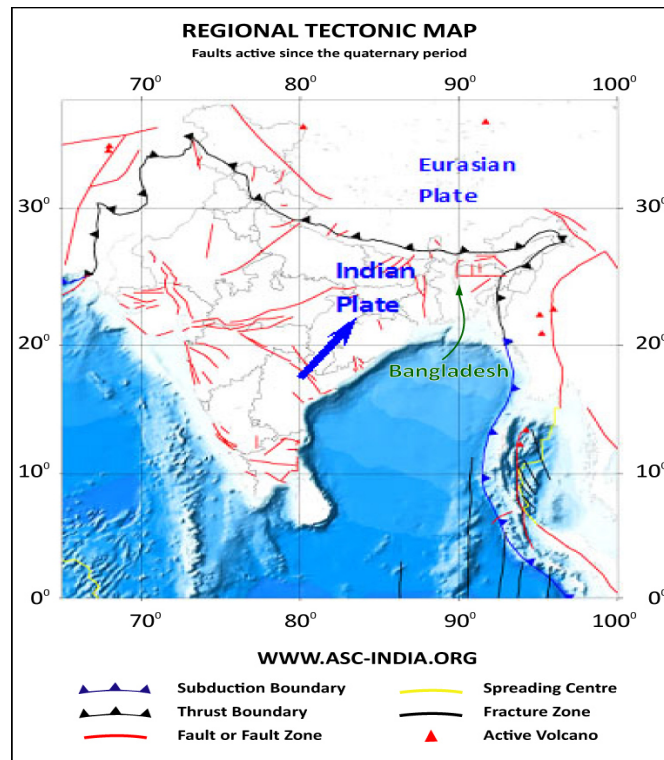


Figure 6.B.1 Movement of Indian plate relative to Eurasian plate

B.1.2 Earthquake Occurrence

Historically Bangladesh has been affected by five earthquakes of large magnitude ($M \geq 7.0$) during 1869 to 1930. One of the strongest earthquakes of the world, the 12 June 1897 Great Indian earthquake in Shillong, Assam had an epicentral distance of about 230 km from Dhaka, its magnitude has recently been reestimated to be 8.1. Two of these earthquakes had their epicenters within the country. The 14 July 1885 Bengal earthquake, measured as $M = 7.0$, originated near Bogra in Bangladesh. The 8 July 1918 Srimongal earthquake occurred in Sylhet region of Bangladesh and its magnitude was determined as $M_s = 7.6$. In addition, some historical reporting points out to the occurrence of a major earthquake ($M > 7$) near Chittagong in 1762. Table 6.B.1 gives brief information about these major earthquakes.

In recent years, the occurrence and damage caused by a number of earthquakes (magnitude between 4 and 6) inside the country or near the country's border, has raised an alarm. The Nov. 21, 1997 magnitude 6.0 earthquake at the Bangladesh-Myanmar border triggered collapse of an under-construction reinforced concrete frame building that killed several people in the port city of Chittagong. The July 22, 1999 magnitude 5.1 earthquake with its epicenter very near the island of Moheshkhali, near Cox's Bazar, caused extensive damage and collapse of rural mud-walled houses, as well as damaging column of cyclone shelter. The Dec. 2001 magnitude 4.0+ earthquake with its epicenter very near Dhaka city caused panic and injuries to prison inmates at the Dhaka central Jail. In the July 27, 2003 magnitude 5.6 Rangamati earthquake, in the village of Kolabunia, brick masonry buildings as well as mud-walled houses were severely damaged.

Table 6.B.1: List of Major Regional Earthquakes

Date	Earthquake name	Epicentre	Magnitude, M	Effects
2 April, 1762	---	Near Chittagong	>7.0	Some changes in landforms in the coastal area and liquefaction
10 Jan. 1869	Cachar	Cachar, Assam	7.5	Some damage occurred in Sylhet
14 Jul. 1885	Bengal	Bogra	7.0	Severe damage occurred to houses in Sirajganj and Sherpur (Bogra)
12 Jun. 1897	Great Indian	Shillong, Assam	8.1	Greatest damage in Rangpur including railway line and buildings; intense ground fissures and vents in Mymensingh, Jamalpur, Sylhet; damages to masonry buildings covering a major portion of Bangladesh including Dhaka

Date	Earthquake name	Epicentre	Magnitude, M	Effects
8 Jul. 1918	Srimongal	Srimongal, Sylhet	7.6	Collapse/ severe damage of buildings in Srimongal, damage to buildings in Habiganj, Moulvibazar
2 Jul. 1930	Dhubri	Garo hills	7.1	Damage to railway track in Lalmonirhat, damage to buildings in Lalmonirhat and Rangpur

Figure 6.B.2 shows distribution of earthquake ($M \geq 3.5$) epicenters for the period 1845-Feb.2010 in and around Bangladesh. This is indicative of the significant seismic activity in the region. There are earthquakes distributed all over Bangladesh. However the cluster of earthquakes appears to be quite dense in Chittagong. Although few in number, there are earthquakes occurring in south western Bangladesh including the sea. The large magnitude ($M \geq 7.0$) earthquakes have taken place within Bangladesh in Sylhet, Bogra, and Chittagong. Outside Bangladesh but close enough to cause damage in Bangladesh, major earthquakes ($M \geq 7.0$) have occurred in India to the north, northeast and northwest of Bangladesh particularly affecting Sylhet, Mymensingh and Rangpur region.

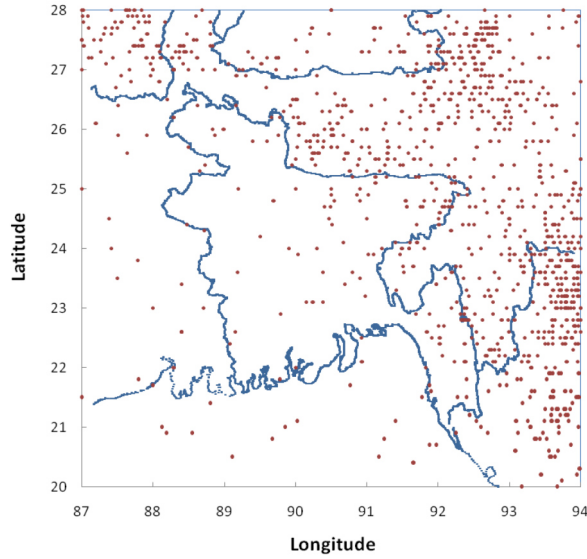


Figure 6.B.2 Earthquake ($M \geq 3.5$) occurrence in and around Bangladesh (1845-Feb.2010).

PART VI
Appendix C

Seismic Design Parameters for Alternative Method of Base Shear Calculation

Table 6.C.1: Spectral Response Acceleration Parameter S_s and S_1 for Different Seismic Zone

Parameters	Zone-1	Zone-2	Zone-3	Zone-4
S_s	0.3	0.5	0.7	0.9
S_1	0.12	0.2	0.28	0.36

Table 6.C.2: Site Coefficient F_a for Different Seismic Zone and Soil Type

Soil Type	Zone-1	Zone-2	Zone-3	Zone-4
SA	1.0	1.0	1.0	1.0
SB	1.2	1.2	1.2	1.2
SC	1.15	1.15	1.15	1.15
SD	1.35	1.35	1.35	1.35
SE	1.4	1.4	1.4	1.4

Table 6.C.3: Site Coefficient F_v for Different Seismic Zone and Soil Type

Soil Type	Zone-1	Zone-2	Zone-3	Zone-4
SA	1.0	1.0	1.0	1.0
SB	1.5	1.5	1.5	1.5
SC	1.725	1.725	1.725	1.725
SD	2.7	2.7	2.7	2.7
SE	1.75	1.75	1.75	1.75

Table 6.C.4: Spectral Response Acceleration Parameter S_{DS} for Different Seismic Zone and Soil Type

Soil Type	Zone-1	Zone-2	Zone-3	Zone-4
SA	0.2	0.333	0.466	0.6
SB	0.24	0.4	0.56	0.72
SC	0.23	0.383	0.536	0.69
SD	0.27	0.45	0.63	0.81
SE	0.28	0.466	0.653	0.84

Table 6.C.5 Spectral Response Acceleration Parameter S_{D1} for Different Seismic Zone and Soil Type

Soil Type	Zone-1	Zone-2	Zone-3	Zone-4
SA	0.08	0.133	0.186	0.24
SB	0.12	0.2	0.28	0.36
SC	0.138	0.23	0.322	0.414
SD	0.216	0.36	0.504	0.648
SE	0.14	0.233	0.326	0.42

**PART VI
Appendix D****Methods of Soil Exploration, Sampling and Groundwater Measurements****D.1 Methods of Soil Exploration**

The detailed methods of soil investigation usually include collecting undisturbed samples and or performing field tests. Listed below are some of the common methods of subsoil exploration.

D.1.1 Open Trial Pits

In this method trial pits are excavated exposing the subsoil thoroughly. Undisturbed samples are taken from intact sides and bottom of the trial pits. This is suitable for all types of formation but for cuts which cannot stand below water table, proper bracing shall be provided. This method is normally used for shallow depths (up to 3 m). Test pits are usually prepared by hand excavation which allows access for a full observation and description of the soil profile. Hand-cut samples known as block or chunk samples can be obtained from the test pit. In stiff clays it provides fairly accurate idea of the depth of open excavations or vertical cuts. It also provide better picture of the patchy ground where the soil lies in pockets

D.1.2 Auger Boring

Augers, hand or power operated, are rotated and forced into soil. Augers are withdrawn and emptied when full. Soil cuttings obtained are used to interpret stratification and soil type. The method is unsatisfactory for cohesionless soils above or below ground water.

D.1.3 Shell and Auger Boring

Manual or mechanized rigs are used for vertical boring. The tools consist of auger for soft to stiff clays, shells for very stiff to hard clays, shells or sand pumps attached to sectional boring rods for sandy strata. Hand operated auger can be used up to depths of 18 m to 21 m in stiff clay. Mechanically operated tools are required for higher depths. An auger is used for boring holes to a depth of about 6 m in soft soil. Soft to stiff clays are removed by a cylindrical auger. Hard clays and cohesionless deposits are removed by a shell. The soil recovered contains all constituent. Bailers are be used to remove soil cuttings. Care is taken while withdrawing the shell to avoid sand boiling. Special care is taken to minimize soil disturbance below borehole. The advantages of shell and auger boring are as follows:

- (i) Easy to identify the soil
- (ii) Easy to note changes in strata
- (iii) Soil profile and depths undisturbed sampling can be determined with greater accuracy
- (iv) Boring in partially saturated materials above the ground water level
- (v) Determination of ground water level is relatively easy

D.1.4 Wash Boring

In this method, soil is loosened by chopping and cutting by impact and twisting action of a lightweight bit. Soil is removed from the borehole by a stream of water or drilling mud from lower end of the wash pipe which is worked up and down or rotated into the borehole. The water or mud flow carries the soil through the annular space between the wash pipe and casing and is overflowed at ground level. The soil in suspension is allowed to settle in a pond or tank and the fluid is recirculated as required. The soil brought to surface by the wash water can be used for identification purposes but is not representative of the character and consistency of the material penetrated and the flushing water may disturb the surrounding ground. Subsoil can be identified thoroughly if field tests (viz. Standard Penetration Test) are performed and or undisturbed samples are collected frequently.

D.1.5 Sounding/Probing

A number of sounding methods are available. The most common is the Standard Penetration Test (SPT). The SPT test is specified in ASTM D1586 and ASTM D6066. Other methods include procedures like Cone Penetration Test (CPT) and Dynamic Probing (DP). Sounding/probing may be done in conjunction with inhole tests such as "Field Vane Shear Test in Cohesive Soil", (ASTM D2573), bore-hole shear (Iowa Bore-hole Shear) Test, Flat Dilatometer Test (DMT) or "Prebored Pressuremeter Testing in Soils", (ASTM D4719).

D.1.6 Geophysical Methods

Geophysical survey techniques are based on determining variations in physical properties, such as electrical conductivity (resistivity), variation in density (gravimetric), magnetic susceptibility (magnetic) or velocity of sonic waves (seismic). Anomalies such as near surface disturbance (often known as noise) are common in urban environment and may limit the usefulness of geophysics in these areas. Moreover, a geophysical anomaly does not always match an engineering or geological boundary, and often there is a transition zone at a boundary. These may lead to a margin of uncertainty.

D.1.7 Percussion Boring

In percussion drilling method borehole is advanced by chopping action of a heavy bit driven by power. Drilling is performed raising and dropping a heavy drilling bit. The borehole is generally kept dry. Water is added at the bottom of the borehole during chopping action, if ground water is not already struck. Slurry formed at the bottom of hole is removed by bailer or sand pump. Casing may be needed. This method is Simple to operate and suitable for drilling bore holes in deposits of gravels and boulders. However, using this method, determination of the changes in the soil strata is very difficult. The method is relatively slow and not economical for boring diameter less than 100 mm

D.1.8 Rotary Drilling

In rotary drilling, borehole is advanced by power rotation of drilling bit. The particles from inside is removed by circulating fluids which may be water, bentonite slurry or mud slurry in a manner similar to that in wash boring. Casing may or may not be needed during drilling. This method is particularly suitable for very hard formation and rock. Rate of progress is fast. Difficult to detect changes in strata

D.2 Choice of Method

The choice of a method of soil exploration depends upon:

- (i) The topography, type of ground to be investigated and ground water conditions;
- (ii) The type of building envisaged and technical requirements;
- (iii) Amount of existing information;
- (iv) Expected variability of soil;
- (v) External constraints such as availability of plant, access, cost and time.

The technical requirements of the investigation rather than cost should be the overriding factor in the selection of exploration method. In clayey soils, borings are suitable for deep exploration and pit for shallow exploration. In sandy soils special equipment are needed for taking representative samples below the water table. Ground investigation is normally done by boreholes, but where only shallow depths are to be investigated, and where ground water problems are not envisaged, trial pits may prove more versatile and economical. Boreholes may be necessary on waterlogged sites where it is impracticable to excavate trial pits without dewatering.

Safety aspects must be considered when selecting and carrying out exploration. Precautions relating to safety, health and welfare of workmen, hazards from underground services, contaminated ground and inspection pits or shafts shall be undertaken. Overhead power lines are a hazard if ground investigation rigs are to operate in the vicinity.

D.3 Sample Disturbance and Sampling Methods

The major purposes of retrieving soil sample from ground are as follows:

- (i) Inspection of the material and to describe its fabric
- (ii) To classify the material by index tests
- (iii) Determination of mechanical properties, such as, stress-strain-strength-stiffness, compressibility and expansibility, and permeability

Samples shall contain all the mineral constituents of the strata from which they have been taken. They shall not be contaminated by any material from other strata or from additives used during the sampling procedure. For index tests, the sample should be intact in terms of its constituents, and changes in fabric and stress state are acceptable. To measure most mechanical properties the sample needs to be undisturbed and representative. Material submitted for testing should be representative of the mass which will be affected by construction and the level of sample disturbance should be acceptable.

The physical process of obtaining samples has been recognized as a prime cause of sample disturbance. The main causes of sampling disturbance are as follows:

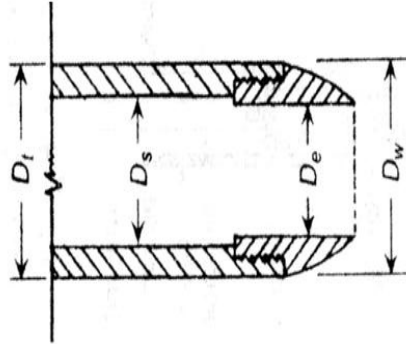
- (i) Disturbance of the soil to be sampled before the beginning of sampling as a result of poor drilling operation leading to swelling, compaction, base heave, piping and caving
- (ii) Mechanical distortion during the penetration of the sampling tube into the soil. This is referred as tube penetration disturbance
- (iii) Mechanical distortion and suction effects during the retrieval of the sampling tube.
- (iv) Release of total in situ stresses.
- (v) Disturbance of the soil during transportation, storage and sample preparation.

The first cause can be reduced by sampling with properly cleaned boreholes advanced by using bentonite slurry. The second and third causes are directly associated with sampler design and can be controlled to certain extent. The fourth cause is unavoidable even though its effects may be different depending on the depth of sampling and soil properties. The fifth cause can be reduced by storing samples for minimum time in controlled atmosphere and careful handling of samples during transportation and preparation.

The design of a sampler is one of the most important factors that should be considered for quality sampling. The amount of disturbance varies considerably depending upon the dimensions of the sampler and the precise geometry of the cutting shoe of the sampler. Hvorslev (1949) discussed at length the importance of the design of a sampler and introduced the concepts of area ratio, inside and outside clearance ratio and cutting edge taper angle in controlling sampling disturbance. Terms used to define geometry of cutting shoe of a tube sampler is shown in Figure 6.D.1.

Increasing area ratio gives increased soil disturbance and remoulding. The penetration resistance of the sampler and the possibility of the entrance of excess soil also increase with increasing area ratio. For soft clays, area ratio is kept to a minimum by employing thin-walled tubes. For composite samplers, the area ratio, however⁶, is considerably higher. In these cases, sample disturbance is reduced by tapering the outside of the sampler tube very gradually from a sharp cutting edge (Hvorslev, 1949, recommended a

maximum 10°), so that the full wall thickness is far removed from the point where the sample enters the tube. The combined requirements for area ratio and cutting edge taper angle to cause low degree of disturbance and the optimum length to diameter ratios for clays of different sensitivities were proposed by ISSMFE’s sub-committee on Problems and Practices of Soil Sampling.



$$\text{Area ratio, } Ar = \frac{D_w^2 - D_e^2}{D_e^2}$$

$$\text{Inside Clearance ratio, } ICR = \frac{D_s - D_e}{D_e}$$

$$\text{Outside Clearance Ratio, } OCR = \frac{D_w - D_t}{D_t}$$

Figure 6.D.1 Dimensions of a tube sampler and terms used to define geometry of cutting

Tube sampler characteristics suggested by ISSMFE (1965) is presented in Table 6.D.1. Inside wall friction is one of the principal causes of disturbance of the sample (Hvorslev, 1949). One of the methods of reducing or eliminating wall friction between the soil and sampler is to provide inside clearance by making the diameter of the cutting edge, D_e , slightly smaller than the inside diameter of the sampler tube, D_s . Inside clearance gives the soil sample room for some swelling and lateral strain due to horizontal stress reduction. Although neither of these types of behaviour is desirable, they are less undesirable than the consequences of adhesion between the soil and the inside of the sampler tube (Clayton et al, 1982).

Table 6.D.1: Tube Sampler Characteristics (after ISSMFE, 1965)

Area ratio/cutting-edge taper*	
Leading edge	
60° taper angle:	
<ul style="list-style-type: none"> • up to a thickness of 0.3 mm for cohesive soils • up to a thickness of D_{10} in granular soils 	
Cutting shoe	
Area ratio (%)	Taper angle (degrees)
5	15
10	12
20	9
40	5
80	4
Inside clearance ratio/length-to-diameter (L/D) ratio ⁺	

Soil type	Greatest permissible L/D ratio
Clay (sensitivity > 30)	20
Clay (sensitivity 5-30)	12
Clay (sensitivity <5)	10
Loose frictional soil	12
Medium loose frictional soil	6

* Suggested for samplers of about 75 mm diameter.

+ For samplers with smooth and clean inside surfaces, and with an inside clearance ratio of 0.5-1.0%.

Inside clearance should be large enough to allow partial swelling and lateral stress reduction but it should not allow excessive soil swelling or loss of the sample when withdrawing from the sampling tube. Hvorslev (1949) suggests an inside clearance ratio of 0.75 to 1.5% for long samplers and 0 to 0.5% for very short samplers. Kallstenius (1958) on the basis of Swedish clays sampled by six different piston samplers and also recommends that a sampler have a moderate inside clearance. The clearance reduces the wall friction and probably counteracts to a certain extent the disturbance from displacement of soil caused by the edge and sampler wall during the driving operation. If the inside clearance and the edge angle are moderate, the above positive effects outweigh the disturbance caused by deformation when the sample tends to fill the clearance. In order to reduce outside wall friction, samplers are often provided with outside clearance. An outside clearance ratio of a few per cent may decrease the penetration resistance of samplers in cohesive soils. Although outside clearance increases the area ratio, a clearance of 2 to 3% can be advantageous in clay (Hvorslev, 1949).

The recommended criteria for high quality sampling areas follow:

- (i) Area ratio : less than 10%
- (ii) ICR = 0 to 0.5 % for very short samplers; ICR = 0.75 to 1.5 % for long samplers
- (iii) OCR : not more than 2 to 3%

For 50 to 75 mm diameter samplers:

- (i) L/D_i ratio: not more than 5 to 10 for loose to dense cohesionless soils (D_i = Internal diameter of sampling tube)
- (ii) L/D_i ratio: not more than 10 to 20 for very soft to stiff cohesive soils

Samples retrieved from can be classified into the following types:

- (i) Representative
- (ii) Non-representative
- (iii) Undisturbed
- (iv) Disturbed

A representative sample is one in which the fabric and structure of the soil in situ is fully represented. A non-representative sample is which does not the grading, fabric and structure of the soil in situ.

An undisturbed sample is one, which represents as practicable the true in situ structure and moisture content of the soil. Truly, undisturbed samples cannot be taken from boreholes, and in practice there are only differing levels of disturbed samples. Material may be secured in open tube samplers for clays except of firm or of stiff consistency. For softer clays stationary piston samplers of low area ratio, shall be used and careful boring and sample preservation technique shall be employed. The minimum diameter of undisturbed sample shall be 40 mm with minimum length/diameter ratio of 3.

A disturbed sample is one which preserves the grading of the in situ soil but in which the soil structure is significantly damaged or completely destroyed and the moisture content also changed considerably from the in situ value

Sample quality is dependent on type of soil being sampled, type and condition of equipment and the skill with which it is used. The weaker material is the most significant in an investigation, and is usually difficult to secure in an undisturbed condition. It is rarely possible to sample granular (non-cohesive) materials in undisturbed condition, unless special techniques are used. Granular soil conditions are usually assessed by in-situ tests and confirmed by disturbed samples which permit classification and grading analysis and visual inspection. Cohesive soils may be tested both in-situ and in laboratory on undisturbed or relatively undisturbed samples.

The sample and/or test locations must be such that all changes of stratum are recorded. A number of extra samples and test results are usually required to assess variation of the properties of a stratum with depth. The record of all borings shall include the following information:

- (a) Size of casing (if used),
- (b) Number of blows per 300 mm required to drive the sampling spoon,
- (c) The elevation of the ground surface referred to an established datum,
- (d) Location and depth of boring and its relation to the proposed construction,
- (e) Elevation at which samples were taken,

- (f) Elevation of the boundaries of soil strata,
- (g) Description of the soil strata encountered and any particular unusual or special condition such as loss of water in the earth and rock strata, presence of boulders, cavities and obstructions, use of special type of samplers, traps, etc., and,
- (h) The level of ground water together with a description of how and when it was observed.

All abandoned and unsuccessful attempts of borings or drillings shall also be reported. In complex formations, details of sampling are necessary and, therefore, separate holes may be employed purely for sampling or testing, termed as “double hole sampling”.

Care shall be taken in protecting, handling, labelling and subsequently transporting the samples, so that samples can be received in a fit state for examination and testing, and can be correctly recognized as coming from a specific trial pit or boring.

Soil samples for laboratory tests can be divided in five quality classes with respect to the soil properties that are assumed to remain unchanged during sampling and handling, transportation and storage. The classes are described in Table 6.D.2. Class 1 and Class 2 samples listed in Table G-2 are generally referred to as 'undisturbed' while Classes 3, 4, and 5 as 'disturbed' samples. The amount of sample generally required for testing purposes is given in Table 6.D.3.

Table 6.D.2: Categories of Soil Samples Based on Quality

Quality	Recommended use of Sample
Class 1	Stratigraphy, Stratification, Atterberg limits, particle size, moisture content, organic content, unit weight, relative density/density index, porosity, permeability, shear strength and compressibility.
Class 2	Stratigraphy, Stratification, Atterberg limits, particle size, moisture content, organic content, unit weight, relative density/density index, porosity and permeability.
Class 3	Stratigraphy, Stratification, Atterberg limits, particle size, moisture content and organic content.
Class 4	Stratigraphy, Stratification, Atterberg limits, particle size and organic content.
Class 5	Stratigraphy and Stratification.

Table 6.D.3: Weight of Soil Sample Required for Laboratory Tests

Purpose of Sample	Type of Soil	Weight of Sample Required, kg.
Soil identification, natural moisture content test, mechanical analysis and index properties	Cohesive soil	1
	Sand and gravel	3
Chemical test	Cohesive soil	2
	Sand and gravel	3
Compaction test	Cohesive soil and sand	12.5
	Gravelly soil	25
Comprehensive examination of construction materials including stabilization	Cohesive soil and sand	25 to 50
	Gravelly soil	50 to 100

D.4 Ground Water Measurements in Soil

Groundwater investigations shall provide all relevant information on groundwater needed for geotechnical design and construction. Groundwater investigations should provide, when appropriate, information on:

- (i) the depth, thickness, extent and permeability of water-bearing strata in the ground
- (ii) the elevation of the groundwater surface or piezometric surface of aquifers and their variation over time and actual groundwater levels including possible extreme levels and their periods of recurrence
- (iii) the pore water pressure distribution
- (iv) the chemical composition and temperature of groundwater.

The information obtained should be sufficient to assess the following aspects, where relevant:

- (i) the scope for and nature of groundwater-lowering work
- (ii) possible harmful effects of the groundwater on excavations or on slopes (e.g. risk of hydraulic failure, excessive seepage pressure or erosion)
- (iii) any measures necessary to protect the structure (e.g. waterproofing, drainage and measures against aggressive water)
- (iv) the effects of groundwater lowering, desiccation, impounding etc. on the surroundings
- (v) the capacity of the ground to absorb water injected during construction work

The determination of the groundwater table or pore water pressures in soils and rocks shall be made by installing open or closed groundwater measuring systems into the ground. The type of equipment to be used for groundwater measurements shall be selected according to the type and permeability of ground, the purpose of the measurements, the required observation time, the expected groundwater fluctuations and the response time of the equipment and ground.

There are two main methods for measuring the groundwater pressure; open systems and closed systems. In open systems the piezometric groundwater head is measured by an observation well, usually provided with an open pipe. In closed systems the groundwater pressure at the selected point is directly measured by a pressure transducer. Open systems are best suited for soils and rock with a relatively high permeability (aquifers and aquitards), e.g. sand and gravel or highly fissured rock. With soils of low permeability they may lead to erroneous interpretations, due to the time lag for filling and emptying the pressure pipe. The use of filter tips connected to a small diameter hose in open systems, decreases the time lag. Closed systems can be used in all types of soil. They should be used in very low permeability soils. Closed systems are also recommended when dealing with high artesian water pressure. When short term variations or fast pore water fluctuations are to be monitored, continuous recording shall be used by means of transducers and data loggers.

In cases where open water is situated within or close to the investigation area, the water level shall be considered in the interpretation of the groundwater measurements. The water level in wells, the occurrence of springs and artesian water shall also be noted.

The number, location and depth of the measuring stations shall be chosen considering the purpose of the measurements, the topography, the stratigraphy and the soil conditions, especially the permeability of the ground or identified aquifers.

For monitoring projects e.g. groundwater lowering, excavations, fillings and tunnels, the location shall be chosen with respect to the expected changes to be monitored. For reference purposes, measurement of the natural fluctuations in ground water should be made, if possible, outside the area affected by the actual project. The number and frequency of readings and the length of the measuring period for a given project shall be planned considering the purpose of the measurements and the stabilization period.

If it is intended to assess groundwater fluctuations, measurements shall be taken at intervals smaller than the natural fluctuations to be characterized and over a long period of time.

During the drilling process, the observation of the water level at the end of the day and the start of the following day (before the drilling is resumed) is a good indication of the groundwater conditions and should be recorded. Any sudden inflow or loss of water during drilling should also be recorded, since it can provide additional useful information during the first phases of site investigations, some of the boreholes may be equipped with open perforated pipes protected with filters. The water level readings obtained during the following days yield a preliminary indication of groundwater conditions.

The evaluation of groundwater measurements shall take into account the geological and geotechnical conditions of the site, the accuracy of individual measurements, the fluctuations of pore water pressures with time, the duration of the observation period, the season of measurements and the climatic conditions during and prior to that period. The evaluated results of groundwater measurements shall comprise the observed maximum and minimum elevations of the water table, or pore pressures and the corresponding measuring period. If applicable, upper and lower bounds for both extreme and normal circumstances shall be derived from the measured values, by adding or subtracting the expected fluctuations or a reduced part of them, to the respective extreme or normal circumstances. The frequent lack of reliable data for extended periods of time of this type of measurements will necessitate the derived values being a cautious estimate based on the limited available information. The need for making further measurements or installing additional measuring stations should be assessed during the field investigations and in the geotechnical investigation report.

D.5 Standard Penetration Test

The Standard Penetration Test (SPT) is widely used to determine the in-situ properties of soil. The test is especially suited for cohesionless soils as the correlation between the SPT value and ϕ is now well established. The standard test methods are provided in ASTM D156 and ASTM D6066.

The test consists of driving a split spoon sampler, Figure 6.D.2, into soil through a borehole of 55 to 100 mm in diameter at the desired depth. It is done by a hammer weighing 65 kg (140 lb) dropping onto a drill rod from a height of 750 mm (30 inch). The number of blows N required to produce a penetration of 300 mm (12 inches) is regarded as the penetration resistance. To avoid seating errors, the blows for the first 150 mm (6 inches) of penetration are not taken into account; those required to increase the penetration from 150 mm to 450 mm constitute the N -value. A demonstration of Standard Penetration Test is shown in Figure 6.D.3.

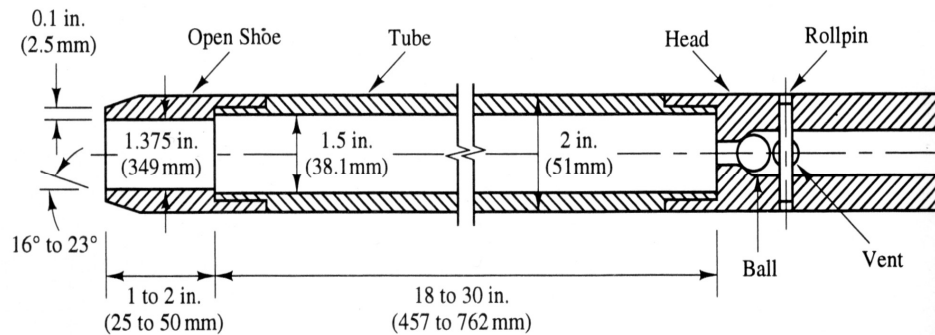


Figure 6.D.2 Schematic diagram of split spoon sampler

It is important to point out that several factors contribute to the variation of the standard penetration number N at a given depth for similar soil profiles. Among these factors are the SPT hammer efficiency, borehole diameter, sampling method, rod length, water table and overburden pressure important. The most two common types of SPT hammers used in the field are the safety hammer and donut hammer. They are usually dropped using a rope with two wraps around a pulley. The hammers are shown in Figure 6.D.4.

Usually SPT is conducted at every 1.5 m or 2 m depth or at the change of stratum. In hard formations, the testing is discontinued if N value is found to be over 100 and it is termed refusal.

D.5.1 Corrections/Standardization of SPT Value for Field Procedures for all Soil Types

On the basis of field observations, it appears reasonable to standardize the field SPT number as a function of the input driving energy and its dissipation around the sampler around the surrounding soil. The variations in testing procedures may be at least partially compensated by converting the measured N to N_{60} as follows.

$$N_{60} = \frac{E_H C_B C_S C_R N}{0.60} \quad (6.D.1)$$

Where,

N_{60} = Corrected SPT N-value for field procedures

E_H = Hammer efficiency (Table 6.D.4)

C_B = Borehole diameter correction (Table 6.D.5)

C_S = Sampler correction (Table 6.D.5)

C_R = Rod length correction (Table 6.D.5)

N = Measured SPT N-value in field

This correction is to be done irrespective of the type of soil encountered.

Table 6.D.4: SPT Hammer Efficiencies

Hammer Type	Hammer Mechanism	Release	Efficiency, E_H
Automatic	Trip		0.70
Donut	Hand dropped		0.60
Donut	Cathead + 2 turns		0.50
Safety	Cathead + 2turns		0.55-0.60
Drop/ Pin	Hand dropped		0.45

Table 6.D.5: Borehole, Sampler and Rod Correction Factors

Factor	Equipment Variables	Correction Factor
Borehole Diameter Factor, C_B	65 mm – 115 mm	1.00
	150 mm	1.05
	200 mm	1.15
Sampling Method Factor, C_S	Standard sampler	1.00
	Sampler without liner	1.20
Rod Length Factor, C_R	3 m – 4 m	0.75
	4 m – 6 m	0.85
	6 m – 10 m	0.95
	> 10 m	1.00

D.5.2 Corrections of SPT Value for Overburden Pressure for all Types of Cohesionless Soils

In cohesionless soils, the overburden pressure affects the penetration resistance. For SPT made at shallow levels, the values are usually too low. At a greater depth, the same soil at the same density index would give higher penetration resistance. It was only as late as in 1957 that Gibbs & Holtz (1957) suggested that corrections should be made for field SPT values for depth.

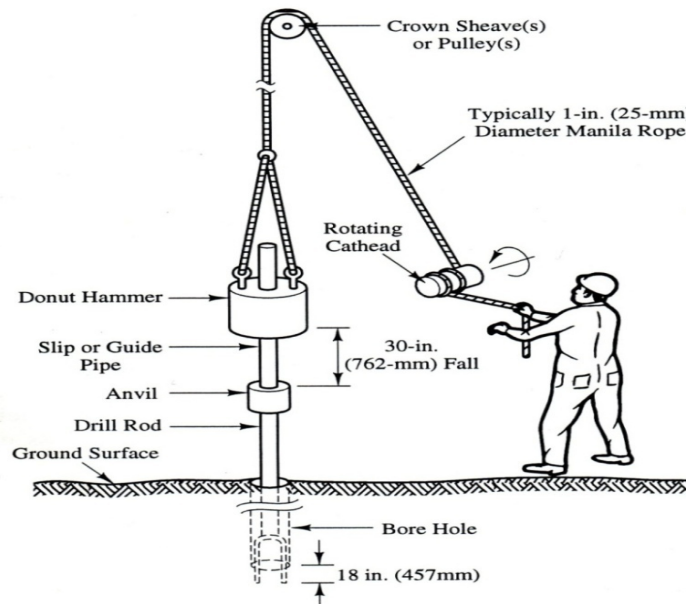


Figure 6.D.3 Demonstrations of standard penetration test

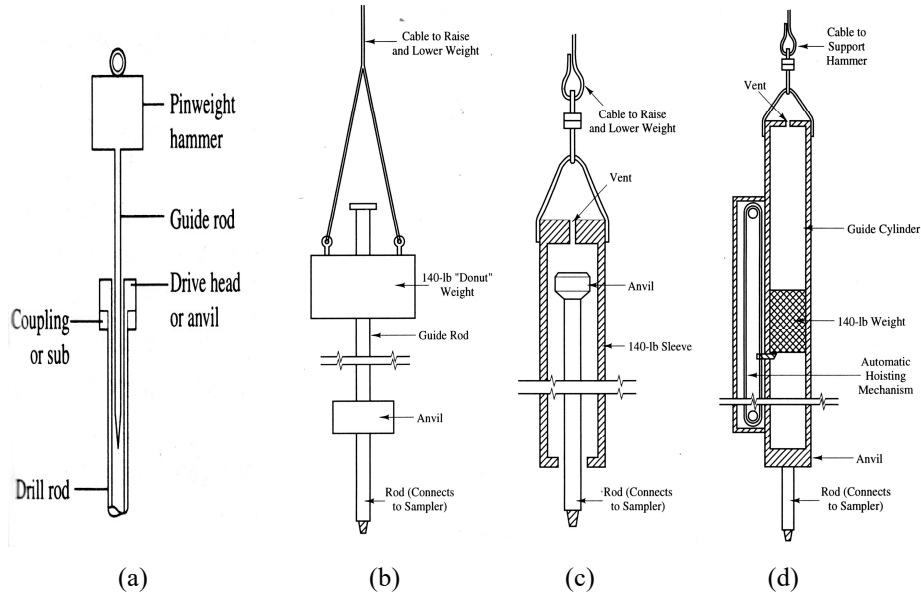


Figure 6.D.4 Configurations of various SPT hammers; (a) Pin (Drop) hammer; (b) Donut hammer; (c) Safety hammer; (d) Automatic hammer

As the correction factor came to be considered only after 1957, all empirical data published before 1957 like those by Terzaghi is for uncorrected values of SPT. Since then a number of investigators have suggested overburden correction. Gibbs & Holtz took standard pressure of 280 kN/m² (corresponding to a depth of 14 m) and duly made overburden correction for other overburdens. Thornburn suggested a standard pressure of 138 kN/m² (corresponding to a depth of 7 m). Finally, Peck et. al. (1974) suggested a standard pressure of 100 kN/m² (Equivalent to 1 tsf or 1 kg/cm² overburden corresponding to a depth of 5 m). As such, all field SPT values are to be corrected by the correction factor given by them as:

$$C_N = 0.77 \log \frac{(2000)}{\sigma'_o} \quad (6.D.2)$$

Where, σ' is the effective overburden pressure. Thus,

$$(N_1)_{60} = C_N \times N_{60} \quad (6.D.3)$$

While using the correction factor given by Equations 6.D.2 and 6.D.3, the corrected N_{60} value is termed as $(N_1)_{60}$ as this correction corresponds to an overburden pressure of 1 ton/ft² or 1 kg/cm². The maximum value of correction factor C_N is 2.

D.5.3 Corrections of SPT Value for Water Table (Dilatancy) in case of Fine Sand and Silty Sand

In addition to corrections of overburden, investigators suggested corrections of SPT-value for water table in the case of fine sand or silt below water table. Apparently, high N-values may be observed especially when observed value is higher than 15 due to dilatancy effect. In such cases, following correction is recommended (Terzaghi and Peck, 1948).

$$(N_1)_{60(CORR)} = 15 + \frac{1}{2}[(N_1)_{60} - 15] \quad (6.D.4)$$

Where, $(N_1)_{60(CORR)}$ is the corrected $(N_1)_{60}$ for water table. For coarse sand this correction is not required. In applying this correction, overburden correction is applied first and then this dilatancy correction is used.

D.5.4 SPT Value and Density Index Relations

Although, the SPT is not considered as a refined and a completely reliable method of investigation, it gives useful information with regard to relative density of cohesionless soil and consistency of cohesive soils. Terzaghi and Peck give the following correlation (Tables 6.D.6 and 6.D.7) between SPT value and other soil parameters.

Several investigators presented average relations between SPT value and peak angle of internal friction, ϕ . The following relations may be noted.

$$\phi^o = 27 + 0.3(N_1)_{60} \quad (6.D.5)$$

$$\phi^o = \sqrt{20(N_1)_{60}} + 15 \quad (6.D.6)$$

The relations are also presented in Figure 6.D.5. The $(N_1)_{60}$ values used in Equations 6.D.5 and 6.D.6 are corrected values of $(N_1)_{60}$

Table 6.D.6: Penetration Resistance and Soil Properties on the Basis of SPT (Cohesionless Soil: Fairly reliable)

N-value	Soil Condition	Relative Density, D_r	Angle of internal friction, ϕ
0 - 4	Very loose	0 – 15%	< 28°
4 - 10	Loose	15 – 35%	28° – 30°
10 - 30	Medium	35 – 65%	30° – 36°
30 - 50	Dense	65 – 85%	36° – 42°
> 50	Very Dense	> 85%	> 42°

Table 6.D.7: Penetration Resistance and Soil Properties on the Basis of SPT (Cohesive Soil)

N- value	Consistency	UC Strength (q_{av}), kN/m ²
0 - 2	Very soft	< 25
2 - 4	Soft	25 - 50
4 - 8	Medium	50 - 100
8 - 15	Stiff	100 - 200
15 - 30	Very stiff	200 - 400
> 30	Hard	> 400

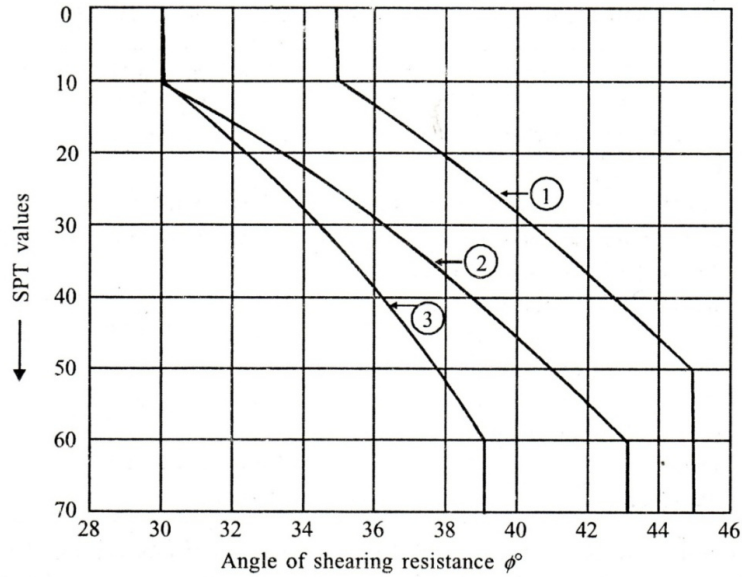


Figure 6.D.5 SPT-φ relations for granular soils; (1) Well graded sand and gravel; (2) Uniform fine sand (Average value); and (3) Silty Sand

The correlation for clays with SPT value is not fully established. Hence, vane shear test is recommended for more reliable information. Even though, SPT values are not considered as a good measure of the strength of clays, it is used extensively as a measure of the consistency of clays. The consistency is then related to its approximate strengths. They may be expressed as:

$$q_u \text{ (in kN per m}^2\text{)} = 12.5 N_{60} \tag{6.D.7}$$

Where, q_{un} is unconfined compressive strength. For highly plastic clays ($PI > 30$) the relation may be:

$$q_{un} \text{ (in kN per m}^2\text{)} = 10 N_{60} \quad (6.D.8)$$

The relations (q_{un} in kg/cm²) are also expressed in Figure 6.D.6.

D.6 Dynamic Cone Penetration Test

The dynamic cone penetration test can be considered only as a variation of SPT. Instead of the spoon sampler used for SPT, a special solid cone of 60° and 50 mm diameter is used as a penetrometer. This probe can be used either in the borehole as an SPT test or without a borehole as a continuous penetration test. The latter may be of the recoverable type or the expendable type. Experience shows that in most soils, the solid cone penetrometer test tends to give a slightly higher value than SPT. These tests are to be used along with SPT tests so that a correlation between the two can be worked out for each site under investigation. It is then used to determine the nature of deposits in other locations at the same site without putting an expensive borehole. As this test is very much cheaper than SPT tests in boreholes, a large number of dynamic cone penetration tests can be made at various locations at nominal cost along with SPT tests.

The blow count for every 100 mm penetration due to a 65 kg weight falling through 750 mm is taken. The total blows for one foot (300 mm) penetration is the dynamic cone value N_{dc} . To save the equipment from damage, driving may be stopped when the number of blows exceeds 35 for 100 mm penetration. Typical cone used dynamic cone penetration test is shown in Figure 6.D.7.

Dynamic cone test can be used with or without bentonite (mud) slurry. But when depth of investigation is more than 6 m, use of bentonite or mud slurry is recommended as otherwise friction on the rods would be tremendous. Data from dynamic cone test is plotted as a curve of penetration resistance, N_{dc} number of blows per 30 cm of penetration, versus depth. The N_c values from dynamic cone penetration tests needed to be corrected for overburden pressure in cohesionless soil like N-values of SPT.

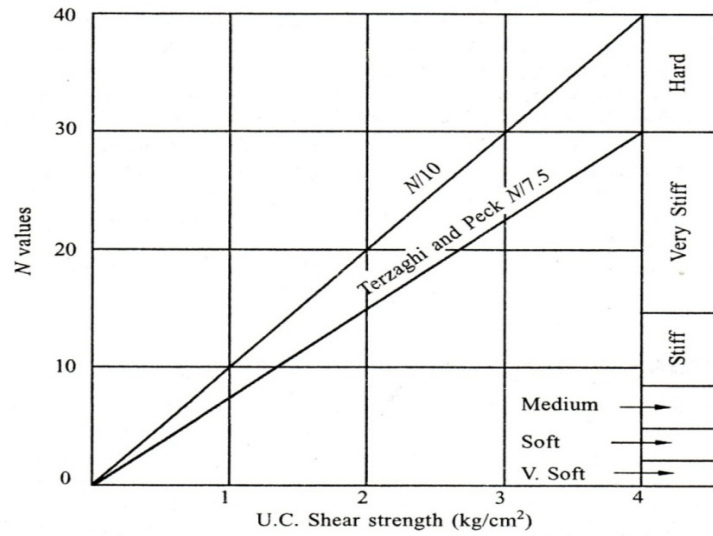


Figure 6.D.6 Relation between SPT and unconfined compressive strength (q_u) of clays

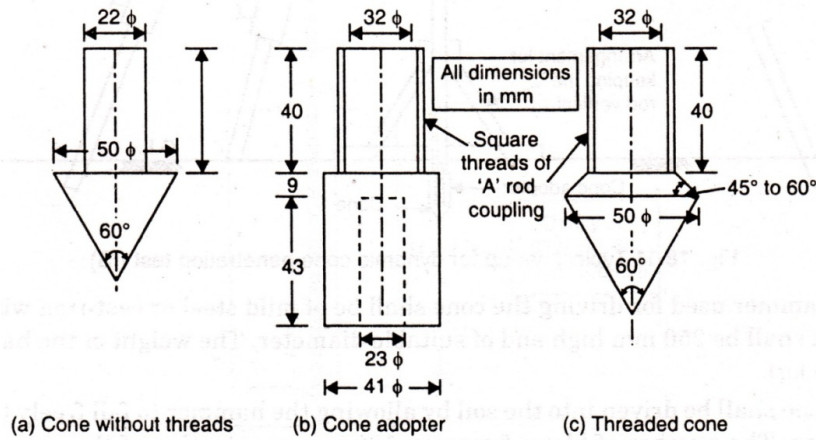


Figure 6.D.7 Typical cone details for dynamic cone penetration test

D.7 Static Cone Penetration Test (Cpt)

The static cone penetration test normally called the Dutch cone penetration test (CPT). It has gained acceptance rapidly in many countries. The method was introduced nearly 50 years ago. The test can be now performed using both mechanical and electrical cones. These test procedures can be found in ASTM D3441 and ASTM D5778 respectively. This test is widely used in Holland, Belgium, Britain, Indonesia, Malaysia, Singapore, West Indies etc. It is finding increasing use in India.

The equipment consists essentially of a steel cone with an apex angle of 60° and overall base diameter of 35.7 mm giving a cross sectional area of 10 cm^2 . The cone is attached to rod which is in turn connected to other rods as necessary. These rods are protected by sleeves known as mantle tubes.

Immediately above the cone a friction jacket, of outside diameter greater than mantle tube, is fitted. The cone and the friction jacket in combination or separately are pushed into the ground by hydraulic cylinder of a machine of capacities presently varying from 20 kN to 100 kN. The necessary reaction is obtained by anchors and sometimes by surcharge loading.

One of the greatest values of the CPT consists of its function as a scale model pile test. Empirical correlations established over many years permit the calculation of pile bearing capacity directly from the CPT results without the use of conventional soil parameters.

The CPT has proved valuable for soil profiling as the soil type can be identified from the combined measurement of end resistance of cone and side friction on a jacket. The test lends itself to the derivation of normal soil properties such as density, friction angle and cohesion. Various theories have been developed for foundation design. The popularity of the CPT can be attributed to the following three important factors:

- (i) General introduction of the electric penetrometer providing more precise measurements, and improvements in the equipment allowing deeper penetration.
- (ii) The need for the penetrometer testing in-situ technique in offshore foundation investigations in view of the difficulties in achieving adequate sample quality in marine environment.
- (iii) The addition of other simultaneous measurements to the standard friction penetrometer such as pore pressure and soil temperature.

D.7.1 The Penetrometer

There are a variety of shapes and sizes of penetrometers being used. The one that is standard in most countries is the cone with an apex angle of 60° and a base area of 10 cm^2 . The sleeve (jacket) has become a standard item on the penetrometer for most applications. On the 10 cm^2 cone penetrometer, the friction sleeve should have an area of 150 cm^2 as per standard practice. The ratio of side friction and bearing resistance, the friction ratio, enables identification of the soil type and provides useful information in particular when no borehole data are available. Even when borings are made, the friction ratio supplies a check on the accuracy of the boring logs.

Two types of penetrometers are used which are based on the method used for measuring cone resistance and friction. They are: (i) The Mechanical Type; (ii) The Electrical Type.

D.7.2 Mechanical Penetrometer

The Begemann Friction Cone Mechanical type penetrometer is shown in Figure 6.D.8. It consists of a 60° cone with a base diameter of 35.6 mm (sectional area 10 cm^2). A sounding rod is screwed to the base. Additional rods of one metre length each are used. These rods are screwed or attached together to bear against each other. The sounding rods move inside mantle tubes. The inside diameter of the mantle tube is just sufficient for the sounding rods to move freely whereas the outside diameter is equal to or less than the base diameter of the cone. All dimensions in Figure 6.D.8 is in mm.

The rigs used for pushing down the penetrometer consist basically of a hydraulic system. The thrust capacity for cone testing on land varies from 20 to 30 kN for hand operated rigs and 100 to 200 kN for mechanically operated rigs as shown in Figure 6.D.9.

Bourden gauges are provided in the driving mechanism for measuring the pressures exerted by the cone and friction jacket either individually or collectively during the operation. The rigs may be operated either on the ground or mounted on heavy duty trucks. In either case, the rig should take the necessary up thrust. For ground based rigs screw anchors are provided to take up the reaction thrust.

D.7.3 Operation of Mechanical Penetrometer

The sequence of operation of the penetrometer shown in Figure 6.D.10 is explained as follows:

Position 1: The cone and friction jacket assembly in a collapsed position.

Position 2: The cone is pushed down by the inner sounding rods to a depth until a collar engages the cone. The pressure gauge records the total force Q_c to the cone. Normally, $a = 40 \text{ mm}$.

Position 3: The sounding rod is pushed further to a depth b . This pushes the friction jacket and the cone assembly together; the force is Q_f . Normally, $b=40 \text{ mm}$.

Position 4: The outside mantle tube is pushed down a distance $(a + b)$ which brings the cone assembly and the friction jacket to position 1. The total movement $= a + b = 80 \text{ mm}$.

The process of operation illustrated is continued until the proposed depth is reached. The cone is pushed at a standard rate of 20 mm per second. The mechanical penetrometer has its advantage as it is simple to operate and the cost of maintenance is low. The quality of the work depends on the skill of the operator. The depth of CPT is measured by recording the length of the sounding rods that have been pushed into the ground.

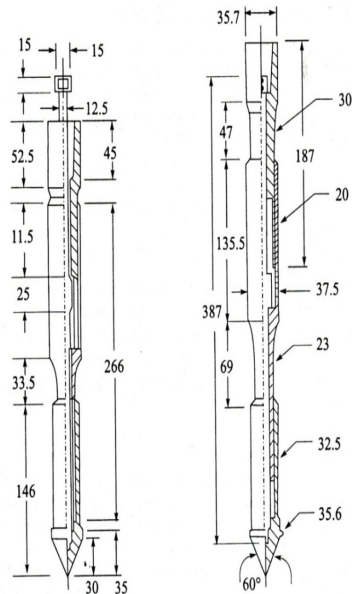


Figure 6.D.8 Friction cone mechanical type penetrometer jacking system (all dimensions are in mm)

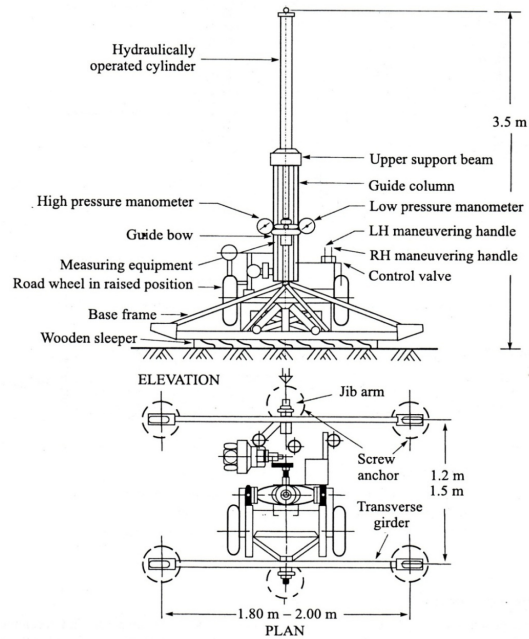


Figure 6.D.9 Assembly of cone penetration rig

D.7.4 The Electric Penetrometer

The electric penetrometer is an improvement over the mechanical one. Mechanical penetrometers operate incrementally whereas the electric penetrometer is advanced continuously.

Figure 6.D.11 shows an electric-static penetrometer with the friction sleeve just above the base of the cone. The sectional area of the cone and the surface area of the friction jacket remain the same as those of a mechanical type. The penetrometer has built in load cells that record separately the cone bearing and side friction. Strain gauges are mostly used for the load cells. The load cells have a normal capacity of 50 to 100 kN for end bearing and 7.5 to 15 kN for side friction, depending on the soils to be penetrated. An electric cable inserted through the push rods (mantle tube) connects the penetrometer with the recording equipment at the surface which produces graphs of resistance versus depth.

The electric penetrometer has many advantages. The repeatability of the cone test is very good. A continuous record of the penetration results reflects better the nature of the soil layers penetrated. However, electronic cone testing requires skilled operators and better maintenance. The electric penetrometer is indispensable for offshore soil investigation.

D.7.5 Operation of Electric Penetrometer

The electric penetrometer is pushed continuously at a standard rate of 20 mm per second. A continuous record of the bearing resistance q_c and frictional resistance f_s against depth is produced in the form of a graph at the surface in the recording unit.

D.7.6 Piezocone

A piezometer element included in the cone penetrometer is called a piezocone, Figure 6.D.12. There is now a growing use of the piezocone for measuring pore pressures at the tips of the cone. The porous element is mounted normally midway along the cone tip allowing pore water to enter the tip. An electric pressure transducer measures the pore pressure during the operation of the CPT. The pore pressure record provides a much more sensitive means to detect thin soil layers. This could be very important in determining consolidation rates in a clay soil within the sand seams.

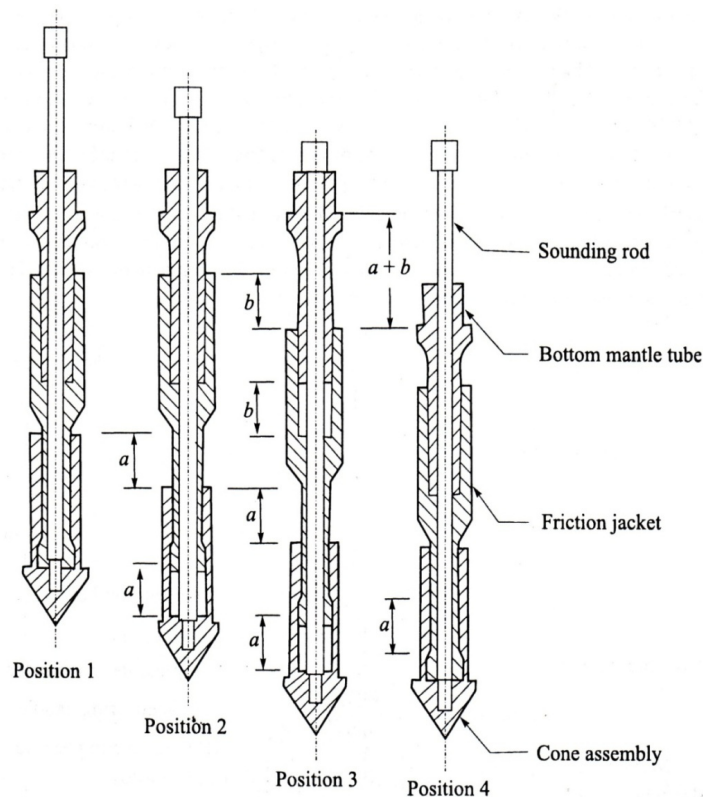


Figure 6.D.10 Steps in cone penetration testing

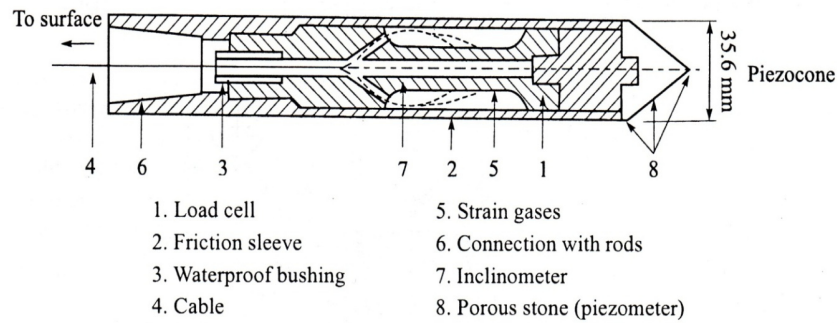


Figure 6.D.11 Electrical static cone penetrometer

D.7.7 Temperature Cone

The temperature of a soil is required at certain localities to provide information about environmental changes. The temperature gradient with depth may offer possibilities to calculate the heat conductivity of the soil. Measurement of the temperature during CPT is possible by incorporating a temperature sensor in the electric penetrometer. Temperature measurements have been made in permafrost, under blast furnaces, beneath undercooled tanks, along marine pipe lines, etc.

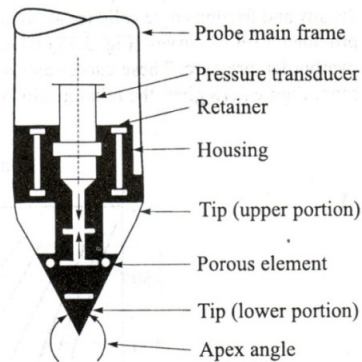


Figure 6.D.12 Details of piezocone

D.7.8 Effect of Rate of Penetration

Several studies have been made to determine the effect of the rate of penetration on cone bearing and side friction. Although the values tend to decrease for slower rates, the general conclusion is that the influence is insignificant for speeds between 10 and 30 mm per second. The standard rate of penetration has been generally accepted as 20 mm per second.

D.7.9 Cone Resistance q_c and Local Side Friction f_c

Cone penetration resistance q_c is obtained by dividing the total force Q_c acting on the cone by the base area A_c .

$$q_c = \frac{Q_c}{A_c} \quad (6.D.9)$$

In the same way, the local side friction f_c is:

$$f_c = \frac{Q_f}{A_f} \quad (6.D.10)$$

Where, $Q_f = Q_r - Q_c =$ force required for pushing the friction jacket

$Q_t =$ total force required to push the cone and friction jacket together in the case of a mechanical penetrometer,

$A_f =$ surface area of the friction jacket.

D.7.10 Friction Ratio, R_f

Friction ratio, R_f is expressed as:

$$R_f = \frac{f_c}{q_c} \quad (6.D.11)$$

Where, f_c and q_c are measured at the same depth. R_f is expressed as a percentage.

Friction ratio is an important parameter for classifying soil.

D.7.11 Relationship between q_c , Relative Density D_r and Friction Angle ϕ for Sand

Research carried out by many indicates that a unique relationship between cone resistance, relative density and friction angle valid for all sands does not exist. Robertson and Campanella (1983a) have provided a set of curves (Figure 6.D.13) which may be used to estimate D_r based on q_c and effective overburden pressure. These curves are supposed to be applicable for normally consolidated clean sand. Figure 6.D.14 gives the relationship between q_c and ϕ (Robertson and Campanella, 1983b).

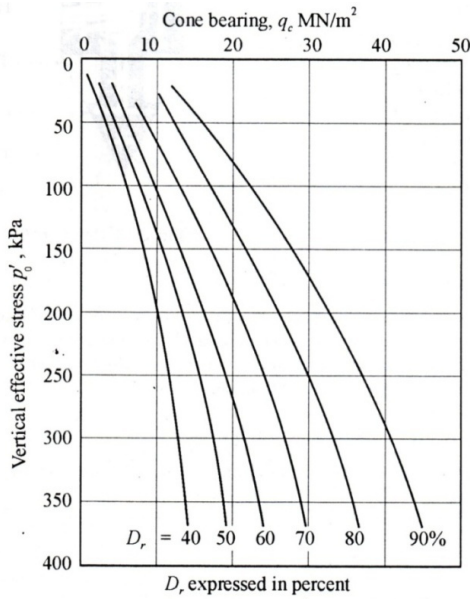


Figure 6.D.13 Relationship between relative density, D_r and cone resistance, q_c for quartz sand (Robertson and Campanella, 1983a)

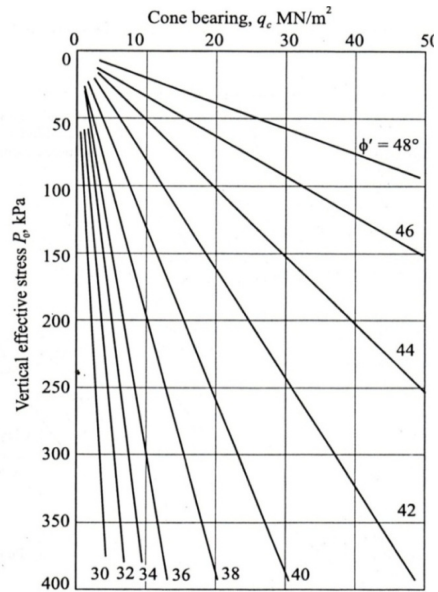


Figure 6.D.14 Relationship between cone resistance, q_c and relative density, D_r for quartz sand (Robertson and Campanella, 1983b)

D.7.12 Relationship between q_c and Undrained Shear Strength, c_u of Clay Soil

The cone penetration resistance q_c and c_u may be related as:

$$q_c = N_k c_u + p_o \text{ or, } c_u = \frac{q_c - p_o}{N_k} \tag{6.D.12}$$

Where, N_k = cone factor,

$p_o = \gamma Z$ = overburden pressure.

Lune and Kelven (1981), investigated the value of the cone factor N_k for both normally consolidated and overconsolidated clays. The values of N_k as obtained are given below in Table 6.D.7.

Table 6.D.7: Soil Type and q_c Value

Type of Clay	Cone Factor, N_k
Normally Consolidated	10 to 19
Over Consolidated:	
At shallow depth	15 to 20
At deep depth	12 to 18

Possibly a value of 20 for N_k for both types of clay may be satisfactory. Sanglerat (1972) recommends the same value for all cases where an overburden correction is of negligible value.

D.7.13 Soil Classification based on CPT Results

One of the basic uses of CPT is to identify and classify soils. A CPT-Soil Behaviour Type Prediction System has been developed by Douglas and Olsen (1981) using an electric and friction cone penetrometer. The classification is based on the friction ratio f_c/q_c . The ratio f_c/q_c varies greatly depending on whether it applies to clays or sands. Their findings have been confirmed by hundreds of tests.

For clay soils, it has been found that the friction ratio decreases with increasing liquidity index, I_L . Therefore, the friction ratio is an indicator of the soil type penetrated. It permits approximate identification of soil type though no samples are recovered.

Douglas (1984), presented a simplified classification chart shown in Figure 6.D.15. His chart uses cone resistance normalized (q_{cn}) for overburden pressure using the equation:

$$q_{cn} = q_c (1 - 1.25 p'_o) \quad 6.D.13$$

Where, p'_o = effective overburden pressure in tsf, and q_c = cone resistance in tsf.

The CPT data provides a repeatable index of the aggregate behavior of in-situ soil. The CPT classification method provides a better picture of overall subsurface conditions than is available with most other methods of exploration. A typical sounding log is given in Figure 6.D.16.

The friction ratio R_f varies greatly with the type of soil. The variation of R_f for the various types of soils is generally of the order given in Table 6.D.8.

Table 6.D.8: Soil Classification Based on Friction Ratio

Friction Ratio, R_f (%)	Type of Soil
0.0 - 0.5	Loose gravel fill
0.5 - 2.0	Sands and gravels
2.0 - 5.0	Clay sand mixtures and silts
> 5.0	Clays, peats etc.

Meyerhof (1965), presented comparative data between SPT and CPT. For fine or silty medium loose to medium dense sands, he presents the correlation as:

$$q_c = 0.4N \quad (\text{in MN/m}^2) \quad (6.D.14)$$

Meyerhof's findings are as given in Table 6.D.9. The lowest values of the angle of ϕ given in Table 6.D.9 are conservative estimates for uniform, clean sand and they should be reduced by at least 5° for clayey sand. These values, as well as the upper values of ϕ that apply to well graded sand, may be increased by 5° for gravelly sand.

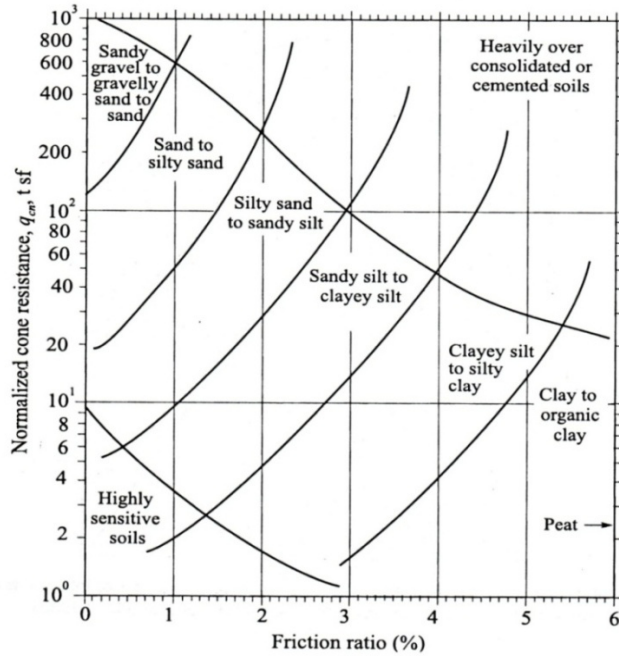


Figure 6.D.15 A simplified classification chart (after Douglas, 1984)

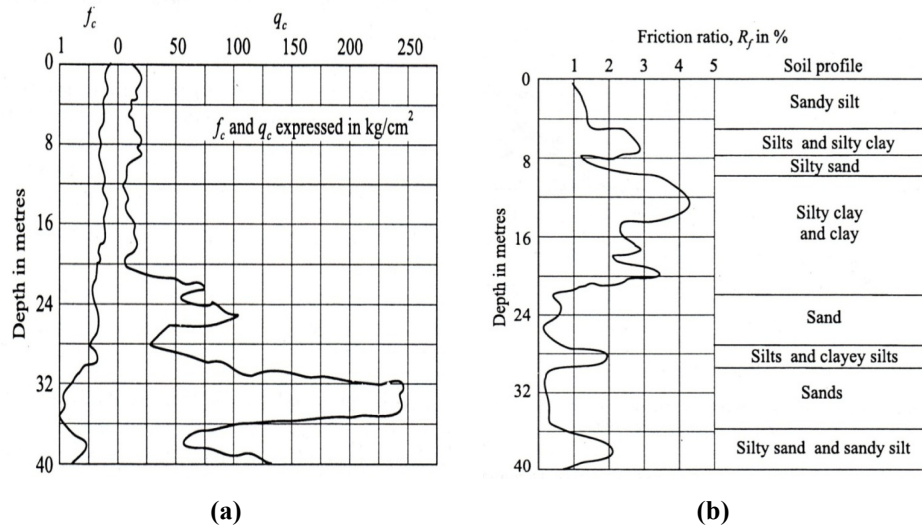


Figure 6.D.16 Typical Sounding Log; (a) Cone resistance with depth; (b) Friction ratio with depth

Table 6.D.9: Soil Classification Based on Friction Ratio

State of Sand	D_r	$(N_1)_{60}$	q_c (MPa)	ϕ°
Very loose	< 0.2	< 4	< 2.0	< 30
Loose	0.2-0.4	4-10	2-4	30-35
Medium dense	0.4-0.6	10-30	4-12	35-40
Dense	0.6-0.8	30-50	12-20	40-45
Very dense	0.8-1.0	> 50	> 20	> 45

D.7.14 Correlation between SPT and CPT

Figure D.17 shows correlations presented by Robertson and Campanella (1983a), and Kuhawy and Mayne (1990) between the ratio of q_c/N and mean grain size, D_{50} . It can be seen from the Figure 6.D.17 that the ratio varies from 1 at $D_{50}=0.001$ mm to a maximum value of 8 at $D_{50}=1.0$ mm. The soil type also varies from clay to sand.

It is clear from the above discussions that the value of $n = q_c/N$ is not a constant for any particular soil. Designers must use their own judgement while selecting a value for n for a particular type of soil.

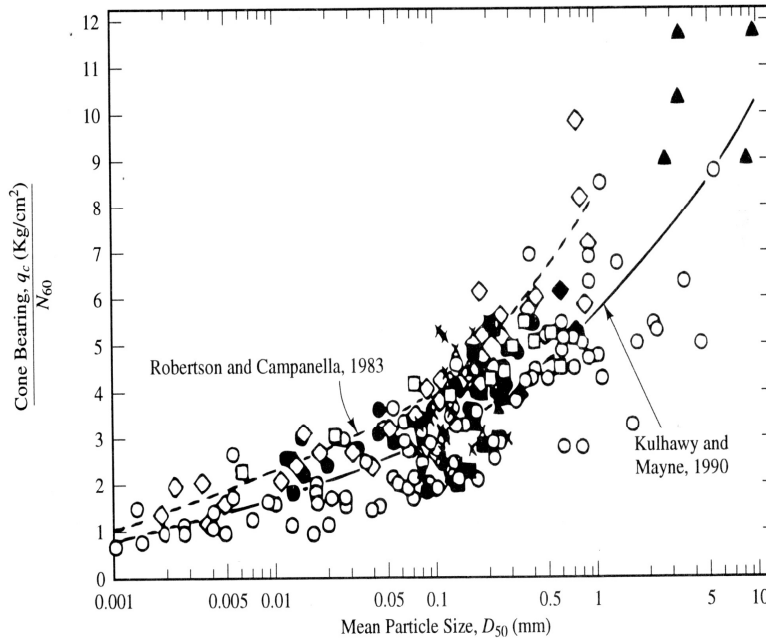


Figure 6.D.17 Relation between q_c/N and mean grain size D_{50}

D.8 Geophysical Methods of Exploration

Several types of geophysical exploration techniques permit a rapid evaluation of subsoil characteristics. These methods also allow rapid coverage of large areas and are less expensive than conventional exploration by drilling. However, in many cases, definitive interpretation of the results is difficult. For that reason, such techniques should be used for preliminary work only. Three types of geophysical exploration are common: the seismic refraction survey, cross-hole seismic survey and electrical resistivity survey.

D.8.1 Seismic Refraction Survey

This method is useful in obtaining preliminary information about the thickness of the layering of various soils and the depth to rock or hard soil at a site. The test method is described in ASTM D5777. Refraction surveys are conducted by impacting the surface, such as point A in Figure 6.D.18a, and observing the first arrival of the disturbance (stress waves) at several other points (e.g. B, C, D, ...). The impact can be created by a hammer blow or by a small explosive charge. The first arrival of disturbance waves at various points can be recorded by geophones.

The impact on the ground surface creates two types of stress wave: 'P' waves (or plane waves) and S waves (or shear waves). P waves travel faster than S waves; hence the first arrival of disturbance waves will be related to the velocities of the 'P' waves in various layers. The velocity of P waves in a medium is:

$$v = \frac{\sqrt{E_s(1-\mu)}}{\left(\frac{\gamma}{g}\right)(1-\mu_s)(1+\mu_s)} \quad (6.D.15)$$

Where, E_s = modulus of elasticity of the medium

γ = unit weight of the medium

g = acceleration due to gravity

μ_s = Poisson's ratio of soil

To determine the velocity v of P waves in various layers and thicknesses of those layers, the following procedure is used.

The first arrival times $t_1, t_2, t_3 \dots$ at various distances $x_1, x_2, x_3 \dots$ from the point of impact is obtained. A graph of time t against distance x is plotted, as shown in Figure 6.D.18b. The slopes of the line ab, bc, cd, are determined.

$$\text{Slope of } ab = \frac{1}{v_1}$$

$$\text{Slope of } bc = \frac{1}{v_2}$$

$$\text{Slope of } cd = \frac{1}{v_3}$$

Here v_1, v_2, v_3, \dots are the P-wave velocities in layers I, II, III, ... respectively (Figure 6.D.18a). The thickness of the top layer is determined as:

$$Z_1 = \frac{x_c}{2} \sqrt{\frac{v_2 - v_1}{v_2 + v_1}} \quad (6.D.16)$$

The value of x_c can be obtained from Figure 6.D.17b. The thickness of the second layer can be determined from

$$z_2 = \frac{1}{2} \left[T_{i2} - 2Z_1 \frac{\sqrt{v_3^2 - v_1^2}}{v_3 v_1} \right] \frac{v_3 v_2}{\sqrt{v_3^2 - v_2^2}} \quad (6.D.17)$$

Where, T_{i2} is the time intercept of the line cd (Figure 6.D.18a). Velocities of P-waves in various layers indicate the types of soil or rock that are present below the ground surface. They are listed in Table 6.D.10.

In analyzing the results of a refraction survey, two limitations need to be kept in mind.

- (i) The basic equations for the survey that is, Equations 6.D.16 and 6.D.17 are based on the assumption that the P-wave velocity $v_1 < v_2 < v_3 \dots \dots$
- (ii) When a soil is saturated below the water table, the P-wave velocity may be deceptive. P-wave can travel with a velocity of about 1500 m/sec through water. For dry, loose soils the velocity may be well below. If the presence of groundwater has not been detected, the P-wave velocity may be erroneously interpreted to indicate a stronger material (sandstone). In general, geophysical interpretations should always be verified by the results obtained from borings.

D.8.2 Cross Hole Survey

The test method can be found in ASTM D4428-07. The velocity of shear waves created as a result of an impact to a given layer of soil can be effectively determined by the cross-hole seismic survey. The principle of this technique is illustrated in Figure 6.D.19. Two holes are drilled into the ground at a distance L apart. A vertical impulse is created at the bottom of one borehole by means of an impulse rod. The shear waves thus generated are recorded by means of a vertically sensitive transducer. The velocity of shear waves can be calculated as:

$$v_s = \frac{L}{t} \quad (6.D.18a)$$

Where, t is the travel time of the wave. The shear modulus G_s of the soil at the depth at which the test is done can be determined from the relation:

$$v_s = \sqrt{\frac{G_s}{(\gamma/g)}} \text{ or } G_s = \frac{v_s^2 \gamma}{g} \quad (6.D.18b)$$

Where, v_s = velocity of shear waves
 γ = unit weight of soil
 g = acceleration due to gravity

Shear modulus is useful in the design of foundations to support vibrating machinery and the like.

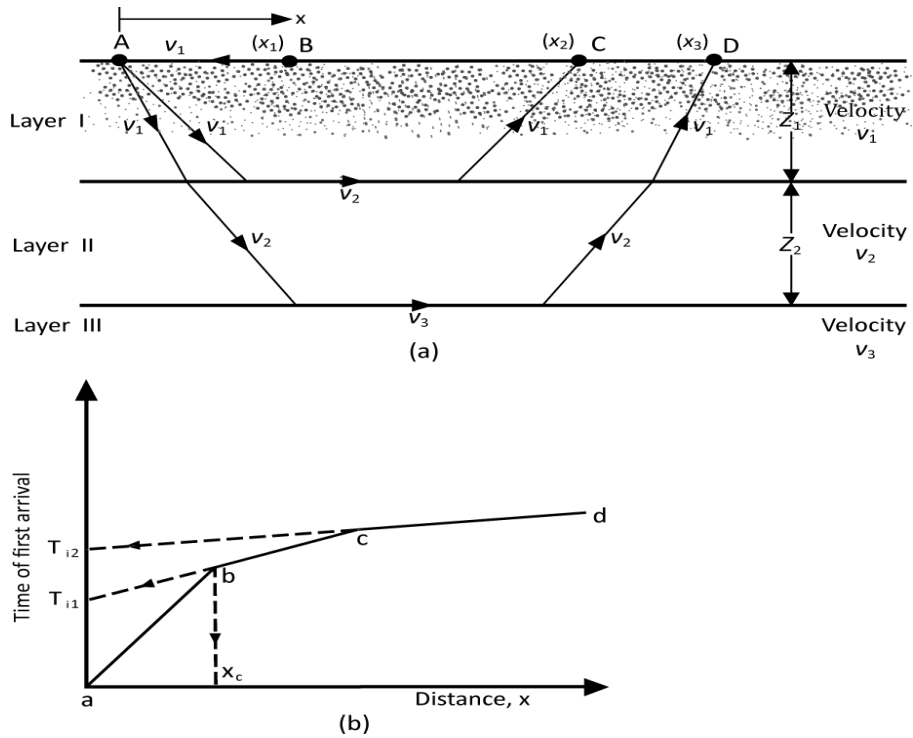


Figure 6.D.18 Seismic refraction survey

Table 6.D.10 : Range of P-Wave Velocity in Various Soils and Rocks

Type of soil or rock	P-wave velocity	
	M/sec	Ft/sec
Soil:		
Sand, dry silt, and fine grained top soil	200—1000	650—3300
Alluvium	500—2000	1650—6600
Compacted clays, clayey gravel and dense clayey sand	1000—2500	3300—8200
Loess	250—750	800—2450
Rock :		
Slate and shale	2500—5000	8200—16400
Sandstone	1500—5000	4900—16400
Granite	4000—6000	13100—19700
Sound limestone	5000—10000	16400—32800

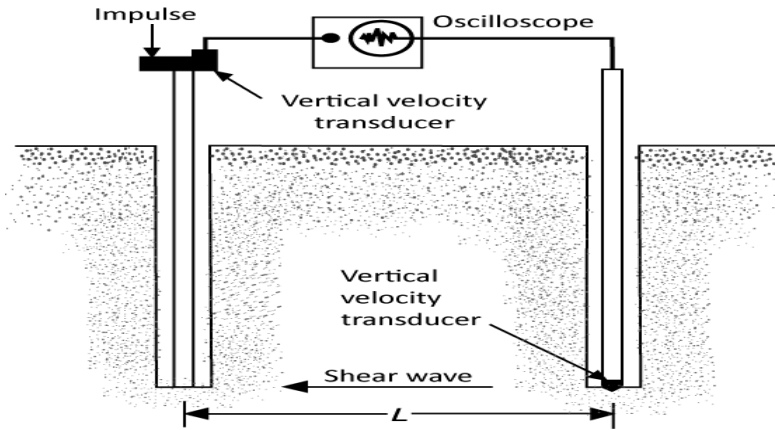


Figure 6.D.19 Cross-hole method of seismic survey

D.8.3 Resistivity Survey

The electrical resistivity of any conducting material having length L , cross sectional area A and electrical resistance R can be defined as :

$$\rho = \frac{RA}{L} \quad (6.D.19)$$

The unit of resistivity is ohm-metre. The resistivity of various soils depends primarily on their moisture content and also on the concentration of dissolve ions in them. The range of resistivity of various soils and rocks are given in Table 6.D.11.

The most common procedure of measuring the electrical resistivity of a soil profile makes use of four electrodes driven into the ground spaced equally along a straight line. The procedure is generally known as Wenner method. The two outside electrodes are used to send an electrical current I (using dc current) into the ground. The current is typically in the range of 50-100 milliamperes. The voltage drop V is measured between the two inside electrodes. The test arrangements are shown in Figure 6.D.20a. If the soil profile is homogeneous, its electrical resistivity is given by :

$$\rho = \frac{2\pi d v}{I} \quad (6.D.20)$$

In most cases, the soil profile may consists of various layers with different resistivities and Eq. 6.D.20 will yield the apparent resistivity. To obtain actual resistivity of various layers and their thicknesses, an empirical method may be used. It involves conducting test at various electrode spacing. Thus, the sum of the apparent resistivities $\Sigma\rho$ obtained is plotted against the spacing d as shown in Figure 6.D.20b. The plot thus obtained has relatively straight segments, the slopes of which give the resistivity of individual layers. The determination of thickness of layers is illustrated in Figure 6.D.20b. The resistivity survey is particularly useful in locating gravel deposits within a fine grained soil.

Table 6.D.11 Electrical Resistivity of Various Types of Soils

Soil type	Resistivity (ohm-m)
Sand	500-1500
Clays, saturated silts	0-100
Clayey sand	200-500
Gravel	1500-4000
Weathered rock	1500-2500
Sound rock	> 5000

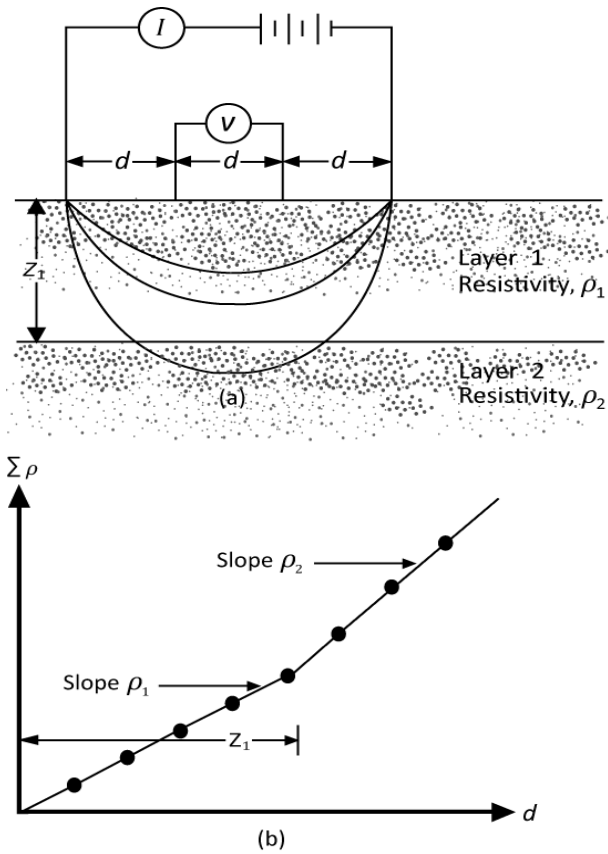


Figure 6.D.20 Electrical resistivity survey; (a) Wenner method of placing electrode; (b) Empirical method of determining resistivity and thickness of soil layer.

PART VI
Appendix E

Recommended Criteria for Identification and Classification of Expansive Soil

The following criteria may be adopted to identify and classify expansive soils:

- (1) Based on the values of plasticity index and shrinkage limit, United States Bureau of Reclamation (USBR) suggests the following classification criteria for expansive soil:

Plasticity Index	Shrinkage Limit	Degree of Expansion
>35	<10	Very High
25-41	6-12	High
15-28	8-18	Medium
<18	>13	Low

- (2) On the basis of previous data for linear shrinkage of Bangladesh soils, criteria for the degree of expansion proposed by Hossain (1983) is as follows:

Linear Shrinkage (%)	Degree of Expansion
> 14	High
10-14	Medium
0-10	Low

- (3) On the basis of the values of free swell, Indian standard (IS: 1948, 1970) recommends criteria of expansion is as follows:

Free Swell (%)	Degree of Expansion	Danger of Severity
<50	Low	Non-critical
50-100	Medium	Marginal
100-200	High	Critical
>200	Very High	Severe

- (4) Based on the value of free swell index, Indian Standard (IS: 2911, Part III, 1980) suggests the following criteria for the degree of expansion of soils:

Free Swell Index (%)	Degree of Expansion	Danger of Severity
<20	Low	Non-critical
20 to 35	Medium	Marginal
35 to 50	High	Critical
>50	Very high	Severe

- (5) Based on the values of liquid limit, plasticity index and shrinkage limit, Indian Standard (IS: 2911, Part 3, 1980) suggests the following criteria for the degree of expansiveness of soils:

Liquid Limit (%)	Plasticity Index	Degree of Expansion	Danger of Severity
20-35	<12	Low	Non-critical
35-50	12-23	Medium	Marginal
50-70	23-32	High	Critical
>70	>32	Very high	Severe

- (6) Based on the values of swelling potential, Seed et al. (1962) proposed the following four categories of expansion characteristics:

Swelling Potential (%)	Degree of Expansion
0-1.5	Low
1.5-5	Medium
5-25	High
> 25	Very high

- (7) Based on the values of swelling pressure, Chen (1965) proposed the following criteria for degree of expansion:

Swelling Pressure kg/cm²	Degree of Expansion
0-1.5	Low
1.5-2.5	Medium
2.5-9.8	High
>9.8	Very high

- (8) Based on the values of volume change from air dry to saturated condition, Seed et al. (1962) proposed the following four categories of expansion characteristics:

Volume Change from Air Dry to Saturated Condition (%)	Degree of Expansion
0 – 10	Low
10 – 20	Medium
20 – 30	High
> 30	Very high

- (9) Look (2007) reports that the plasticity index by itself can be misleading, as the test is carried out on the percent passing the 425 micron sieve, i.e. any sizes greater than 425 μm is discarded. There have been cases when a predominantly “rocky/granular” site has a high PI test results with over 75 percent of the material discarded. The weighted plasticity index (WPI) considers the percent of material used in the test, where $WPI = PI \times \% \text{ passing the } 425 \text{ micron sieve}$. Degree of expansion with weighted plasticity index is presented as under.

Weighted Plasticity Index (%)	Degree of Expansion
< 1200	Very Low
1200 – 2200	Low
2200 – 3200	Moderate
3200 – 5000	High
> 5000	Very high

PART VI
Appendix F
Construction of Pile Foundation

F.1 Introduction

The pile driving process needs to fulfill assumptions and goals of the design engineer just as much as the design process has to foresee the conception and installation of the pile at the site. This is only possible through the selection of the right driving equipment especially hammer with proper assembly mounted on the most suitable leader, operated according to the specified practices of installation that consists of a series of principle and subsidiary procedures.

There are three methods of driving piles: jacking, vibratory driving, and driving. The first two, jacking and vibratory driving are comparatively rare. The reaction needed to push a pile into the ground is equal to the limit pile capacity, which can be a very large load. Until recently, this made jacking suitable only for small piles; large, heavy rigs are now available that can jack normal size piles for onshore applications.

Vibratory driving is only suitable for loose sands, particularly if saturated, because liquefaction of the sand results from the vibration, making it easy to drive the pile into the ground. Vibratory driving is routinely used to drive sheet piles and less frequently used to install relatively small steel H-piles.

The most common method of installing displacement piles is by driving the piles into the ground by blows of an impact hammer. Piles installed in this manner are referred to as driven piles. In order to understand this method of installation, we need to examine first the equipment that is required. A brief description of the driving equipment and procedures as given by Salgado (2011) are presented as under.

F.2 Piling Driving Equipment

Pile driving equipment are broadly classified into three groups; the leader for positioning the pile for driving, the hammer for delivering energy for driving and the driving system components for better and safe distribution of energy on the top of the piles. Hammers are used to install the driven piles. The leader, the pile and the hammer are often carried by a special crawler rig or crane.

F.3 Installation of Driven Piles

Driven piles are installed by the kinetic energy developed through the

- (a) Ramming action of piling hammer which can be
- Drop Hammers
 - Single-Acting Air/Steam Hammers
 - Double-Acting Air/Steam Hammers
 - Differential-Acting Air/Steam Hammers
 - Hydraulic Hammers
 - Diesel Hammers (Single acting & Double acting)
- (b) Vibration and weight of vibro-hammers which can be
- Electric Motor Vibrohammers
 - Hydraulic Vibrohammers
 - Sonic Resonance Vibrohammers

As such, there are three methods of installing displacement piles: jacking, vibratory driving, and driving. The first two, jacking and vibratory driving are comparatively rare. In jacking, the reaction needed to push a pile into the ground is equal to the limit pile capacity, which can be a very large load. Until recently, this made jacking suitable only for small piles. However, large, heavy rigs are now available that can jack normal size piles for onshore applications. Vibratory driving is only suitable for loose sands, particularly if saturated, because liquefaction of the sand results from the vibration, making it easy to drive the pile into the ground. Vibratory driving is routinely used to drive sheet piles and less frequently used to install relatively small steel H-piles.

The most common method of installing displacement piles is by driving the piles into the ground by blows of an impact hammer. Piles installed in this manner are referred to as driven piles. In order to understand this method of installation, we need to examine first the equipment that is required and described as under.

Sometimes, to penetrate the pile through a compact ground layer or a rock layer, predrilling is used. By predrilling, it is ensured that driven piles reach their designed minimum tip depths, and also, their risk of being tip or head damaged due to increased hammering impact loads are avoided. Another benefit of predrilling is increased driving speeds and much lower ratios of early refusal.

In addition, water jetting is used to penetrate piles through dense granular layers and to guarantee their penetration to minimum penetration depths without getting damaged. Both predrilling and water jetting need to be stopped several meters (about 1.5 – 3 m) before the final penetration point and driving refusal must be obtained in the undisturbed soil.

F.4 Pile Driving Leads

Pile driving leads or leaders are steel frames used to correctly position the pile for driving and to keep the pile head and hammer aligned concentrically during driving. Leads, with length exceeding that of the pile to be driven by 5-7 m, are attached to a crane in one of the two ways shown in Figure 6.F.1. Fixed leads are connected near the top with a horizontal hinge at the tip of the boom. A hydraulically operated horizontal brace allows the operator to adjust the inclination of the lead to install battered piles and to adjust verticality. Hanging leads are suspended from the crane boom by a cable. Stabbing points at the base of the lead allow the operator to adjust position and inclination, but it is more difficult to position the pile with hanging leads than with fixed leads. If hanging leads are to be used to drive piles that require a high degree of positioning accuracy, a suitable template should be provided to maintain the leads in a steady or fixed position. Construction tolerances on positioning depend to some extent on the diameter of the piles and whether they are isolated piles or are part of a group. For group piles, pile location may be off by as much as 75 mm and deviation from vertical as large as 1 in 25 may be acceptable.

Leads that are not properly restrained may cause pile damage, particularly to concrete piles. When driving long slender piles, the use of intermediate pile supports in the leads may be necessary to prevent pile damage that may be caused by long unbraced pile lengths. Leads are not absolutely necessary for every pile driving operation, but they are normally used to maintain concentric alignment of the pile and hammer and to obtain the required accuracy of pile position and alignment while driving the pile, especially for battered piles. Even if leads are not used, it is highly advisable to use a template to maintain the pile at the right location throughout driving.

F.5 Piling Hammers

Pile driving hammers are devices used to deliver blows to the head of a pile in order to drive it into the ground. The type of hammers can be highly varied. Figure 6.F.2 taken from Hannigan et al (1998) gives a classification of Piling Hammer Types. Simple drop and steam hammers are still being used but single, differential or double acting diesel, and hydraulic hammers are more common. Also, vibrating and sonic hammers are being used more and more often due to environmental or urban impact factors.

Pile hammers vary in the rate at which blows are delivered, the maximum amount of energy delivered in any one single blow, and the duration of the blow. To a large extent, these performance parameters reflect the mechanism of operation of the hammer. There are basically four types of hammers: gravity or drop hammers, single-acting hammers, double-acting hammers, and differential hammers.

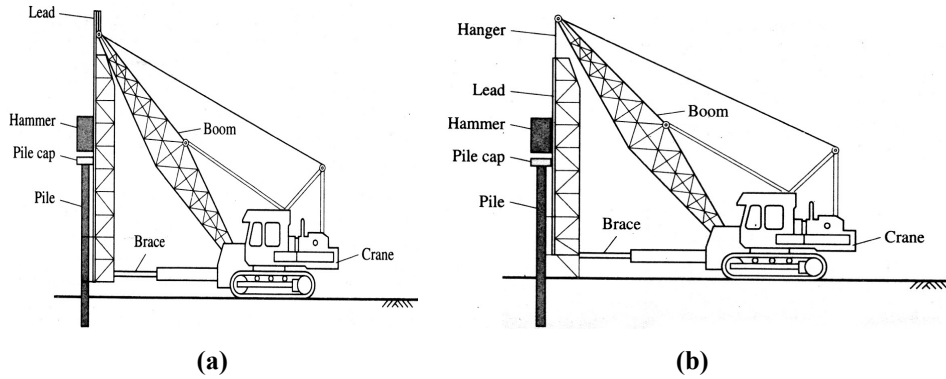


Figure 6.F.1 Crane mounted leads; (a) Fixed and (b) Hanging

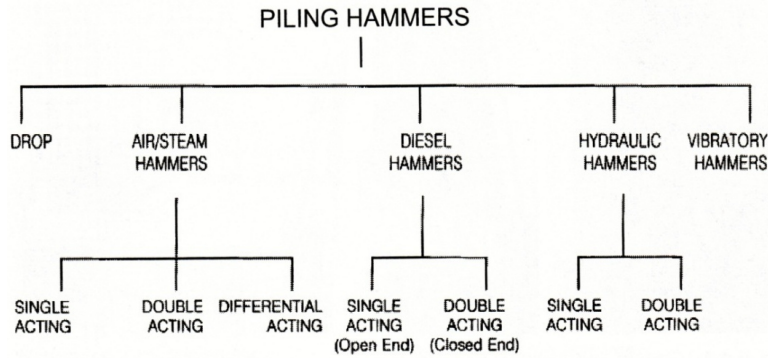


Figure 6.F.2 Pile driving hammer classification (Hannigan et al, 1998)

Table 6.F.1 summarizes the main features of each type of pile driving hammer. Drop hammers are the simplest, relying solely on gravity for delivering the blows to the pile head. A drop hammer is usually made of a single block or a system of steel blocks, which may be removed or added as needed. Drop hammer weights are typically in the range of 10-50 kN (1-5 tons). Because the weight of the hammer is usually fixed during the driving of any given pile, the only variable available to the operator for adjusting the energy delivered by hammer blows is the drop height. There is an implied danger when driving concrete piles through hard, strong soil (under so called hard driving conditions). The operator may drop the hammer from too large a height, generate excessive large stresses in the pile, and damage it.

In single acting hammers, the ram is connected to a piston located within a cylinder [Figure 6.F.3(a)]. The piston is lifted by either steam or compressed air (in what is called the upstroke) and then allowed to fall by the action of gravity (the downstroke). When it does, the ram impacts the head of the pile, driving it some distance into the ground. The weight of a single acting hammer (in the 20 to 150 kN range) is much larger than that of a drop hammer, but the fall height (stroke) is much smaller (up to 1.5 m, typically).

In a double-acting hammer [Figure 6.F.3(b)], either steam or compressed air is used to increase the pressure on the piston, both on its way up and on its way down, so that the ram impacts the pile with greater force and higher velocity and does so more times per minute. This is possible because these hammers are closed at the top. The stroke is typically less than that for the single acting hammer, resulting in higher production rate. The stroke cannot be controlled visually because the hammer is closed. The differential hammer is much like the double-acting hammer, but it relies on the different areas of the upper and lower parts of the piston to generate the repeating up and down strokes.

Table 6.F.1: General Characteristics of Different Types of Piling Hammers

Hammer	Ram weight (kN)	Stroke (m)	Max. strike rate (bpm)	Conditions under which use indicated	Caution
Drop	10-50 (½ to 2 times pile weight)	Wide range	5-10	Noise restrictions	Possible damage during hard driving of concrete piles
Single acting	20-150	< 1.5	40-60		
Double acting / Differential	0.5-180		90-300	Underwater operations; Sheet pile driving	
Diesel	10-150		40-100	All types of piles (with diameter up to 2.2m) in most soil conditions	Soft clays (where combustion may not occur)

Hydraulic hammers are moved by oil pressure and can be of single or double acting varieties. Their principle of operation Intake is essentially the same as that of other single- and double-acting hammers. Diesel hammers, such as the one shown in Figure

6.F.3(d), also come in both the single and double acting varieties, but they differ from other hammers in one important aspect. In single acting hammers, extra "zip" is added to the blow by combustion of fuel injected before the down stroke is completed. In a double acting hammer, a bounce chamber is present in the upper part of the hammer, providing quicker and stronger rebound from the upstroke. These hammers tend to be smaller and lighter than double acting hammer. Other hammers, as the extra energy and blow duration obtained from the fuel combustion makes them very efficient.

The amount of fuel injection into the chamber of diesel hammers can be controlled, allowing adjustment for lighter or harder driving conditions. However, in soils alternating loose/soft layers with extremely hard layers, the bounce of the ram will vary from low to high, which may be damaging to concrete piles. Diesel hammers may be attached directly to the pile head, not strictly requiring the use of leads for their operation.

F.6 Driving System Components

The components of a driving system are the hammer (Impact block) itself and a number of additional components that may or may not be present, as shown in Figure 6.F.4. Each of these components is referred to by various names, the most common being:

- (i) Anvil (striker plate)
- (ii) Cap block or hammer cushion
- (iii) Driving head (helmet, cap, anvil block)
- (iv) Follower
- (v) Pile cushion (used for driving precast concrete piles)

All of these elements, except the follower, aim to diffuse some of the energy from the hammer blow in order to avoid damage to the pile or any of the driving system components. The driving head goes on top of the pile; it is shaped in a way that allows it to slide along the leads, forcing the alignment of the pile and the hammer. The follower is an extension used when a pile needs to be driven to a level below the level of operation of the rig, such as when the heads of the piles for a bridge, for example, will be located under water. The pile cushion is used to further diffuse and better distribute the energy on top of concrete piles, which are more susceptible to damage during driving.

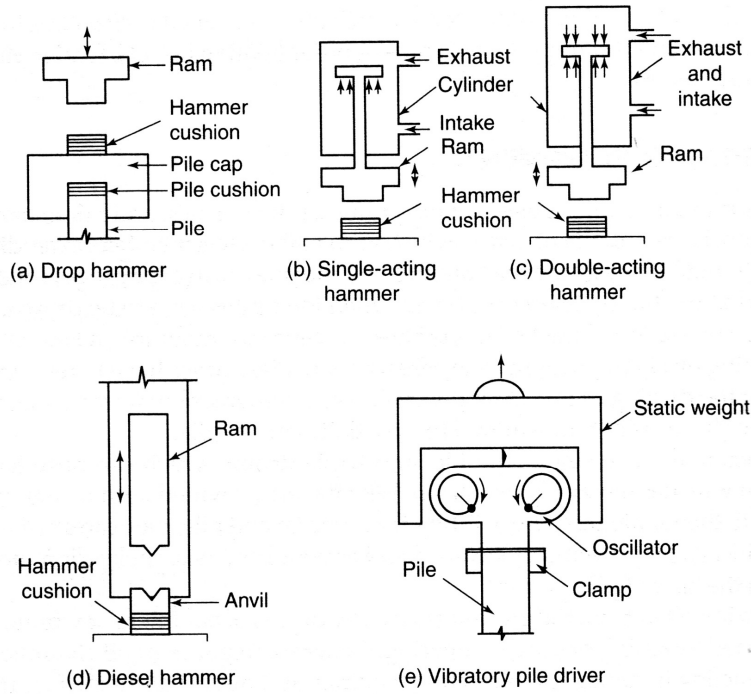


Figure 6.F.3 Principles of pile driving hammers

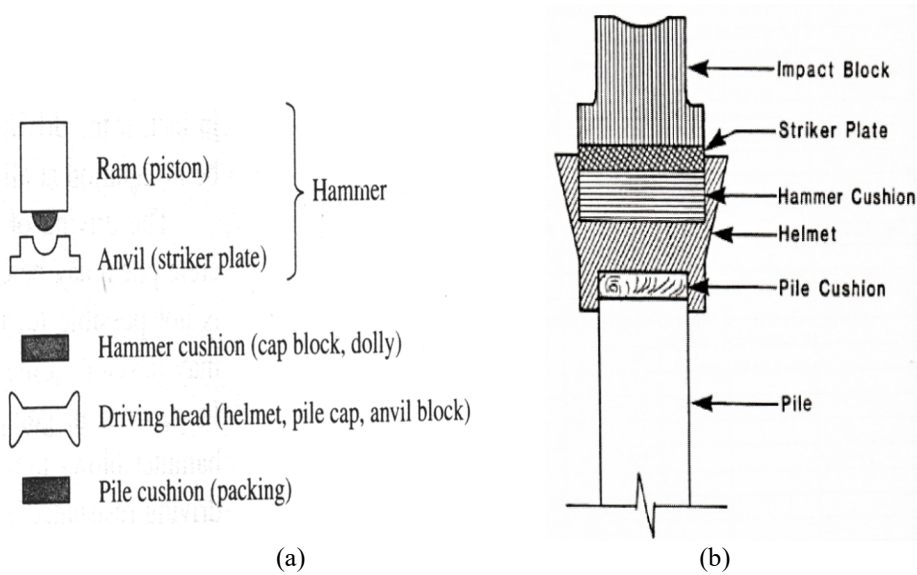


Figure 6.F.4 (a) Driving system components; (b) Positioning of the components

F.7 Driving Procedures

As mentioned earlier, the key to efficient pile driving is a good match of the pile with the hammer and other driving system components. When this is done, the operator will not be forced to try anything out of the ordinary to drive the piles to the required depth. For example, if an excessively light drop hammer is used, the operator may feel compelled to raise the hammer to excessive heights, which may in turn damage concrete piles. Mismatches of this sort quite often result either in inability to drive the pile as specified or in pile damage.

When using drop hammers, the key decision is the weight of the hammer. A drop hammer is typically a cylindrical weight that is raised to a certain height using a winch and dropped on top of the pile. The weight of drop hammer ranges from one half to twice the pile weight. The corresponding drop heights are in the 0.2 to 2m range. It is usually preferable to select heavier rather than lighter hammers, as the drop heights are then smaller and the likelihood of damage to concrete piles, in particular, is much lower. The ratio of hammer weight to pile weight for other types of hammer lies in the range of 0.25 to 1.0, but the selection of a suitable hammer also depends on other factors and is best done with the aid of computer-based drivability analysis. For example, the energy delivered by diesel hammers to piles increases with the driving resistance; in fact, if the driving is too easy, as in the first few meters in soft clays, there may be no ignition at all in the hammer, which would make it very inefficient.

The driving of precast concrete piles is probably the most challenging. Concrete piles may be damaged when driven through soft or loose soil, something that is not possible for either timber or steel piles. This is so because tensile stresses may develop in the pile under the conditions stated and, concrete is very weak in tension. In general, in going through soft/loose soil layers, the operator should use light hammer blows to avoid this. As a general rule, light blows are always used when driving resistance is small.

Immediately after driving, the pile resistance may be either higher or lower than the resistance it will ultimately have. The process by which pile resistance increases with time after driving is referred to as setup or freeze. When pile resistance decreases with time after driving, the process is referred to as relaxation. At least approximate estimation of the rate at which these processes take place is important to plan continuing pile driving around previously driven piles, to plan and perform load tests, and to take account in design of the real, long term resistance of the pile.

F.8 Pile Hammer Selection Guidelines

Selection of pile and pile hammer is usually done using wave equation program. If wave analysis is not done following Tables 6.F.2(a) and 6.F.2(b) may be used as an approximate guide. (Tables 6.F.2(a) and 6.F.2(b) were prepared by adapting the Table presented in “Pile Driving Equipment”, US Army Corps of Engineers, July 1997.)

Table 6.F.2(a): Guidelines for Selection of Pile Hammers: Sandy Soils

SPT (N) Value	Soil Density	Open End Pipe Piles	Closed End Pipe Piles	H-Piles	Sheet Piles	Concrete Piles
0 - 3	Very Loose	DA, SA, V (A, S, H)	DA, SA, V (A, S, H)	DA, SA, V (A, S, H)	DA, SA, V (A, S, H)	DA, SA (A, S, H)
4 - 10	Loose	DA, SA, V (A, S, H)	DA, SA, V (A, S, H)	DA, SA, V (A, S, H)	DA, SA, V (A, S, H)	DA, SA (A, S, H)
10 - 30	Medium	DA, SA, V (A, S, H)	DA, SA, V (A, S, H)	DA, SA, V (A, S, H)	DA, SA, V (A, S, H)	DA, SA (A, S, H)
30 - 50	Dense	DA, SA, V (A, S, H)	SA, V (A, S, H)	SA, V (A, S, H)	DA, SA, V (A, S, H)	SA (A, S, H)
Over 50	Very Dense	SA (A, S, H)	SA (A, S, H)	SA (A, S, H)	DA, SA, V (A, S, H)	SA (A, S, H)

LEGEND: DA = Double Acting; SA = Single Acting; A = Air/Diesel; S = Steam; H = Hydraulic; V = Vibratory

Table 6.F.2(b): Guide lines for Selection of Pile Hammers: Clayey Soil

SPT (N) Value	Soil Density	Open End Pipe Piles	Closed End Pipe Piles	H-Piles	Sheet Piles	Concrete Piles
0 - 4	Soft	DA, SA, V (A, S, H)	DA, SA (A, S, H)	DA, SA, V (A, S, H)	DA, SA, V (A, S, H)	DA, SA (A, S, H)
4 - 8	Medium	DA, SA, V (A, S, H)	SA (A, S, H)	DA, V (A, S, H)	DA, SA, V (A, S, H)	SA (A, S, H)
8 - 15	Stiff	DA, SA (A, S, H)	SA (A, S, H)	DA, SA (A, S, H)	DA, SA (A, S, H)	SA (A, S, H)
15 - 30	Very Stiff	SA (A, S, H)	SA (A, S, H)	SA (A, S, H)	SA (A, S, H)	SA (A, S, H)
Over 30	Hard	SA (A, S, H)	SA (A, S, H)	SA (A, S, H)	SA (A, S, H)	SA (A, S, H)

General Guidelines for Selecting a Pile Hammer

Single Acting Steam and Air/Diesel Hammers

- * Dense sands and stiff clays need heavy hammers with low blow counts. This makes single acting hammers ideal for such situations.

Double Acting Steam and Air Hammers

- * Double acting hammers have light hammers compared to single acting hammers with same energy level. Light hammers with high velocity blows are ideal for medium dense sands and soft clays.

Vibratory Hammers

- * Avoid vibratory hammers for concrete and timber piles. Vibratory hammers could create cracks in concrete.
- * Avoid vibratory hammers for clayey soils. Vibratory hammers are best suited for loose to medium sands.
- * Vibratory hammers are widely used for sheet piles since it may be necessary to extract and reinstall piles. Extraction of piles can be readily done with vibratory hammers.
- * In loose to medium soil conditions, sheet piles can be installed at a much faster rate by vibratory hammers.

Hydraulic Hammers:

- * Hydraulic hammers provide an environmental friendly operation. Unfortunately rental cost is high for these hammers.

F.9 Noise Level In Pile Driving

Another important aspect of selection of pile driving method is the noise level. Following Table 6.F.3 is provided by White et. al. (2000) as a guide for noise produced during pile driving by selected methods.

Table 6.F.3 Guidelines for Noise Level during Pile Driving

Installation Method	Observed Noise Level (dB)	Distance of Observation (m)
Pressing (Jacking)	61	7
Vibratory (Med. Fre.)	90	1
Drop Hammer	98-107	7
Light Diesel Hammer	97	18

F.10 Construction of Bored Cast-In-Situ Pile/ Drilled Shaft

Bored Cast-in-situ piles/shafts are very much preferred in cities as they do not cause any disturbance to surroundings. In bored cast in-place piles, the holes are first bored with a temporary or permanent steel casing or by using bentonite slurry to stabilize the sides of the bore. Holes can also be formed by augers. A prefabricated steel cage is then lowered into the hole and concreting is carried by the tremie method. Boring holes by using bentonite mud is much more popular than using casing pipes. One of the great advantages of this method is that large diameter piles (up to 5 m diameter) can be installed by this method. Hence, these piles are very much used for bridges and other heavy structures. However, it should be clearly remembered that bored piles smaller than 400 mm in diameter are not normally recommended for use in practice. The sides of cast in-situ small diameter piles are liable to cave in. In such cases, there will be no continuity in the length of piles. In the following Sections methods of advancing the holes, choice of tools to be used and other related topics described by Varghese (2005) are reproduced.

F.10.1 Method of Advancing the Hole for Bored Pile/Drilled Shaft

There are various methods of advancing bore holes with the circulation of bentonite. Some of these methods are now discussed.

Method 1: Piles installed by bailer and cutting tools: This is crude but the simplest method of advancing the hole when using the chisel and bailer bucket to advance the hole. The slurry is formed by simply adding the bentonite into the hole and mixing it in the hole, with the level of the suspension inside the bore hole always kept about 1 m above the ground water level, or if necessary to the top of the level of the casing. When meeting cohesionless materials, the slurry may be thickened. The aim is to help the stabilization of hole by forming an impermeable thin film around the bore hole. The bentonite suspension is assumed to penetrate into the sides under positive pressure. After a while it forms a jelly, thus making the sides impervious by producing a plastering effect. This is described as a crude method of installing bored piles because adding bentonite in the hole as in this method does not give us the full benefit of piling. The up and down movements of the bailer cause the soil from the sides and bottom to flow in. It is also very difficult to remove all the loose materials that collect at the bottom in the end. Hence as far as possible, the bailer method should not be used on important works.

Method 2: Continuous mud circulation (CMC) method (Figure 6.F.5). This method is a more refined one than the above method. In this case, bentonite of sufficient viscosity and velocity (as delivered by a mud pump) is maintained in continuous circulation so that particles are suspended in the mud and brought to the surface by the flow of

bentonite. The level of the bentonite suspension is kept constant. For this purpose, a mud pump of sufficient capacity (depending on diameter and depth of hole) is employed for continuous circulation. Material in the bore hole is loosened (spoil formed) by means of a suitably designed chopper or reamer or drilling bit. The bentonite solution is circulated by pumping. It serves the two purposes of (a) stabilizing the bore hole and (b) conveying the spoil from bottom of the hole to the top. The mud pump capacity should be able to maintain the volume and velocity to lift up the spoil from the bore hole. It will depend on the diameter and depth of the hole to be bored. The mud pump may be used in the following four different ways:

- (i) Direct mud circulation (DMC): In this method, the bentonite suspension is pumped into the bottom of the hole through the drill rods and it overflows at the top of the casing. The mud pump should have the capacity to maintain a velocity of 0.41 to 0.76 metres per second to float the cuttings.
- (ii) Reverse mud circulation (RMC): For large diameter holes, the pump is more efficient if the bentonite suspension is fed directly at the top of the hole and it is pumped out from bottom of the hole with suitable rotary pump fitted at the bottom of the drill rods. This method is called the reverse mud circulation method. Whereas borehole sizes in direct circulation are limited by the mud pump capacity, in reverse circulation method even a medium sized pump can create enough bailing velocity to bring cuttings up and the inner diameter of the drill pipe need not be large.
- (iii) Rapid direct mud circulation (RDMC): This is an improved version of the DMC where a tube carrying compressed air is also sent to the bottom of the bore. The air helps in mixing up the loosened soil with the bentonite slurry more effectively so that even heavy particles are forced out of the bore suspended in the bentonite. However, in all cases where rapid excavation of the bore is planned, the tendency of sides to cave in should be carefully examined.
- (iv) Air lift reverse mud circulation drilling (ARMC): This method of drilling is used for large diameter holes. Compressed air is used in this method to circulate the drilling fluid and cuttings to the surface.

It has also been observed in the field that with bentonite clay there is more caving in during the time there is no work than during the working period. This may perhaps be due to thickening of the bentonite into a gel when not in agitation. This gel may exert less lateral pressure than bentonite in liquid mud form. Hence concreting of holes should be planned immediately after circulation of bentonite and never in a hole, in which work was suspended overnight.

F.10.2 Limitations of Bentonite Method

The bentonite method has some limitations. A brief list of these is as follows:

- (i) Pile diameters should not be small. Normally, they should be 400 mm to 5 in in diameter.
- (ii) It will have potential danger if used in artesian conditions.
- (iii) It is difficult to use this method in soils with permeability greater than 1 in per second or in soft clays with shear strength less than 20 kN/m².
- (iv) It is difficult to clean the bottom of the hole when boring ends in coarse materials, disintegrated rocks, etc. which do not come up easily along with the suspension.
- (v) It is difficult to install raker piles by this method.
- (vi) In non-cohesive soils or fine sands, the rate of progress of work should be slow enough for the bentonite to penetrate into the soil and produce the plastering effect. The rate of progress should be suitably adjusted. Otherwise side collapse may occur.
- (vii) If subsoil or ground water contains salts, it will adversely affect the action of bentonite. Protection of sides from caving in may be found to be difficult.

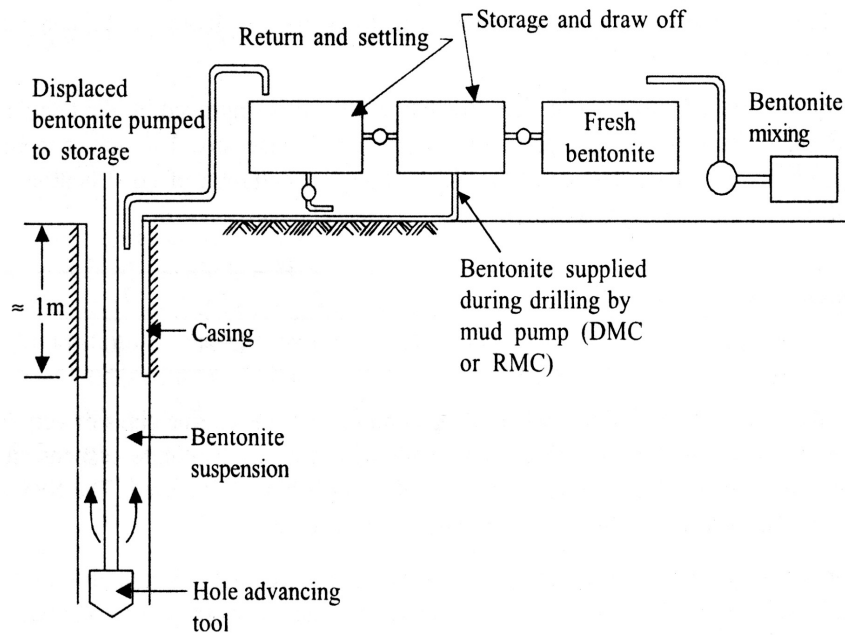


Figure 6.F.5 Schematic diagram and layout of equipment for boring using bentonite suspension (after Varghese, 2005).

F.10.3 Actions to be Taken Prior to Concreting

The following precautions are very important for success in the construction by bentonite stabilization:

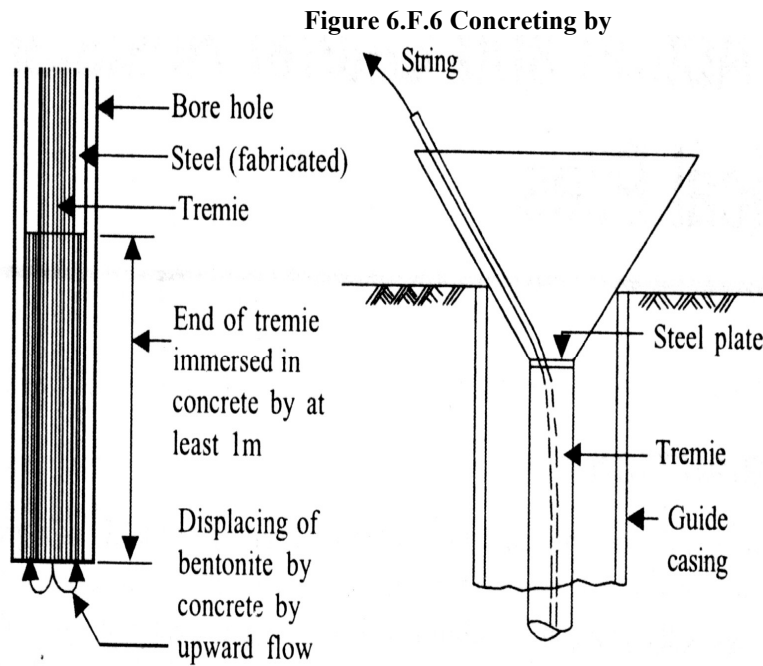
- (i) The specific gravity of bentonite should be checked at intervals by taking samples from the bottom. If it exceeds 1.25, replacement of bentonite at the bottom may be necessary without decreasing the level of bentonite in the hole. The density should be brought down to about 1.12 by flushing before concreting.
- (ii) As the tendency of caving in is more, when the bentonite is not in circulation, operations for final concreting should always start as soon as the hole is completed and cleaned.
- (iii) Before the steel cage is lowered, the hole should be flushed with fresh bentonite slurry for at least 15 minutes (in direct circulation by the mud circulation chisel resting at the bottom) so that it is completely cleared. Accumulated debris at the bottom can considerably increase the settlement when the piles are loaded. This aspect is very important in construction of bored cast in-situ piles. Many load tests (especially in bearing piles) have produced inconsistent results due to carelessness in cleaning the bottom of the hole before concreting.

F.10.4 Concreting of Piles

The precautions to be taken in the use of tremie concrete in piles. After cleaning the holes, the reinforcement cage is lowered into the hole. The bore is once again flushed and concrete poured through a tremie pipe of 200 mm in diameter. Concrete of slump 150 mm, cement content not less than 400 kg/m³, water cement ratio > 0.5, maximum size of aggregate 20 to 25 mm with suitable plasticizer is recommended for use. The procedure is as follows:

First, a guide casing, if not already provided, is placed over the hole for proper seating of the tremie funnel. The tremie is lowered to the bottom of the hole. To start with, the bottom of concreting funnel is closed with a steel plate. After filling the funnel to its full capacity the steel plate is removed and concrete discharged. The bottom of the tremie should always be at least 2 m within the concrete so that the bentonite is replaced from bottom upwards. Only the initially poured concrete is in contact with the bentonite as shown in Figure 6.F.6. Concreting is carried out to at least 60-90 cm above the cut off level. If the cut off level is at the ground level the top concrete is allowed to spill over till good concrete is visible.

When bentonite piling was introduced before its final adoption, much doubt was raised about the strength of concrete placed in bentonite (which is a suspension of clay) as well as about the bond characteristics of steel that have been coated with bentonite. However, tests have shown that placing concrete by displacing bentonite suspension from bottom (in contrast to pouring concrete into bentonite suspension) does not affect concrete strength. Similarly the bond between steel and concrete is also not very much reduced in this process. Hence the importance of properly placing concrete by tremie by displacement of bentonite from bottom up should be strictly followed in the field.



Varghese, 2005)

tremie (after

PART VI
Appendix G

Other Methods of Estimating Ultimate Axial Capacity of Piles and Drilled Shafts, and Design Charts for Settlement

G.1 Method Based on the Standard Penetration Test (Canadian Foundation Engineering Manual):

This method is based on N-values obtained from Standard Penetration Test (SPT). This method has been described in Canadian Foundation Engineering Manual published by Canadian Geotechnical Society (CGS, 1985).

The capacity of a single pile in granular soils can be estimated from the results of SPT using the following expression as suggested by Meyerhof (1976).

$$R = mNA_t + nN'DA_s \quad (6.G.1)$$

Where,

- R = pile capacity (N)
 m, n = constants depending on type of pile (driven or cast-in-situ bored piles)
 N = SPT index at the pile toe
 A_t = pile toe area
 N' = average SPT index along the pile
 D = pile embedment length
 A_s = pile unit shaft area

The Standard Penetration Test is subject to a multitude of errors, and a lot of care must be exercised when using test results. For this reason, in this method a minimum factor of safety of 4 should be applied to calculate allowable capacity of a drilled shaft or bored pile.

G.2 Method Based on the Theory of Plasticity (Canadian Foundation Engineering Manual)

In this method the capacity of a single pile may be determined from the friction angle of the soil by use of the theory of plasticity (or bearing-capacity theory).

The capacity of a pile in a soil of uniform density increases in a linear manner with increase in effective overburden pressure at least to a certain depth called the critical depth. Investigations of single piles indicate that there is very little increase in toe resistance or unit shaft resistance below the critical depth. The ratio of the critical depth to the pile diameter increases with increase in the angle of shearing resistance. For most applications, the ratio ranges between a value of 7 at $\phi' = 30^\circ$ to a value of 22 at $\phi' = 45^\circ$.

The ultimate static resistance, R of a single pile is a function of the sum of the toe and shaft resistance, R_t and R_s , as follows:

$$R = R_t + R_s \quad (6.G.2)$$

Where for toe resistance:

$$R_t = A_t r_t = A_t \sigma'_D N_t \quad (6.G.3)$$

Where,

A_t = cross-sectional area of pile at toe

r_t = unit toe resistance = $\sigma'_D N_t$

σ'_D = unit effective vertical stress at the pile toe = $\gamma'D$ (below the critical depth, $D = D_c$)

γ' = submerged unit weight of soil

D = embedment length of the pile in soil

N_t = bearing-capacity coefficient as recommended by Canadian Foundation Engineering Manual

The expression for shaft resistance is as follows:

$$R_s = \sum_{Z=0}^D A_s r_s = \sum_{Z=0}^D A_s \beta \sigma'_z = \sum_{Z=0}^D A_s M K_s \tan \phi' \sigma'_z \quad (6.G.4)$$

Where,

A_s = shaft area per unit length of pile

r_s = unit shaft resistance along the pile

σ'_z = effective vertical stress at depth z (below the critical depth, $z = D_c$, use σ'_z)

β = shaft resistance coefficient = $K_s M \tan \phi'$

K_s = ratio between the horizontal effective soil stress to the vertical effective soil stress at the pile shaft

$M = \tan \delta' / \tan \phi'$

$\tan \phi'$ = soil friction

$\tan \delta'$ = soil-pile friction

The value of K_s is influenced by the angle of shearing resistance, the method of installation, the compressibility and original state of stress in the ground, and the size and shape of the pile. It increases with the in-situ density and angle of shearing resistance of the soil and with the amount of displacement. It is higher for displacement-type piles than for low-displacement-type piles such as H-piles. For bored piles, the value of K_s is usually assumed equal to the coefficient of earth pressure at rest, K_0 . For driven displacement-type piles, the value of K_s is normally assumed to be twice the value of K_0 .

The value of M ranges from 0.7 to 1.0, depending on the pile material (steel, concrete, wood) and method of installation (Bozozuk et al., 1978). The combined shaft resistance coefficient, β , is generally assumed to range from 0.3 to 0.8, where the lower value is used in clay and silt, and the higher value in coarse and dense soils (Burland, 1973).

Terzaghi and Peck (1967) reported typical values of angle of internal friction for different types of sands which are shown in Table 6.G.1. In the absence of test loading, this method recommends a factor of safety of at least 3 in order to calculate the allowable capacity.

Table 6.G.1: Typical Values of Angle of Internal Friction for Different Types of Sand (after Terzaghi and Peck, 1967)

Type of Sand	Angle of Internal Friction, ϕ'	
	Loose	Dense
Uniform sand, rounded particles	27°	35°
Well graded sand, angular particles	33°	45°
Sandy gravels	35°	50°
Silty sands	27° to 30°	30° to 34°
Inorganic silts	27° to 30°	30° to 35°

G.3 Tomlinson Method

This method of estimating ultimate axial load capacity of a single pile has been described by Tomlinson (1995). In this method, the design ultimate unit skin friction of an individual pile is given by the following expression:

$$q_z = K_s \sigma'_{vo} \tan \delta \quad (6.G.5)$$

Where, K_s = coefficient of horizontal soil stress,

σ'_{vo} = average effective overburden pressure over the length of the soil layer

δ = angle of wall friction

The value of coefficient K_s is related to the coefficient of earth pressure at rest (K_o) and also to the method of installation of the piles. Values of coefficient of horizontal soil stress (K_s) are shown in Table 6.G.2 while values of the angle of pile to soil friction (δ) for various interface conditions are shown in Table 6.G.3.

Table 6.G.2: Values of Coefficient of Horizontal Soil Stress, K_s (after Kulhawy, 1984)

Installation method	K_s/K_o
Driven piles, large displacement	1-2
Driven piles, small displacement	0.75-1.75
Bored and cast-in-place piles	0.71-1.0
Jetted piles	0.5-0.7

Table 6.G.3: Values of Soil Pile Friction Angle (δ) for Various Interface Conditions (after Kulhawy, 1984)

Pile/soil interface condition	Angle of pile to soil friction (δ)
Smooth (coated) steel/sand	$0.5\phi'$ to $0.7\phi'$
Rough (corrugated) steel/sand	$0.7\phi'$ to $0.9\phi'$
Precast concrete/sand	$0.8\phi'$ to $1.0\phi'$
Cast-in-place concrete/sand	$1.0\phi'$
Timber/sand	$0.8\phi'$ to $0.9\phi'$

The equation for estimating ultimate skin friction implies that in a uniform cohesionless soil the unit skin friction continues to increase linearly with increasing depth. This is not the case. Vesic (1970) showed that at some penetration depth between 10 and 20 pile diameters, a peak value of unit skin friction is reached which is not exceeded at greater penetration depths. Research has not yet established whether the peak value is a constant in all conditions, or is related to factors such as soil grain size or angularity. A peak value of 110 kN/m^2 has been recommended by Tomlinson (1995) for straight-sided piles.

The base resistance is obtained from the following equation:

$$Q_b = q_b A_b = N_q \sigma'_{vo} A_b \quad (6.G.6)$$

Where, N_q = bearing capacity coefficient

σ'_{vo} = average effective overburden pressure over the length of the soil layer

A_b = base area of pile

Comparisons of observed base resistances of piles by Nordlund (1963) and Vesic (1964) have shown that N_q values established by Berezantsev (1961) which take into account the depth to width ratio of the pile most nearly conform to practical criteria of pile failure.

G.4 Design Charts for Estimation of Settlement for Drilled Shafts

Reese and O'Neill (1988) developed the following charts, (Figures 6.G.1 to 6.G.4), to estimate the settlement of drilled shaft under service loads. These charts express the settlement in terms of the ratio of the mobilized resistance to the actual resistance. If the computed settlement is too large, these charts may be used to modify the design accordingly. It is important to mention that the notation used in these charts, in several instances, differ from that mentioned in the Code. They are indicated as under and should be carefully considered.

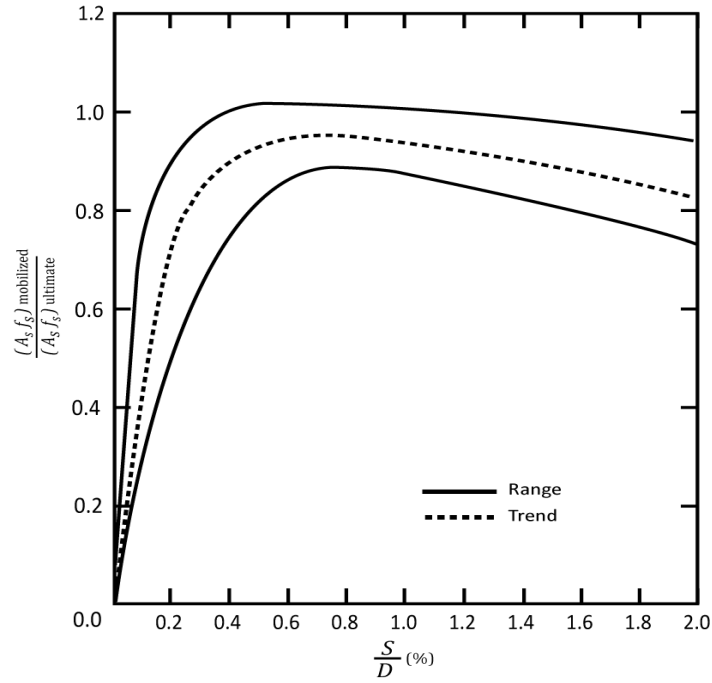


Figure 6.G.1 Normalised Curves for Load Transfer in Skin Friction vs Settlement for Drilled Shafts in Cohesive Soils (after Reese and O’Nell, 1988)

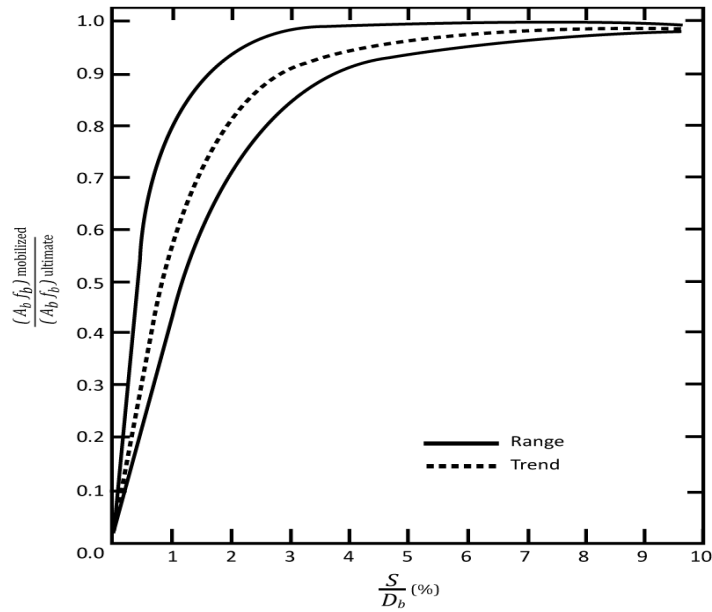


Figure 6.G.2 Normalised Curves for Load Transfer in End Bearing vs Settlement for Drilled Shafts in Cohesive Soils (after Reese and O’Nell, 1988)

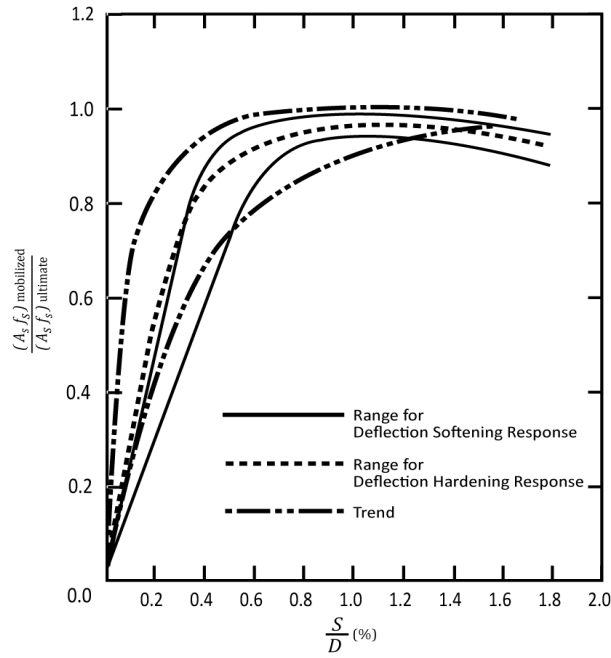


Figure 6.G.3 Normalised Curves for Load Transfer in Skin Friction vs Settlement for Drilled Shafts in Cohesionless Soils (after Reese and O’Neil, 1988)

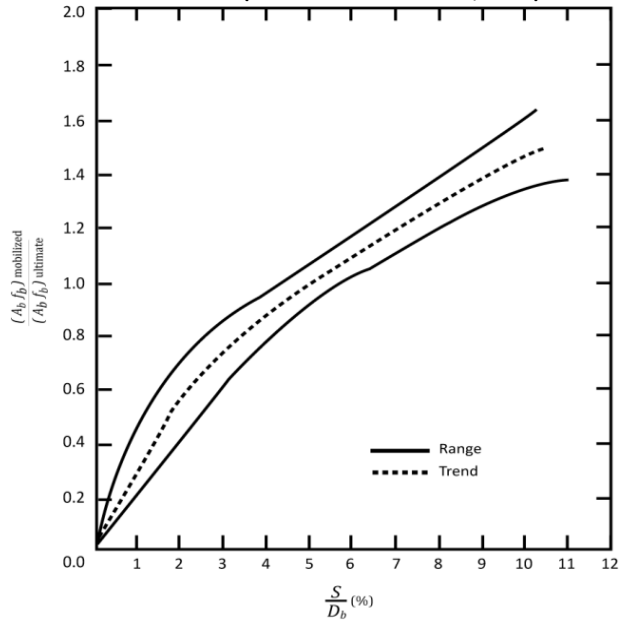


Figure 6.G.4 Normalised Curves for Load Transfer in End Bearing vs Settlement for Drilled Shafts in Cohesionless Soils (after Reese and O’Neil, 1988)

PART VI
Appendix H

References of Chapter 3 Part 6 (Soils and Foundations)

ASTM D1143-07 (2012), Standard Test Method for Deep Foundations Under Static Axial Compressive Load, Annual Book of ASTM Standards, Vol. 04.08, ASTM International, pp. 108-122.

ASTM D1557-09 (2012), Standard Test Methods for Laboratory Compaction Characteristics of Soil Using Modified Effort, Annual Book of ASTM Standards, Vol. 04.08, ASTM International, pp. 143-173.

ASTM D1586-11 (2012), Standard Test Method for Standard Penetration Test (SPT) and Split-Barrel Sampling of Soils, Annual Book of ASTM Standards, Vol. 04.08, ASTM International, pp. 161-167.

ASTM D2487-11 (2012), Standard Practice for Classification of Soils for Engineering Purposes (Unified Soil Classification System), Annual Book of ASTM Standards, Vol. 04.08, ASTM International, pp. 268-279.

ASTM D2573-08 (2012), Standard Test Method for Field Vane Shear Test in Cohesive Soil, Annual Book of ASTM Standards, Vol. 04.08, ASTM International, pp. 291-298.

ASTM D2974-07a (2012), Standard Test Methods for Moisture, Ash, and Organic Matter of Peat and Other Organic Soils, Annual Book of ASTM Standards, Vol. 04.08, ASTM International, pp. 339-342.

ASTM D3441-05 (2012), Standard Test Method for Mechanical Cone Penetration Tests of Soil, Annual Book of ASTM Standards, Vol. 04.08, ASTM International, pp. 395-400.

ASTM D3689-07 (2012), Standard Test Method for Deep Foundations Under Static Axial Tensile Load, Annual Book of ASTM Standards, Vol. 04.08, ASTM International, pp. 408-420.

ASTM D3966-07 (2012), Standard Test Method for Deep Foundations Lateral Load, Annual Book of ASTM Standards, Vol. 04.08, ASTM International, pp. 434-451.

ASTM D4318-10 (2012), Standard Test Methods for Liquid Limit, Plastic Limit, and Plasticity Index of Soils, Annual Book of ASTM Standards, Vol. 04.08, ASTM International, pp. 592-607.

ASTM D4380-12 (2012), Standard Test Method for Density of Bentonitic Slurries, Annual Book of ASTM Standards, Vol. 04.08, ASTM International, pp. 617-618.

ASTM D4428-07 (2012), Standard Test Methods for Crosshole Seismic Testing, Annual Book of ASTM Standards, Vol. 04.08, ASTM International, pp. 660-670.

ASTM D4719-07 (2012), Standard Test Methods for Prebored Pressuremeter Testing in Soils, Annual Book of ASTM Standards, Vol. 04.08, ASTM International, pp. 916-925.

ASTM D4972-07 (2012), Standard Test Method for pH of Soils, Annual Book of ASTM Standards, Vol. 04.08, ASTM International, pp. 1024-2026.

ASTM D5777-00 (2012), Standard Guide for Using the Seismic Refraction Method for Subsurface Investigation, Annual Book of ASTM Standards, Vol. 04.08, ASTM International, pp. 1572-1585.

ASTM D5778-12 (2012), Standard Test Method for Electronic Friction Cone and Piezocone Penetration Testing of Soils, Annual Book of ASTM Standards, Vol. 04.09, ASTM International, pp. 1586-1604.

ASTM D5882-07 (2012), Standard Test Method for Low Strain Impact Integrity Testing of Deep Foundations, Annual Book of ASTM Standards, Vol. 04.09, ASTM International, pp. 69-74.

ASTM D6066-11 (2012), Standard Practice for Determining the Normalized Penetration Resistance of Sands for Evaluation of Liquefaction Potential, Annual Book of ASTM Standards, Vol. 04.09, ASTM International, pp. 328-343.

ASTM D6910-09 (2012), Standard Test Method for Marsh Funnel Viscosity of Clay Construction Slurries, Annual Book of ASTM Standards, Vol. 04.09, ASTM International, pp. 1049-1051.

ASTM G57-06 (2012), Standard Test Method for Field Measurement of Soil Resistivity Using the Wenner Four-Electrode Method, Annual Book of ASTM Standards, Vol. 03.02, ASTM International, pp. 223-227.

BDS 819:1975 (1975), Code of Practice for Preservation of Timber, Bangladesh Standards and Testing Institution.

Berezantzev, V.G., Kristofornov, V. and Golubkov, V. (1961), Load Bearing Capacity and Deformation of Pile Foundation, Proceedings of the 5th International Conference on Soil Mechanics, Paris, Vol. 2, pp.11-12.

Borden, R. H., and Gabr, M.A. (1987), Analysis of Compact Pole-Type Footing-LT Base: Computer Program for Laterally Loaded Pier Analysis Including Base and Slope Effect, Raleigh, N.C., North Carolina Department of Transportation, USA.

- Bowles, J.E. (1988), *Foundation Analysis and Design*, 4th Edition, McGraw Hill Book Company, Singapore.
- Bozozuk, M., Fellenius, B.H. and Samson, L., (1978), Soil disturbance from Pile Driving in Sensitive Clay, *Canadian Geotechnical Journal*, Vol. 15, No. 3, pp. 346-361.
- Brinch-Hansen, J. (1963), Hyperbolic Stress Strain Response: Cohesive Soils, Discussion, *JSMFED, ASCE*, Vol. 89, No. SM4, pp. 241-242.
- BS 8004: 1986 (1986), *Code of Practice for Foundations*, British Standards Institution (current version: BS EN 1997-1:2004, Euro Code 7 Geotechnical Design General Rules).
- Burland, J.B. (1973), "Shaft Friction of Piles in Clay : A simple Fundamental Approach", *Ground Engineering*, Foundation Publications Ltd., London, Vol. 6, No. 3, pp. 30-42.
- Butler, H.D. and Hoy, H.E. (1977), *User's Manual for the Texas Quick Load Method for Foundation Load Testing*, FHWA-IP-77-8, Federal Highway Administration, Office of Development, Washington, pp.59 .
- CGS (1985), *Canadian Foundation Engineering Manual*, 2nd Edition, Canadian Geotechnical Society, Toronto
- Chellis, R.R. (1961), *Pile Foundation*, 2nd Edition, McGraw Hill, New York.
- Chen, F.H. (1975), *Foundation on Expansive Soils*, *Developments in Geotechnical Engineering* Vol. 12, 1st Edition, Elsevier Science Publishers B.V., Netherlands.
- Clayton, C.R.I., Simons, N.E. and Matthews, M.C. (1982), *Site Investigation*, Granada Publishing Limited, London.
- Coduto, D.P. (1994), *Foundation Design Principles and Practice*, Prentice Hall, Englewood Cliff, New Jersey, USA, pp. 322.
- Davisson, M.T. (1973), *High Capacity Piles: Proc. Of Lecture Series on Innovation in Foundation Construction*, Soil Mechanics Division, Illinois Section, ASCE, Department of Civil Engineering, Illinois Institute of Technology, Chicago, IL, 1973.
- Douglas, B.J. and Olsen, R.S. (1981), *Soil Classification using the Electric Cone Penetrometer Test*, *Cone Penetration Testing and Experience*, ASCE Fall Convention, 1981.
- Douglas, B.J. (1984), *The Electric Cone Penetrometer Test: A User's Guide to Contracting for Services, Quality Assurance, Data Analysis*, The Earth Technology Corporation, Long Beach, CA, USA.

- Edil, T.B. (1997), Construction over Peats and Organic Soils, Proc. Conf. On Recent Advances in Soft Soil Engineering, Kuching, Sarawak, Malaysia, March, 1997, pp. 85-108.
- Finn, W.D.L., Ledbetter, R.H., and Wu, G. (1994), Liquefaction in Silty Soils: Design and Analysis, Ground Failures under Seismic Conditions, Geotechnical Special Publication, ASCE, 1994, pp. 51-76.
- Fuller, F.M. (1983), Engineering of Pile Installation, McGraw Hill Book Co., New York, USA, pp. 286.
- Gibbs, H.J. and Holtz, W.G. (1957), Research on Determining the Density of Sands by Spoon Penetration Testing, Proc. 4th ICSMFE, Vol. 1, London, UK, pp. 35-39.
- Hannigan, P. J., Goble, G.G., Thendean, G., Likens, G.E. and Rauche, F. (1998), Design and Construction of Driven Pile Foundations, Vols. I & II, FHWA H 97-013 & FHWA H 97-014, DOT, USA.
- Hossain, M. M. (1983), Swelling Properties of Selected Local Soils, M. Sc. Engineering thesis, Department of Civil Engineering, Bangladesh University of Engineering and Technology, Dhaka, Bangladesh.
- Hvorslev, M.J. (1949), Subsurface Exploration and Sampling of Soils for Civil Engineering Purposes, Waterways Experimental Station, Vicksburg, Mississippi.
- ISSMFE (1965), Report of the Subcommittee on Problems and Practices of Soil Sampling, Proc., 6th ICSMFE, Montreal, Vol. 3, Appendix II, pp. 64-71.
- IS: 1948 (1972), Classification and Identification of Soils for General Engineering Purposes, Bureau of Indian Standards, New Delhi.
- IS: 2911, Part 3 (1980), Code of Practice for Design and Construction of Pile Foundations: Under reamed Piles (First Revision), Bureau of Indian Standards, New Delhi.
- IS: 2911 – Part 1 (1979), Design and Construction of Pile Foundations- Driven Cast In Situ Concrete Piles, Bureau of Indian Standards, 1979.
- IS: 2911 – Part 4 (1979), Load Test on Piles, Bureau of Indian Standards, 1979.
- IS: 2974-Part 1 (1982), Foundations for Reciprocating Type Machines, Bureau of Indian Standards, 1982.
- Kallstenius, T. (1958), Mechanical Disturbances in Clay Samples Taken With Piston Samplers, Proc., Royal Swedish Geotechnical Institute, No. 16, pp. 1-75.

Klingmuller, O. (1993), *Dynamische Integritätsprüfung und Qualitätssicherung bei Bohrfählen*, Geotechnik 16, Verlag Gluckauf (in German).

Kulhawy, F.H. (1984), Limited tip and side Resistance : Fact or Fallacy, Proceedings of the Symposium on Analysis and Design of Pile Foundations, ASCE, San Francisco, pp. 80-98.

Kulhawy, F.H. and Jackson, C.S. (1989), Some Observations on Undrained Side Resistance of Drilled Shafts, *Foundation Engineering: Current Principles and Practices*, pp. 1011-1014, ASCE.

Kulhawy, F.H. and Mayne, P.W.. (1990), *Manual on Estimating Soil Properties for Foundation Design*, Report No. EL-6800, Electric Power Research Institute, Palo Alto, CA, USA.

Look, B.G. (2007), *Handbook of Geotechnical Investigation and Design Tables*, First Edition, Taylor & Francis, London, pp. 81.

Meyerhof, G.G. (1976), Bearing capacity and Settlement of Pile Foundations, The Eleventh Terzaghi Lecture, *Journal of Geotechnical Engineering Division, ASCE*, Vol. 102, GT3, pp. 195-228.

NBCI (2005), *National Building Code of India*, Bureau of Indian Standards, New Delhi.

Nordlund, R.L. (1963), Bearing Capacity of Piles in Cohesionless Soils, *Journal of Soil Mechanics and Foundation Division, ASCE*, Vol. 89, No. SM3, pp. 1-35.

Peck, R.B., Hanson, W.E. and Thornburn, T.H. (1974), *Foundation Engineering*, 2nd Edition, John Wiley & Sons, Inc., New York, USA.

Poulos, H. G. and Davis, E.H. (1980), *Pile Foundation Analysis and Design*, John Wiley and Sons, NY, USA.

Reese, L. C., Cooley, L. A., and Radhakrishnan, N. (1984), *Laterally Loaded Piles and Computer Program COM624G*, Technical Report K-84-2, U.S. Army Engineer Division, Lower Mississippi Valley, Vicksburg, MS, 1984.

Reese, L.C. and O'Neill, M.W. (1988), *Drilled Shafts: Construction Procedures and Design Methods*, Report No. FHWA-HI-88-042, Federal Highway Administration, USA.

Richart, F.E. Jr. (1962), *Foundation Vibrations*, *Trans ASCE*, Vol. 127, pp. 863-898, 1962.

Robertson, P.K. and Campanell, R.G. (1983a), Interpretation of Cone Penetration Tests, Part- Sand, *CBJ, Ottawa*, Vol. 20, No. 4.

- Robertson, P.K. and Campanell, R.G. (1983b), SPC-CPT Correlations, JSMFED, ASCE, Vol. 109.
- Salgado, R. (2011), The Engineering of Foundations, Tata McGraw Hill Edition, 2011, Tata McGraw Hill Education Private Limited, New Delhi.
- Sanglerat, G. (1972), The Penetrometer and Soil Exploration, Elsevier Publishing Co., Amsterdam, Netherlands.
- Seed, H.B., Woodward, R.J. and Lundgren, R. (1962), Prediction of Swelling Pressure for Compacted Clays, JSMFED, ASCE, Vol. 88.
- Sherard, J.L, Dunnigan, L.P., Decker, R.S. and Steele, E.F.(1976), Pinehole Test for Identifying Dispersive Soils, JGED, ASCE, Vol. 102 (GT 1), pp. 69-85.
- Terzaghi, K. (1942), Discussion of the Progress Report of the Committee on the Bearing Value of Pile Foundations, Proc. ASCE, Vol. 68, pp. 311-323.
- Terzaghi, K. and Peck, R.B. (1967), Soil Mechanics in Engineering Practice, 2nd Edition, John Wiley, New York, USA.
- Tomlinson, M.J. (1995), Pile Design and Construction Practice, E & FN Spon, London.
- Tomlinson, M.J. (1995), "Foundation Design and Construction", Sixth Edition, Wesley Longman Singapore Publishers (Private) Limited, Singapore.
- Varghese, P.C. (2005), Foundation Engineering, Prentice – Hall of India, New Delhi.
- Vesic, A.S. (1964), Investigations on Bearing Capacity of Piles in Sand, Duke University Soil Mechanics Laboratory Publication No. 3.
- Vesic, A.S. (1970), Tests on Instrumented Piles, Ogeechee River Site, JSMFED, ASCE, Vol. 96, No. SM2, pp. 561-584.
- Whitaker, T. (1963), The Constant Rate of Penetration Test for the Determination of the Ultimate Bearing Capacity of a Pile, Proceedings, Institution of Civil Engineers, Vol. 26, London, UK, 1963, pp. 119-123
- Whitaker, T. (1976), Design of Piled Foundation, 2nd Edition, Pergamon Press, Oxford, UK.
- White, D.J., Sidhu, H.K., Finlay, T.C.R., Bolton, M. D. and Nagayama, T. (2000), Press in Piling: The Influence of Plugging on Driveability, 8th International Conference of the Deep Foundations Institute, New York. pp 299-310.

PART VI
Appendix I
Strut-and-Tie Models

I.1 Scope and Definitions

Scope: Strut-and-Tie model is elaborated in this Appendix. Sec. I.1 introduces the basic definitions. The design procedure by Strut-and-Tie model is described in Sec. I.2. Strength of struts, ties and nodal zones are given in Sections I.3, I.4 and I.5 respectively. Definitions and clauses in the above sections are followed by clarifications as necessary.

B-region: A region of a member where the plane sections assumption of flexure theory from Sec 6.3.2.2 can be applied. In general, B-region is any portion of a member outside of a D-region.

Discontinuity: An abrupt change in loading or geometry.

Clarification for Discontinuity: It is assumed that discontinuities extend a distance h from the section where the load or change in geometry occurs. Figure 6.I.1(a) shows typical geometric discontinuities, and Figure 6.I.1(b) shows combined geometrical and loading discontinuities.

D-region: The region of a member within a distance, h , from a force discontinuity or a geometric discontinuity.

Clarification for D-region: Typical D-regions are the shaded regions in Figure 6.I.1(a) and Figure 6.I.1(b). The plane sections assumption of Sec 6.3.2.2 is not applicable in such regions. Each shear span of the beam in Figure 6.I.2(a) is a D-region.

When two D-regions overlap or meet as shown in Figure 6.I.2(b), they can be considered as a single D-region for design purposes. The maximum length-to-depth ratio of such a D-region would be approximately 2. Thus, the smallest angle between the strut and the tie in a D-region is $\arctan \frac{1}{2} = 26.5^\circ$, rounded to 25° .

When there is a B-region between the D-regions in a shear span, as shown in Figure 6.I.2(c), the strength of the shear span is governed by the strength of the B-region if the B- and D-regions have similar geometry and reinforcement, as because the shear strength of a B-region is less than the shear strength of a comparable D-region. Shear spans containing B-regions-the usual case in beam design-are designed for shear using the traditional shear design procedures from Sections 6.4.1 to 6.4.4 ignoring D-regions.

Deep Beam: See Sections 6.3.7.1 and 6.4.6.1.

Clarification for Deep Beam: See Figures 6.I.2(a), 6.I.2(b), and 6.I.3, and Sections 6.3.7 and 6.4.6.

Nodal Zone: The volume of concrete around a node assumed to transfer strut-and-tie forces through the node.

Clarification for Nodal Zone: Hydrostatic nodal zones as shown in Figure 6.I.4 were used traditionally. These were largely superseded by what are called extended nodal zones, shown in Figure 6.I.5.

A hydrostatic nodal zone has equal stresses on the loaded faces which are perpendicular to the axes of the struts and ties acting on the node. A C-C-C nodal zone is shown in Figure 6.I.4(a). If the stresses on the face of the nodal zone are the same in all three struts, the ratios of the lengths of the sides of the nodal zone, $w_{n1} : w_{n2} : w_{n3}$ are in the same proportions as the three forces $C_1 : C_2 : C_3$. The faces of a hydrostatic nodal zone are perpendicular to the axes of the struts and ties acting on the nodal zone.

As the in-plane stresses are the same in all directions, these nodal zones are called hydrostatic nodal zones. This terminology, strictly speaking, is incorrect because the in-plane stresses are not equal to the out-of-plane stresses.

A C-C-T nodal zone can be represented as a hydrostatic nodal zone if the tie is assumed to extend through the node to be anchored by a plate on the far side of the node, as shown in Figure 6.I.4(b), provided that the size of the plate results in bearing stresses that are equal to the stresses in the struts. The bearing plate on the left side of Figure 6.I.4(b) is used to represent an actual tie anchorage. The tie force can be anchored by a plate, or through development of straight or hooked bars, as shown in Figure 6.I.4(c).

Portion of a member bounded by the intersection of the effective strut width, w_s , and the effective tie width, w_t (see Sec I.4.2) is an extended nodal zone. The shaded areas in Figures 6.I.5(a) and (b) are extended nodal zones.

The reaction R equilibrates the vertical components of the forces C_1 and C_2 in the nodal zone shown in Figure 6.I.6(a). Frequently, calculations are easier if the reaction R is divided into R_1 , which equilibrates the vertical component of C_1 and R_2 , which equilibrates the vertical component of the force C_2 , as shown in Figure 6.I.6(b).

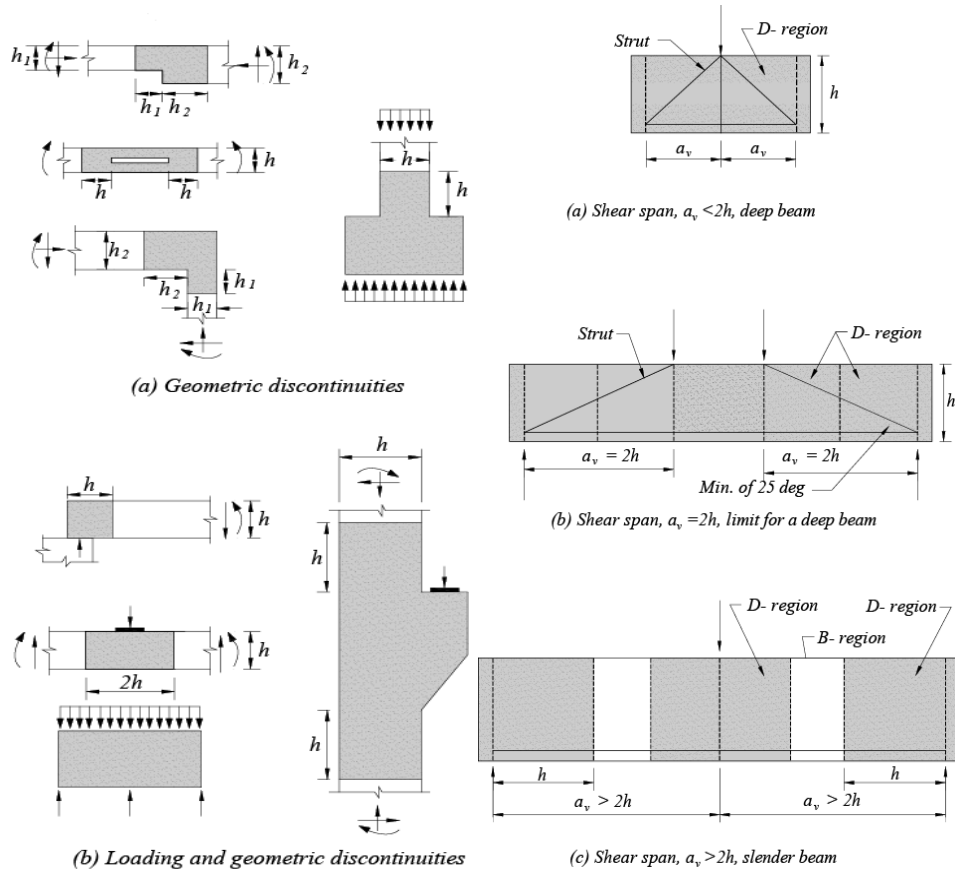


Figure 6.1.1 D-Regions and discontinuities

Figure 6.1.2 Description of deep and slender beams

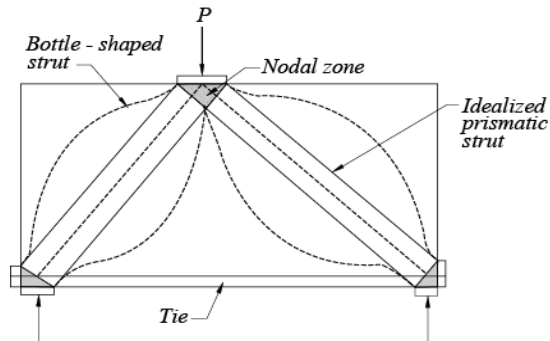


Figure 6.1.3 Description of strut-and-tie model

Note: The point in a joint in a strut-and-tie model where the axes of the struts, ties, and concentrated forces acting on the joint intersect.

Clarification for Node: To be in equilibrium, at least three forces should act on a node in a strut-and-tie model, as shown in Figure 6.I.7. Classification of nodes is based on signs of these forces. A C-C-C node resists three compressive forces, a C-C-T node resists two compressive forces and one tensile force, and so on.

Strut: A member that is in compression in a strut-and-tie model. A strut represents the resultant of a parallel or a fan-shaped compression field.

Clarification for Strut: Struts are usually idealized in design as prismatic compression members, as shown by the straight line outlines of the struts in Figures 6.I.2 and 6.I.3. The strut is idealized as a uniformly tapered compression member, if the effective compression strength f_{ce} differs at the two ends of a strut, due either to different nodal zone strengths at the two ends, or to different bearing lengths.

Bottle-shaped Strut: A strut that is wider at mid-length than at its ends.

Clarification for Bottle-shaped Struts: A strut located in a part of a member where the width of the compressed concrete at mid-length of the strut can spread laterally is a bottle-shaped strut. The curved dashed outlines of the struts in Figure 6.I.3 and the curved solid outlines in Figure 6.I.8 approximate the boundaries of bottle-shaped struts. A split cylinder test is an example of a bottle-shaped strut. The internal lateral spread of the applied compression force in such a test leads to a transverse tension that splits the specimen.

Bottle-shaped struts are idealized either as prismatic or as uniformly tapered in design, and crack-control reinforcement from Sec I.3.3 is provided to resist the transverse tension. The amount of confining transverse reinforcement can be computed using the strut-and-tie model shown in Figure 6.I.8(b) with the struts that represent the spread of the compression force acting at a slope of 1:2 to the axis of the applied compressive force. Alternatively for f_c' not exceeding 40 MPa, Eq. (I.4) can be used. The cross-sectional area A_c of a bottle-shaped strut is taken as the smaller of the cross-sectional areas at the two ends of the strut. See Figure 6.I.8(a).

Strut-and-tie Model: A truss model of a structural member, or of a D-region in such a member, made up of struts and ties connected at nodes, capable of transferring the factored loads to the supports or to adjacent B-regions.

Clarification for Strut-and-tie Model: In Figure 6.I.3, the components of a strut-and-tie model of a single-span deep beam loaded with a concentrated load are identified. The thickness and width, both perpendicular to the axis of the strut or tie are designated as the cross-sectional dimensions of a strut or tie. Thickness is perpendicular to the plane of the truss model, and width is in the plane of the truss model.

Tie: A member that is in tension in a strut-and-tie model.

Clarification for Tie: A tie is a member consisting of reinforcement or pre-stressing steel plus a portion of the surrounding concrete that is concentric with the axis of the tie. The surrounding concrete is included to define the zone in which the forces in the struts and ties are to be anchored. The concrete in a tie is not used to resist the axial force in the tie. Although not considered in design, the surrounding concrete will reduce the elongations of the tie, especially at service loads.

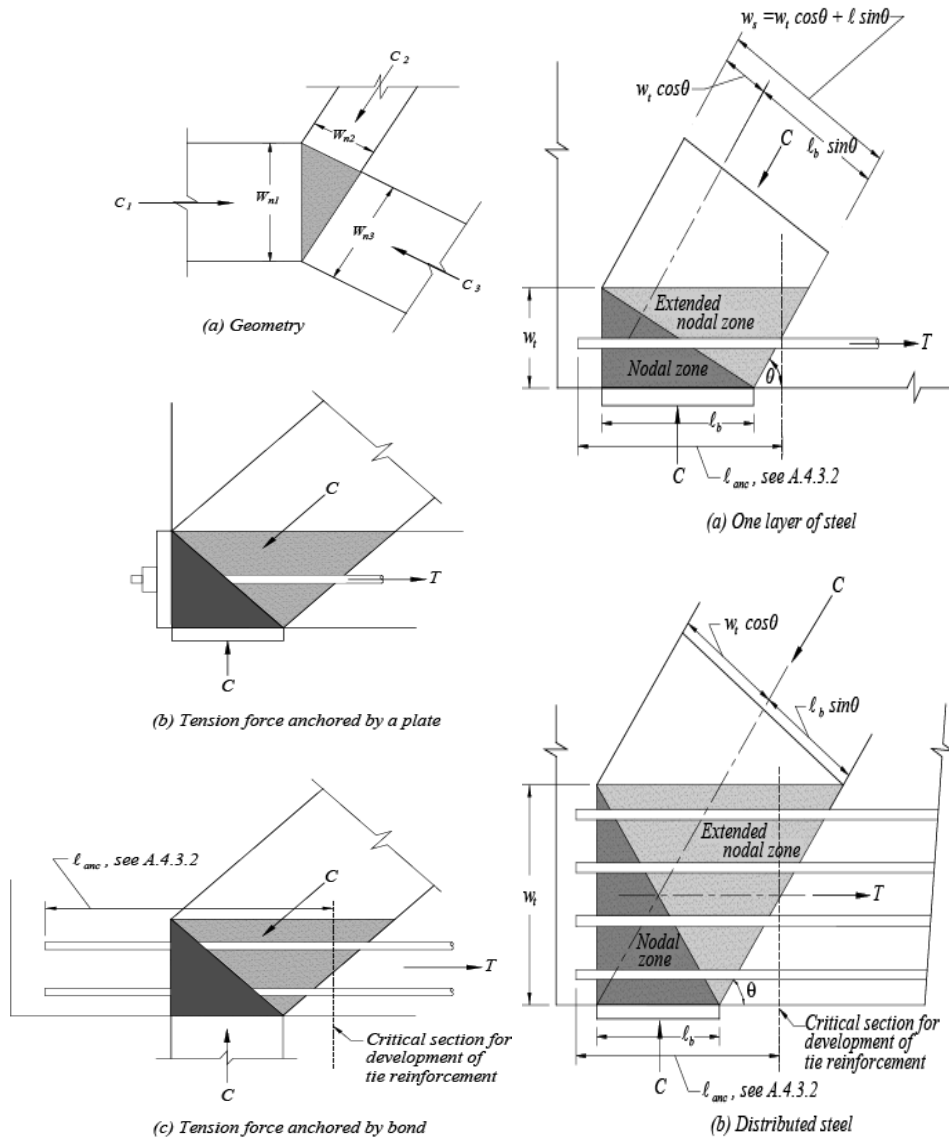


Figure 6.I.4 Hydrostatic nodes

Figure 6.I.5 Extended nodal zone showing the effect of the distribution of the force

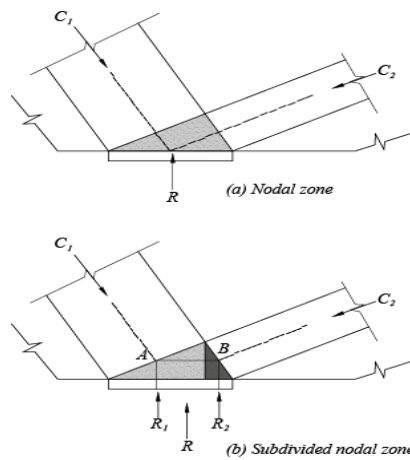


Figure 6.I.6 Subdivision of nodal zone

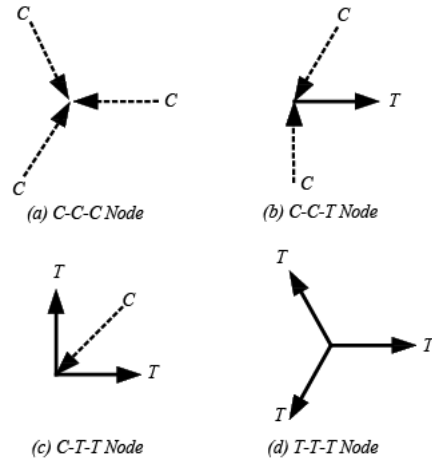


Figure 6.I.7 Classification of nodes

I.2 Design Procedure for Strut-and-Tie Model

I.2.1 It shall be allowed to design structural concrete members, or D-regions in such members, by modeling the member or region as an idealized truss. The truss model shall contain struts, ties, and nodes as defined in Sec I.1. The truss model shall be capable of transferring all factored loads to the supports or adjacent B-regions.

Clarification for Section I.2.1: The truss model described in Sec I.2.1 is what is referred to as a strut-and-tie model. Details of the use of strut-and-tie models are available in References I.1 to I.7 of Sec I.6. The design of a D-region includes the following four steps:

- (a) First, define and isolate each D-region;
- (b) Then, compute resultant forces on each D-region boundary;
- (c) Then, a truss model is to be selected to transfer the resultant forces across the D-region. The axes of the struts and ties, respectively, are chosen to approximately coincide with the axes of the compression and tension fields. The forces in the struts and ties are computed.
- (d) Finally, the effective widths of the struts and nodal zones are determined considering the forces from Step 3 and the effective concrete strengths defined in Sections I.3.2 and I.5.2, and reinforcement is provided for the ties considering the steel strengths defined in Sec I.4.1. The reinforcement should be anchored in the nodal zones.

Code requirements for serviceability should be satisfied for strut-and-tie models representing strength limit states. Deflections of deep beams or similar members can be estimated using an elastic analysis to analyze the strut-and-tie model. In addition, the crack widths in a tie can be controlled using Sec 6.3.6.4, assuming the tie is encased in a prism of concrete corresponding to the area of tie from Sec I.4.2.

I.2.2 Under the applied loads and the reactions, the strut-and-tie model shall be in equilibrium.

I.2.3 The dimensions of the struts, ties, and nodal zones shall be taken into account in determining the geometry of the truss,

Clarification for Section I.2.3: The components of the strut-and-tie model, i.e. the struts, ties, and nodal zones, all have finite widths that should be taken into account in selecting the dimensions of the truss. Figure 6.I.9(a) shows a node and the corresponding nodal zone. The vertical and horizontal forces equilibrate the force in the inclined strut. If the stresses are equal in all three struts, a hydrostatic nodal zone can be used and the widths of the struts will be in proportion to the forces in the struts.

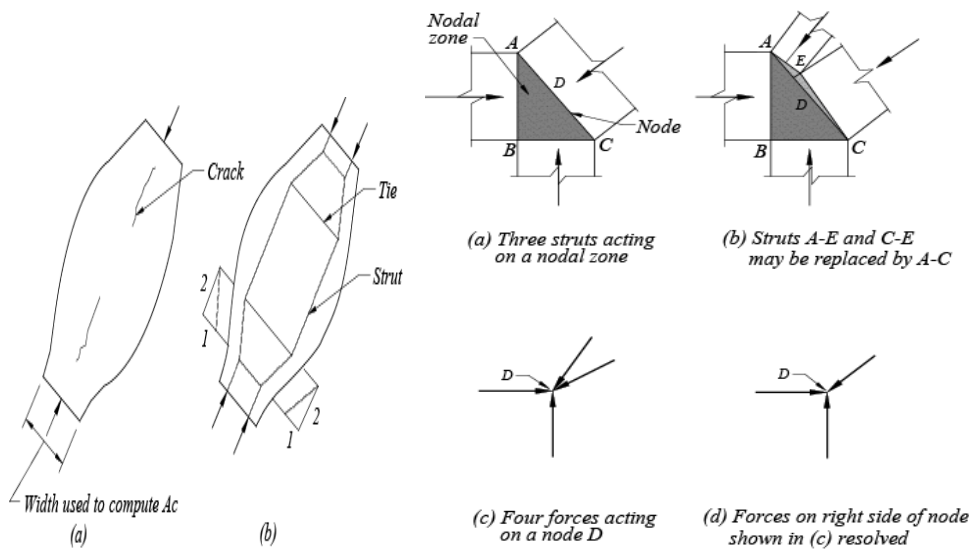


Figure 6.I.8 Bottle-shaped strut: (a) cracking of a bottle-shaped strut; and (b) strut-and-tie model of a bottle-shaped strut

Figure 6.I.9 Resolution of forces on a nodal zone

When more than three forces act on a nodal zone in a two-dimensional structure, as shown in Figure 6.I.9(b), it is generally necessary to resolve some of the forces to end up with three intersecting forces. The strut forces acting on Faces A-E and C-E in Figure 6.I.9(b) can be replaced with one force acting on Face A-C. This force passes through the node at D.

Alternatively, the strut-and-tie model could be analyzed assuming all the strut forces acted through the node at D, as shown in Figure 6.I.9(c). In this case, the forces in the two struts on the right side of Node D can be resolved into a single force acting through Point D, as shown in Figure 6.I.9(d).

Transverse reinforcement may be required to restrain vertical splitting in the plane of the node when the width of the support in the direction perpendicular to the member is less than the width of the member. This can be modeled using a transverse strut-and-tie model.

I.2.4 Ties shall be permitted to cross struts. Struts shall cross or overlap only at nodes.

I.2.5 The angle, θ , between the axes of any strut and any tie entering a single node shall not be taken as less than 25° .

Clarification for Section I.2.5: In order to mitigate cracking and to avoid incompatibilities due to shortening of the struts and lengthening of the ties occurring in almost the same directions, the angle between the axes of struts and ties acting on a node should be large enough. This limitation on the angle prevents modeling the shear spans in slender beams using struts inclined at less than 25° from the longitudinal steel (Reference I.6 of Sec I.6).

I.2.6 Struts, ties, and nodal zones shall be designed based on

$$\phi F_n \geq F_u \quad (6.1.1)$$

Where, F_u is the factored force acting in a strut, in a tie, or on one face of a nodal zone; F_n is the nominal strength of the strut, tie, or nodal zone; and ϕ is specified in Sec 6.2.3.2.6.

Clarification for Section I.2.6: The forces in all the struts, ties, and nodal zones are computed after applying factored loads to the strut-and-tie model. If several loading cases exist, each should be investigated. The strut-and-tie model, or models, are analyzed for the loading cases and, for a given strut, tie, or nodal zone, F_u is the largest force in that element for all loading cases.

I.3 Strength of Struts

I.3.1 For a strut without longitudinal reinforcement, the nominal compressive strength, F_{ns} , shall be taken as the smaller value of

$$F_{ns} = f_{ce} A_{cs} \quad (6.1.2)$$

at the two ends of the strut, where A_{cs} is the cross-sectional area at one end of the strut, and f_{ce} is the smaller of (a) and (b):

- (a) the effective compressive strength of the concrete in the strut given in Sec I.3.2;
- (b) the effective compressive strength of the concrete in the nodal zone given in Sec I.5.2.

Clarification for Section I.3.1: The smaller dimension perpendicular to the axis of the strut at the ends of the strut is taken as the width of strut w_s used to compute A_{cs} . This strut width is illustrated in Figures 6.I.4(a), 6.I.5(a) and 6.I.5(b). The thickness of the struts may be taken as the width of the member in two-dimensional structures, such as deep beams.

I.3.2 The effective compressive strength of the concrete, f_{ce} , in a strut shall be taken as

$$f_{ce} = 0.85\beta_s f'_c \quad (6.I.3)$$

Clarification for Section I.3.2: The strength coefficient, $0.85f'_c$, in Eq. 6.I.3 represents the effective concrete strength under sustained compression, similar to that used in Equations 6.6.8 and 6.6.9.

I.3.2.1 When a strut has uniform cross-sectional area over its length, $\beta_s = 1.0$

Clarification for Section I.3.2.1: The value of β_s in Sec I.3.2.1 applies to a strut equivalent to the rectangular stress block in a compression zone in a beam or column.

I.3.2.2 For struts located such that the width of the midsection of the strut is larger than the width at the nodes (bottle-shaped struts):

- (a) With reinforcement satisfying Sec I.3.3, $\beta_s = 0.75$
- (b) Without reinforcement satisfying Sec I.3.3, $\beta_s = 0.60\lambda$

Where the value of λ is defined in Sec 6.1.8.1.

Clarification for Section I.3.2.2: The value of β_s given in Sec I.3.2.2 applies to bottle-shaped struts as shown in Figure 6.I.3. The internal lateral spread of the compression forces can lead to splitting parallel to the axis of the strut near the ends of the strut, as shown in Figure 6.I.8. Reinforcement placed to resist the splitting force restrains crack width, allows the strut to resist more axial load, and permits some redistribution of force.

The value given for β_s in Sec I.3.2.2(b) includes the correction factor, λ , for lightweight concrete because the strength of a strut without transverse reinforcement is assumed to be limited to less than the load at which longitudinal cracking develops.

I.3.2.3 For struts in tension members, or the tension flanges of members, $\beta_s = 0.40$

Clarification for Section I.3.2.3: The value given for β_s in Sec I.3.2.3 applies, for example, to compression struts in a strut-and-tie model used to design the longitudinal and transverse reinforcement of the tension flanges of beams, box girders, and walls. The low value of β_s reflects that these struts need to transfer compression across cracks in a tension zone.

I.3.2.4 For all other cases, $\beta_s = 0.60\lambda$

Clarification for Section I.3.2.4: The value given for β_s in Sec I.3.2.4 applies to strut applications not included in Sections I.3.2.1, I.3.2.2, and I.3.2.3. Examples are struts in a beam web compression field in the web of a beam where parallel diagonal cracks are likely to divide the web into inclined struts, and struts are likely to be crossed by cracks at an angle to the struts [see Figures 6.I.10(a) and (b)]. Sec I.3.2.4 gives a reasonable lower limit on β_s except for struts described in Sections I.3.2.2(b) and I.3.2.3.

I.3.3 If the specified value of β_s in Sec I.3.2.2(a) is used, the axis of the strut shall be crossed by reinforcement proportioned to resist the transverse tensile force resulting from the compression force spreading in the strut. It shall be permitted to assume the compressive force in the strut spreads at a slope of 2 longitudinal to 1 transverse to the axis of the strut.

Clarification for Section I.3.3: The reinforcement necessary from Sec I.3.3 is related to the tension force in the concrete due to the spreading of the strut, as shown in the strut-and-tie model in Figure 6.I.8(b). Sec I.3.3 allows the use of local strut-and-tie models to compute the amount of transverse reinforcement needed in a given strut. The compressive forces in the strut may be assumed to spread at a 2:1 slope, as shown in Figure 6.I.8(b). For specified concrete compressive strengths not exceeding 40 MPa, the amount of reinforcement required by Eq. 6.I.4 is deemed to satisfy Sec I.3.3.

Figure 6.I.11 shows two layers of reinforcement crossing a cracked strut. If the crack opens without shear slip along the crack, bars in layer i in the figure will cause a stress perpendicular to the strut of $\frac{A_{s_i} f_{s_i}}{b_s s_i} \sin \alpha_i$.

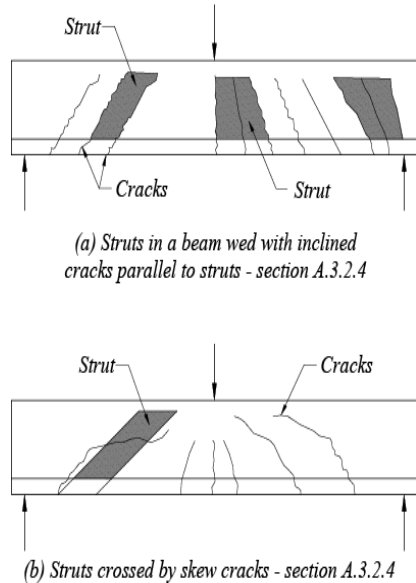


Figure 6.I.10 Types of struts

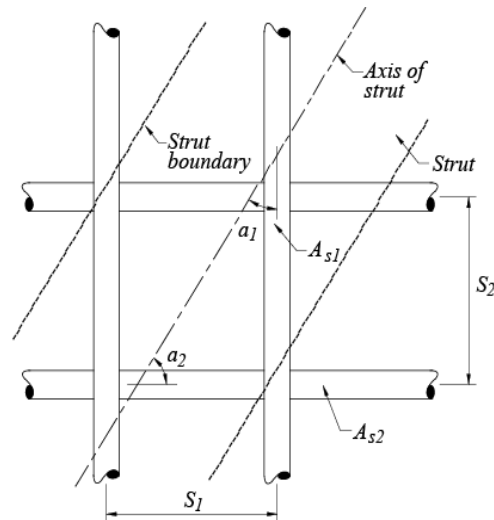


Figure 6.I.11 Reinforcement crossing a strut

Where the subscript i shall have the values of 1 and 2 for the vertical and horizontal bars, respectively, as shown in Figure 6.I.11. Eq. 6.I.4 is written in terms of a reinforcement ratio rather than a stress to simplify the calculation.

The confinement reinforcement given in Sec I.3.3 is difficult to place in three-dimensional structures (e.g. pile caps) most of the time. If this reinforcement is not provided, the value of f_{ce} given in Sec I.3.2.2(b) is used.

I.3.3.1 For f_c' not exceeding 40 MPa, the requirement of Sec I.3.3 shall be permitted to be satisfied by the axis of the strut being crossed by layers of reinforcement that satisfy Eq. 6.I.4.

$$\sum \frac{A_{si}}{b_s s_i} \sin \alpha_i \geq 0.003 \quad (6.I.4)$$

Where A_{si} is the total area of surface reinforcement at spacing s_i in the i -th layer of reinforcement crossing a strut at an angle α_i to the axis of the strut.

I.3.3.2 The reinforcement necessary in Sec I.3.3 shall be placed in either two orthogonal directions at angles α_1 and α_2 to the axis of the strut, or in one direction at an angle α to the axis of the strut. If the reinforcement is in one direction only, α shall not be less than 40° .

Clarification for Section I.3.3.2: The confinement reinforcement required to satisfy Sec I.3.3 is usually provided in the form of horizontal stirrups crossing the inclined compression strut in a corbel with a shear span-to-depth ratio less than 1.0, as shown in Figure 6.6.13 Chapter 6.

I.3.4 It shall be permitted to use an increased effective compressive strength of a strut due to confining reinforcement, if supported by tests and analyses.

Clarification for Section I.3.4: The design of tendon anchorage zones for pre-stressed concrete sometimes uses confinement to enhance the compressive strength of the struts in the local zone. Confinement of struts is discussed in References I.4 and I.8 of Sec I.6.

I.3.5 It shall be permitted to use compression reinforcement to increase the strength of a strut. Compression reinforcement shall be properly anchored, parallel to the axis of the strut, located within the strut, and enclosed in ties or spirals satisfying Sec 8.1.10 Chapter 8. In such cases, the nominal strength of a longitudinally reinforced strut is

$$F_{ns} = f_{ce} A_{cs} + A_s' f_s' \quad (6.I.5)$$

Clarification for I.3.5 - The last term in Eq. 6.I.5 gives the strength added by the reinforcement. The stress f_s' in the reinforcement in a strut at nominal strength can be obtained from the strains in the strut when the strut crushes. For Grade 40 or 60 reinforcement, f_s' can be taken as f_y .

I.4 Strength of Ties

I.4.1 The nominal strength of a tie, F_{nt} , shall be taken as

$$F_{nt} = A_{ts}f_y + A_{tp}(f_{se} + \Delta f_p) \quad (6.1.6)$$

Where $(f_{se} + \Delta f_p)$ shall not exceed f_{py} , and A_{tp} is zero for nonprestressed members.

In Eq. (I.6), it shall be permitted to take Δf_p equal to 420 MPa for bonded prestressed reinforcement, or 70 MPa for unbonded prestressed reinforcement. Other values of Δf_p shall be permitted when justified by analysis.

I.4.2 In the strut-and-tie model, the axis of the reinforcement in a tie shall coincide with the axis of the tie.

Clarification for Section I.4.2: The effective tie width w_t assumed in design can vary between the following limits, depending on the distribution of the tie reinforcement:

- If the bars in the tie are in one layer, the effective tie width can be taken as the diameter of the bars in the tie plus twice the cover to the surface of the bars, as shown in Figure 6.1.5(a); and
- A practical upper limit of the tie width can be taken as the width corresponding to the width in a hydrostatic nodal zone, calculated as

$$w_{t,max} = F_{nt}/(f_{ce}b_s)$$

Where f_{ce} is computed for the nodal zone in accordance with Sec I.5.2. If the tie width exceeds the value from (a), the tie reinforcement should be distributed approximately uniformly over the width and thickness of the tie, as shown in Figure 6.1.5(b).

I.4.3 Anchorage of tie reinforcement by mechanical devices, post-tensioning anchorage devices, standard hooks, or straight bar development as required by Sections I.4.3.1 to I.4.3.4 shall be ensured.

Clarification for Section I.4.3: Special attention is often required for anchorage of ties in nodal zones of corbels or in nodal zones adjacent to exterior supports of deep beams. The reinforcement in a tie should be anchored before it leaves the extended nodal zone at the point defined by the intersection of the centroid of the bars in the tie and the extensions of the outlines of either the strut or the bearing area. This length is l_{anc} . In Figure 6.1.5(a) and (b), this occurs where the outline of the extended nodal zone is crossed by the centroid of the reinforcement in the tie. Some of the anchorage may be achieved by extending the reinforcement through the nodal zone, as shown in Figure 6.1.4(c), and developing it beyond the nodal zone. If the tie is anchored using 90-degree

hooks, the hooks should be confined within the reinforcement extending into the beam from the supporting member to avoid cracking along the outside of the hooks in the support region.

In deep beams, hairpin bars spliced with the tie reinforcement can be used to anchor the tension tie forces at exterior supports, provided the beam width is large enough to accommodate such bars.

Figure 6.I.12 shows two ties anchored at a nodal zone. Development is required where the centroid of the tie crosses the outline of the extended nodal zone.

The development length of the tie reinforcement can be reduced through hooks, mechanical devices, additional confinement, or by splicing it with several layers of smaller bars.

I.4.3.1 Nodal zones shall develop the difference between the tie force on one side of the node and the tie force on the other side.

I.4.3.2 At nodal zones anchoring one tie, the tie force shall be developed at the point where the centroid of the reinforcement in a tie leaves the extended nodal zone and enters the span.

I.4.3.3 At nodal zones anchoring two or more ties, the tie force in each direction shall be developed at the point where the centroid of the reinforcement in the tie leaves the extended nodal zone.

I.4.3.4 The transverse reinforcement required by Sec I.3.3 shall be anchored in accordance with Sec 8.2.10 Chapter 8.

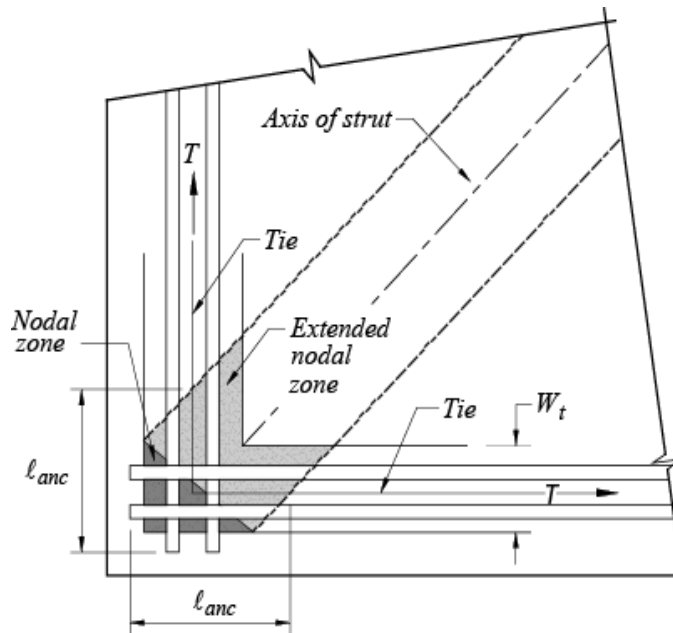


Figure 6.I.12 Extended nodal zone anchoring two ties

I.5 Strength of Nodal Zones

I.5.1 The Nominal compression strength of a nodal zone, F_{nn} , shall be

$$F_{nn} = f_{ce} A_{nz} \quad (6.1.7)$$

Where f_{ce} is the effective compressive strength of the concrete in the nodal zone as given in Sec I.5.2, and A_{nz} is the smaller of (a) and (b):

- (a) The area of the face of the nodal zone on which F_u acts, taken perpendicular to the line of action of F_u ;
- (b) The area of a section through the nodal zone, taken perpendicular to the line of action of the resultant force on the section.

Clarification for Section I.5.1: A hydrostatic nodal zone can be used, if the stresses in all the struts meeting at a node are equal. The faces of such a nodal zone are perpendicular to the axes of the struts, and the widths of the faces of the nodal zone are proportional to the forces in the struts.

Assuming the principal stresses in the struts and ties act parallel to the axes of the struts and ties, the stresses on faces perpendicular to these axes are principal stresses, and Sec I.5.1(a) is used. If, as shown in Figure 6.1.5(b), the face of a nodal zone is not perpendicular to the axis of the strut, there will be both shear stresses and normal stresses on the face of the nodal zone. Typically, these stresses are replaced by the normal (principal compression) stress acting on the cross-sectional area A_c of the strut, taken perpendicular to the axis of the strut as given in Sec I.5.1(a).

Sec I.5.1(b) requires in some cases that the stresses be checked on a section through a subdivided nodal zone. The stresses are checked on the least area section which is perpendicular to a resultant force in the nodal zone. In Figure 6.1.6(b), the vertical face which divide the nodal zone into two parts is stressed by the resultant force acting along A-B. The design of the nodal zone is governed by the critical section from Sec I.5.1(a) or Sec I.5.1(b), whichever gives the highest stress.

I.5.2 The calculated effective compressive stress, f_{ce} , on a face of a nodal zone due to the strut-and-tie forces shall not exceed the value given by

$$f_{ce} = 0.85 \beta_n f_c' \quad (6.1.8)$$

Unless confining reinforcement is provided within the nodal zone and its effect is supported by tests and analysis. The value of β_n for Eq. 6.1.8 is given in Sections I.5.2.1 to I.5.2.3.

I.5.2.1 In nodal zones bounded by struts or bearing areas, or both, $\beta_n = 1.0$

I.5.2.2 In nodal zones anchoring one tie, $\beta_n = 0.80$ or

I.5.2.3 $\beta_n = 0.80, \beta_n = 0.60$

Clarification for I.5.2 - In two-dimensional members, such as deep beams, the nodes can be classified as C-C-C if all the members intersecting at the node are in compression; as C-C-T nodes if one of the members acting on the node is in tension; and so on, as shown in Figure 6.I.7. The effective compressive strength of the nodal zone is given by Eq. 6.I.8, as modified by Section I.5.2.1 to I.5.2.3 apply to C-C-C nodes, C-C-T nodes, and C-T-T or T-T-T nodes, respectively.

The increasing degree of disruption of the nodal zones due to the incompatibility of tension strains in the ties and compression strains in the struts is reflected by the β_n values. The stress on any face of the nodal zone or on any section through the nodal zone should not exceed the value given by Eq. 6.I.8, as modified by Sections I.5.2.1 to I.5.2.3.

I.5.3 In a three-dimensional strut-and-tie model, the area of each face of a nodal zone shall not be less than that given in I.5.1, and the shape of each face of the nodal zones shall be similar to the shape of the projection of the end of the struts onto the corresponding faces of the nodal zones.

Clarification for Sections I.5.3: In order to simplify the calculations of the geometry of a three-dimensional strut-and-tie model, this description of the shape and orientation of the faces of the nodal zones is introduced.

I.6 Related References to Appendix I

I.1. Schlaich, J.; Schäfer, K.; and Jennewein, M., "Toward a Consistent Design of Structural Concrete," PCI Journal, V. 32, No. 3, May-June 1987, pp. 74-150.

I.2. Collins, M. P., and Mitchell, D., Prestressed Concrete Structures, Prentice Hall Inc., Englewood Cliffs, NJ, 1991, 766 pp.

I.3. MacGregor, J. G., Reinforced Concrete: Mechanics and Design, 3rd Edition., Prentice Hall, Englewood Cliffs, NJ, 1997, 939 pp.

I.4. FIP Recommendations, Practical Design of Structural Concrete, FIP-Commission 3, "Practical Design," Pub.: SETO, London, Sept. 1999.

I.5. Menn, C., Prestressed Concrete Bridges, Birkhäuser, Basle, 535 pp.

I.6. Muttoni, I.; Schwartz, J.; and Thürlimann, B., Design of Concrete Structures with Stress Fields, Birkhauser, Boston, MA, 1997, 143 pp.

I.7. Joint ACI-ASCE Committee 445, "Recent Approaches to Shear Design of Structural Concrete (ACI 445R-99)," American Concrete Institute, Farmington Hills, MI, 1999, 55 pp.

I.8. Bergmeister, K.; Breen, J. E.; and Jirsa, J. O., "Dimensioning of the Nodes and Development of Reinforcement," IABSE Colloquium Stuttgart 1991, International Association for Bridge and Structural Engineering, Zurich, 1991, pp. 551-556.

PART VI
Appendix J

Working Stress Design Method for Reinforced Concrete Structures

J.1 Analysis and Design - General Consideration

J.1.1 Notation

- A_s = Area of tension reinforcement
- A'_s = Area of compression reinforcement
- A_v = Area of shear reinforcement perpendicular to flexural tension reinforcement within a distance s , mm²
- A_{vh} = Area of shear reinforcement parallel to flexural tension reinforcement within a distance s_l , mm²
- E_c = Modulus of elasticity of concrete, N/mm²
- E_s = Modulus of elasticity of reinforcement, N/mm²
- H = Total lateral force acting in any storey
- M = Moment at the section acting simultaneously with P
- M_n = Flexural moment capacity
- M_r = Resisting moment capacity based on f'_c
- N = Axial load normal to cross section occurring simultaneously with V , to be taken as positive for compression, negative for tension and to include effects of tension due to creep and shrinkage
- P = Working axial load at the section
- R = Constant, $\frac{1}{2} f_c k j$
- T = Torsional moment at section
- T_c = Torsional moment strength provided by concrete
- T_s = Torsional moment strength provided by torsion reinforcement
- V = Shear at section
- V_c = Shear strength provided by concrete
- V_s = Shear strength provided by shear reinforcement
- V_n = Shear strength
- a = Shear span, distance between concentrated load and face of support, mm

- b = Width of rectangular beam, or effective width of compression flange for T-beam
- b_w = Web width, or diameter of circular section
- d, d' = Distance of extreme compression fibre to centroid of compression reinforcement
- d_c = Thickness of concrete cover measured from the extreme tension fibre to centre of bar or wire located closest thereto
- f_c = Allowable stress in concrete
- f'_c = Specified compressive strength of concrete, N/mm²
- f_s = Allowable/Permissible tensile stress in reinforcement, N/mm²
- f_y = Specified yield strength of reinforcement, N/mm²
- h = Overall thickness of members, mm.
- j, k = Beam constants defined in Sec J.2.6.1
- l = Effective span, mm
- l_n = Clear span measured face-to-face of supports, mm
- n = Modular ratio, E_s/E_c
- r = Stress ratio, f_s/f_c
- s = Spacing of shear or torsion reinforcement in direction parallel to longitudinal reinforcement, mm
- s_1 = Spacing of shear or torsion reinforcement in direction perpendicular to longitudinal reinforcement, mm
- t = Thickness of compression flange of T-beams
- v = Design shear stress, N/mm²
- v_c = Permissible shear stress carried by concrete, N/mm²
- z = lever arm used in Sec J.8.3
- β_c = Ratio of long side to short side of concentrated load or reaction area.
- Δ = Elastically computed first order lateral deflection due to H at the top of the storey relative to the bottom of the storey.
- ρ = Ratio of tension reinforcement, = A_s/bd
- ρ_w = $A_s/b_w d$

For all other symbols reference shall be made to Sec 6.1.1.

J.1.2 Design Methods

In the design of reinforced concrete structures using working stress design method, members shall be proportioned for adequate capacity in accordance with the provisions of this Chapter using working loads and permissible stresses. The working stress design method may be used as an alternative method with the requirement that provisions of Chapter 6, except Sec 6.1.5, shall apply to members designed by this method.

J.1.3 Design Assumptions

The design of reinforced concrete structures by the working stress design method is based on the following assumptions.

- J.1.3.1 At any cross section, plane sections before bending remain plane after bending; strains vary with the distance from the neutral axis.
- J.1.3.2 All tensile stresses are taken up by reinforcement and none by concrete, except otherwise specifically permitted.
- J.1.3.3 The stress-strain relation for concrete is a straight line under working loads within the allowable working stresses. Stresses vary linearly with the distance from the neutral axis except for deep beams.
- J.1.3.4 The tension reinforcement area is replaced in design computations with a concrete tension area equal to n times that of the reinforcement steel, where n is the modular ratio E_s/E_c .
- J.1.3.5 In doubly reinforced beams the compression reinforcement shall be transformed to an equivalent concrete area which is $2n$ times that of the reinforcement steel.
- J.1.3.6 The modular ratio $n = \frac{E_s}{E_c}$ may be taken as the nearest whole number, but not less than 6.
- J.1.3.7 The compressive stress developed in compression reinforcement of doubly reinforced beams shall not exceed the permissible tensile stress for such steel.

J.1.4 Loading

- J.1.4.1 Design provisions of this Chapter based on the assumption that structures shall be designed to resist all applicable loads.
- J.1.4.2 Service loads shall be in accordance with Chapter 2, Loads, with such live load reductions as are permitted therein.

- J.1.4.3 In the design for wind and earthquake loads, integral structural parts shall be designed to resist the total lateral loads.
- J.1.4.4 Consideration shall be given to effects of forces due to crane loads, vibration, impact, shrinkage, temperature changes, creep and unequal settlement of supports.
- J.1.4.5 When dead load reduces effects of other loads, members shall be designed for 85 percent of the dead load in combination with the other loads.

J.1.5 Stiffness

- J.1.5.1 Use of any consistent set of assumptions is permitted for computing relative flexural and torsional stiffness of columns, walls, floors, and roof systems.
- J.1.5.2 In computing the value of I for relative flexural stiffness of slabs, beams, girders, and columns, contribution of the reinforcement may be neglected. In T-shaped sections allowance shall be made for the effect of flange.
- J.1.5.3 If the total torsional stiffness in the plane of a continuous system at a joint does not exceed 20 percent of the flexural stiffness at the joint, the torsional stiffness need not be taken into consideration in the analysis.
- J.1.5.4 Effect of haunches shall be considered both in determining the moments and in the design of members.

J.1.6 Span Length

- J.1.6.1 Span length of members not built integrally with supports shall be considered as the clear span plus depth of member but need not to exceed distance between centres of supports.
- J.1.6.2 In determining moments in frames or continuous construction, span lengths shall be taken as the centre-to-centre distance of supports.
- J.1.6.3 For design of beams built integrally with supports, the use of moments at faces of support is permitted.
- J.1.6.4 Solid or ribbed slabs built integrally with supports, with clear span not more than 3.0 m, are permitted to be analysed as continuous slabs on knife edge supports, with spans equal to the clear spans of the slab, the width of beams being otherwise neglected.
- J.1.6.5 Effective span of cantilevered beams or slabs shall be taken as its span to the face of support plus half its effective depth, except where it is an overhang of a continuous beam, the length to the centre of the support shall be used.

J.1.7 Arrangement of Live Loads

For continuous beams and frames the arrangement of live load may be limited to the combination of:

- (a) Service dead load on all spans with full service live load on two adjacent spans, and
- (b) Service dead load on all spans with full service live load on alternate spans.

J.1.8 Floor Finish

J.1.8.1 A floor finish shall not be included as part of a structural member unless placed monolithically with the floor slab or designed in accordance with requirements of composite concrete flexural members.

J.1.8.2 It is allowed to consider all concrete floor finishes as part of required cover or total thickness for non-structural considerations.

J.1.9 Allowable Stresses in Concrete

Allowable stresses in concrete shall not exceed the following:

- (a) Flexure:

Extreme fibre stress in compression $0.45 f'_c$

- (b) Shear:

Beams, one-way slabs and footings :

Shear stress carried by concrete, v_c $0.091\sqrt{f'_c}$

Maximum shear stress carried by concrete plus shear reinforcement $0.457\sqrt{f'_c}$

Ribs: $0.10\sqrt{f'_c}$

Shear stress carried by concrete, v_c

Two-way slabs and footings : $(0.083 + 0.17/\beta_c)\sqrt{f'_c} \leq 0.17\sqrt{f'_c}$

Shear stress carried by concrete, v_c

- (c) Bearing stress on loaded area :

When the loaded area (area of column, pier or base plate) and the supporting area (area of the top of footing) are equal $0.3\sqrt{f'_c}$

When the supporting area is larger than the loaded area on all sides $0.3\sqrt{\left(\frac{A_1}{A_2}\right)}f'_c \leq 0.6f'_c$

Where,

A_1 = Area of the lower base of the largest frustum of a pyramid, cone, or tapered wedge contained wholly within the footing and having for its upper base, the area actually loaded, and having side slopes of 1 vertical to 2 horizontal, and

A_2 = Loaded area of the column base.

J.1.10 Allowable Stresses in Reinforcement

Allowable tensile stresses in reinforcement f_s , shall be those as specified below:

(a) Except as specified in (b) below, f_s shall be determined as follows :

(i) For $250\text{N/mm}^2 \leq f_y < 275\text{N/mm}^2$: $f_s = 125\text{ N/mm}^2$

(ii) For $275\text{N/mm}^2 \leq f_y < 420\text{N/mm}^2$: $f_s = 138\text{ N/mm}^2$

(iii) For $f_y \geq 420\text{N/mm}^2$: $f_s = 165\text{ N/mm}^2$

(b) For flexural reinforcement, 100 mm or less in diameter in one-way slabs of not more than 3.5 m span: $f_s = 0.5f_y$ but not greater than 200 N/mm^2

J.1.11 Allowable Stresses for Wind and Earthquake Forces

Members subject to stresses produced by wind or earthquake forces combined with other loads may be proportioned for stresses 33 percent greater than those specified in Sections J.1.9 and J.1.10, provided that the section thus required is not less than that required for the combination of dead and live load.

J.1.12 Development and Splices of Reinforcement

J.1.12.1 Development and splices of reinforcement shall be in accordance with Chapter 8, Detailing of Reinforcement in Concrete Structures.

J.1.12.2 In satisfying requirements of Sec 8.2.8.3, M_n shall be taken as computed moment capacity assuming all positive moment tension reinforcement at the section to be stressed to the permissible tensile stress f_s and V_u shall be taken as unfactored shear force at the section.

J.2 Beams and One-Way Slabs

J.2.1 Notation

All the notation used this Section are provided in Sec. J.1.1

J.2.2 Span Length

Determination of span length shall be in accordance with Sec J.1.6.

J.2.3 Design Assumptions

Design assumptions shall be in accordance with Sec J.1.3.

J.2.4 General Principles and Requirements

- J.2.4.1 Design of cross section subject to flexural or combined flexure and axial loads shall be based on design assumptions of Sec J.1.3.
- J.2.4.2 Compression reinforcement in conjunction with additional tension reinforcement may be used to increase flexural strength of the members.
- J.2.4.3 The effective depth, d , of a beam or slab shall be taken as the distance from the centroid of its tensile reinforcement to its compression face.
- J.2.4.4 The effects of lateral eccentricity of load shall be taken into account in determining the spacing of lateral supports for a beam. The spacing shall never exceed 50 times the least width b of compression flange or face.
- J.2.4.5 Requirements of T-beams
- (a) In T-beam construction the slab and beam shall be built integrally or otherwise effectively bonded together.
 - (b) The effective flange width to be used in the design of symmetrical T-beams shall not exceed one-fourth of the span length of the beam, and its overhanging width on either side of the web shall not exceed eight times the thickness of the slab nor one-half the clear distance to the next beam.
 - (c) Isolated beams in which the T-form is used only for the purpose of providing additional compression area, shall have a flange thickness not less than one-half the width of the web and a total flange width not more than four times the width of the web.
 - (d) For beams having a flange on one side only, the effective overhanging flange width shall not exceed $\frac{1}{12}$ th of the span length of the beam, nor six times the thickness of the slab, nor one-half the clear distance to the next web.

- (e) The overhanging portion of the flange of the beam shall not be considered effective in computing the shear and diagonal tension resistance of T-beams.
- (f) Provision shall be made for the compressive stress at the support in continuous T-beam construction.

J.2.5 Continuous Beams

Continuous beams shall be analysed in accordance with Sec J.2.5.2 and designed and detailed according to Sec J.2.6 and J.2.7 to resist moments and shear forces.

J.2.5.1 Arrangement of Live Loads: Arrangement of live loads shall be in accordance with Sec J.1.7.

J.2.5.2 Methods of analysis

- (a) All members of frames or continuous construction shall be designed for the maximum effects of working loads as determined by the theory of elastic analysis.
- (b) In lieu of exact analysis, the approximate moments and shears given in Sec 6.1.4.3 may be used for design of continuous beams and one way slabs (slab reinforced to resist flexural stresses in only one direction), provided that the quantity w_u in the expressions in Sec. 6.1.4.3 is replaced by the working load w .
- (c) No redistribution of negative moment shall be permitted for working stress design.

J.2.6 Design for Flexure

J.2.6.1 The following equations are applicable to singly and doubly reinforced rectangular beams :

When, the stress ratio, r is known

$$k = \frac{n}{n + r} \quad (6.J.1)$$

When, steel ratio, ρ is known

$$k = \sqrt{2n\rho + (n\rho)^2} - n\rho \quad (6.J.2)$$

$$j = 1 - k/3 \quad (6.J.3)$$

$$R = \frac{1}{2} f_c k j \quad (6.J.4)$$

$$M_r = R b d^2 \quad (6.J.5)$$

J.2.6.2 Formulae for Singly Reinforced Rectangular Beams: If external bending moment M is less than resisting moment M_r , the area of tensile reinforcement shall be calculated using the following formula :

$$A_s = \frac{M}{f_s j d} \quad (6.J.6)$$

J.2.6.3 Formulae for Doubly Reinforced Beams : If $M > M_r$ the beam shall be designed for tensile and compressive reinforcements using the following formulae :

$$A'_s = \frac{M - M_r}{f'_s (d - d')} \quad (6.J.7)$$

Where,

$$f'_s = \frac{2n-1}{n} \left(\frac{k - d'/d}{1-k} \right) f_s \leq f_s \quad (6.J.8)$$

$$A_s = \frac{M_r}{f_s j d} + \frac{(M - M_r)}{f_s (d - d')} \quad (6.J.9)$$

J.2.6.4 Design of T-beams: A T-beam, where the flange is on the compression side, shall be treated as a rectangular beam if $M \leq \frac{1}{2} f_c b t (d - t/3)$. Otherwise, the beam shall be considered as a T-beam, in which case the following formulae shall be applicable :

$$k = \frac{n\rho + \frac{1}{2}(t/d)^2}{n\rho + (t/d)} \quad (6.J.10)$$

Where,

$$\rho = A_s / b d$$

$$j = 1 - \left[\frac{3k - 2(t/d)}{2k - (t/d)} \right] (t/d) \quad (6.J.11)$$

$$A_s = \frac{M}{f_s j d} \quad (6.J.6)$$

Actual stress in concrete, f_{ca} can be obtained from the relation:

$$f_{ca} = \frac{M}{(1 - t/2kd) b j d} \quad (6.J.12)$$

While using Eq. 6.J.10, if ρ is not known, it may be initially estimated as $\rho = M / [(d - t/2) b d f_s]$

J.2.7 Shear and Torsion

J.2.7.1 The design shear force V shall not exceed the sum of the shear strength provided by concrete, V_c and that provided by shear reinforcement, V_s .

$$V \leq V_c + V_s \quad (6.J.13)$$

J.2.7.2 When the reaction, in the direction of applied shear, introduces compression into the end regions of a member, sections located less than a distance d from face of support may be designed for the same shear force V as that computed at a distance d .

J.2.7.3 Shear strength provided by concrete

- (a) For members subject to shear and flexure, shear strength provided by concrete, V_c shall not exceed $0.091\sqrt{f'_c}b_wd$ unless a more detailed calculation is made in accordance with (d) below.
- (b) For members subject to shear and axial compression, shear strength provided by concrete V_c shall not exceed $0.091\sqrt{f'_c}b_wd$ unless a more detailed calculation is made in accordance with (e) below.
- (c) For members subject to significant axial tension, shear reinforcement shall be designed to carry total shear, unless a more detailed calculation is made using

$$V_c = 0.091 \left(1 + 0.58 \frac{N}{A_g} \right) \sqrt{f'_c} b_w d \quad (6.J.14)$$

Where, N is design axial load normal to cross-section occurring simultaneously with V and is negative for tension.

(d) For members subject to shear and flexure only, V_c may be computed by :

$$V_c = \left(0.083\sqrt{f'_c} + 9\rho_w \frac{Vd}{M} \right) b_w d \leq 0.16\sqrt{f'_c} b_w d \quad (6.J.15)$$

Quantity Vd/M shall not be taken greater than 1.0, where M is design moment occurring simultaneously with V at section considered, and $\rho_w = A_s/b_wd$.

(e) For members subject to axial compression, V_c may be computed by :

$$V_c = 0.091 \left(1 + 0.09 \frac{N}{A_g} \right) \sqrt{f'_c} b_w d \quad (6.J.16)$$

- (f) For members subjected to torsional moment T exceeding $(0.023\sqrt{f'_c})\sum x^2y$, V_c may be computed by

$$V_c = \frac{0.091\sqrt{f'_c}b_wd}{\sqrt{1+(2.5C_t T/V)^2}} \quad (6.J.17)$$

For calculation of $\sum x^2y$, the following conditions shall apply:

- (i) For members with rectangular or flanged sections, the sum $\sum x^2y$ shall be taken for the component rectangles of the section, but the overhanging flange-width used in design shall not exceed three times the flange thickness.
- (ii) A rectangular box section shall be taken as solid section provided the wall thickness h is at least $x/4$. A box section with wall thickness less than $x/4$ but greater than $x/10$ shall be taken as solid section except that $\sum x^2y$ shall be multiplied by $4h/x$. When h is less than $x/10$, the stiffness of the wall shall be considered. Fillets shall be provided at interior corners of box sections.
- (g) In determining shear strength provided by concrete V_c , whenever applicable, effects of axial tension due to creep and shrinkage in restrained members shall be considered and effects of inclined flexural compression in variable-depth members may be included.

J.2.7.4 Shear strength provided by shear reinforcement

- (a) Types of shear reinforcement

Shear reinforcement may consist of:

- (i) stirrups perpendicular to axis of member,
- (ii) bent up longitudinal reinforcement with bent portion making an angle of 30° or more with longitudinal tension reinforcement,
- (iii) combination of stirrups and bent longitudinal reinforcement,
- (iv) spirals.

- (b) Design yield strength of shear reinforcement shall not exceed 420 N/mm^2 .
- (c) Stirrups shall extend to a distance d from extreme compression fibre and shall be anchored at both ends in accordance with Sec 8.2.

(d) Spacing limits for shear reinforcement

- (i) Spacing of shear reinforcement perpendicular to member axis shall not exceed $d/2$, nor 600 mm.
- (ii) Bent longitudinal bars shall have a maximum spacing of $0.375d (1 + \cot\alpha)$, but not greater than 600 mm, where, α is the acute angle between the bent bar and the horizontal.
- (iii) When $(V - V_c)$ exceeds $0.17\sqrt{f'_c}b_wd$ maximum spacing given in (i) and (ii) above shall be reduced by one-half.

(e) Minimum shear reinforcement

- (i) A minimum area of shear reinforcement shall be provided in all reinforced concrete flexural members where design shear force V is greater than one-half the permissible shear strength V_c provided by concrete, except slabs, footings, ribbed construction and beams with total depth not exceeding the largest of 2.5 times thickness of flange, one-half the width of web, and 250 mm.
- (ii) Where shear reinforcement is required by (i) above or by analysis, minimum area of shear reinforcement shall be computed by

$$A_v = 0.35 \frac{b_w s}{f_y} \quad (6.J.18)$$

- (iii) Where torsional moment T exceeds $(0.023\sqrt{f'_c})\sum x^2y$ and where web reinforcement is required by (i) above or by analysis, the minimum area of closed stirrups shall be computed by

$$A_v + 2A_t = 0.35 \frac{b_w s}{f_y} \quad (6.J.19)$$

Where, A_t is the area of one leg of closed stirrup.

(f) Design of Shear Reinforcement

- (i) Where design shear force V exceeds shear strength provided by concrete V_c , shear reinforcement shall be provided in accordance with (ii) to (viii) below.
- (ii) When shear reinforcement perpendicular to axis of member is used,

$$A_v = \frac{(V - V_c) s}{f_s d} \quad (6.J.20)$$

- (iii) When inclined stirrups are used as shear reinforcement,

$$A_v = \frac{(V - V_c) s}{f_s d (\sin\alpha + \cos\alpha)} \quad (6.J.21)$$

- (iv) When shear reinforcement consists of a single bar or a single group of parallel bars, all bent up at the same distance from the support,

$$A_v = \frac{(V - V_c) s}{f_s d \sin \alpha} \quad (6.J.22)$$

Where $(V - V_c)$ shall not exceed $0.133\sqrt{f'_c}b_w d$

- (v) When shear reinforcement consists of a series of parallel bent-up bars or groups of parallel bent-up bars at different distances from the support, required area shall be computed by Eq. 6.J.21.
- (vi) Only the centre three-quarters of the inclined portion of any longitudinal bent bar shall be considered effective for shear reinforcement.
- (vii) When more than one type of shear reinforcement is used to reinforce the same portion of member, required area shall be computed as the sum of the various types separately. In such computations, V_c shall be included only once.
- (viii) Value of $(V - V_c)$ shall not exceed $0.365\sqrt{f'_c}b_w d$

J.2.7.5 Combined shear and torsion

- (a) Torsion effects shall be included with shear and flexure where torsional moment T exceeds $(0.023\sqrt{f'_c})\sum x^2 y$. Otherwise, torsion may be neglected. For calculation of $\sum x^2 y$, see Sec J.2.7.3(f).
- (b) If torsional moment T in a member is required to maintain equilibrium, the member shall be designed to carry that torsional moment in accordance with (c) to (j) below.
- (c) In a statically indeterminate structure where reduction of torsional moment in a member can occur due to redistribution of internal forces, maximum torsional moment may be reduced to $(0.06\sqrt{f'_c})\sum x^2 y$.
- (i) In such case the corresponding adjusted moments and shears in adjoining members shall be used in design.
- (ii) In lieu of exact analysis, torsional loading from a slab shall be taken uniformly distributed along the member.
- (d) Sections located less than a distance d from face of support may be designed for the same torsional moment T as that computed at a distance d .
- (e) Torsional Moment Strength

Design of cross-section subject to torsion shall be based on

$$T = T_c + T_s \quad (6.J.23)$$

Where,

T = is torsional moment at section,

T_c = is torsional moment strength provided by concrete in accordance with (f) below,

T_s = is torsional moment strength provided by torsion reinforcement in accordance with (j) below.

(f) Torsional moment strength provided by concrete

(i) Torsional moment strength T_c shall be computed by

$$T_c = \frac{(0.036\sqrt{f'_c})\sum x^2y}{\sqrt{1 + \left(\frac{0.4V}{C_tT}\right)^2}} \quad (6.J.24)$$

(ii) For members subject to significant axial tension, torsion reinforcement shall be designed to carry the total torsional moment, unless a more detailed calculation is made, in which T_c given by Eq. 6.J.24 and V_c given by Eq. 6.J.17 shall be multiplied by $\left(1 + \frac{0.3N}{A_g}\right)$, where N is negative for tension.

(g) Torsion Reinforcement Requirements

(i) Torsion reinforcement, where required, shall be provided in addition to reinforcement required to resist shear, flexure and axial forces.

(ii) Reinforcement required for torsion shall be combined with that required for other forces, provided the area furnished is the sum of individually required areas and the most restrictive requirements for spacing and placement are met.

(iii) Torsion reinforcement shall consist of closed stirrups, closed ties or spirals, combined with longitudinal bars.

(iv) Design yield strength for torsion reinforcement shall not exceed 420 N/mm².

(v) Stirrups used as torsion reinforcement shall extend to a distance d from extreme compression fibre and shall be anchored in accordance with Sec 8.2.

(vi) Torsion reinforcement shall be provided at least a distance $(bt + d)$ beyond the point theoretically required.

(h) Design of Torsion Reinforcement

- (i) Where torsional moment T exceeds torsional moment strength T_c , torsion reinforcement shall be provided to satisfy Eq. 6.J.23, where torsional moment strength T_s shall be computed by

$$T_s = 0.55 \frac{A_t x_1 y_1 f_y}{s} \quad (6.J.25)$$

Where A_t is the area of one leg of closed stirrup resisting torsion within a distance s and $\alpha_t = (2 + y_1/x_1)/3$, but not more than 1.5. Longitudinal bars distributed around the perimeter of the closed stirrup A_t shall be provided in accordance with (iii) below.

- (ii) A minimum area of closed stirrup shall be provided in accordance with Sec J.2.7.4(e).
- (iii) Required area of longitudinal bar A_l distributed around the perimeter of the closed stirrup A_t shall be computed by :

$$A_t = 2A_l \left(\frac{x_1 + y_1}{s} \right) \quad (6.J.26)$$

or,

$$A_l = \left[\frac{2.8xs}{f_y} \left(\frac{T}{T + \frac{V}{3C_t}} \right) - 2A_t \right] \left(\frac{x_1 + y_1}{s} \right) \quad (6.J.27)$$

or,

$$A_l = \left[\frac{2.8xs}{f_y} \left(\frac{T}{T + \frac{V}{3C_t}} \right) - \frac{b_w s}{3f_y} \right] \left(\frac{x_1 + y_1}{s} \right) \quad (6.J.28)$$

Whichever is the greatest

- (iv) Torsional moment strength T_s shall not exceed $4T_c$

(i) Spacing Limits for Torsion Reinforcement

- (i) Spacing of closed stirrups shall not exceed the smaller of $\left(\frac{x_1 + y_1}{4} \right)$, or 300 mm.
- (ii) Spacing of longitudinal bars, not less than 10 mm diameter, distributed around the perimeter of the closed stirrup shall not exceed 300 mm. At least one longitudinal bar shall be placed in each corner of the closed stirrups.

J.2.8 Reinforcement

J.2.8.1 At any section of a beam or one-way slab, except as provided in Sec J.2.8.2 and J.2.8.3 below, where positive reinforcement is required by analysis, the ratio ρ provided shall not be less than that given by

$$\rho_{\min} = \frac{1.38}{f_y} \quad (6.J.29)$$

In flanged beams where the web is in tension, the ratio ρ shall be computed for this purpose using the width of web.

J.2.8.2 Alternatively, area of reinforcement provided at every section, positive or negative, shall be at least one-third greater than that required by analysis.

J.2.8.3 For structural slabs of uniform thickness, minimum area and maximum spacing of reinforcement in the direction of the span shall be as required for shrinkage and temperature according to Sec 8.1.11.

J.2.8.4 Where the principal reinforcement in a slab which is considered as the flange of a T-beam (not ribbed floor) is parallel to the beam, transverse reinforcement shall be provided in the top of the slab. This reinforcement shall be designed to carry the load on the portion of the slab assumed to act as the flange of the T-beam. For isolated beams, the full width of overhanging flange shall be considered. The flange shall be assumed to act as a cantilever. The spacing of the bars shall not exceed five times the thickness of the flange, nor 450 mm. This reinforcement need not be additive to any other reinforcements required.

J.2.9 Crack Control

J.2.9.1 This section prescribes rules for distribution of flexural reinforcement to control flexural cracking in beams and in one-way slabs (slabs reinforced to resist flexural stresses in only one direction).

J.2.9.2 Flexural tension reinforcement shall be well distributed within the maximum flexural tension zone of a member cross-section as required by Sec J.2.9.3 below.

J.2.9.3 When design yield strength f_y for tension reinforcement exceeds 275 N/mm², cross-section of maximum positive and negative moment shall be so proportioned that the quantity z given by

$$z = f_s (d_c A)^{1/3} \quad (6.J.30)$$

does not exceed 30 kN/mm for interior exposure and 25 kN/mm for exterior exposure. Calculated stress in reinforcement at working load, f_s , shall be computed as the moment divided by the product of steel area and internal moment arm. In lieu of such computations, it is permitted to take f_s as 60 percent of specified yield strength of f_y .

J.2.9.4 Provisions of Sec J.2.8.3 are not sufficient for structures subject to very aggressive exposure or designed to be watertight. For such structures, special investigation and precautions are required.

J.2.9.5 When flanges of T-beam construction are in tension, part of the flexural tension reinforcement shall be distributed over an effective flange width as defined in Sec J.2.4.5 or a width equal to $\frac{1}{10}$ the span, whichever is smaller. If the effective flange width exceeds $\frac{1}{10}$ the span, some longitudinal reinforcement shall be provided in the outer portion of the flange.

J.2.9.6 If the depth of the web exceeds 900 mm, longitudinal skin reinforcement shall be uniformly distributed along both side faces of the member for a distance $d/2$ from the nearest flexural tension reinforcement. The area of skin reinforcement A_{sk} on each side face shall be at least $(d - 750)$ mm² per metre height. The maximum spacing of the skin reinforcement shall not exceed the lesser of $d/6$ and 300 mm. Such reinforcement may be included in strength computation if a strain compatibility analysis is made to determine stresses in the individual bars. The total area of longitudinal skin reinforcement in both faces need not exceed one-half of the required flexural tensile reinforcement.

J.2.10 Deflection

J.2.10.1 Beams and one-way slabs shall be designed to have adequate stiffness to limit deflections or any deformations that affect strength or serviceability of a structure adversely at working load.

J.2.10.2 Minimum thickness stipulated in Table 6.2.5.1 of Chapter 6 shall apply for beams and one-way slabs not supporting or attached to partitions or other construction likely to be damaged by large deflections, unless computation of deflection indicates a lesser thickness can be used without adverse effects.

J.2.10.3 Deflections, when computed, shall be those which occur immediately on application of the load evaluated by the usual methods or formulae for elastic deflections, considering the effects of cracking and reinforcement on member stiffness.

J.2.10.4 Unless stiffness values are obtained by a more comprehensive analysis, immediate deflection shall be computed with the modulus of elasticity E_c for concrete as specified in Sec 6.1.7, and with the effective moment of inertia I_e computed by Eq (6.2.1) of Chapter 6, but not greater than I_g .

J.2.10.5 For continuous members, effective moment of inertia may be taken as the average of values obtained from Eq (6.2.1) for the critical positive and negative moment sections. For prismatic members, effective moment of inertia may be taken as the value obtained from Eq (6.2.1) at mid-span for simple and continuous spans, and at support for cantilevers.

J.2.10.6 Unless values are obtained by a more comprehensive analysis, additional long-term deflection resulting from creep and shrinkage of flexural members shall be determined by multiplying the immediate deflection caused by the sustained load considered, by the factor λ_{Δ} as determined from Eq (6.2.4) of Chapter 6.

J.2.10.7 Deflections computed in accordance with Sec J.2.10.3 through J.2.10.6 shall not exceed the limits stipulated in Table 6.2.5.2 of Chapter 6.

J.3 Columns

Sections J.3.1 to J.3.5 as detailed hereunder along with the Sec 6.3, except Sections 6.3.2.1 to 6.3.2.7, and 6.3.3, shall form part of this section. In case of any conflict, the provisions of this Appendix B shall prevail.

In using the provisions of Sec 6.3, the word factored shall be read as working or working load whichever is applicable.

J.3.1 Definitions and Notation

J.3.1.1 Notation

All the notation used this Section are provided in Sec. J.1.1. For other symbols used in this section but not provided in Sec J.1.1, the notation given in Sec 6.1.1 shall be applicable.

J.3.1.2 Definitions: The definitions given in Chapter 6 shall apply to this section. In applying the provision of Chapter 6, the terms P_u and Δ_u shall be replaced by their working load counterparts P and Δ respectively.

J.3.2 Design Assumptions

J.3.2.1 The design assumptions specified in Sec J.1.3 are valid for this section.

J.3.2.2 The provisions of Sec 6.3.8.2 and 6.3.8.3 shall apply to this section.

J.3.3 General Principles and Requirements

J.3.3.1 Design of cross-section subject to flexure, or to axial loads, or to combined flexure and axial loads shall be based on design assumptions of Sec J.1.3.

J.3.3.2 All compression members, with or without flexure, shall be proportioned using the ultimate strength design method.

J.3.3.3 Combined flexure and axial load capacity of compression members shall be taken as 40 percent of that computed in accordance with the provisions of Chapter 6 of this part.

J.3.3.4 Design axial load P of compression members shall not be taken greater than the following :

(a) For members with spiral reinforcement conforming to Sec 8.1.9.3 or composite compression member conforming to Sec 6.3.13 :

$$P_{\max} = 0.289f'_c A_g + (0.34f_y - 0.289f'_c) A_{st} \quad (6.J.31)$$

(b) For members with tie reinforcement conforming to Sec 8.1.9.4

$$P_{\max} = 0.272f'_c A_g + (0.32f_y - 0.272f'_c) A_{st} \quad (6.J.32)$$

J.3.3.5 Members subject to compressive axial load shall be designed for maximum moment that can accompany the axial load. The axial load P at given eccentricity shall not exceed that given in Sec J.3.3.4 above. The maximum moment M shall be magnified for slenderness effects in accordance with Sec J.3.4.

J.3.4 Slenderness Effects

J.3.4.1 Slenderness effects shall be included in accordance with the requirements of Sec. 6.3.10.

J.3.4.2 In applying the provisions of Sec. 6.3.10, the following convention and modification shall be used:

- (a) the term factored shall be replaced by working or working load as the context implies,
- (b) the value of strength reduction factor ϕ shall be taken as unity, and
- (c) the term P_u shall be replaced by 2.5 times the design axial working load P when gravity loads govern the design, and by 1.875 times P when gravity loads combined with wind or earthquake forces govern the design.

J.3.5 Reinforcement

Column reinforcements shall comply with the requirements of Sec 6.3.9.

J.4 Flat Plates, Flat Slabs and Edge-Supported Slabs

J.4.1 General

General requirements for the design of slabs by working stress design method shall be the same as those specified in Sec 6.5 of Chapter 6.

The provisions of Sec 6.5 except those for nominal strength evaluation shall also be applicable along with the provisions of this section.

In using Sec 6.5, the word factored shall be read as working or working load whichever is applicable and the factor ϕ shall be taken as unity.

J.4.2 The shear strength of slabs in the vicinity of columns, concentrated loads or reactions is governed by the more severe of the following two conditions:

- (a) Beam action for slab, with critical section extending in a plane across the entire width and located at a distance d from the face of columns, concentrated loads or reaction. For this condition, the slab shall be designed in accordance with Sec J.2.7.1 through J.2.7.4.
- (b) Two way action for slab, with a critical section perpendicular to plane of slab and located so that its perimeter is a minimum, but need not approach closer than $d/2$ to:
 - (i) edges or corners of columns, concentrated loads or reaction areas or
 - (ii) change in slab thickness such as edges of capitals or drop panels.

For two way action, the slab shall be designed in accordance with Sec J.4.3 and J.4.4.

J.4.3 Design shear stress shall be computed by

$$v = \frac{V}{b_o d} \quad (6.J.33)$$

Where V and b_o shall be taken at the critical section defined in Sec J.4.2(b) above.

J.4.4 Design shear stress v shall not exceed v_c given by Eq. 6.J.34 unless shear reinforcement is provided.

$$v_c = 0.083 \left(1 + \frac{2}{\beta_c} \right) \sqrt{f'_c} \leq 0.17 \sqrt{f'_c} \quad (6.J.34)$$

Where β_c is the ratio of long side to short side of concentrated load or reaction area.

- J.4.5** If shear reinforcement consisting of bars or wires is used in accordance with Sec 6.4.3, v_c shall not exceed $0.083\sqrt{f'_c}$, and v shall not exceed $0.25\sqrt{f'_c}$.
- J.4.6** If shear reinforcement in the form of shear heads is used in accordance with Sec 6.4.10.4, v on the critical section, as defined in Sec J.4.2.(b) above, shall not exceed $0.29\sqrt{f'_c}$ and v on the critical section, as defined in Sec 6.4.10.4.7, shall not exceed $0.17\sqrt{f'_c}$. In using Equations 6.6.75 and 6.6.76, the quantity v_u shall be replaced by 2 times the design working shear force V .

J.5 Alternative Design of Two-Way Edge-Supported Slabs

- J.5.1** The provisions of this section may be used as alternative to those of Sec J.4 for two-way slabs supported on all four edges by walls, steel beams or monolithic concrete beams having a total depth not less than 3 times the slab thickness.
- J.5.2** The provisions of Sec 6.5.8 (except as may be superseded by the provisions of Appendix B), shall also form a part of this section. In using the provisions of Sec 6.5.8, the word factored shall be read as working or working load as the context implies, and the factor ϕ shall be taken as unity.

J.5.3 Analysis by the Coefficient Method

The slab may be analysed for the determination of negative moments and dead and live load positive moments in accordance with the provisions of Sec. 6.5.8.3.

J.5.4 Flexural Design of Slabs

The flexural design of slabs shall be performed in accordance with the provisions of Sec J.2.6.1.

J.5.5 Shear Strength of Slabs

The shear strength of slabs shall be provided in accordance with the requirements of Sec J.4.2 through J.4.6.

J.6 Ribbed and Hollow Slabs

General requirements for the design of ribbed and hollow slabs by the working stress design method shall be in accordance with Sec 6.5.9 Chapter 6. The provisions of Sec 6.5.9 except Sec 6.5.9.3 shall also form a part of this section.

J.6.1 In applying the provisions of Sec 6.5.9, the word factored shall be read as working or working load as the context implies, and the factor ϕ shall be taken as unity.

J.6.2 Ribbed and hollow slabs shall be designed for flexure in accordance with Sec J.2.6.

J.6.3 The shear strength of ribbed and hollow slabs shall be provided to satisfy the requirements of Sec J.4.2 through J.4.6, except as specified in Sec J.6.4 below.

J.6.4 For one-way ribbed and hollow slab construction, contribution of concrete to shear strength V_c is permitted to be 10 percent more than that specified in Sec J.2.7. It is allowed to increase shear strength using shear reinforcement or by widening the ends of ribs.

J.7 Framed Structures

J.7.1 Scope

The provisions of this section shall apply to rigidly jointed RC framed structures subject to lateral loads in addition to gravity loads.

J.7.2 Continuity

All intersections of members in a framed structure shall be continuous, with the steel reinforcements continued through the joints into the adjacent members to provide adequate development length. At construction joints, special care shall be taken to bond the new concrete to the old by carefully cleaning the latter, by extending the reinforcement through the joint and by other means.

J.7.3 Placement of Loads

All individual members and joints of the framed structure shall be designed for the worst combination of loads as provided in Sec 2. Gravity live loads in different bays and in different storeys of a framed structure shall be so arranged as to produce the maximum moment and shear at all critical sections.

J.7.4 Idealization

J.7.4.1 For the purpose of analysis, the members of the frame shall be represented by straight lines coincident with their centroidal axes. When the centroidal axes of the members meeting at a joint do not coincide at a single point, the effect of offset from the point representing the joint shall be taken into consideration.

J.7.4.2 Use of any set of reasonable assumptions is permitted for computing relative flexural and torsional stiffness of columns, walls, floors, and roof systems. The assumptions adopted shall be consistent throughout the analysis.

J.7.4.3 The moment of inertia of the frame members shall be based on the gross concrete cross-section.

J.7.4.4 Effect of haunches shall be considered both in determining moments and in the design of members.

J.7.4.5 Columns having their bases monolithically cast in a substantial foundation, which may be anchored to a solid rock mass or supported on piles with their tops encased in pile cap, or which is a continuous raft or mat, may be assumed to be fixed at their bases. Otherwise, the column bases shall be assumed to permit rotation. In either case, the foundation shall be designed to resist any moment that may be transferred to it from the structure in view of the assumptions made and the detailing used at the base.

J.7.5 Method of Analysis

J.7.5.1 Gravity Loads: For building frames with reasonably regular outline, not involving unusual asymmetry of loading or shape, moments due to gravity loads may be determined by dividing the entire frame into simpler sub-frames. Each sub-frame shall consist of one continuous beam, plus the top and bottom columns framing into that particular beam. The far ends of the columns, built integrally with the structure, shall be considered fixed. For the sub-frame at the bottom of the structure, the column end conditions at the base shall be dictated by the soil and foundation considerations in accordance with Sec J.7.4.5 above.

The arrangement of live load on the sub-frame may be limited to the combinations, (a) dead load on all spans with full live load on two adjacent spans, and (b) dead load on all spans with full live load on alternate spans.

For building frames not satisfying the requirements above, a full frame analysis using elastic method shall be carried out for gravity loads.

J.7.5.2 Lateral Loads: Any method of elastic analysis that satisfies equilibrium and compatibility requirements may be used for framed structures. Approximate methods that reduce the frame to a statically determinate structure by making simplifying assumptions shall not be used except for preliminary proportioning of sections for subsequent more accurate analysis.

J.7.6 Design

The frame members shall be designed for the shear, moment, torsion and axial force obtained from the elastic analysis. All members of frames shall be designed for the maximum effects of working loads using allowable working load stresses. The critical section for design for negative moment in beams may be assumed to be at the face of the support.

J.8 Deep Beams

J.8.1 Notation

All the notation used this Section are provided in Sec. J.1.1.

J.8.2 General

J.8.2.1 Flexural members with overall depth to clear span ratio greater than 0.4 for continuous spans, or 0.5 for simple spans, shall be designed as deep beams taking into account nonlinear distribution of strain and lateral buckling (See also Sec 8.2.7.6).

J.8.2.2 Shear strength of deep beams shall be provided in accordance with Sec J.8.4 below.

J.8.2.3 Minimum flexural tension reinforcement shall conform to Sec J.2.8.

J.8.2.4 Minimum horizontal and vertical reinforcement in the side faces of deep beams shall satisfy the requirements of Sec J.8.4.8, J.8.4.9 and J.8.4.10 below, but the reinforcement shall not be less than that required for walls in Sec 6.6.3.2 and 6.6.3.3.

J.8.3 Flexure

Deep flexural members shall be designed as beams. The lever arm, z , shall be computed in compatibility with Sec. 6.3.7, 6.4.6, and Appendix I.

J.8.4 Shear

J.8.4.1 The provisions of this section shall apply to members with $\frac{l_n}{d}$ less than 5 that are loaded on one face and supported on the opposite face so that compression stress can develop between the loads and the supports.

J.8.4.2 The design of simply supported deep beams for shear shall be based on Sec J.2.7.1. The shear strength provided by concrete, V_c , shall be computed in accordance with Sec J.8.4.6 or J.8.4.7 and that provided by steel, V_s , in accordance with Sec J.8.4.8.

J.8.4.3 The design of continuous deep beams for shear shall be based on Sections J.2.7.1 to J.2.7.5 or on any method satisfying equilibrium, compatibility and strength requirements. In either case the design shall also satisfy Sec J.8.4.4, J.8.4.9 and J.8.4.10 below.

J.8.4.4 Shear strength V_n for deep beams shall not be taken greater than $0.37\sqrt{f'_c}b_wd$ when $\frac{l_n}{d}$ is less than 2. When $\frac{l_n}{d}$ lies between 2 and 5,

$$V_n = 0.31 \left(10 + \frac{l_n}{d}\right) \sqrt{f'_c} b_w d \quad (6.J.35)$$

J.8.4.5 Critical section for shear shall be taken at a distance of $0.15 \ell_n$ for uniformly loaded beams and $0.50a$ for beams with concentrated loads, measured from the face of support, but in either case not greater than d .

J.8.4.6 Unless a more detailed calculation is made in accordance with Sec J.8.4.7, V_c shall be taken as

$$V_c = 0.091\sqrt{f'_c}b_wd \quad (6.J.36)$$

J.8.4.7 Shear strength V_c may be computed more accurately by

$$V_c = \left(1.93 - 1.38 \frac{M}{Vd}\right) \left(0.16\sqrt{f'_c} + 17.2\rho_w \frac{Vd}{M}\right) b_w d \quad (6.J.37)$$

Except that the term $\left(1.93 - 1.38 \frac{M}{Vd}\right)$ shall not exceed 1.38 and V_c shall not to be taken greater than $0.275\sqrt{f'_c}b_wd$.

J.8.4.8 Where shear force V exceeds shear strength V_c , shear reinforcement shall be provided to satisfy the requirement of Sec J.2.7.1. The shear strength, V_s , contributed by shear reinforcement shall be computed by

$$V_s = \left[\frac{A_v}{s} \left(\frac{1 + \frac{l_n}{d}}{12} \right) + \frac{A_{vh}}{s_1} \left(\frac{11 - \frac{l_n}{d}}{12} \right) \right] f_s d \quad (6.J.38)$$

Where A_v is the area of shear reinforcement perpendicular to flexural tension reinforcement within a distance s , and A_{vh} is the area of shear reinforcement parallel to flexural reinforcement within a distance s_1 .

J.8.4.9 Area of shear reinforcement A_v shall not be less than $0.0015 b_w s$, and s shall not exceed $d/5$, nor 450 mm.

J.8.4.10 The area of horizontal shear reinforcement A_{vh} shall not be less than $0.0025 b_w s_1$ and s_1 shall not exceed $d/3$, nor 450 mm.

J.8.4.11 Shear reinforcement required at the critical section defined in Sec J.8.4.5 shall be used throughout the span.

J.9 Reinforced Concrete Walls

J.9.1 General requirements for and analysis of reinforced concrete walls for design by the working stress design method shall be the same as those specified in Sec. 6.4.8 and Sec 6.6.

In applying the provision of Sec. 6.4.8 and Sec 6.6, the word factored shall be read as working or working load as the context implies.

J.9.2 Walls shall be designed in accordance with Sec 6.6 with flexural and axial load capacities taken as 40 percent of that computed using Sec 6.6. Strength reduction factor ϕ shall be taken equal to 1.0.

J.9.3 In computing the effect of slenderness, the quantity P_u shall be taken as $2.5P$ when gravity loads govern the design and as $1.875P$ when lateral loads combined with gravity loads govern the design, where P is the design working axial load in the wall.

J.9.4 Design of walls for shear shall be in accordance with the provisions of Sec 6.4.8 except the following :

J.9.4.1 Shear strengths provided by concrete and the limiting maximum strengths for shear shall be taken as 55 percent of the values given in Sec 6.4.8.

J.9.4.2 In Sec 6.4.8.6, N_u shall be replaced by 2 times the design axial load for tension and 1.2 times the design axial load for compression.

J.9.4.3 The terms V_u and M_u shall be replaced by their working load values V and M respectively.

J.10 Footings

J.10.1 General requirements for the design of footings by the working stress design method shall be the same as those specified in Sec 6.4.10 and 6.8.

J.10.2 In using the provisions of Sec 6.4.10 and 6.8, the word factored shall be read as working or working load as the context implies, and the value of strength reduction factor ϕ shall be taken as 1.0.

J.10.3 Footings (combined or isolated), mats or pile caps shall be designed to resist the service loads and induced reactions in accordance with the appropriate design requirements of this chapter.

J.10.4 For flexural design of footings, the provisions of Sec 6.8.4 shall be applicable.

J.10.5 Development of reinforcement shall be provided in accordance with Sec 6.8.6.

J.10.6 The requirements of Sec 6.8.8 for transfer of force at base shall be applicable except the following:

J.10.6.1 The limiting bearing stress in Sec 6.8.8.1.1 and 6.3.14.1 shall be $0.3f'_c$ instead of $0.85\phi f'_c$.

J.10.6.2 When supporting surface is wider on all sides than the loaded area, the limiting bearing stress in Sec 6.8.8.1.1 and 6.3.14.1 shall be $0.3f'_c\sqrt{A_2/A_1}$ instead of $0.85\phi f'_c\sqrt{A_2/A_1}$. Where, the root of the area ratio is not to be taken larger than 2.

J.10.7 The provisions of Sec 6.8.9 for sloped or stepped footings and Sec 6.8.10 for combined footings and mats shall be applicable.

J.10.8 Shear in Footings

J.10.8.1 Shear capacity of footings in the vicinity of concentrated loads or reactions is governed by the more severe of the following two conditions :

- (a) Beam action for footing, with a critical section extending in a plane across the entire width and located at a distance d from face of concentrated load or reaction area. For this condition, the footing shall be designed in accordance with Sec J.2.7.1 through J.2.7.4.
- (b) Two-way action for footing, with a critical section perpendicular to plane of footing and located so that its perimeter is a minimum, but the critical section need not approach closer than $d/2$ to perimeter of concentrated load or reaction area. For this condition, the footing shall be designed in accordance with Sec J.10.2.2 and J.10.2.3.

J.10.8.2 Design shear stress v shall be computed by

$$v = \frac{V}{b_o d} \quad (6.J.39)$$

Where V and b_o shall be taken at the critical section defined in J.10.8.1(b) above.

J.10.8.3 Design shear stress v shall not exceed v_c given by Eq. 6.J.40 unless shear reinforcement is provided

$$v_c = \left(0.083 + \frac{0.17}{\beta_c} \right) \sqrt{f'_c} \leq 0.17 \sqrt{f'_c} \quad (6.J.40)$$

Where β_c is the ratio of long side to short side for concentrated load or reaction area.

J.10.8.4 If shear reinforcement consisting of bars or wires is provided in the footings, v_c shall not exceed $0.083\sqrt{f'_c}$, and v shall not exceed $0.25\sqrt{f'_c}$. The required area of shear reinforcement A_v shall be calculated in accordance with Sec J.2.7.4 and anchored in accordance with Sec 8.2.

J.10.9 Pile Caps

J.10.9.1 Pile caps shall be designed either by bending theory or by truss analogy.

J.10.9.2 Truss analogy method

- (a) When truss method is used, the truss shall be of triangulated form, with a node at the centre of loaded area. The lower nodes of the truss shall lie at the intersections of the centre lines of the piles with the tensile reinforcement.
- (b) Where the truss method is used with widely spaced piles (spacing exceeding three times the pile diameter), only the reinforcement within a band width of 1.5 times the pile diameter from the centre of a pile shall be considered to constitute a tension member of the truss.

J.10.9.3 Beam shear in pile cap shall be checked at critical sections extending across the full width of the cap. Critical sections shall be assumed to be located at 20% of the diameter of the pile inside the face of the pile. The total force from all the piles with centres lying outside this line shall be considered to constitute the shear force on this section.

The shear force V on the critical section shall not exceed V_c , where

$$V_c = 0.4\sqrt{f'_c}bd(2d/a_v) \quad (6.J.41)$$

in which $2d/a_v$ shall be greater than or equal to 1.0, a_v is the distance from the face of the column to the critical section as defined above, and b shall be taken as the full width of the critical section if the spacing of the piles is less than or equal to 3 times the pile diameter d_p , otherwise b shall be equal to 3 times the pile diameter.

J.10.9.4 Punching Shear: A check shall be made to ensure that the shear stress calculated at the perimeter of the column for the working loads does not exceed $0.4\sqrt{f'_c}$ or 2.5 N/mm^2 , whichever is the smaller. In addition, if the spacing of the piles is greater than 3 times the pile diameter, punching shear shall be checked on the perimeter defined in Sec. J.10.9.3, in accordance with Sec 6.4.10.

J.10.9.5 Anchorage: The tension reinforcement shall be provided with full anchorage in accordance with Sec 8.2.

J.11 Stairs

Requirements for the design of stairs by the working stress design method shall be in accordance with Sec 6.7 except the following:

- (a) Staircases shall be designed to support design working loads in accordance with the provisions of Sec J.1.4.
- (b) The provisions for beams and one-way slabs given in Sec J.2 shall apply for the design of stairs.

J.12 Shells and Folded Plates

Requirements for the design of shells and folded plates by the working stress design method shall be in accordance with Sec 6.9 Chapter 6 except the following:

- (a) All provisions of Sections J.1 and J.2 shall apply to thin-shell structures.
- (b) A portion of the shell equal to the flange width specified in Sec J.2.4.5 may be assumed to act with the auxiliary member. In such portions of the shell, the reinforcement perpendicular to the auxiliary member shall be at least equal to that required for the flange of a T-beam by Sec J.2.8.4.
- (c) Reinforcement required to resist shell membrane forces shall be provided so that the design strength in every direction shall be at least equal to the component of the principal membrane forces in the shell in the same direction due to working loads.
- (d) Where the principal membrane tensile stress on the gross concrete area due to working loads exceeds $0.17\sqrt{f'_c}$ reinforcement shall not be spaced farther apart than three times the shell thickness.
- (e) Design for flexure shall be in accordance with Sec J.2.6.

J.13 Precast and Composite Construction

Requirements for the design of precast and composite construction by the working stress design method shall be in accordance with Sections 6.10, 6.2.5.4, 6.3.13, and 6.12 except the following:

J.13.1 For design of composite concrete flexural members, allowable horizontal shear strength V_h shall not exceed 55 percent of the horizontal shear strengths V_{nh} given in Sec 6.12.5.3.

J.13.2 When an entire composite member is assumed to resist vertical shear, design shall be in accordance with requirements of Sec J.2.7 as for a monolithically cast member of the same cross-sectional shape.

J.13.3 Design for flexure shall be in accordance with Sec J.2.6.

J.13.4 Shear-friction provision of Sec 6.4.5 shall be applied with limiting maximum stress for shear taken as 55 percent of that given. Allowable stress in shear friction reinforcement shall be that given in Sec J.1.10.

PART VI
Appendix K
Anchoring to Concrete

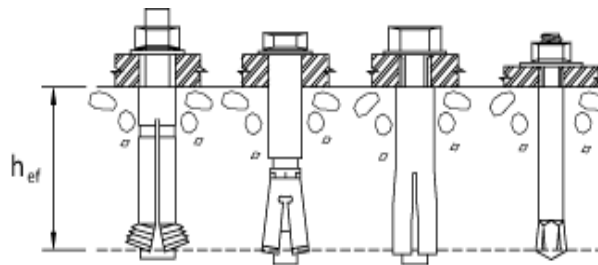
K.1 Definitions

ANCHOR	A steel element used to transmit applied loads either by casting into concrete or post-installed into a hardened concrete member. An anchor includes headed bolts, hooked bolts (J- or L-bolt), headed studs, expansion anchors, or undercut anchors.
ANCHOR GROUP	Anchor group is formed by a number of anchors of approximately equal effective embedment depth with each anchor spaced at less than $3h_{ef}$ from one or more adjacent anchors when subjected to tension, or $3c_{a1}$ from one or more adjacent anchors when subjected to shear. Only those anchors susceptible to the particular failure mode under investigation shall be included in the group.
CLARIFICATION FOR ANCHOR GROUP	Only those anchors susceptible to a particular failure mode out of all potential modes (steel, concrete breakout, pullout, side-face blowout, and pryout) should be considered when evaluating the strength associated with that failure mode.
ANCHOR PULLOUT STRENGTH	The strength corresponding to the anchoring device or a major component of the device sliding out from the concrete without breaking out a substantial portion of the surrounding concrete.
ANCHOR REINFORCEMENT	It is the reinforcement used to transfer the full design load from the anchors into the structural member. See Sec K.5.2.9 or Sec K.6.2.9.
CLARIFICATION FOR ANCHOR REINFORCEMENT	The design and detailing of anchor reinforcement is done specifically for the purpose of transferring anchor loads from the anchors into the structural member. Hairpins are generally used for this purpose (see Clarification for Sections K.5.2.9 and K.6.2.9); however, other configurations that can be shown to effectively transfer the anchor load are acceptable.
ATTACHMENT	The structural assembly, external to the surface of the concrete, that transmits loads to or receives loads from the anchor.

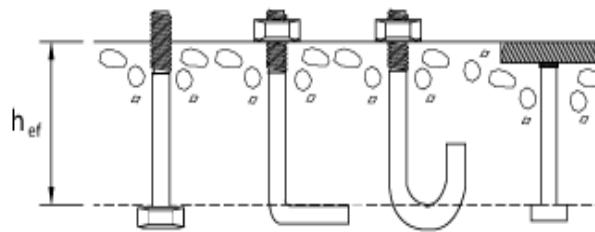
BRITTLE STEEL ELEMENT	An element having a tensile test elongation of less than 14 percent, or reduction in area of less than 30 percent, or both.
CLARIFICATION FOR BRITTLE STEEL ELEMENT AND DUCTILE STEEL ELEMENT	The gauge length specified in the appropriate ASTM standard for the steel shall be used for measuring the 14 percent elongation.
CAST-IN ANCHOR	An anchor either a headed bolt, headed stud, or hooked bolt installed before placing concrete.
CONCRETE BREAKOUT STRENGTH	The strength corresponding to which a volume of concrete surrounding the anchor or group of anchors separates from the member.
CONCRETE PRYOUT STRENGTH	The strength corresponding to formation of a concrete spall behind short, stiff anchors displaced in the direction opposite to the applied shear force.
DISTANCE SLEEVE	A sleeve that encases the center part of an undercut anchor, a torque-controlled expansion anchor, or a displacement-controlled expansion anchor without expanding.
DUCTILE STEEL ELEMENT	An element with a tensile test elongation of not less than 14 percent and reduction in area of at least 30 percent. A steel element meeting the requirements of ASTM A307 shall be considered ductile.
EDGE DISTANCE	The distance to the edge of the concrete surface from center of the anchor closest to edge.
EFFECTIVE EMBEDMENT DEPTH	It is the overall depth through which the anchor transfers force to or from the surrounding concrete. The effective embedment depth will normally be the depth of the concrete failure surface in tension applications. For cast-in headed anchor bolts and headed studs, the effective embedment depth is measured from the bearing contact surface of the head.
CLARIFICATION FOR EFFECTIVE EMBEDMENT DEPTH	Figure 6.K.1 illustrates the effective embedment depths for a variety of anchor types.

EXPANSION ANCHOR	It is a post-installed anchor, inserted into hardened concrete and it transfers loads to or from the concrete by direct bearing or friction or both. Expansion anchors may be torque-controlled, where the expansion is achieved by a torque acting on the screw or bolt; or displacement-controlled, where the expansion is achieved by impact forces acting on a sleeve or plug and the expansion is controlled by the length of travel of the sleeve or plug.
EXPANSION SLEEVE	The outer part of an expansion anchor that is forced outward by the center part, either by applied torque or impact, to bear against the sides of the predrilled hole.
FIVE PERCENT FRACTILE	Statistically it means 90 percent confidence that there is 95 percent probability of the actual strength exceeding the nominal strength.
CLARIFICATION FOR FIVE PERCENT FRACTILE	The coefficient K_{05} associated with the 5 percent fractile, $X_m - K_{05}S_s$ is determined depending on the number of tests, n , used to compute the sample mean, X_m , and sample standard deviation, S_s . Values of K_{05} range, for example, from 1.645 for $n = \infty$, to 2.010 for $n = 40$, and 2.568 for $n = 10$. With this definition of the 5 percent fractile, the nominal strength in K.4.2 is the same as the characteristic strength in ACI 355.2.
HEADED STUD	A steel anchor conforming to the requirements of AWS D1.1 and affixed to a plate or similar steel attachment by the stud arc welding process before casting.
HOOKED BOLT	A cast-in anchor, which is anchored mainly by bearing of the 90° bend (L-bolt) or 180° bend (J-bolt) against the concrete, at its embedded end, and having a minimum e_h of $3d_a$.
POST-INSTALLED ANCHOR	An anchor installed in concrete, which is hardened. Expansion anchors and undercut anchors are examples of post-installed anchors.
PROJECTED AREA	The area on the free surface of the concrete member that is used to represent the larger base of the assumed rectilinear failure surface.
SIDE-FACE BLOWOUT STRENGTH	The strength of anchors with deeper embedment but thinner side cover corresponding to concrete spalling on the side face around the embedded head while no major breakout occurs at the top concrete surface.

SPECIALTY INSERT	Pre-designed and prefabricated cast-in anchors specifically designed for attachment of bolted or slotted connections. Specialty inserts are often used for handling, transportation, and erection, but are also used for anchoring structural elements. Specialty inserts are not within the scope of this Appendix.
SUPPLEMENTARY REINFORCEMENT	Reinforcement which acts to restrain potential concrete breakout which is not designed to transfer full design load from the anchors into the structural member.
CLARIFICATION FOR SUPPLEMENTARY REINFORCEMENT	Supplementary reinforcement has a configuration and placement similar to anchor reinforcement but is not specifically designed to transfer loads from the anchors into the structural member. Stirrups for shear reinforcement may fall into this category.
UNDERCUT ANCHOR	It is a post-installed anchor that develops its tensile strength from the mechanical interlock provided by undercutting of the concrete at the embedded end of the anchor. The undercutting is achieved with a special drill before installing the anchor or alternatively by the anchor itself during its installation.



(a) Post-installed anchors



(b) Cast-in-place anchors

Figure 6.K.1 Types of anchors.

K.2 Scope

K.2.1 In this Appendix design requirements are provided for anchors in concrete used to transmit structural loads by means of tension, shear, or a combination of tension and shear between: (a) connected structural elements; or (b) safety-related attachments and structural elements. Safety levels specified are intended for in-service conditions, rather than for short-term handling and construction conditions.

Clarification for Section K.2.1: The scope of Appendix K is restricted to structural anchors that transmit structural loads related to strength, stability, or life safety. Two types of applications are envisioned. The first one is connections between structural elements where the failure of an anchor or an anchor group could result in loss of equilibrium or stability of any portion of the structure. The second one is where safety-related attachments that are not part of the structure (such as sprinkler systems, heavy suspended pipes, or barrier rails) are attached to structural elements. The levels of safety defined by the combinations of load factors and ϕ factors are appropriate for structural applications. Other standards may require more stringent safety levels during temporary handling.

K.2.2 This Appendix is applicable to both cast-in anchors and post-installed anchors. Specialty inserts, through bolts, multiple anchors connected to a single steel plate at the embedded end of the anchors, adhesive or grouted anchors, and direct anchors such as powder or pneumatic actuated nails or bolts, are not included. Reinforcement used as part of the embedment shall be designed in accordance with other parts of this Code.

Clarification for Section K.2.2: It is difficult to prescribe generalized tests and design equations for many insert types because of the wide variety of shapes and configurations of specialty inserts. Hence, they have been excluded from the scope of Appendix K. Adhesive anchors are widely used and can perform adequately. However, such anchors are outside the scope of this Appendix at this time.

K.2.3 Headed bolts and headed studs having a geometry that has been demonstrated to result in a pullout strength in uncracked concrete equal or exceeding $1.4N_p$ (where N_p is given by Eq. 6.K.15) are included. Hooked bolts that have a geometry that has been demonstrated to result in a pullout strength without the benefit of friction in uncracked concrete equal or exceeding $1.4N_p$ (where N_p is given by Eq. 6.K.16) are included. Post-installed anchors that meet the assessment requirements of ACI 355.2 are included. The suitability of the post-installed anchor for use in concrete shall have been demonstrated by the ACI 355.2 prequalification tests.

Clarification for Section K.2.3: Typical cast-in headed bolts and headed studs with geometries consistent with ANSI/ASME B1.1,^{K.1} B18.2.1,^{K.2} and B18.2.6^{K.3} have been tested and proven to behave predictably, so calculated pullout values are acceptable. Post-installed anchors do not have predictable pullout capacities, and therefore are required to be tested. For a post-installed anchor to be used in conjunction with the requirements of this Appendix, the results of the ACI 355.2 tests have to indicate that pullout failures exhibit an acceptable load-displacement characteristic or that pullout failures are precluded by another failure mode.

K.2.4 This Appendix does not cover the load applications that are predominantly high cycle fatigue or impact loads.

Clarification for Section K.2.4: The exclusion of load applications producing high cycle fatigue or extremely short duration impact (such as blast or shock wave), however, does not mean that seismic load effects are excluded from the scope. K.3.3 presents additional requirements for design when seismic loads are included.

K.3 General Requirements

K.3.1 Anchors and anchor groups shall be designed for critical effects of factored loads determined through elastic analysis. Plastic analysis approaches are permitted where nominal strength is controlled by ductile steel elements, provided that deformational compatibility is taken into account.

Clarification for Section K.3.1: If the strength of an anchor group is governed by breakage of the concrete, the behavior is brittle and there is limited redistribution of the forces between the highly stressed and less stressed anchors. In this case, the theory of elasticity is required to be used assuming the attachment that distributes loads to the anchors is sufficiently stiff. The forces in the anchors are considered to be proportional to the external load and its distance from the neutral axis of the anchor group.

If anchor strength is governed by ductile yielding of the anchor steel, significant redistribution of anchor forces can occur. In this case, an analysis based on the theory of elasticity will be conservative. References K.4 to K.6 discuss nonlinear analysis, using theory of plasticity, for the determination of the capacities of ductile anchor groups.

K.3.2 The design strength of anchors shall equal or exceed the largest required strength calculated from the applicable load combinations in Sec 6.2.2.

K.3.3 When anchor design includes earthquake forces for structures assigned to Seismic Design Category C, or D, the additional requirements of Sections K.3.3.1 to K.3.3.6 shall apply.

Clarification for Section K.3.3: Post-installed structural anchors are required to be qualified for Seismic Design Categories C, or D, by demonstrating the ability to undergo large displacements through several cycles as specified in the seismic simulation tests of ACI 355.2. Because ACI 355.2 excludes plastic hinge zones, Appendix K is not applicable to the design of anchors in plastic hinge zones under seismic forces. In addition, the design of anchors for earthquake forces is based on a more conservative approach by the introduction of 0.75 factor on the design strength ϕN_n and ϕV_n for the concrete failure modes, and by requiring the system to have adequate ductility. Anchor strength should be governed by ductile yielding of a steel element. If the anchor cannot meet these ductility requirements, then either the attachment is designed to yield or the calculated anchor strength is substantially reduced to minimize the possibility of a brittle failure. In designing attachments for adequate ductility, the ratio of yield to design strength should be considered. A connection element could yield only to result in a secondary failure as one or more elements strain harden and fail if the design strength is excessive when compared to the yield strength.

The full shear force should be assumed in any direction for a safe design as the direction of shear may not be predictable under seismic conditions.

K.3.3.1 The provisions of Appendix K are not applicable to the design of anchors in plastic hinge zones of concrete structures under earthquake forces.

Clarification for Section K.3.3.1: Section 3.1 of ACI 355.2 specifically states that the seismic test procedures do not simulate the behavior of anchors in plastic hinge zones. The possible higher level of cracking and spalling in plastic hinge zones are beyond the damage states for which Appendix K is applicable.

K.3.3.2 Post-installed structural anchors shall be qualified for use in cracked concrete and shall have passed the Simulated Seismic Tests in accordance with ACI 355.2. Pullout strength N_p and steel strength of the anchor in shear V_{sa} shall be based on the results of the ACI 355.2 Simulated Seismic Tests.

Clarification for Section K.3.3.2: Anchors that are not suitable for use in cracked concrete should not be used to resist seismic loads.

K.3.3.3 The design strength of anchors associated with concrete failure modes shall be taken as $0.75\phi N_n$ and $0.75\phi V_n$, where ϕ is given in K.4.4, and N_n and V_n are determined in accordance with Sections K.5.2, K.5.3, K.5.4, K.6.2, and K.6.3, assuming the concrete is cracked unless it can be demonstrated that the concrete remains uncracked.

Clarification for Section K.3.3.3: The anchor strength associated with concrete failure modes is to account for increased damage states in the concrete resulting from seismic actions. Because seismic design generally assumes that all or portions of the structure are loaded beyond yield, it is likely that the concrete is cracked throughout for the purpose of determining the anchor strength unless it can be demonstrated that the concrete remains uncracked.

K.3.3.4 Anchors shall be designed to be governed by the steel strength of a ductile steel element as determined in accordance with Sections K.5.1 and K.6.1, unless either Sec K.3.3.5 or Sec K.3.3.6 is satisfied.

Clarification for Section K.3.3.4: Ductile steel anchor elements are required to satisfy the requirements of K.1, Ductile Steel Element. For anchors loaded with a combination of tension and shear, the strength in all loading directions must be controlled by the steel strength of the ductile steel anchor element.

K.3.3.5 Instead of K.3.3.4, the attachment that the anchor is connecting to the structure shall be designed so that the attachment will undergo ductile yielding at a force level corresponding to anchor forces no greater than the design strength of anchors specified in K.3.3.3.

K.3.3.6 Alternative to K.3.3.4 and K.3.3.5, it shall be allowed to take the design strength of the anchors as 0.4 times the design strength determined in accordance with K.3.3.3. For the anchors of stud bearing walls, it shall be allowed to take the design strength of the anchors as 0.5 times the design strength determined in accordance with K.3.3.3.

Clarification for Section K.3.3.6: As a matter of desirable practice, a ductile failure mode in accordance with K.3.3.4 or K.3.3.5 should be provided for in the design of the anchor or the load should be transferred to anchor reinforcement in the concrete. Where geometric or material constraints do not permit, K.3.3.6 allows the design of anchors for nonductile failure modes at a reduced permissible strength to minimize the possibility of a brittle failure. The attachment of light frame stud walls typically involves multiple anchors that allow for load redistribution. This justifies the use of a less conservative factor for this case.

K.3.4 In this Appendix, modification factor λ for lightweight concrete shall be in accordance with Sec 6.1.8.1 unless specifically noted otherwise.

K.3.5 The values of f'_c used for calculation purposes in this Appendix shall not be greater than 70 MPa for cast-in anchors, and 55 MPa for post-installed anchors. Testing is required for post-installed anchors when used in concrete with f'_c exceeding 55 MPa.

Clarification for Section K.3.5: Limited tests of cast-in-place and post-installed anchors in high-strength concrete^{K.7} indicate that the design procedures contained in this Appendix become unconservative, particularly for cast-in anchors in concrete with compressive strengths in the range of 75 to 85 MPa. Until adequate test results are available, an upper limit on f'_c of 70 MPa has been imposed in the design of cast-in-place anchors. This is consistent with Sec. 6.4 and 8.2. The companion ACI 355.2 does not require testing of post-installed anchors in concrete with f'_c greater than 55 MPa because some post-installed anchors may have difficulty expanding in very high-strength concretes. Because of this, f'_c is limited to 55 MPa in the design of post-installed anchors unless testing is performed.

K.4 General Requirements for Strength of Anchors

K.4.1 Strength design of anchors shall be based either on computation using design models that satisfy the requirements of K.4.2, or on test evaluation using the 5 percent fractile of test results for the following:

- (a) Steel strength of anchor in tension (K.5.1);
- (b) Steel strength of anchor in shear (K.6.1);
- (c) Concrete breakout strength of anchor in tension (K.5.2);
- (d) Concrete breakout strength of anchor in shear (K.6.2);
- (e) Pullout strength of anchor in tension (K.5.3);
- (f) Concrete side-face blowout strength of anchor in tension (K.5.4); and
- (g) Concrete pryout strength of anchor in shear (K.6.3).

Anchors shall also have to satisfy the required edge distances, spacings, and thicknesses to preclude splitting failure, as required in K.8.

Clarification for Section K.4.1: This Section gives the requirements for establishing the strength of anchors to concrete. The various types of steel and concrete failure modes for anchors are shown in Figures K.4.1(a) and K.4.1(b). Comprehensive discussions of anchor failure modes are included in References K.8 to K.10. Any model that complies with the requirements of Sections K.4.2 and K.4.3 can be used to establish the concrete related strengths. For anchors such as headed bolts, headed studs, and post-installed anchors, the concrete breakout design methods of Sections K.5.2 and K.6.2 are acceptable. The anchor strength is also dependent on the pullout strength of Sec K.5.3, the side-face blowout strength of Sec K.5.4, and the minimum spacings and edge distances of Sec K.8. The design of anchors for tension recognizes that the strength of anchors is sensitive to appropriate installation; installation requirements are included in Sec K.9. Some post-installed anchors are less sensitive to installation errors and tolerances. This is reflected in varied ϕ factors based on the assessment criteria of ACI 355.2.

Test procedures can also be used to determine the single anchor breakout strength in tension and in shear. The test results, however, are required to be evaluated on a basis statistically equivalent to that used to select the values for the concrete breakout method “considered to satisfy” provisions of Sec K.4.2. The basic strength cannot be taken greater than the 5 percent fractile. The number of tests has to be sufficient for statistical validity and should be considered in the determination of the 5 percent fractile.

K.4.1.1 Except as required in Sec K.3.3, the design of anchors shall satisfy,

$$\phi N_n \geq N_{ua} \quad (6.K.1)$$

$$\phi V_n \geq V_{ua} \quad (6.K.2)$$

K.4.1.2 In Equations 6.K.1 and 6.K.2, ϕN_n and ϕV_n are the lowest design strengths determined from all appropriate failure modes. ϕN_n is the lowest design strength in tension of an anchor or group of anchors as determined from consideration of ϕN_{sa} , $\phi n N_{pn}$, either ϕN_{sb} or ϕN_{sbg} , and either ϕN_{cb} or ϕN_{cbg} . ϕV_n is the lowest design strength in shear of an anchor or a group of anchors as determined from consideration of: ϕV_{sa} , either ϕV_{sb} or ϕV_{sbg} , and either ϕV_{cb} or ϕV_{cbg} .

K.4.1.3 Interaction effects shall be considered in accordance with Sec K.4.3, when both N_{ua} and V_{ua} are present.

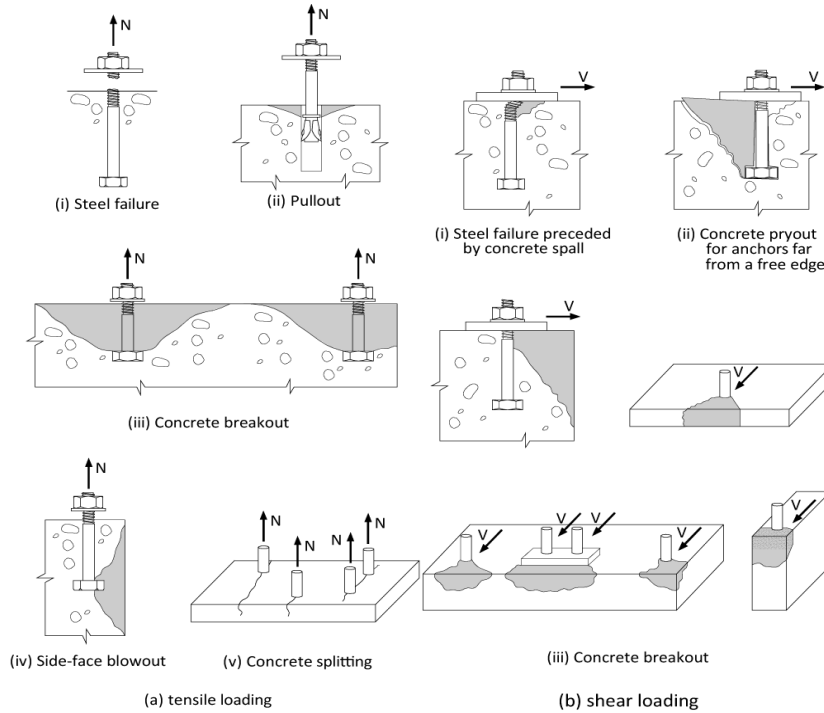


Figure 6.K.2 Failure modes for anchors.

K.4.2 For any anchor or group of anchors, the nominal strength shall be based on design models that result in predictions of strength in substantial agreement with results of comprehensive tests. The materials used in the tests shall be compatible with the materials used in the structure. The nominal strength shall be based on the 5 percent fractile of the basic individual anchor strength. For nominal strengths related to concrete strength, modifications for size effects, the number of anchors, the effects of close spacing of anchors, proximity to edges, depth of the concrete member, eccentric loadings of anchor groups, and presence or absence of cracking shall be taken into account. Limits on edge distances and anchor spacing in the design models shall be consistent with the tests that verified the model.

K.4.2.1 The effect of reinforcement provided to restrain the concrete breakout shall be permitted to be included in the design models used to satisfy Sec K.4.2. Where anchor reinforcement is provided in accordance with Sections K.5.2.9 and K.6.2.9, calculation of the concrete breakout strength in accordance with Sections K.5.2 and K.6.2 is not required.

Clarification for Section K.4.2.1: The addition of reinforcement in the direction of the load to restrain concrete breakout can greatly enhance the strength and deformation capacity of the anchor connection. Such enhancement is practical with cast-in anchors such as those used in precast sections.

References K.8, K.11, K.12, K.13, and K.14 provide information regarding the effect of reinforcement on the behavior of anchors. The effect of reinforcement is not included in the ACI 355.2 anchor acceptance tests or in the concrete breakout calculation method of Sections K.5.2 and K.6.2. The beneficial effect of supplementary reinforcement is recognized by the Condition A ϕ -factors in Sec K.4.4. Anchor reinforcement may be provided instead of calculating breakout strength using the provisions of Sec. 8.2 in conjunction with Sections K.5.2.9 and K.6.2.9.

The breakout strength of an unreinforced connection can be taken as an indication of the load at which significant cracking will occur. Such cracking can represent a serviceability problem if not controlled. (See Clarification for Sec K.6.2.1.)

K.4.2.2 When anchor diameters are not greater than 50 mm, and tensile embedments are not greater than 635 mm in depth, the concrete breakout strength requirements shall be considered satisfied by the design procedure of Sections K.5.2 and K.6.2.

Clarification for Section K.4.2.2: The method for concrete breakout design included as “considered to satisfy” K.4.2 was developed from the Concrete Capacity Design (CCD) Method,^{K.9,K.10} which was an adaptation of the κ Method^{K.15,K.16} and is considered to be accurate, relatively easy to apply, and capable of extension to irregular layouts. The CCD Method predicts the strength of an anchor or group of anchors by using a basic equation for tension, or for shear for a single anchor in cracked concrete, and multiplied by factors that account for the number of anchors, edge distance, spacing, eccentricity, and absence of cracking. The limitations on anchor size and embedment length are based on the current range of test data.

The breakout strength calculations are based on a model suggested in the κ Method. It is consistent with a breakout prism angle of approximately 35° [Figure 6.K.3(a) and (b)].

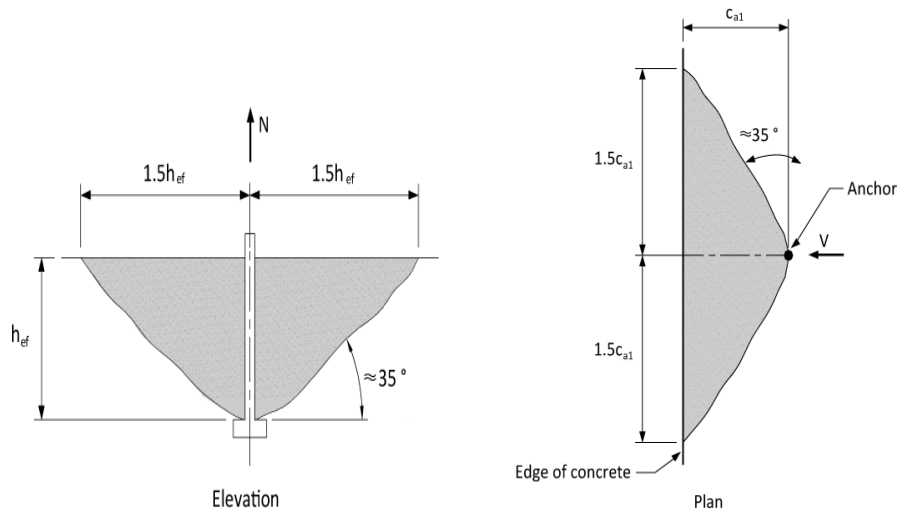


Figure 6.K.3(a) Breakout cone for tension **Figure 6.K.3(b) Breakout cone for shear**

K.4.3 Resistance to combined tensile and shear loads shall be considered in design using an interaction expression that results in computation of strength in substantial agreement with results of comprehensive tests. This requirement shall be considered satisfied by Sec K.7.

Clarification for Sections K.4.2 and K.4.3: Sections K.4.2 and K.4.3 establish the performance factors for which anchor design models are required to be verified. Many possible design approaches exist and the user is always permitted to “design by test” using Sec K.4.2 as long as sufficient data are available to verify the model.

K.4.4 For anchors in concrete, strength reduction factor ϕ shall be as follows when the load combinations of Sec 6.2.2 are used:

- | | |
|---|------|
| (a) When strength of a ductile steel element governs anchor | |
| (i) Tension loads | 0.75 |
| (ii) Shear loads | 0.65 |
| (b) When strength of a brittle steel element governs anchor | |
| (i) Tension loads | 0.65 |
| (ii) Shear loads | 0.60 |

(c) When concrete breakout, side-face blowout, pullout, or pryout strength governs anchor

		Condition A	Condition B
(i)	Shear Loads	0.75	0.70
(ii)	Tension loads		
	Cast-in headed studs, headed bolts, or hooked bolts	0.75	0.70
	Post-installed anchors with category as determined from ACI 355.2		
	Category 1	0.75	0.65
	(Low sensitivity to installation and high reliability)		
	Category 2	0.65	0.55
	(Medium sensitivity to installation and medium reliability)		
	Category 3	0.55	0.45
	(High sensitivity to installation and lower reliability)		

Condition A applies where supplementary reinforcement is present except for pullout and pryout strengths. Condition B applies where supplementary reinforcement is not present, and for pullout or pryout strength.

Clarification for Section K.4.4: The ϕ factors for steel strength are based on using f_{uta} to determine the nominal strength of the anchor (see Sections K.5.1 and K.6.1) rather than f_{ya} as used in the design of reinforced concrete members. Although the ϕ factors for use with f_{uta} appear low, they result in a level of safety consistent with the use of higher ϕ factors applied to f_{ya} . The smaller ϕ factors for shear than for tension do not reflect basic material differences but rather account for the possibility of a non-uniform distribution of shear in connections with multiple anchors. It is acceptable to have a ductile failure of a steel element in the attachment if the attachment is designed so that it will undergo ductile yielding at a load level corresponding to anchor forces no greater than the minimum design strength of the anchors specified in Sec K.3.3. (See Sec K.3.3.5.)

Two conditions are recognized for anchors governed by the more brittle concrete breakout or blowout failure. If supplementary reinforcement is present (Condition A), greater deformation capacity is provided than in the case where such supplementary reinforcement is not present (Condition B). An explicit design of supplementary

reinforcement is not required. However, the arrangement of supplementary reinforcement should generally conform to that of the anchor reinforcement shown in Figures 6.K.7 and 6.K.11(b). Full development is not required. The strength reduction factors for anchor reinforcement are given in Sections 6.K.7 and K.6.2.9.

The ACI 355.2 tests for sensitivity to installation procedures determine the category appropriate for a particular anchoring device. In the ACI 355.2 tests, the effects of variability in anchor torque during installation, tolerance on drilled hole size, energy level used in setting anchors, and for anchors approved for use in cracked concrete, increased crack widths are considered. The three categories of acceptable post-installed anchors are:

Category 1: low sensitivity to installation and high reliability;

Category 2: medium sensitivity to installation and medium reliability; and

Category 3: high sensitivity to installation and lower reliability.

The capacities of anchors under shear loads are not as sensitive to installation errors and tolerances. Therefore, for shear calculations of all anchors, $\phi = 0.75$ for Condition A and $\phi = 0.70$ for Condition B.

K.5 Design Requirements for Tensile Loading

K.5.1 Steel strength of anchor in tension

K.5.1.1 The nominal strength of an anchor in tension as governed by the steel, N_{sa} , shall be evaluated by calculations based on the properties of the anchor material and the physical dimensions of the anchor.

K.5.1.2 The nominal strength of a single anchor or group of anchors in tension, N_{sa} , shall not be greater than

$$N_{sa} = nA_{se,N}f_{uta} \quad (6.K.3)$$

Where, n is the number of anchors in the group, $A_{se,N}$ is the effective cross-sectional area of a single anchor in tension, mm^2 , and f_{uta} shall not be taken greater than the smaller of $1.9f_{ya}$ and 860 MPa.

Clarification for Section K.5.1.2: The nominal strength of anchors in tension is best represented as a function of f_{uta} rather than f_{ya} because the large majority of anchor materials do not exhibit a well-defined yield point. The American Institute of Steel Construction (AISC) has based tension strength of anchors on $A_{se,N}f_{uta}$ since the 1986 edition of their specifications. The use of Eq. 6.K.3 with Sec 6.2.2 load factors and the ϕ -factors of K.4.4 give design strengths consistent with the AISC Load and Resistance Factor Design Specifications.^{K.19}

The limitation of $1.9f_{ya}$ on f_{uta} is to ensure that, under service load conditions, the anchor does not exceed f_{ya} . The limit on f_{uta} of $1.9f_{ya}$ was determined by converting the LRFD provisions to corresponding service level conditions. For Section 6.2.2, the average load factor of 1.4 (from $1.2D + 1.7L$) divided by the highest ϕ -factor (0.75 for tension) results in a limit of f_{uta}/f_{ya} of $1.4/0.75 = 1.87$. The serviceability limitation of f_{uta} was taken as $1.9f_{ya}$. If the ratio of f_{uta} to f_{ya} exceeds this value, the anchoring may be subjected to service loads above f_{ya} under service loads. Although not a concern for standard structural steel anchors (maximum value of f_{uta}/f_{ya} is 1.6 for ASTM A307), the limitation is applicable to some stainless steels. The effective cross-sectional area of an anchor should be provided by the manufacturer of expansion anchors with reduced cross-sectional area for the expansion mechanism. For threaded bolts, ANSI/ASME B1.1^{K.1} defines $A_{se,N}$ as

$$A_{se,N} = \frac{\pi}{4} \left(d_a - \frac{0.9743}{n_t} \right)^2, \text{ Where } n_t \text{ is the number of threads per mm.}$$

K.5.2 Concrete Breakout Strength of Anchor in Tension

K.5.2.1 The nominal concrete breakout strength, N_{cb} or N_{cbg} , of a single anchor or group of anchors in tension shall not exceed

- (a) For a single anchor

$$N_{cb} = \frac{A_{NC}}{A_{NCO}} \psi_{ed,N} \psi_{c,N} \psi_{cp,N} N_b \quad (6.K.4)$$

- (b) For a group of anchors

$$N_{cbg} = \frac{A_{NC}}{A_{NCO}} \psi_{ec,N} \psi_{ed,N} \psi_{c,N} \psi_{cp,N} N_b \quad (6.K.5)$$

Factors $\psi_{ec,N}$, $\psi_{ed,N}$, $\psi_{c,N}$, and $\psi_{cp,N}$ are defined in Sections K.5.2.4, K.5.2.5, K.5.2.6, and K.5.2.7, respectively. A_{NC} is the projected concrete failure area of a single anchor or group of anchors that shall be approximated as the base of the rectilinear geometrical figure that results from projecting the failure surface outward $1.5h_{ef}$ from the centerlines of the anchor, or in the case of a group of anchors, from a line through a row of adjacent anchors. A_{NC} shall not exceed nA_{NCO} , where, n is the number of tensioned anchors in the group. A_{NCO} is the projected concrete failure area of a single anchor with an edge distance equal to or greater than $1.5h_{ef}$.

$$A_{NCO} = 9h_{ef}^2 \quad (6.K.6)$$

Clarification for Section K.5.2.1: The effects of multiple anchors, spacing of anchors, and edge distance on the nominal concrete breakout strength in tension are included by applying the modification factors A_{NC}/A_{NCO} and $\psi_{ed,N}$ in Eq. 6.K.4 and 6.K.5. Figure 6.K.4(a) shows A_{NCO} and the development of Eq. 6.K.6. A_{NCO} is the maximum projected area for a single anchor. Figure 6.K.4(b) shows examples of the projected areas for various single-anchor and multiple-anchor arrangements. Because A_{NC} is the total

projected area for a group of anchors, and A_{NCO} is the area for a single anchor, there is no need to include n , the number of anchors, in Eq. 6.K.4 or 6.K.5. If anchor groups are positioned in such a way that their projected areas overlap, the value of A_{NC} is required to be reduced accordingly.

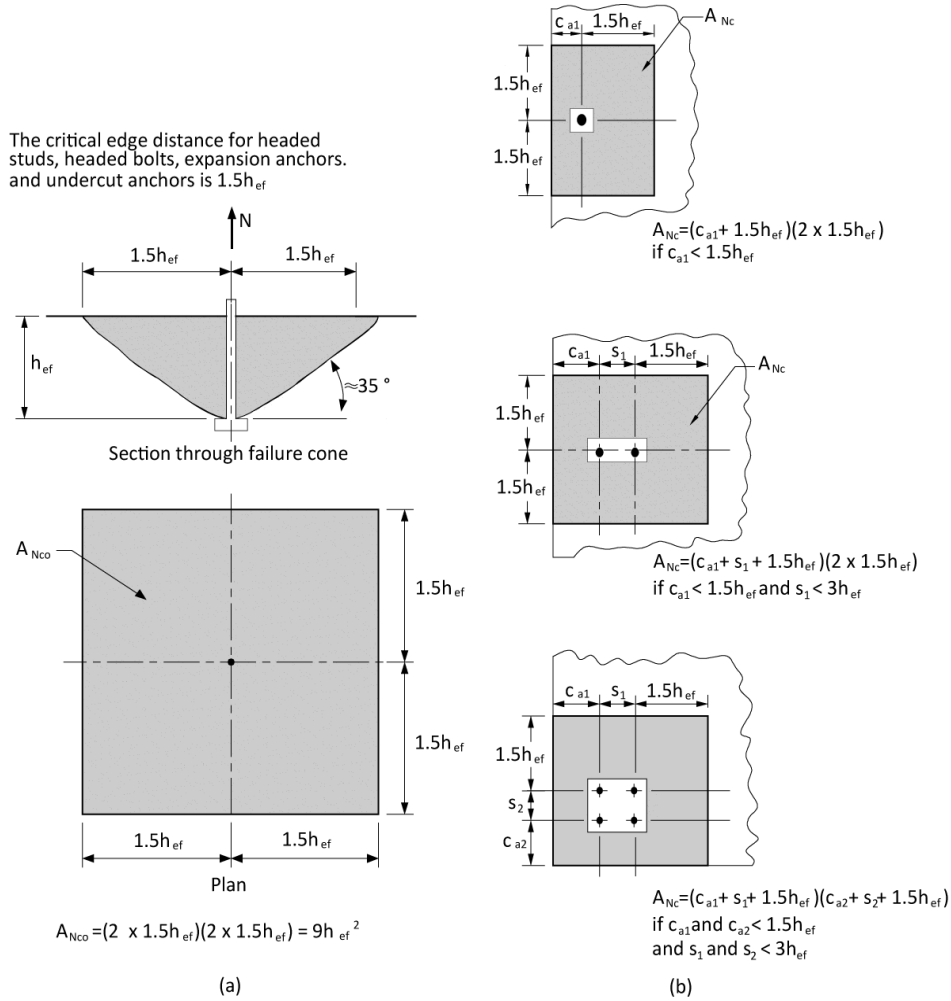


Figure 6.K.4(a) Calculation of A_{NCO} ; and (b) calculation of A_{NC} for single anchors and groups of anchors.

K.5.2.2 The basic concrete breakout strength of a single anchor in tension in cracked concrete, N_b , shall not exceed

$$N_b = k_c \lambda \sqrt{f'_c} (h_{ef})^{1.5} \tag{6.K.7}$$

Where,

$k_c = 10$ for cast-in anchors; and

$k_c = 7$ for post-installed anchors.

The value of k_c for post-installed anchors shall be permitted to be increased above 7 based on ACI 355.2 product-specific tests, but shall in no case exceed 10. Alternatively, for cast-in headed studs and headed bolts with $280\text{ mm} \leq h_{ef} \leq 635\text{ mm}$, N_b shall not exceed

$$N_b = 3.9\lambda\sqrt{f'_c}(h_{ef})^{5/3} \tag{6.K.8}$$

Clarification for Section K.5.2.2: The basic equation for anchor strength was derived^{K.9-K.11, K.16} assuming a concrete failure prism with an angle of about 35°, considering fracture mechanics concepts.

The values of k_c in Eq. 6.K.7 were determined from a large database of test results in uncracked concrete^{K.9} at the 5 percent fractile. The values were adjusted to corresponding k_c values for cracked concrete.^{K.10, K.20} Higher k_c values for post-installed anchors may be permitted, provided they have been determined from product approval testing in accordance with ACI 355.2. For anchors with a deep embedment ($h_{ef} > 280\text{ mm}$) test evidence indicates the use of $(h_{ef})^{1.5}$ can be overly conservative for some cases. Often, such tests have been with selected aggregates for special applications. An alternative expression (Eq. 6.K.8) is provided using $(h_{ef})^{5/3}$ for evaluation of cast-in anchors with $280\text{ mm} \leq h_{ef} \leq 635\text{ mm}$. The limit of 635 mm corresponds to the upper range of test data. This expression can also be appropriate for some undercut post-installed anchors. However, for such anchors, the use of Eq. 6.K.8 should be justified by test results in accordance with Sec K.4.2.

K.5.2.3 If anchors are located less than $1.5h_{ef}$ from three or more edges, the value of h_{ef} used in Eq. 6.K.4 to 6.K.11 shall be the greater of $C_{a,max}/1.5$ and one-third of the maximum spacing between anchors within the group.

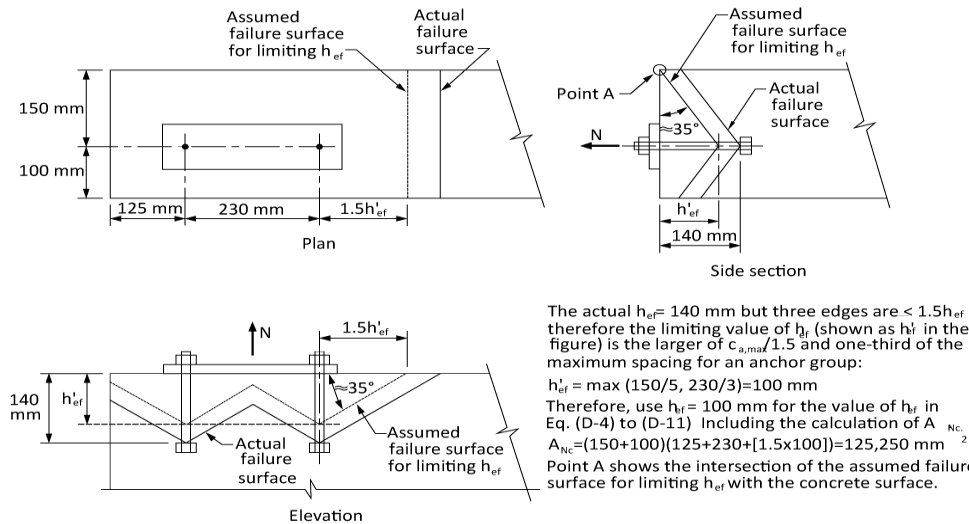


Figure 6.K.5 Tension in narrow members.

Clarification for Section K.5.2.3: For anchors located less than $1.5h_{ef}$ from three or more edges, the tensile breakout strength computed by the CCD Method, which is the basis for Eq. 6.K.4 to 6.K.11, gives overly conservative results.^{K.21} This occurs because the ordinary definitions of A_{Nc}/A_{Nco} do not correctly reflect the edge effects. This problem is corrected by limiting the value of h_{ef} used in Eq. 6.K.4 through 6.K.11 to $C_{a,max}/1.5$, where $C_{a,max}$ is the largest of the influencing edge distances that are less than or equal to the actual $1.5h_{ef}$. In no case should $C_{a,max}/1.5$ be taken less than one-third of the maximum spacing between anchors within the group. The limit on h_{ef} of at least one-third of the maximum spacing between anchors within the group prevents the use of a calculated strength based on individual breakout prisms for a group anchor configuration.

This approach is illustrated in Figure 6.K.5. In this example, the proposed limit on the value of h_{ef} to be used in the computations where, $h_{ef} = C_{a,max}/1.5$, results in $h_{ef} = 100$ mm. For this example, this would be the proper value to be used for h_{ef} in computing the resistance even if the actual embedment depth is larger. The requirement of K.5.2.3 may be visualized by moving the actual concrete breakout surface, which originates at the actual h_{ef} , toward the surface of the concrete parallel to the applied tension load. The value of h_{ef} used in Eq. 6.K.4 to 6.K.11 is determined when either: (a) the outer boundaries of the failure surface first intersect a free edge; or (b) the intersection of the breakout surface between anchors within the group first intersects the surface of the concrete. For the example shown in Figure 6.K.5, Point “A” defines the intersection of the assumed failure surface for limiting h_{ef} with the concrete surface.

K.5.2.4 The modification factor for anchor groups loaded eccentrically in tension, $\psi_{ec,N}$, shall be computed as

$$\psi_{ec,N} = \frac{1}{\left(1 + \frac{2e'_N}{3h_{ef}}\right)} \quad (6.K.9)$$

But, $\psi_{ec,N}$ shall not be taken greater than 1.0. If the loading on an anchor group is such that only some anchors are in tension, only those anchors that are in tension shall be considered when determining the eccentricity e'_N for use in Eq. 6.K.9 and for the calculation of N_{cbg} in Eq. 6.K.5.

In the case where eccentric loading exists about two axes, the modification factor, $\psi_{ec,N}$, shall be computed for each axis individually and the product of these factors used as $\psi_{ec,N}$ in Eq. 6.K.5.

Clarification for Section K.5.2.4: Figure 6.K.6(a) shows a group of anchors that are all in tension but the resultant force is eccentric with respect to the centroid of the anchor group. Groups of anchors can also be loaded in such a way that only some of the anchors are in tension (Figure 6.K.6(b)). In this case, only the anchors in tension are to be considered in the determination of e'_N . The anchor loading has to be determined as the resultant anchor tension at an eccentricity with respect to the center of gravity of the anchors in tension.

K.5.2.5 For single anchors or anchor groups loaded in tension, the modification factor for edge effects, $\psi_{ed,N}$, shall be computed as

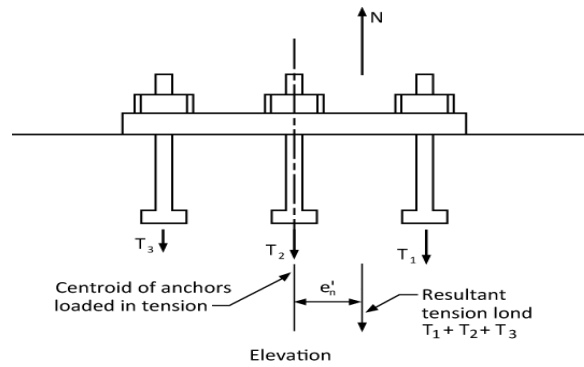
For, $c_{a,\min} \geq 1.5h_{ef}$

$$\psi_{ed,N} = 1.0 \tag{6.K.10}$$

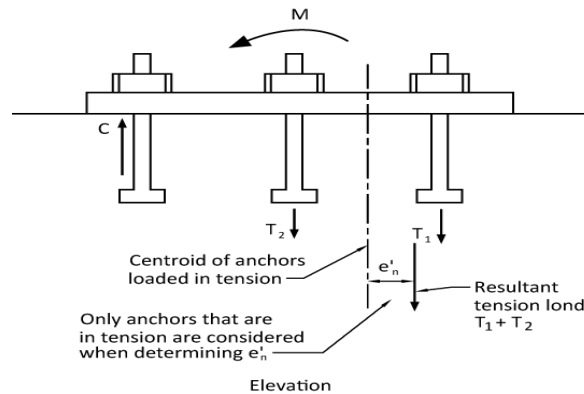
For, $c_{a,\min} < 1.5h_{ef}$

$$\psi_{ed,N} = 0.7 + 0.3 \frac{c_{a,\min}}{1.5h_{ef}} \tag{6.K.11}$$

Clarification for Section K.5.2.5: When anchors are located close to an edge so that there is not enough space for a complete breakout prism to develop, the strength of the anchor is further reduced beyond that reflected in A_{Nc}/A_{Nco} . If the smallest side cover distance is greater than or equal to $1.5h_{ef}$, a complete prism can form and there is no reduction ($\psi_{ec,N} = 1$). If the side cover is less than $1.5h_{ef}$, the factor $\psi_{ed,N}$ is required to adjust for the edge effect.^{K.9}



(a) Where all anchors in a group are in tension



(b) Where only some anchors in a group are in tension

Figure 6.K.6 Definition of e'_N for a group of anchors.

K.5.2.6 When anchors are located in a region of a concrete member where analysis indicates no cracking at service load levels, the following modification factor shall be permitted:

$\psi_{c,N} = 1.25$ for cast-in anchors; and

$\psi_{c,N} = 1.4$ for post-installed anchors, where the value of k_c used in Eq. 6.K.7 is 7.

Where the value of k_c used in Eq. 6.K.7 is taken from the ACI 355.2 product evaluation report for post-installed anchors qualified for use in both cracked and uncracked concrete, the values of k_c and $\psi_{c,N}$ shall be based on the ACI 355.2 product evaluation report.

Where the value of k_c used in Eq. 6.K.7 is taken from the ACI 355.2 product evaluation report for post-installed anchors qualified for use in uncracked concrete, $\psi_{c,N}$ shall be taken as 1.0.

When analysis indicates cracking at service load levels, $\psi_{c,N}$ shall be taken as 1.0 for both cast-in anchors and post-installed anchors. Post-installed anchors shall be qualified for use in cracked concrete in accordance with ACI 355.2. The cracking in the concrete shall be controlled by flexural reinforcement distributed in accordance with 10.6.4, or equivalent crack control shall be provided by confining reinforcement.

Clarification for Section K.5.2.6: Post-installed and cast-in anchors that have not met the requirements for use in cracked concrete according to ACI 355.2 should be used in uncracked regions only. The analysis for the determination of crack formation should include the effects of restrained shrinkage (see Sec. 8.1). The anchor qualification tests of ACI 355.2 require that anchors in cracked concrete zones perform well in a crack that is 0.3 mm wide. If wider cracks are expected, confining reinforcement to control the crack width to about 0.3 mm should be provided.

The concrete breakout strengths given by Eq. 6.K.7 and 6.K.8 assume cracked concrete (that is, $\psi_{c,N} = 1.0$) with $\psi_{c,N}k_c = 10 = 10$ for cast-in-place, and 7 for post-installed (cast-in 40 percent higher). When the uncracked concrete $\psi_{c,N}$ factors are applied (1.25 for cast-in, and 1.4 for post-installed), the results are $\psi_{c,N}k_c$ factors of 13 for cast-in and 10 for post-installed (25 percent higher for cast-in). This agrees with field observations and tests that show cast-in anchor strength exceeds that of post-installed for both cracked and uncracked concrete.

K.5.2.7 The modification factor for post-installed anchors designed for uncracked concrete in accordance with Sec K.5.2.6 without supplementary reinforcement to control splitting, $\psi_{cp,N}$, shall be computed as follows using the critical distance c_{ac} as defined in Sec K.8.6.

For, $c_{a,min} \geq c_{ac}$

$$\psi_{cp,N} = 1.0 \quad (6.K.12)$$

For, $c_{a,min} < c_{ac}$

$$\psi_{cp,N} = \frac{c_{a,min}}{c_{ac}} \quad (6.K.13)$$

But $\psi_{cp,N}$ determined from Eq. 6.K.13 shall not be taken less than $1.5h_{ef}/C_{ac}$, where the critical distance C_{ac} is defined in Sec K.8.6. For all other cases, including cast-in anchors, $\psi_{cp,N}$ shall be taken as 1.0.

Clarification for Section K.5.2.7: The design provisions in K.5 are based on the assumption that the basic concrete breakout strength can be achieved if the minimum edge distance, $C_{a,min}$, equals $1.5h_{ef}$. However, test results^{K.22} indicate that many torque-controlled and displacement-controlled expansion anchors and some undercut anchors require minimum edge distances exceeding $1.5h_{ef}$ to achieve the basic concrete breakout strength when tested in uncracked concrete without supplementary reinforcement to control splitting. When a tension load is applied, the resulting tensile stresses at the embedded end of the anchor are added to the tensile stresses induced due to anchor installation, and splitting failure may occur before reaching the concrete breakout strength defined in Sec K.5.2.1. To account for this potential splitting mode of failure, the basic concrete breakout strength is reduced by a factor $\psi_{cp,N}$ if $C_{a,min}$ is less than the critical edge distance C_{ac} . If supplementary reinforcement to control splitting is present or if the anchors are located in a region where analysis indicates cracking of the concrete at service loads, then the reduction factor $\psi_{cp,N}$ is taken as 1.0. The presence of supplementary reinforcement to control splitting does not affect the selection of Condition A or B in Sec K.4.4.

K.5.2.8 Where an additional plate or washer is added at the head of the anchor, it shall be permitted to calculate the projected area of the failure surface by projecting the failure surface outward $1.5h_{ef}$ from the effective perimeter of the plate or washer. The effective perimeter shall not exceed the value at a section projected outward more than the thickness of the washer or plate from the outer edge of the head of the anchor.

K.5.2.9 Where anchor reinforcement is developed in accordance with Sec. 8.3 on both sides of the breakout surface, the design strength of the anchor reinforcement shall be permitted to be used instead of the concrete breakout strength in determining ϕN_n . A strength reduction factor of 0.75 shall be used in the design of the anchor reinforcement.

Clarification for Section K.5.2.9: For conditions where the factored tensile force exceeds the concrete breakout strength of the anchor(s) or where the breakout strength is not evaluated, the nominal strength can be that of anchor reinforcement properly anchored as illustrated in Figure 6.K.7. Care needs to be taken in the selection and positioning of the anchor reinforcement. The anchor reinforcement should consist of stirrups, ties, or hairpins placed as close as practicable to the anchor. Only reinforcement spaced less than $0.5h_{ef}$ from the anchor centerline should be included as anchor reinforcement. The research^{K.14} on which these provisions is based was limited to anchor reinforcement with maximum diameter similar to a No. 16 bar. It is beneficial for the anchor reinforcement to enclose the surface reinforcement. In sizing the anchor reinforcement, use of a 0.75 strength reduction factor ϕ is recommended as is used for strut-and-tie models. As a practical matter, use of anchor reinforcement is generally limited to cast-in-place anchors.

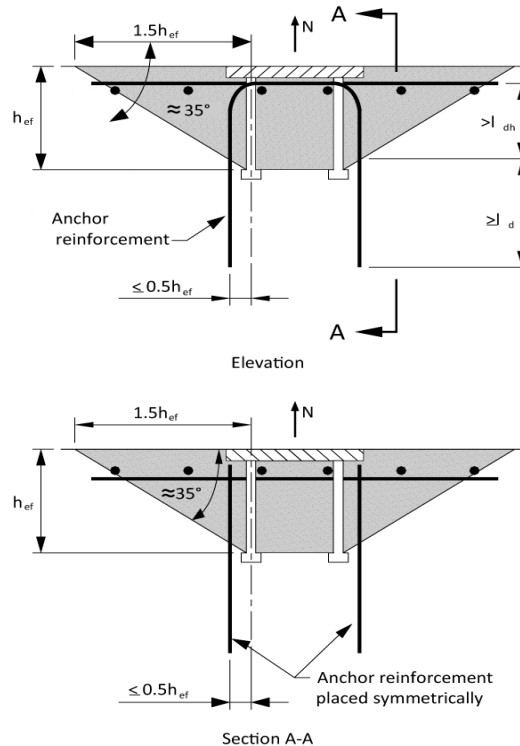


Figure 6.K.7 Anchor reinforcement for tension.

K.5.3 Pullout Strength of Anchor in Tension

K.5.3.1 The nominal pullout strength of a single anchor in tension, N_{pn} , shall not exceed

$$N_{pn} = \psi_{c,p} N_p \quad (6.K.14)$$

Where, $\psi_{c,p}$ is defined in K.5.3.6.

K.5.3.2 The values of N_p for post-installed expansion and undercut anchors shall be based on the 5 percent fractile of results of tests performed and evaluated according to ACI 355.2. It is not permissible to calculate the pullout strength in tension for such anchors.

Clarification for Section K.5.3.2: The pullout strength equations given in Sections K.5.3.4 and K.5.3.5 are only applicable to cast-in headed and hooked anchors;^{K.8.K.23} they are not applicable to expansion and undercut anchors that use various mechanisms for end anchorage unless the validity of the pullout strength equations are verified by tests.

K.5.3.3 It shall be permitted to evaluate the pullout strength in tension for single cast-in headed studs and headed bolts using Sec K.5.3.4. For single J- or L-bolts, it shall be permitted to evaluate the pullout strength in tension using K.5.3.5. Alternatively, it shall be permitted to use values of N_p based on the 5 percent fractile of tests performed and evaluated in the same manner as the ACI 355.2 procedures but without the benefit of friction.

Clarification for Section K.5.3.3: The pullout strength in tension of headed studs or headed bolts can be increased by providing confining reinforcement, such as closely spaced spirals, throughout the head region. This increase can be demonstrated by tests.

K.5.3.4 For a single headed stud or headed bolt, the pullout strength in tension, N_p , for use in Eq. 6.K.14, shall not exceed

$$N_p = 8A_{brg}f'_c \quad (6.K.15)$$

Clarification for K.5.3.4: The value computed from Eq. 6.K.15 corresponds to the load at which crushing of the concrete occurs due to bearing of the anchor head.^{K.8.K.13} It is not the load required to pull the anchor completely out of the concrete, so the equation contains no term relating to embedment depth. Local crushing of the concrete greatly reduces the stiffness of the connection, and generally will be the beginning of a pullout failure.

K.5.3.5 For a single hooked bolt, the pullout strength in tension, N_p , for use in Eq. 6.K.14 shall not exceed

$$N_p = 0.9f'_c e_h d_a \quad (6.K.16)$$

Where, $3d_a \leq e_h \leq 4.5d_a$

Clarification for Section K.5.3.5: Eq. 6.K.16 for hooked bolts was developed by Lutz based on the results of Reference K.23. Reliance is placed on the bearing component only, neglecting any frictional component because crushing inside the hook will greatly reduce the stiffness of the connection, and generally will be the beginning of pullout failure. The limits on e_h are based on the range of variables used in the three tests programs reported in Reference K.23.

K.5.3.6 When an anchor is located in a region of a concrete member where analysis indicates no cracking at service load levels, the following modification factor shall be permitted $\psi_{c,p} = 1.4$ Where analysis indicates cracking at service load levels, $\psi_{c,p}$ shall be taken as 1.0.

K.5.4 Concrete Side-Face Blowout Strength of a Headed Anchor in Tension

Clarification for Section K.5.4: Concrete side-face blowout strength of a headed anchor in tension. For side-face blowout, the design requirements are based on the recommendations of Reference K.24. These requirements are applicable to headed anchors that usually are cast-in anchors. Splitting during installation rather than side-face blowout generally governs post-installed anchors, and is evaluated by the ACI 355.2 requirements.

K.5.4.1 With deep embedment close to an edge ($h_{ef} > 2.5c_{a1}$), the nominal side-face blowout strength, $h_{ef} > N_{sb}$, of a single headed anchor shall not exceed

$$N_{sb} = (13c_{a1}\sqrt{A_{brg}})\lambda\sqrt{f'_c} \quad (6.K.17)$$

If c_{a2} for the single headed anchor is less than $3c_{a1}$, the value of N_{sb} shall be multiplied by the factor $\frac{1+\frac{c_{a2}}{c_{a1}}}{4}$, where, $1.0 \leq c_{a2}/c_{a1} \leq 3.0$.

K.5.4.2 For multiple headed anchors with deep embedment close to an edge ($h_{ef} > 2.5hc_{a1}$) and anchor spacing less than $6c_{a1}$, the nominal strength of those anchors susceptible to a side-face blowout failure N_{sbg} shall not exceed

$$N_{sbg} = \left(1 + \frac{s}{6c_{a1}}\right)N_{sb} \quad (6.K.18)$$

Where, s is the distance between the outer anchors along the edge, and N_{sb} is obtained from Eq. 6.K.17 without modification for a perpendicular edge distance.

Clarification for Section K.5.4.2: Only those anchors close to an edge ($h_{ef} > 2.5c_{a1}$), that are loaded in tension should be considered when determining nominal side-face blowout strength for multiple headed anchors. Their strength should be compared to the proportion of the tensile load applied to those anchors.

K.6 Design Requirements for Shear Loading

K.6.1 Steel Strength of Anchor in Shear

K.6.1.1 For an anchor in shear, the nominal strength governed by steel, V_{sa} , shall be evaluated by calculations based on the properties of the anchor material and the physical dimensions of the anchor.

K.6.1.2 For a single anchor or group of anchors in shear, the nominal strength, V_{sa} , shall not exceed (a) to (c):

(a) For cast-in headed stud anchor

$$V_{sa} = nA_{se,V}f_{uta} \quad (6.K.19)$$

Where, n is the number of anchors in the group, $A_{se,V}$ is the effective cross-sectional area of a single anchor in shear, mm^2 , and f_{uta} shall not be taken greater than the smaller of $1.9f_{ya}$ and 860 MPa.

(b) For cast-in headed bolt and hooked bolt anchors and for post-installed anchors where sleeves do not extend through the shear plane

$$V_{sa} = 0.6nA_{se,V}f_{uta} \quad (6.K.20)$$

Where, n is the number of anchors in the group, $A_{se,V}$ is the effective cross-sectional area of a single anchor in shear, mm^2 , and f_{uta} shall not be taken greater than the smaller of $1.9f_{ya}$ and 860 MPa.

(c) For post-installed anchors where sleeves extend through the shear plane, V_{sa} shall be based on the results of tests performed and evaluated according to ACI 355.2. Alternatively, Eq. 6.K.20 shall be permitted to be used.

Clarification for Section K.6.1.2: The nominal shear strength of anchors is best represented as a function of f_{uta} rather than f_{ya} because the large majority of anchor materials do not exhibit a well-defined yield point. Welded studs develop a higher steel shear strength than headed anchors due to the fixity provided by the weld between the studs and the base plate. The use of Eq. 6.K.19 and 6.K.20 with 6.2.2 load factors and the ϕ -factors of K.4.4 give design strengths consistent with the AISC Load and Resistance Factor Design Specifications.^{K.19}

The limitation of $1.9f_{ya}$ on f_{uta} is to ensure that, under service load conditions, the anchor stress does not exceed f_{ya} . The limit on f_{uta} of $1.9f_{ya}$ was determined by converting the LRFD provisions to corresponding service level conditions as discussed in Clarification for K.5.1.2.

The effective cross-sectional area of an anchor should be provided by the manufacturer of expansion anchors with reduced cross-sectional area for the expansion mechanism. For threaded bolts, ANSI/ASME B1.1^{K.1} defines $A_{se,V}$ as

$$A_{se,V} = \frac{\pi}{4} \left(d_a - \frac{0.9743}{n_i} \right)^2$$

Where, n_t is the number of threads per mm.

K.6.1.3 Where anchors are used with built-up grout pads, the nominal strengths of Sec K.6.1.2 shall be multiplied by a 0.80 factor.

K.6.2 Concrete Breakout Strength of Anchor in Shear

K.6.2.1 The nominal concrete breakout strength, V_{cb} or V_{cbg} , in shear of a single anchor or group of anchors shall not exceed:

- (a) For shear force perpendicular to the edge on a single anchor

$$V_{cb} = \frac{A_{vc}}{A_{vco}} \psi_{ed,V} \psi_{c,V} \psi_{h,V} V_b \quad (6.K.21)$$

- (b) For shear force perpendicular to the edge on a group of anchors

$$V_{cbg} = \frac{A_{vc}}{A_{vco}} \psi_{ec,V} \psi_{ed,V} \psi_{c,V} \psi_{h,V} V_b \quad (6.K.22)$$

- (c) For shear force parallel to an edge, V_{cb} or V_{cbg} shall be permitted to be twice the value of the shear force determined from Eq. 6.K.21 or 6.K.22, respectively, with the shear force assumed to act perpendicular to the edge and with $\psi_{ed,V}$ taken equal to 1.0.
- (d) For anchors located at a corner, the limiting nominal concrete breakout strength shall be determined for each edge, and the minimum value shall be used.

Factors $\psi_{ec,V}$, $\psi_{ed,V}$, $\psi_{c,V}$, and $\psi_{h,V}$ are defined in Sections K.6.2.5, K.6.2.6, K.6.2.7, and K.6.2.8, respectively. V_b is the basic concrete breakout strength value for a single anchor. A_{vc} is the projected area of the failure surface on the side of the concrete member at its edge for a single anchor or a group of anchors. It shall be permitted to evaluate A_{vc} as the base of a truncated half pyramid projected on the side face of the member where the top of the half pyramid is given by the axis of the anchor row selected as critical. The value of c_{a1} shall be taken as the distance from the edge to this axis. A_{vc} shall not exceed nA_{vco} , where n is the number of anchors in the group.

A_{vco} is the projected area for a single anchor in a deep member with a distance from edges equal or greater than $1.5c_{a1}$ in the direction perpendicular to the shear force. It shall be permitted to evaluate A_{vco} as the base of a half pyramid with a side length parallel to the edge of $3c_{a1}$ and a depth of $1.5c_{a1}$

$$A_{vco} = 4.5(c_{a1})^2 \quad (6.K.23)$$

Where anchors are located at varying distances from the edge and the anchors are welded to the attachment so as to distribute the force to all anchors, it shall be permitted to evaluate the strength based on the distance to the farthest row of anchors from the edge. In this case, it shall be permitted to base the value of c_{d1} on the distance from the edge to the axis of the farthest anchor row that is selected as critical, and all of the shear shall be assumed to be carried by this critical anchor row alone.

Clarification for Section K.6.2.1: The shear strength equations were developed from the CCD Method. They assume a breakout cone angle of approximately 35° (see Figure 6.K.3(b)), and consider fracture mechanics theory. The effects of multiple anchors, spacing of anchors, edge distance, and thickness of the concrete member on nominal concrete breakout strength in shear are included by applying the reduction factor of A_{vc}/A_{vco} in Eq. 6.K.21 and 6.K.22, and $\psi_{ec,V}$ in Eq. 6.K.22. For anchors far from the edge, Sec K.6.2 usually will not govern. For these cases, Sections K.6.1 and K.6.3 often govern.

Figure 6.K.8(a) shows A_{vco} and the development of Eq. 6.K.23. A_{vco} is the maximum projected area for a single anchor that approximates the surface area of the full breakout prism or cone for an anchor unaffected by edge distance, spacing, or depth of member. Figure 6.K.8(b) shows examples of the projected areas for various single-anchor and multiple-anchor arrangements. A_{vc} approximates the full surface area of the breakout cone for the particular arrangement of anchors. Because A_{vc} is the total projected area for a group of anchors, and A_{vco} is the area for a single anchor, there is no need to include the number of anchors in the equation.

When using Eq. 6.K.22 for anchor groups loaded in shear, both assumptions for load distribution illustrated in examples on the right side of Figure 6.K.8(b) should be considered because the anchors nearest the edge could fail first or the whole group could fail as a unit with the failure surface originating from the anchors farthest from the edge. If the anchors are welded to a common plate, when the anchor nearest the front edge begins to form a failure cone, shear load would be transferred to the stiffer and stronger rear anchor. For this reason, anchors welded to a common plate do not need to consider the failure mode shown in the upper right figure of Figure 6.K.8(b). The PCI Design Handbook approach^{K.18} suggests in Sec 6.5.2.2 that the strength of the anchors away from the edge be considered. Because this is a reasonable approach, assuming that the anchors are spaced far enough apart so that the shear failure surfaces do not intersect,^{K.11} Sec K.6.2 allows such a procedure. If the failure surfaces do not intersect, as would generally occur if the anchor spacing s is equal to or greater than $1.5c_{d1}$, then after

formation of the near-edge failure surface, the higher strength of the farther anchor would resist most of the load. As shown in the bottom right example in Figure 6.K.8(b), it would be appropriate to consider the shear strength to be provided entirely by this anchor with its much larger resisting failure surface. No contribution of the anchor near the edge is then considered. Checking the near-edge anchor condition is advisable to preclude undesirable cracking at service load conditions. Further discussion of design for multiple anchors is given in Reference K.8.

For the case of anchors near a corner subjected to a shear force with components normal to each edge, a satisfactory solution is to check independently the connection for each component of the shear force. Other specialized cases, such as the shear resistance of anchor groups where all anchors do not have the same edge distance, are treated in Reference K.11.

The detailed provisions of 6.K.8(a) apply to the case of shear force directed toward an edge. When the shear force is directed away from the edge, the strength will usually be governed by Sec K.6.1 or Sec K.6.3.

The case of shear force parallel to an edge is shown in Figure 6.K.8(c). A special case can arise with shear force parallel to the edge near a corner. In the example of a single anchor near a corner (see Figure 6.K.8(d)), the provisions for shear force applied perpendicular to the edge should be checked in addition to the provisions for shear force applied parallel to the edge.

K.6.2.2 For a single anchor in cracked concrete, the basic concrete breakout strength in shear, V_b shall not exceed

$$V_b = 0.6 \left(\frac{l_e}{d_a} \right)^{0.2} \sqrt{d_a} \lambda \sqrt{f'_c} (c_{a1})^{1.5} \quad (6.K.24)$$

Where, l_e is the load-bearing length of the anchor for shear ($l_e = h_{ef}$) for anchors with a constant stiffness over the full length of embedded section, such as headed studs and post-installed anchors with one tubular shell over full length of the embedment depth, $l_e = 2d_a$ for torque-controlled expansion anchors with a distance sleeve separated from expansion sleeve, and $l_e \leq 8d_a$ in all cases.

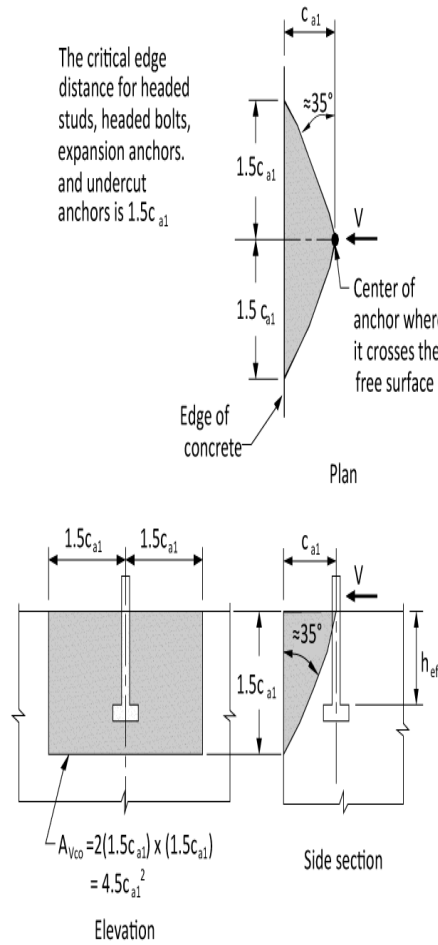


Figure 6.K.8 (a) Calculation of A_{vco} .

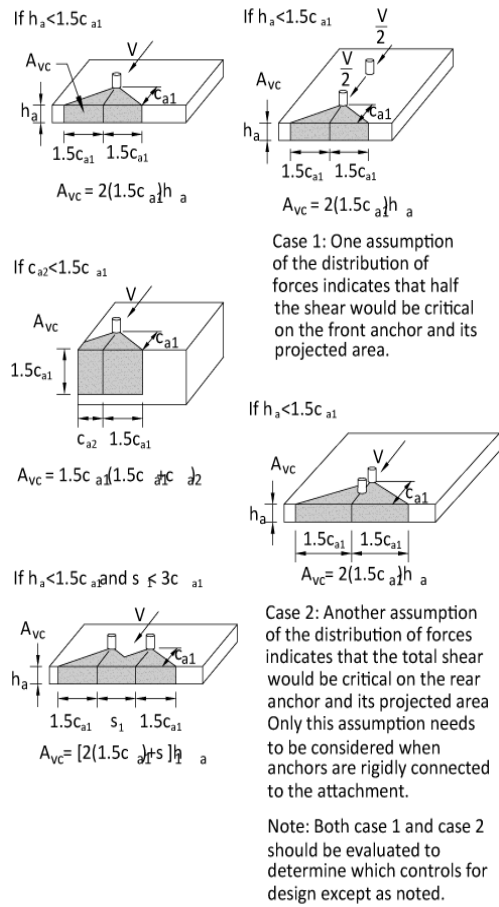


Figure 6.K.8 (b) Calculation of A_{vc} for single anchors and groups of anchors.

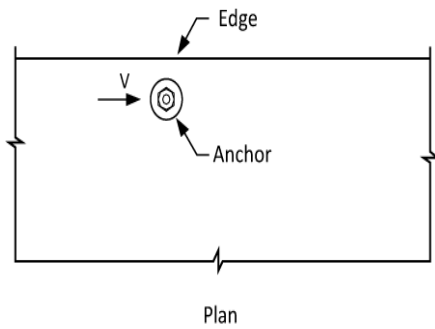


Figure 6.K.8(c) Shear force parallel to an edge.

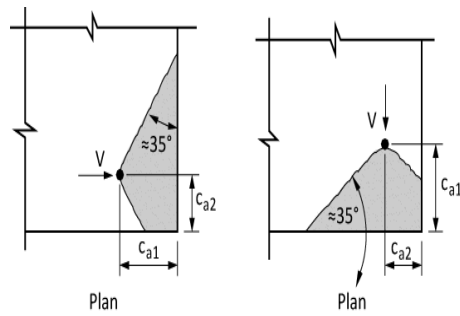
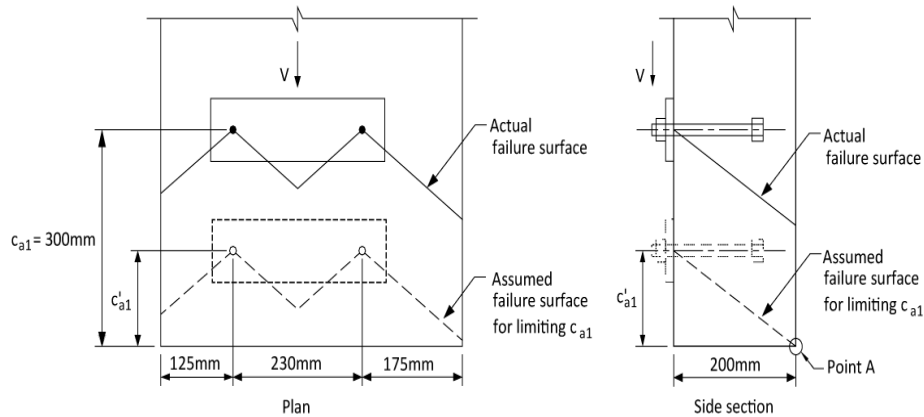


Figure 6.K.8(d) Shear force near a corner.



The actual $c_{a1} = 300\text{mm}$ but two orthogonal edges c_{a2} and h_a are $< 1.5c$ therefore the limiting value of c_{a1} (shown as c'_{a1} in the figure) is the larger of $c_{a2, \text{max}}/1.5$, $h_a/1.5$ and one-third of the maximum spacing for an anchor group:

$$c'_{a1} = \max(175/1.5, 200/1.5, 230/3) = 133\text{mm}$$

Therefore, use $c'_{a1} = 133\text{mm}$ in Eq. (D-21) to (D-28) including the calculation of A_{vc} :

$$A_{vc} = (125+230+175)(1.5 \times 133) = 105,735\text{mm}^2$$

Point a shows the intersection of the assumed failure surface for limiting c_{a1} with the concrete surface.

Figure 6.K.9 Shear when anchors are influenced by three or more edges.

Clarification for Section K.6.2.2: Like the concrete breakout tensile strength, the concrete breakout shear strength does not increase with the failure surface, which is proportional to $(C_{a1})^2$. Instead, the strength increases proportionally to $(C_{a1})^{1.5}$ due to size effect. The strength is also influenced by the anchor stiffness and the anchor diameter.^{K.9-K.11, K.16}

The constant, 0.6, in the shear strength equation was determined from test data reported in Reference K.9 at the 5 percent fractile adjusted for cracking.

K.6.2.3 For cast-in headed studs, headed bolts, or hooked bolts that are continuously welded to steel attachments having a minimum thickness equal to the greater of 10 mm and half of the anchor diameter, the basic concrete breakout strength in shear of a single anchor in cracked concrete, V_b , shall not exceed

$$V_b = 0.66 \left(\frac{I_e}{d_a} \right)^{0.2} \sqrt{d_a} \lambda \sqrt{f'_c} (c_{a1})^{1.5} \quad (6.K.25)$$

Where, I_e is defined in Sec K.6.2.2, provided that:

- for groups of anchors, the strength is determined based on the strength of the row of anchors farthest from the edge;
- anchor spacing, s , is not less than 65 mm; and
- reinforcement is provided at the corners if $C_{a2} \leq 1.5h_{ef}$.

Clarification for Section K.6.2.3: For the case of cast-in headed bolts continuously welded to an attachment, test data^{K.25} show that somewhat higher shear strength exists, possibly due to the stiff welding connection clamping the bolt more effectively than an attachment with an anchor gap. Because of this, the basic shear value for such anchors is increased. Limits are imposed to ensure sufficient rigidity. The design of supplementary reinforcement is discussed in References K.8, K.11, and K.12.

K.6.2.4 If anchors are influenced by three or more edges, the value of C_{a1} used in Eq. 6.K.23 to 6.K.29 shall not exceed the greatest of: $C_{a2}/1.5$ in either direction, $h_a/1.5$; and one-third of the maximum spacing between anchors within the group.

Clarification for Section K.6.2.4: If anchors are influenced by three or more edges where any edge distance is less than $1.5C_{a1}$, the shear breakout strength computed by the basic CCD Method, which is the basis for Equations 6.K.21 to 6.K.29, gives safe but overly conservative results. These cases were studied for the κ Method^{K.16} and the problem was pointed out by Lutz.^{K.21} Similarly, the approach used for tensile breakouts in Sec K.5.2.3, strength is correctly evaluated if the value of c_{a1} used in Equations 6.K.21 to 6.K.29 is limited to the maximum of $C_{a2}/1.5$ in each direction, $h_a/1.5$, and one-third of the maximum spacing between anchors within the group. The limit on c_{a1} of at least one-third of the maximum spacing between anchors within the group prevents the use of a calculated strength based on individual breakout prisms for a group anchor configuration.

This approach is illustrated in Figure 6.K.9. In this example, the limit on the value of c_{a1} is the largest of $C_{a2}/1.5$ in either direction, $h_a/1.5$, and one-third the maximum spacing between anchors for anchor groups results in $C_{a1} = 133$ mm. For this example, this would be the proper value to be used for C_{a1} in computing V_{cb} or V_{cbg} , even if the actual edge distance that the shear is directed toward is larger. The requirement of Sec K.6.2.4 may be visualized by moving the actual concrete breakout surface originating at the actual c_{a1} toward the surface of the concrete in the direction of the applied shear load. The value of C_{a1} used in Equations 6.K.21 to 6.K.29 is determined when either: (a) the outer boundaries of the failure surface first intersect a free edge; or (b) the intersection of the breakout surface between anchors within the group first intersects the surface of the concrete. For the example shown in Figure 6.K.9, Point “A” shows the intersection of the assumed failure surface for limiting C_{a1} with the concrete surface.

K.6.2.5 The modification factor for anchor groups loaded eccentrically in shear, $\psi_{ec,V}$, shall be computed as

$$\psi_{ec,V} = \frac{1}{\left(1 + \frac{2e'_V}{3c_{a1}}\right)} \quad (6.K.26)$$

But $\psi_{ec,V}$ shall not be taken greater than 1.0.

If the loading on an anchor group is such that only some anchors are loaded in shear in the same direction, only those anchors that are loaded in shear in the same direction shall be considered when determining the eccentricity of e'_v for use in Eq. 6.K.26 and for the calculation of V_{cbg} in Eq. 6.K.22.

Clarification for Section K.6.2.5: This section provides a modification factor for an eccentric shear force toward an edge on a group of anchors. If the shear force originates above the plane of the concrete surface, the shear should first be resolved as a shear in the plane of the concrete surface, with a moment that may or may not also cause tension in the anchors, depending on the normal force. Figure 6.K.10 defines the term e'_v for calculating the $\psi_{ec,V}$ modification factor that accounts for the fact that more shear is applied to one anchor than others, tending to split the concrete near an edge.

K.6.2.6 The modification factor for edge effect for a single anchor or group of anchors loaded in shear, $\psi_{ed,V}$, shall be computed as

For, $c_{a2} \geq 1.5c_{a1}$

$$\psi_{ed,V} = 1.0 \quad (6.K.27)$$

For, $c_{a2} < 1.5c_{a1}$

$$\psi_{ed,V} = 0.7 + 0.3 \frac{c_{a2}}{1.5c_{a1}} \quad (6.K.28)$$

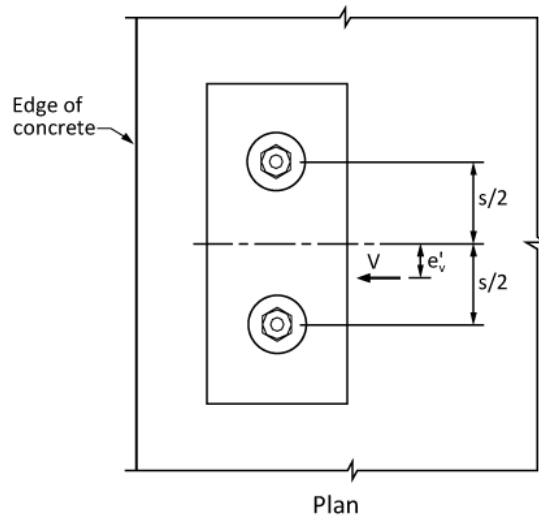


Figure 6.K.10 Definition of e'_v for a group of anchors.

K.6.2.7 For anchors located in a region of a concrete member where analysis indicates no cracking at service loads, the modification factor shall be permitted as $\psi_{c,V} = 1.4$.

For anchors located in a region of a concrete member where analysis indicates cracking at service load levels, the following modification factors shall be permitted:

$\psi_{c,V} = 1.0$ for anchors in cracked concrete with no supplementary reinforcement or edge reinforcement smaller than a No. 13 bar;

$\psi_{c,V} = 1.2$ for anchors in cracked concrete with reinforcement of a No. 13 bar or greater between the anchor and the edge; and

$\psi_{c,V} = 1.4$ for anchors in cracked concrete with reinforcement of a No. 13 bar or greater between the anchor and the edge, and with the reinforcement enclosed within stirrups spaced at not more than 100 mm.

Clarification for Section K.6.2.7: Torque-controlled and displacement-controlled expansion anchors are permitted in cracked concrete under pure shear loadings.

K.6.2.8 The modification factor for anchors located in a concrete member where $h_a < 1.5C_{a1}$, $\psi_{h,V}$ shall be computed as

$$\psi_{h,V} = \sqrt{\frac{1.5c_{a1}}{h_a}} \quad (6.K.29)$$

But, $\psi_{h,V}$ shall not be taken less than 1.0.

Clarification for Section K.6.2.8: For anchors located in a concrete member where, $h_a < 1.5C_{a1}$ tests^{K.8.K.14} have shown that the concrete breakout strength in shear is not directly proportional to the member thickness h_a . The factor $\psi_{h,V}$ accounts for this effect.

K.6.2.9 Where anchor reinforcement is either developed in accordance with Sec 8.2 on both sides of the breakout surface, or encloses the anchor and is developed beyond the breakout surface, the design strength of the anchor reinforcement shall be permitted to be used instead of the concrete breakout strength in determining ϕV_n . A strength reduction factor of 0.75 shall be used in the design of the anchor reinforcement.

Clarification for Section K.6.2.9: For conditions where the factored shear force exceeds the concrete breakout strength of the anchor(s) in shear, or where the breakout strength is not evaluated, the nominal strength can be that of anchor reinforcement properly anchored as shown in Figure 6.K.11(a) and (b). To ensure yielding of the anchor reinforcement, the enclosing anchor reinforcement in Figure 6.K.11(a) should be in contact with the anchor and placed as close as practicable to the concrete surface. The research^{K.14} on which the provisions for enclosing reinforcement (see Figure 6.K.11(a)) are based was limited to anchor reinforcement with maximum diameter similar to a No. 16 bar. The larger bend radii associated with larger bar diameters may significantly reduce the effectiveness of the anchor reinforcement, and therefore anchor reinforcement with a diameter larger than No. 19 is not recommended.

The reinforcement could also consist of stirrups and ties (as well as hairpins) enclosing the edge reinforcement embedded in the breakout cone and placed as close to the anchors as practicable (see Figure 6.K.11(b)). Only reinforcement spaced less than the lesser of $0.5c_{a1}$ and $0.3c_{a2}$ from the anchor centerline should be included as anchor reinforcement. In this case, the anchor reinforcement must be developed on both sides of the breakout surface. For equilibrium reasons, an edge reinforcement must be present. The research on which these provisions are based was limited to anchor reinforcement with maximum diameter similar to a No. 19 bar.

Because the anchor reinforcement is placed below where the shear is applied (see Figure 6.K.11(b)), the force in the anchor reinforcement will be larger than the shear force. In sizing the anchor reinforcement, use of a 0.75 strength reduction factor ϕ is recommended as used for shear and for strut-and-tie models. As a practical matter, the use of anchor reinforcement is generally limited to cast-in-place anchors.

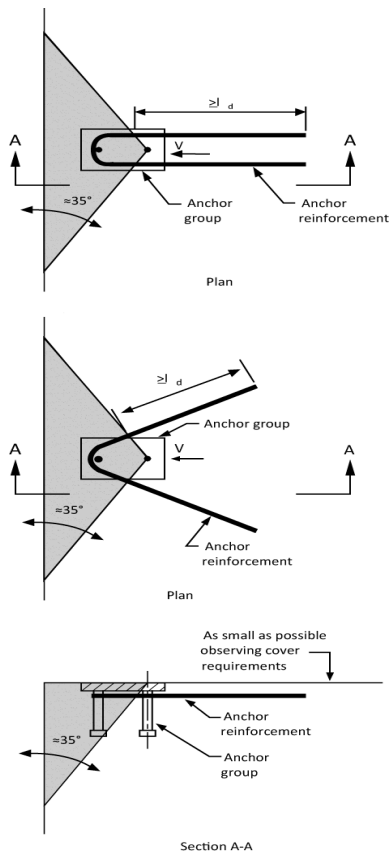


Figure 6.K.11(a) Hairpin anchor reinforcement for shear.

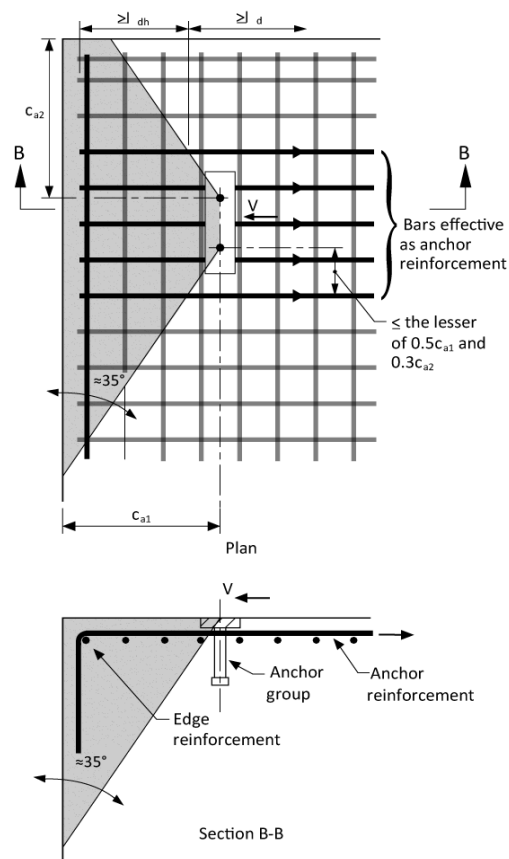


Figure 6.K.11(b) Edge reinforcement and anchor reinforcement for shear.

K.6.3 Concrete Pryout Strength of Anchor in Shear

Clarification for Section K.6.3: Concrete pryout strength of anchor in shear

Reference K.9 indicates that the pryout shear resistance can be approximated as one to two times the anchor tensile resistance with the lower value appropriate for h_{ef} less than 65 mm.

K.6.3.1 The nominal pryout strength, V_{cp} or V_{cpg} shall not exceed:

(a) For a single anchor

$$V_{cp} = k_{cp} N_{cb} \quad (6.K.30)$$

(b) For a group of anchors

$$V_{cpg} = k_{cp} N_{cbg} \quad (6.K.31)$$

Where,

$k_{cp} = 1.0$ for $h_{ef} < 65$ mm < 65 mm; and $k_{cp} = 2.0$ for $h_{ef} \geq 65$ mm.

N_{cb} and N_{cbg} shall be determined from Eq. 6.K.4 and 6.K.5, respectively.

K.7 Interaction of Tensile and Shear Forces

Unless determined in accordance with Sec K.4.3, anchors or groups of anchors that are subjected to both shear and axial loads shall be designed to satisfy the requirements of Sections K.7.1 to K.7.3. The value of ϕN_n shall be as required in Sec K.4.1.2. The value of ϕV_n shall be as defined in Sec K.4.1.2.

Clarification for Section K.7: Interaction of tensile and shear forces

The shear-tension interaction expression has traditionally been expressed as

$$\left(\frac{N_{ua}}{N_n} \right)^\zeta + \left(\frac{V_{ua}}{V_n} \right)^\zeta \leq 1.0$$

Where, ζ varies from 1 to 2. The current trilinear recommendation is a simplification of the expression where, $\zeta = 5/3$ (Figure 6.K.12). The limits were chosen to eliminate the requirement for computation of interaction effects where very small values of the

second force are present. Any other interaction expression that is verified by test data, however, can be used to satisfy Sec K.4.3.

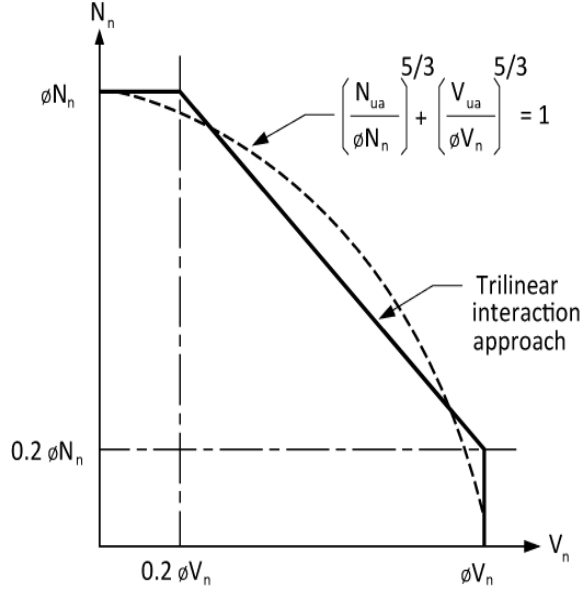


Figure 6.K.12 Shear and tensile load interaction equation.

K.7.1 If $V_{ua} \leq 0.2\phi V_n$, then full strength in tension shall be permitted: $\phi N_n \geq N_{ua}$.

K.7.2 If $N_{ua} \leq 0.2\phi N_n$, then full strength in tension shall be permitted: $\phi V_n \geq V_{ua}$.

K.7.3 If $V_{ua} > 0.2\phi V_n$ and $N_{ua} > 0.2\phi N_n$, then

$$\frac{N_{ua}}{\phi N_n} + \frac{V_{ua}}{\phi V_n} \leq 1.2 \quad (6.K.32)$$

K.8 Edge Distance, Spacing & Thickness Required Against Splitting Failure

Minimum spacing and edge distances for anchors and minimum thicknesses of members shall conform to Sections K.8.1 to K.8.6, unless supplementary reinforcement is provided to control splitting. Lesser values from product-specific tests performed in accordance with ACI 355.2 shall be permitted.

Clarification for Section K.8: Required edge distances, spacing, and thicknesses to preclude splitting failure

The minimum spacing, edge distances, and thicknesses are very dependent on the anchor characteristics. Installation forces and torques in post-installed anchors can cause splitting of the surrounding concrete. Such splitting also can be produced in subsequent torquing during connection of attachments to anchors including cast-in anchors. The primary source of values for minimum spacing, edge distances, and thicknesses of post-installed anchors should be the product-specific tests of ACI 355.2. In some cases, however, specific products are not known in the design stage. Approximate values are provided for use in design.

K.8.1 Unless determined in accordance with Sec K.8.4, minimum center-to-center spacing of anchors shall be $4d_a$ for untorqued cast-in anchors, and $6d_a$ for torque cast-in anchors and post-installed anchors.

K.8.2 Unless determined in accordance with Sec K.8.4, minimum edge distances for cast-in headed anchors that will not be torqued shall be based on specified cover requirements for reinforcement in Sec 8.1.7. For cast-in headed anchors that will be torqued, the minimum edge distances shall be $6d_a$.

Clarification for Section K.8.2: Because the edge cover over a deep embedment close to the edge can have a significant effect on the side face blowout strength of Sec K.5.4, in addition to the normal concrete cover requirements, it may be advantageous to use larger cover to increase the side-face blowout strength.

K.8.3 Unless determined in accordance with Sec K.8.4, minimum edge distances for post-installed anchors shall be based on the greater of specified cover requirements for reinforcement in Sec 8.1, or minimum edge distance requirements for the products as determined by tests in accordance with ACI 355.2, and shall not be less than 2.0 times the maximum aggregate size. In the absence of product-specific ACI 355.2 test information, the minimum edge distance shall be taken as not less than:

Undercut anchors	$6d_a$
Torque-controlled anchors	$8d_a$
Displacement-controlled anchors	$10d_a$

Clarification for Section K.8.3: Drilling holes for post-installed anchors can cause microcracking. The requirement for a minimum edge distance twice the maximum aggregate size is to minimize the effects of such microcracking.

K.8.4 For anchors where installation does not produce a splitting force and that will remain untorqued, if the edge distance or spacing is less than those specified in Sections K.8.1 to K.8.3, calculations shall be performed by substituting for d_a a smaller value d'_a that meets the requirements of Sections K.8.1 to K.8.3. Calculated forces applied to the anchor shall be limited to the values corresponding to an anchor having a diameter of d'_a .

Clarification for Section K.8.4: In some cases, it may be desirable to use a larger diameter anchor than the requirements on K.8.1 to K.8.3 permit. In these cases, it is permissible to use a larger-diameter anchor provided the design strength of the anchor is based on a smaller assumed anchor diameter, d'_a .

K.8.5 The value of h_{ef} for an expansion or undercut post-installed anchor shall not exceed the greater of $2/3$ of the member thickness and the member thickness minus 100 mm.

Clarification for Section K.8.5: This minimum thickness requirement is not applicable to through-bolts because they are outside the scope of Appendix K. In addition, splitting failures are caused by the load transfer between the bolt and the concrete. Because through-bolts transfer their load differently than cast-in or expansion and undercut anchors, they would not be subject to the same member thickness requirements. Post-installed anchors should not be embedded deeper than $2/3$ of the member thickness.

K.8.6 Unless determined from tension tests in accordance with ACI 355.2, the critical edge distance, C_{ac} , shall not be taken less than:

Undercut anchors	$2.5h_{ef}$
Torque-controlled anchors	$4h_{ef}$
Displacement-controlled anchors	$4h_{ef}$

Clarification for Section K.8.6: The critical edge distance C_{ac} is determined by the corner test in ACI 355.2. Research has indicated that the corner-test requirements are not met with $C_{a,min} = 1.5h_{ef}$ for many expansion anchors and some undercut anchors because installation of these types of anchors introduces splitting tensile stresses in the concrete that are increased during load application, potentially resulting in a premature splitting failure. To permit the design of these types of anchors when product-specific information is not available, conservative default values for C_{ac} are provided.

K.8.7 Project drawings and project specifications shall specify use of anchors with a minimum edge distance as assumed in design.

K.9 Installation of Anchors

Clarification for Section K.9: Installation of anchors

Many anchor performance characteristics depend on proper installation of the anchor. Anchor strength and deformation capacity can be assessed by acceptance testing under ACI 355.2. These tests are carried out assuming that the manufacturer's installation directions will be followed. Certain types of anchors can be sensitive to variations in hole diameter, cleaning conditions, orientation of the axis, magnitude of the installation torque, crack width, and other variables. Some of this sensitivity is indirectly reflected in the assigned ϕ values for the different anchor categories, which depend in part on the results of the installation safety tests. Gross deviations from the ACI 355.2 acceptance testing results could occur if anchor components are incorrectly exchanged, or if anchor installation criteria and procedures vary from those recommended. Project specifications should require that anchors be installed according to the manufacturer's recommendations.

K.9.1 Anchors shall be installed in accordance with the project drawings and project specifications.

K. 10 References of Appendix K

- K.1. ANSI/ASME B1.1, "Unified Inch Screw Threads (UN and UNR Thread Form)," ASME, Fairfield, NJ, 1989.
- K.2. ANSI/ASME B18.2.1, "Square and Hex Bolts and Screws, Inch Series," ASME, Fairfield, NJ, 1996.
- K.3. ANSI/ASME B18.2.6, "Fasteners for Use in Structural Applications," ASME, Fairfield, NJ, 1996.
- K.4. Cook, R. A., and Klingner, R. E., "Behavior of Ductile Multiple-Anchor Steel-to-Concrete Connections with Surface-Mounted Baseplates," *Anchors in Concrete: Design and Behavior*, SP-130, American Concrete Institute, Farmington Hills, MI, 1992, pp. 61-122.
- K.5. Cook, R. A., and Klingner, R. E., "Ductile Multiple-Anchor Steel-to-Concrete Connections," *Journal of Structural Engineering*, ASCE, V. 118, No. 6, June 1992, pp. 1645-1665.
- K.6. Lotze, D.; Klingner, R. E.; and Graves III, H. L., "Static Behavior of Anchors under Combinations of Tension and Shear Loading," *ACI Structural Journal*, V. 98, No. 4, July-Aug. 2001, pp. 525-536.

-
- K.7. Primavera, E. J.; Pinelli, J.-P.; and Kalajian, E. H., "Tensile Behavior of Cast-in-Place and Undercut Anchors in High-Strength Concrete," *ACI Structural Journal*, V. 94, No. 5, Sept.-Oct. 1997, pp. 583-594.
- K.8. *Design of Fastenings in Concrete*, Comite Euro-International du Beton (CEB), Thomas Telford Services Ltd., London, Jan. 1997.
- K.9. Fuchs, W.; Eligehausen, R.; and Breen, J., "Concrete Capacity Design (CCD) Approach for Fastening to Concrete," *ACI Structural Journal*, V. 92, No. 1, Jan.-Feb. 1995, pp. 73-93. Also discussion, *ACI Structural Journal*, V. 92, No. 6, Nov.-Dec. 1995, pp. 787-802.
- K.10. Eligehausen, R., and Balogh, T., "Behavior of Fasteners Loaded in Tension in Cracked Reinforced Concrete," *ACI Structural Journal*, V. 92, No. 3, May-June 1995, pp. 365-379.
- K.11. "Fastenings to Concrete and Masonry Structures, State of the Art Report," Comite Euro-International du Beton (CEB), Bulletin No. 216, Thomas Telford Services Ltd., London, 1994.
- K.12. Klingner, R.; Mendonca, J.; and Malik, J., "Effect of Reinforcing Details on the Shear Resistance of Anchor Bolts under Reversed Cyclic Loading," *ACI JOURNAL*, Proceedings V. 79, No. 1, Jan.-Feb. 1982, pp. 3-12.
- K.13. ACI Committee 349, "Code Requirements for Nuclear Safety Related Concrete Structures (ACI 349-01)," American Concrete Institute, Farmington Hills, MI, 2001, 134 pp.
- K.14. Eligehausen, R.; Mallée, R.; and Silva, J., *Anchorage in Concrete Construction*, Ernst & Sohn (J. T. Wiley), Berlin, May 2006, 380 pp.
- K.15. Eligehausen, R.; Fuchs, W.; and Mayer, B., "Load Bearing Behavior of Anchor Fastenings in Tension," *Betonwerk + Fertigteiltechnik*, 12/1987, pp. 826-832, and 1/1988, pp. 29-35.
- K.16. Eligehausen, R., and Fuchs, W., "Load Bearing Behavior of Anchor Fastenings under Shear, Combined Tension and Shear or Flexural Loadings," *Betonwerk + Fertigteiltechnik*, 2/1988, pp. 48-56.
- K.17. Farrow, C. B., and Klingner, R. E., "Tensile Capacity of Anchors with Partial or Overlapping Failure Surfaces: Evaluation of Existing Formulas on an LRFD Basis," *ACI Structural Journal*, V. 92, No. 6, Nov.-Dec. 1995, pp. 698-710.

-
- K.18. PCI Design Handbook, 5th Edition, Precast/Prestressed Concrete Institute, Chicago, IL, 1999.
- K.19. “AISC Load and Resistance Factor Design Specifications for Structural Steel Buildings,” Dec. 1999, 327 pp.
- K.20. Zhang, Y.; Klingner, R. E.; and Graves III, H. L., “Seismic Response of Multiple-Anchor Connections to Concrete,” ACI Structural Journal, V. 98, No. 6, Nov.-Dec. 2001, pp. 811-822.
- K.21. Lutz, L., “Discussion to Concrete Capacity Design (CCD) Approach for Fastening to Concrete,” ACI Structural Journal, Nov.-Dec. 1995, pp. 791-792. Also authors’ closure, pp. 798-799.
- K.22. Asmus, J., “Verhalten von Befestigungen bei der Versagensart Spalten des Betons (Behavior of Fastenings with the Failure Mode Splitting of Concrete),” dissertation, Universität Stuttgart, Germany, 1999.
- K.23. Kuhn, D., and Shaikh, F., “Slip-Pullout Strength of Hooked Anchors,” Research Report, University of Wisconsin-Milwaukee, submitted to the National Codes and Standards Council, 1996.
- K.24. Furche, J., and Eligehausen, R., “Lateral Blow-out Failure of Headed Studs Near a Free Edge,” Anchors in Concrete—Design and Behavior, SP-130, American Concrete Institute, Farmington Hills, MI, 1991, pp. 235-252.
- K.25. Shaikh, A. F., and Yi, W., “In-Place Strength of Welded Studs,” PCI Journal, V. 30, No. 2, Mar.-Apr. 1985.

PART VI
Appendix L
Information on Steel Reinforcement

Information on sizes, areas, and weights of various steel reinforcement is presented below to facilitate the use of Bangladesh National Building Code.

Table 6.L.1: Sizes, Areas, and Weights of Reinforcing Bars (ASTM Standard)

Bar Size, No.*	Nominal Diameter, mm	Nominal Area, mm ²	Nominal Mass, kg/m
10	9.5	71	0.560
13	12.7	129	0.994
16	15.9	199	1.552
19	19.1	284	2.235
22	22.2	387	3.042
25	25.4	510	3.973
29	28.7	645	5.060
32	32.3	819	6.404
36	35.8	1006	7.907
43	43.0	1452	11.38
57	57.3	2581	20.24

**Bar numbers approximate the number of millimeters of the nominal diameter of the bar. Within the text in Chapters, the referred ϕ (diameter in mm) of bars correspond to the figures in the first column (Bar size, no.)*

Table 6.L.2: Sizes, Areas, and Weights of Prestressing Tendons (ASTM Standard)

Type*	Nominal Diameter, mm	Nominal Area, mm ²	Nominal Mass, kg/m
Seven-wire strand (Grade 1725)	6.4	23.2	0.182
	7.9	37.4	0.294
	9.5	51.6	0.405
	11.1	69.7	0.548
	12.7	92.9	0.730
Seven-wire strand (Grade 1860)	15.2	139.4	1.094
	9.53	54.8	0.432
	11.1	74.2	0.582
	12.70	98.7	0.775
Prestressing wire	15.24	140.0	1.102
	4.88	18.7	0.146
	4.98	19.5	0.149
	6.35	31.7	0.253
Prestressing bars (plain)	7.01	38.6	0.298
	19	284	2.23
	22	387	3.04
	25	503	3.97
	29	639	5.03
	32	794	6.21
Prestressing bars (deformed)	35	955	7.52
	15	181	1.46
	20	271	2.22
	26	548	4.48
	32	806	6.54
	36	1019	8.28

*Depends on availability of some tendon sizes.

Table 6.L.3: Sizes, Areas, and Weights of Wire Reinforcement* (WRI Standard)

MW & MD size		Nominal Diameter, mm	Nominal Mass, kg/m	Area, mm ² /m of Width for Various Spacings							
Plain	Deformed			Center-to-center spacing, mm							
				50	75	100	150	200	250	300	
MW290	MD290	19.22	2.27	5800	3900	2900	1900	1450	1160	970	
MW200	MD200	15.95	1.5700	4000	2700	2000	1300	1000	800	670	
MW130	MD130	12.90	1.0204	2600	1700	1300	870	650	520	430	
MW120	MD120	12.40	0.9419	2400	1600	1200	800	600	480	400	
MW100	MD100	11.30	0.7849	2000	1300	1000	670	500	400	330	
MW90	MD90	10.70	0.7064	1800	1200	900	600	450	360	300	
MW80	MD80	10.10	0.6279	1600	1100	800	530	400	320	270	
MW70	MD70	9.40	0.5494	1400	930	700	470	350	280	230	
MW65	MD65	9.10	0.5102	1300	870	650	430	325	260	220	
MW60	MD60	8.70	0.4709	1200	800	600	400	300	240	200	
MW55	MD55	8.40	0.4317	1100	730	550	370	275	220	180	
MW50	MD50	8.00	0.3925	1000	670	500	330	250	200	170	
MW45	MD45	7.60	0.3532	900	600	450	300	225	180	150	
MW40	MD40	7.10	0.3140	800	530	400	270	200	160	130	
MW35	MD35	6.70	0.2747	700	470	350	230	175	140	120	
MW30	MD30	6.20	0.2355	600	400	300	200	150	120	100	
MW25	MD25	5.60	0.1962	500	330	250	170	125	100	83	
MW20		5.00	0.1570	400	270	200	130	100	80	67	
MW15		4.40	0.1177	300	200	150	100	75	60	50	
MW10		3.60	0.0785	200	130	100	70	50	40	33	
MW5		2.50	0.0392	100	67	50	33	25	20	17	

Table 6.L.4: Dimensions, Mass per Unit Length and Permissible Deviations (BDS ISO_6935-1)

Nominal Bar Diameter, <i>d</i> mm	Nominal Cross-Sectional Area ^a <i>A_n</i> mm ²	Mass per Unit Length	
		Requirement ^b kg/m	Permissible deviation ^c %
6	28,3	0,222	± 8
8	50,3	0,395	± 8
10	78,5	0,617	± 5
12	113	0,888	± 5
14	154	1,21	± 5
16	201	1,58	± 5
20	314	2,47	± 5
22	380	2,98	± 5

^a $A_n=0,785\ 4\times d^2$

^b Mass per unit length = $7,85\times 10^{-3}\ A_n$

^c Permissible deviation refers to a single bar.

Table 6.L.5: Dimensions, Mass per Unit Length and Permissible Deviations (BDS ISO_6935-2)

Nominal Bar Diameter ^a , <i>d</i> mm	Nominal Cross-Sectional Area ^b <i>A_n</i> mm ²	Mass per unit length	
		Requirement ^c Kg/m	Permissible deviation ^d %
6	28,3	0,222	± 8
8	50,3	0,395	± 8
10	78,5	0,617	± 6
12	113	0,888	± 6
14	154	1,21	± 5
16	201	1,58	± 5
20	314	2,47	± 5
25	491	3,85	± 4
28	616	4,84	± 4
32	804	6,31	± 4
40	1257	9,86	± 4
50	1964	15,42	± 4

^a Diameters larger than 50mm should be agreed between the manufacturer and purchaser. The permissible deviation on such bars shall be ± 4 %

^b $A_n=0,785\ 4\times d^2$

^c Mass per unit length = $7,85\times 10^{-3}\ A_n$

^d Permissible deviation refers to a single bar.

PART VI
Appendix M
Special Types of Stairs

M.1 Free Standing Stair (Landing Unsupported)

M.1.1 Span and Geometry

The span and geometry for flights and landings of free standing stair as well as the different forces and moments required for the design of the stair are shown in Figure 6.M.1. The stair shall be supported at floor levels on rigid supports.

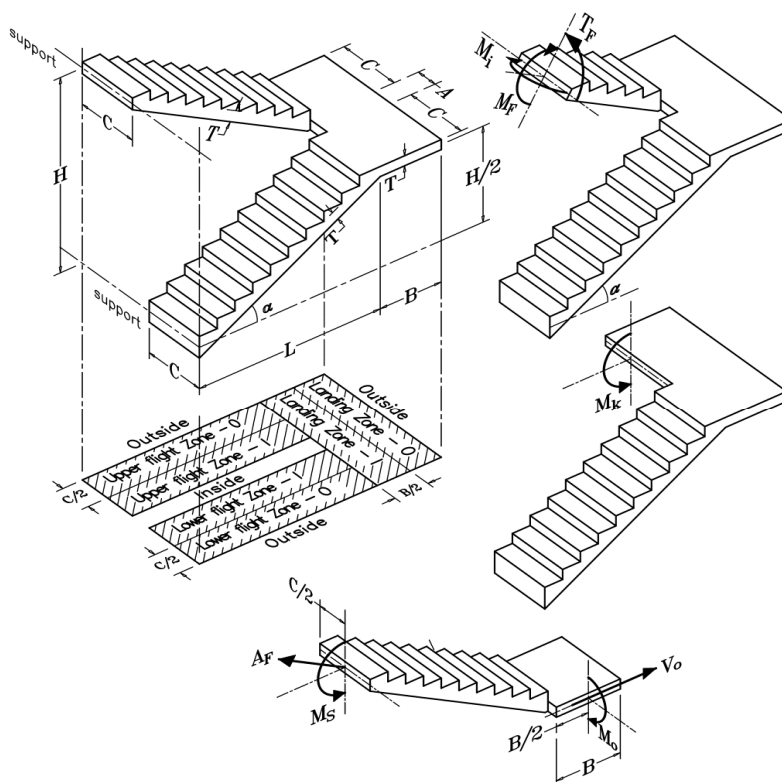


Figure 6.M.1 Free standing stair geometry and forces and moments required for design.

M.1.2 Loading and Load combinations

Staircases shall, generally, be designed to support the design uniformly distributed load according to the load combinations specified in Chapter 2, loads. For common free standing stairs, it generally sufficient to design for gravity loading only, using the relevant load combinations.

M.1.3 Design

M.1.3.1 Empirical expressions for forces and moments (Fig.6.M.1) at critical locations of stair in terms of stair geometric and material parameters under service load are given in Table 6.M.1.

Table 6.M.1: Expressions for Free Standing Stair Forces and Moments under Service Load

Sl.	Description	Expression	Unit
1.	Deflection at landing corner, δ	$0.002 \times [1 + 3.6(A - 0.125)^{0.94}] \times [1 + 2.275(B - 0.915)^{1.1}] \times [1 + 1.017(C - 0.914)^{0.93}] \times [1 - 7.87 \times 10^{-3}(L - 2.03)] \times [1 - 0.2(H - 2.44)] \times [1 - 1.617(T - 0.1)^{0.334}] \times [1 - 1.074 \times 10^{-6}(f'_c - 14)^{0.93}]$	m
2.	Support moment, M_S	$4.712 \times [1.555 + 0.787(A - 0.05)] \times [1.06 - 0.22(B - 0.86)] \times [1.2 + 2.76(C - 0.864)] \times [1 + 0.748(L - 2.03)] \times [1 + 5.9 \times 10^{-3}(H - 2.44)] \times [0.39 + 1.73(T - 0.09)]$	kN-m
3.	Flight mid-span moment, M_F	$1.526 \times [1.1 - 1.143(A - 0.15)^{1.52}] \times [1 - 0.872(B - 0.915)^{1.365}] \times [1 + 12.22(L - 2.03)^{2.66}] \times [1 + 0.184(H - 2.44)^{2.77}] \times [1 - 5.34(T - 0.1)^{1.17}]$	kN-m
4.	Moment at flight-landing junction, M_K	$3.447 \times [1.23 + 0.512(A - 0.125)] \times [1.01 + 3.23(B - 0.915)] \times [0.85 + 0.709(C - 0.915)] \times [0.95 + 5.5(T - 0.1)^{1.03}]$	kN-m
5.	Moment at mid-landing section, M_o	$6.14 \times [1 + 0.303(A - 0.15)] \times [1 + 1.18(B - 0.915)] \times [1 + 1.06(C - 0.915)] \times [1 + 0.409(L - 2.03)] \times [1 + 0.02637(H - 2.04)] \times [1 + 1.85(T - 0.1)]$	kN-m
6.	Axial force in flights, A_F	$34.69 \times [1 + 0.236(A - 0.125)] \times [1 + 0.787(B - 0.915)] \times [1 + 0.827(C - 0.915)] \times [1 + 0.354(L - 2.03)] \times [1 - 0.157(H - 2.44)] \times [1 + 2.76(T - 0.1)]$	kN
7.	Torsion in flights, T_F	$2.312 \times [1 + 1.77(A - 0.125)] \times [1 + 0.63(B - 0.915)] \times [1 + 2.68(C - 0.915)] \times [1 - 1.423 \times 10^{-3}(L - 2.03)^{0.75}] \times [1 + 3.58(T - 0.1)]$	kN-m
8.	In-plane moment in flights, M_I	$14.35 \times [1.1 + 0.866(A - 0.15)] \times [1 + 0.984(B - 0.915)] \times [1 + 1.57(C - 0.915)] \times [1 + 0.59(L - 2.03)] \times [1 - 0.197(H - 2.44)] \times [1 + 2.6(T - 0.1)]$	kN-m
9.	Lateral shear at mid-landing section, V_o	$30.17 \times [1 - 0.276(A - 0.15)] \times [1 + 1.38(B - 0.915)] \times [1 + 0.709(C - 0.915)] \times [1 + 0.669(L - 2.03)] \times [1 - 0.24(H - 2.44)] \times [1 + 6.092(T - 0.1)^{1.3}]$	kN

In the above expressions, the unit of length is meter and the unit of force is kilo-Newton. The unit for f'_c is in MPa. The ranges of parameters for which the above expressions are applicable are as follows:

$0.15 \leq A \leq 1.0$, $0.92 \leq B \leq 1.9$, $0.92 \leq C \leq 1.9$, $2.0 \leq L \leq 3.6$, $2.44 \leq H \leq 4.32$, $0.1 \leq T \leq 0.28$, $14 \leq f'_c \leq 40$.

M.1.3.2 The empirical expressions of forces and moments given above provide working/service values corresponding to 5.0 kN/m² service live load and appropriate service dead load of slab and steps based on unit weight of 23.56 kN/m³. Forces and moments for other values of live load, L_L , may be calculated by simple proportioning. This can be reasonably done by multiplying the quantities of Table 6.M.1 by a factor $(23.56 T + L_L + 2.36)/(23.56 T + 7.36)$ where L_L is in kN/m² and T is in meter. Once the working/service values are obtained for desired load as described, the ultimate design values (factored) for USD method of reinforcement design may be obtained by multiplying the working values by a conversion factor equal to $(1.2D_L + 1.6L_L)/(D_L + L_L)$ where D_L is the dead load in kN/m². For 5.0 kN/m² live load and concrete unit weight of 23.56 kN/m³, this conversion factor can safely be approximated as $(42.41 T + 8.0)/(35.34 T + 5.0)$. Once the values of design moments and forces are obtained, design procedure of Chapter 6 (Part 6) may be employed for the reinforcement design of flights and landing.

M.1.3.3 Moments M_S , M_K and M_O are such that they produce tension in the top fiber requiring longitudinal slab reinforcement to be placed near the top face of slab. Moment M_F produce tension in the bottom fiber of flight slab requiring longitudinal reinforcement to be placed near the bottom face of slab. Axial force A_F produce tension in upper flight and compression in lower flight. This requires tension reinforcement to be provided only in the upper flight. In-plane moment M_I acts in such a manner that it produces tension along the inner edge of upper flight and outer edge of lower flight.

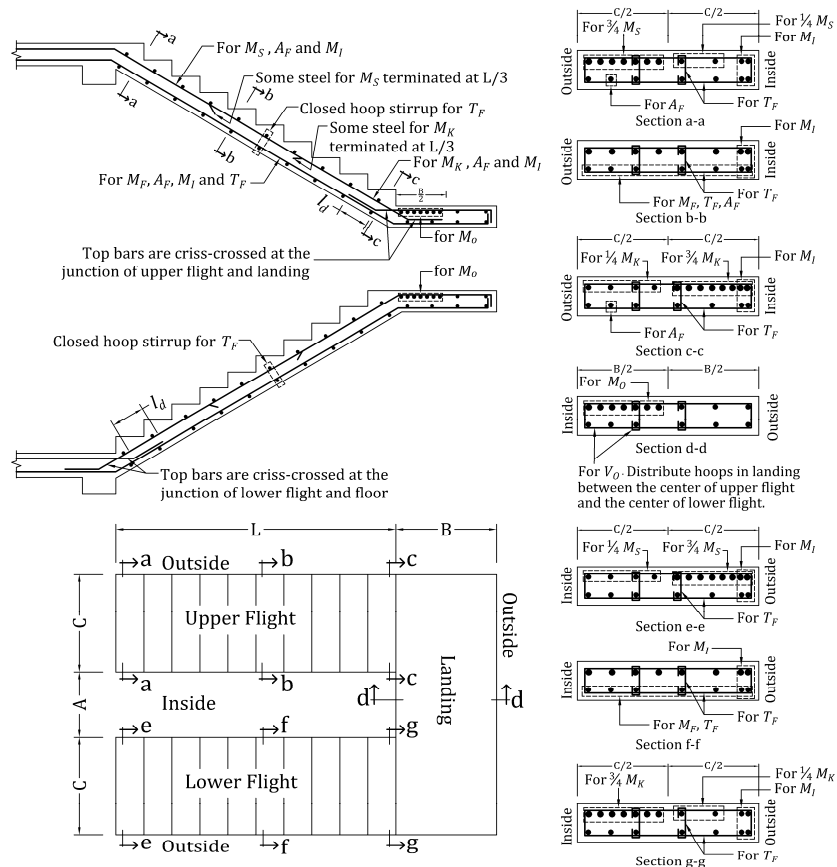


Figure 6.M.2 Recommended reinforcement layout details for free standing stair

M.1.3.4 Apart from maintaining the standard code provisions in detailing the reinforcement as stipulated elsewhere in this Code, additional detailing shall be done to take care of the features which are special to the free standing stairway. To account for the non-uniform distribution of the bending moment M_S at support across the width of the slab, 75 percent of the total negative steel shall be distributed across the outer half of the width (Zone – O in Fig. 6.M.1) of support section for both the flights and the rest of the negative steel shall be distributed within the inner half of the width of support section (Zone – I). For moment M_K , 75 percent of the total negative steel shall be distributed across the inner half of the width (Zone – I in Fig. 6.M.1) of flight-landing junction for both the flights and the rest of the negative steel shall be distributed within the outer half of the width of section (Zone – O at flight-landing junction). For moment M_o , the total negative steel shall be distributed across the inner half of the width (Landing Zone – I in Fig. 6.M.1) and the rest of the section shall be provided with nominal reinforcement as per provisions of Chapter 6. At mid-span of flights, the positive steel required for M_F shall be distributed uniformly across the section. Longitudinal steel required to resist flight in-plane moment M_I shall be placed near the inner edge in Zone-I of upper flight and near the outer edge in Zone-O of lower flight. Longitudinal steel required to resist tensile axial force A_F in upper flight may be distributed across the section of upper flight. Closed rectangular hoop reinforcements accompanied by cross ties shall be designed to resist the action of torsion in flights and lateral shear at mid-landing section. The suggested bar detailing for the free standing stairway is shown in Figure 6.M.2.

M.2 Sawtooth Stair

M.2.1 Loading

Sawtooth (slab less) stair shall be designed to support the design ultimate load according to the load combinations specified in Chapter 2, Loads.

M.2.2 Distribution of Loading

Where flights or landing are embedded at least 110 mm into the walls and are designed to span in the direction of the flight, a 150 mm strip may be deducted from the loaded area and the effective breadth of the section may be increased by 75 mm for the purpose of design (Figure 6.M.3).

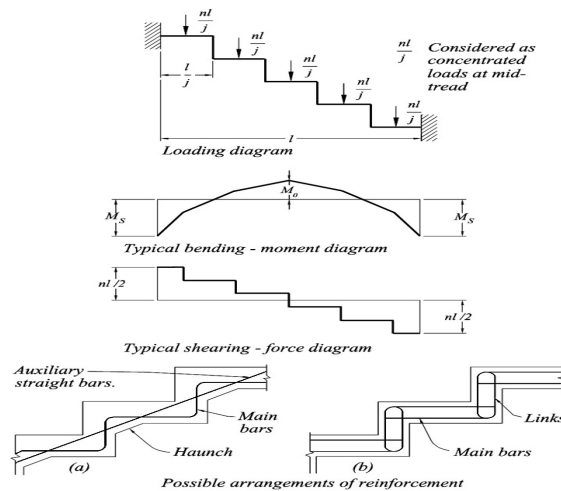


Figure 6.M.3 Elements of saw-tooth stair and typical reinforcement arrangements

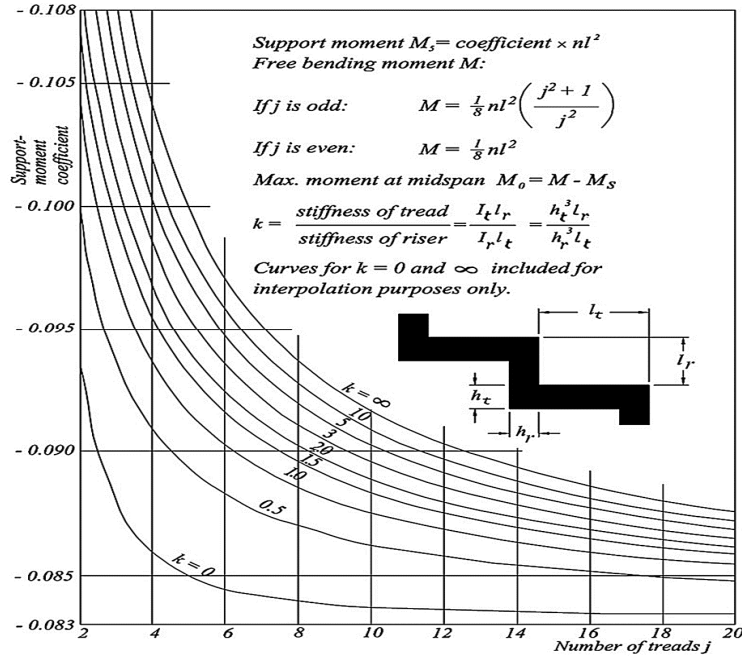


Figure 6.M.4 Support moment coefficients for saw-tooth stair

M.2.3 Effective Span

Sawtooth stairs shall be supported with stringer beams or walls at landing levels (Figure 6.M.3). The effective span for the stair shall be the going of the stair measured horizontally (Figure 6.M.3) from the face of the stringer beam or wall.

M.2.3.1 Design

The support moments for sawtooth stairs are given by:

$$M_s = \frac{nl^3 (k_{11} + k_0 k_{13})}{j^3 (k_{13} + k_0 k_{14})} \tag{6.M.1}$$

Where, k_0 = stiffness of tread/stiffness of riser and j is the number of treads and n is the width of flight (Figure 6.M.3).

If j is odd: $k_{11} = \frac{1}{16} j^2 + \frac{1}{48} j(j-1)(j-2),$

$$k_{12} = \frac{1}{16} (j-1)^2 + \frac{1}{48} j(j-1)(j-2)(j-3),$$

$$k_{13} = \frac{1}{2} j, \quad k_{14} = \frac{1}{2} (j-1).$$

If j is even: $k_{11} = \frac{1}{48} j(j-1)(j-2),$ $k_{12} = \frac{1}{48} (j-1)(j-2)(j-3),$

$$k_{13} = \frac{1}{2} (j-1),$$

$$k_{14} = \frac{1}{2} (j-2)$$

The chart on Figure 6.M.4 gives the support-moment coefficients for various ratios of stiffness of tread/stiffness of riser and numbers of treads. Having found the support moment, the maximum mid-span bending moment can be alternatively determined by using the appropriate expression on the Figure 6.M.4 and subtracting the support moment.

M.2.4 Detailing

Typical bending-moment and shearing-force diagrams for a stair are shown on Figure 6.M.3 together with suggested arrangements of reinforcement. The re-entrant corners of the stair-profile shall be designed for stress concentrations. This has to be facilitated by providing twice of the reinforcements calculated from Eq. 6.M.1 and Figure 6.M.4. Fillets or haunches can also be incorporated in lieu at these junctions. The method of reinforcing the stair shown in diagram (a) of Figure 6.M.3 is very suitable but is generally only practicable if haunches are provided. Otherwise the arrangement shown in diagram (b) should be adopted.

M.3 Helicoidal Stair

M.3.1 Loading

Helicoidal stair shall be designed to support the design ultimate load according to the load combinations specified in Chapter 2, Loads.

M.3.2 Geometry

The pertinent geometry of the Helicoidal stair is given at Figure 6.M.5 where:

- b : Width of stair slab
- h : Thickness of the stair slab
- n : Total load per unit length projected along centre-line of load
- R_1 : Radius of centre-line of loading = $(2/3)(R_0^3 - R_i^3)/(R_0^2 - R_i^2)$
- R_2 : Radius of centre-line of steps = $(1/2)(R_i + R_o)$, where R_i and R_o are the internal and external radii of the stair, respectively
- θ : Angle subtended in plan between point considered and midpoint of stair
- β : Total angle subtended by helix in plan
- ϕ : Slope of tangent to helix center-line measured from horizontal
- M_o : Bending moment at midpoint of stair.
- H : Lateral shear at the midpoint of stair.
- I_1, I_2 : Second moment of area of stair section about horizontal axis and axis normal to slope, respectively

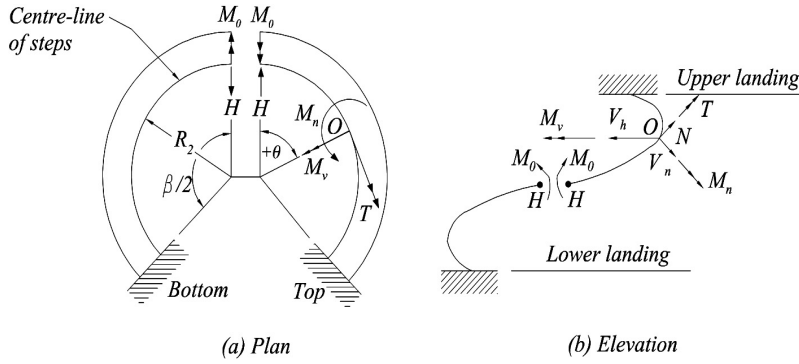


Figure 6.M.5 Elements of helicoidal stair

M.3.3 Effective Span

Helicoidal stairs shall be supported with stringer beams at landing levels (Figure 6.M.5). The effective span for the stair shall be βR , where β is the total angle subtended by helix in plan measured horizontally (Figure 6.M.5) from the face of the stringer beams.

M.3.4 Depth of Section

The depth of the section shall be taken as the minimum thickness perpendicular to the soffit of the stair unless otherwise the large geometric dimensions warrant calculating the deflections through a suitable numerical analysis.

M.3.5 Design

The moments, thrust, torsion and shear forces shall be obtained from the following equations:

Lateral moment (in-plane moment):

$$M_n = M_o \sin \theta \sin \phi - HR_2 \theta \tan \phi \cos \theta \sin \phi - HR_2 \sin \theta \cos \phi + nR_1 \sin \phi (R_1 \sin \theta - R_2 \theta) \quad (6.M.2)$$

Torsional moment:

$$T = (M_o \sin \theta - HR_2 \theta \cos \theta \tan \phi + nR_1^2 \sin \theta - nR_1 R_2 \theta) \cos \phi + HR_2 \sin \theta \sin \phi \quad (6.M.3)$$

Vertical moment (bending moment):

$$M_y = M_o \cos \theta + HR_2 \theta \tan \phi \sin \theta - nR_1^2 (1 - \cos \theta) \quad (6.M.4)$$

Thrust (axial force):

$$N = -H \sin \theta \cos \phi - nR_1 \theta \sin \phi \quad (6.M.5)$$

Lateral shearing force across stair:

$$V_n = nR_1 \theta \cos \phi - H \sin \theta \sin \phi \quad (6.M.6)$$

Radial horizontal shearing force:

$$V_h = H \cos \theta \quad (6.M.7)$$

Where,

$$M_o = \text{redundant moment acting tangentially at mid-span} = k_1 n R_2^2 \quad (6.M.8)$$

$$H = \text{horizontal redundant force at mid-span} = k_2 n R_2 \quad (6.M.9)$$

$$M_{vs} = \text{vertical moment at supports} = k_3 n R_2^2 \quad (6.M.10)$$

The values of coefficients k_1 , k_2 and k_3 can be obtained from the charts provided in Figures 6.M.6 to 6.M.9 for different combinations of R_1/R_2 and b/h ratios. To determine values of coefficients k_1 , k_2 and k_3 for other intermediate values of R_1/R_2 and b/h ratios, interpolations may be performed.

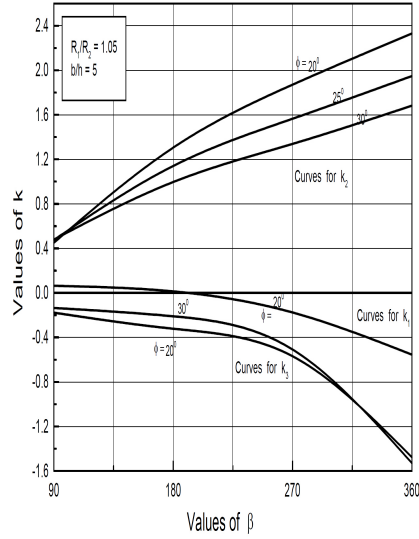


Figure 6.M.6 Design charts for helicoidal stair slabs for $R_1/R_2 = 1.05$ and $b/h = 5$.

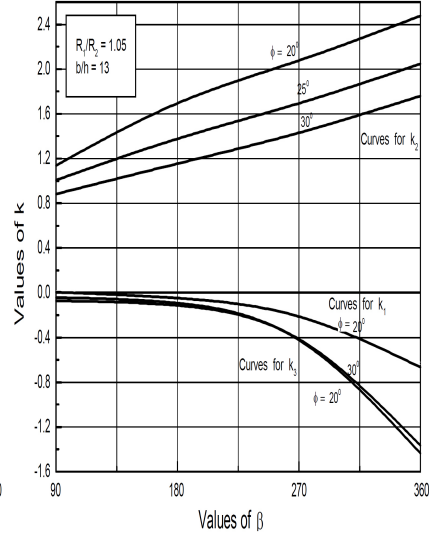


Figure 6.M.7 Design charts for helicoidal stair slabs for $R_1/R_2 = 1.05$ and $b/h = 13$.

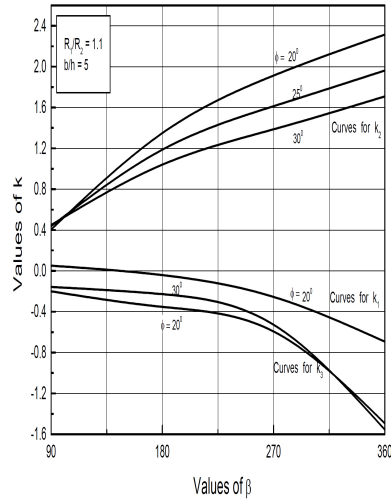


Figure 6.M.8 Design charts for helicoidal stair slabs for $R_1/R_2 = 1.1$; $b/h = 5$.

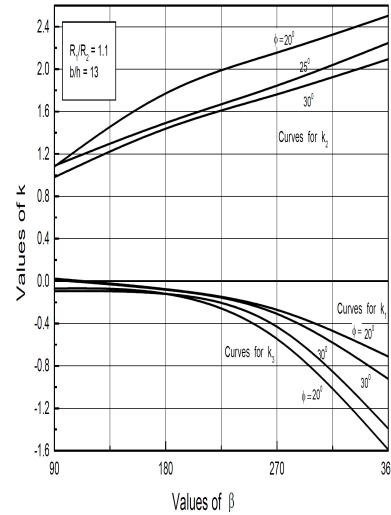


Figure 6.M.9 Design charts for helicoidal stair slabs for $R_1/R_2 = 1.1$; $b/h = 13$.

PART VI
Appendix N
Prequalification of Beam-Column and
Link-to-Column Connections

N.1 Scope

This Appendix contains minimum requirements for prequalification of beam-to-column moment connections in special moment frames (SMF), intermediate moment frames (IMF), and link-to-column connections in eccentrically braced frames (EBF). Prequalified connections are permitted to be used, within the applicable limits of prequalification, without the need for further qualifying cyclic tests. When the limits of prequalification or design requirements for prequalified connections conflict with the requirements of these Provisions, the limits of prequalification and design requirements for prequalified connections shall govern.

N.2 General Requirements

N.2.1 Basis for Prequalification

Connections shall be prequalified based on test data satisfying Section N.3, supported by analytical studies and design models. The combined body of evidence for prequalification must be sufficient to assure that the connection can supply the required interstory drift angle for SMF and IMF systems, or the required link rotation angle for EBF, on a consistent and reliable basis within the specified limits of prequalification. All applicable limit states for the connection that affect the stiffness, strength and deformation capacity of the connection and the seismic load resisting system (SLRS) must be identified. These include fracture related limit states, stability related limit states, and all other limit states pertinent for the connection under consideration. The effect of design variables listed in Section N.4 shall be addressed for connection prequalification.

N.2.2 Authority for Prequalification

Prequalification of a connection and the associated limits of prequalification shall be established by a connection prequalification review panel (CPRP) approved by the authority having jurisdiction.

N.3 Testing Requirements

Data used to support connection prequalification shall be based on tests conducted in accordance with Appendix Q. The CPRP shall determine the number of tests and the variables considered by the tests for connection prequalification. The CPRP shall also provide the same information when limits are to be changed for a previously prequalified connection. A sufficient number of tests shall be performed on a sufficient number of nonidentical specimens to demonstrate that the connection has the ability and reliability to undergo the required interstory drift angle for SMF and IMF and the required link rotation angle for EBF, where the link is adjacent to columns. The limits on member sizes for prequalification shall not exceed the limits specified in Appendix Q, Section Q.5.2.

N.4 Prequalification Variables

In order to be prequalified, the effect of the following variables on connection performance shall be considered. Limits on the permissible values for each variable shall be established by the CPRP for the prequalified connection.

- (1) Beam or link parameters:
 - (a) Cross-section shape: wide flange, box, or other.
 - (b) Cross-section fabrication method: rolled shape, welded shape, or other.
 - (c) Depth.
 - (d) Weight per foot.
 - (e) Flange thickness.
 - (f) Material specification.
 - (g) Span-to-depth ratio (for SMF or IMF), or link length (for EBF)
 - (h) Width thickness ratio of cross-section elements.
 - (i) Lateral bracing.
 - (j) Other parameters pertinent to the specific connection under consideration.
- (2) Column parameters:
 - (a) Cross-section shape: wide flange, box, or other.
 - (b) Cross-section fabrication method: rolled shape, welded shape, or other.
 - (c) Column orientation with respect to beam or link: beam or link is connected to column flange, beam or link is connected to column web, beams or links are connected to both the column flange and web, or other.
 - (d) Depth.
 - (e) Weight per foot.
 - (f) Flange thickness.
 - (g) Material specification.
 - (h) Width-thickness ratio of cross-section elements.
 - (i) Lateral bracing.
 - (j) Other parameters pertinent to the specific connection under consideration.
- (3) Beam (or link)—column relations:
 - (a) Panel zone strength
 - (b) Doubler plate attachment details
 - (c) Column-beam (or link) moment ratio

- (4) Continuity plates:
- (a) Identification of conditions under which continuity plates are required
 - (b) Thickness, width and depth
 - (c) Attachment details
- (5) Welds:
- (a) Location, extent (including returns), type (CJP, PJP, fillet, etc.) and any reinforcement or contouring required
 - (b) Filler metal classification strength and notch toughness
 - (c) Details and treatment of weld backing and weld tabs
 - (d) Weld access holes: size, geometry and finish
 - (e) Welding quality control and quality assurance beyond that described in Appendix O, including the nondestructive testing (NDT) method, inspection frequency, acceptance criteria and documentation requirements
- (6) Bolts:
- (a) Bolt diameter
 - (b) Bolt grade: ASTM A325, A490, or other
 - (c) Installation requirements: pretensioned, snug-tight, or other
 - (d) Hole type: standard, oversize, short-slot, long-slot, or other
 - (e) Hole fabrication method: drilling, punching, sub-punching and reaming, or other
 - (f) Other parameters pertinent to the specific connection under consideration
- (7) Workmanship: All workmanship parameters that exceed AISC, RCSC and AWS requirements, pertinent to the specific connection under consideration, such as:
- (a) Surface roughness of thermal cut or ground edges.
 - (b) Cutting tolerances.
 - (c) Weld reinforcement or contouring.
 - (d) Presence of holes, fasteners or welds for attachments.
- (8) Additional connection details:
- All variables pertinent to the specific connection under consideration, as established by the CPRP.

N.5 Design Procedure

A comprehensive design procedure must be available for a prequalified connection. The design procedure must address all applicable limit states within the limits of prequalification.

N.6 Prequalification Record

A prequalified connection shall be provided with a written prequalification record with the following information:

- (a) General description of the prequalified connection and drawings that clearly identify key features and components of the connection.
- (b) Description of the expected behavior of the connection in the elastic and inelastic ranges of behavior, intended location(s) of inelastic action, and a description of limit states controlling the strength and deformation capacity of the connection.
- (c) Listing of systems for which connection is prequalified: SMF, IMF, or EBF
- (d) Listing of limits for all prequalification variables listed in Section N.4.
- (e) Listing of demand critical welds.
- (f) Definition of the region of the connection that comprises of the protected zone.
- (g) Detailed description of the design procedure for the connection, as required in Section N.5.
- (h) List of references of test reports, research reports and other publications that provided the basis for prequalification.
- (i) Summary of quality control and quality assurance procedures.

PART VI
Appendix O
Quality Assurance Plan

O.1 Scope

Quality control (QC) and quality assurance (QA) shall be provided as specified in this Section.

O.2 Inspection and Nondestructive Testing Personnel

Visual welding inspection and nondestructive testing (NDT) shall be conducted in accordance with a written practice by personnel qualified in accordance with Appendix S.

Bolting inspection shall be conducted in accordance with a written practice by qualified personnel.

O.3 Contractor Documents

The following documents shall be submitted for review by the engineer of record or designee, prior to fabrication or erection, as applicable:

- (1) Shop drawings.
- (2) Erection drawings.
- (3) Welding Procedure Specifications (WPS), which shall specify all applicable essential variables of AWS D1.1 and the following, as applicable.
 - (a) power source (constant current or constant voltage).
 - (b) for demand critical welds, electrode manufacturer and trade name.
- (4) Copies of the manufacturer's typical certificate of conformance for all electrodes, fluxes and shielding gasses to be used. Certificates of conformance shall satisfy the applicable AWS A5 requirements.
- (5) For demand critical welds, applicable manufacturer's certifications that the filler metal meets the supplemental notch toughness requirements, as applicable. Should the filler metal manufacturer not supply such supplemental certifications, the contractor shall have the necessary testing performed and provide the applicable test reports.
- (6) Manufacturer's product data sheets or catalog data for SMAW, FCAW and GMAW composite (cored) filler metals to be used. The data sheets shall describe the product, limitations of use, recommended or typical welding parameters, and storage and exposure requirements, including baking, if applicable.

The following documents shall be available for review by the engineer of record or designee prior to fabrication or erection, as applicable, unless specified to be submitted:

- (1) Material test reports for structural steel, bolts, shear connectors, and welding materials.
- (2) Inspection procedures.
- (3) Nonconformance procedure.
- (4) Material control procedure.
- (5) Bolt installation procedure.
- (6) Welder performance qualification records (WPQR), including any supplemental testing requirements.
- (7) QC Inspector qualifications.

O.4 Quality Assurance Agency Documents

The agency responsible for quality assurance shall submit the following documents to the authority having jurisdiction, the engineer of record, and the owner or owner's designee:

- (1) QA agency's written practices for the monitoring and control of the agency's operations. The written practice shall include:
 - (a) The agency's procedures for the selection and administration of inspection personnel, describing the training, experience and examination requirements for qualification and certification of inspection personnel, and
 - (b) The agency's inspection procedures, including general inspection, material controls, and visual welding inspection.
- (2) Qualifications of management and QA personnel designated for the project.
- (3) Qualification records for Inspectors and NDT technicians designated for the project.
- (4) NDT procedures and equipment calibration records for NDT to be performed and equipment to be used for the project.
- (5) Daily or weekly inspection reports.
- (6) Nonconformance reports.

O.5 Inspection Points and Frequencies

Inspection points and frequencies of quality control (QC) and quality assurance (QA) tasks and documentation for the seismic load resisting system (SLRS) shall be as provided in the following Tables.

The following entries are used in the Tables:

Observe (O) - The inspector shall observe these functions on a random, daily basis. Welding operations need not be delayed pending observations.

Perform (P) - These inspections shall be performed prior to the final acceptance of the item. Where a task is noted to be performed by both QC and QA, it shall be permitted to coordinate the inspection function between QC and QA so that the inspection functions need be performed by only one party. Where QA is to rely upon inspection functions performed by QC, the approval of the engineer of record and the authority having jurisdiction is required.

Document (D) - The inspector shall prepare reports indicating that the work has been performed in accordance with the contract documents. The report need not provide detailed measurements for joint fit-up, WPS settings, completed welds, or other individual items listed in the Tables in Sections O.5.1, O.5.3, or O.5.4. For shop fabrication, the report shall indicate the piece mark of the piece inspected. For field work, the report shall indicate the reference grid lines and floor or elevation inspected. Work not in compliance with the contract documents and whether the noncompliance has been satisfactorily repaired shall be noted in the inspection report.

O.5.1 Visual Welding Inspection

Visual inspection of welding shall be the primary method used to confirm that the procedures, materials, and workmanship incorporated in construction are those that have been specified and approved for the project. As a minimum, welding inspection tasks shall be as follows:

Table 6.O.1: Visual Welding Inspection Tasks

Visual Inspection Tasks Before Welding	QC		QA	
	Task	Doc.	Task	Doc.
Material identification (Type/Grade)	O	–	O	–
Fit-up of Groove Welds (including joint geometry)	P/O**	–	O	–
– Joint preparation				
– Dimensions (alignment, root opening, root face, bevel)				
– Cleanliness (condition of steel surfaces)				
– Tacking (tack weld quality and location)				
– Backing type and fit (if applicable)				
Configuration and finish of access holes	O	–	O	–
Fit-up of Fillet Welds	P/O**	–	O	–
– Dimensions (alignment, gaps at root)				
– Cleanliness (condition of steel surfaces)				
– Tacking (tack weld quality and location)				
<p>** Following performance of this inspection task for ten welds to be made by a given welder, with the welder demonstrating adequate understanding of requirements and possession of skills and tools to verify these items, the Perform designation of this task shall be reduced to Observe, and the welder shall perform this task. Should the inspector determine that the welder has discontinued adequate performance of this task, the task shall be returned to Perform until such time as the Inspector has reestablished adequate assurance that the welder will perform the inspection tasks listed.</p>				

Visual Inspection Tasks During Welding	QC		QA	
	Task	Doc.	Task	Doc.
WPS followed	O	-	O	-
- Settings on welding equipment				
- Travel speed				
- Selected welding materials				
- Shielding gas type/flow rate				
- Preheat applied				
- Interpass temperature maintained (min./max.)				
- Proper position (F, V, H, OH)				
- Intermix of filler metals avoided unless approved				
Use of qualified welders	O	-	O	-
Control and handling of welding consumables	O	-	O	-
- Packaging				
- Exposure control				
Environmental conditions	O	-	O	-
- Wind speed within limits				
- Precipitation and temperature				
Welding techniques	O	-	O	-
- Interpass and final cleaning				
- Each pass within profile limitations				
- Each pass meets quality requirements				
No welding over cracked tacks	O	-	O	-

Visual Inspection Tasks After Welding	QC		QA	
	Task	Doc.	Task	Doc.
Welds cleaned	O	-	O	-
Welder identification legible	O	-	O	-
Verify size, length, and location of welds	O	-	O	-
Visually inspect welds to acceptance criteria	P	D	P	D
- Crack prohibition				
- Weld/base-metal fusion				
- Crater cross-section				
- Weld profiles				
- Weld size				
- Undercut				
- Porosity				
Placement of reinforcement fillets	P	D	P	D
Backing bars removed and weld tabs removed and finished (if required)	P	D	P	D
Repair activities	P	-	P	D

O.5.2 Nondestructive Testing (NDT) of Welds

Nondestructive testing of welds shall be performed by quality assurance personnel.

(1) Procedures

Ultrasonic testing shall be performed by QA according to the procedures prescribed in Appendix S, Sec S.4.1.

Magnetic particle testing shall be performed by QA according to procedures prescribed in Appendix S, Sec S.4.2.

(2) Required NDT**(a) k-Area NDT**

When welding of doubler plates, continuity plates, or stiffeners has been performed in the k-area, the web shall be tested for cracks using magnetic particle testing (MT). The MT inspection area shall include the k-area base metal within 75 mm of the weld.

(b) CJP Groove Weld NDT

Ultrasonic testing shall be performed on 100 percent of CJP groove welds in materials 8 mm thick or greater. Ultrasonic testing in materials less than 8 mm thick is not required. Magnetic particle testing shall be performed on 25 percent of all beam-to-column CJP groove welds.

(c) Base Metal NDT for Lamellar Tearing and Laminations

After joint completion, base metal thicker than 38 mm loaded in tension in the through thickness direction in tee and corner joints, where the connected material is greater than 19 mm and contains CJP groove welds, shall be ultrasonically tested for discontinuities behind and adjacent to the fusion line of such welds. Any base metal discontinuities found within $t/4$ of the steel surface shall be accepted or rejected on the basis of criteria of AWS D1.1 Table 6.2, where t is the thickness of the part subjected to the through-thickness strain.

(d) Beam Cope and Access Hole NDT

At welded splices and connections, thermally cut surfaces of beam copes and access holes shall be tested using magnetic particle testing or penetrant testing, when the flange thickness exceeds 38 mm for rolled shapes, or when the web thickness exceeds 38 mm for built-up shapes.

(e) Reduced Beam Section Repair NDT

Magnetic particle testing shall be performed on any weld and adjacent area of the reduced beam section (RBS) plastic hinge region that has been repaired by welding, or on the base metal of the RBS plastic hinge region if a sharp notch has been removed by grinding.

(f) Weld Tab Removal Sites

Magnetic particle testing shall be performed on the end of welds from which the weld tabs have been removed, except for continuity plate weld tabs.

(g) Reduction of Percentage of Ultrasonic Testing

The amount of ultrasonic testing is permitted to be reduced if approved by the engineer of record and the authority having jurisdiction. The nondestructive testing rate for an individual welder or welding operator may be reduced to 25 percent, provided the reject rate is demonstrated to be 5 percent or less of the welds tested for the welder or welding operator. A sampling of at least 40 completed welds for a job shall be made for such reduction evaluation. Reject rate is the number of welds containing rejectable defects divided by the number of welds completed. For evaluating the reject rate of continuous welds over 1 m in length where the effective throat thickness is 25 mm or less, each 300 mm increment or fraction thereof shall be considered as one weld. For evaluating the reject rate on continuous welds over 1 m in length where the effective throat thickness is greater than 25 mm, each 150 mm of length or fraction thereof shall be considered one weld.

(h) Reduction of Percentage of Magnetic Particle Testing

The amount of MT on CJP groove welds is permitted to be reduced if approved by the engineer of record and the authority having jurisdiction. The MT rate for an individual welder or welding operator may be reduced to 10 percent, provided the reject rate is demonstrated to be 5 percent or less of the welds tested for the welder or welding operator. A sampling of at least 20 completed welds for a job shall be made for such reduction evaluation. Reject rate is the number of welds containing rejectable defects divided by the number of welds completed. This reduction is not permitted on welds in the k-area, at repair sites, weld tab and backing removal sites and access holes.

(3) Documentation

All NDT performed shall be documented. For shop fabrication, the NDT report shall identify the tested weld by piece mark and location in the piece. For field work, the NDT report shall identify the tested weld by location in the structure, piece mark, and location in the piece.

O.5.3 Inspection of Bolting

Observation of bolting operations shall be the primary method used to confirm that the procedures, materials, and workmanship incorporated in construction are those that have been specified and approved for the project. As a minimum, the tasks shall be as follows:

Inspection Tasks Prior to Bolting	QC		QA	
	Task	Doc.	Task	Doc.
Proper bolts selected for the joint detail	O	–	O	–
Proper bolting procedure selected for joint detail	O	–	O	–
Connecting elements are fabricated properly, including the appropriate faying surface condition and hole preparation, if specified, meets applicable requirements	O	–	O	–
Pre-installation verification testing conducted for fastener assemblies and methods used	P	D	O	D
Proper storage provided for bolts, nuts, washers, and other fastener components	O	–	O	–

Inspection Tasks During Bolting	QC		QA	
	Task	Doc.	Task	Doc.
Fastener assemblies placed in all holes and washers (if required) are properly positioned	O	–	O	–
Joint brought to the snug tight condition prior to the pretensioning operation	O	–	O	–
Fastener component not turned by the wrench prevented from rotating	O	–	O	–
Bolts are pretensioned progressing systematically from most rigid point toward free edges	O	–	O	–

Inspection Tasks After Bolting	QC		QA	
	Task	Doc.	Task	Doc.
Document accepted and rejected connections	P	D	P	D

O.5.4 Other Inspections

Where applicable, the following inspection tasks shall be performed:

Other Inspection Task	QC		QA	
	Task	Doc.	Task	Doc.
Reduced beam section (RBS) requirements, if applicable	P	D	P	D
– contour and finish				
– dimensional tolerances				
Protected zone – no holes and unapproved attachments made by contractor	P	D	P	D

PART VI
Appendix P

Seismic Design Coefficients and Approximate Period Parameters

P.1 Scope

This appendix contains design coefficients, system limitations and design parameters for seismic load resisting systems (SLRS) that are included in these provisions but not yet defined in the applicable building code for buckling-restrained braced frames (BRBF) and special plate shear walls (SPSW). The values presented in Tables 6.P.1 and 6.P.2 in this Appendix shall only be used where neither the applicable building code nor SEI/ASCE 7 contain such values.

P.2 Symbols

The following symbols are used in this appendix.

- C_d Deflection amplification factor
 C_r, x Parameters used for determining the approximate fundamental period
 Ω_0 System overstrength factor
 R Response modification coefficient

P.3 Coefficients and Factors for Basic Seismic Load Resisting Systems**TABLE 6.P.1 Design Coefficients and Factors for Basic Seismic Load Resisting Systems**

Basic Seismic Load Resisting System	Response Modification/Reduction Coefficient R	System Overstrength Factor Ω_0	Deflection Amplification Factor C_d	Height Limit (m)	
				Seismic Design Category	
				B & C	D
Building Frame Systems					
Buckling-Restrained Braced Frames, non-moment-resisting beam-column connections	7	2	5½	NL	48
Special Plate Shear Walls	7	2	6	NL	48
Buckling-Restrained Braced Frames, moment-resisting beam-column connections	8	2½	5	NL	48
Dual Systems with Special Moment Frames Capable of Resisting at Least 25% of the Prescribed Seismic Forces					
Buckling-Restrained Braced Frame	8	2½	5	NL	NL
Special Plate Shear Walls	8	2½	6½	NL	NL

(NL = Not Limited)

P.4 VALUES OF APPROXIMATE PERIOD PARAMETERS**Table 6.P.2 Values of Approximate Period Parameters C_r and x**

Structure Type	C_r	x
Buckling-Restrained Braced Frames	0.03	0.75
Special Plate Shear Walls	0.02	0.75

PART VI
Appendix Q
Qualifying Cyclic Tests of Beam-to-Column and
Link-to-Column Connections

Q.1 Scope

This Appendix includes requirements for qualifying cyclic tests of beam-to-column moment connections in special and intermediate moment frames and link-to-column connections in eccentrically braced frames, when required in these Provisions. The purpose of the testing described in this Appendix is to provide evidence that a beam-to-column connection or a link-to-column connection satisfies the requirements for strength and interstory drift angle or link rotation angle in these Provisions. Alternative testing requirements are permitted when approved by the engineer of record and the authority having jurisdiction.

This Appendix provides minimum recommendations for simplified test conditions.

Q.2 Symbols

The numbers in parentheses after the definition of a symbol refers to the Section number in which the symbol is first used.

- θ Interstory drift angle (Q.6)
 γ_{total} Total link rotation angle (Q.6)

Q.3 Definitions

Complete loading cycle: A cycle of rotation taken from zero force to zero force, including one positive and one negative peak.

Interstory drift angle: Interstory displacement divided by story height, radians.

Inelastic rotation: The permanent or plastic portion of the rotation angle between a beam and the column or between a link and the column of the test specimen, measured in radians. The inelastic rotation shall be computed based on an analysis of test specimen deformations. Sources of inelastic rotation include yielding of members, yielding of connection elements and connectors, and slip between members and connection elements. For beam-to-column moment connections in special and intermediate moment frames, inelastic rotation is computed based upon the assumption that inelastic action is concentrated at a single point located at the intersection of the centerline of the beam with the centerline of the column. For link-to-column connections in eccentrically braced frames, inelastic rotation shall be computed based upon the assumption that inelastic action is concentrated at a single point located at the intersection of the centerline of the link with the face of the column.

Prototype : The connections, member sizes, steel properties, and other design, detailing, and construction features to be used in the actual building frame.

Test specimen : A portion of a frame used for laboratory testing, intended to model the prototype.

Test setup : The supporting fixtures, loading equipment, and lateral bracing used to support and load the test specimen.

Test subassemblage : The combination of the test specimen and pertinent portions of the test setup.

Total link rotation angle : The relative displacement of one end of the link with respect to the other end (measured transverse to the longitudinal axis of the undeformed link), divided by the link length. The total link rotation angle shall include both elastic and inelastic components of deformation of the link and the members attached to the link ends.

Q.4 Test Subassemblage Requirements

The test subassemblage shall replicate as closely as is practical the conditions that will occur in the prototype during earthquake loading. The test subassemblage shall include the following features :

- (1) The test specimen shall consist of at least a single column with beams or links attached to one or both sides of the column.
- (2) Points of inflection in the test assemblage shall coincide approximately with the anticipated points of inflection in the Prototype under earthquake loading.
- (3) Lateral bracing of the test subassemblage is permitted near load application or reaction points as needed to provide lateral stability of the test subassemblage. Additional lateral bracing of the test subassemblage is not permitted, unless it replicates lateral bracing to be used in the prototype.

Q.5 Essential Test Variables

The test specimen shall replicate as closely as is practical the pertinent design, detailing, construction features, and material properties of the prototype. The following variables shall be replicated in the test specimen.

Q.5.1 Sources of Inelastic Rotation

Inelastic rotation shall be developed in the test specimen by inelastic action in the same members and connection elements as anticipated in the prototype (in other words, in the beam or link, in the column panel zone, in the column outside of the panel zone, or in connection elements) within the limits described below. The percentage of the total inelastic rotation in the test specimen that is developed in each member or connection element shall be within 25 percent of the anticipated percentage of the total inelastic rotation in the prototype that is developed in the corresponding member or connection element.

Q.5.2 Size of Members

The size of the beam or link used in the test specimen shall be within the following limits:

- (1) The depth of the test beam or link shall be no less than 90 percent of the depth of the prototype beam or link.
- (2) The weight per foot of the test beam or link shall be no less than 75 percent of the weight per foot of the prototype beam or link.

The size of the column used in the test specimen shall properly represent the inelastic action in the column, as per the requirements in Section Q.5.1. In addition, the depth of the test column shall be no less than 90 percent of the depth of the prototype column.

Extrapolation beyond the limitations stated in this Section shall be permitted subject to qualified peer review and approval by the authority having jurisdiction.

Q.5.3 Connection Details

The connection details used in the test specimen shall represent the prototype connection details as closely as possible. The connection elements used in the test specimen shall be a full-scale representation of the connection elements used in the prototype, for the member sizes being tested.

Q.5.4 Continuity Plates

The size and connection details of continuity plates used in the test specimen shall be proportioned to match the size and connection details of continuity plates used in the prototype connection as closely as possible.

Q.5.5 Material Strength

The following additional requirements shall be satisfied for each member or connection element of the test specimen that supplies inelastic rotation by yielding:

- (1) The yield stress shall be determined by material tests on the actual materials used for the test specimen, as specified in Section Q.8. The use of yield stress values that are reported on certified mill test reports are not permitted to be used for purposes of this Section.

The yield stress of the beam shall not be more than 15 percent below R_y F_y for the grade of steel to be used for the corresponding elements of the prototype. Columns and connection elements with a tested yield stress shall not be more than 15 percent above or below R_y F_y for the grade of steel to be used for the corresponding elements of the prototype. R_y F_y shall be determined in accordance with Section Q.6.2.

Q.5.6 Welds

Welds on the test specimen shall satisfy the following requirements :

- (1) Welding shall be performed in strict conformance with Welding Procedure Specifications (WPS) as required in AWS D1.1. The WPS essential variables shall meet the requirements in AWS D1.1 and shall be within the parameters established by the filler-metal manufacturer. The tensile strength of the welds used in the tested assembly and the Charpy V-Notch (CVN) toughness used in the tested assembly shall be determined by material tests as specified in Section Q.8.3. The use of tensile strength and CVN toughness values that are reported on the manufacturer's typical certificate of conformance is not permitted to be used for purposes of this Section, unless the report includes results specific to Appendix T requirements.
- (2) The specified minimum tensile strength of the filler metal used for the test specimen shall be the same as that to be used for the corresponding prototype welds. The tested tensile strength of the test specimen weld shall not be more than 125 MPa above the tensile strength classification of the filler metal specification specified for the prototype.
- (3) The specified minimum CVN toughness of the filler metal used for the test specimen shall not exceed the specified minimum CVN toughness of the filler metal to be used for the corresponding prototype welds. The tested CVN toughness of the test specimen weld shall not be more than 50 percent, nor 34 kJ, whichever is greater, above the minimum CVN toughness that will be specified for the prototype.
- (4) The welding positions used to make the welds on the test specimen shall be the same as those to be used for the prototype welds.
- (5) Details of weld backing, weld tabs, access holes, and similar items used for the test specimen welds shall be the same as those to be used for the corresponding prototype welds. Weld backing and weld tabs shall not be removed from the test specimen welds unless the corresponding weld backing and weld tabs are removed from the prototype welds.
- (6) Methods of inspection and nondestructive testing and standards of acceptance used for test specimen welds shall be the same as those to be used for the prototype welds.

Q.5.7 Bolts

The bolted portions of the test specimen shall replicate the bolted portions of the prototype connection as closely as possible. Additionally, bolted portions of the test specimen shall satisfy the following requirements :

- (1) The bolt grade (for example, ASTM A325, A325M, ASTM A490, A490M, ASTM F1852) used in the test specimen shall be the same as that to be used for the prototype, except that ASTM A325 bolts may be substituted for ASTM F1852 bolts, and vice versa.

- (2) The type and orientation of bolt holes (standard, oversize, short slot, long slot, or other) used in the test specimen shall be the same as those to be used for the corresponding bolt holes in the prototype.
- (3) When inelastic rotation is to be developed either by yielding or by slip within a bolted portion of the connection, the method used to make the bolt holes (drilling, sub-punching and reaming, or other) in the test specimen shall be the same as that to be used in the corresponding bolt holes in the prototype.
- (4) Bolts in the test specimen shall have the same installation (pretensioned or other) and faying surface preparation (no specified slip resistance, Class A or B slip resistance, or other) as that to be used for the corresponding bolts in the prototype.

Q.6 LOADING HISTORY

Q.6.1 General Requirements

The test specimen shall be subjected to cyclic loads according to the requirements prescribed in Section Q.6.2 for beam-to-column moment connections in special and intermediate moment frames, and according to the requirements prescribed in Section Q.6.3 for link-to-column connections in eccentrically braced frames.

Loading sequences other than those specified in Sections Q.6.2 and Q.6.3 may be used when they are demonstrated to be of equivalent or greater severity.

Q.6.2 Loading Sequence for Beam-to-Column Moment Connections

Qualifying cyclic tests of beam-to-column moment connections in special and intermediate moment frames shall be conducted by controlling the interstory drift angle, θ , imposed on the test specimen, as specified below:

- (1) 6 cycles at $\theta = 0.00375$ rad
- (2) 6 cycles at $\theta = 0.005$ rad
- (3) 6 cycles at $\theta = 0.0075$ rad
- (4) 4 cycles at $\theta = 0.01$ rad
- (5) 2 cycles at $\theta = 0.015$ rad
- (6) 2 cycles at $\theta = 0.02$ rad
- (7) 2 cycles at $\theta = 0.03$ rad
- (8) 2 cycles at $\theta = 0.04$ rad

Continue loading at increments of $\theta = 0.01$ radian, with two cycles of loading at each step.

Q.6.3 Loading Sequence for Link-to-Column Connections

Qualifying cyclic tests of link-to-column moment connections in eccentrically braced frames shall be conducted by controlling the total link rotation angle, γ_{total} , imposed on the test specimen, as follows :

- (1) 6 cycles at $\gamma_{total} = 0.00375$ rad
- (2) 6 cycles at $\gamma_{total} = 0.005$ rad
- (3) 6 cycles at $\gamma_{total} = 0.0075$ rad
- (4) 6 cycles at $\gamma_{total} = 0.01$ rad
- (5) 4 cycles at $\gamma_{total} = 0.015$ rad
- (6) 4 cycles at $\gamma_{total} = 0.02$ rad
- (7) 2 cycles at $\gamma_{total} = 0.03$ rad
- (8) 1 cycle at $\gamma_{total} = 0.04$ rad
- (9) 1 cycle at $\gamma_{total} = 0.05$ rad
- (10) 1 cycle at $\gamma_{total} = 0.07$ rad
- (11) 1 cycle at $\gamma_{total} = 0.09$ rad

Continue loading at increments of $\gamma_{total} = 0.02$ radian, with one cycle of loading at each step.

Q.7 Instrumentation

Sufficient instrumentation shall be provided on the test specimen to permit measurement or calculation of the quantities listed in Section Q.9.

Q.8 Materials Testing Requirements**Q.8.1 Tension Testing Requirements for Structural Steel**

Tension testing shall be conducted on samples of steel taken from the material adjacent to each test specimen. Tension-test results from certified mill test reports shall be reported but are not permitted to be used in place of specimen testing for the purposes of this Section. Tension-test results shall be based upon testing that is conducted in accordance with Section Q.8.2. Tension testing shall be conducted and reported for the following portions of the test specimen:

- (1) Flange(s) and web(s) of beams and columns at standard locations
- (2) Any element of the connection that supplies inelastic rotation by yielding

Q.8.2 Methods of Tension Testing for Structural Steel

Tension testing shall be conducted in accordance with ASTM A6/A6M, ASTM A370, and ASTM E8, with the following exceptions:

- (1) The yield stress, F_y , that is reported from the test shall be based upon the yield strength definition in ASTM A370, using the offset method at 0.002 strain.
- (2) The loading rate for the tension test shall replicate, as closely as practical, the loading rate to be used for the test specimen.

Q.8.3 Weld Metal Testing Requirements

The tensile strength of the welds used in the tested assembly and the CVN toughness used in the tested assembly shall be determined by material tests as specified in Appendix T. The use of tensile strength and CVN toughness values that are reported on the manufacturer's typical certificate of conformance is not permitted to be used for purposes of this section, unless that report includes results specific to Appendix T requirements.

A single test plate may be used if the WPS for the test specimen welds is within plus/minus 0.8 kJ/mm of the WPS for the test plate.

Tensile specimens and CVN specimens shall be prepared in accordance with ANSI/AWS B4.0 Standard Methods for Mechanical Testing of Welds.

Q.9 Test Reporting Requirements

For each test specimen, a written test report meeting the requirements of the *authority having jurisdiction* and the requirements of this Section shall be prepared. The report shall thoroughly document all key features and results of the test. The report shall include the following information :

- (1) A drawing or clear description of the test subassembly, including key dimensions, boundary conditions at loading and reaction points, and location of lateral braces.
- (2) A drawing of the connection detail showing member sizes, grades of steel, the sizes of all connection elements, welding details including filler metal, the size and location of bolt holes, the size and grade of bolts, and all other pertinent details of the connection.
- (3) A listing of all other essential variables for the test specimen, as listed in Section Q.5.
- (4) A listing or plot showing the applied load or displacement history of the test specimen.
- (5) A listing of all demand critical welds.

- (6) Definition of the region of the connection that comprises the protected zones.
- (7) A plot of the applied load versus the displacement of the test specimen. The displacement reported in this plot shall be measured at or near the point of load application. The locations on the test specimen where the loads and displacements were measured shall be clearly indicated.
- (8) A plot of beam moment versus interstory drift angle for beam-to-column moment connections; or a plot of link shear force versus link rotation angle for link-to-column connections. For beam-to-column connections, the beam moment and the interstory drift angle shall be computed with respect to the centerline of the column.
- (9) The interstory drift angle and the total inelastic rotation developed by the test specimen. The components of the test specimen contributing to the total inelastic rotation due to yielding or slip shall be identified. The portion of the total inelastic rotation contributed by each component of the test specimen shall be reported. The method used to compute inelastic rotations shall be clearly shown.
- (10) A chronological listing of significant test observations, including observations of yielding, slip, instability, and fracture of any portion of the test specimen as applicable.
- (11) The controlling failure mode for the test specimen. If the test is terminated prior to failure, the reason for terminating the test shall be clearly indicated.
- (12) The results of the material tests specified in Section Q.8.
- (13) The Welding Procedure Specifications (WPS) and welding inspection reports.

Additional drawings, data, and discussion of the test specimen or test results are permitted to be included in the report.

Q.10 Acceptance Criteria

The test specimen must satisfy the strength and interstory drift angle or link rotation angle requirements of these Provisions for the special moment frame, intermediate moment frame, or eccentrically braced frame connection, as applicable. The test specimen must sustain the required interstory drift angle or link rotation angle for at least one complete loading cycle.

PART VI
Appendix R

Qualifying Cyclic Tests of Buckling-restrained Braces

R.1 Scope

This Appendix includes requirements for qualifying cyclic tests of individual buckling-restrained braces and buckling-restrained brace subassemblies, when required in these provisions. The purpose of the testing of individual braces is to provide evidence that a buckling-restrained brace satisfies the requirements for strength and inelastic deformation by these provisions; it also permits the determination of maximum brace forces for design of adjoining elements. The purpose of testing of the brace subassembly is to provide evidence that the brace-design can satisfactorily accommodate the deformation and rotational demands associated with the design. Further, the subassembly test is intended to demonstrate that the hysteretic behavior of the brace in the subassembly is consistent with that of the individual brace elements tested uniaxially.

Alternative testing requirements are permitted when approved by the engineer of record and the authority having jurisdiction. This Appendix provides only minimum recommendations for simplified test conditions.

R.2 Symbols

The numbers in parentheses after the definition of a symbol refers to the Section number in which the symbol is first used.

- Δ_b Deformation quantity used to control loading of the test specimen (total brace end rotation for the subassembly test specimen; total brace axial deformation for the brace test specimen) (Section R.6).
- $\Delta_{b,dr}$ Value of deformation quantity, Δ_b , corresponding to the design story drift (Section R.6).
- $\Delta_{b,y}$ Value of deformation quantity, Δ_b , at first significant yield of test specimen (Section R.6).

R.3 Definitions

BRACE TEST SPECIMEN	A single buckling-restrained brace element used for laboratory testing intended to model the brace in the Prototype.
DESIGN METHODOLOGY	A set of step-by-step procedures, based on calculation or experiment, used to determine sizes, lengths, and details in the design of buckling-restrained braces and their connections.

INELASTIC DEFORMATION	The permanent or plastic portion of the axial displacement in a buckling-restrained brace.
PROTOTYPE	The brace, connections, members, steel properties, and other design, detailing, and construction features to be used in the actual building frame.
SUBASSEMBLAGE TEST SPECIMEN	The combination of the brace, the connections and testing apparatus that replicate as closely as practical the axial and flexural deformations of the brace in the prototype.
TEST SPECIMEN	Brace test specimen or subassembly test specimen.

R.4 Subassembly Test Specimen

The subassembly test specimen shall satisfy the following requirements :

- (1) The mechanism for accommodating inelastic rotation in the subassembly test specimen brace shall be the same as that of the prototype. The rotational deformation demands on the subassembly test specimen brace shall be equal to or greater than those of the prototype.
- (2) The axial yield strength of the steel core, $F_{y,sc}$, of the brace in the subassembly test specimen shall not be less than that of the prototype where both strengths are based on the core area, A_{sc} , multiplied by the yield strength as determined from a coupon test.
- (3) The cross-sectional shape and orientation of the steel core projection of the subassembly test specimen brace shall be the same as that of the brace in the prototype.
- (4) The same documented design methodology shall be used for design of the subassembly as used for the prototype, to allow comparison of the rotational deformation demands on the subassembly brace to the prototype. In stability calculations, beams, columns, and gussets connecting the core shall be considered parts of this system.
- (5) The calculated margins of safety for the prototype connection design, steel core projection stability, overall buckling and other relevant subassembly test specimen brace construction details, excluding the gusset plate, for the prototype, shall equal or exceed those of the subassembly test specimen construction.
- (6) Lateral bracing of the subassembly test specimen shall replicate the lateral bracing in the prototype.
- (7) The brace test specimen and the prototype shall be manufactured in accordance with the same quality control and assurance processes and procedures.

Extrapolation beyond the limitations stated in this section shall be permitted subject to qualified peer review and approval by the authority having jurisdiction.

R.5 Brace Test Specimen

The brace test specimen shall replicate as closely as is practical the pertinent design, detailing, construction features, and material properties of the prototype.

R.5.1 Design of Brace Test Specimen

The same documented design methodology shall be used for the brace test specimen and the prototype. The design calculations shall demonstrate, at a minimum, the following requirements :

- (1) The calculated margin of safety for stability against overall buckling for the prototype shall equal or exceed that of the brace test specimen.
- (2) The calculated margins of safety for the brace test specimen and the prototype shall account for differences in material properties, including yield and ultimate stress, ultimate elongation, and toughness.

R.5.2 Manufacture of Brace Test Specimen

The brace test specimen and the prototype shall be manufactured in accordance with the same quality control and assurance processes and procedures.

R.5.3 Similarity of Brace Test Specimen and Prototype

The brace test specimen shall meet the following requirements:

- (1) The cross-sectional shape and orientation of the steel core shall be the same as that of the prototype.
- (2) The axial yield strength of the steel core, P_{JSC} , of the brace test specimen shall not vary by more than 50 percent from that of the prototype where both strengths are based on the core area, A_{SC} , multiplied by the yield strength as determined from a coupon test.
- (3) The material for, and method of, separation between the steel core and the buckling restraining mechanism in the brace test specimen shall be the same as that in the prototype.

Extrapolation beyond the limitations stated in this section shall be permitted subject to qualified peer review and approval by the authority having jurisdiction.

R.5.4 Connection Details

The connection details used in the brace test specimen shall represent the prototype connection details as closely as practical.

R.5.5 Materials

- (1) Steel core: The following requirements shall be satisfied for the steel core of the brace test specimen:
 - (a) The specified minimum yield stress of the brace test specimen steel core shall be the same as that of the prototype.

- (b) The measured yield stress of the material of the steel core in the brace test specimen shall be at least 90 percent of that of the prototype as determined from coupon tests.
- (c) The specified minimum ultimate stress and strain of the brace test specimen steel core shall not exceed those of the prototype.

(2) Buckling-restraining mechanism

Materials used in the buckling-restraining mechanism of the brace test specimen shall be the same as those used in the prototype.

R.5.6 Connections

The welded, bolted, and pinned joints on the test specimen shall replicate those on the prototype as close as practical.

R.6 Loading History

R.6.1 General Requirements

The test specimen shall be subjected to cyclic loads according to the requirements prescribed in Sections R.6.2 and R.6.3. Additional increments of loading beyond those described in Section R.6.3 are permitted. Each cycle shall include a full tension and full compression excursion to the prescribed deformation.

R.6.2 Test Control

The test shall be conducted by controlling the level of axial or rotational deformation, Δ_b , imposed on the test specimen. As an alternate, the maximum rotational deformation may be applied and maintained as the protocol is followed for axial deformation.

R.6.3 Loading Sequence

Loads shall be applied to the test specimen to produce the following deformations, where the deformation is the steel core axial deformation for the test specimen and the rotational deformation demand for the subassembly test specimen brace:

- (1) 2 cycles of loading at the deformation corresponding to $\Delta_b = \Delta_{by}$
- (2) 2 cycles of loading at the deformation corresponding to $\Delta_b = 0.5\Delta_{bm}$
- (3) 2 cycles of loading at the deformation corresponding to $\Delta_b = 1.0\Delta_{bm}$
- (4) 2 cycles of loading at the deformation corresponding to $\Delta_b = 1.5\Delta_{bm}$
- (5) 2 cycles of loading at the deformation corresponding to $\Delta_b = 2.0\Delta_{bm}$
- (6) Additional complete cycles of loading at the deformation corresponding to $\Delta_b = 1.5\Delta_{bm}$ as required for the brace test specimen to achieve a cumulative inelastic axial deformation of at least 200 times the yield deformation (not required for the subassembly test specimen).

The design story drift shall not be taken as less than 0.01 times the story height for the purposes of calculating Δ_{bm} . Other loading sequences are permitted to be used to qualify the test specimen when they are demonstrated to be of equal or greater severity in terms of maximum and cumulative inelastic deformation.

R.7 Instrumentation

Sufficient instrumentation shall be provided on the *test specimen* to permit measurement or calculation of the quantities listed in Section R.9.

R.8 Materials Testing Requirements T

R.8.1 Tension Testing Requirements

Tension testing shall be conducted on samples of steel taken from the same material as that used to manufacture the steel core. Tension test results from certified mill test reports shall be reported but are not permitted to be used in place of specimen testing for the purposes of this Section. Tension-test results shall be based upon testing that is conducted in accordance with Section R.8.2.

R.8.2 Methods of Tension Testing

Tension testing shall be conducted in accordance with ASTM A6, ASTM A370, and ASTM E8, with the following exceptions:

- (1) The yield stress that is reported from the test shall be based upon the yield strength definition in ASTM A370, using the offset method of 0.002 strain.
- (2) The loading rate for the tension test shall replicate, as closely as is practical, the loading rate used for the test specimen.
- (3) The coupon shall be machined so that its longitudinal axis is parallel to the longitudinal axis of the steel core.

R.9 Test Reporting Requirements

For each test specimen, a written test report meeting the requirements of this Section shall be prepared. The report shall thoroughly document all key features and results of the test. The report shall include the following information:

- (1) A drawing or clear description of the test specimen, including key dimensions, boundary conditions at loading and reaction points, and location of lateral bracing, if any.
- (2) A drawing of the connection details showing member sizes, grades of steel, the sizes of all connection elements, welding details including filler metal, the size and location of bolt or pin holes, the size and grade of connectors, and all other pertinent details of the connections.

- (3) A listing of all other essential variables as listed in Section R.4 or R.5, as appropriate.
- (4) A listing or plot showing the applied load or displacement history.
- (5) A plot of the applied load versus the deformation, Δ_b . The method used to determine the deformations shall be clearly shown. The locations on the test specimen where the loads and deformations were measured shall be clearly identified.
- (6) A chronological listing of significant test observations, including observations of yielding, slip, instability, transverse displacement along the test specimen and fracture of any portion of the test specimen and connections, as applicable.
- (7) The results of the material tests specified in Section R.8.
- (8) The manufacturing quality control and quality assurance plans used for the fabrication of the test specimen. These shall be included with the welding procedure specifications and welding inspection reports.

Additional drawings, data, and discussion of the test specimen or test results are permitted to be included in the report.

R.10 Acceptance Criteria

At least one subassembly test that satisfies the requirements of Section R.4 shall be performed. At least one brace test that satisfies the requirements of Section R.5, shall be performed. Within the required protocol range all tests shall satisfy the following requirements:

- (1) The plot showing the applied load vs. displacement history shall exhibit stable, repeatable behavior with positive incremental stiffness.
- (2) There shall be no fracture, brace instability or brace end connection failure.
- (3) For brace tests, each cycle to a deformation greater than Δ_{by} the maximum.
- (4) tension and compression forces shall not be less than the nominal strength of the core.
- (5) For brace tests, each cycle to a deformation greater than Δ_{by} the ratio of the maximum compression force to the maximum tension force shall not exceed 1.3.

Other acceptance criteria may be adopted for the brace test specimen or subassembly test specimen subject to qualified peer review and approval by the authority having jurisdiction.

PART VI
Appendix S
Welding Provisions

S.1 Scope

This Appendix provides additional details regarding welding and welding inspection, and is included on an interim basis pending adoption of such criteria by AWS or other accredited organization.

**S.2 STRUCTURAL DESIGN DRAWINGS AND SPECIFICATIONS,
SHOP DRAWINGS, AND ERECTION DRAWINGS**

S.2.1 Structural Design Drawings and Specifications

Structural design drawings and specifications shall include, as a minimum, the following information:

- (1) Locations where backup bars are required to be removed.
- (2) Locations where supplemental fillet welds are required when backing is permitted to remain.
- (3) Locations where fillet welds are used to reinforce groove welds or to improve connection geometry.
- (4) Locations where weld tabs are required to be removed.
- (5) Splice locations where tapered transitions are required.
- (6) The shape of weld access holes, if a special shape is required.
- (7) Joints or groups of joints in which a specific assembly order, welding sequence, welding technique or other special precautions are required.

S.2.2 Shop Drawings

Shop drawings shall include, as a minimum, the following information:

- (1) Access hole dimensions, surface profile and finish requirements.
- (2) Locations where backing bars are to be removed.
- (3) Locations where weld tabs are to be removed.
- (4) NDT to be performed by the fabricator, if any.

S.2.3 Erection Drawings

Erection drawings shall include, as a minimum, the following information:

- (1) Locations where backing bars to be removed.
- (2) Locations where supplemental fillets are required when backing is permitted to remain.
- (3) Locations where weld tabs are to be removed.
- (4) Those joints or groups of joints in which a specific assembly order, welding sequence, welding technique or other special precautions are required.

S.3 Personnel

S.3.1 QC Welding Inspectors

QC welding inspection personnel shall be associate welding inspectors (AWI) or higher, as defined in AWS B5.1 Standard for the Qualification of Welding Inspectors, or otherwise qualified under the provisions of AWS D1.1 Section 6.1.4 and to the satisfaction of the contractor's QC plan by the fabricator/erector.

S.3.2 QA Welding Inspectors

QA welding inspectors shall be welding inspectors (WI), or senior welding inspectors (SWI), as defined in AWS B5.1, except AWIs may be used under the direct supervision of WIs, on site and available when weld inspection is being conducted.

S.4 Nondestructive Testing Technicians

NDT technicians shall be qualified as follows:

- (1) In accordance with their employer's written practice which shall meet or exceed the criteria of the American Society for Nondestructive Testing, Inc. SNT TC-1A Recommended Practice for the Training and Testing of Nondestructive Personnel, or of ANSI/ASNT CP-189, Standard for the Qualification and Certification of Nondestructive Testing Personnel.
- (2) Ultrasonic testing for QA may be performed only by UT technicians certified as ASNT Level III through examination by the ASNT, or certified as Level II by their employer for flaw detection. If the engineer of record approves the use of flaw sizing techniques, UT technicians shall also be qualified and certified by their employer for flaw sizing.
- (3) Magnetic particle testing (MT) and dye penetrant testing (PT) for QA may be performed only by technicians certified as Level II by their employer, or certified as ASNT Level III through examination by the ASNT and certified by their employer.

S.5 Nondestructive Testing Procedures

S.5.1 Ultrasonic Testing

Ultrasonic testing shall be performed according to the procedures prescribed in AWS D1.1 (Section 6, Part F) following a written procedure containing the elements prescribed in paragraph K3 of Annex K, Section 6, Part F (AWS) procedures shall be qualified using weld mock-ups having 1.5 mm diameter side drilled holes similar to Annex K, Figure K-3 (AWS).

S.5.2 Magnetic Particle Testing

Magnetic particle testing shall be performed according to procedures prescribed in AWS D1.1, following a written procedure utilizing the Yoke Method that conforms to ASTM E709.

S.6 Additional Welding Provisions

S.6.1 Intermixed Filler Metals

When FCAW-S filler metals are used in combination with filler metals of other processes, including FCAW-G, a test specimen shall be prepared and mechanical testing shall be conducted to verify that the notch toughness of the combined materials in the intermixed region of the weld meets the notch toughness requirements of Section 10.20.7.3.1 and, if required, the notch toughness requirements for demand critical welds of Section 10.20.7.3.2.

S.6.2 Filler Metal Diffusible Hydrogen

Welding electrodes and electrode-flux combinations shall meet the requirements for H16 (16 mL maximum diffusible hydrogen per 100 grams deposited weld metal) as tested in accordance with AWS A4.3 Standard Methods for Determination of the Diffusible Hydrogen Content of Martensitic, Bainitic, and Ferritic Steel Weld Metal Produced by Arc Welding. (Exception: GMAW solid electrodes.) The manufacturer's typical certificate of conformance shall be considered adequate proof that the supplied electrode or electrode-flux combination meets this requirement. No testing of filler metal samples or of production welds shall be required.

S.6.3 Gas-Shielded Welding Processes

GMAW and FCAW-G shall not be performed in winds exceeding 5 km/hr. Windscreens or other shelters may be used to shield the welding operation from excessive wind.

S.6.4 Maximum Interpass Temperatures

Maximum interpass temperatures shall not exceed 290 °C, measured at a distance not exceeding 75 mm from the start of the weld pass. The maximum interpass temperature may be increased by qualification testing that includes weld metal and base metal CVN testing using AWS D1.1 Annex III. The steel used for the qualification testing shall be of the same type and grade as will be used in production.

The maximum heat input to be used in production shall be used in the qualification testing. The qualified maximum interpass temperature shall be the lowest interpass temperature used for any pass during qualification testing. Both weld metal and HAZ shall be tested. The weld metal shall meet all the mechanical properties required by Sec 10.20.7.3.1 or those for demand critical welds of Sec 10.20.7.3.2, as applicable. The heat affected zone CVN toughness shall meet a minimum requirement of 27 J at 21 °C with specimens taken at both 1 and 5 mm from the fusion line.

S.6.5 Weld Tabs

Where practicable, weld tabs shall extend beyond the edge of the joint a minimum of one inch or the thickness of the part, whichever is greater. Extensions need not exceed 50 mm.

Where used, weld tabs shall be removed to within 3 mm of the base metal surface, except at *continuity plates* where removal to within 6 mm of the plate edge is acceptable, and the end of the weld finished. Removal shall be by air carbon arc cutting (CAC-A), grinding, chipping, or thermal cutting. The process shall be controlled to minimize errant gouging. The edges where weld tabs have been removed shall be finished to a surface roughness of 13 μm or better. Grinding to a flush condition is not required. The contour of the weld end shall provide a smooth transition, free of notches and sharp corners. At T-joints, a minimum radius in the corner need not be provided. The weld end shall be free of gouges and notches. Weld defects not greater than 2 mm deep shall be faired to a slope not greater than 1:5. Other weld defects shall be excavated and repaired by welding in accordance with an applicable WPS.

S.6.6 Bottom Flange Welding Sequence

When using weld access holes to facilitate CJP groove welds of beam bottom flanges to column flanges or continuity plates, the groove weld shall be sequenced as follows:

- (1) As far as is practicable, starts and stops shall not be placed directly under the beam web.
- (2) Each layer shall be completed across the full width of the flange before beginning the next layer.
- (3) For each layer, the weld starts and stops shall be on the opposite side of the beam web, as compared to the previous layer.

S.7 Additional Welding Provisions for Demand Critical Welds Only

S.7.1 Welding Processes

SMAW, GMAW (except short circuit transfer), FCAW and SAW may be used to fabricate and erect members governed by this specification. Other processes may be used, provided that one or more of the following criteria is met:

- (a) The process is part of the prequalified connection details, as listed in Appendix N,
- (b) The process was used to perform a connection qualification test in accordance with Appendix Q, or
- (c) The process is approved by the engineer of record.

S.7.2 Filler Metal Packaging

Electrodes shall be provided in packaging that limits the ability of the electrode to absorb moisture. Electrode from packaging that has been punctured or torn shall be dried in accordance with the manufacturer's recommendations, or shall not be used for *demand critical welds*. Modification or lubrication of the electrode after manufacture is prohibited, except that drying is permitted as recommended by the manufacturer.

S.7.3 Exposure Limitations on FCAW Electrodes

After removal from protective packaging, the permissible atmospheric exposure time of FCAW electrodes shall be limited as follows:

- (1) Exposure shall not exceed the electrode manufacturer's guidelines.
- (2) In the absence of manufacturer's recommendations, the total accumulated exposure time for FCAW electrodes shall not exceed 72 hours. When the electrodes are not in use, they may be stored in protective packaging or a cabinet. Storage time shall not be included in the accumulated exposure time. Electrodes that have been exposed to the atmosphere for periods exceeding the above time limits shall be dried in accordance with the electrode manufacturer's recommendations, or shall not be used for demand critical welds. The electrode manufacturer's recommendations shall include time, temperature, and number of drying cycles permitted.

S.7.4 Tack Welds

Tack welds attaching backing bars and weld tabs shall be placed where they will be incorporated into a final weld.

PART VI
Appendix T

**Weld Metal/Welding Procedure Specification Notch Toughness
Verification Test**

T.1 Scope

This Appendix provides a standard method for qualification testing of weld filler metals required to have specified notch toughness for service in joints designated as demand critical.

Testing of weld metal to be used in production shall be performed by filler metal manufacturer's production lot, as defined in AWS A5.01, Filler Metal Procurement Guidelines, as follows:

- (1) Class C3 for SMAW electrodes,
- (2) Class S2 for GMAW-S and SAW electrodes,
- (3) Class T4 for FCAW and GMAW-C, or
- (4) Class F2 for SAW fluxes.

Filler metals produced by manufacturers audited and approved by one or more of the following agencies shall be exempt from these production lot testing requirements, provided a minimum of 3 production lots of material, as defined above, are tested in accordance with the provisions of this appendix:

- (1) American Bureau of Shipping (ABS),
- (2) Lloyds Register of Shipping,
- (3) American Society of Mechanical Engineers (ASME),
- (4) ISO 9000,
- (5) US Department of Defense, or
- (6) A quality assurance program acceptable to the engineer of record.

Under this exemption from production lot testing, the filler metal manufacturer shall repeat the testing prescribed in this appendix at least every three years on a random production lot.

T.2 Test Conditions

Tests shall be conducted at the range of heat inputs for which the weld filler metal will be qualified under the welding procedure specification (WPS). It is recommended that tests be conducted at the low heat input level and high heat input level indicated in Table 6.T.1.

Table 6.T.1 WPS Toughness Verification Test Welding and Preheat Conditions

Cooling Rate	Heat Input	Preheat (°C)	Interpass (°C)
Low heat input test	31.2 kJ/mm	21 ± 14	93 ± 28
High heat input test	3.1 kJ/mm	149 ± 14	260 ± 28

Alternatively, the filler metal manufacturer or contractor may elect to test a wider or narrower range of heat inputs and interpass temperatures. The range of heat inputs and interpass temperatures tested shall be clearly stated on the test reports and user data sheets. Regardless of the method of selecting test heat input, the WPS, as used by the contractor, shall fall within the range of heat inputs and interpass temperatures tested.

T.3 Test Specimens

Two test plates, one for each heat input, shall be welded following Table 6.T.1. Five CVN specimens and one tensile specimen shall be prepared per plate. Each plate shall be steel, of any AISC-listed structural grade. The test plate shall be 19 mm thick with a 13 mm root opening and 45° included groove angle. The test plate and specimens shall be as shown in Figure 2A in AWS A5.20, or as in Figure 5 in AWS A5.29. Except for the root pass, a minimum of two passes per layer shall be used to fill the width.

All test specimens shall be taken from near the centerline of the weld at the mid-thickness location, in order to minimize dilution effects. CVN and tensile specimens shall be prepared in accordance with AWS B4.0, Standard Methods for Mechanical Testing of Welds. The test assembly shall be restrained during welding, or preset at approximately 5° to prevent warpage in excess of 5°. A welded test assembly that has warped more than 5° shall be discarded. Welded test assemblies shall not be straightened.

The test assembly shall be tack welded and heated to the specified preheat temperature, measured by temperature indicating crayons or surface temperature thermometers one inch from the center of the groove at the location shown in the figures cited above. Welding shall continue until the assembly has reached the interpass temperature prescribed in Table 6.T.1. The interpass temperature shall be maintained for the remainder of the weld. Should it be necessary to interrupt welding, the assembly shall be allowed to cool in air. The assembly shall then be heated to the prescribed interpass temperature before welding is resumed.

No thermal treatment of weldment or test specimens is permitted, except that machined tensile test specimens may be aged at 93 °C to 104 °C for up to 48 hours, then cooled to room temperature before testing.

T.4 Acceptance Criteria

The lowest and highest Charpy V-Notch (CVN) toughness values obtained from the five specimens from a single test plate shall be disregarded. Two of the remaining three values shall equal, or exceed, the specified toughness of 54 J energy level at the testing temperature. One of the three may be lower, but not lower than 41 J, and the average of the three shall not be less than the required 54 J energy level. All test samples shall meet the notch toughness requirements for the electrodes as provided in Section 10.20.7.3.2.

For filler metals classified as E70, materials shall provide a minimum yield stress of 400 MPa, a minimum tensile strength of 480 MPa, and a minimum elongation of 22 percent. For filler metals classified as E80, materials shall provide a minimum yield stress of 470 MPa, a minimum tensile strength of 550 MPa, and a minimum elongation of 19 percent.

PART VI**Appendix U****Volume Fraction of Reinforcement and Types of Steel Wire Meshes
Used in Ferrocement****U.1 Calculation of Volume Fraction of Reinforcement**

The volume fraction of reinforcement in a ferrocement section can be readily calculated if the density of the mesh material and the weight of mesh per unit area are known.

For ferrocement section reinforced with expanded metal mesh, the volume fraction of mesh reinforcement may be calculated from the following relationship.

$$V_f = \frac{\text{Volume of mesh}}{\text{Volume of ferrocement section}} = \frac{\omega_m N}{\gamma_m h} \times 100 \text{ per cent}$$

For ferrocement reinforced with square or rectangular mesh, the volume fraction of mesh reinforcement may be calculated from the following relationship:

$$V_f = \frac{N\pi d_b^2}{4h} \left(\frac{1}{D_t} + \frac{1}{D_l} \right) \times 100 \text{ per cent}$$

Where,

N	=	number of layers of mesh reinforcement
d_b	=	diameter of mesh wire
h	=	thickness of ferrocement
D_t	=	centre to centre spacing of wires aligned transversely in reinforcing mesh, mm
D_l	=	centre to centre spacing of wires aligned longitudinally in reinforcing mesh, mm
ω_m	=	weight of mesh per unit area, N/mm ²
γ_m	=	unit weight of steel, N/mm ²

U.2 COMMON TYPES AND SIZES OF STEEL MESHES USED IN FERROCEMENT

Type	Shape	Fabrication	Mesh Size*	Wire Gauge*	Wire Spacing (mm)	Wire Diameter or Sheet Thickness (mm)
			$\frac{3}{4} \times \frac{3}{4}$	No. 16	19.0	1.60
	Square	Woven or Welded	2 x 2	No. 19	13.0	1.00
			3 x 3	No. 22	8.5	0.72
		4 x 4	No. 23	6.4	0.64	
Wire Mesh		Welded	1 x 1	No. 14	25.0	2.00
	Rectangular	Welded	2 x 1	No. 14	50 x 25	2.00
			1	No. 18	25.0	1.20
	Hexagonal	Twisted	1	No. 20	25.0	0.88
			$\frac{1}{2}$	No. 22	13.0	0.72
Expanded Metal Mesh	Diamond	Slit and Drawn		Gauge No. 18		1.00
				Gauge No. 20		0.76
				18 N/m ²		0.58

*American wire gauge

PART VII
Chapter 1
Constructional Responsibilities and Practices

1.1 Introduction

This part of the Code provides the minimum requirements for safe constructional operations, constructional planning, management and practices in buildings; as well as for storage, stacking and handling of materials and resources used in buildings. It describes precautionary measures to be adopted to ensure the safety of public, environment and infrastructure, property, workmen, materials, services, plant and equipment. It also covers guidelines relating to maintenance management, repairs, retrofitting and strengthening of buildings.

1.2 Scope

The regulations stated in this part cover the constructional responsibilities and practices in building sites; safe storing, stacking and handling of materials, equipment and other resources; and safety of personnel during construction operations. The provisions of this part shall apply to all construction operations viz. erection, alteration, repair, removal or demolition of buildings and structures.

Nothing herein contained shall be construed to nullify any rules, regulations, safety standards or those contained in the various act of the Government of Bangladesh, statutes governing the protection of the public or workers from any hazard involved in manufacturing, mining and other processes and operations which generate toxic gases, dust or other elements dangerous to the respiratory system, eye sight or health.

1.3 Terminology

This section provides an alphabetical list of the terms used in and applicable to this part of the Code. In case of any conflict or contradiction between a definition given in this section and that in any other part, without prejudice to provisions arising from laws, statutes and recourses provided under such laws, statutes and covenants of GOB and trade bodies. The meaning provided in this part shall govern for interpretation of the provisions of this part. References shall be made to other part of this Code for terms not defined in this section.

AUTHORITY	Same as defined in Chapter 2 Part 1.
AUTHORIZED OFFICER	Same as defined in Chapter 2 Part 1.
BLAST AREA	The area in which danger may arise during or prior to demolition including the potential area affected by preparation, handling and use of explosives.

BLASTING	The operation of disintegrating rock, structure etc. by firing an explosive charge.
CARTRIDGE	A wrapped or otherwise protected cylinder of defined size of a homogeneous explosive material.
CONSULTANT	The “Consultant” is the organisation/person whose proposal to perform the Services like design, supervision or other technical and/or management services has been accepted by the Owner/ Client and has a Contract Agreement to execute the service.
CONSTRUCTION EQUIPMENT	All equipment, machineries, tools and temporary retaining structures and working platforms, such as derricks, concrete pump, staging, scaffolds, runways, ladders and all material handling equipment including safety devices.
CONTRACTORS	Contractor means the natural person, private or government enterprise, or a combination of the above, whose Tender to carry out the Works has been accepted by the Employer and is named as such in the Contract Agreement, and includes the legal successors or permitted assigns of the Contractor.
DETONATOR	An instantaneous or delay initiator for explosive materials and containing a charge of high explosive fired by means of a flame, spark or electric current.
EMPLOYER	The Employer is the party named who employs the Consultant and/or Contractor to carry out the Works.
EXPLOSIVE	Any substance, whether or not contained in a device, used or manufactured with a view to producing an effect by explosion.
FLOOR HOLE	An opening in any floor, platform, pavement, or yard, measuring less than 300 mm but more than 25 mm in its least dimension, through which materials but not persons may fall; e.g. a belt hole, pipe opening or slot opening.
FLOOR OPENING	An opening in any floor, platform, pavement or yard bigger than a floor hole measuring 300 mm or more in its least dimension, through which a person may fall; e.g. hatchway, stair or ladder opening, hopper mouth pit or large manhole.
GUARD RAILING	A barrier erected along exposed edges of an open side, floor opening, wall opening, ramp, platform or catwalk or balcony, etc. to prevent the fall of persons.

HOISTS	A platform, bucket or similar enclosure made of steel frames, struts and timber planks used for the lifting or lowering of construction material and workmen, the hoists being operated from a point outside the conveyance.
MAGAZINE	Any building or structure used for the storage of explosives with approval of the Authority.
PILE RIG	The complete pile driving equipment comprising piling frame, leader, hammer, extractor, winch and power unit. Complete pile driving rig may be mounted on rafts or pontoon or rails. Pile rig may also be a mobile unit mounted on trailers or trucks, or a special full revolving rig for raking piles.
PLATFORM	A working space for persons, elevated above the surrounding floor or ground, e.g. balcony or platform for the operation of machinery and equipment.
PRIMER	A cartridge cord or container of explosive into which a detonator or detonating cord is inserted or attached and is designed to initiate a larger charge.
PROFESSIONALS	“Professionals” means technical personnel and support staff provided by the Consultant or by any Sub-Consultant and assigned for supervising the execution and completion of the Works and administering the Contract.
SALVAGE	An act of saving and utilization of reusable scrap materials conforming to the requirements of this Code.
SCAFFOLD	A temporary erection of timber or metal work used to support or to allow the hoisting and lowering of workmen, tools and materials during construction, alteration or demolition of a building.
SHOTFIRER	The person in immediate control of the use of explosives.
TOE BOARD	A vertical barrier erected along exposed edge of a floor opening, wall opening, platform, catwalk or ramp at floor level to prevent fall of materials or persons.
WALL HOLE	An opening in any wall or partition having a height of more than 25 mm to less than 750 mm and having no restriction in width.
WALL OPENING	An opening in any wall or partition having a height of at least 750 mm and a width of at least 450 mm.
WORKMEN/ LABOURERS	“Workmen” means any natural person who has a Contract with the Contractor to carry out a part of the work in the Contract, which includes work on the site.

1.4 Planning

Construction planning aspects aim to identify and develop various stages of project execution on site which shall be consistent with the management considerations. Planning aspects evolve out of the objectives of project and requirements of the final completed constructed facility. These objectives can relate to the final constraints, cost considerations, quality standards, safety standards as well as both environmental and health considerations. Construction practices shall, then have to satisfy these objectives during construction phase of the project. Having established objectives of the construction phase, planning determines processes, resources (including materials, equipment, human and environmental) and monitoring system to ensure that the practices are appropriately aligned. Adequate knowledge about pre-construction phase evolution of project, especially related to customer's requirements, is an essential prerequisite for construction planning.

1.4.1 Responsibilities

In a construction or demolition work, the terms of contract between the owner and the contractor, and between a consultant and the owner, shall be clearly defined and put in writing. These, however, will not absolve the owner from any of his responsibilities under the various provisions of this Code, and other applicable regulations and bye-laws.

The terms of contract between the owner and the contractor will determine the responsibilities and liabilities of either party in the concerned matters, within the provisions of the relevant acts and codes (e.g. the Employer's Liability Act 1938, the Factories Act 1965, the Fatal Accident Act 1955 and Workmen's Compensation Act 1923).

The owner, or the professional appointed by him to supervise the work, shall ensure the quality of materials used, soundness of the work and observance of all precautionary measures.

1.4.2 First Aid Attendant

Depending on the scope and nature of the work, at least one person trained in first aid for every 100 workers shall be available at work site to render and direct first aid to casualties. The first aid attendant shall have a refresher course every five years and certificates renewed.

A telephone shall be made available to first aid assistant with emergency telephone numbers prominently displayed. Record/reports of all accidents and actions taken thereon shall be kept by the first aid attendant and forwarded to appropriate authorities when asked.

1.4.3 Temporary Construction

Plan, layout, design and specification of all temporary constructions, e.g. workers' shed, toilet, site store, site office, runway, trestle, foot bridge, guard shed etc., which are likely to interfere with right-of-way or utility services provided by various agencies, shall be submitted to the respective authorities for approval before commencement of any construction operation.

Temporary structures shall be constructed from inflammable materials, but they shall be so located as not to cause any fire hazard to adjoining structures or works and neighboring properties.

1.4.4 Preconstruction Phase

Besides the design aspects, preconstruction phase should also address all the issues related to the implementation of the design at the site through suitable construction strategy. During the design stage, the site conditions should be fully understood with anticipated difficulties and avoid the risk of subsequent delays and changes after the construction has started.

The selection of construction methods, building systems and materials, components, manpower and equipment and techniques are best done in the preconstruction phase. Such selection is influenced by the local conditions like terrain, climate, vulnerability for disasters, etc.

Construction in busy localities of cities needs special considerations and meticulous planning due to restricted space, adjoining structures, underground utilities, traffic restrictions, noise and other environmental pollution and other specific site constraints,

The constructability aspects of the proposed construction methods needs to be carefully evaluated at the planning stage to ensure ease of construction besides optimizing the construction schedule and achieving quality, reliability and maintainability of the constructed facilities.

Constructional practices in hilly regions needs to take into considerations the problem of landslides, slope stability, drainage, etc, besides ensuring no adverse impact on the fragile environmental conditions.

Durability of constructions in corrosive atmospheric conditions like coastal regions and aggressive ground situations with high chlorides and sulphates should also be taken care of with appropriate constructional practices.

Constructional practices in disaster prone areas need specific planning. The type of construction, use of materials, construction techniques require special considerations in such areas.

Adverse weather conditions have strong bearing on construction phase. Situations wherein constructions are to be carried out in adverse weather conditions, such as heavy and continuous rain fall, extreme hot or cold weather, dust storms, etc, the practices have to address the relevant aspects. Accordingly, suitable design and field operations should be adapted or redefined in anticipation of these aspects. Some of these aspects are.

- (a) Site layout which enables accessibility in adverse weather.
- (b) Adequate protected storage for weather sensitive materials/equipment.
- (c) Protections to personnel from extreme hot/control conditions.
- (d) Scheduling to allow maximization of outdoor activities during fair weather conditions.
- (e) Special design and construction provisions for activities in extreme temperature conditions like hot or cold weather concreting, staple of false work in extreme wind conditions (gusts).
- (f) Adequate lighting for shorter days in winter/night work.
- (g) Design for early enclosure; and
- (h) Adjacent historically important structure shall be given highest care against any damage during construction process.

All sanitary facilities shall be kept in a hygienic condition. Temporary toilets shall be enclosed, screened and weather proofed and shall be installed and maintained in accordance with the relevant part of the Code.

1.4.5 Construction Phase

1.4.5.1 Organizational structure

The site management should be carried out through suitable site organization structure with roles and responsibilities assigned to the construction personnel for various construction related functions. Safety management is one of the important components of site management.

1.4.5.2 Site layout

The layout of the construction site shall be carefully planned keeping in view the various requirements to construction activities and the specific constraints in terms of its size, shape, topography, traffic and other restrictions, in public interest. The site layout shall take into considerations the following factors.

- (a) Easy access and exit, with proper parking of vehicle and equipment during construction.
- (b) Properly located material stores for easy handling and storage.

- (c) Adequate stack areas for bulk construction materials.
- (d) Optimum location of plants and equipment (batching plants etc.).
- (e) Layout of temporary services (water, power, power suppression unit, hoists, cranes, elevators etc.).
- (f) Adequate yard lighting and lighting for night shifts.
- (g) Temporary buildings; site office and shelter for workforce with use of non-combustible materials as far as possible including emergency medical aids.
- (h) Roads for vehicular movement with effective drainage plan.
- (i) Construction safety with emergency access and evacuations and security measures.
- (j) Fabrication yards for reinforcement assembly, concrete casting and shattering materials; and
- (k) Fencing, barricades and signage.

1.4.5.3 Access for firefighting equipment vehicles

Access for firefighting equipment shall be provided to the construction site at the start of construction and maintained until all construction work is completed.

Free access from the street to fire hydrants/static water tanks, where available, shall be provided and maintained at all times.

No materials for construction shall be placed within 3 m of hydrants/static water tanks.

During building operations, free access to permanent, temporary or portable first-aid firefighting equipment shall be maintained at all times.

In all buildings over two stories high, at least one stairway shall be provided in usable condition at all times. This stairway shall be extended upward as each floor is completed. There shall be a handrail on the staircase.

1.4.5.4 Construction strategy and construction sequence

Construction strategy and construction methods are to be evolved at the planning and design stage specific to the conditions and constraints of the project site and implemented by the site management personnel to ensure ease of construction and smooth flow of construction activities.

Sites of high water table conditions with aggressive chemical contents of subsoil needs special design considerations. Buildings with basement in sites of high water table should be planned with dewatering scheme with appropriate construction sequence, Duration of

dewatering shall continue till sufficient dead loads are achieved to stabilize the buoyancy loads with adequate factor of safety. The construction sequence should be planned taking into consideration the following aspects.

- (a) Availability of resources (men, material and equipment).
- (b) Construction methods employed including prefabrication.
- (c) Planned construction time.
- (d) Design requirements and load transfer mechanism.
- (e) Stability of ground like in hilly terrain.
- (f) Ensuring slope stability with retaining structure before the main construction.
- (g) Installation and movement of heavy equipment like cranes and piling equipment.
- (h) Effect of weather.
- (i) Minimum time to be spent below ground level working; and
- (j) Protection against ground water seepage.

1.5 Construction Control

1.5.1 General

All construction including extension, alteration and demolition shall require a permit from the Authority. Permits shall also be obtained from relevant organizations for service connections and other facilities. The construction work shall conform to the plan approved by the Authority.

The owner shall make arrangements for obtaining the required approvals.

All new work or alteration shall be planned, designed, supervised and executed by competent professionals of relevant discipline.

1.5.2 Professional Services and Responsibilities

The responsibility of professionals with regard to planning designing and supervision of building construction work, etc. and that of the owner shall be in accordance with the relevant part of the Code and professional practice. Employment of trained workers shall be encouraged for building construction activity.

1.5.3 Construction of all Elements

Construction of all elements of a building shall be in accordance with good practice. It shall also be ensured that the elements of structure satisfy the appropriate fire resistance requirements as specified in Part 4 'Fire Protection', and quality of building materials/components used shall be in accordance with Part 5 'Building Materials'.

1.5.4 Construction Using Bamboo

Bamboo being a versatile resource characterized by high strength, low mass and ease of working with simple tools, it is desirable to increasingly make appropriate use of this material. Design of structures using bamboo shall be done in accordance with Chapter 4, Part 6.

For construction using bamboo, some of the important constructional provisions given below shall be followed.

Bamboo can be cut and split easily with very simple hand tools. Immature bamboos are soft, pliable and can be molded to desired shape. It takes polish and paint well.

While it is possible to work with bamboo simply using a machete, a few basic tools, such as, machete, hack saw, axe, hatchet, sharpening tools, adze, chisel (20 mm), chill, wood rasps, steel rod, and pliers, will greatly increase the effectiveness of the construction process.

For providing safety to the structure against fire, bamboo may be given fire retardant treatment using following chemicals; a few drops of concentrated HCL shall be added to the solution to dissolve the precipitated salts:

Ammonium phosphate	3 parts	Zinc chloride	5 parts
Boric acid	3 parts	Sodium dichromate	3 parts
Copper sulphate	1 part	Water	100 parts

Bamboo indirect contact with ground, bamboo on rock or preformed concrete footing, bamboo incorporated into concrete or bamboo piles may form the foundation structure.

The floor of bamboo may be at ground level with covering of bamboo matting, etc. In elevated floors, bamboo members become an integral part of structural framework of building. The floor will comprise structural bamboo elements and bamboo decking.

The jointing techniques in construction using bamboo shall be in accordance with Chapter 4, Part 6.

1.5.5 Low Income Housing

For low income housing, appropriate planning and selection of building materials and techniques of construction have to be judiciously done and applied in practice. Requirements of low income housing specified in Part 3 shall be followed. However, all requirements regarding structural safety, health safety and fire safety shall be in accordance with this Code.

1.5.6 Site Preparation

While preparing the site for construction, bush and other wood, debris, etc. shall be removed and promptly disposed of so as to minimize the attendant hazards. Temporary buildings for construction offices and storage shall be so located as to cause the minimum fire hazards and shall be constructed from noncombustible materials as far as possible.

1.5.7 Use of New /Alternative Construction Techniques

The provisions of this part are not intended to prevent use of any construction techniques including any alternative materials, nonspecifically prescribed by the Code, provided any such alternative has been approved. The Authority may approve any such alternative such as ferrocement construction, row-lock (rat trap) bond in masonry, stretcher bond in filler slab and filler slab provided; that the proposed alternative is satisfactory and conforms to the provisions of relevant parts regarding material, design and construction of this Code. The material or method or work offered as alternative is, for the purpose intended, at least equivalent to that prescribed in the Code in quality, strength, compatibility, effectiveness, fire and water resistance, durability and safety.

1.5.8 Permits

The owner of a building shall obtain permission from the Authority for the work to be undertaken in accordance with the provisions of the relevant part of this Code.

Special permits shall be obtained from relevant authorities before commencement of a particular construction work for the following items and for any other item as decided by the Building Official.

- (a) Storing materials on roads and sidewalks.
- (b) Using water, electricity, gas, sewerage or other public utilities.
- (c) Digging roads or interfering with the drainage system.
- (d) Storing and handling of explosives; and
- (e) Affecting any structure having historical association and antiquity.

1.5.9 Tests and Inspections

The Authority shall notify both the owner and the contractor of any unsafe, unlawful or unethical situation discovered during inspection and direct them to take necessary remedial measures to remove the hazard or rectify the violation.

Where the strength or adequacy of any scaffold or other device or construction equipment is in doubt, or where any complaint is lodged, the Authority shall inspect such equipment and shall prohibit its use until tested safe or until all danger is removed.

1.6 Construction Management

Employer and Management shall be responsible for optimizing Construction Planning, resource utilization, and scope, time, quality, health, safety and environment and cost for implementation, monitoring and control for their effectiveness. This may be preferably in line with proven National/International documentation system covering all aspects of monitoring and controls. Various parameters to be managed during construction are as below.

1.6.1 Time Management

The project shall be completed in the defined time schedule to get its fruitful benefits. The system planned shall cover total schedule of completion with one or more construction agencies, number of vendors, identification of total resources, timely availability of all inputs, including critical ones, its processing during construction of a project. The system shall include a periodic review of a project with all parameters as well as catch up plans in case of delay identified for controls and reporting from time to time. The system planned shall preferably be computer friendly and simple to follow for implementation, monitoring and controls and for reporting from time-to-time.

1.6.2 Quality Management

Quality of a project shall be planned for all activities from inception to completion. It is desirable that the system planned gives adequate assurance and controls that it shall meet project quality objectives. The system shall cover review of existing requirements, subcontracting, materials, processes and controls during process, auditing, training of personnel, final inspection and acceptance. All activities shall be planned and controlled. Quality systems approach may be referred for planning, suitable to a particular project for implementation.

1.6.3 Health, Safety and Environment

Each project affects the safety and health of the workmen and surroundings during construction. Various activities having impact on health, safety and environment need to be identified with their likely effect and proposed preventive corrective actions, together with the concerned statutory obligations. The system planned for health, safety and environment shall address and cover the above including use of personnel protective equipment by all concerned and reporting on their monitoring and controls during project implementation.

1.6.4 Cost Management

To keep the project under viable proposition, it is desired that cost of the project during construction are monitored and controlled through a documentation system. The various parameters which may affect the basic cost, escalations, cost due to variation in scope and quantities, etc. need to be monitored at a defined frequency. The system planned shall be in line with a proven cost control method or similar in nature and cost incurred vis-a-vis cost sanctioned and cost anticipated to be reported and controlled from time to time.

1.7 Protection of Public and Workers

1.7.1 General

Erection, alteration, renovation, remodeling, repairing, removal or demolition of a building or structure shall be conducted in a safe manner. Suitable protection for the general public and workers employed thereon shall be provided according to the various provisions of this Code.

All existing and adjoining public and private property shall be protected from any damage due to construction operations. Whenever requested, site plans, construction details, and specification shall be submitted for review by the concerned agency.

All equipment and safeguard required for the construction work such as temporary stair, ladder, ramp, scaffold, hoist, runway, barricade, chute, lift etc. shall be substantially constructed and erected so as not to create any unsafe situation for the workmen using them or the workmen and general public passing under, on or near them.

Public walkway shall not be occupied to carry out work under a building permit unless the pedestrians are protected as specified in this section. Any material or structure temporarily occupying public property, including fences and walkways, shall be adequately lighted at night.

1.7.2 Adjoining Property

The owner of the building shall preserve all adjoining structures and walls from damage. He shall support the adjoining building or structure by proper foundations to comply with the Code.

Necessary permissions to preserve and protect the adjoining plot, building or structure shall be obtained by the owner of the building to be constructed. Adjoining property shall be completely protected from any damage due to the building operation when the owner of the adjoining property permits free access to the adjoining site and building.

If required, the owner of the adjoining plot, building or structure shall be granted necessary permission to enter the construction site to make his own property safe.

No part of any structure, except signs, shall project beyond the property line of the site. Sidewalk sheds, underpinning and other temporary protective guards and devices may project beyond the property lines if approved by the Authority. Where necessary, the permission of the adjoining property owner shall also be obtained.

Where a construction or demolition is undertaken at a level higher than the adjacent structure, the roof, roof outlets, skylights and other roof structures of adjoining buildings shall be protected against damage. This shall be ensured by the owner of the construction site at his own expense.

Where the grade of the adjoining plot is lower than the site level, a retaining wall shall be erected, if necessary, at the owner's expense and on his site. Design and construction of retaining wall shall conform to the structural requirements for such walls, and may have a railing or fence at the top to provide a total height of not less than 1 m above the finished grade of the higher plot.

If the owner, lessee or tenant of the adjoining building refuses permission to have the roofs and skylights of the adjoining building protected, the responsibility and expense for the said protection shall transfer to the person refusing such permission.

During any demolition or excavation work, the structure or the wall shall be maintained structurally safe by adequate temporary props and lateral supports.

1.7.3 Protective Fences and Railings

Pedestrian traffic on the adjacent road or footpath, or the walkway constructed shall be protected by a railing or fence. Protective railing or fence shall also be placed adjacent to excavations. Railings shall be at least 1m in height and when adjacent to excavations, shall be provided with a mid-rail.

All construction work within 1.5 m from the road shall be enclosed with a fence not less than 2.4 m high from the grade. If the work is more than 1.5 m away from the road, a fence or other barriers shall be erected at least on the side of the site nearest to the footpath/road. The fence shall extend over the entire length of the side. Openings in fences may have doors which normally shall be kept closed.

All fences shall be of adequate strength to resist wind pressure and other load as specified in relevant part of the Code. All fences shall be well braced. The side of any fence/handrail adjacent to a road or sidewalk shall be kept smooth. Fences, barriers, or temporary structures of any kind located on public roads shall not obstruct vision at the intersection of streets.

1.7.4 Canopies, Overhangs and Platforms

Protective canopy shall have a clear height of 2.4 m over the walkway. Walkways under the canopy shall be not less than 1.2 m wide in the clear. However, the Building Regulatory Authority may instruct differently regarding the clear width in congested areas.

Every canopy shall have a fence built along its entire length on the construction side. If materials are stored or work is done on the roof of the canopy, edges of the canopy roof shall have a tight curb board not less than 200 mm high and a railing not less than 1 m high. The entire structure shall be designed to carry the loads to be imposed.

The posts or other supporting members of any temporary structure on the road side shall be designed for the load due to vibration generated by the street traffic. The framework supporting the covering shall be well braced and designed to support at least 7 kPa. However the top deck shall be designed to carry load not less than 10 kPa.

The roof covering shall be of a width sufficient to cover the entire walkway or side walk and shall be made watertight. Covered walkways shall be provided with adequate lights at all times.

Cantilevered platforms or other substitute protection in lieu of sidewalk sheds shall not be used unless approved by the authority and deemed adequate to insure public safety.

Materials shall not be stored on overhangs unless these are designed for the load. Such storage shall in no case exceed a day's supply. All materials shall be piled in an orderly manner and height to permit removal without endangering the stability of the pile and canopy.

1.7.5 Protection of Utilities

Protective frame and boarding shall be built around and over every street lamp, utility box, fire and police alarm box, fire hydrant, catch basin and manhole that may be damaged by any construction work. The protection shall be maintained while such work is being done; and shall not obstruct the normal functioning of the device.

Building material, fence, shed etc. shall not obstruct free access to any fire hydrant, lamppost, manhole, fire alarm box, or catch basin, or interfere with the drainage of the site. Protective covers shall be provided to such utility fixtures during the progress of the work without obscuring their identity.

Precaution shall be taken during construction to prevent concrete, mortar washing or any other material from entering and blocking a sewer.

1.7.6 Use of Road and Footpath

Road and footpath spaces may be used only temporarily during construction subject to the following conditions.

- (a) Permissions shall be obtained from relevant authorities for all such uses.
- (b) The allocated space or any portion thereof shall be more than 1.5 m away from a railway track.
- (c) A walkway shall be constructed in the outer portion of the road space permitted to be occupied in conformity with Sec 1.4.2 and 1.4.3.
- (d) One (1) metre clear passage shall be maintained along the building site.
- (e) Person(s) who has been issued a permit to use road and footpath spaces shall furnish a bond with the relevant authority of such type and amount as may be deemed advisable by the authority as protection from all liabilities.

- (f) The permittee shall repair any damages done to the adjacent road due to its use for construction work at his own expense; the bond money shall stand forfeited if the permittee fails to comply with this requirement; and
- (g) It shall be used in a manner that will not deface it or create a nuisance. The owner, upon the completion of the building, shall immediately remove all temporary walkways, debris and all other obstruction and leave such public property in as good a condition as it was before such work commenced.

1.7.7 Protective Devices

No structure, fire protection or sanitary safeguard or device shall be removed or made inoperative unless instructed by the Authority. Pedestrian protection required by all relevant regulations shall be maintained in place and kept in good order as long as pedestrians may be endangered. Every protection, fence, canopy and other protective devices shall be removed within 7 days after such protection is no longer required.

1.7.8 Notices and Signs

Every walkway adjacent to a construction, demolition or excavation site shall be kept well-lighted at night. The outer edge of the occupied space of the street or footpath shall have red lights placed thereon which shall flash continuously day and night.

Boards with caution signs, along with safety regulations and emergency instructions painted in bright colour, preferably red, shall be erected near the entry and in prominent places of the site. It shall describe appropriate measures for the elimination or control of the danger and the conduct and course of action to be taken. Red caution marks shall also be placed on the building, equipment and utility connections.

1.7.9 Watchman and Auditory Signal

A watchman shall be employed to warn the general public when intermittent hazardous operations are conducted. Audible signal shall be used in case of extreme danger. It shall be such that any person in the reception area can recognize and react to the signal as intended. An auditory emergency evacuation signal shall take precedence concerning recognition over all auditory signals.

1.7.10 Safe Load

No structure, temporary support, scaffolding, sidewalk, footpath and drain covers, shed, other devices and construction equipment shall be loaded in excess of its safe working capacity.

Whenever the structural quality or strength of scaffolding plank or other construction equipment is in doubt, these shall be replaced or be subject to a strength test to two and half times the superimposed live load; the member may be used if it sustains the test load without failure. Requirements of Sec 3.8 shall be observed regarding design loads in scaffolds.

1.8 Environmental Protection

The following provisions shall be met during construction for environmental protection. The construction and operation of the work/project shall comply with relevant national environmental legislation including environmental quality standards. The basic responsibility of the contractor/owner towards the environment shall be:

- (a) To take all reasonable steps to protect the environment and avoid damage and nuisance arising because of his/her operations.
- (b) To comply with all status and regulations concerning the execution of works.
- (c) To familiarize himself with all legislation relating to environmental protection that is relevant to his activities. Reference to national environmental quality guidelines shall be made.
- (d) Responsible for the costs of cleaning up any environmental pollution resulting from his/her activities during construction.

1.8.1 Protection of Existing Drainage Systems and Utilities

During construction work all excavation and/or filling work shall be taken as to ensure safety to the existing underground utility lines and drainage system. The Contractor/Owner shall obtain written permission from the respective authorities before excavation or filling in such areas.

1.8.2 Protection of Soil, Aquifers, and Water Channels against Pollution

Construction activities are likely to generate waste in various forms. This shall be dealt with adequately to avoid pollution. The following measures shall be taken during construction of work.

- (a) The Contractor/Owner shall, all times, maintain all sites under his control in a clean and tidy condition and shall provide appropriate and adequate facilities for the temporary storage of all wastes before disposal.
- (b) The Contractor/Owner shall be responsible for the safe transportation and disposal of all wastes generated because of his/her activities in such a manner as to not cause environmental pollution or hazards to health in any form. In the event of any third party being employed to dispose of wastes, the Contractor/Owner shall be considered to have discharged his/her responsibilities from the time the wastes leave sites under his/her control, providing that he/she has exercised due diligence in ascertaining that the proposed transport and disposal arrangements are such as to not cause pollution or health hazards.

- (c) The Contractor/Owner shall not allow waste oils or other petroleum derived wastes to be used as dust suppressants and that all reasonable precautions shall be taken to prevent accidental spillage of petroleum products, their contact with soil or discharge into water courses.
- (d) The Contractor/Owner shall be responsible for the provision of adequate sanitary facilities for the construction workforce (including those employed under subcontracts) at all construction and camp sites. The Contractor/Owner shall not knowingly allow the discharge of any untreated sanitary wastes to ground water or surface water. Before mobilization of the construction workforce, the Contractor/Owner shall provide details of sanitary arrangements. The detail shall include maintenance and operation plans and generally be sufficient to assess whether the proposed facilities are adequate.
- (e) Where abstraction from a borehole by the Contractor/Owner results in adverse effects on groundwater, which at the time of commencement of the contract was being used by local people, the Contractor/Owner shall arrange supplies of equivalent quality and quantity of water to that previously available.

1.8.3 Protection of Air Quality from Obnoxious Emissions

To cover the unlikely event that dust blow becomes a nuisance, to the following effect shall be taken.

The Contractor/Owner shall take all reasonable measures to minimize dust-blow arising from any sites under his/her control by regular watering of any stockpiles, bare soil, and haul roads. Unsurpassed traffic areas and any sources of fugitive dust, when conditions require dust suppression.

1.8.4 Protection from Sound Pollution

The management shall be responsible for confining all construction and transportation activities in Residential and mixed Residential Areas strictly to normal business hours, so as not to cause emission of such sound and noise which is considered detrimental to human health. Such noisy activities shall not be carried out from 1800 hours in the evening to 0600 hours in the morning and on non-working days and holidays.

Noise nuisance shall be minimized through adequate machine maintenance and good site practices. However, a degree of unavoidable noise nuisance from construction is expected. Control vibration from piling operations is not possible without incurring an unreasonable financial cost.

The following noise control measures shall be taken during construction work.

- (a) All vehicles and plant operated by the contractor or (including subcontractors) shall be maintained according to the original manufacturer's specifications and manuals, with particular regard to the control of noise emissions. The Consultant/Authority shall have the right to require the Contractor to replace or rectify any vehicle or plant that he thinks emits excessive noise, within 48 hours of notice in writing.
- (b) The contractor shall make every reasonable effort to reduce noise nuisance caused by construction activities, including suing of crusher and ancillary plant in locations where the distance between them and residential areas is such that it results in attenuation of noise at existing residential areas.

1.8.5 Site Reinstatement

The construction sites shall be reinstated to an acceptable level to the following effect shall be included.

Upon completion of construction the Contractor/Owner shall remove equipment, surplus material, rubbish and temporary works of every kind, and the site in clean condition to the satisfaction of the appropriate Authority.

PART VII
Chapter 2
Storage, Stacking and Handling Practices

2.1 General Practices

2.1.1 General Requirements and Restrictions on Storage and Handling

Materials required in construction operations shall be stored, and handled in a manner to prevent deterioration and damage to the materials, ensure safety of workmen in handling operations and non-interference with public life including safety of public, prevention of damage to public property and natural environment.

Materials shall be stored and placed so as not to endanger the public, the workers or the adjoining property. Materials shall be stacked on well-drained, flat and unyielding surface. Material stacks shall not impose any undue stresses on walls or other structures.

Materials shall be separated according to kind, size and length and placed in neat, orderly piles. High piles shall be staggered back at suitable intervals in height. Piles of materials shall be arranged so as to allow a minimum 800 mm wide passageway in between for inspection and removal. All passageways shall be kept clear of dry vegetation, greasy substance and debris.

For any site, there should be proper planning of the layout for stacking and storage of different materials, components and equipment with proper access and proper maneuverability of the vehicles carrying the material. While planning the layout, the requirements of various materials, components and equipment at different stages of construction shall be considered.

Stairways, passageways and gangways shall not become obstructed by storage of building materials, tools or accumulated rubbish.

Materials stored at site, depending upon the individual characteristics, shall be protected from atmospheric actions, such as rain, sun, winds and moisture, to avoid deterioration.

Special and specified care should be taken for inflammable and destructive chemicals and explosive during storage.

2.1.2 Manual Handling

When heavy materials have to be handled manually each workman shall be instructed by his foreman or supervisor for the proper method of handling such materials. Each workman shall be provided with suitable equipment for his personal safety as necessary. Supervisors shall also take care to assign enough men to each such job depending on the weight and the distance involved.

2.1.3 Protection against Fire

Timber, Bamboo, coal, paints and similar combustible materials shall be kept separated from each other. A minimum of two dry chemical powder (DCP) type fire extinguishers shall be provided at both open and covered locations where combustible and flammable materials are stored.

Flammable liquids like petrol, thinner etc., shall be stored in conformity with relevant regulations.

Explosives like detonators, gun powder etc. shall be stored in conformity with the fire protection provisions set forth in this Code so as to ensure desire safety during storage. Stacks shall not be piled so high as to make them unstable under fire fighting conditions and in general they shall not be more than 4.5 m in height.

Materials which are likely to be affected by subsidence of soil like precast beams, slabs and timber of sizes shall be stored by adopting suitable measures to ensure unyielding supports.

Materials liable to be affected by floods, tides, etc. shall be suitably stored to prevent their being washed away or damaged due to floods, tides, etc.

2.1.4 Housekeeping

Stairways, walkways, scaffolds, gangways and access ways shall be kept free of building material, tools, accumulated rubbish and obstructions.

Materials or equipment stored on the street, footpath and other public places with permission from the proper Authority, and conforming to Sec 1.5.3, shall not interfere with vehicular traffic or pedestrians on the highway or street. The piles shall be arranged to leave a safe walkway unobstructed for its full length, and adequately lighted at night and at all other necessary times.

Material and equipment shall not be located within 7.5 m of a street intersection. These shall neither be so placed as to obstruct normal observation of traffic signals nor to hinder the use of public transit loading platforms.

2.2 Storage Requirement by Classification of Materials

Stored materials shall be separately stored under following classifications, with appropriate care necessary precautions to each classification.

- a) Climatically Sensitive Materials.
- b) Durable Materials.
- c) Materials Vulnerable to Rough Handling.
- d) Inflammable and/or Fire Sensitive Materials.
- e) Hazardous Materials.

Under each classification a list of commonly used materials are listed below. Other materials used but not mentioned here shall be treated under one or more of the above listed classifications which most closely match the unlisted material.

2.2.1 Climatically Sensitive Materials

Such material shall be stored in properly constructed sheds which must be stored in cool dry and well ventilated and confines, ensuring its storage without deterioration and without contact to ground and structural members, without exposure to moisture and heat, and away from direct sun.

Materials requiring breathing, such as timber and other natural products, shall be allowed ample air flow between successive layers of stacking.

Materials subject to deformation under stress shall be supported uniformly so as not to subject it to bending load or excessive vertical load.

Materials subject to loss of quality through moisture shall be kept within impermeable wrapping, if not used within a reasonable period.

2.2.1.1 Cement

Cement shall be stored at the work site in a building or a shed which is dry, leak proof and moisture proof. The building or shed shall have minimum number of windows and close fitting doors which shall be kept closed at all times except during loading and unloading.

Cement received in bags shall be prevented from coming into contact with any dampness or moisture. Cement bags shall be stacked on wooden planks maintaining a minimum clearance of 200 mm from the floor. A minimum clear space of 450 mm shall be provided between the stacks and any exterior wall.

Maximum height of the stack shall be 15 bags and the width not more than four bags or 3m. In stacks more than 8 bags high, the bags shall be arranged alternate length and crosswise. The bags shall be stacked closely as to minimize the surface area exposed to air.

During monsoon and for storage for more than 2 months, the stack shall be kept completely enclosed by a waterproofing membrane such as polyethylene sheet which shall close on top of the sack. Care should be taken to see that waterproofing membrane is not damaged any time during the use.

Heavy containers of cement shall not be stacked more than two tiers high. Cement shall be used in the order they are received; storage shall facilitate this requirement.

Hooks shall not be used for handling cement bags unless permitted by the supervisor. Workers handling cement shall put on protective hand and face coverings and use skin protective. They shall be instructed to the need of cleanliness from time to time.

When entering a silo or bin for any purpose, the workman shall wear a lifeline attended by another workman outside. The ejection system shall be shut down and locked out during such operation.

In case cement is received in silos, the silos shall be placed near the concrete batching plant. Proper access shall be provided for the replacement of silos.

Different types of cements shall be stacked and stored separately. In similar manner cements in gunny bags, paper bags and polythene sheets shall be stored separately.

2.2.1.2 Lime

Quicklime shall be slaked as soon as possible. If unavoidable, it may be stored in compact heaps having only the minimum of exposed area. The heaps shall be stored on a suitable platform under a roof protected from rain and wind. A minimum space of 300 mm shall be provided all-round the heaps to avoid bulging of walls.

Unslaked lime shall be stored in a watertight place and shall be separated from combustible materials.

Hydrated lime shall be supplied either in containers or sacks, such as jute bags lined with polyethylene or high density polyethylene woven bags lined with polyethylene or craft paper bags.

It shall be stored in a dry room to protect the lime from dampness and to minimize warehouse deterioration. The building should be with a concrete floor and having least ventilation to eliminate draughts through the walls and roof. In general, the recommendations given in storing of cement shall be applicable for hydrated lime. When air movement is reduced to a practical minimum, hydrated lime can be stored for up to three months without appreciable change.

When dry slaked lime is to be used within a few days, it shall be stored on a covered platform and protected from rain and wind. It shall be kept in a dry and air-tight go down when immediate use is not required. However, it shall never be stored for more than two months.

Handling of Cement and Lime

Bulk cement stored in silos or bins may fail to feed to the ejection system. When necessary to enter a silo or bin for any purpose, the ejection system employed shall be shut down and locked out electrically as well as mechanically, when necessary for a workman to enter such storage area, he shall wear a life-line, with another workman outside the silo or hopper attending the rope.

Workmen, handling bulk cement or lime shall wear protective clothing, respirators, and goggles; shall be instructed in the need of cleanliness to prevent dermatitis, and shall be provided with hand cream, petroleum jelly, or similar preparation for protection of exposed skin.

2.2.1.3 Timber

Timber shall be stored in stacks on well treated and even surfaced beams, sleepers or brick pillars so as to be at least 200 mm above the ground level. Contact with water shall be avoided under all circumstances. Members shall be stored separately in layers according to lengths and materials of equal lengths shall be piled together in layers with crossers or wooden battens of sound wood, straight and uniform thickness.

In any layer a 25 mm air space shall be kept between adjacent members. The longer pieces shall be placed in the bottom layers and shorter pieces in the top layers. At least one end of the stack shall be in true vertical alignment. The crossers themselves in different layer shall be in vertical alignment.

The recommended width and height of a stack are 1.5 m and 2.0 m respectively. Minimum distance between two stacks shall be 800 mm. In case stacking with battens is not possible, the timber may be close piled in heaps, and the precautions specified above observed.

All timbers to be stored for a year or more, the ends of members shall be coated with coal tar, aluminum leaf paints (hardened gloss oil), microcrystalline wax or other suitable material.

The stacks of timbers shall be protected from hot dry wind, direct sun and rain. Heavy weights may be placed on top of the stacks to prevent warping of timber. Nails, metal straps, etc. attached to used timber, particularly planks and formwork for shuttering shall be removed before stacking.

Care must be taken that handler or workmen are not injured by rails, straps, etc, attached to the used timber. This applies particularly to planks and formwork for shuttering.

2.2.1.4 Bamboo

The site shall be properly inspected and termite colonies or mounds if detected shall be destroyed. All refuse and useless cellulosic materials shall be removed from the site. The ground may then be disinfected by suitable insecticides. The area should have good drainage.

Bamboo may preferably be stacked on high skids or raised platform at least 300 mm above ground, Storage under cover reduces the liability to fungal attack. Good ventilation and frequent inspection are important.

Bamboo dries by air-seasoning under cover in the storage yards within 6 to 12 weeks time.

Prophylactic treatment of bamboo during storage prevents losses due to fungi and insects even under open storage. Following chemicals are found suitable at the coverage rate of 24 liters per ton.

Sodium Pentachlorophenate [1% solution]

Boric acid + Borax (1:1) [2% solution]

Sodium Pentachlorophenate + Boric acid + Borax (5:1:1) [2.5% solution]

Note: A mixture of these compounds yields the best results. For better protection of structural bamboo, (if stored outside) repetition of the treatment after four to six months is desirable.

2.2.1.5 Particle Board

See Sec 2.2.3.9.

2.2.2 Durable Materials

2.2.2.1 Steel Bars and Sections

Steel reinforcement bars and structural steel shall be stored in a way to prevent distortion, corrosion, scaling and rusting. Reinforcement bars and structural steel sections shall be coated with cement wash before stacking, especially in humid areas. In case of long time storage or storage in coastal areas, reinforcement bars and steel sections shall be stacked at least 200 mm above ground level.

Steel sections shall be stacked upon platforms, skids or any other suitable supports. Bars of different types, sizes and lengths and structural steel sections shall be stored separately to facilitate issues in required sizes and lengths without cutting from standard lengths. Ends of bars and sections of each type shall be painted with separate designated colors.

Tag lines shall be used to control the load in handling reinforcing bars or structural steel when a crane is used. Heavy steel sections and bundles of reinforcing bars shall be lifted and carried with the help of slings and tackles.

2.2.2.2 Bricks and Masonry Blocks

Bricks shall be stacked on dry firm ground in regular tiers. For proper inspection of quality and ease in counting, the stacks shall be 50 bricks long and 10 bricks high and not more than 4 bricks in width, being placed on edge two at a time along the width of the stack. Clear distance between adjacent stacks shall be not less than 800 mm.

Bricks of each truckload shall be put in one stack. Bricks of different types, such as, clay bricks, clay fly ash bricks, fly ash lime bricks, sand lime (calcium silicate) bricks shall be stacked separately.

Bricks of different classifications from strength consideration and size consideration (such as, conventional and modular) shall be stacked separately. Also bricks of different types, such as, solid, hollow and perforated shall be stacked separately.

Bricks made of clay containing lime shall be thoroughly soaked in water (docked) while in stack.

Bricks of different types shall be stacked separately. Concrete blocks, stone blocks and other masonry blocks shall be stored in stacks of such height as not to damage the blocks in the lower layers or topple.

Bricks shall be loaded or unloaded with care, and shall not be thrown or dumped. They shall be carried from the stack to the site of placement in small batches as and when necessary.

Brick stacks shall be placed close to the site of work so that least effort is required to unload and transport the bricks again by loading on pallets or in barrows. Unloading of building bricks or handling in any other way likely to damage the corners or edges or other parts of bricks shall not be permitted.

Blocks are available as hollow and solid concrete blocks, hollow and solid light weight concrete blocks, autoclave aerated concrete blocks, concrete stone masonry blocks and soil based blocks. Blocks shall be unloaded one at a time and stacked in regular tiers to minimize breakage and defacement. These shall not be dumped at site. The height of the stack shall not be more than 1.2 m, the length of the stack shall not be more than 3.0 m, as far as possible and the width shall be of two or three blocks. Normally blocks cured for 28 days only should be received at site. In case blocks cured for less than 28 days are received, these shall be stacked separately. All blocks should be water cured for 10 to 14 days and air cured for another 15 days; thus no blocks with less than 28 days curing shall be used in building construction. Blocks shall be placed close to the site of work so that least effort is required for their transportation. The date of manufacture of the blocks shall be suitably marked on the stacks of blocks manufactured at factory or site.

2.2.2.3 Stones

Stones of different sizes, types and classification shall be stored separately. Stones shall be stacked on dry firm ground in a regular heap not more than 1 m in height.

Veneering stones shall be stacked against vertical support on a firm dry ground in tiers up to a height of 1.2 m. A distance of about 0.8 m shall be kept between two adjacent stacks.

2.2.2.4 Aggregates

Aggregates shall be stored at site on a hard, dry and level ground. If such a surface is not available, a platform of planks or old corrugated iron sheets, or a floor of bricks, or a thin layer of lean concrete shall be used. Contact with clay, dust, vegetable and other foreign matters shall be avoided.

Fine and coarse aggregates shall either be stored separately or heaps be separated by dividing walls. Fine aggregate shall be stored in a place and manner where loss due to the effect of wind is minimum, viz. in the leeward side behind a wall, or by covering with a polyethylene sheet.

On a large job it is desirable to construct dividing walls to give each type of aggregates its own compartment. Fine aggregates shall be stacked in a place where loss due to the effect of wind is found minimum.

When withdrawals are made from heaps, no overhang in the original heap shall be permitted. Employees required to enter hoppers shall be equipped with safety belts and life-lines, attended by another person. Machine driven hoppers, feeders, and loaders shall be locked in the off position prior to entry electrically as well as mechanically.

2.2.2.5 Water

Water to be used in construction shall be stored in tanks, bottom and the sides of which shall be constructed with brick or concrete. Contact with any organic impurities shall be prevented. The total capacity of the storage tank shall be determined after taking into account the water required for firefighting. Also see Sec 4.2 of Chapter 4 Part 4.

The tank shall be so located as to facilitate easy storage and filling in, and supply both for construction work and for firefighting. Passage of water to the water tank shall not be blocked at any time.

2.2.3 Materials Vulnerable to Rough Handling

2.2.3.1 Aluminum Sections

Aluminum sections of different classification, sizes and lengths shall be stored separately, on a level platform under cover.

The aluminum sections shall not be pulled or pushed from the stack nor shall be slided over each other, to protect the anodizing layer.

2.2.3.2 Pulverized Fuel Ash/Fly Ash

Fly ash shall be stored in such a manner as to permit easy access for proper inspection and identification of each consignment. Fly ash in bulk quantities shall be stored in stack similar to fine aggregates, avoiding any intrusion of foreign matter. Fly ash in bags shall be stored in stacks not more than 10 bags high. For handling see Sec 2.2.1.2.

2.2.3.3 Cinder

Cinder shall be stored in bulk quantities in stacks similar to coarse aggregates avoiding any extrusion of foreign matter.

2.2.3.4 Pipes and Tubing

Pipes shall be stored in stacks with stoppers provided at the bottom layer to keep the pipe stack stable. The stack, particularly of smaller diameter pipes, shall be in pyramid shape. Pipes shall not be stacked more than 1.5 m high.

Each stack shall have pipes of the same type and size only. Removal of pipes shall start from the top layer and by pulling from one end. A pipe shall not be stored inside another pipe. The pipes may also be placed alternately length and crosswise.

Pipe shall be carried one at a time on shoulders by at least two workmen. Pipe fittings and joints shall be handled individually.

Black polyethylene pipes may be stored either under cover or in the open. However, natural coloured polyethylene pipes shall be stored under cover only and protected from direct sunlight.

Coils of tubing shall be stored either on edge or stacked flat one on top of the other; in either case they shall not be allowed to come into contact with hot water or steam pipes and should be kept away from hot surface.

Straight lengths of unplasticized PVC pipes shall be stored on horizontal racks supported throughout their lengths on a reasonably flat surface free from stones and sharp projections. Pipes shall not be stacked in large piles, especially under warm conditions. Socket and spigot pipes shall be stacked in layers with sockets placed at alternate ends of the stack to avoid top sided stack.

PVC pipes shall be stored in a shaded area. The ends of pipe, particularly those specially prepared for jointing, shall be protected from abrasion. Damaged portion of a pipe shall be cut out completely.

Pipes of conducting materials shall be stacked on solid level sills and contained in a manner to prevent spreading or rolling of the pipe. For storage in large quantity, suitable packing shall be placed between the layers. During transportation, the pipes shall be so secured as to prevent displacement/rolling.

In stacking and handling of pipes and other conducting materials, the following minimum vertical safety distances from overhead power lines shall be provided

11 KV and below	1.40 m
Above 11 KV and below 33 KV	3.60 m
Above 33 KV and below 132 KV	4.70 m
Above 132 KV and below 230 KV	5.70 m
Above 275 and below 400 KV	6.50 m

Handling: Removal of pipes from a pile shall be accomplished by working from the ends of the pipe. During transportation, the pipes shall be so secured as to ensure against displacement.

2.2.3.5 Timber Piles and Poles

Piles and poles shall be stacked on solid and level sills so as to prevent rolling or spreading of the stack. The storage area shall be maintained free of vegetation and flammable materials.

Removal of piles and poles shall start from the top layer and by pulling from one end. Tag lines shall be used to control movement of piles and poles. In stacking and handling of piles and poles, precautions as laid down in Sec 2.2.3.4 shall be followed.

2.2.3.6 Sanitary Appliances

All sanitary appliances shall be stored under cover to prevent damage. In receiving and storing appliances consideration shall be given to the sequence of removal from the store to the assembly positions. Vitreous fittings shall be stacked separately from the metal ones.

Bigger sanitary appliances shall be handled one at a time. Traps, water seals and gullies shall be handled separately. Sanitary fittings shall be protected from any oil spillages; hands of the workers shall be free of any oily substance. The supporting brackets, pedestals etc. shall be checked before lowering the appliances in their position.

2.2.3.7 Doors, Windows, Ventilators and Grilles

Metal and plastic doors, windows and ventilators shall be stacked upright (on their sills) on level ground preferably on wooden battens and shall not come in contact with dirt or ashes. If received in crates they shall be stacked according to manufacturer's instructions and removed from the crates as and when required for the work. Metal and plastic frames of doors, windows and ventilators shall be stacked upside down with the kick plates at the top. These shall not be allowed to stand for long in this manner before being fixed so as to avoid the door frames getting out of shape and hinges being strained and shutters drooping. During the period of storage of aluminum doors, windows and ventilators, these shall be protected from loose cement and mortar by suitable covering, such as tarpaulin. The tarpaulin shall be hung loosely on temporary framing to permit circulation of air to prevent moisture condensation. All timber and other lignocellulosic material based frames and shutters shall be stored in a dry and clean covered space away from any infestation and dampness. The storage shall preferably be in well-ventilated dry rooms. The frames shall be stacked one over the other distances to keep the stack vertical and straight. These cross battens should be of uniform thickness and placed vertically one above the other. The door shutters shall be stacked in the form of clean vertical stacks

one over the other and at least 80 mm above ground on pallets or suitable beams or rafters. The top of the stack shall be covered by a protecting cover and weighted down by means of scantlings or other suitable weights. The shutter stack shall rest on hard and level surface. If any timber or other lignocellulosic material based frame or shutter becomes wet during transit, it shall be kept separate from the undamaged material. The wet material may be dried by stacking in shade with battens in between adjacent boards with free access of dry air. Separate stacks shall be built up for each size, each grade and each type of material. When materials of different sizes, grades and types are to be stacked in one stack due to shortage of space, the bigger size shall be stacked in the lower portion of the stacks. Suitable pallets or separating battens shall be kept in between the two types of material. Precast concrete door and window frames shall be stored in upright position adopting suitable measures against risk of subsidence of soil support.

While unloading, shifting, handling and stacking timber or other lignocellulosic material based, metal and plastic door and window frames and shutters, care shall be taken that the pieces are not dragged one over the other as it may cause damage to their surface particularly in case of the decorative shutters. The pieces should be lifted and carried preferably flat avoiding damage to corners or sides.

Metal frames of doors, windows and ventilators shall be stacked with the kick plates at the top. They shall not be kept in this manner for long, and should be taken to the fixing position as soon as possible.

2.2.3.8 Floors, Wall and Roof Tiles

Floor, wall and clay roof tiles of different types, such as, cement concrete tiles (plain, colored and terrazzo) and ceramic tiles (glazed and unglazed) shall be stacked on regular platform as far as possible under cover in proper layers and in tiers and they shall not be dumped in heaps. In the stack, the tiles shall be so placed that the mould surface of one faces that of another. Height of the stack shall not more than 1000 mm. Tiles of different quality, size and thickness shall be stacked separately to facilitate easy removal for use in work. Tiles when supplied by manufacturers packed in wooden crates shall be stored in crates. The crates shall be opened one at a time as and when required for use.

Ceramic tiles and roof tiles are generally supplied in cartons which shall be handled with care to avoid breakage. It is preferable to transport these at the site on platform trolleys.

2.2.3.9 Sheets and Boards

For storing and handling of sheets and boards, such as CGI sheets, particle boards, gypsum boards etc., the following requirements shall be fulfilled:

- (a) sheets and boards shall be stacked to a height of not more than 1 m on dry, clean, firm and level ground with timber or other packing beneath them;

- (b) bottom of the stack shall be raised adequately from the ground level where there is a risk of water coming on the floor;
- (c) sheets and boards shall be stacked under cover and protected from damage due to wind, rain and sun;
- (d) at least one edge of the stack shall be in true vertical alignment; the top sheet in each stack shall be suitably weighed down;
- (e) damage to the corners and surface of sheets and boards shall be prevented and damaged sheets shall not be stacked with sound materials;
- (f) sheets shall not be pushed forward against the lower sheet for more than one-fourth of the sheet length;
- (g) they shall be lifted into position by two workmen, if necessary;
- (h) sheets and boards shall be lowered or raised gently and not thrown; and suitable hand protection like gloves, jelly etc. shall be provided to the workmen wherever necessary.

CGI sheets shall be stacked in not more than 100 bundles per stack built solidly. Corrugations of sheets in one stack shall run in the same direction. One end of the stack shall be raised by at least 100 mm to drain accumulated water, if any. Sheets not for immediate use shall be stacked under roof.

Plywood, fiber board, particle board, block board etc. shall be stacked on a flat dunnage on top of which a wooden frame shall be constructed with battens of suitable size in such a way that it supports all four corners and edges of the boards. For boards up to a length of 2 m, minimum of one intermediate batten and for boards longer than 2 m, at least two intermediate battens shall be provided to avoid warping.

Decorative plywood and laminated and decorative boards shall be stacked in pairs facing each other. Sheets shall not be dragged one over another.

Specification laid out in BDS 1159 shall be followed for packaging of plywood, particle board, hard board and flush doors.

2.2.3.10 Cast Iron, Galvanized Iron and Asbestos Cement Pipes and Fittings

The pipes shall be unloaded where they are required, when the trenches are ready to receive them. Storage shall be provided at the bottom layer to keep the stack stable. The stack shall be in pyramid shape or the pipes placed length-wise and cross-wise in alternate layers. The pyramid stack is advisable in smaller diameter pipes for conserving space in storing them. The height of the stack shall not exceed 1.5 m. Each stack shall contain only pipes of the same class and size. Each stack shall contain only pipes of same

class and size, with consignment or batch number marked on it with particulars or suppliers wherever possible. Cast iron detachable joints and fittings shall be stacked under cover. Rubber rings shall be kept clean, away from grease, oil, heat and light.

Pipes in the top layer shall be handled first. At a time only one pipe shall be handled by two laborers while conveying to the actual site and shall be carried on shoulders. Fittings shall be handled individually.

2.2.3.11 Glass Sheets

All glass sheets shall be kept dry and stored in a covered space. Glass sheets shall be lifted and stored upright on their long edges and put into stacks of not more than 25 sheets. They shall be supported at two points at about 300 mm from each end by fillets of wood.

The bottom of each stack shall be about 25 mm clear from the base of the wall and other support against which the stack rests. The whole stack shall be as close to upright as possible. Smooth floors shall be covered with gunny bags.

Workmen handling glass sheets, remnants and waste glass pieces, and fibre glass shall be provided with gloves, jelly and other suitable hand protections. In removing glass sheets from crates, great care shall be taken to avoid damages from breakage. Glass edges shall be covered or protected to prevent injuries to workmen.

2.2.4 Inflammable and/or Fire-Sensitive Materials

Materials under this classification shall be stored within fire-preventive confines, furnished with firefighting provisions. Buckets containing sand shall be kept ready for use. A 5 kg dry powder fire extinguisher conforming to accepted standards shall be kept at an easily accessible position. Besides the areas shall be close to fire hydrants.

2.2.4.1 Plastic and Rubber sheets

Plastic and rubber sheets shall be stored within fire proof confines according to manufacturer's instructions. Sheets shall be stored in the coolest of the store rooms available. The room shall be well ventilated and kept dark; direct sun light shall not be allowed to fall on the stored sheets.

The sheets shall be stored away from electric generators, electric motors, switchgears and other such electrical equipment.

Contamination of the sheets with vegetable and mineral oil, grease, organic solvents, acid and their fumes, alkalis, dust and grit shall be prevented. All greasy contamination shall be removed immediately with kerosene or similar liquid, and the sheets thoroughly wiped dry and dusted with French chalk.

Undue stretch and strain, kinks, sharp bends or folds of the sheets shall be avoided in case of long time storage. The sheets shall be turned over periodically and treated with fresh chalk.

In addition, safety precautions common for all types of sheets, as laid down in Sec 2.2.3.9, shall be followed.

2.2.4.2 Paints, Varnishes, Thinners, Bitumen and Road Tar

Paints, varnishes, lacquers, thinners and other inflammable materials shall be kept in properly sealed or closed containers. The containers shall be kept in a well-ventilated location, free from excessive heat, smoke, sparks or flame. The floor of the paint store shall have 100 mm thick loose sand on it.

Paint materials in quantities other than required for daily use shall be kept stocked in the regular storage place. The manner of storage shall facilitate removal and use of lots in the same order in which they are received.

Temporary electrical wiring and fittings shall not be installed in the paint store. When electric lights, switches or electrical equipment are necessary to be stored or used in the same room, the room shall be designed in a way to reduce explosion risk.

Sources of ignition, such as open flame and exposed heating elements, shall not be permitted in paint store, nor shall smoking be allowed there.

Drums or containers containing bitumen, road tar, asphalt, etc. shall be stacked vertically on their bottoms in up to 3 tiers. Leaky drums shall be either totally removed or separated. Empty drums shall be stored in pyramidal stacks neatly in rows.

Bituminous roofing felts shall be stored away from other combustible or flammable materials. They shall be handled gently to prevent cracking and damages.

Workers engaged on jobs involving handling of hot bitumen, tar, and bituminous mixtures shall use protective wears, such as boots and gloves of rubber, goggles and helmet. No workers shall be permitted to handle such materials without wearing the needed protective covering.

Bitumen/tar shall not be heated beyond the temperature recommended by the manufacturer of the product. While discharging heated binder from the boiler, workers shall not stand opposite to the jet so as to avoid the possibility of hot binder falling on them. The container shall be handled only after closing the control valve. While handling hot bitumen/tar, workers shall exercise scrupulous care to prevent accidental spillage thereof. The buckets and cans in which the hot material is carried from boiler shall be checked before use to ensure that they are intact and safe. Mops and other applicators contaminated with bituminous materials shall not be stored inside buildings.

Outdoor storage of drums containing flammable materials like hydraulic brake and transmission fluid, gasoline and lubricants shall be such that contamination from moisture and dirt is avoided.

The storage shall be free of spilled products, debris and other hazardous material.

Compressed gases and petroleum products shall not be stored in the same building or close to each other. Proper identification by markings, tags etc. shall be used for petroleum products delivered to the job site and stored there in drums.

Highly flammable liquids shall be stored in fire resisting containers in a special store room secluded from the main working site. For uses of up to 50 litres, liquids can be stored in the workroom in fire resistant cupboards or bins. Stores of liquids shall be clearly marked highly flammable. All empty containers shall be returned to the store.

The workmen shall dispose of any clothing or apparel spilled over by or soaked in flammable materials immediately. They shall not be allowed to continue work unless affected clothing and apparels are changed.

2.2.5 Hazardous Materials

Materials under this category are (a) those posing health hazard through breathing, such as asbestos, glass fibre, etc. or injurious and/or intoxicating fluids of various kinds, (b) materials corrosive to living bodies and (c) materials likely to explode under heat or pressure. These should be stored in a manner specific to its properties, so as to prevent hazards of all kinds.

2.2.5.1 Asbestos-based Materials

Whenever possible, materials which do not contain asbestos shall be used. Special precautions as specified by the following sub-sections shall be taken while handling asbestos containing materials to minimize the risk of inhaling asbestos. Handling shall be limited to as few workers as possible.

(a) Handling of Asbestos-based Materials

When cutting, sawing or machining takes place in confined place efficient local dust extraction equipment shall be installed. Alternatively, a wet method of machining by water type dust suppressed powered tools shall be used.

The best standards of good housekeeping and hygiene shall apply to cutting areas which shall be segregated and used for no other purpose. Waste materials and dust shall not be allowed to accumulate in working area or store.

A vacuum cleaning device with a high efficiency filter shall be used to keep floors, walls and fixtures free from dust accumulation. Alternatively all surfaces shall be cleaned with a wet rag and floors washed by gently spraying water. Dry sweeping or compressed air blowing shall never be used.

Asbestos insulation boards shall preferably be supplied pre-cut and drilled from the workshop using a suitable dust control equipment. On-site preparations shall be performed in the open.

Polyethylene sheet shall be used to screen a work area in an enclosed space. Only authorized workers shall be allowed access to such areas. Appropriate signs shall mark an asbestos working area and warn against inhaling asbestos dust.

A guillotine or knife die cutter shall be used to cut sheets. The use of hammer and chisel shall be avoided.

At the end of each work shift, dust shall be either collected by a vacuum cleaner or swept up after being wetted. The dust shall then be put into a sealable container. Any rejected material shall also be placed in an impermeable bag.

(b) Removal and disposal Asbestos-based Materials

Spray method shall be used for removal of asbestos-based materials which is not covered or coated by other materials. For removing thick asbestos-based materials, soaking method with total saturation shall be used. Dry method shall only be used where the spray or soaking method cannot be used.

All moveable furniture and fittings shall be removed from the work area and other non-removable items covered with plastic sheets. Air conditioning systems shall either be isolated from the asbestos removal area or closed down.

Before removal or stripping the asbestos, insulation coatings shall be thoroughly soaked with water or steam. In case of dry demolition of asbestos, a portable exhaust extraction plant shall be used.

Transport and storage containers shall be labeled of the contents. Waste shall be kept in strong enclosed containers or in strong sealed impervious bags. These shall not be overfilled; care shall be taken to avoid damage or spillage before disposal.

The filter bags used in a dust extracting system shall be impermeable and capable of being readily sealed and disposed of without further treatment.

(c) Protective Clothing and Equipment

Workmen engaged in works using asbestos-based material, shall wear a full body coveralls with pockets, and close fitted cuffs and necks together with a head cover. Protective clothing shall also be worn by all persons in an area into which asbestos dust is liable to escape.

The clothing shall be made of synthetic fiber. Wet weather overalls which can be hosed down may be used.

The use of suitable working clothing shall not be necessary when minor handling of asbestos containing insulation is carried out provided adequate dust control techniques are employed.

Whenever, work methods create asbestos dust, suitable protective respirator shall be used.

Respiratory protective equipment shall be properly maintained and regularly cleaned and serviced.

Every person required to use protective equipment shall be fully instructed and trained in its use.

Protective clothing and equipment shall be regarded as the means of last resort and used as a back-up of other techniques, or where effective asbestos dust control cannot be achieved by other means.

(d) Personal Hygiene

Changing room and shower facilities shall be provided for the exclusive use of persons working in an asbestos working area. Locker accommodation shall be provided for every person required to wear respirators and coveralls.

Lockers for work clothes shall be separated from others. Contaminated clothing shall be placed in a dustproof container immediately on removal. Contaminated clothing or belongings shall not be shaken or brushed. These shall be superficially cleaned by vacuum cleaning or hosing down with water.

Food and drinks shall not be handled, stored or consumed in the asbestos work area. Smoking shall be prohibited. Workmen shall take shower before changing back into their own clothing; work clothing shall not be taken home. Parts of the body exposed to asbestos dust shall be thoroughly washed after completion of the job or before taking any meal.

Asbestos workers shall have a full size chest X-ray before commencement of work and also yearly. The reports shall be kept properly by the contractor for ready reference.

2.2.5.2 Acids and Other Corrosive Materials Working with Acid/Chemicals

When working with acids, bases, or other chemicals, one shall wear the proper clothing. The following are the five clothing items that shall be used while working with chemicals.

- (a) Safety glasses/goggles: Should completely cover your eye at all times.
- (b) Safety face shield: Wear over the top of any safety glasses or goggles.

- (c) Full-length acid smock: Wear over the clean-room clothing.
- (d) Rubber gloves: Wear with a two-inch cuff. This prevents acid from running down your arm. Also, inflate with nitrogen and submerge in water to check for pinhole leaks before using.
- (e) Hard leather or other non-porous shoes.

2.2.5.2.1 Transporting Acid/Chemical

The acid/chemicals used in work shall be stored in glass or plastic bottles. Transport of these chemicals shall be made by hand in a rubber or plastic bucket. If the bottle breaks or the lid leaks, the chemical will be contained in the bucket.

While transporting Acid/Chemical following rules shall be followed:

Actions to be done	Prohibitions
✓ Use the appropriate size of container for the job.	☒ Do not reuse containers (adverse chemical reaction may occur).
✓ Get help when needed.	☒ Do not eat, drink, smoke, or touch any part of the body before washing your hands when working with chemicals.
✓ Clean containers after use with deionized water.	☒ Do not be afraid to ask questions.
✓ Work under a fume hood.	☒ Do not pour leftover chemicals back in its source container; that may result in contamination.
✓ Use a funnel when pouring chemicals into a small container.	☒ Do not put your face close to the bottle when pouring.
✓ Open bottles slowly to avoid spilling and allow vapors to escape.	☒ Do not puncture cap or lid of any bottle.
✓ Know what type of reactions to expect.	
✓ Remember to triple-A (AAA): Always Add Acid to water.	

2.2.5.2.2 Storage of Acid/Chemical

Proper storage of the acid/chemicals will ensure everyone's safety. Therefore when storing acid/chemical the following care shall be taken:

- (a) Store acids and bases in separate cabinets.
- (b) Keep acids and solvents in different cabinets.
- (c) Label shelves for quick chemical identification.

- (d) Make sure that incompatibles are not stored on the same shelf.
- (e) Keep same shaped bottles on the same shelf to conserve shelf space.
- (f) Never store chemical containers anywhere except in designated cabinets.

When need to use the acid/chemicals:

- (a) Take the oldest container whose shelf life has not expired.
- (b) Make sure the container is sealed when you return it.
- (c) Always return the container to its labeled shelf.

2.2.5.3 Explosives

(a) Transportation of Explosive

Loading, unloading and handling of explosives will be supervised by competent personnel. The safety provisions of Sections 4.1 and 4.3, Chapter 4 of this Part shall also be applicable.

Where the magazine is located near the construction site and blasting operations continue daily, actual requirements of explosives shall be issued from the magazine and transported to the site. Any leftovers shall be returned to the magazine after every use.

For carrying up to 5 kg of explosives, insulated containers constructed of minimum 50 mm thick finished wood or 6 mm thick plastic or 10 mm thick pressed fiber shall be used. The containers shall have no metal parts, be waterproof and provided with a lid and nonconductive carrying device.

Vehicles transporting explosives shall have a wooden or non-sparking metal floor with high sides and ends. In open-bodied vehicles, the explosives shall be covered with a waterproof and fire-resistant tarpaulin. Electric wiring in vehicle shall be fully insulated. The nature of cargo in the vehicle shall be properly indicated on its body.

Metal, flammable, or corrosive substances shall not be transported with explosives. Explosive and detonators or blasting caps shall not be transported in the same vehicle; they shall be transported in original containers or in securely locked separate nonmetallic containers.

Smoking shall be prohibited in the vehicle carrying explosives.

(b) Storage of Explosives

Explosives shall only be stored in remote and isolated structures of substantial construction and blast-release isolated yards. The storage area shall be clean, dry, well ventilated, and cool. The material shall not be stored near oil, gasoline, cleaning solutions, radiators, steam pipes, or other sources of heat.

Storage shall require bullet and fire-resistant magazine. Blasting caps or primers shall not be stored with explosives.

Smoking, matches, fire or flame shall not be allowed near a magazine. No leaves, grass, bush or debris shall be allowed to accumulate within 8 m of an explosive magazine. No sparking metal or tools shall be stored in a magazine. Persons shall put off shoes with metal nails before entering a magazine.

If nitroglycerine leaks down on the floor, the floor shall be immediately desensitized by washing thoroughly with an agent obtained beforehand from the supplier of the explosives.

(c) Handling of Explosives

No package containing explosives shall be dragged, dropped or handled roughly. These shall be opened only at a safe distance and properly shielded from the packages of explosives in bulk storage. The covers of the explosive cases or packages shall be replaced every time after taking out part of the contents.

Sparking metal tools shall not be used to open kegs or cases of explosives. Smoking or carrying matches, fire, flame or devices capable of producing fire or flame, shall not be permitted while handling or using explosives. Explosives shall not be carried in the pockets of any clothing or on any person.

(d) Disposal of Explosives

No explosives shall be abandoned. They shall be disposed of in accordance with the approved methods; manufacturers or the appropriate authority shall be consulted in this matter.

Explosives caps or packing shall not be left lying around. Paper of fiber materials used in packing explosives shall not be put in any subsequent use. Such materials shall be destroyed by burning.

2.3 Miscellaneous

Small articles like screws, bolts, nuts, door and window fittings, polishing stones, protective clothing, spare parts of machinery, linings, packing, water supply and sanitary fittings, and electrical fittings, insulation board etc. shall be kept in suitable and properly protected containers, boxes or store rooms. Valuable small materials shall be kept under lock and key.

Polymeric materials such as coating, sheeting, reflective surfacing/sheeting, etc. shall be stored as per the manufacturers' instructions. Special precautions shall be taken in case of storage, handling and usage of toxic materials.

2.4 Special Considerations

Materials constantly in use shall be relatively nearer the place of use.

Heavy units like precast concrete members shall be stacked near the hoist or the ramp.

Materials which normally deteriorate during storage shall be kept constantly moving, by replacing old materials with fresh stocks. Freshly arrived materials shall never be placed over materials which had arrived earlier.

Appropriate types of fire extinguishers shall be provided at open sites where combustible materials are stored and for each storage shed room where flammable/combustible materials are stored. For guidance regarding selection of the appropriate types of fire extinguishers reference may be made to good practice. It is desirable that a minimum of two extinguishers are provided at each such location.

Workers handling excavated earth from foundation, particularly if the site happens to be reclaimed area or marshy area or any other infected area, shall be protected against infection affecting their exposed body portions.

2.5 Loading and Unloading of Materials

(a) Loading and Unloading Railway Wagons and Motor Vehicles

Each workman shall be instructed for the proper method of loading and unloading from rail wagons and motor vehicles, and provided with necessary equipment for safety. Supervisors shall ensure that the required number of workmen based on the weight and the distance involved in each job is available and engaged for the particular job.

Warning signals shall be displayed to indicate that the rail-wagons must not be coupled or moved while loading and unloading are carried out. The wheels of wagons and vehicles shall always be sprigged or chained while these are being unloaded; brakes alone shall not be relied upon.

Special lever bars, rather than ordinary crowbars, shall be used for moving rail wagons. Where gangplanks are used, either cleats at lower end of gangplank or pin through end of gangplanks shall be used to prevent sliding and slipping. If the gangplank is on a slope, cleats or abrasive surface shall be provided for the entire length.

When rail road wagons and motor vehicles are being loaded or unloaded near passageways or walkways, adequate warning signals shall be placed on each end of the way.

(b) Manual Handling

Loading and unloading of heavy items shall be done with cranes or gantries, if available. The workmen shall stand clear of the path of the material being moved by mechanical equipment. The slings and the ropes used shall be of adequate load carrying capacity.

For loading heavy and long components manually into motor vehicles, rail wagons, trailer etc., either wooden sleepers or steel rails of sufficient length and properly secured in position shall be put against the body of the wagon/vehicle at three or four places. The slope of such makeshift ramp shall be less than 30° with horizontal.

Long items shall be dragged, one by one, gently and uniformly along the ramps by means of ropes (tag). Workmen pulling long items shall anchor their feet against a firm surface.

Loaded items may be shifted by crowbars and other suitable leverage mechanism in their right position. These shall not be pushed or moved by hand. Similar procedures as outlined above shall be followed for manual unloading of long or heavy items.

For regular and frequent handling, the maximum load a single workman is subject to carry shall be limited to 20 kg. Workmen to carry heavier loads shall be specially selected, and if necessary, trained.

While lifting a load, the body shall be kept upright; weight shall be distributed evenly and supported on the bone structure, and held close to the body. Advantage shall be taken of any device provided for assistance.

PART VII
Chapter 3
Safety During Construction

3.1 General

3.1.1 Scope

The provisions of this Chapter shall apply to the safety of life and property during construction, erection and alteration of various parts of a building or any other structures. Nothing stated herein shall be construed to nullify any rules, regulations, safety standards or statutes of the local authority, Corporations, or those contained in the various Acts of the Government of Bangladesh. The specific rules, regulations and acts pertaining to the protection of the public or workmen from health and other hazards wherever specified by the local Authority/Corporation etc. or by the Act/Ordinance of the Government shall take precedence over whatever is herein specified.

3.1.2 Safety Management

The safety of personnel engaged in building construction shall be ensured through a well-planned and well organized mechanism. For this, depending on the size and complexity of building construction project, safety committee shall be constituted to efficiently manage all safety related affairs. The site in-charge or his nominee of a senior rank shall head the committee and a safety officer shall act as Member Secretary. The safety committee shall be organized a training program for the personals and workers to train up them about safety issues involved in the construction process and also organize meeting of the committee regularly say fortnightly or monthly depending on the nature of the project, however, emergency meetings shall also be called as and when required. The safety committees shall deal with all the safety related issues through well-structured agenda, in the meetings and all safety related measures installed at the site and implementation thereof shall be periodically reviewed.

3.2 Terminology

For the purpose of this Part the following definitions shall apply.

AUTHORITY HAVING JURISDICTION	The Authority which has been created by a statute and which for the purpose of administering the Code/Part, shall authorize a committee or an official to act on its behalf; hereinafter called the 'Authority'.
CONSTRUCTION EQUIPMENT	All equipment, machinery, tools and temporary retaining structures and working platforms, that is, tools, derricks, staging, scaffolds, runways, ladders and all material, handling equipment including safety devices.

FLOOR HOLE	An opening measuring less than 300 mm but more than 25 mm in its least dimension, in any floor, platform, pavement, or yard, through which materials but not persons may fall; such as, a belt hole, pipe opening or slot opening.
FLOOR OPENING	An opening measuring 300 mm or more in its least dimension, in any floor, platform, pavement or yard through which person may fall; such as hatch way, stair or ladder opening, pit or large manhole.
GUARD RAILING	A barrier erected along exposed edges of an open side floor opening, wall opening, ramp, platform, or catwalk or balcony, etc, to prevent fall of persons.
MATERIALS HANDLING HOISTS	A platform, bucket or similar enclosure exclusively meant for the lifting or lowering of construction material the hoists being operated from a point outside the conveyance.
PILE RIG	The complete pile driving equipment comprising piling frame, leader, hammer, extractor winch and power unit. Complete pile driving rig shall be mounted on rafts or pontoon or rails. Pile rig shall also be a mobile unit mounted on trailers or trucks, or a special full revolving rig for raking piles.
PLATFORM	A working space for persons, elevated above the surrounding floor or ground, such as balcony or platform for the operation of machinery and equipment.
SCAFFOLD	A temporary erection of timber, bamboo or metal framework used in the construction, alteration or demolition of a building, to support or to allow the hoisting and lowering of workmen, their tools and materials.
TOE BOARD	A vertical barrier erected along exposed edge of a floor opening, wall opening, platform, catwalk or ramp to prevent fall of materials or persons.
WALL HOLE	An opening in any wall or partition having height of less than 750 mm but more than 25 mm and width unrestricted.
WALL OPENING	An opening in any wall or partition having both height of at least 750 mm and width of at least 450 mm.

3.2.1 Safety of Workmen

Helmets conforming to BDS 1265 and BDS 1266 shall be worn by the workmen and other personnel at all times during the work. Safety goggles of accepted standard (BDS 1360) shall be used by individuals engaged in drilling, cutting, welding and all such works which cause hazard to the eye. The welders and gas cutters shall be equipped with proper protective equipment like gloves, safety boots, aprons and hand shields having filter glass of accepted standard and suitable to the eyes of the particular worker.

3.2.2 Site Precautions

Construction site shall be delineated, in absence of boundary walls, by fences. During the erection of tall buildings, nylon net shall be put around the building periphery 3 m to 4 m below the working level.

Warning signs shall be displayed, where necessary, to indicate hazardous areas like high voltage zone, area of no smoking etc. Hand lamps shall be of low voltage, preferably 24V. All electrically operated hand tools shall be provided with double earthing.

3.2.3 Site Amenities

Toilet facilities shall be provided at all construction sites. If sewer connection is not available, temporary wells shall be used. The wells shall be provided with proper covers, bad smell protector and have to clean regularly.

Men and women workers shall be provided with separate sanitary and washing facilities.

The toilet facilities shall be located at a corner of the site so as to avoid any obstruction. Protection from bad weather and falling object, and proper privacy shall be provided to the toilet users.

Temporary toilets shall be dismantled, all wells filled up, and the whole area made level, dressed and restored back to proper grade at the end of the project. All temporary sewer connections shall be removed and the sewer capped.

Washing facilities provided at the site shall be connected to the available running water supply.

Drinking water shall be supplied to the site. In absence of any water supply facility at the site, hand tube wells shall be sunk to meet the requirements of drinking and washing.

Numbers of the sanitary and plumbing facilities required in a construction site shall be regulated by the 1965 Factories Act, and Part 8 Chapters 5 and 6.

Proper accommodation for taking meals and for taking shelter during interruption of work in night time and due to adverse weather condition with amenities of sleeping bed including provision for lights and fans have to provide.

3.3 Excavation and Foundation Work

3.3.1 General

The requirements of this Section shall be satisfied in addition to those of Sec 3.12 Part 6 for all excavation and foundation works.

The distribution of the supporting foundation shall be such as to avoid any harmful differential settlement of the structure. The type and design of the foundation adopted shall ensure safety to workmen during construction and residents of the neighboring property. Sufficient care shall be taken in areas, where withdrawal of ground water from surrounding areas could result in damages to such foundations. During the construction of the foundation, it shall be ensured that the adjoining properties are not affected by any harmful effects.

The process of excavation, filling in, pumping etc. shall avoid endangering the strength or stability of the partially completed structure. The partially completed structure shall be capable of carrying loads previously taken by temporary works which, as part of the construction procedure, have to be transferred before the completion of the work.

Excavation with intervals on any site shall be avoided. If such excavation is unavoidable, the excavated site shall be properly fenced and warning signals.

Excavation of interrupted or temporarily suspended construction shall be either backfilled or barricaded.

During construction, inspection shall be made by the engineer-in-charge to ensure that all protective works carried out to safe-guard the adjoining property are sufficient and in good order to ensure safety.

Arrangements for safe movement of workers and inspectors in the trench have to be planned and provided.

Before carrying out any excavation work/pile driving, the position, depth and size of underground structures, such as water pipes, mains, cables or other services in the vicinity to the proposed work, shall be obtained from the appropriate Authority to prevent accidents to workmen engaged in excavation work and calamities for the general public. Prior to commencement of excavation detailed data of the type of soils that are likely to be met with during excavation shall be obtained and the type of protective works by way of shoring timbering, etc, shall be decided upon for the various strata that are likely to be encountered during excavation. For detailed information regarding safety requirements during excavation reference shall be made to good practice.

3.3.2 Excavating Machinery and Tools

Heavy equipment, such as excavating machinery, shall be kept away from the trenches by a distance at least equal to the depth of trench to a maximum of 6 meters. All excavating tools shall be kept far away from the edge of trench.

3.3.3 Excavated Materials and Surcharges

Excavated materials shall be kept away from the edges of the trench to provide a clear berm of safe width. Where this is not feasible, the design of protection for the trenches shall include the additional load due to the materials.

Proximity of buildings, piles of lumber, crushed rocks, sand and other construction materials, large trees, etc. may impose surcharges on the side of the trench to cause bulging, sliding, etc.

Additional protective measures shall be taken to support the sides of the trenches under these conditions. The objects creating such threat shall be removed if possible before excavation starts.

3.3.4 Ground Water

Where deep excavation is required, the location of water-bearing strata shall be determined and the water pressure observed to take necessary precautions. Direction of natural drainage shall be determined to facilitate the design of intercepting drains to prevent the influx of ground water.

In areas where the ground water or soil contains constituents in amounts sufficient to cause damage to cement or buried metals, a chemical analysis of samples of ground water and soil shall be obtained and necessary precautions taken.

Basements or pits below ground water level, which rely on the weight the superstructure for their stability against floatation, shall be pumped day and night. Protective filters shall be used during heavy pumping in excavations. The water shall be drawn away from the excavation rather than through the ground towards the excavation.

3.3.5 Ground Condition

Adequate precautions, depending upon the type of strata met with during excavation (like quick sand, loose fills and loose boulder) shall be taken to protect the workmen during excavation. Effect of climatic variations and moisture content variations on the materials under excavation shall be constantly watched and precautions taken, where necessary, immediately to prevent accidents at work site.

Where portions of the foundation are underlain by soft materials or where the layers of such materials vary in thickness, the assessment of allowable bearing pressure shall require a settlement analysis.

Site investigations shall be sufficiently extensive to ensure that significant variations in strata thickness are detected. If required, either the resistance of the inclined or jointed strata shall be increased or the foundations shall be carried deep enough to prevent sliding.

Precautions, against pockets of poisonous/dangerous gases including protection to the workmen, shall be taken during deep excavation. Effect of climatic variations and variation in moisture content of the soil shall be constantly monitored and precautions taken immediately, when necessary.

3.3.6 Overhang, Slopes and Cavities

Overhangs in the trenches shall be supported by props. Use of heavy machinery shall be avoided under or over this area.

Where climatic or other conditions may result in deterioration of the sides of excavation, consideration shall be given to their support and protection. During excavation, adequate protections justified by established method of analysis shall be taken to prevent slope instability.

3.3.7 Blasting and Vibration

Blasting for foundation of buildings is prohibited unless special permission is obtained from the Authority. Where blasting technique is to be used, an analysis for the stability of slopes shall be carried out and steps be taken accordingly.

Attention shall be given to the geological strata of the site to ensure that it is not liable to transmission of ground vibration to areas where it may cause damage to property or the ground.

After blasting, overhangs or loose boulders shall be cleared off the site. In all excavation works, precautions shall be taken to eliminate/reduce vibration generated by adjacent machinery, vehicles, railroads, blasting, piling and other sources.

Appropriate authorities shall be notified in advance of any blasting operations when these are to take place close to public roads and railways. Also see Sec 4.3.

3.3.8 Health Hazards during Excavation

Mechanical ventilation shall be provided where gases or fumes are likely to be present in trenches.

All personnel working there shall be provided with protective respiratory equipment. All trenches/tunnel shall be provided with emergency exits (Sections 3.11.2 and 3.11.3).

The precautionary measures provided shall meet the requirements of the local health authority.

The owner shall ensure that all precautionary measures have been taken and been inspected by the appropriate Authority prior to commencement of such work.

3.3.9 Safety of Materials

Materials required for excavation, like ropes, planks for gangways and walkways, ladders, etc. shall be inspected by the Engineer-in-charge who shall ensure that no accident shall occur due to the failure of such materials (see Part 5 of this Code).

(a) Fencing, Warning Signs and Watchman

Where excavation is going on, for the safety of public and the workmen, fencing shall be erected.

Sufficient number of notice boards and danger sign lights shall be provided in the area to avoid any member of public from inadvertently falling into the excavation. When excavations are being done on roads, diversion of the roads shall be provided with adequate notice board and lights indicating the diversion well ahead. Where necessary, recourse shall be had for additional precautionary measures by way of watchmen to prevent accident to the general public, especially during hours of darkness. If necessary, watchmen shall be employed as an additional precautionary measure to prevent any accident, especially during the night.

(b) Vibrations from Nearby Sources

Vibration due to adjacent machinery, vehicles, railroads, blasting, piling and other sources require additional precautions to be taken.

(c) Precautions While Using Petroleum Powered Equipment

At the site of excavation, where petroleum powered equipment is used, petroleum vapors are likely to accumulate at lower levels and may cause fire explosion under favorable circumstances. Care shall, therefore, be taken to avoid all sources of ignition in such places.

3.3.10 Piling and Deep Foundation

All piling and deep foundation operations shall be supervised by a competent Geotechnical Engineer. He shall also be responsible for the precautionary measures to be taken.

For work during night, lighting of at least 100 lux intensity shall be provided at the work site. In excavations deeper than 1.5 m, ladders, ramps or other means of escape, and staging shall be provided.

Every crane driver or hoisting appliance operator shall be competent to the satisfaction of the engineer-in-charge and no person under the age of 21 years shall be in-charge of any hoisting machine including any scaffolding winch, or giving signals to operators.

3.3.11 Working in Compressed Air

Working in compressed air, in case of deep foundations, requires several precautions to be observed to safeguard the workmen against severe hazards to life, compressed air disease and related ailments.

Filtered compressed air shall be supplied to a working chamber sufficient to provide 0.3 m³ of fresh air per minute per person at the pressure in the chamber. Means for the escape of foul air, as well as circulation of fresh air in the chamber, shall be ensured.

Hot drinks shall be supplied to workmen employed in compressed air after leaving the chamber. No person shall carry any flammable materials inside the air-lock and nobody shall be allowed to smoke inside. Only approved type of lamps and torches shall be used. Lighting of at least 4.5 lux intensity shall be provided.

Methanometer shall be used to detect hazardous gases. Samples of air inside the well shall be taken every eight hours and tested for the presence of hazardous gases and for deficiency of oxygen. In case any hazardous gas is detected, it shall be immediately reported to the engineer and the work in the compressed air stopped.

The pressure in the chamber, in the first minute, after starting compression shall be increased to 35 kPa. It shall not be further increased until the lock attendant has checked whether or not there are complaints of discomfort. The pressure shall then be increased at a rate of 65 kPa/min. If any person complains of discomfort, the proceeding compression shall be immediately stopped and the person evacuated unless he feels comfortable again in a reduced pressure.

In case of airlocks where blasting is done, the workmen shall be permitted to start work only after an inspection by a competent professional found it to be safe. Air required for pneumatic tools shall be cooled and purified in the same way as air for working chamber.

Every man lock shall have a minimum head room of 1.8 m and at least 0.85 m³ of space per person. It shall be suitably equipped with an accurate pressure gauge, clocks, and efficient means to convey visible or nonverbal signals to the lock attendant outside. All electrical installations inside the airlock shall be of flame proof type.

All equipment shall be thoroughly inspected after every 45 days of working and every time it is shifted and reinstalled, and certified to be in a safe working condition by a competent person. A record of all such inspections shall be kept in a register.

The receiver shall be capable of maintaining the working pressure for at least four hours. Adequate access through the bulk heads and sufficient ladders shall be provided. Escape routes in tunnels shall be in the corner. Whilst any person is in a working chamber, the door between such chamber and any man-lock providing egress towards a lower pressure shall be kept open.

No person shall be in a working chamber under pressure where the wet bulb temperature exceeds 29°C measured by a thermometer using nontoxic materials.

No person shall be employed on work in compressed air unless under the supervision of a person experienced in such work. No person shall be employed where the pressure exceeds 120 kPa unless he has, within the previous four weeks been examined and certified to be fit for employment in compressed air. If a person is suffering from cold in head, sore throat, earache etc., he/she shall not be employed in compressed air. Finally work in compressed air shall be carried out only by workers whose physical aptitude for such work has been established by a medical examination and when competent person is present to supervise the conduct of the operations.

Where the pressure exceeds, a suitably constructed medical-lock shall be provided. It shall have two chambers, and doors fitted with bulls' eyes and air valve. The lock shall have couch, blanket, dry woolen garments, food etc. The medical lock shall be supplied with air, free of oil and carbon monoxide, and capable of raising the pressure from 0 to 520 kPa in 5 minutes.

3.3.12 Adjoining Properties and Service Lines

Where bored or driven piling works are to be carried out in the vicinity of old structures which are likely to be damaged, tell-tales shall be fixed on such structures to monitor their behavior while piling is in progress; timely precautions shall be taken against any adverse effect.

Steps shall be taken, if necessary, to increase the general stability of the construction site or the adjoining site(s), before new structures are erected. In all cases, the possible effect of slopes and excavation of foundation stability shall be carefully investigated.

Before excavation or pile driving, information on the location of underground utility connections shall be obtained from the relevant authorities. Probable extent of all damages due to pile driving to adjoining structures or service lines shall be ascertained in advance of operation; pile driving shall be planned accordingly, especially in the case of pre-cast pile driving.

If excavation involves cutting through existing land drains, they shall be carefully diverted into the ground drainage system. All other precautionary measures required by Sec 1.5 of this Chapter shall also be taken.

3.4 Pile Rig

3.4.1 Erection of Pile Rig

The frame of the rigs shall be structurally safe for all anticipated dead, live and wind loads.

Whenever the structural strength is in doubt, suitable test shall be carried out by the engineer and the results recorded. No pile driving equipment shall be used until it has been inspected and found safe.

When two or more pile drivers are used at the same location, they shall be separated by a distance at least equal to the longest leg of either rig.

Pile drivers shall be firmly supported on heavy timber sills, concrete beds or other secure foundations. If necessary, pile drivers shall be adequately guyed. Rigs not in use shall be supported by at least three guys to withstand wind, storm, gales and earthquake.

3.4.2 Operation of Pile Rig

Access to working platforms and top of pulley shall be provided by ladders. Working platforms shall be protected from wind and rain. Ladder in regular use in tall driven piling rigs, or rigs of similar nature, shall be securely fastened and extended for the full height of the rig.

Exposed gears, flywheels, etc. shall be fully enclosed. Motor gearing, transmission, electrical wiring and other parts of a hoisting machine which are sources of hazard shall have proper safeguards.

To operate energized electrical installations, insulating mats and wearing apparel, such as gloves, etc. shall be used. Sheaves on pile drivers shall be guarded against workers drawn into them accidentally.

No steam or air driven equipment shall be repaired while it is in operation or under pressure.

Steam and air lines shall be controlled by easily accessible shut-off valves. These lines shall consist of armoured hose or its equivalent.

The hose of steam and air hammers shall be securely lashed to the hammer so as to prevent it from whipping if a connection breaks. Couplings of sections of hose shall be additionally secured by ropes or chains. When not in use, the hammer shall remain in dropped position held in place by a cleat, timber or other suitable means.

Hoisting appliances shall be provided with means to reduce the risk of accidental descent of the load. Adequate precautions shall also be taken to reduce the risk of any part of suspended load becoming accidentally displaced. Care shall be taken to prevent the hammer from missing the pile.

Loads shall be adequately counter-balanced, and the tilting device secured against slipping.

Precautions in the form of securing the legs shall be taken to prevent a pile driver from overturning if a wheel breaks. Stirrups or other means shall be provided to prevent the rope from coming out of the top pulley or wheel. Hoisting ropes on pile drivers shall be made of galvanized steel.

Pile drivers shall not be erected in proximity to electric conductors. When electricity is used as power for piling rig, only armored cable conforming to BDS 901 and other relevant standards shall be used. The cable shall be thoroughly waterproofed.

3.4.3 Piles

Piles shall be prepared at a distance at least equal to twice the length of the longest pile, from the pile driver. Workers employed in the vicinity of pile drivers shall wear helmets conforming to BDS 1265. No steam or air shall be released until all workers are at a safe distance.

Piles shall be so slung that they do not swing or whip round. A hand rope shall be fastened to a pile hoisted to control its movement. Long piles and heavy sheet piling shall be secured against falling. While a pile is being guided into position in the leads, workers shall not put their hands or arms between the pile and the inside guide or on top of the pile. Inclined piles shall rest in a guide while driven.

The maximum length of wooden piles (ballies) shall be limited to 9 m. Ballies shall not be less than 50 mm in diameter at any place and shall spread to 75-200 mm in diameter at the top depending on the class of ballies. Each ballie shall be legibly and indelibly marked with information on the species of timber, suppliers name, class of ballie etc. Whenever required, butt ends of ballies shall be preserved with creosote-fuel oil mixture 50:50.

The driving end of a ballie post shall be provided with an iron ring or cap. When creosoted ballies are driven, adequate precautions, such as the provision of personal protective equipment and barrier creams, shall be taken to prevent injury from splashes of creosote.

3.4.4 Inspection and Tests

Pile driving equipment shall be inspected by an engineer at regular intervals not exceeding three months. A register shall be maintained at the site for recording the results of such inspection. Pile lines and pulley blocks shall be inspected by the foreman before the beginning of each shift for any excess wear or other defects.

Defective parts of pile drivers, such as sheaves, mechanism slings and hose shall be repaired by only competent technicians and duly inspected by foreman in-charge of the rig. The findings of such inspection shall be recorded in the register.

For every hoisting machine, chain, rig, hook, shackle, swivel and pulley block used in hoisting or suspending, the safe working loads shall be ascertained. Every hoisting machine and all gears shall be marked with the safe working loads and the conditions under which it is applicable.

Tests shall be performed in case of doubt and half of the tested load shall be taken as the safe working load. No part of any machine or any gear shall be loaded beyond the safe working load.

3.5 Construction of Walls

3.5.1 General

The height of wall constructed per day shall be restricted to ensure that the newly constructed wall does not collapse due to the lack of strength in the lower layers. Adequate number of expansion joints shall be provided in long walls to prevent crumpling.

3.5.2 Scaffold

Properly designed and constructed scaffolding built by competent workmen shall be provided during the construction of the walls to ensure the safety of workers. The scaffolding shall be of timber, metal or bamboo sections and the materials in scaffolding shall be inspected for soundness, strength, etc. at site by the Engineer-in-charge prior to erection of scaffolds. Steel scaffolds intended for use in normal building construction work shall conform to accepted BDS standards. Bamboo and timber scaffolds shall be properly tied to the junctions with coir ropes of sufficient strength or mechanical joints to ensure that joints do not give way due to the load of workmen and material. Joining the members of scaffolds only with nails shall be prohibited as they are likely to get loose under normal weathering conditions. The scaffold has to be checked after every 15 days in rainy season and 30 days in dry season. In the erection or maintenance of tall buildings, scaffoldings shall be of noncombustible material especially when the work is being done on any building in occupation. After initial construction of the scaffolding, frequent inspections of scaffolding shall be made by the Engineer-in-charge. The platforms, gangways and runways provided on the scaffoldings shall be of sufficient strength and width to ensure safe passage for the workmen working on the scaffolding. The joints provided in these gangways, platforms, etc. shall be such as to ensure a firm foot-hold to the workmen. Where necessary cross bars shall be provided to the full width of gangway or runway to facilitate safe walking.

The Engineer-in-charge shall ensure by frequent inspections that gangways of scaffolding have not become slippery due to spillage of material. Loose materials shall not be allowed to remain on the gangways. Where necessary, because of height or restricted width, hand-rails shall be provided on both sides. Workers shall not be allowed to work on the scaffolding during bad weather and high winds.

In the operations involved in the erection or maintenance of outside walls, fittings, etc. of tall buildings, it is desirable to use one or more net(s) for the safety of the workmen when the workmen are required to work on scaffoldings.

3.5.3 Ladders

Setting of Ladders: Rails of ladders shall extend at least 1m above the landing and shall be secured at the upper end. As an alternative, there shall be adequate handhold at landing or side guys with anchorage at the bottom.

To prevent slipping, a ladder shall be secured at the bottom end or held by a person at the time of use. A lean-to-ladder shall have a maximum angle of 75° with the horizontal. Ladders shall be provided with nonslip bases on slippery or sloping floors. Ladders used in strong wind shall be securely lashed in position.

A ladder shall neither be placed against window pane, sashes or such other fragile or easy yielding objects, nor in front of doors opening towards it. If set up in driveways, passageways or public walkways, it shall be protected by barricades. Ladders shall not be supported on any insecure base, e.g. scaffold, planking over trenches etc.

Use of Ladders: All ladders shall be constructed of sound material, and shall be capable of carrying the design loads. No ladder with a missing or defective rung, or supported on nails only, shall be used. A dropped ladder shall be inspected prior to reuse.

Ladders shall not be used as guys, braces or skids or in horizontal position as runways and catwalk. They shall not be generally overcrowded. Ladders shall not be spliced; when unavoidable, splicing shall be done only under the supervision of a foreman.

A user shall place his feet near the ends of the rungs rather than near the middle, and face the ladder when using it. Both the hands shall be used in climbing a ladder.

Leaning more than 300 mm from the side in order to reach another area from a single setting of the ladder shall not be allowed; the ladder shall be shifted to the required position.

All joints in the ladder shall be properly constructed. Where necessary, handrails shall be provided to the ladders. A brace shall be attached at the middle and supported from a non-yielding fixed object if a ladder shows tendency to spring. Excessive deflection of ladders shall be prevented by stiffeners.

Metal ladder shall not be used close to electrical equipment or circuits. They shall be marked with “CAUTION: DO NOT USE NEAR ELECTRICAL EQUIPMENT” signs. Overhead protection shall be provided for workers working under a ladder.

Wooden ladders shall be inspected at least once in 6 weeks for damage and deterioration. Close visual inspection is recommended in preference to load testing. This condition is particularly applicable to rope and bamboo ladders where fraying of ropes and damage to bamboo is likely to occur.

3.5.4 Opening in Walls

Before making an opening in an existing wall, adequate supports against the collapse or cracking of the wall portion above the opening or roof or adjoining walls shall be provided. Staging shall be of full length of the wall opening.

Wall opening barriers and screens shall be capable of withstanding the intended load. Every chute, wall opening or any other wall opening from which there is a vertical drop of more than 1200 mm shall be guarded by barriers.

The guard shall be removable, hinged or otherwise mounted. The guards shall be kept in position regardless of the use of the opening. In addition, a grab handle shall be provided on each side of the opening. The opening shall have a minimum 25 mm high sill.

3.5.5 Projection from Walls

Form work provided for horizontal projections out of the wall shall not be removed till walls, or other stabilizing construction, over the supporting edge of the projecting slabs providing protection against overturning are constructed.

3.5.6 Common Hazards During Walling

3.5.6.1 Lifting of Materials for Construction

Implements used for carrying materials to the top of scaffoldings shall be of adequate strength and shall not be overloaded during the work. Where workmen have to work below scaffoldings or ladder, overhead protection against the falling materials shall be provided. Care shall be taken in carrying large bars, rods, etc. during construction of the walls to prevent any damage to property or injury to workmen.

3.5.6.2 Haulage of Materials

In case of precast columns, steel beams, etc. proper precautions shall be taken to correctly handle, use and position them with temporary arrangement of guys till grouting of the base.

Manila or sisal rope shall not be used in rainy season for hoisting of heavy materials as they lose their strength with alternate wetting and drying.

3.5.6.3 Electrical Hazards

No scaffolding, ladder, working platform, gangway runs, etc. shall exist within 3 m from any uninsulated electric wire. The distance from high tension line for those features would be as per specifications of BPDB.

3.5.6.4 Fire Hazards

Gangways and the ground below the scaffolding shall be kept free from readily combustible materials including waste and dry vegetation at all times.

Where extensive use of blow torch or other flame is anticipated scaffoldings, gangways, etc. shall be constructed with fire resistant materials. A portable dry powder extinguisher of 3 kg capacity shall be kept handy.

3.5.6.5 Mechanical Hazards

Care shall be taken to see that no part of scaffolding or walls is struck by truck or heavy moving equipment and no material shall be dumped against them to prevent any damage. When such scaffoldings are in or near a public thoroughfare, sufficient warning lights and boards shall be provided on the scaffoldings to make them clearly visible to the public.

3.5.6.6 Fragile Materials

During glazing operations, adequate precautions shall be taken to ensure that the fragments of fragile materials do not cause any injury to workmen or general public in that area by way of providing covering to such material, side protection at work site, etc.

3.6 Construction of Floors

3.6.1 General

Platforms, catch ropes, nets etc. shall be provided during the construction of roofs. Precautions shall be taken to employ the correct technique of hoisting materials, to use hoists of sufficient strength for the quantity of stores to be hoisted, and to prevent overloading and overturning of hoists or buckets, etc.

Where, the floor of one storey is to be used for storage of materials for the construction of roof, it shall be ensured that the total load does not exceed the capacity of the floor.

3.6.2 Use of Sheets

It shall be ensured that joints in corrugated galvanized iron or asbestos cement sheets are kept secured in position and sheets do not slip. Walking on asbestos cement sheets shall not be allowed.

Tiles shall not be left loose on the roof.

Injury to passers-by due to breakage of glass or plastic sheets shall be prevented. During wet conditions, work on sloped roof shall not be allowed unless the foreman decides that the roof is not as slippery as to pose any risk. In slopes of more than 30° to the horizontal, ladders, waist-tie etc. shall be used.

3.6.3 Platforms

Working platform required according to the type of roof shall be provided. Additional precaution shall be taken to construct the platform with sound material secured and fixed, and checked from time to time throughout the period of construction.

3.6.4 Flat Roof

Formwork provided for flat concrete roof shall be designed and constructed for the anticipated loads.

During the construction of the roof, the formwork shall be frequently inspected for defects. Enough walking platforms shall be provided in the reinforcement area to facilitate safe walking to the concreting area. Loose wires and unprotected rod ends shall be avoided.

Formwork supporting cast-in-place reinforced and pre stressed concrete floors and roofs shall be adequately tied or braced together to withstand all loads until the new construction has attained the required strengths.

3.6.5 Openings and Holes

Every temporary floor opening shall either have railing of at least 900 mm height, or shall be constantly attended. Every floor hole shall be guarded by either a railing with toe board, or a hinged cover. Alternatively, the hole shall be constantly attended or protected by a removable railing.

Every stairway floor opening shall be guarded by a railing at least 900 mm high on the exposed sides except at entrance to stairway. Every ladder way floor opening or platform shall be guarded by a guard railing with toe board except at entrance to opening.

Every open sided floor or platform 1.2 m or more above adjacent floor or ground level shall be guarded by a railing on all open sides, except where there is entrance to ramp, stairway or fixed ladder. Such entrances shall be either guarded with a swinging gate, or so offset that a person is prevented from walking directly into the opening. The railing shall be accompanied by a toe board at least 200 mm high.

The above precautions shall also be taken near the open edges of floors and roofs. Requirements of Sections 1.7.3 and 1.7.4 shall also be met.

3.6.6 Skeleton Construction

Temporary flooring of skeleton construction shall be provided with tightly planked timber over timber supports to withstand all loads. The temporary flooring can also be made of metal sheet supported on timber or tubular steel frame. No end of the timber plank or metal sheet shall remain unsupported.

A temporary safety platform or tier shall be maintained within two stories or 6 m, whichever is less, below and directly under the portion where erection of steel or precast concrete member is required. Tiers shall extend 2.5 m beyond the edge of the work area.

3.7 Concrete Work**3.7.1 General**

All workmen involved in concrete work shall be provided with helmet and hand gloves, especially when concrete pumps, concrete trucks or concrete precast elements are used. Precast piles shall be lifted and driven by skilled workmen under the supervision of a foreman.

Temporary fencing, either with bamboo or C.I. sheet, shall be erected around heavy equipment delineating the danger zone. All centering and shuttering materials shall be kept stacked at site before and after use.

3.7.2 Prestressed Concrete

Operating, maintenance and replacement instructions of the supplier of the prestressing equipment shall be strictly adhered to in all relevant operations. During the jacking of any tension element, the anchor shall be kept turned up close to anchor plate.

Thread on bolts and nuts shall be frequently checked for deterioration; choked units shall be cleaned. Hydraulic jacks/rams, pulling-headers and other temporary anchoring devices shall be inspected before use. The prestressing jacks shall be periodically examined for wear and tear.

No person shall stand in line with the tensioning elements and jacking equipment during the tensioning operation. Also no one shall be directly over the jacking equipment when deflection is done. Workmen shall be prevented from working behind the jacks when the tensioning operation is in progress by putting signs, barriers, or protective shields.

3.7.3 Concrete Mixers

All gears, chains and rollers of mixer plants shall be guarded. If the mixer has a charging skip, the operator shall ensure that the workmen are at safe distance before the skip is lowered. Barriers shall be provided to prevent walking under the skip while it is being lowered.

All cables, clamps, hooks, wire ropes, gears, clutches, etc. of the mixer shall be checked and serviced once a week. A trial run of the mixer shall be made and defects rectified before using a mixer.

While cleaning inside of the mixing drums, the power shall be shut and fuses removed.

3.7.4 Concrete Truck and Buckets

A reasonably smooth traffic surface shall be provided for concrete trucks. If possible, a loop road shall be provided to allow continuous operation. An easy turnout shall be provided if a loop is not possible to provide. Workmen and moving plants shall not cross the truck lines as far as practicable.

Concrete buckets conveyed by crane or overhead cableway shall be suspended from deep throated hooks, preferably equipped with swivel and safety latch. Closing and locking of the exit door of the concrete bucket shall always be checked.

3.8 Formwork and Scaffold

3.8.1 Scaffold and Centering Materials

Scaffolds shall be made from strong bamboo poles, wooden posts, steel pipes or any other suitable materials. They shall be adequately tied to vertical members resting on firm floor. Strong ropes shall be used to tie up bamboo poles. In addition, cross-bracing with bamboo or wooden posts shall be provided along with ties or guys of steel wire or rod not less than 6 mm in diameter.

Wooden planks or steel sheets shall be placed across horizontal poles to provide suitable footrest and carry construction materials. The whole assembly shall be securely lashed together.

Deterioration of tying ropes and rotting planks shall be checked from time to time during the construction period and changed if required.

Scaffold shall be dismantled after use piece by piece. Holes in the wall shall be filled up with the same materials as that of the wall. Filled up holes shall have uniformity in texture and color with the surrounding surface. Crash striking shall not be allowed.

Triangular wooden wedges shall be put under the posts for easy dismantling of the members.

Timber planks or steel sheets covering several posts at a time shall be placed below the vertical or inclined posts.

Horizontal and inclined bracings shall be provided for posts higher than 3 m. Spans of beam bottoms shall be supported by posts at most 1 m apart if steel is used; instructions from the manufacturer/supplier shall be strictly followed. Spacing of props under beams shall consider the increased load, and shall be posted closer than those under the floor slab.

All scaffolding exceeding 20 m or six stories in height shall be constructed of noncombustible or fire-retardant materials. Centering layout shall be planned by the Engineer, bearing capacity of the soil and the effect of weather shall be considered in the planning.

All nails and similar projecting objects shall be removed or hammered down into the timber component of the centering and shuttering materials immediately after stripping off.

3.8.2 Formwork for Concrete

The formwork shall be strong and rigidly braced so as not to bulge or sag when concrete is placed.

It shall be constructed in such a way that it can be dismantled without causing damage to the concrete or disturbing the centering and shuttering of other elements.

Forms shall not be removed until the concrete has developed sufficient strength to support all predicted loads. Workers removing formwork shall wear helmets, gloves, heavy soled safety shoes and belts if adequate footing is not available above 2 m. In case of removal of roof shuttering, staging has to provide below the roof. While cutting any tying wires in tension, care shall be taken against backlash.

Bolts and nuts in vertical concrete walls shall be loosened and withdrawn before initial setting of concrete. The resulting hole shall be filled with rich mortar. The supports shall be dismantled in the order instructed by the Engineer.

All walls, columns, slabs etc. shall have plastic or mortar spacers (round for vertical structures and flat for slab) to be placed with the reinforcement to provide clear cover as per design. Top layers of slab reinforcement shall be held in position by steel chairs.

The formwork shall be water-tight especially for the roof slab. Bamboo matting shall be placed on planks or steel sheets to provide a rough surface after stripping of the formwork. Alternatively, ceilings shall be roughened up by chiseling immediately after stripping off the formwork.

Suitable camber shall be provided in the formwork for horizontal members. The camber for beams and slabs shall be 1 in 250, and for cantilevers, 1 in 50 of the projected length.

Half-seasoned soft-wood, laminated board or other smooth sheet shall be used for formwork for a Fair-faced finish. The upper surface of the formwork shall be covered with oiled soft building board or veneered particle board. Oiled paper or polythene sheet shall never be used.

The formwork made of materials liable to absorb water shall always be sprinkled with water before laying concrete. Water shall not be profusely used; the formwork shall be in a saturated surface dry condition.

All the forms shall be tested both individually and in combination before final use to detect any flaw or defect. Measures shall be taken immediately to remedy any faults, if detected, before the formwork is ready for use.

The frame and its joints shall be checked from time to time for the decay in ropes, bamboos, planks etc. The defective parts shall be replaced before the formwork is used.

3.8.3 Load Capacity

Scaffolds, formwork and components thereof shall be capable of supporting without failure, at least two times the maximum intended load. The following information shall be considered in designing the formwork:

- (a) Weight of wet concrete: 20 kN/m³.
- (b) Live load due to workmen and impact of ramming or vibrating: 1.5-4.0 kPa (light duty for carpenter and stone setters, medium duty for bricklayers and plasterers, heavy duty for stone masons).
- (c) Allowable bending stress (flexural tensile stress) in soft timbers: 8,000 kPa.

The sizes for formwork elements specified in Table 7.3.1 are applicable for spans of up to 5 m and height of up to 4 m. In case of longer span and height, formwork and support sizes shall be determined by calculating the load and approved by the engineer before use.

All formworks and scaffolds shall be strong, substantial and stable. All centering and props shall be adequately braced to ensure lateral stability against all construction and incidental loads, especially in the case of floor height more than 3.3 m.

The space under the scaffold or formwork shall not be used as a working or living space. The space shall not be used as a shelter or refuge during inclement weather or at any other time.

3.8.4 Bamboos

Good, sound and uniform bamboo shall be collected in sufficient quantities for providing scaffolding, propping, temporary staging, ramp etc. The bamboos shall be free from any defects, firmly tied to each other and joints made smooth. Joining members only with nails shall be prohibited.

Bamboos for vertical support shall not be less than 75 mm in diameter, and shall be straight as far as possible. Bamboos shall be used as vertical support for up to a height of 4 m, if horizontal bracings are provided at the centre. Splicing shall be avoided.

After stripping the formwork, the bamboo posts shall be cleaned and stacked vertically in shade protected from rain and sun. Defective or damaged bamboo posts shall be removed from the site.

3.8.5 Timber Posts

Timber posts shall be used in supporting formwork up to a height of 6 m. The posts shall not be less than 80 mm in diameter at any place and shall spread to at least 150 mm in diameter at the top.

The timber posts shall be supported on timber planks at the bottom. Either the bottom or the top of the posts shall be wedged with a piece of triangular wood peg for easy removal. Adequate horizontal and inclined braces shall be used for all timber centering.

All timber posts shall be carefully inspected before use and members with cracks and excessive knots and crookedness shall be discarded. The joints shall normally be made with bolts and nuts. No rusted or spoilt threaded bolts and nuts shall be used.

Table 7.3.1 Sizes of Timber and other Sections for Formwork

Types of Formwork	Members Size in mm
Flat sheetings for slab bottoms, columns and beam side	25 - 50
Beam bottoms	75 × 100 - 150 × 150
Vertical posts	75 × 100 - 150 × 150
Bamboo posts	Minimum 75 dia
Ballies	Diameter not less than 100 at mid-length and 80 at thin end
Joist and ledgers supporting sheetings of slab	50 × 100 - 75 × 200
Studs for supporting vertical wall sheetings	50 × 100 - 150 × 150
Columns yokes-horizontal cross pieces supporting vertical sheetings	50 × 100 - 100 × 100

3.8.6 Steel Centering

Steel centering shall be used for any height. In case of patented material, the instructions of the manufacturer regarding the load carrying capacities shall be followed.

Post to post supports shall be provided with wooden planks. When tubular steel and timber centering is to be used in combination, necessary precautions shall be taken to avoid any unequal settlement.

Tubular steel centering shall be thoroughly inspected before erection. Defective members shall be discarded and coupling pins aligned to frames. Adjustment screws shall be set to their approximate final adjustment after assembling the basic unit, and the unit shall be level and plumb.

The centering frames shall be braced to make a rigid and solid unit. Struts and diagonal braces shall be in proper position and secured. As erection progresses, all connecting devices shall be in place, and fastened for full stability of joints and units.

3.9 Erection Operations

3.9.1 Erection and Hoisting

The erection and striking off, especially of steel structural frame, shall be done by skilled workers. Built-up, swinging and suspended scaffolds shall also be erected by competent workers.

Care shall be taken to keep fire alarms, hydrants, cable tunnels etc. unobstructed during the construction of scaffolding and placement of ladders etc.

Anchors for guys or ties shall be checked for proper placement. The weight of concrete in which the anchors are embedded shall be checked for uplift and sliding. In a tall and heavy guy derrick, tension in guys shall be controlled by hand winches.

Enough number of bolts shall be used in connecting each piece using a minimum of two bolts in a pattern to ensure that the joint will not fail. All splice connections in columns, crane girders etc. shall be completely bolted or riveted or welded before erection as specified in the drawings.

The top flange of a truss, girder or long beam shall be temporarily reinforced with a flat bar on top of the member. On deep girders and large trusses, a safety bar running their full length shall be provided. The bar can be a single 16 mm diameter wire rope through vertical stiffeners of each member about one meter above the bottom flange and clamped at the ends with wire rope clamps. If holes cannot be provided, short eye bolts can be welded to the webs of the girder at intervals. The bolts shall be removed, and the surface chipped to leave it smooth after the erection is completed.

The first load lifted by a guy derrick shall be hanged at a low height for 10 minutes and the anchor inspected for any signs or indications of failure. No load shall be allowed to rest on wire ropes.

Ropes in operation shall not be touched. Each truss or deep girder loaded in a vehicle shall be tied back or braced together with other trusses or girders already loaded.

The ropes shall be chemically treated to resist dew and rotting. They shall not be tied on sharp edges of steel structures. They shall not be tied beyond the reach of safety belts complying to BDS 1359.

The proper size, number and spacing of wire rope clamps, depending on the diameter of the wire rope, shall be used. They shall be properly fixed and checked as soon as the rope has been stretched, particularly if new. The clamps shall be promptly tightened when expansion in rope is detected. Clamps and ropes shall be inspected frequently to be sure that they are secured at place.

3.9.2 Small Articles

Adequate supply of bolts, washers, rivets, pins etc. of required sizes shall be maintained at all times. Foot boxes on a guy derrick or climbing crane, shall be moved to the new working floor each time the rig is changed. On a mobile crane, the boxes shall be moved as soon as the crane is moved.

Bolt baskets or similar containers with handles shall be provided on floats or scaffolds where small material, such as bolts and drift pins are used. Small tools shall be gathered up and put away in tool boxes when not in use. Rivet heaters shall have safe containers or buckets for unused hot rivets.

Materials shall not be dumped overboard when a scaffold is to be moved.

3.9.3 Hoist Protection

A material hoist shall not be used to transport workers; temporary elevators shall be installed, if necessary. Proper protection by way of railing, footboard etc. shall be provided to the hoists.

Railing shall have a minimum height of 1 m while the toe board shall be at least 200 mm high.

Where erected on the outside of a building over 20 m or six stories in height, the hoist structure shall be built of noncombustible or fire retardant materials. Interlocking or any other safety device shall be installed at all stopping points of the hoists. The hoists shaft way shall be fenced in accordance with Sec 3.6.5.

No part of scaffolding or walls and openings shall be hit by crane, truck or heavy moving equipment.

3.9.4 Lifting Gear

Lifting gears shall be of good construction, sound material and adequate strength. Lifting gears must be tested and examined by a competent person. Chains, ropes and lifting tackle shall be thoroughly examined by a competent person every 6 months.

Special devices like cleats and hooks shall be used in erecting girders and other heavy structural members. These shall be shop-assembled, bolted, riveted or welded to the piece and left permanently in place after the work. A balance beam shall be used to lift laterally imbalanced pieces. Alternatively, a pair of bridle slings shall be used at safe lifting points.

Table of safe working loads shall be posted in the tackle store and in prominent positions. No chain, rope or lifting tackle shall be used for loads exceeding the safe working load. Wrought iron gear shall be effectively heat treated.

All lifting gear shall be obtained from reliable manufacturers. No home-made or improvised gear shall be used.

3.9.5 Cranes

All parts of a crane must be of good construction, free from defects, and properly maintained. Before the crane is used for the first time, it must be thoroughly examined and tested by a competent person.

Crane rails shall be installed and secured on firm ground. In tower cranes, the level difference between the two rails shall remain within the limits prescribed by the manufacturer.

The safe working load shall be clearly shown on the crane; no crane shall be loaded beyond this limit. Nobody shall be allowed to work on the wheel tracks within 6 m of a crane, or under crane where he might be struck, unless effective steps are taken to warn him.

Electrical wires within the site which can possibly touch the crane or any member being lifted shall be removed or made dead. Cranes shall not be operated in proximity to a live overhead power line.

If it becomes necessary to operate the crane crossing the safe clearance from power line, the overhead power lines shall be shut off.

Cranes shall be thoroughly examined, at least once in 9 months and the results entered in a register. The crane operator shall not violate the safe reach limit of the crane as specified by the manufacturer. Cranes shall not be operated at a speed which causes the boom to swing.

No person shall be lifted or transported by the crane on its hook or boom. Toe boards and limit stops shall be provided for wheel barrows on the loading and unloading platforms. Material shall be loaded securely on the platform with no projection.

Every crane driver or hoisting machine operator shall be competent to the satisfaction of the engineer and no person under the age of 21 years shall be allowed to operate any hoisting machine and scaffolding winch, or give signals to the operator. The crane driver shall have the full knowledge of controls, signals, loading, misuse, ground and emergency regulations.

When the bucket or other members being lifted are out of sight of the crane operator, a signalman shall be posted in clear view of the loading and unloading areas, and the crane operator. Standard hand signals shall be used in controlling the movements of the crane; both the operator and the signalman shall be familiar with the signals.

The crane operator shall respond to signals only from the assigned signalman but shall obey stop signal at any time from anybody both inside and outside the site.

If a gantry crane is used, a warning bell which sounds automatically during the movement of the crane shall be given to avoid accidents to workmen crossing or standing in the path of the moving loads.

3.9.6 Slings

Idle and loaded slings shall not be carried together on the crane hook. In multi-legged slings, each leg shall be evenly loaded. The slings shall be of sufficient length to avoid wide angle between the legs.

Chains shall not be joined by bolting or wiring links together. Shortening the chains by tying knots shall be prohibited. The chain shall be made free of twists and kinks. Proper eye splices shall be used to attach the chain hooks.

Chains with locked or stretched links and which do not move freely shall not be used. Ropes shall move freely in the sheave grooves. Sharp bends in wire ropes shall be avoided; pulley shall be used for these.

3.9.7 Inspection

Materials and joints in scaffolding shall be inspected from time to time both before and after erection for the soundness, strength, damage due to weathering etc. Inspections shall be made for spillage of material or liquids, loose material lying on the gangways, and proper access to the platform.

The scaffold shall be secured to the building at enough places; no ties shall be removed. Warning sign prohibiting the use of any defective or incomplete scaffold and working in bad weather and high wind shall be posted in a prominent place. Inspections shall be made for the observance of these requirements.

3.10 Electrification, Equipment and Operations

3.10.1 Wiring System

All temporary and permanent wiring systems shall be designed by an engineer. All temporary wiring shall be done by an electrician holding relevant license.

No scaffolding, ladder, working platform, gangway, runway, etc. shall be placed within 3 m of an un-insulated live electric wire. Overhead wires/cables shall be so laid that clearances as required by Sec 2.2.3.4 are maintained.

Protection shall be provided for all electrical wiring laid on floor which shall have to be crossed over. All flexible wiring connecting the electrical appliances shall preferably be enclosed in a flexible metal sheath. Frayed and bare wires shall not be used for any temporary or permanent electrical connection.

All electrical circuits, other than those required for illuminating the site at night, shall be switched off daily at the end of the work. The main switch board shall be located in an easily accessible and prominent place. No clothing or stores shall be kept near it. One CO₂ extinguisher (3 to 4.5 kg), or one 5-kg dry powder extinguisher, shall be provided near the switch board.

3.10.2 Guarding of Cables

All cables and signal cords shall be guarded wherever such cables and cords pass through or cross working spaces. Location of underground cables, if any, as well as overhead cables, shall be identified and the scaffolds, hoists etc. shall be installed after providing proper guards to such cables.

Respective agencies shall be consulted for the proper method of providing protection to such cables, distance to be maintained to avoid all hazards etc. Cables, especially underground, and their routes shall be marked for future reference and use.

3.10.3 Lifts

Lifts shall be installed as per instruction of the manufacturer and under proper guidance. If necessary, guards shall be stationed at the installation site. Building materials shall preferably not be carried in a lift.

Entry to the empty lift well shall be blocked; the blockade shall be capable of withstanding bumping of an individual against it. Notices/signs shall be displayed in the lift lobby when the lift is not in operation.

3.10.4 Construction Machinery

Construction machinery shall conform to standards specified in the specification of works, or determined as required on site and approved by the engineer. They shall be in running condition without any defect.

The machinery shall be operated by competent operators only. The machinery will be checked thoroughly for any defect periodically, as well as each day before use.

Every moving part of or prime mover, and every part of electric generators, motors and rotary converters shall be securely fenced. Fencing shall be of substantial construction, maintained in efficient working order, and kept in position when the machine is in motion.

If machines need to be examined, oiled or adjusted while in motion, it shall be approached by certified mechanics only. Approach to unfenced machinery is allowed only when examination, lubrication etc. cannot be done with machinery at rest, or when machinery cannot be stopped without serious interference with the ongoing process.

Exhaust of petrol or diesel powered air compressors, hoists, derricks, pumps and all such machinery shall be well away from combustible materials. Exhausts opening outside the building shall have a minimum clearance of 200 mm from combustible materials. All sources of ignition like naked flame shall be banned near petroleum- fired equipment.

3.10.5 Heating of Bitumen and Tar

3.10.5.1 Bitumen and Tar Vessels

Tanks, vats, kettles, pots, drums and other vessels for heating tar, bitumen and other bituminous materials shall be made resistant to damage due to transportation, excessive heating etc. All such vessels shall be capable of holding a full load without danger of collapse, bursting or distortion. They shall be provided with a close-fitting cover suitable for smothering a fire in the vessel preventing spillage or protecting the bituminous material from rain.

Buckets for hot bitumen, bituminous material or tar shall have the bail or handle firmly secured, and a second handle near the bottom for tipping. Bitumen or tar boilers shall be mounted on wheels for easy transportation or towing, and provided with hand pumps for spraying purposes.

Heated vessels shall not be left unattended. Only vessels using electricity for heating shall be used inside buildings. Tar boilers shall never be used on a roof constructed of combustible materials.

Bituminous material shall not be thrown into the hot vessels. Vessels shall be kept closed when not in use. Containers shall not be filled to the brim with hot bitumen or tar. Enough space shall be left in vessels for expansion of heated binder.

The vessel shall be leak-proof, and provided with controllable outlets. The buckets and cans in which the hot material is carried shall be checked for any defect before use.

3.10.5.2 Heating of Bitumen and Tar

Gas and oil-fired bitumen and tar kettles or pots shall be equipped with burners, regulators, and safety devices. Heating appliances for vessels shall distribute the heat uniformly over the heating surface. If bituminous mixtures have mineral aggregate filler, some means for stirring shall be provided.

Vessels filled with bituminous materials shall be kept at a distance from combustible materials. When vessels are used in confined spaces, the gases, fumes and smoke generated shall be removed by exhaust or forced ventilation.

No naked light shall be used near heated boilers. If a burner stops burning, the fuel supply shall be cut-off immediately and the heating tube shall be thoroughly blown out by the fan.

Cutbacks shall not be heated over an open flame unless a water jacket is used. While they are being heated, the vessel shall be kept open. Blow-lamps or similar devices shall be used for warming pipes instead of burning rags. Bitumen and tar shall not be heated beyond the temperature recommended by the manufacturer of the product.

3.10.5.3 Other Precautions

Indicator gauges shall be used to ascertain level and temperature of the material in the boiler; nobody shall be allowed to peep into the boiler to ascertain the level. In small plants, dipstick shall be used to gauge the levels in the boiling pot.

Bitumen and tar shall be kept dry. Boiler shall either have a device that prevents foam from reaching the burners, or anti-foaming agents shall be used to control foaming. The heating shall be at low temperature till the water entrapped, if any, is completely evaporated. Any water present in the boiler shall also be drained out before using it.

Bitumen or tar spilled around boilers shall be promptly cleaned up. When tanks are cleaned by steam, building-up of pressure shall be prevented. No inspection shall be made while the boiler is under use, or is pressurized.

While discharging heated binder from the boiler, workers shall not stand opposite to the jet. The container shall be handled only after closing the valve. Bitumen and tar shall be handled in a way as not to spill.

Mops and other applicators covered with bituminous materials shall not be stored inside buildings.

3.10.6 Flame Cutting and Welding

For all arc welding work, either a helmet or a hand-held face shield conforming to BDS 1360 shall be used. See also Sec 3.2.1.

All welding and flame-cutting operations shall be performed in protected areas; closed spaces shall be properly ventilated. Suitable protection against the rays of the electric arc shall be provided where arc welding operations might be viewed within normal range by persons other than the welding operators and inspectors.

When working on aluminum structures, or close to other welders, protection for the back of the head shall be arranged. When slag is being removed from weld by clipping, the eyes shall be protected by goggles conforming to BDS 1360.

Leather gauntlet gloves with canvas or leather cuffs, shall be worn by welders. Any visible foam near the arc shall be rapidly dispersed. Where argon or carbon dioxide is being used as the shielding gas, particularly in confined spaces, breathing apparatus of the airline type shall be worn.

Gas cylinders shall be kept in the upright position, and conveyed in trolleys. While being carried by cranes, the gas cylinders shall be put in cages. The cylinder shall be marked 'full' or 'empty' as the case may be.

Gas cylinders shall be stored away from open flames and other sources of fire. Oxygen cylinders shall not be stored near oil, grease, sources of gas and similar combustible materials.

When the cylinders are in use, cylinder valve key or wrench shall be placed in position. Cylinder valve shall be closed before a cylinder is moved, when the torches are being replaced or welding is stopped for some reason. The cylinder valve and connection shall not be lubricated.

A 5 Kg CO₂ or Dry Chemical Powder (DCP) type fire extinguisher must be kept where gas cutting and welding works are done. Acetylene cylinder which has been subject to heat must be kept completely submerged in water at least for 12 hours before further use.

Gas cutting and welding torches shall be lighted by special lighters, not with matches. The cables from welding equipment shall not be run over by traffic. Double earthing shall be provided to the welding machines.

If welding is to be done near combustible materials, suitable blanket shall be provided and fire extinguishers kept nearby. Welding shall not be done in areas where flammable liquids and gases are stored.

Gas lines and compressed air lines shall be marked differently by suitable color codes. Facilities shall be provided in approved closed containers for housing the necessary vision, respiratory and protective equipment required in welding operations.

3.10.7 Riveting Operation

Rivets shall be carefully handled to prevent accidental fall; wooden bottom shall be provided in rivet catchers. Chains shall not be used in riveting dollies; leather, canvas or rope sling shall be used.

Snap and plunger shall be prevented from dropping out of place by securing the pneumatic riveting hammer. Nozzle of the hammer shall be inspected from time to time. Torn or worn wire attachment shall be renewed. Water shall be kept ready for putting out fire during riveting operations.

Snap and plunger shall be prevented from dropping out of place by securing the pneumatic riveting hammer. Nozzle of the hammer shall be inspected from time to time. Torn or worn wire attachment shall be renewed. Water shall be kept ready for putting out fire during riveting operations.

3.11 Construction Hazards

3.11.1 General

Implements used for carrying materials to the top of scaffolding shall be of adequate strength and shall not be overloaded during the work. Overhead protection against falling materials shall be provided under scaffoldings and ladders. Care shall be taken in carrying long and heavy bars, rods, angles and other such materials.

Precautions shall be taken to correctly handle, use and position precast RC columns, piles, steel beams, joists, angles and other heavy elements. Temporary supports with guys and props shall be provided in handling heavy elements till the member is properly and permanently secured in position. Manila or Sisal rope shall not be used in rainy season for hoisting heavy materials.

People suffering from asthma, chronic bronchitis, pulmonary fibrosis, or pneumoconiosis shall be screened out from being employed in works involving the use of paints, varnishes, plastic foam, rubber, adhesives, etc. Those having impaired lung function, hay fever, eczema, dermatitis etc. shall also be advised to avoid such work.

All construction sites shall have sufficient general and local ventilation unless otherwise required.

Adequate number of Absorptive respirators shall be provided to sites with inhalation hazard. Full breath apparatus shall be used for works of limited period in dangerous situations.

The workers shall be made aware of personal hygiene. Regular health checkup shall be arranged for works requiring high physical fitness for prolonged period.

3.11.2 Fire Hazards

Gangways and the ground below the scaffolding shall be kept free from readily combustible materials including waste, debris and any vegetation at all times.

Scaffoldings, gangways, etc. shall be constructed with fire resistant materials when blow torch or other equipment producing flame is extensively used near it. A portable dry powder extinguisher of 3 kg capacity shall be kept near all flame producing equipment. Sections 2.1.3, 2.2.4 and 2.2.5.3 of Chapter 2 of this Part shall also be followed in addition to the following requirements.

3.11.2.1 Fire Protection

Fire extinguishers, preferably of water type, shall be placed at strategic points.

Extinguishers shall always be placed in cranes, hoists, compressors and similar places. Where electrical equipment is used, CO₂ or dry powder extinguishers shall be provided.

In addition to fire extinguishers, other fire extinguishing equipment, e.g. sprinklers and hydrants shall also be provided and conveniently located both within the building under construction and at the building site. All extinguishers shall be maintained in a usable condition at all times in accordance to the instructions of the manufacturer.

All workmen and supervisory staff shall be clearly briefed on the use of fire extinguishers provided at the construction site. Free access shall be provided and maintained at all times to all firefighting equipment including fire hose, extinguishers, sprinkler valves and hydrants.

Where the project itself requires the installation of fixed firefighting equipment, such as hydrants, stand pipes, sprinklers and underground water mains or other suitable arrangements for the provision of water, it shall be installed and made available for permanent use as soon as possible, in no case later than the scheduled time.

A permanent hydrant system shall be made available before the building has reached the height of 20 m. This shall be extended with every increase in the number of floors, and securely capped at the top. Top hose outlets shall be at all times not more than one floor below the floor under construction. All construction sites with a fire risk shall have at least two exits.

Temporary stand pipes with required pumps shall be provided in place of permanent systems if they are designed to furnish 400 liters of water per minute at 450 kPa pressure with a standpipe size of not less than 100 mm.

A metal box of substantial size preferably to be kept open, shall be provided and maintained near each hose outlet. It shall contain adequate length of hose fitted with 12 or 20 mm nozzle to reach all parts of the floor.

Free access from the street to such stand pipe shall be maintained at all times. Materials shall not be stored within 1.5 m of any fire hydrant or in the roadway between such hydrant and the centre line of the street.

Contact shall be established and maintained with the local fire authority during construction of all buildings above 20 m in height and buildings of special occupancies like educational, assembly, institutional, industrial, storage, hazardous and mixed occupancies having areas in excess of 500 m² on each floor.

Telephone or other means of inter-communication system within the site shall be provided during the construction of all buildings over 20 m in height or buildings with a plinth area in excess of 1000 m².

All waste, such as scrap timber, wood shavings, sawdust, paper, packing materials and oily substance, particularly in or near vertical shaft openings like stairways, lift shaft etc. shall be collected and disposed of safely at the end of each day's work.

An independent water storage facility shall be provided before the commencement of construction operations for fire-fighting purposes. The tank shall be kept filled up at all times. Sec 2.2.5 shall also be followed.

3.11.2.2 Flammable Materials and Explosives

Highly flammable materials, such as gasoline, oil, paints etc. shall be stored in approved containers. Storage of large quantities shall not be allowed unless stored in separate compartments or enclosures of noncombustible construction.

Where cellulose or other highly flammable paint is sprayed, flame-proof exhaust ventilation equipment shall be provided. Smoking shall be strictly controlled where highly flammable liquids are used.

Explosives like detonators, gunpowder etc. shall be stored in conformity with relevant regulations for storage and handling of explosives. Combustible materials shall not be stored on any floor under construction until all combustible form works are removed from the tier immediately above.

3.11.2.3 Temporary Heating

When temporary heating is used, all regulations as to the maximum temperature, distance from combustible materials, spark arrestors, removal of noxious gases and other similar requirements shall be fully observed. Temporary enclosure shall be provided where the source of temporary heat includes open-flame devices.

3.11.2.4 Steam Boiler

All temporary or permanent high pressure steam boilers shall be operated only by licensed operators. Where located within a building or within 3 meters of combustible materials or electric power lines, all such boilers shall be enclosed with approved noncombustible covers. Safety valves shall be adjusted to exactly 70 kPa in excess of working pressure. Two Dry Chemical Powder (DCP) type fire extinguishers of 5 kg capacity each shall be kept at easily accessible locations.

3.11.2.5 House Keeping

Rubbish, trash, nuts, bolts and small tools shall not be allowed to accumulate on the site and shall be removed as soon as conditions warrant. Combustible rubbish shall be removed daily. Rubbish shall not be burnt on the premises or in the immediate vicinity. The entire premises and area adjoining and around the construction site shall be kept in a safe and sanitary condition.

3.11.2.6 Fire Exits

All construction sites with a fire-risk shall have at least two clearly marked fire exits.

Other means of escape as required by various sections of this Code shall be provided in a construction site. Fire exits shall be easily operable; stores, packing materials or rubbish shall not obstruct the exit.

Fire walls and exit stairways required for a building shall be given priorities in construction schedule. Where fire doors, with or without automatic closing devices, are to be set in the building, they shall be hung as soon as practicable, and before fire risk is increased by way of greater use of combustible material.

3.11.3 Health Hazards

3.11.3.1 Emission

Precautionary measures shall be taken against the emission of dust, small particles, toxic gases and other harmful substances in quantities hazardous to health. Such measures shall include local ventilation, use of protective devices, medical check-up etc. Exhaust ventilation shall be employed in enclosed spaces.

3.11.3.2 Clothing

Clothes worn by the workmen shall not be of such nature and materials as to increase the chances of inflicting injuries to themselves or others. Wearing of loose garments shall be strictly avoided.

Workmen using naked flames (such as in welding) shall not wear clothing of synthetic fibre or similar materials which increases the risk of fire hazards.

3.11.3.3 Removal of Dust

Spread of dust, sand blasts and other harmful materials and chemical agents shall be controlled at or near the source to prevent overspill to adjoining premises or streets.

Proper gear and protection as required by regulations shall be provided to the workmen.

Proper methods of handling and transportation shall be followed. Places prone to generate dust shall be frequently cleaned. Machinery and plants shall be designed for easy cleaning.

3.11.3.4 First Aid and Ambulance

A copy of all pertinent regulations and notices concerning accidents, injury and first aid shall be prominently displayed at the work site.

A first aid box or cupboard shall be provided for every 150 workmen and be accessible. The provision shall also include a stretcher and cot with accessories for every 300 workmen.

In case of a site where more than 600 workmen are employed at any one time, or in which more than 300 workmen are employed at any one time and is 15 km from the nearest health service facility, provision of an ambulance shall be made.

3.11.4 Skin Hazard

Workmen engaged in works which may splash liquid or other materials liable to injure the skin shall have enough protective clothing to cover the body and limbs.

Whenever epoxy resins are mixed indoor, the place shall be adequately ventilated. Damaged protective gears shall not be used, and shall be replaced. Containers of hazardous chemicals shall be kept in a clearly marked-off area of the work space.

Spillage on and contamination of tools, equipment, or the outside of the containers shall be avoided. If spillage or contamination occurs, the affected area shall be cleaned up immediately.

Contaminated skin/part of the body shall be washed immediately with warm soapy water. Proper barrier creams shall be used. All contamination on part of the body shall be regularly and efficiently removed during breaks and after finishing time.

3.11.5 Noise Hazard

Noise shall be controlled, if possible, by soundproof shields, baffles or absorbent lined booths being fitted near or around the source. Other general methods of control shall include silencing of machine exhaust, choice of quiet machines etc.

Protective measures shall be taken if the continuous noise level at the construction site exceeds 90 dB. For levels up to 110 dB, properly fitted ear plugs of plastic, rubber or glass wool shall be provided. For levels up to 120 dB, ear muffs shall be used; for levels exceeding 120 dB, noise protection helmets shall be provided.

All noise control equipment shall be regularly inspected and maintained by adequately trained personnel. Care shall be taken to prevent noise becoming a nuisance to neighbouring property.

Other precautions as specified in Chapter 3 of Part 8 shall also apply.

3.12 Additional Safety Requirements for Erection of Concrete Framed Structures (High Rise Buildings)

Workmen working in any position where there is a falling hazard shall wear safety belts or other adequate protection shall be provided.

3.12.1 Handling of Plant

3.12.1.1 Mixers

All gears, chains and rollers of mixers shall be properly guarded. If the mixer has a charging skip the operator shall ensure that the workmen are out of danger before the skip is lowered. Railings shall be provided on the ground to prevent anyone walking under the skip while it is being lowered.

All cables, clamps, hooks, wire ropes, gears and clutches, etc. of the mixer, shall be checked and cleaned, oiled and greased, and serviced once a week. A trial run of the mixer shall be made and defects shall be removed before operating a mixer.

When workmen are cleaning the inside of the drums, operating power of the mixer shall be locked in the off position and all fuses shall be removed and a suitable notice hung at the place.

3.12.1.2 Cranes

See Sec 3.9.5 of this Chapter.

3.12.1.3 Trucks

When trucks are being used on the site, traffic problems shall be taken care of. A reasonably smooth traffic surface shall be provided. If practicable, a loop road shall be provided to permit continuous operation of vehicles and to eliminate their backing. If a continuous loop is not possible, a turnout shall be provided. Backing operations shall be controlled by a signaller positioned so as to have a clear view of the area behind the truck and to be clearly visible to the truck driver. Movement of workmen and plant shall be routed to avoid crossing, as much as possible, the truck lanes.

3.12.2 Formwork

The Formwork shall conform to the shape, lines and dimensions as shown on the plans, and be so constructed as to remain sufficiently rigid during the placing and compacting of the concrete, and shall be sufficiently tight to prevent loss of liquid from the concrete.

Formwork shall be designed after taking into consideration spans, setting temperature of concrete, dead load and working load to be supported and safety factor for the materials used for formwork.

All timber formwork shall be carefully inspected before use and members having cracks and excessive knots shall be discarded.

As timber centering usually takes an initial set when vertical load is applied, the design of this centering shall make allowance for this factor.

The vertical supports shall be adequately braced or otherwise secured in position that these do not fall when the load gets released or the supports are accidentally hit.

Tubular steel centering shall be used in accordance with the manufacturer's instructions. When tubular steel and timber centering is to be used in combination necessary precautions shall be taken to avoid any unequal settlement under load.

A thorough inspection of tubular steel centering is necessary before its erection and members showing evidence of excessive resting, kinks, dents or damaged welds shall be discarded. Buckled or broken members shall be replaced. Care shall also be taken that locking devices are in good working order and that coupling pins are effectively aligned to frames.

After assembling the basic unit, adjustment screws shall be set to their approximate final adjustment and the unit shall be level and plumb so that when additional frames are installed the tower shall be in level and plumb. The centering frames shall be tied together with sufficient braces to make a rigid and solid unit. It shall be ensured that struts and diagonals braces are in proper position and are secured so that frames develop full load carrying capacity. As erection progresses, all connecting devices shall be in place and shall be fastened for full stability of joints and units.

In case of timber posts, vertical joints shall be properly designed. The connections shall normally be with bolts and nuts. Use of rusted or spoiled threaded bolts and nuts shall be avoided.

Unless the timber centering is supported by a manufacturer's certificate about the loads it can stand, centering shall be designed by a competent engineer.

Centering layout shall be made by a qualified engineer and shall be strictly followed. The bearing capacity of the soil shall be kept in view for every centering job. The effect of weather conditions shall be considered as dry clay may become very plastic after a rainfall and show marked decrease in its bearing capacity.

Sills under the supports shall be set on firm soil or other suitable material in a pattern which assures adequate stability for all props. Care shall be taken not to disturb the soil under the supports.

Adequate drainage shall be provided to drain away water coming due to rains, washing of forms or during the curing of the concrete to avoid softening of the supporting soil strata.

All centering shall be finally, inspected to ensure that :

- (a) Footings or sills under every post of the centering are sound.
- (b) All lower adjustment screws or wedges are snug against the legs of the panels.
- (c) All upper adjustment screws or heads of jacks are in full contact with the formwork.
- (d) Panels are plumb in both directions.
- (e) All cross braces are in place and locking devices are in closed and secure position.
- (f) In case of balconies, the props shall be adequate to transfer the load to the supporting point.

During pouring of the concrete, the centering shall be constantly inspected and strengthened, if required, wedges below the vertical supports tightened and adjustment screws properly adjusted as necessary. Adequate protection of centering shall be secured from moving vehicles or swinging loads.

Forms shall not be removed earlier than as laid down in the specifications and until it is certain that the concrete has developed sufficient strength to support itself and all loads that will be imposed on it. Only workmen actually engaged in removing the formwork shall be allowed in the area during these operations. Those engaged in removing the formwork shall wear helmets, gloves and heavy soled shoes and approved safety belts if adequate footing is not provided above 2 m level. While cutting any tying wires in tension, care shall be taken to prevent backlash which might hit a workman.

The particular order in which the supports are to be dismantled shall be followed according to the instructions of the site engineer.

3.12.3 Ramps and Gangways

Ramps and gangways shall be of adequate strength and evenly supported. They shall either have a sufficiently flat slope or shall have cleats fixed to the surface to prevent slipping of workmen.

Ramps and gangways shall be kept free from grease, mud, snow or other slipping hazards or, other obstructions leading to tripping and accidental fall of a workman.

Ramps and gangways meant for transporting materials shall have even surface and be of sufficient width and provided with skirt boards on open sides.

3.12.4 Materials Hoists

The hoist shall be erected on a firm base, adequately supported and secured. All materials supporting the hoist shall be appropriately designed and strong enough for the work intended and free from defects.

The size of the drum shall match the size of the rope. Not less than two full turns of rope shall remain on the drum at all times. Ropes shall be securely attached to the drum.

All ropes, chains and other lifting gear shall be properly made of sound materials, free from defects and strong enough for the work intended. They shall be examined by a competent person who shall clearly certify the safe working load on each item and the system.

Hoist ways shall be protected by a substantial enclosure at ground level, at all access points and wherever persons may be struck by any moving part.

Gates at access points shall be at least 2 m high wherever possible. Gates shall be kept closed at all times except when required open for immediate movement of materials at that landing place.

All gates shall be fitted with electronic or mechanical interlocks to prevent movement of the hoist in the event of a gate being opened.

Winches used for hoists shall be so constructed that a brake is applied when the control lever or switch is not held in the operating position (dead-man's handle).

The hoist tower shall be tied to a building or structure at every floor level or at least every 3 m. The height of the tower shall not exceed 6 m after the last tie or a lesser height as recommended by the manufacturer. All ties on a hoist tower shall be secured using right angled couples.

The hoist shall be capable of being operated only from one position at a time. It shall not be operated from the cage. The operator shall have a clear view of all levels or, if he has not, a clear and distinct system of signaling shall be employed.

All hoist platforms shall be fitted with guards and gates to a height of at least 1 m, to prevent materials rolling/falling from the platform.

Where materials extend over the height of the platform guards, a frame shall be fitted and the materials secured to it during hoisting/lowering. (Care shall be taken to ensure that neither the frame nor materials interfere or touch any part of the hoisting mechanism.)

The platform of a goods hoist shall carry a notice stating :

- (a) The safe working load; and
- (b) That passengers shall not ride on the hoist.

All hoist operators shall be adequately trained and competent, and shall be responsible for ensuring that the hoist is not overloaded or otherwise misused.

All hoists shall be tested and thoroughly examined by a competent person before use on a site, after substantial alteration, modification or repair of hoists, and at least every 6 months.

Every hoist shall be inspected at least once each week by a competent person and a record of these inspections kept.

3.12.5 Prestressed Concrete

In pre-stressing operations, operating, maintenance and replacement instructions of the supplier of the equipment shall be strictly adhered to.

Extreme caution shall be exercised in all operations involving the use of stressing equipment as wires/strands under high tensile stresses become a lethal weapon.

During the jacking operation of any tensioning element(s) the anchor shall be kept turned up close to anchor plate, wherever possible, to avoid serious damage if a hydraulic line fails.

Pulling-headers, bolts and hydraulic jacks/rams shall be inspected for signs of deformation and failure. Threads on bolts and nuts shall be frequently inspected for diminishing cross section.

Choked units shall be carefully cleaned.

Care shall be taken that no one stands in line with the tensioning elements and jacking equipment during the tensioning operations and that no one is directly over the jacking equipment when deflection is being done. Signs and barriers shall be provided to prevent workmen from working behind the jacks when the stressing operation is in progress.

Necessary shields shall be put up immediately behind the prestressing jacks during stressing operations.

Wedges and other temporary anchoring devices shall be inspected before use.

The pre-stressing jacks shall be periodically examined for wear and tear.

3.12.6 Erection of Prefabricated Members

A spreader beam shall be used wherever possible so that the cable can be as perpendicular to the members being lifted as practical. The angle between the cable and the members to be lifted shall not be less than 60°.

The lifting wires shall be tested for double the load to be handled at least once in six months. The guy line shall be of adequate strength to perform its function of controlling the movement of members being lifted,

Temporary scaffolding of adequate strength shall be used to support precast members at predetermined supporting points while lifting and placing them in position and connecting them to other members.

After erection of the member, it shall be guyed and braced to prevent it from being tipped or dislodged by accidental impact when setting the next member.

Precast concrete units shall be handled at specific picking points and with specific devices. Girders and beams shall be braced during transportation and handled in such a way as to keep the members upright.

Methods of assembly and erection specified by the designer shall be strictly adhered to at site.

Immediately on erecting any unit in position, temporary connections or supports as specified shall be provided before releasing the lifting equipment. The permanent structural connections shall be established at the earliest opportunity.

3.12.7 Heated Concrete

When heaters are being used to heat aggregates and other materials and to maintain proper curing temperatures, the heaters shall be frequently checked for functioning and precautions shall be taken to avoid hazards in using coal, liquid, gas or any other fuel.

3.12.8 Structural Connections

When reliance is placed on bond between precast and in-situ concrete the contact surface of the precast units shall be suitably prepared in accordance with the specifications.

The packing of joints shall be carried out in accordance with the assembly instructions.

Leveling devices, such as wedges and nuts which have no load bearing function in the completed structure shall be released or removed as necessary prior to integrating the joints.

If it becomes necessary to use electric power for in-situ work, the same shall be stepped down to a safe level as far as possible.

3.13 Miscellaneous

3.13.1 Stair, Ramp and Gangway

Buildings higher than two stories shall have at least one stair in usable condition at all times. This shall be extended upward with each completed floor. Till the permanent handrails are provided, temporary provisions like ropes, bamboo poles etc. shall be provided on stair.

Suitable precautions by way of support, formworks, etc. shall be taken to prevent any collapse of the stair during its construction. No person shall be allowed to use such stair until they are tested by the engineer and found fit for usage.

Where a building has been constructed to a height greater than 14 m or four stories, or where an existing building higher than 14 m is altered, at least one temporary lighted stairway shall be provided unless one or more of the permanent stairways are erected as the construction progresses.

Ramps and gangways shall be of adequate strength and evenly supported. They shall either have a sufficiently flat slope (maximum 15° to horizontal), or shall have cleats fixed to the surface. They shall be kept free from slipping hazards and obstructions.

Ramps for transporting materials shall have even surfaces, be of sufficient width and provided with 200 mm high toe boards on open sides.

Requirements as set in Sec 3.11.2 of this Chapter shall also be observed.

3.13.2 Fragile Fixture

It shall be ensured that sufficient number of workmen and equipment are provided to carry the fragile fixtures in the site like sanitary fittings, glass sheets, etc. Fragile fixtures shall be stored in a safe place away from the normal circulation path of people, equipment and vehicle (see Sec 2.2 Chapter 2 of this Part for additional requirements of safe handling of fragile fixtures and materials).

3.13.3 Hand Tools

Correct tools in good condition shall be used for each type of job. All tools, particularly at heights, shall be stowed. Wooden handles shall be made of good quality straight-grained materials. Hand tools shall be issued through a tool room where they are stored safely and inspected periodically by competent people.

Hammer head shall be securely attached to the shaft. The head shall be in good condition and the face free from chipped edges and not rounded from wear. The hammer shall not be used if the shaft is split, broken or loose.

Set spanners with splayed jaws, or box spanners showing signs of splitting shall not be used. A fixed spanner of correct size shall be preferred over an adjustable spanner. A tube shall not be used to obtain extra leverage; end of a spanner shall never be hammered. A spanner shall not be used as a hammer, nor as a wedge.

A chisel with a mushroom head shall never be used. A chisel shall be used to cut in a direction away from the body. Screwdriver handle shall be properly secured. A screwdriver shall never be used as a chisel.

Use of files with an exposed tang shall be avoided. Files shall not be used as levers or toggle-bar.

When a knife is used to cut greasy materials, the handle shall be such that it offers a firm grip and a shield shall be fitted between the handle and the blade. The cut shall always be made away from the body.

3.13.4 Steel Structure

Riding on trusses while hauling them to their final position, shall not be allowed. The hauling ropes shall be load tested before use.

Once in position, the trusses shall be kept secured with adequate temporary measures till the final fixing is carried out. Standard safety belts conforming to BDS 1359 shall be used while fixing purlins on the trusses.

In steel construction, the entire tier of iron or steel beams shall be planked over, with the exception of necessary hoist ways and permanent openings. Steelwork shall not advance more than six floors ahead of the permanent floor construction.

The proposed erection scheme of a steel work shall be analyzed and checked for safety measures undertaken; the scheme shall cover safety aspects at all stages.

3.13.5 Finish Works

3.13.5.1 Painting

The quantity of paint and thinner required only for the day's work shall be issued from the store. All unused containers of paint and thinner shall be closed with tight-fitting lids, and kept at a safe place away from the work site.

Metal receptacles with pedal operated metal lids shall be kept at the work site for depositing used cotton rags and waste. The contents of such receptacles shall be disposed of daily at a safe place, preferably by burning under proper supervision.

All containers of paint shall be deposited in the paint store after use. Used paint brushes shall be cleaned and deposited in the store. A 5 kg dry powder fire extinguisher shall be kept near the paint store (see Sec 2.2.16 Chapter 2 of this Part).

Adequate ventilation to prevent the accumulation of flammable vapour to hazardous level of concentration shall be provided in all areas where painting is done. When painting is done in confined spaces where flammable or explosive vapour may develop, required heat and power shall only be provided through covered ducts remote from the likely source of flame.

Sources of ignition, such as open flame and exposed heating elements, shall not be permitted in areas or rooms where spray painting is done, nor shall smoking be allowed there.

3.13.5.2 Polishing

Extra care shall be taken while handling polish consisting of acid and other chemical ingredients. Only the quantity of polish required for the day's work shall be kept at the work spot.

All containers of polish shall be kept closed with tight fitting lids in a safe place.

Protective clothing, gloves, respiratory equipment, etc. shall be provided to the workmen applying polishes. See also Sec 2.2.4 Chapter 2 of this Part.

3.13.5.3 Pavements

Pavement risers shall not be higher than 225 mm. All undulating surfaces shall be smoothed. At least a 1 m x 0.5 m area of the pavement adjacent to a vehicular road crossing shall have a checkered surface preferably of a texture and colour different from those of the surrounding surface.

3.13.5.4 Terracing

Protective clothing, gloves and shoes shall be used in terracing work, especially while handling lime and other ingredients. Lime and mortar stuck on the body shall be thoroughly cleaned. Other requirements for handling lime are specified in Sec 2.2.1.2 Chapter 2 of this Part.

PART VII
Chapter 4
Demolition Work

4.1 Preliminary Procedure

4.1.1 General

The safety provisions specified in this chapter shall apply to demolition and dismantling of all types of buildings and structures in addition to the safety requirements mentioned in Chapter 3.

4.1.2 Planning

Before commencing the demolition work, a detailed survey and study shall be made of the structure to be demolished and the structures in its surroundings. This shall include the manner in which the various parts of the building to be demolished are supported and how far the demolition will affect the safety of the surrounding structures. Planning for demolition and safety of adjoining structures shall be made accordingly.

The sequence of operations shall be planned by an Engineer-in-charge recognized by the Authority as having experience in demolition work of similar magnitude. No deviation from the approved plan shall be permitted without the approval of the Engineer-in-charge. Before the commencement of each stage of demolition, the foreman shall brief the workmen in detail regarding the safety aspects to be kept in view.

Demolition of buildings and structures shall be carried out under supervision of qualified Engineer and with prior notification to the Authority as prescribed by the latter.

The Authority may require the permittee to submit the plans and a schedule of demolition. Neighbors and public shall be notified of the intended demolition through newspaper or other media. The extent, duration and time of the demolition shall be clearly specified in the notice.

4.1.3 Protection of Adjoining Property

A written notice shall be delivered to the owner of each potentially affected plot, building or structure at least a week in advance of the commencement of work. The notice shall request written permission to enter the plot, building or structure prior to the commencement of work and as and when required during the work to inspect and preserve them from damage.

Owner of the structure to be demolished or dismantled shall under all circumstances preserve and protect the adjoining lot, building or structure from damage or injury. This shall be done at his own expense.

In case damage to the adjoining property is imminent, the demolition operation shall be stopped forthwith and shall not be restarted until the necessary measures to prevent such damage have been taken. All waste materials and debris from the demolition shall be removed immediately.

If the owner of the property to be demolished is denied entry to an adjoining structure, he shall immediately notify the Authority in writing of such denial. In this situation, the Authority may hold the adjoining property owner fully responsible for any damage to his property.

4.1.4 Precautions prior to Demolition

Demolition of any building shall not commence until the required pedestrian protection structures in accordance with Sec 4.1.5 of this Chapter have been built. Building or structure damaged by fire, flood, explosion or earthquake, shall be protected from collapse by way of bracing, shoring etc. before demolition is commenced.

Permission shall be secured from the Authority for using explosives. General public and owners of the adjoining properties shall be notified beforehand of such use. All precautions as required by Sec 2.2.5.3 Chapter 2 and Sec 4.3 Chapter 4 of this Part shall have to be ensured before, during and after the use of the explosives.

Danger signs shall be posted round the property; this shall conform to the relevant sections of Part 10. All entrances shall be barricaded or manned. At least two independent exits shall be provided at night; warning lights shall be placed above all barricades during the night and dark hours. Even when work is not in progress, watchmen shall be provided to prevent unauthorized entry of the public in the danger zone.

4.1.5 Protection of Public

Safe distances shall be clearly marked and prominent signs posted. Every sidewalk and road adjacent to the site shall be either closed or protected. All public roads shall be kept open and unobstructed at all times unless unavoidable circumstances arise.

If a covered walk is not necessary in the opinion of the Engineer-in-charge he shall issue a permit to block off part of the sidewalk and have a temporary walk provided. Pedestrians shall be provided with diversion roads or alternate protection as specified in Sec 1.7 Chapter 1 and Table 7.4.1.

All utility lines shall be disconnected upon the approval of the concerned Authorities. Temporary service connection for the demolition work shall be taken separately. See Sections 3.3.9 and 3.3.12 of Chapter 3 for other requirements.

Workmen shall be provided with all necessary safety appliances as specified in the following sections and in Chapter 3 prior to the start of work. Safety precautions for fire shall be provided.

The site shall be thoroughly cleaned of combustible materials and debris before commencement of demolition.

4.1.6 Sidewalk Shed and Canopies

A toe board at least 1 m high above the roof of the shed shall be provided on the outside edge and ends of the sidewalk shed. Such boards may be vertical or inclined outward at no more than 45° angle with the vertical. The side of the shed adjacent to the building shall be completely blocked by planking/sheeting.

The roof of sidewalk sheds shall be capable of sustaining a load of 7 kPa. Impact of falling debris shall be considered in designing and constructing the shed. Maximum load on the roof of the shed shall be maintained below 12 kPa.

The flooring of the sidewalk shed shall consist of closely laid planks with a minimum thickness of 50 mm made watertight. Only in exceptional cases, temporary storage on the sidewalk shed may be permitted; in such situation, the roof of the shed shall be designed for sustaining 14 kPa.

Entrances to the building shall be protected by canopies extending at least 2.5 m from the building facade. Such overhead protection shall be at least 600 mm wider than the entrance, and 2.5 m in height.

4.2 Precautions During Demolition

4.2.1 General

The owner shall provide protection against all damages or loss of life and property during demolition. Constant supervision shall be provided during a demolition work by a competent and experienced engineer.

The demolition site shall be provided with sufficient natural and artificial lighting and ventilation.

All existing features required during demolition operations shall be well protected with substantial covering to the entire satisfaction of the rules and regulations of the undertakings or they shall be temporarily relocated.

For a building or structure more than 8 m or two stories high, all windows and exterior wall openings that are within 6 m of floor opening used for the passage of debris from floors above, shall be solidly boarded. Openings in floors below the level of demolition, not used for removal of materials or debris, shall be barricaded or covered by planks.

4.2.2 Sequence of Demolition Operation

The demolition shall proceed in descending order and storey by storey. All work in the upper floor shall be completed and approved by the engineer prior to disturbing any supporting member on the lower floor. Demolition of the structure in sections may be permitted in exceptional cases only if necessary precautions are ensured. The demolition work shall proceed within such a way that:

it causes the least damage and nuisance to the adjoining building and the members of the public, and it satisfies all safety requirements to avoid any accidents.

Table 7.4.1: Type of Protection Required for Pedestrians near a Demolition Site

Horizontal Distance from inside of the Sidewalk to the Structure	Height* to Horizontal Distance Ratio	Type of Minimum Protection Required
Less than 3 m	6:1 or more	Type A
	4:1 - 6:1	Type B
	3:1 - 4:1	Type C
	2:1 - 3:1	Type D
	up to 2:1	Type E
3 m - 4.5 m	10:1 or more	Type A
	6:1 - 10:1	Type B
	4:1 - 6:1	Type C
	3:1 - 4:1	Type D
	up to 3:1	Type E
4.5 m - 7.5 m	15:1 or more	Type A
	10:1 - 15:1	Type B
	6:1 - 10:1	Type C
	4:1 - 6:1	Type D
	up to 4:1	Type E
7.5 m - 12 m	15:1 or more	Type B
	10:1 - 15:1	Type C
	6:1 - 10:1	Type D
	up to 6:1	Type E
12 m and more	10:1 or more	Type D
	up to 10:1	Type E

* Height of the building or portion thereof to be demolished

Type A: Total blockade of the road.

Type B: Temporary diversion over the entire length of the footpath adjacent to the structure.

Type C: A sidewalk shed for the entire length, in accordance with Sec 4.1.6.

Type D: A fence of tightly seated 25 mm planks, minimum height 2.5 m.

Type E: A railing at least 1.5 m high with mid rail and cross bracing.

4.2.3 Wall

Walls shall be removed part by part in reasonably level courses. No wall or any part of the structure shall be left in a condition that may collapse or be toppled by wind, vibration etc.

Fall of the demolished wall in large chunks, which endangers the adjoining property or exceeds the safe load capacity of the floor below, shall be avoided. Debris shall be removed at frequent intervals to avoid piling up and overloading of any structural member.

Platforms shall be provided for demolition of walls less than one and half brick thick. Lateral bracing shall be provided for sections of walls having a height more than 22 times its thickness, or otherwise considered unsound. No workman shall stand on any wall to remove materials; staging or scaffold shall be provided at a maximum of 3.5 m below the top of the wall.

At the end of each day's work, all walls shall be left stable to avoid any danger of getting overturned. Foundation walls which serve as retaining walls shall not be demolished until the adjoining structure has been underpinned or braced and the earth removed.

4.2.4 Floor

Support/centering shall be provided prior to removal of masonry or concrete floor. Planks of sufficient strength shall be used in shuttering. No person shall be allowed to work in an area underneath a floor being removed; such areas shall be barricaded.

The total area of a hole cut in any intermediate floor for dropping debris shall not exceed 25% of that floors' area. No barricades or rails for guarding the floor hole shall be removed until the storey immediately above has been demolished down to the floor line and all debris cleared from the floor.

In cutting holes in a floor which spans in one direction, at first, a maximum 300 mm wide slit shall be cut along the entire length of the slab; the slit shall be increased gradually thereafter.

Planks of sufficient width, not less than 50 mm thick, 250 mm wide and 2 m long shall be provided at spacing not greater than 400 mm for the workmen to work. These shall be so spaced as to firmly support the workmen against any floor collapse.

4.2.5 Special Elements**4.2.5.1 Catch Platform**

Catch platform shall be provided during demolition of exterior walls of structures more than 20 m in height. These shall be constructed and maintained not more than three storeys below the storey from which exterior wall is being demolished.

Catch platform shall not be used for storage or dumping of materials. These shall be capable of sustaining a minimum live load of 7 kPa. The out-riggers shall not be placed more than 3 m apart.

Additional requirements of Sec 1.4.3 Chapter 1 and Sec 4.1.6 Chapter 4 of this Part shall also be followed.

4.2.5.2 Stairs, Passageways and Ladders

Make-shift stairs with railings, passageways, and ladders shall be left in place as long as possible, and maintained in a safe condition. They shall not be removed from their position unless instructed by the foreman. See also Sections 3.5.3 and 3.13.1 of Chapter 3 of this Part for additional requirements.

4.2.5.3 Roof Trusses and Steel Structures

Structural frame of a pitched roof shall be removed to wall plate level by hand methods. Sufficient purlins and bracing shall be retained to ensure stability of the remaining roof truss while each individual truss is removed progressively. The bottom tie of roof trusses shall not be cut until the principal rafters are secured against making outward movement.

Temporary bracing shall be provided, where necessary, to maintain stability. All trusses except the one being dismantled shall be independently and securely guyed in both directions before work starts.

Hoisting gear suitable for the loads to be lifted shall be provided. A truss or a part thereof shall not be put on a floor; it may be allowed to rest only temporarily on the floor below if it can be ensured that the floor is capable of taking the load.

The steel frame may be left in place during demolition of masonry work. All steel beams/girders shall be cleared of all loose materials as the demolition of masonry work progresses downward provided it is still strong enough to stand as an independent structure.

4.2.5.4 Heavy Floor Beam

Heavy timber and steel beams shall be supported before cutting at the extremities. Beams shall be lowered gently and kept in a distant place without obstructing any passageway.

4.2.5.5 Jack Arch

Arches shall be demolished by standing on scaffolding clear of the arch. Tie rods between main supporting beams shall not be cut until the arch or series of arches have been removed. The floor shall be demolished in strips parallel to the span of the arch rings at right angles to the main floor beam.

4.2.5.6 Brick Arch

Abutments shall not be removed before the dead load of the spandrel wall and the arch rings are removed. A single span arch can be demolished by hand cutting narrow segments progressively from each springing parallel to the span of the arch until its width has been reduced to a minimum. The remainder of the arch can then be collapsed.

The crown may be demolished by the demolition ball method progressively from edges to the centre. Explosives may be used for a complete collapse of the structure by inserting charges into bore holes drilled in both the arch and the abutments.

In multi-span arches, lateral restraint shall be provided at the springing level before individual arches are removed. Demolition procedures as for single span may then be applied. Special temporary support shall be provided in the case of skew bridges.

No partial demolition leaving unstable portion standing shall be allowed. Where debris cannot be allowed to fall to the ground, centering capable of carrying load of the debris shall be designed and provided accordingly.

4.2.5.7 Cast-in-Situ RC

Before commencing demolition, the nature and condition of concrete and position of reinforcement and the possibility of lack of continuity of reinforcement shall be ascertained.

Demolition of cast-in-situ RC members shall start by removing partitions and external non-load bearing cladding and other decorative features.

Reinforced concrete beams shall be demolished one at a time after the slabs have been removed.

Ties shall be attached to the beam to support the beam when suspended.

The reinforcement near the supports shall first be exposed by drilling with pneumatic drill and removing the concrete. The reinforcement shall then be cut at both supports in such a way as to allow the beam to be lowered to the floor or the ground under control.

RC columns and any other supporting columns of one level shall only be demolished after all other building elements of that level have been completely removed.

The reinforcement in columns shall be exposed at the base after restraining wire guy ropes have been placed round the member at the top. The reinforcement shall then be cut in a way to allow it to be pulled down to the floor or the ground under control.

Reinforced concrete walls shall be cut into strips and demolished in the same way as concrete columns.

4.2.5.8 Precast Reinforced Concrete

Precautions in the form of providing temporary supports or balancing weights shall be taken to avoid toppling over of prefabricated units or any other part of the structure.

4.2.5.9 Suspended Floor, Roof and Cantilevered Structure

Suspended floor and roof slabs shall be cut into strips parallel to the main reinforcement and demolished strip by strip. For ribbed floors, the principle of design and method of construction shall be considered and procedures determined accordingly.

Ribs and beams shall never be cut at their mid-span and without securing by ties. Cantilevered portions, canopies, cornices, staircases and balconies shall be demolished after providing support to the portion before demolition of the main structure.

4.2.6 Mechanical Demolition

Mechanical demolition shall be restricted to a height of 25 m. When mechanical devices, such as weight ball and power shovels are used in demolition work, the area shall be barricaded up to a minimum distance of one and a half times the height of the wall in addition to the requirements laid out in Table 7.4.1.

While the mechanical device is in operation, no person shall be allowed to enter the building.

Location of the devices shall be such that it is neither hit by falling debris nor it causes any damage to adjacent structure, power line, etc.

4.2.7 Miscellaneous

No demolition work shall be carried out at night, or during storm or heavy rain. If demolition has to be done at night, precautions in the form of red warning signals, sirens, working lights and watchmen shall be provided. Auditory warning devices shall be installed at the demolition site.

Safety devices like industrial safety helmets (BDS 1265, BDS 1266), boots, gloves, goggles made of celluloid lens (BDS 1360), safety belts (BDS 1359) etc. shall be used by the workmen.

First aid box shall be made available at all demolition sites. In fire-risk area, appropriate portable firefighting appliances shall be kept at hand. See also Sections 3.11.2 and 3.11.3 Chapter 3 of this Part.

4.3 Blasting Operation and Use of Explosives

4.3.1 General

Before any work involving the use of explosives is started, a detailed survey and examination of the site, buildings or structures and adjoining areas and property shall be made. Due care shall be taken to avoid disruptions or damage to underground wells, tunnels, storage tanks etc.

Proximity of underground and overground services shall be carefully considered before blasting operations are carried out. Relevant authorities responsible for concealed underground works shall be duly consulted. Special attention shall be paid to the presence of power cables, radio and television transmitting stations sited within 3 km of the site.

Experts shall be consulted before proceeding with any work where sources of danger like flammable gases or liquids, sewage and drainage, unexploded missiles or mines, waste, explosive etc. are likely to be found. Also see Sec 4.1.

4.3.2 Code of Signal

Before any blasting commences on the construction or demolition site, both audible and visual signaling systems giving warning of blasting operations shall be established. These shall be such that they can be clearly heard and seen by site personnel working within the site areas, and also by the general public who may be affected.

Audible warnings shall comprise a series of readily recognizable signals with a distinctive tone. The Code of signals, once established for a particular site, shall not be altered without good reason and adequate warning to personnel.

Visual signs shall comprise clearly painted notices posted on all access roads to the site. Sentries shall be posted at the entries at blasting times with clear instructions; if necessary, they shall warn personnel who failed to hear warning signals or see signs.

4.3.3 Supervision and Responsibility

Only competent persons shall be employed as shotfirers. When subcontractors are taking part in the work on same site, the main contractor shall ensure a close liaison and collaboration with other contractors.

All site personnel present during blasting operations shall come under the control of the shotfirer.

All explosives shall be under the control of the shotfirer.

The handling of explosives on the site shall be restricted to personnel who are required to do so in the discharge of their duties and who are authorized in writing by the engineer. All site personnel shall be warned against maltreatment of explosives and blasting accessories.

4.3.4 Protection of site Personnel and Installations

The contractor shall provide all tools and equipment used in charging and firing blasts. The shotfirer shall inform the engineer the necessity of replacing any item. Shotfiring cables shall be examined before use for cuts or abraded insulation.

Circuit testers and exploders shall be handled with care and used and maintained according to the manufacturer's instructions; any malfunction shall immediately be reported and repair shall be carried out only by a competent person.

The area where explosives are to be used shall be defined before the charging of blasts. Vehicles and other mobile equipment shall be prohibited from entering the defined blast area, except as required to deliver or remove explosives.

All personnel shall be instructed as to what places of shelter they are to take up during blasting operations. Mobile plant and equipment shall be moved to a place of shelter and switched off when a blast is to be fired.

After a blast, no personnel shall be allowed to return to the danger area until the shotfirer has conducted a general examination and declared the site safe. The shotfirer shall not return to the blasting site until at least 5 min has elapsed after firing.

Electric detonators shall only be carried in boxes made of non-conducting materials, with a lid and catch. The shotfirer shall maintain a check on the number of detonators used against number issued. The boxes shall be kept locked until detonators are needed.

Blasting shall not be carried out in confined spaces without adequate ventilation; positive ventilation at the working face shall be maintained at all times.

No members shall be cut until precautions have been taken to prevent it from swinging freely. All structural steel members shall be lowered from the building and shall not be allowed to drop.

4.3.5 Safety of Third Parties

The safety of persons who reside or work in the vicinity of the site shall be considered. Where necessary, they shall be advised to vacate their homes or offices during blasting operations. In addition to notices giving warning of blasting on all roads and paths approaching the site, sentries shall be posted to maintain surveillance around the site when blasting is in progress.

Blasts shall normally be fired during the hours of daylight. The blasting technique and period shall be chosen so that any annoyance to the general public from noise, ground vibration, dust etc. is reduced to a minimum.

In heavily built-up areas, small-scale short delay blasting techniques employing light charges in small diameter holes shall be adopted. In such situations, short holes shall be carefully placed and charge weights correctly chosen. Sand bags, blasting mats or other screening material of suitable construction shall be placed over the top of each hole.

4.3.6 Use of Explosives

A sketch plan with sufficient duplicate copies shall be prepared for each blast. Before the explosive is deposited at the point of use, a check shall first be made of the depth of each shot hole. The engineer shall be informed of any departure from the planned arrangement.

Exposure to any compressive action or severe effect of a similar kind shall be avoided and grinding, scouring or rubbing actions eliminated. The vigorous use of stemming rods to force explosives into a hole shall be avoided. There shall be adequate clearance to allow easy insertion of the cartridges into the shot holes. The wrapping of the explosive cartridge shall not be removed, nor the cartridge be cut.

Primers shall not be made up in a magazine, or near excessive quantity of explosives, or in excess of immediate use. No attempt shall be made to use fuses, blasting caps, or explosives which have been water soaked. No attempt shall be made to soften hard set explosives by heating or rolling.

A bore hole shall not be loaded with explosives after springing unless it is cool and does not contain any hot metal. Temperature in excess of 65° C is dangerous. A bore hole near another hole loaded with explosives shall not be sprung.

No attempt shall be made to slit, drop, deform or abuse the primer. No metallic device shall be used in tamping. Wooden tamping tools with no exposed metal parts except non-sparking metal connectors for jointed poles shall be used.

4.3.7 Blasting Accessories

No person shall attempt to uncoil the wires and open out the short circuited bare leading wires of the electric blasting cap during approach of dust storm, or near sources of large charge of static electricity or near a radio transmitter. Firing circuit shall be kept completely insulated from the ground, other conductors, paths or stray current.

Except at the time and for the purpose of firing the blast, there shall be no electric live wires or cables near electric blasting caps or other explosives. All wire ends to be connected shall be bright and clean. The electric cap wires or leading wires shall be kept short-circuited until ready to fire.

All electric blasting caps shall be tested both singly and when connected to a circuit. Electrical blasting caps made by more than one manufacturer or electric blasting caps of different design or function, even if made by the same manufacturer, shall not be used in the same circuit. These shall not be fired by less than the minimum current specified by the manufacturer.

Where energy for blasting is taken from power circuits, the voltage shall not exceed 220 V. A safety switch, the same type as the blasting switch, shall be installed between the blasting switch and the firing circuit and lead lines at a distance not exceeding 1800 mm from the blasting switch.

Both safety switch and blasting switch shall be locked in the open position immediately after firing the shot. Key to the switches shall remain with the shotfirer at all times. Blasting shall be carried out using suitable exploder with 25% excess capacity.

Rubber covered or other adequately insulated copper wires shall be used for firing lines; sufficient firing line shall be provided. Single conductor lead lines shall be used. All holes loaded on a shift shall be fired on the same shift.

In very cold weather, the safety fuse shall be slightly warmed before using. Short fuse shall not be used. The length of a fuse shall be at least 1200 mm and the maximum burning rate 600 mm/min.

A fuse shall not be cut until the blasting cap is ready. The fuse shall be cut squarely across about 50 mm with a clean and sharp blade to ensure a dry end.

The fuse shall not be twisted after it has been seated lightly against the cap charge. Blasting caps shall not be crimped except by a cap crimper designed for the purpose. The cap shall be squarely crimped to the face.

The fuse shall be lighted with a fuse lighter designed for the purpose. It shall not be lighted until sufficient stemming has been placed over the explosives. The explosives shall not be held in hands when lighting the fuse.

In case of firing with safety fuse, the number of loud reports shall be counted; in the event of misfire, no person shall be allowed to the blasting site for at least 30 minutes. An inspection for remaining of un-detonated explosives shall be made; all misfired shot holes shall be marked.

If the misfire is due to faulty wiring or connection, the defect shall be remedied and the shotfired.

The stemming shall be floated out by using hose water until the hole has been opened to within 600 mm of the charge; the water shall be siphoned out thereafter and a new charge placed or, a new hole drilled 600 mm away from the old bore and parallel to it and about 300 mm less in depth and the new hole charged and duly fired.

4.4 Lowering, Removal and Disposal of Materials

4.4.1 General

No material shall be dropped or thrown on the ground or outside the exterior walls. They shall be lowered either in containers or by ropes, tackles, properly designed wood or metal chutes etc.

When the removal of any material causes an excessive amount of dust, it shall be wet before lowering or dropping, if feasible. Tag lines shall be used on all materials being lowered or hoisted up and a standard signal system shall be used and the workmen instructed on the signals. No person shall be permitted to ride the load line.

4.4.2 Use of Chutes

Chutes, if provided, shall be at the centre of the building. It shall have an angle of more than 45° with the horizontal, and shall be entirely closed on all sides except at the opening for receiving the material. The chute opening shall be kept locked. The top opening of chute shall be protected with guard rails.

Debris may be dropped through holes in the floor, if absolutely necessary. Precautions shall be taken to avoid overloading of the floor with debris. The debris dropping area shall be protected by rails.

4.4.3 Removal of Debris

Temporary stacking of demolished materials at the site shall be done in a manner ensuring fire prevention and orderly removal. Debris shall be removed from the site as soon as possible. Materials like glass, nails, etc. shall not be strewn about. Standard precautions to prevent fire from debris shall be taken.

4.4.4 Disposal of Materials

Demolished materials shall be disposed of according to their salvage value. Materials, which can be re-used, shall be salvaged and re-used with the approval of the owner.

Rubbish having no salvage value shall be removed from the site and disposed of according to the local statutory rules and regulations. Rubbish of combustible materials shall be disposed of immediately. All such operations shall have the approval of the owner.

4.4.5 Regularization of Plots

If there is no immediate construction planned on the plot vacant after demolition, it shall be filled, graded and maintained in conformity to the established street grades at curb level. The plot shall be maintained free from the accumulation of rubbish and water, and all other unsafe and hazardous conditions.

Provisions shall be made to prevent damage to any foundation on the premises or on the adjoining property. All previous service connections shall be capped.

PART VII
Chapter 5
Maintenance Management, Repairs, Retrofitting
and Strengthening of Buildings

5.1 Maintenance Management

Maintenance management of building is the art of preserving over a long period what has been constructed. Whereas construction stage lasts for a short period, maintenance continues for comparatively very large period during the useful life of building. Inadequate or improper maintenance adversely affects the environment in which people work, thus affecting the overall output and also the overall service life of the building. In the post construction stage the day to day maintenance or upkeep of the building shall certainly delay the decay of the building structure. Though the building shall be designed to be very durable it needs maintenance to keep it in good condition.

5.2 Terminology

For the purpose of this Section, the following definitions shall apply.

BUILDING FABRIC	Elements and components of a building other than furniture and services.
BUILDING MAINTENANCE	Work undertaken to maintain or restore the performance of the building fabric and its services to provide an efficient and acceptable operating environment to its users.
CONFINED SPACE	Space which is inadequately ventilated for any reason and may result in a deficiency of oxygen, or a build-up of toxic gases, e.g. closed tanks, sewers, ducts, closed and unventilated rooms, and open topped tanks particularly where heavier than air gases or vapors may be present.
HOUSEKEEPING	The routine recurring work which is required to keep a structure in good condition so that it can be utilized at its original capacity and efficiency along with proper protection of capital investment, throughout its economic life.
MAINTENANCE	The combination of all technical and associated administrative actions intended to retain an item in or restore it to a state in which it can perform its required function.
MAINTENANCE MANAGEMENT	The organization of maintenance within an agreed policy. Maintenance can be seen as a form of 'steady state' activity.

OWNER	<p>Person or body having a legal interest in a building. This includes freeholders, leaseholders or those holding a sub-lease which both bestows a legal right to occupation and gives rise to liabilities in respect of safety or building condition.</p> <p>In case of lease or sub-leaseholders, as far as ownership with respect to the structure is concerned, the responsibility of structure of a flat or structure on a plot belongs to the allottee/lessee during the leasehold.</p>
-------	---

Provisions of Sections 8.1 and 8.2 of Chapter 8 Part 6 shall apply for detailing of reinforced concrete members, in general. For reinforced concrete structures, subject to earthquake loadings in zone 2 and zone 3, special provisions contained in Sec 8.3 of this chapter shall apply.

5.3 Building Maintenance

5.3.1 General

Any building (including its services) when built has certain objectives and during its total economic life, it has to be maintained. Maintenance is a continuous process requiring a close watch and taking immediate remedial action. It is interwoven with good quality of housekeeping. It is largely governed by the quality of original construction. The owners, engineers, constructors, occupants and the maintenance agency are all deeply involved in this process and share a responsibility. Situation in which all these agencies merge into one is ideal and most satisfactory.

There are two processes envisaged, that is, the work carried out in anticipation of failure and the work carried out after failure. The former is usually referred to as preventive maintenance and the latter as corrective maintenance. The prime objective of maintenance is to maintain the performance of the building fabric and its services to provide an efficient and acceptable operating environment to its users.

Maintenance in general term can be identified in the following broad categories.

- (a) Cleaning and servicing - This is largely of preventive type, such as checking the efficacy of rain water gutters and servicing the mechanical and electrical installations. This covers the house keeping also.
- (b) Rectification and repairs - This is also called periodical maintenance work undertaken by, say, annual contracts and including external re-plastering, internal finishing etc.
- (c) Replacements - This covers major repair or restoration such as reproofing or re-building defective building parts.

5.3.2 Factors Affecting Maintenance

Maintenance of the buildings is influenced by the following factors:

- (a) Technical factors - These include age of building, nature of design, material specifications, past standard of maintenance and cost of postponing maintenance.
- (b) Policy - A maintenance policy ensures that value for money expended is obtained in addition to protecting both the asset value and the resource value of the buildings concerned and owners.
- (c) Environmental - All buildings are subject to the effects of a variety of external factors such as air, wind precipitation, temperature etc. which influence the frequency and scope of maintenance.

The fabric of building can be adversely affected as much by the internal environment as by the elements externally. Similar factors of humidity, temperature and pollution shall be considered. Industrial buildings can be subject to many different factors subject to processes carried out within. Swimming pool structures are vulnerable to the effects of chlorine used in water.

- (d) User - The maintenance requirements of buildings and their various parts are directly related to the type and intensity of use they receive.

5.3.2.1 Influence of design

The physical characteristics, the life span and the aesthetic qualities of any building depend on the considerations given at the design stage. All buildings, however well designed and conscientiously built, will require repair and renewal as they get older. However, for better performance of the building envelop, the following are the ways to minimize troubles at the later stage:

- (a) Minimize defects during construction and design.
- (b) Detail and choose materials during construction so that the job of maintenance is lessonerous.

In addition to designing a building for structural adequacy, consideration shall also be given to environmental factors such as moisture, natural weathering, corrosion and chemical action, user wear and tear, pollution, flooding, subsidence, earthquake, cyclones etc.

5.3.3 Maintenance Policy

The policy shall cover such items as the owner's anticipated future requirement for the building taking account of the building's physical performance and its functional suitability. This shall lead to decisions regarding:

- (a) the present use of the building anticipating any likely upgrading and their effect on the life cycles of existing components or engineering services; and
- (b) A change of use for the building and the effect of any conversion work on the life cycles of existing components or engineering services.

5.3.4 Maintenance Work Programmes

The programming of maintenance work can affect an owner or his activities in the following ways:

- (a) Maintenance work shall be carried out at such times as are likely to minimize any adverse effect on output or function and with due consideration to the comforts of the occupants and public and Third Party stakeholders.
- (b) Programme shall be planned to obviate as far as possible any abortive work. This may arise if upgrading or conversion work is carried out after maintenance work has been completed or if work such as rewiring is carried out after redecoration.
- (c) Any delay in rectifying a defect shall be kept to a minimum only if such delay is likely to affect output or function. The cost of maintenance increases with shortening response times.
- (d) Maintenance work, completed or being carried out shall comply with all statutory and other legal requirements.

5.3.5 Maintenance Guides

An owner responsible for a large number of buildings has to established procedures for maintenance. When an owner is responsible for the maintenance of only one building or a small number of buildings, the preparation of a guideline manual tailored to suit each particular building, can offer significant advantages. Such a manual shall take into account the following.

- (a) Type of construction and residual life of the building, and
- (b) Environment and intensity of use (see Sec 5.3.2).

The guide shall form part of a wider manual covering operational matters.

5.3.6 Planning of Maintenance Work

Work shall take account of the likely maintenance cycle of each building element and be planned logically, with inspections being made at regular intervals. Annual plans shall take into account subsequent years' programmed to incorporate items and to prevent additional costs. It shall be stressed that the design of some buildings can lead to high indirect costs in maintenance contracts and therefore, careful planning can bring financial benefits. Decisions to repair or replace shall be taken after due consideration.

5.3.7 Feed Back

Feed back is normally regarded as an important procedure of providing information about the behaviour of materials and detailing for the benefit of the architect and engineer designing new buildings, which will result in lessening maintenance costs. It is an equally valuable source of information for the persons responsible for maintenance. Every maintenance organization shall develop a sample way of communicating its know-how, firstly for benefit of others in the organization and secondly for the benefit of the building industry as a whole. There shall be frank and recorded dialogue on an on-going basis between those who occupy and care for buildings and those who design and construct them.

Feedback shall aim at the following:

- (a) User satisfaction.
- (b) Continuous improvement, and
- (c) Participation by all.

The information on feed back can be obtained from the following:

- (a) Occupants,
- (b) Inspections,
- (c) Records, and
- (d) Discussions.

5.3.8 Means of Effecting Maintenance

Some maintenance work will be carried out by the occupier of a building or by the occupier's representative. In the case of leasehold or similar occupation not all maintenance shall be the responsibility of occupier. The regular maintenance shall be clearly mentioned in the tenancy agreement. Responsibility of common areas shall be clearly defined.

Maintenance work sub-divided into major repair, restoration, periodical and routine or day-to-day operations will be undertaken by one of the following.

- (a) Directly employed labour.
- (b) Contractors, and
- (c) Specialist contractors under service agreement or otherwise.

The merits of each category for typical maintenance work must be considered because optimum use of resources appropriate to tasks in a given situation is an important element of policy.

The success of contracting out depends on the nature of the services, conditions in which contracting is undertaken (the tendering process), how the contract is formulated and subsequent monitoring of service quality. The important consideration in the decision to contract out is whether a contractor can ensure a socially desirable quantity and quality of service provision at, a reasonable cost to the consumers.

5.4 Access

5.4.1 General

All maintenance activities including any preliminary survey and inspection work require safe access and in some situations this will have to be specially designed. Maintenance policy, and maintenance costs, will be much influenced by ready or difficult access to the fabric and to building services. Special precautions and access provisions shall also need to be taken for roof work or for entry into confined spaces such as ducts or voids.

5.4.2 Access Facilities

Permanent accessibility measures shall be provided at the design stage only for all the areas for safe and proper maintenance. It is a matter on which those experienced in the case of the building can make an important contribution at design stage in the interest of acceptable maintenance costs.

A wide variety of temporary access equipment shall appropriately be provided for maintenance work, ranging from ladders to scaffoldings or powered lift platforms.

Wherever possible it is better to provide permanent access facilities such as fixed barriers, ladders, and stairways. When such permanent access facilities are provided necessary arrangement shall be included in maintenance plans for their regular inspection, maintenance and testing.

All personnel employed for carrying out maintenance shall be provided with the necessary protective clothing and equipment and instructed in its use.

When physical access is not possible in situations such as wall cavities, drains etc. inspections shall be made with the aid of closed circuit television or optical devices such as endoscopes.

5.4.3 Access to Confined Spaces

5.4.3.1 Ventilation

Good ventilation shall be necessary in order that maintenance work can be carried out safely. This is especially important in confined spaces. When the normal ventilation is inadequate it shall be supplemented by temporary and forced ventilation installations. These shall provide general and spot ventilation as appropriate.

Special precautions need to be taken when entering a confined space. Such confined spaces shall be adequately ventilated and trapped gas removed, particularly before being entered, to ensure that they are free from harmful concentrations of gases, vapors other airborne substances and that the air is not deficient in oxygen.

5.4.3.2 Lighting

Good lighting is necessary in order that maintenance work can be carried out satisfactorily. This is particularly important in confined spaces. When the normal lighting is inadequate it shall be supplemented by temporary installations. These shall provide general and spot illumination as appropriate.

5.5 Records

5.5.1 General

Good records can save owners and users/occupiers much unnecessary expense and reduce potential hazards in exploration work when faults arise.

5.5.2 Use of Building Records

All personnel involved in the maintenance of the building shall be made aware of the existence of the building records.

Known hazardous areas shall be explicitly marked on the records as well as being marked on site and shall be pointed out to such personnel together with any system of work adopted for use in such areas.

Records are of value only if they are kept up to date and arrangements for this shall be included in any provision that may be made for records.

Records shall be readily accessible for use and the place of storage shall take into account the form of the records and the conditions needed to keep them from damage of any kind. It is recommended that a duplicate set of records is kept in a secure place other than building itself and is kept up to date.

Following shall be typical contents of the maintenance records:

- (a) A brief history of property, names and addresses of consultants and contractors.
- (b) Short specifications, constructional processes, components, material finishes, hidden features, special features etc.
- (c) “As built” plans and as subsequently altered with sections, elevations and other detailed drawings.
- (d) Foundation and structural plans/sections such as concrete reinforcement drawings.
- (e) Detail specification of all materials incorporated, for example, concrete mix, species and grades of timber etc. Potentially hazardous materials and types or methods of construction that under some circumstances may become hazardous shall be identified.
- (f) Information on housekeeping and routine maintenance with details of internal and external surfaces and decorations, schedule of cleaning, inspection and maintenance.
- (g) Means of operating mechanical, electrical and plumbing installations.
- (h) Description of renovations, extensions, adaptations and repair to each element.
- (i) All plant, machinery and propriety articles including manufacturers trade literature and instructions for installation, use and maintenance.
- (j) Methods of work used in construction such as assembly of prefabricated units.
- (k) All information related to fire such as:
 - Location and service arrangements of all fire alarm and call points;
 - Location and service arrangements of all extinguishers, hose reels and other firefighting installations;
 - Location of all fire compartment walls, doors, floors and screens;
 - Location of all areas of exceptional fire hazard;
 - Fire escape routes;
 - Details of application of any fire protection treatment; and
 - Location details and description of any installation for smoke control or protection of escape routes.
- (l) There shall be a wall chart showing at a glance the various operations which have to be undertaken. Line drawings of buildings are always to be there.
- (m) Records of security measures shall be known to Authorized personnel only.
- (n) Where no records exist, information shall be slowly built up as it becomes available during the course of maintenance work.
- (o) Use of computers for storing information shall be compulsory.

5.5.3 Mechanical Records

5.5.3.1 Documentation

Documentation shall record the following as installed.

- (a) The location, including level if buried, of all public service connections (for example, fuel gas and cold water supplies) together with the points of origin and termination, size and materials of pipes, line pressure and other relevant information.
- (b) The layout, location and extent of all piped services showing pipe sizes, together with all valves for regulation, isolation and other purposes as well as the results of all balancing, testing and commissioning data.
- (c) The location, identity, size and details of all apparatus and all control equipment served by, or associated with, each of the various services together with copies of any test certificates for such apparatus where appropriate. The information with respect to size and details shall be presented in schedule form.
- (d) The layout, location and extent of all air ducts showing dampers and other equipment, acoustic silencers, grilles, diffusers or other terminal components. Each duct and each terminal component shall be marked with its size, the air quantity flowing and other relevant balancing data, and
- (e) The location and identity of each room or space housing plant, machinery or apparatus.

5.5.3.2 Drawings

Drawings shall record the following as installed.

- (a) Detailed general arrangements of boiler houses, machinery spaces, air handling plants, tank rooms and other plant or apparatus, including the location, identity, size and rating of each apparatus, The information with respect to the size and rating can be presented in schedule form;
- (b) Isometric or diagrammatic views of boiler houses, plant rooms, tank rooms and similar machinery, including valve identification charts. It is useful to frame and mount a copy of such drawings on the wall of the appropriate room, and
- (c) Comprehensive diagrams that show power wiring and control wiring and /or pneumatic or other control piping including size, type or conductor or piping used and identifying the terminal points of each.

5.5.4 Electrical Records

Documentation shall record the following including locations, as installed.

- (a) Main and sub main cables, showing origin, route, termination, size and type of each cable; cables providing supplies to specialist equipment, for example, computers, shall be identified separately; and
- (b) Lighting conduits and final sub circuit cables, showing origin, route, termination and size of each, together with the number and size of cables within each conduit. The drawings shall indicate for each conduit or cable, whether it is run on the surface or concealed, for example, in a wall chase, in a floor screed, cast in-situ, above a false ceiling etc.

These drawings shall also indicate the locations of lighting fittings, distribution boards, switches, draw-in-boxes and point boxes, and shall indicate circuitry.

- (a) Location and purpose of each emergency lighting fitting including an indication of the circuit to which it is connected.
- (b) Single and three phase power conduits and final sub circuit cables showing locations of power distribution boards, motors, isolators, starters, remote control units, socket outlets and other associated equipment.
- (c) Other miscellaneous equipment, conduits and cables.
- (d) Lightning conductor, air terminals, conductors, earth electrodes and test clamps.
- (e) Location of earth tapes, earth electrodes and test points other than those in(f); and
- (f) Cables providing earth circuits for specialist equipment, for example computers, shall be identified separately.

Documentation shall also include, when applicable.

- (a) Distribution diagrams or schedules to show size, type and length (to within 1 m) of each main and sub main cable, together with the measured earth continuity resistance of each.
- (b) Schedule of lighting fittings installed stating location, manufacturer and type or catalogue number together with the type or manufacturer's reference, voltage and wattage of the lamp installed.

- (c) Schedule of escape and emergency lighting fittings installed stating location, manufacturer, type or catalogue number together with the type or manufacturer's reference, voltage and wattage of the lamp installed. For battery systems the position of the battery, its ampere hour rating and battery system rated endurance in hours shall be stated.
- (d) Records of smoke detectors, sprinklers, fire precautions.
- (e) Incoming supply details; the type of system, voltage, phases, frequency, rated current and short circuit level, with the details of the supply protection and time of operation as appropriate.
- (f) Main switchgear details; for purpose made equipment this shall include a set of manufacturers' drawings and the site layout.
- (g) Transformer, capacitor and power plant details; the leading details shall be given, for example, for transformers the V.A rating, voltages and type of cooling; and
- (h) Completion certificate, according to the Bangladesh Electricity Act.

5.6 Inspections

5.6.1 General

Regular inspections are actual part of the procedures for the maintenance of buildings. They are needed for a variety of purposes and each purpose requires a different approach if it is to be handled with maximum economy and efficiency. A more detailed inspection covering all parts of a building is needed to determine what work shall be included in cyclic and planned maintenance programme.

5.6.2 Frequency of Inspection

Inspection shall be carried out at the following frequencies:

- (a) Routine - Continuous regular observations shall be undertaken by the building user as part of the occupancy of building. Feedback resulting from this type of observation shall be recorded in record book.
- (b) General - Visual inspections of main elements shall be made annually under the supervision of suitably qualified personnel at appropriate times.
- (c) Detailed - The frequency of full inspection of the building fabric by suitably qualified personnel shall not normally exceed a 5 year period.

5.6.2.1 Inspection schedule

The preparation of a specific inspection schedule shall be formulated at the beginning. Once prepared, it shall be used for subsequent inspections.

5.6.3 Inspection of Engineering Services

Engineering services generally have a shorter life expectancy than building fabric and because of their dynamic function shall be subjected to more frequent inspections and maintenance.

Inspection of services shall be carried out for three purposes as follows.

- (a) To check if maintenance work is required,
- (b) To check if maintenance work is being adequately carried out, and
- (c) For safety reasons to comply with statutory requirements and if required, with recommendations of other relevant organizations.

The frequency of inspections for the purpose:

- (a) will depend upon types of plant and system manufacturer's recommendations and subjective judgment.
- (b) shall be carried out on an annual basis.

5.6.3.1 Method of inspection

The limited life of building services means it is important to record their residual life so that their replacement can be budgeted for, and inspection methods shall be arranged accordingly.

A checklist of items of plant to be inspected shall be considered. Detailed specifications of how inspections shall be carried out are necessary because a simple visual inspection is unlikely to show whether plant is operating correctly and efficiently.

Inspections frequently necessitate the use of appropriate instruments by competent persons. An example of this is the inspections carried out to check compliance with statutory requirements.

When instruments are used it is important that adequate training is provided in the use of the instruments and the interpretation of the results.

Records of all inspections shall be kept in suitable locker.

5.7 Maintenance of Electrical Appliances

5.7.1 Planning of Maintenance Work

If the authorized person has complete knowledge of the electrical appliances to be worked upon, then safety will be more assured. If the person attending to the job is not technically competent to handle the job then more careful planning is required before hand.

Repetitive nature of jobs involves little or no pre-planning whereas infrequent nature of jobs shall need careful planning even if the person attending the job is technically competent.

Planned routine maintenance will facilitate continued safe and acceptable operation of an electrical system with a minimum risk of breakdown and consequent interruption of supply.

As far as the electrical equipment/installations are concerned, it is not possible to lay down precise recommendations for the interval between the maintenance required. The recommendation for frequency of maintenance in this regard from the manufacturer is more relevant. The manufacturer shall be requested to specify minimum maintenance frequency under specified conditions. These intervals depend greatly upon the design of the equipment, the duty that it is called on to perform and the environment in which it is situated.

Following two types of maintenance are envisaged.

5.7.1.1 Routine maintenance

Routine maintenance of the electrical equipment goes along with the regular inspections of the equipment. Inspections shall reveal the undue damage and excessive wear to the various components. Examination of the equipment shall reveal any need for conditioning of the contact system, lubrication and adjustment of the mechanisms.

5.7.1.2 Post fault maintenance

When there is a breakdown in the system and certain parts are identified for the replacement and then the maintenance/repair of the defective part away from the operating environment is covered under post fault maintenance.

5.7.2 Guidelines for the Maintenance of Electrical Appliances

Uninterrupted and hazard free functioning of the electrical installations are the basic parameters of maintenance. The equipment shall be restored to correct working conditions. Special attention shall be paid to the items and settings that might have been disturbed during the operational phase. Loose and extraneous equipment or wiring gives rise to potential safety hazards. All covers and locking arrangements shall be properly checked and secured to achieve original degree of protection.

Guidelines to be followed for the maintenance of electrical equipment to ensure their smooth functioning are given in Appendix A of this Part.

5.8 Operating and Maintenance Manuals

The engineering services within buildings frequently are dynamic, involving complex systems of integrated plant items. Operation of such plant can require detailed knowledge and direction. Maintenance can also require extensive information to be available. It is, therefore, important to have suitable operating and maintenance manuals to provide the necessary guidance. These shall be included as part of the contractual requirements for new installations and shall ideally be prepared as reference documents for existing installations where no such information exists.

5.9 Prevention of Cracks

Cracks in buildings are of common occurrence. A building component develops cracks whenever stress in the component exceeds its strength. Stress in a building component could be caused by externally applied forces, such as dead, imposed, wind or seismic loads, or foundation settlement or it could be induced internally due to thermal movements, moisture changes, chemical action, etc.

Cracks could be broadly classified as structural or non-structural. Structural cracks are those which are due to incorrect design, faulty construction or overloading and these may endanger the safety of a building. Extensive cracking of an RCC beam is an instance of structural cracking. Non-structural cracks are mostly due to internally induced stresses in building materials and these generally do not directly result in structural weakening. In course of time, however, sometime non-structural cracks may, because of penetration of moisture through cracks or weathering action, result in corrosion of reinforcement and thus may render the structure unsafe. Vertical cracks in a long compound wall due to shrinkage or thermal movement is an instance of non-structural cracking. Non-structural cracks, normally do not endanger the safety of a building, but may look unsightly, or may create an impression of faulty work or may give a feeling of instability. In some situations, cracks may, because of penetration of moisture through them, spoil the internal finish, thus adding to cost of maintenance. It is, therefore, necessary to adopt measures of prevention or minimization of these cracks.

5.10 Repairs and Seismic Strengthening of Buildings

5.10.1 Non-structural/Architectural Repairs

The buildings affected by earthquake may suffer both non-structural and structural damages. Nonstructural repairs may cover the damages to civil and electrical items including the services in the building. Repairs to non-structural components need to be taken up after the structural repairs are carried out. Care shall be taken about the

connection details of architectural components to the main structural components to ensure their stability,

Non-structural and architectural components get easily affected/dislocated during the earthquake. These repairs involve one or more of the following.

- (a) Patching up of defects such as cracks and fall of plaster.
- (b) Repairing doors, windows, replacement of glass panes.
- (c) Checking and repairing electric conduits/ wiring.
- (d) Checking and repairing gas pipes, water pipes and plumbing services.
- (e) Re-building non-structural walls, smoke chimneys, parapet walls, etc.
- (f) Re-plastering of walls as required.
- (g) Rearranging disturbed roofing tiles.
- (h) Relaying cracked flooring at ground level; and
- (i) Redecoration - whitewashing, painting, etc.

The architectural repairs as stated above do not restore the original structural strength of structural components in the building and any attempt to carry out only repairs to architectural/non-structural elements neglecting the required structural repairs may have serious implications on the safety of the building. The damage would be more severe in the event of the building being shaken by the similar shock because original energy absorption capacity of the building would have been reduced.

5.10.2 Structural Repairs

Prior to taking up of the structural repairs and strengthening measures, it is necessary to conduct detailed damage assessment to determine:

- (a) the structural condition of the building to decide whether a structure is amendable for repair; whether continued occupation is permitted; to decide the structure as a whole or a part require demolition, if considered dangerous;
- (b) if the structure is considered amendable for repair then detailed damage assessment of the individual structural components (mapping of the crack pattern, distress location; crushed concrete, reinforcement bending/yielding, etc.). Non-destructive testing techniques could be employed to determine the residual strength of the members; and
- (c) to work out the details of temporary supporting arrangement of the distressed member so that they do not undergo further distress due to gravity loads.

After the assessment of the damage of individual structural elements, appropriate repair methods are to be carried out component wise depending upon the extent of damage. The repair shall consist of the following:

- (a) Removal of portions of cracked masonry walls and piers and rebuilding them in richer mortar. Use of non-shrinking mortar will be preferable.
- (b) Addition of reinforcing mesh on both faces of the cracked wall, holding it to the wall through spikes or bolts and then covering it, suitably, with cement mortar or micro-concrete.
- (c) Injecting cement or epoxy like material which is strong in tension, into the cracks in walls.
- (d) The cracked reinforced cement elements shall be repaired by epoxy grouting and could be strengthened by epoxy or polymer mortar application like shotcreting, jacketing, etc.

5.10.3 Seismic Strengthening

The main purpose of the seismic strengthening is to upgrade the seismic resistance of a damaged building while repairing so that it becomes safer under future earthquake occurrences. This work shall involve some of the following actions:

- (a) Increasing the lateral strength in one or both directions by increasing column and wall areas or the number of walls and columns.
- (b) Giving unity to the structure, by providing a proper connection between its resisting elements, in such a way that inertia forces generated by the vibration of the building can be transmitted to the members that have the ability to resist them. Typical important aspects are the connections between roofs or floors and walls, between intersecting walls and between walls and foundations.
- (c) Eliminating features that are sources of weakness or that produce concentration of stresses in some members. Asymmetrical plan distribution of resisting members, abrupt changes of stiffness from one floor to the other, concentration of large masses and large openings in walls without a proper peripheral reinforcement are examples of defects of this kind.
- (d) Avoiding the possibility of brittle modes of failure by proper reinforcement and connection of resisting members.

5.10.4 Seismic Retrofitting

Many existing buildings do not meet the seismic strength requirements of present earthquake codes due to original structural inadequacies and material degradation due to time or alterations carried out during use over the years. Their earthquake resistance can be upgraded to the level of the present day codes by appropriate seismic retrofitting techniques, such as mentioned in Sec 5.10.3 of this Chapter.

5.10.5 Strengthening or Retrofitting Versus Reconstruction

Replacement of damaged buildings or existing unsafe buildings by reconstruction is, generally, avoided due to a number of reasons, the main ones among them being:

- (a) higher cost than that of strengthening or retrofitting.
- (b) preservation of historical architecture, and
- (c) maintaining functional social and cultural environment.

In most instances, however, the relative cost of retrofitting to reconstruction cost determines the decision. As a thumb rule, if the cost of repair and seismic strengthening is less than about 50 percent of the reconstruction cost, the retrofitting is adopted. This shall also require less working time and much less dislocation in the living style of the population. On the other hand reconstruction may offer the possibility of modernization of the habitat and may be preferred by well-to-do communities.

Cost-wise the building construction including the seismic code provisions in the first instance, works out the cheaper in terms of its own safety and that of the occupants. Retrofitting an existing inadequate building may involve as much as 4 to 5 times the initial extra expenditure required on seismic resisting features. Repair and seismic strengthening of a damaged building may even be 5 to 10 times as expensive. It is, therefore, very much safe as well as cost-effective to construct earthquake resistant buildings at the initial stage itself according to the relevant seismic codes.

5.11 Maintenance Manual

The Consultant/Engineer shall prepare a “Maintenance Manual” prior to handing over of the completed project and furnish this to the Employer, which must contain following items.

- (a) As-built drawings for the completed project.
- (b) Sources of all items of work including materials, furnishes equipment and fixed furniture, containing names and addresses of suppliers, catalogue numbers, technical information & specifications and warranty documents for respective items.
- (c) Frequency of routine preventive maintenance and the procedure thereof, including information on available local and foreign after-sales service sources.
- (d) Corrective maintenance procedure and sources of available.

5.12 Related Appendix

Appendix A Guidelines for Maintenance of Electrical Equipment

PART VII
Appendix A**Guidelines for Maintenance of Electrical Equipment**

- A.1** In case of electrical appliances, manufacturer's instructions for the usage and maintenance of the equipment should be strictly followed.
- A.2** The detailed/working drawings of all the components of electrical installations should always be available with the maintenance unit. Following records should be available.
- (a) Manufacturer's name.
 - (b) Nameplate of the equipment and its salient features such as capacity, rating etc.
 - (c) Manufacturer's recommendations regarding availability/usage of spare parts.
 - (d) Manufacturer's recommendations for periodical maintenance and post fault maintenance.
 - (e) Details of the maintenance operations performed in the past.
- A.3** Care should be taken while selecting replacement parts. The spare parts should be correct and suitable, preferably as recommended by the manufacturer of the installation. During the placement of order for the supply of spare parts, nameplate particulars and serial number should be quoted.
- A.4** The space where the equipment is kept should be clean and properly ventilated. Equipment should not be disturbed needlessly. Before cleaning, the equipment should be made dead. For internal cleaning a section cleaner should be used.
- A.5** Covers and doors should not be left open unnecessarily during maintenance. Afterwards they should be promptly and correctly closed and locked.
- A.6** Before removing the covers and connections, all covers and cable terminations should be marked to ensure correct replacements. Disturbed connections and temporary connections should be marked to facilitate re-connection. Temporary connections and markings should be removed before the installation is put to use.
- A.7** Those connections which have not been disturbed should also be checked for soundness and overheating.
- A.8** All insulations should be regularly checked. Solid insulations should be checked for cracks and other defects. Fibrous and organic insulations should be checked for sign of blistering, delamination and mechanical damage. For insulating oils the interval between tests should be carried out as per the recommendations of the manufacturer and keeping the adverse environmental conditions in mind.

-
- A.9** It should be ensured that the earthing connections are sound and all contact screws are tight.
- A.10** During the examination of interlocks it is necessary to take precautions to prevent danger to plant or persons in the event of malfunction or inadvertent operation. A person responsible for checking and maintaining any interlock system should have thorough knowledge of the extent, nature and function of the interlock.
- A.11** If the equipment is ventilated then it should be ensured that the airflow is smooth and not restricted. If filters are provided, they should be cleaned or replaced as necessary.
- A.12** The standby system for tripping and closing supplies should always be kept in good order. Indicators and alarms should be maintained in time with the manufacturer's instructions.
- A.13** Tools, spares and instruments should be stored near to the installation. These should be regularly checked against an inventory.
- A.14** Before the start of maintenance of the circuit switches it should be ensured that all incoming and outgoing main auxiliary circuits are dead and remain so during the maintenance. Overheating of the circuit switches is the root cause for faults. Overheating may be caused by inadequate ventilation, overloading, loose connection, insufficient contact force and malalignment.
- A.15** Some circuit breakers are not intended to be maintained, such as miniature circuit breakers (MCBs). Such items should not be dismantled for maintenance. These should be renewed periodically.
- A.16** For the maintenance of fuses periodical inspection should be done for correct rating, security, overheating and correct location/orientation. Element of renewable fuses should be renewed when the deterioration is apparent. The availability and correct replacement of fuse links should be ensured.
- A.17** If a fuse link of certain rating has failed and is replaced, then all fuse-links of same rating apparently subjected to the fault should be destroyed and replaced by new fuse links.
- A.18** In order to be reasonably sure that circuit breaker is capable of operation when required, these should be tripped and reclosed at regular intervals. Tripping should be proved manually and where possible electrically via the protective relay contacts. The leakage of oil, sign of corrosion, and any unusual smell which may indicate over-heating should be detected through inspections.

- A.19** Timing devices are mostly designed for specialist maintenance. These should not be dismantled for maintenance or overhaul purposes unless specifically recommended by the manufacturers'. Actual timing periods should be verified with set values and application requirements.
- A.20** In case of cable boxes and terminations, security of mounting and earthing should be examined. Exposed tails should be inspected for good conditions of insulation and freedom from moisture.
- A.21** Battery cells should be inspected for shedding of active material, sedimentation and buckling of plates. Level of electrolyte should be regularly checked and the level should be corrected with distilled water.

PART VIII
Chapter 1

Electrical and Electronic Engineering Services for Buildings

1.1 Introduction

1.1.1 Scope

The provisions of the Code presented in this Chapter, cover the Electrical and Electronic Engineering Services for Buildings to ensure that the related installation work becomes perfect and safe for the persons residing in and around the building. The term safe means safe for the persons and safe for the properties.

Provisions of the Specifications are to set minimum standards for Electrical and Electronic Engineering Installations in various Occupancy categories of buildings, as described in Part 3 of this Code, including annexes and premises. All the systems and equipment intended for the supply of normal power and standby power to all these places are covered by the provisions of this Code.

The provisions of the Code for various Electrical and Electronic Engineering systems and/or installations for the buildings include, but not limited to:

- (a) Lighting and illumination.
- (b) Fans, cooling and heating.
- (c) Normal and standby power supply.
- (d) Supply system and feeder for lifts/escalator/moving walk, including protection.
- (e) Cable television distribution.
- (f) Electronic access control.
- (g) Burglar alarm/CCTV monitoring/security.
- (h) Electrical cables/conductors and equipment.
- (i) Switches, sockets, other accessories.
- (j) Cables and conductors in a building that connect to the supply of electricity.
- (k) Electrical protection system.
- (l) Earthing system of an electrical installation.
- (m) Lightning protection of a building and its electrical installation.
- (n) Fire alarm.
- (o) Multi-media communications, data communications and telecommunications.

Electrical wiring/cabbling form a major part in the above mentioned installation works. Electrical wiring/cabbling must be reasonably safe to persons and property. Installations, alteration, or extension of Electrical wiring/cabbling systems conforming to the provisions of this Code shall be deemed to be reasonably safe to persons and property.

The provisions of the Code in this Chapter do not cover Installations in ship, water craft, railway rolling stock, aircraft, or automotive vehicles and recreational vehicles,

1.1.2 Designing an Electrical and Electronic Engineering Installations in Buildings and Related Structures

The provisions of the Code presented in this Section are not meant to provide adequate information to design Electrical and Electronic Engineering Installations and Systems in Buildings and related structures. These should not be taken to be adequate or complete for the efficient design work of installations.

Such design work, the required features, detailed technical specifications, schedule of items etc., should be obtained through the services of an engineer adequately qualified in this area. Applications of energy efficient appliances should be kept in mind while preparing electrical design of a building or related installations.

1.1.3 Terminology and Definitions

This Section provides an alphabetical list of the terms used in and applicable to this Chapter of the Code. In case of any conflict or contradiction between a definition given in this Section and that in Part 1, the meaning provided in this Section shall govern for interpretation of the provisions of this Chapter.

ACCESSORY	A device associated with current using equipment or with the wiring of an installation; for example, a switch, a plug, a socket outlet, a lamp holder, or a ceiling rose.
ALIVE	See LIVE.
APPARATUS	Apparatus means Energy Efficient Apparatus. Electrical apparatus including all machines, appliances and fittings in which conductors are used or of which they form a part.
APPLIANCE	Appliance means Energy Efficient Appliance. An item of electric current using equipment other than a luminaries or an independent motor.
BDB	Branch-Distribution Board located in the same floor of a building and connected to one of the SDBs in the same floor.

BRANCH CIRCUIT, APPLIANCE	A branch circuit supplying energy to one or more outlets to which appliances are to be connected; such branch circuits do not have any permanently connected lighting fixtures except those that are integral parts of the appliances themselves.
BRANCH CIRCUIT, GENERAL PURPOSE	A branch circuit that supplies a number of outlets for lighting and/or appliance.
BRANCH CIRCUIT, INDIVIDUAL	A branch circuit that supplies only one utilization equipment.
BUNCHED	Cables are said to be bunched when two or more are either contained within a single conduit, duct, ducting, or trunking or, if not enclosed, are not separated from each other.
CABLE	PVC insulated copper cables having copper cross section of 1 mm ² and above. A length of single insulated conductor (solid or stranded), or two or more such conductors, each provided with its own insulation. The insulated conductor or conductors may or may not be provided with an overall mechanical protective covering.
CEILING ROSE	A ceiling rose is used for terminating the point wiring for a Light or a Fan in the ceiling. It has brass terminals in which incoming cables are terminated using brass screws on the terminals and the outgoing flexible cables get connection through the screw connections.
CIRCUIT	An assembly of electrical equipment supplied from the same origin and protected against overcurrent by the same protective device.
SUB CIRCUIT, FINAL CIRCUIT	An outgoing circuit connected to one way of a distribution board or a fuse board and intended to supply electrical energy, to one or more points, to current using appliances without the intervention of a further distribution fuse board other than a one-way board. It includes all branches and extensions derived from that particular way in the distribution board or fuse board.

CIRCUIT BREAKER	A device designed to open and close a circuit by non-automatic means and to open the circuit automatically on a predetermined overcurrent, without injury to itself when properly applied within its rating.
CIRCUIT BREAKER	A device used to break a circuit during over current or short circuit condition. An LV Circuit Breaker is used in a low voltage distribution system and an HV Circuit Breaker is used in a high voltage distribution system.
CORD, FLEXIBLE CABLE	A flexible cable having large number of strands of conductors of small cross-sectional area with a soft PVC insulation. Two flexible cords twisted together may be termed as twin flexible cord. However, some flexible cords are made following the style of a twin core PVC insulated copper cables but much soft and flexible.
CUTOUT	Any appliance for automatically interrupting the transmission of energy through a conductor when the current rises above some predetermined value. A cutout contains a part for holding either fuse wire (rectangular cross section type) or a part for holding tubular fuse (cylindrical body rectangular cross section type). (see FUSE)
DB	Distribution Board. This may be the box where the main incoming cable enters and terminates from the main service feed connection. The SDBs get feed from a DB.
DEMAND FACTOR	The ratio of the maximum demand of a system, or part of a system, to the total connected load of the system or the part of the system under consideration.
DUCT	A closed passageway formed underground or in a structure and intended to receive one or more cables which may be drawn in.
EARTH	The conductive mass of the earth, whose electric potential at any point is conventionally taken as zero.
EARTH ELECTRODE	A metal plate, pipe or other conductor electrically connected to the general mass of the earth.
EARTH LEAD WIRE	The final conductor by which the connection to the earth electrode is made.

EARTH CONTINUITY CONDUCTOR (ECC)	The conductor, including any clamp, connecting to the earthing lead or to each other, those parts of an installation which are required to be earthed. It may be in whole or in part the metal conduit or the metal sheath or armour of the cables, or the special continuity conductor of a cable or flexible cord incorporating such a conductor. ECCs of appropriate size must run from an MDB to its DBs, from a DB to its corresponding SDBs, from an SDB to the Switch Boards under this SDB, from an SDB to the BDBs if there are any, from a BDB to the Switch Boards under this BDB, from an SDB or a BDB to the Sockets under this SDB or BDB.
EDB	Emergency Distribution Board. This may be the box where the main incoming cable from the Emergency or Standby Generator Panel enters and. The ESDBs get feed from a EDB.
EFDB	Emergency Floor Distribution Board located in each of the floors of a multistoried building. The EDBs get feed from EFDB.
ENGINEER-IN- CHARGE	An engineer responsible for implementation/execution of the work of a building or a project. Such an engineer is expected to have significant knowledge in Electrical Engineering, Electrical Construction, Measurement, Codes and Practices of such work and availability of different materials needed for the construction.
FDB	Floor Distribution Board located in each of the floors of a multistoried building. The DBs get feed from FDB.
FUSE	A device that, by the fusion of one or more of its specially designed and proportioned components, opens the circuit in which it is inserted when the current through it exceeds a given value for a sufficient time. Fuse is generally made of fusible wires of appropriate ratings which is either mounted inside glass tubes or porcelain tubes or on a two terminal cutout.
FUSE SWITCH	A composite unit, comprising a switch with the fuse contained in, or mounted on, the moving member of the switch.
LIGHTING FITTING	A device for supporting or containing a lamp or lamps (for example, fluorescent or incandescent) together with any holder, shade, or reflector; for example, a bracket, a pendant with ceiling rose, or a portable unit.

INSULATION	Suitable non-conducting material, enclosing, surrounding or supporting a conductor. Usually PVC, polymer, specially treated rubber.
LIVE	Electrically charged so as to have a potential different from that of earth. Also known as ALIVE.
LUMINAIRE	A complete light fitting consisting of lamp, holder, starting gears, reflectors, housing and mounting accessories.
LT / LV and HT/ HV	LT or LV in this document indicates 230 Volt single phase and 400 volt 3 phase. HT or HV in this document indicates 11 kV Line to line 3 phase system.
MDB	Main Distribution Board. This is the distribution box where the main incoming cable enters and terminates from the main service feed connection of a large building. The FDBs get feed from MDB.
OVER-CURRENT	A current exceeding the rated current. For conductors, the rated value is the nominal current carrying capacity.
PANEL BOARD	A single panel or a group of panel units designed for assembly in the form of a single panel including buses, automatic overcurrent devices, and with or without switches for the control of light, heat, or power circuits, designed to be placed in a cabinet or cutout box placed in or against a wall or partition and accessible only from the front.
PLUG	A device carrying metallic contacts in the form of pins intended for engagement with corresponding socket contacts and arranged for attachment to a flexible cord or cable. A plug may contain tubular fuse inside it although some plugs do not contain fuse.
POINT (in wiring)	A termination of the fixed wiring intended for the connection of current using equipment e.g., a Light, a fan, an exhaust fan.
SDB	Sub- Distribution Board located in the same floor of a building and connected to the DB. The BDBs get feed from SDB.
SERVICE	The conductors and equipment required for delivering energy from the electric supply system to the wiring system of the premises served.

SWITCH	A manually operated device for closing and opening or for changing the connection of a circuit. A 5A SPST switch is used for the control of a Light or Fan point. A 5A SPDT switch is also used for the control of a Light or Fan point.
SWITCHBOARD	An assemblage of switchgear with or without instruments; the term, however, does not apply to a group of local switches on a final sub-circuit where each switch has its own insulating base.
SWITCHGEAR	Main switches cutouts or fuses, conductors and other apparatus in connection therewith, used for the purpose of controlling or protecting electrical circuits or machines or other current using appliances.

1.1.4 Voltage Ratings

The provisions of the Code specified in this Chapter covers installations utilizing nominal voltage not exceeding 415 V AC between conductors or 240 V AC to earth. The nominal voltage in Bangladesh is 230 volts AC single phase and 400 volts AC 3 phase.

1.2 Lighting and Illumination

1.2.1 Determination of Illumination Levels for Different Application (Principle of Lighting)

The essential features of an efficient lighting system are:

- (a) Visual comfort through adequate illumination of the working surface,
- (b) Prevention of glare,
- (c) Avoidance of shadows, and
- (d) Ease of maintenance.

The design of a lighting system shall involve:

- (a) careful planning of the brightness and colour pattern within both the working areas and the surroundings so that attention is drawn naturally to the important areas, so that details can be seen quickly and accurately, and so that the appearance inside the room is free from any sense monotony,
- (b) use of directional lighting to assist perception of task detail,
- (c) controlling direct and reflected glare from light sources to eliminate visual discomfort,

- (d) minimizing flicker from certain types of lamps and paying attention to the colour rendering properties of the light,
- (e) the correlation of lighting throughout the building to prevent excessive differences between adjacent areas, so as to reduce the risk of accidents, and
- (f) the installation of emergency lighting systems, wherever necessary.

The general impressions associated with different illuminance and colour appearances of light are shown in Table 8.1.1. The various colour rendering groups with examples of use are presented in Table 8.1.2.

Table 8.1.1: General Impressions Associated with Different Illuminance and Colour Appearances

Illuminance (lux)	Associated Impression (Colour Appearance)		
	Warm	Intermediate	Cool
≤ 500	Pleasant	Neutral	Cool
500 – 1000	Pleasant to Stimulating	Neutral to Pleasant	Cool to Neutral
1000 – 2000	Stimulating	Pleasant	Neutral
2000 – 3000	Stimulating to Unnatural	Pleasant to Stimulating	Neutral to Pleasant
≥ 3000	Unnatural	Stimulating	Pleasant

Table 8.1.2: Lamp Colour Rendering Groups

Colour rendering Group	Range of Index R_a	Colour Appearance	Examples of Use
1	$R_a \geq 85$	Cool	Textile industries, paint and printing industries
		Intermediate	Shops, hospitals
		Warm	Homes, hotels, restaurants
2	$70 \leq R_a < 85$	Intermediate	Offices, schools, department store, fine industrial work
3	$40 \leq R_a < 70$		Interiors where colour rendering is of comparatively minor importance

Note: Certain applications, e.g. colour matching, may be extremely critical with regard to the colour rendering properties of the lamps used. Here, the minimum colour rendering index used shall be 90.

1.2.2 Planning the Brightness Pattern

The brightness pattern seen within an interior is composed of three parts.

- (a) Brightness of the task itself.
- (b) Brightness of the immediate background of the task and
- (c) Brightness of the general surroundings of walls, ceiling, floor, equipment, furnishing etc.

1.2.2.1 The illumination of all work areas within a building shall be a minimum of 150 lux.

1.2.2.2 Where work takes place over the whole utilizable area of a room, the general illumination over that area shall be reasonably uniform and the diversity ratio of minimum to maximum illumination shall not be less than 0.7. This diversity ratio does not however take into account of the effects of any local lighting provided for specific tasks.

1.2.2.3 When the brightness appropriate to an occupation has been determined, the brightness of the other parts of the room shall be planned to give proper emphasis to visual comfort and interest. The recommended brightness ratios are shown in Table 8.1.3.

Table 8.1.3: Brightness Ratios between Task, Adjacent Sources and Surroundings

<p>For high task brightness (above 100 cd/m²)</p> <p>Maximum ratio between task brightness and the adjacent sources like table tops</p> <p>Maximum ratio between task brightness and illumination of the remote areas of the room not being used as work areas</p>	<p>3 to 1</p> <p>10 to 1</p>
<p>For low and medium task brightness (below 100 cd/m²)</p>	<p>The task must be brighter than both the background and the surroundings; the lower the task brightness, the less critical is the relationship.</p>

1.2.3 Lighting Calculations

1.2.3.1 In order to determine the necessary number of lamps and luminaires for a specified illumination level or the average illuminance obtained from a particular lighting design, the Lumen Method of calculation shall be employed.

1.2.3.2 Unless the reflection factors are known to the lighting designer, the triplet 0.7/0.5/0.3 for the reflectance of ceiling, walls and working plane respectively shall be used for offices and the triplet 0.7/0.5/0.1 for other premises. Typical reflection factors of smooth coloured surfaces are given in Table 8.1.4.

Table 8.1.4: Reflection Factors of Smooth Coloured Surfaces

Colour	Reflection Factor	Colour	Reflection Factor
Flat white	0.75 – 0.85	Light green	0.40 – 0.50
Ivory	0.70 – 0.75	Grey	0.30 – 0.50
Buff	0.60 – 0.70	Blue	0.25 – 0.35
Yellow	0.55 – 0.65	Red	0.15 – 0.20
Light tan	0.45 – 0.55	Dark brown	0.10 – 0.15

1.2.4 Recommended Illumination Values

The recommended values of illumination required for buildings of different occupancies, based on activity, are given in Tables 8.1.5 to 8.1.14. The initial illuminance should be higher than the recommended value as the illuminance drops below this value by the end of the cleaning and replacing period. A gradual transition (rather than a sudden change) of brightness from one portion to another within the field of vision is recommended to avoid or minimize glare discomfort.

1.2.5 Artificial Lighting to Supplement Daylight

Supplementary lighting shall be used when illumination from daylight falls below 150 lux on the working plane. For supplementary artificial lighting when daylight availability becomes insufficient, cool daylight fluorescent tubes with semi-direct luminaires are recommended. To ensure a good distribution of illumination, the mounting height should be between 1.5 and 2.0 m above the work plane with a separation of 2.0 to 3.0 m between the luminaires.

1.2.6 Selection of Appropriate Light Fittings

1.2.6.1 Light fitting

An electric lamp and its fitting accessories, reflector, diffuser, mounting brackets, suspenders etc., shall be regarded as one unit. During design, an appropriate type of light fitting shall be selected to match the requirement of desired distribution of light. While selecting light fittings having focus or aiming arrangements which enable the light distribution to be varied by adjustment of the lamp position, care should be taken to select the appropriate type of fitting with appropriate beam to serve the aimed lighting applications.

1.2.6.2 Classification of light fittings

Light fittings may be classified into five categories according to the proportion of the total light output in the lower hemisphere. These are:

- Direct fittings, giving 90-100 percent light downwards
- Semi-direct fittings, giving 60-90 percent downwards
- General diffusing fittings, giving 40-60 percent light downwards
- Semi-indirect fittings, giving 10-40 percent light downwards
- Indirect fittings, giving 0-10 percent light downwards

(a) Direct fittings: Direct fittings shall be used in situations where efficiency of illumination is the major criterion, while contrast of the light source with the surroundings, shadows, and direct/reflected glare may be considered to be of relatively minor importance.

(b) Semi-direct fittings: Semi-direct fittings shall be used in areas where it felt that the reduction of contrast resulting from the small indirect component of light directed towards the ceiling shall be sufficient for the purpose.

(c) General diffusing fittings: General diffusing fittings shall be used where, in addition to a substantial indirect component of light aiding materially to the diffused character of the general illumination, an upward component providing a brighter background against which to view the luminance, especially for interiors with light-colored ceiling and walls, is desirable.

Table 8.1.5: Recommended Values of Illumination for Residential Buildings

Area or Activity	Illuminance (lux)	Area or Activity	Illuminance (lux)
Dwelling Houses		Hotels	
Bedrooms		Entrance halls	150
General	70	Reception and accounts	300
Bed-head, Dressing table	250	Dining rooms (tables)	150
Kitchens	200	Lounges	150
Dining rooms (tables)	150	Bedrooms	
Bathrooms		General	100
General	100	Dressing tables, bed heads, etc.	250
Shaving, make-up	300	Writing rooms (tables)	300
Stairs	100	Corridors	70
Lounges	100	Stairs	100
Garages & Porches	100	Laundries	200

Area or Activity	Illuminance (lux)	Area or Activity	Illuminance (lux)
Basement Car Park	100	Kitchens	
Porches, Entrances	70	Food stores	100
Sewing and darning	600	Working areas	250
Reading (casual)	150	Goods and passenger lifts	70
Home work and sustained reading	300	Cloak-rooms and toilets	100
		Bathrooms	100
		Above mirror in bathrooms	300

Table 8.1.6: Recommended Values of Illumination for Educational Buildings

Area or Activity	Illuminance (lux)	Area or Activity	Illuminance (lux)
School and College Assembly halls		Offices	300
General	150	Staff rooms and common rooms	150
When used for examinations	300	Corridors	100
Platforms	300	Stairs	100
Class and Lecture Rooms		Gymnasium	100
Desks	300	General	150
Black boards	300	Matches	300
Embroidery and sewing rooms	500	Library	see Table 8.1.8
Laboratories	350	Living quarters	see Table 8.1.5
Art rooms	400		

Table 8.1.7: Recommended Values of Illumination for Health Care Buildings

Area or Activity	Illuminance (lux)	Area or Activity	Illuminance (lux)
Hospitals and Clinics		Hospitals and Clinics (contd.)	
Reception and waiting rooms	150	Doctor's examination rooms	150
Outpatient department	150	Radiology departments	100
Wards		Casualty	150
General	150	Stairs and corridors	100
Beds	150	Dispensaries	250
Operating theatres			
General	300		
Tables (with adjustable operation lamp lighting)			
Minor	2000		
Major	5000		

Table 8.1.8: Recommended Values of Illumination for Assembly Buildings

Area or Activity	Illuminance (lux)	Area or Activity	Illuminance (lux)
Cinemas		Theatres	
Foyers	150	Foyers	150
Auditorium	100	Auditorium	70
Corridors	100	Corridors	90
Stairs	150	Stairs	150
Libraries		Indoor Sports Centre	
Shelves (stacks)	150	Halls	200
Reading rooms (newspapers and magazines)	200	Swimming pools	250
Reading tables	300	Lawn or table tennis, badminton, volley ball	
Book repair and binding	300	Tournament	300
Cataloguing, sorting and stock rooms	150	Club	200
Museums and Art Galleries		Recreational	150
Museums		Shooting ranges	
General	200	On target	300
Displays	special lighting	Firing point	200
Art galleries		Range	100
General	250	Football	500
Paintings	250		
Restaurant			
Dining rooms	150		
Cash desks	300		
Self-carrying counters	300		
Kitchens	200		
Cloak-rooms and toilets	100		

Table 8.1.9: Recommended Values of Illumination for Business and Commercial Buildings

Area or Activity	Illuminance (lux)	Area or Activity	Illuminance (lux)
Airport Building		Doctor's Surgeries	
Reception areas (desks)	300	Waiting rooms and consulting rooms	150
Baggage, customs and immigration halls	300	Corridors	70
Circulation areas, lounges	200	Stairs	100
Banks		Eyesight testing (acuity) wall charts and near vision types	450
Counter, typing and accounting book areas	300	Jewellery and Watch-Making	
Public areas, lobby	150	Fine processes	700
Offices	200	Minute processes	3000
Book Binding		Gem cutting, polishing and setting	1500
Pasting, punching and stitching	200	Laundries and Dry-Cleaning Works	
Binding and folding and miscellaneous machines	300	Receiving, sorting, washing, drying, ironing (calendaring) and dispatch	200
Finishing, blocking and inlaying		Dry-cleaning and bulk machine work	200
Dental Surgeries		Fine hand ironing, pressing, inspection, mending and spotting	300
Waiting rooms	300	Offices (contd.)	
Surgeries	150	Stairs	100
General	300	Lift landings	150
Chairs	special lighting	Telephone exchanges	
Laboratories	300	Manual exchange rooms (on desk)	200
Offices		Main distribution frame room	150
Entrance lobby and reception areas	150	Shops and Stores	
Conference rooms and executive offices	300	General areas	150 to 300
General offices	300	Stock rooms	200
Business machine operation	450	Display windows	500
Drawing office			
General	300		
Boards and tracing	450		
Corridors and lift cars	70		

Table 8.1.10: Recommended Values of Illumination for Industrial Buildings and Processes

Area or Activity	Illuminance (lux)
Aircraft Factories and Maintenance Hangars	
Stock parts productions	450
Drilling, riveting, screw fastening, sheet aluminium layout and template work, wing sections, coving, welding, sub-assembly, final assembly and inspection	300
Maintenance and repair (hangars)	300
Assembly Shops	
Rough work, for example frame assembly and assembly of heavy machinery	150
Medium work, for example machined parts, engine assembly	300
Fine work, for example radio and telephone equipment, typewriter and office machinery assembly	700
Very fine work, for example assembly of very small precision mechanisms and instruments	1500
Automobile Manufacturing	
Frame assembly	200
Chassis assembly line	300
Final assembly and inspection line	600

Table 8.1.10: Recommended Values of Illumination for Industrial Buildings and Processes (contd.)

Area or Activity	Illuminance (lux)
Body Manufacturing	
Parts	200
Assembly	300
Finishing and inspection	700

Table 8.1.10: Recommended Values of Illumination for Industrial Buildings and Processes (contd.)

Area or Activity	Illuminance (lux)
Automobile Service Garages	
Repairs	250
Active traffic areas	100
Storage	25
Bakeries	
General working area	150
Decorating and icing	250
Breweries and Distilleries	
General working areas	150
Brew house, bottling and canning plants	200
Bottle inspection	special lighting
Carpet Factories	
Winding and beaming	200
Designing, Jacquard card cutting, setting pattern, tufting, topping, cutting, hemming and fringing	300
Weaving, mending and inspection	450
Chemical Works	
Hand furnaces, boiling tanks, stationary driers, stationary and gravity crystallizers	150
Mechanical furnaces, evaporators, filtration, mechanical crystallizers, bleaching	200
Tanks for cooking, extractors, percolators	200

Table 8.1.10: Recommended Values of Illumination for Industrial Buildings and Processes (contd.)

Area or Activity	Illuminance (lux)
Chocolate and Confectionery Factories	
Mixing, blending and boiling	150
Chocolate husking, winnowing, fat extraction, crushing and refining, feeding, bean cleaning, sorting, milling and cream making	200
Hand decorating, inspection, wrapping and packing	300
Clay Products and Cements	
Grinding, filter presses, kiln rooms moulding, pressing, cleaning and trimming	150
Enameling	150
Colour and glazing - rough work	400
Colour and glazing - fine work	750
Clothing Factories	
Matching-up	450
Cutting, sewing	
Light	300
Medium	450
Dark	700
Inspection	
Light	450
Medium	1000
Dark	1500
Hand Tailoring	
Light	450
Medium	1000
Dark	1500
Pressing	300

Table 8.1.10: Recommended Values of Illumination for Industrial Buildings and Processes (contd.)

Area or Activity	Illuminance (lux)
Dairies	
General working areas	200
Filling and bottle inspection	450
Cooling equipment	150
Laboratories	450
Pasteurizers	150
Separators	150
Electrical Industries	
Impregnating	250
Winding and insulating	500
Assembly works	
Fine	500
Very fine	750
Testing	500
Electricity Generating Stations (Indoor Locations)	
Turbine halls	150
Auxiliary equipment, battery rooms, blowers, auxiliary generators, switchgear and transformer chambers	150
Boiler house (including operating floors) platforms, coal conveyors, pulverizers, feeders, precipitators, soot and slag	100 to 150
Boiler house and turbine house	150
Basements	100
Conveyor house, conveyor gantries and junction towers	80 to 100
Emergency lighting - all areas	30
Control rooms	
Vertical control panels	200 to 300
Control desks	300
Rear of control panels	150
Switch houses	150

Table 8.1.10: Recommended Values of Illumination for Industrial Buildings and Processes (contd.)

Area or Activity	Illuminance (lux)
Electricity Generating Stations (Outdoor Locations)	
Switchyard	70
Conveyors	70
Fuel oil delivery headers	70
Oil storage tanks	70
Cat-walks	70
Platforms, boiler and turbine decks	70
Transformer and outdoor switchgear	100
Emergency lighting - all areas	50
Flour Mills	
Rolling	150
Sifting	150
Packing	150
Purifying	150
Product control	300
Cleaning screens, man lifts, aisleways and walkways, bin checking	100
Forge Shops and Foundries	
Forge shop	150
Annealing (furnaces)	150
Cleaning	100
Core making (fine)	300
Core making (medium)	150
Grinding and chipping	200
Inspection (fine)	1000
Inspection (medium)	300
Moulding (medium)	300
Moulding (large)	150
Pouring	150
Sorting	200
Cupola	100
Shake out	150

Table 8.1.10: Recommended Values of Illumination for Industrial Buildings and Processes (contd.)

Area or Activity	Illuminance (lux)
Garages	
Parking areas (interior)	70
Washing and polishing, greasing, general servicing and pits	200
Gas Works	
Retort houses, oil gas plants, purifiers, coke screening and coke handling plants (indoor)	70
Governor, meter, compressor, booster and exhaustor houses	100
Open type plants	
Cat-walks	20
Platforms	50
Glass Works	
Furnace rooms, bending, annealing lehrs	100
Mixing rooms, forming (blowing, drawing, pressing and rolling)	150
Cutting to size, grinding, polishing and toughening	200
Finishing (bevelling, decorating, etching and silvering)	300
Brilliant cutting	
General	200
Fine	500
Inspection, etching and decorating	500
Glove Making	
Pressing, knitting, sorting and cutting	300
Sewing	
Light	300
Medium	450
Dark	700
Inspection	
Light	450
Medium	1000
Dark	1500

Table 8.1.10: Recommended Values of Illumination for Industrial Buildings and Processes (contd.)

Area or Activity	Illuminance (lux)
Hosiery and Knitwear	
Circular and flat knitting machines, universal winders, cutting out, folding and pressing	300
Lock-stitch and overlocking machines	
Light	300
Medium	450
Dark	700
Mending	1500
Examining and hand finishing, light, medium and dark	700
Linking or running on	450
Iron and Steel Works	
Manufacturing by open hearth	
Stock yard	20
Charging floor	100
Slag pits	100
Control platforms	100
Mould yard	25
Hot top	100
Hot top storage	100
Stripping yard	100
Scrap stockyard	20
Mixer building	100
Calcining building	50
Rolling mills	
Blooming, slabbing, hot strip, hot sheet	100
Cold strip, plate	150
Pipe, rod, tube, wire drawing	200
Merchant and sheared plate	100

Table 8.1.10: Recommended Values of Illumination for Industrial Buildings and Processes (contd.)

Area or Activity	Illuminance (lux)
Tin plate mills	
Tinning and galvanizing	200
Cold strip rolling	200
Motor room, machine room	150
Sheet metal works	
Miscellaneous machines, ordinary bench work	200
Pressing, folding, stamping, shearing, punching and medium bench work	200
Tin plate and galvanized sheet inspection	500
Structural Steel Fabrication	
Fabrication and general work	150
Marking and cutting	300
Plating shops	
Vat, baths, buffing and polishing	200
Final buffing and polishing	500
Leather Manufacturing	
Cleaning, tanning and stretching, vats	150
Cutting, fleshing and stuffing	200
Finishing and scarfing	200
Machine Shops	
Rough bench and machine work	150
Medium bench and machine work, ordinary automatic machines, rough grinding medium buffing and polishing	300
Fine bench and machine work, fine automatic machines, medium grinding, fine buffing and polishing	700
Extra fine bench and machine work, grinding fine work	1000

Table 8.1.10: Recommended Values of Illumination for Industrial Buildings and Processes (contd.)

Area or Activity	Illuminance (lux)
Paint Works	
General, automatic processes	200
Special batch mixing	450
Colour matching	700
Paper Manufacturing	
Beaters, grinding, calendaring	150
Finishing, cutting, trimming, paper making machines	200
Hand counting, wet end of paper machine	350
Paper machine reel, paper inspection and laboratories	500
Rewinder	500
Paper box manufacturing	200
Pharmaceuticals and Fine Chemical Works	
Raw material storage	200
Grinding, granulating, mixing and drying, tableting, sterilizing, preparation of solutions, filling, labelling, capping, wrapping and cartoning	300
Control laboratories and testing	300
Fine chemical processing	200
Fine chemical finishing	300
Printing Industries	
Photo-engraving	
Block-making, etching and staging	200
Finishing, routing and proofing	300
Masking and tint laying	300
Colour Printing	
Inspection area	700

Table 8.1.10: Recommended Values of Illumination for Industrial Buildings and Processes (contd.)

Area or Activity	Illuminance (lux)
Type foundries	
Matrix making, dressing type	250
Front assembly and sorting	200
Hand casting	300
Machine casting	200
Printing plants	
Machine composition and imposing stones	200
Presses	300
Composition room	450
Proof reading	300
Colour inspection and appraisal	1000
Electrotyping	
Block-making, electroplating, washing and baking	200
Moulding, finishing and routing	300
Rubber Tyre and Tube Manufacturing	
Stock preparation	
Plasticating, milling	100
Calendering	150
Fabric preparation	
Stock cutting, bead building	250
Tube tubing machines	250
Tread tubing machines	250
Tyre building	
Solid tyre	150
Pneumatic tyre	250
Curing department	

Table 8.1.10: Recommended Values of Illumination for Industrial Buildings and Processes (contd.)

Area or Activity	Illuminance (lux)
Tubing curing, casing curing	350
Final Inspection	
Tube, casing	1000
Wrapping	200
Shoe Manufacturing (Leather)	
Cutting and stitching	
Cutting tables	450
Marking, buttonholing skiving, sorting and counting	450
Stitching	
Light materials	300
Dark materials	1000
Making and finishing	
Nailers, sole layers, welt beaters and scarfers, trimmers, welters, lasters, edge setters, sluggers, randers, wheelers, treers, cleaning, spraying, buffing, polishing, embossing	600
Shoe Manufacturing (Rubber)	
Washing, coating, mill run compounding	100
Varnishing, vulcanizing, calendering, upper and sole cutting	300
Sole rolling, lining, making and finishing process	500
Soap Factories	
Kettle houses and ancillaries, glycerine evaporation and distillation and continuous indoor soap making	
General areas	150
Control panels	200 to 300
Batch or continuous soap cooling, cutting and drying, soap milling and plodding	

Table 8.1.10: Recommended Values of Illumination for Industrial Buildings and Processes (contd.)

Area or Activity	Illuminance (lux)
General areas	150
Control panels and key equipment	200 to 300
Soap stamping, wrapping and packing, granules making, granules storage and handling, filling and packing granules	
General areas	150
Control panels and machines	200 to 300
Edible products processing and packing	200
Textile Mills (Cotton)	
Bale breaking and picking	150
Carding and drawing	200
Slubbing, roving, spinning, spooling	200
Beaming and slashing on comb	
Grey goods	200
Denims	300
Weaving	
Patterned cloth and fine counts, light	300
Patterned cloth and fine counts, dark	500
Plain grey cloth	200
Cloth inspection	700
Textile Mills (Silk and Synthetics)	
Manufacturing	
Soaking, fugitive tinting, conditioning, setting or twist	200

Table 8.1.10: Recommended Values of Illumination for Industrial Buildings and Processes (contd.)

Area or Activity	Illuminance (lux)
Textile Mills (Silk and Synthetics) (contd.)	
Winding, twisting, rewinding and coining, quilting and slashing	
Light thread	200
Dark thread	300
Warping (silk or cotton system) on creel, on running ends, on reel, on beam, on warp at beaming	300
Healding (drawing-in)	700
Weaving	300 - 500
Inspection	1000
Textile Mills (Woollen and Worsted)	
Scouring, carbonizing, testing, preparing, raising, brushing, pressing, back-washing, gilling, crabbing and blowing	150
Blending, carding, combing(white), tentering, drying and cropping	200
Spinning, roving, winding, warping, combing (coloured) and twisting	450
Healding (drawing-in)	700
Weaving	
Fine worsteds	700
Medium worsteds and fine woollens	450
Heavy woollens	300
Burling and mending	700
Perching	
Grey	700
Final	2000

Table 8.1.10: Recommended Values of Illumination for Industrial Buildings and Processes (contd.)

Area or Activity	Illuminance (lux)
Wood Working	
Rough sawing and bench work	150
Sizing, planing, rough sanding, medium machine and bench work glueing, veneering	200
Fine bench and machine work, fine sanding and finishing	300

Table 8.1.11: Recommended Values of Illumination for Storage Buildings

Area or Activity	Illuminance (lux)
Storage Rooms of Ware House	
Inactive	50
Rough bulky	50
Medium	100
Fine	250

Table 8.1.12: Recommended Values of Illumination for Outdoor Stadiums Colour TV broadcasting

Area or Activity	Illuminance (lux)
Football Stadium	1700
Cricket Stadium	2200

Table 8.1.13: Recommended Values of Illumination for Outdoor open yards

Area or Activity	Illuminance (lux)
Outdoor Car Parking Lot	100
Airport Apron	200
Container Yard	200
Jetty	250

Table 8.1.14: Recommended Values of Illumination for Roads

Area or Activity	Illuminance (lux)
Roads inside a Housing Area	50- 100
Roads in a Congested Town / City Area	50- 100
Wide Roads with dividers	100 - 120
Avenues	100 - 120

- (d) Semi-indirect fittings: Semi-indirect fittings shall be used when a comfortable brightness ratio between the ceiling and the luminaire is desirable but an efficiency of illumination, higher than that obtainable from indirect fittings is required.
- (e) Indirect fittings: Indirect fittings shall be used in situations where an environment of evenly distributed illumination is to be achieved.
- (f) Angle lighting: Lighting on vertical surfaces shall be done avoiding shadows using interior or exterior light fitting of appropriate type concentrated source light fitting depending upon the place and the color tone required. However, if creating shadows is necessary then appropriate type concentrated source light fitting should be chosen depending upon the place.

1.2.7 Illumination of Exit Signs and Means of Escape

1.2.7.1 Exit signs

- (a) All required exit signs shall be illuminated at night, or during dark periods within the area served.
- (b) Exit signs may be illuminated either by lamps external to the sign or by lamps contained within the sign. The source of illumination shall provide not less than 50 lux at the illuminated surface with a contrast of not less than 0.5. Approved self-luminous signs which provide evenly illuminated letters having a minimum luminance of 0.2 cd/m² may also be used.
- (c) Exit signs within an area where the normal lighting may be deliberately dimmed or extinguished, such as places of entertainment, shall be illuminated either by lamps contained within the sign or by approved self-luminous signs.

1.2.7.2 Means of Escape Lighting

- (a) The means of escape and exit access in buildings requiring more than one exit shall be equipped with artificial lighting. The lighting facilities so installed shall provide the required level of illumination continuously during the period when the use of the building requires the exits to be available.
- (b) The intensity of illumination at floor level by means of escape lighting shall not be less than 10 lux, except that the minimum required floor level illumination of aisles in assembly halls, theatres and cinema during projection of motion or still pictures by directed light shall not be less than 2 lux.
- (c) The illumination of exit signs and the lighting of the means of escape and exit access shall be powered by an alternate or emergency electrical system to ensure continued illumination for a duration of not less than 30 minutes after the failure of primary power supply.

1.2.8 Selection of Appropriate Type of Lamp

It is important to select appropriate types of lamps for each purpose. The lamps which are used for various purposes are:

(i) General Service Lamps (GLS)/Incandescent Lamps

General Service Lamps (GLS) are well known Incandescent Lamps. These are available in a number of watt ratings. However, most commonly used ratings are 40 W, 60 W, 100 W, 150 W and 200 W rated lamps are also used for special applications. These types of lamps produce heat and should be minimized while selecting for a particular design because other better choices are available nowadays. For kitchen, cooking areas of a hotel, serving counters of a food shop or hotel, porch these are often essential because of the color temperature. For living room, toilet, corridor, veranda, bed room these have been used for long but from energy saving point of view other lamps which perform better in terms of light output to watts ratio may be used. In general, the GLS type of lamp may be used for almost all interior and exterior applications but from energy saving point of view other lamps which perform better in terms of light output to watts ratio should be used as much as possible.

(ii) Fluorescent Lamps (FL):

These are available in 20 W and 40 W ratings. These lamps are strongly recommended for reading room, educational buildings, laboratories, office room, commercial space applications, factory illumination, illumination of areas around industrial plant and machineries, exterior lighting applications.

40 W FL should be used wherever possible because a 40 W FL is more energy efficient compared to a 20 W FL. These are long life lamps, have wide applications and are advantageous in many respects.

(iii) Compact Fluorescent Lamp(CFL) Energy Saving Lamps:

CFL Lamps are available in a number of watts ratings e.g., 4 W, 7 W, 11 W, 14 W and 24 W. CFLs have been finding wide application for almost all applications because of their high Light output to watts ratio and also because of the attractive light color. CFL lamps, therefore, should be widely used for energy saving purpose.

However, for reading areas, library areas, educational buildings, laboratories fluorescent lights give better service and thus should be selected for these purposes. It is worthwhile mentioning that Fluorescent lamps with high quality ballasts closely meet the energy saving purpose.

(iv) LED Lights:

Compact light fitting formed using a cluster of white LED is currently used to replace a conventional lamp. An LED operates at very small amount of voltage. These are good for lighting, energy efficient, have almost negligible heat dissipation. These are good for relaxed environment interior lighting. LED lights are becoming more and more popular because of much lower power consumption compared to other lamps.

(v) Halogen lamp:

Halogen lamps are used for spot lights, decorative lights in shops and commercial spaces, inside show cases, stage lighting, and projection lights. Due to high temperature rise and UV light output these should be avoided for interior lighting unless needed.

(vi) Mercury Vapour Lamp

These have been widely used for shops, streets, for high bay lighting, warehouse lighting and similar special lighting. Most likely, this type of lamp will be discontinued within next five to six years due some of it's ill effects. Metal halide lamp is coming up as a better alternative to mercury vapour lamp.

(vii) Metal Halide Lamp:

These are available in a number of watts ratings e.g., 150 W, 200 W, 250 W, 500 W, 1000 W, 2000 W. Good for exterior lighting, indoor and outdoor athletic facilities, for high bay lighting, warehouse lighting. These are required where massive flood lighting is required from high altitudes for coverage of large areas.

(viii) HP Sodium Lamp:

These are available in a number of watts ratings e.g., 40 W, 50 W, 70 W, 100 W, 150 W, 250 W, 400 W, 1000 W. Good for exterior lighting, Lighting for areas where higher concentration of vehicles and people exist e.g., Street lighting, building exterior lighting, security lighting.

(ix) Low Pressure Sodium Lamp:

For outdoor lighting such as street lights and security lighting where faithful color rendition is considered unimportant. This type of lamps may be used for street lights, observatory, parking lot and similar types of areas.

(x) Solar PV Cell Powered LED Lights:

These fittings require a solar panel, a storage battery system apart from the cluster of LEDs. For outdoor lighting such as street lights, security lighting, outdoor parking area, this type of light fitting may be used.







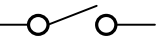
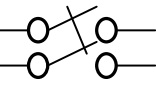
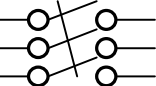
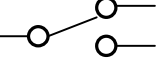


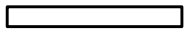
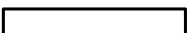
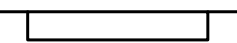

1.3 ELECTRICAL AND ELECTRONIC INSTALLATIONS IN BUILDINGS










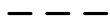
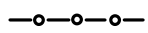
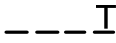
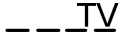

1.3.1 List of Symbols used for Electrical Drawings

A list of general graphical symbols used for electrical drawings is given in Table 8.1.15. These are given as guideline. In case of justified reasons a designer may modify certain symbol.

Table 8.1.15: Symbols used for Electrical Drawings

Serial No.	Description	Symbol
1	Main Distribution Board (MDB)	
2	Floor Distribution Board (FDB)	
3	Distribution Board (DB)	
4	Sub-distribution Board (SDB)	
5	Branch Distribution Board (BDB)	
6	Switch Board (SB)	
7	Telephone Outlet (PSTN)	
8	Telephone Outlet (PABX)	
9	Change over switch	
10	Energy meter	
11	Ammeter	
12	Voltmeter	
13	Power factor meter	
14	Circuit breaker	
15	Fuse	
16	Ceiling mounted Incandescent light fitting	
17	Wall mounted bracket light fitting	

Serial No.	Description	Symbol
18	Ceiling fan	
19	Exit light pendant	
20	Exit light-wall mounted	
21	2 pin socket Outlet (single phase)	
22	3 pin 13A switched socket Outlet (single phase)	
23	Weatherproof and waterproof socket outlet	
24	SPST Single – pole, one-way switch	
25	DPST Two - pole, one-way switch	
26	TPST Three - pole, one-way switch	
27	SPDT Two – way switch	
28	Push button switch	
29	Buzzer	
30	Single fluorescent lamp on ceiling	
31	Double fluorescent lamp on ceiling	
32	Double fluorescent lamp on wall	
33	Spot light	

Serial No.	Description	Symbol
34	Wall mounted bracket fan	
35	Exhaust fan	
36	Pull box	
37	TV socket outlet	
38	Fire Alarm bell	
39	Fire detector	
40	Smoke detector	
41	Speaker	
42	Microphone	
43	Conduit, concealed in ceiling or in wall	
44	Conduit, concealed in floor or through under ground	
45	Telephone conduit	
46	Television antenna conduit	
47	Earth Electrode	

1.3.2 Estimating the Load of a Building/Complex

Estimating the total load of a building has to be started with the listing of the connected loads in a building. The steps are to list the loads in each of the rooms, in each of the flats/offices of a floor, in each of the floors and the load of the total building. In this way an account of the total building area/the total complex has to be prepared. Loads of the Lift(s), water pump(s), bulk ventilating system in the basement and any other equipment installed in the building must also be added. For completing the load calculation, practical value of appropriate diversity factors will have to be applied at each stage.

Estimating the total load of a complex consisting of a number of buildings has to be started with the listing of the connected load of each of the buildings, they are lighting load, water pump and any other equipment installed in the complex. For completing the load calculation, practical value of appropriate diversity factors among the buildings will have to be applied.

1.3.2.1 Maximum demand and diversity

Two items need to be determined, which are: (i) Maximum demand and (ii) Diversity factor. These are needed in completing the load calculation and in the computation of current.

In determining the maximum demand of an installation or parts thereof, diversity shall be taken into account. Appendix A gives some information on the determination of the maximum demand of an installation and includes the current demand to be assumed for commonly used equipment together with guidance on the application of allowances for diversity.

1.3.2.2 Estimation of load in kW, in kVA and in Amperes

An estimation of loads is necessary initially for design purposes and later for keeping a track of the growth of load. Estimation of loads means estimation of watts or kilowatts in small scale. In bigger scale the kVA is assessed together with the power factor. A calculation of current is then to be performed for the selection of breakers/fuses and the current carrying cables.

1.3.2.3 Estimation of electrical load in Watts

Energy efficient and energy saving should be considered in estimating the electrical load, the watts rating of individual equipment/fittings connected to the system need to be listed and added. Typical watt ratings of some of the equipment/fittings are shown in Table 8.1.16 which may be used for estimation if the actual values are not known or specified.

Table 8.1.16: Estimated Load for Different Fittings/Fixtures

Type of Fitting/Fixture	Ratings in Watts	Type of Fitting/Fixture	Ratings in Watts
CFL	5-65	15 A Socket outlets	1500
LED and Solar Panel Powered LED Security /Street Lights	10-60	Microwave Oven (domestic)	1200-1500
Fluorescent lamp with accessories:		Washing machine (domestic)	350-500
Nominal length 600 mm	20	Television (medium size)	120-200

Type of Fitting/Fixture	Ratings in Watts	Type of Fitting/Fixture	Ratings in Watts
Nominal length 1200 mm	40	Computer (without printer)	200
Photo copiers	1200-1500	Computer with printer	700-800
Ceiling fans	100 (Max)	Window type A.C. machine (12000 BTU/hr)	1500
Electric	1500	Split type A.C. machine (12000 BTU/hr)	1300
Table fans	85 (Max)	Geyser (water heater, domestic)	1000-1200
Pedestal fans	120 (Max)	Toaster (domestic)	800-1000
Exhaust fans	100 (Max)	Electric calendar	700-1000
5A socket outlets	300		

1.3.2.4 Calculation of current

For the calculation of current (for the selection of cables and breakers) of the fluorescent lamps the ratings are to be multiplied by a factor of 1.65 to take care of the power factor and the starting current situation.

For the calculation of current (for the selection of cables and breakers) of the ceiling fans, table fans, pedestal fans, exhaust fans the ratings are to be multiplied by a factor of 1.65 to take care of the power factor and the starting current situation.

For the calculation of current (for the selection of cables and breakers) of the small inductive loads (up to 1.0 kW) the ratings are to be multiplied by a factor of 1.65 to take care of the power factor and the starting current situation. The factor shall be higher for higher rated motors.

1.3.2.5 Minimum load densities

While estimating the electrical load, the minimum load densities to be considered are those shown in Table 8.1.17.

1.3.3 Fittings, Fixtures and Accessories

Switch boards with back boxes and cover plates, ceiling roses, socket outlets with back boxes, plugs, light fittings, fans, pull boxes with cover plates have been put in this category, although there may be other items which may be included under electrical accessories related to electrical and electronic installations in buildings.

1.3.3.1 Switch boards

Tumbler switches have been used for surface wiring and piano switches have been used for concealed wiring. Now a day piano switches are also used with surface wiring. Piano switches are mounted on either a plastic back box or a metal back box. These piano switches are available in gangs. The other alternative is to have piano switches mounted on a Perspex or Ebonite sheet which is then mounted on a metal back box.

The Switches must conform to the relevant BS standard. The minimum ampere rating of switch shall not be below 5 A.

Switches may be Single Pole Single Throw (SPST) or Single Pole Double Throw (SPDT) depending on the operation. For some application Double Pole Single Throw (DPST) and Double Pole Double Throw (DPDT) are also available. Usually the DPST switches are made for 10 A, 15 A and 20 A rating.

The phase (Live) wire (Brown PVC insulated cable) connection to the point must go through the switch.

The metal / sheet steel back boxes of a switch board must have an earthing terminal to terminate the Earth Continuity Conductor (ECC) coming from a BDB or an SDB.

Table 8.1.17: Minimum Load Densities

Type of Occupancy	Unit Load (Watts/m ²)	
	Non A/C	A/C
Residence/ Dwelling : Single family	20	75
Residence/ Dwelling : Multi-family (other than hotels)	20	75
Hospitals	32	80
Hotels, including apartment house (excluding any provisions for electric cooking)	24	75
Office and commercial multi-storeyed buildings	28	75
Industrial building (excluding the loads for machines)	16	-

Type of Occupancy	Unit Load (Watts/m ²)	
	Non A/C	A/C
Departmental stores	28	75
Banks	20	75
Restaurants (excluding any provisions for electric cooking)	16	75
Barber shops and beauty parlours	32	75
Schools and colleges	12	70
Parking area in commercial buildings	4	-
Warehouses, large storage areas	2	-

1.3.3.2 Socket outlets and plugs

In general, all socket outlets must be switched (combined) and shuttered.

(a) General requirements of socket outlets

Socket outlets shall be 13 A switched shuttered 3 pin flat pin type. All socket outlets must be switched (combined) and shuttered and shall be for 3 pin Flat pin type (rectangular cross section) 13 A plugs fitted with tubular fuse.

The corresponding plugs must be fitted with fuse. The maximum fuse rating shall be 13A for 13A Sockets. The fuse rating may be smaller depending upon the current rating of the appliances used.

The phase wire (Brown cable) shall be connected to the L terminal of the socket outlet through the combined switch and the neutral wire (Blue cable) shall be directly connected to the N terminal of the socket. Earth Continuity Conductor (ECC) (Yellow + Green bi-colour cable) for such a socket outlet shall be connected to the Earth terminal of the socket.

The plug for each 13A socket outlet provided in a building for the use of domestic appliances shall be provided with its own individual fuse. The feed cables for such a circuit must have fuse or miniature circuit breaker (MCB) at the originating point in the Distribution Board or Sub-Distribution Board or Branch Distribution Board. For some high current applications, additional fuses/ circuit breakers adjacent to the sockets are recommended.

Each socket outlet shall also be controlled by a switch which shall normally be located immediately adjacent thereto or combined therewith.

The phase (Live) wire (Brown PVC insulated cable) connection to the socket outlet must be through the switch.

Copper size of the Earth Continuity Conductor (ECC) for such a socket outlet shall not be smaller in size than 1.5 mm² PVC insulated cable.

(b) 15 A/20 A rated socket outlets

(c) Round pin socket outlets of 15 A/20 A rating may be used for air conditioner outlets and water heater outlets under special circumstances, for air conditioner outlets (requiring 15 A or 20 A), 15 A/20 A rated socket outlets for round pin plugs may be used along with a circuit breaker or fuse protection in a box adjacent to the sockets..

Each 15 A/20 A socket outlet provided in a building for the use of domestic appliances such as air-conditioner, water cooler, etc. shall be provided with its own individual fuse. The feed cables for such a circuit must have fuse or miniature circuit breaker (MCB) at the originating point in the Distribution Board or Sub-Distribution Board or Branch Distribution Board. For some high current applications, additional fuses/circuit breakers adjacent to the sockets are recommended.

Each socket outlet shall also be controlled by a switch which shall normally be located immediately adjacent to the Socket or shall be combined with the Socket.

The corresponding plugs for 15 A should be fitted with fuse. The maximum fuse rating shall be 15 A for 15 A Sockets. For a 15 A rated socket outlet a 15 A rated fuse or a 15 A circuit breaker must be placed adjacent to the socket.

For a 20 A rated socket outlet a 20 A rated fuse or a 20 A circuit breaker must be placed adjacent to the socket.

Wiring for sockets shall be radial type of wiring. However, ring type wiring may be used by strictly following the rules given in IEE Wiring regulations BS 7671 and by using appropriate size of cable.

(d) Earth Continuity Conductor (ECC) for a socket

The ECC for a socket outlet shall not be smaller in size than 1.5 mm² PVC insulated annealed copper cable. The colour of the ECC cable insulation shall be Yellow + Green bi-colour.

(e) Mounting height of a three pin switched socket outlet

Three pin switched shuttered socket outlets shall be mounted on a wall at a height 250 mm above floor level. Switched shuttered socket outlets are essential for safety in particular for the safety of infants.

For certain applications like computers, printers, UPS, IPS such sockets may be mounted at a higher level for the ease of operation.

(f) Restriction on mounting socket outlets in wet places

No socket outlets shall be provided inside bath rooms/toilets or any other place where floor may remain wet.

(g) 5 A rated 2 pin socket outlets

5 A rated 2 pin socket outlets may be used along with the light and fan switch boards only. Such sockets shall not be used as socket outlets at the skirt level.

(h) Number of socket outlets in a room/in a building

The number of socket outlets in a building depends upon the specific requirements of occupants and the type of building. Adequate number of 13 A switched flat pin (rectangular cross section pin) shuttered socket outlets shall be provided and arranged around the building to cater to the actual requirements of the occupancy.

15 A round pin (rectangular cross section pin) socket outlets shall be provided for specially Air-conditioners and water heaters of such ratings only.

For residential buildings, the minimal guidelines given in Table 8.1.18 shall be used to determine the required number of 13 A switched flat pin (rectangular cross section pin) shuttered socket outlets, when actual requirements cannot be ascertained. All socket outlets shall conform to BDS 115.

Table 8.1.18: Minimum Number of 13 A flat pin Socket Outlets

Location	No. of Switch Socket Outlets
Bed room	2
Living room	3
Drawing room	3
Dining room	1
Toaster/Snack toaster	1
Kitchen	1
Bathroom	0
Verandah	1
Refrigerator	1
Air-conditioner	one for each room

(i) Restriction on installation of two socket outlets in room fed from two phases

Installation of two socket outlets in a room fed from two different phases should be avoided as far as possible. However, in unavoidable cases, the minimum distance between two such socket outlets in a room fed from two different phases must not be less than 2 m under any circumstances.

(j) Exterior/outdoor sockets

Socket outlets in exposed places where chances of dripping/falling rain water exist should not be placed. In case of necessity, weather proof/waterproof covered socket outlets may be mounted with appropriate precautions. In such a case the back box should preferably be of bakelite or Acrylic or plastic material.

(k) Exterior/outdoor switches

Switches in exposed places where chances of dripping/falling rain water exist should not be placed. In case of necessity, weather proof/waterproof covered switches may be mounted with appropriate precautions. In such a case the back box should preferably be of bakelite or Acrylic or plastic material.

1.3.3.3 Ceiling rose

A ceiling rose is needed for terminating the point wiring for a Light or a Fan in the ceiling.

(a) A ceiling rose shall not be installed in any circuit operating at a voltage normally exceeding 250 volts.

(b) Normally, a single pendant be suspended from only one ceiling rose using a flexible cord. A ceiling rose shall not be used for the attachment of more than one outgoing flexible cord unless it is specially designed for multiple pendants.

(c) A ceiling rose shall not contain a fuse terminal as an integral part of it.

(d) The ceiling rose shall conform to BS 67.

(e) Luminaire supporting couplers are designed specifically for the mechanical support as well as for the electrical connection of luminaires and shall not be used for the connection of any other equipment.

1.3.3.4 Light fitting

Switches shall be provided for the control of every light fitting. A switch may control an individual light point or a group of light points.

Where control at more than one position is necessary for a lighting fitting or a group of lighting fittings, as many two-way or intermediate switches may be provided as the required number of control positions.

In industrial premises light fittings shall be supported by suitable pipe/conduits, brackets fabricated from structural steel, steel chains or similar materials depending upon the type and weight of the fittings. Where a lighting fitting is to be supported by one or more flexible cords, the maximum weight to which the twin flexible cords may be subject are shown in Table 8.1.19.

Table 8.1.19: Maximum Permissible Weight to which Twin Flexible Cords may be Subject

Nominal Cross-sectional Area of Twin Flexible Cord (mm ²)	Number and Diameter (mm) of Wires	Maximum Permissible Weight (kg)
0.5	16/0.2	2
0.75	24/0.2	3
1.0	32/0.2	5
1.5	48/0.2	5.3
2.5	80/0.2	8.8
4	128/0.2	14

For a Light fitting with shade, no flammable shade shall form part of the light fitting and the shade shall be well protected against all risks of fire. Celluloid shade or lighting fitting shall not be used under any circumstances.

(a) Lighting point

At each fixed lighting point one of the following accessories shall be used

- (i) one ceiling rose conforming BS 67
- (ii) one luminaire supporting coupler conforming BS 6972 or BS 7001
- (iii) one batten lamp holder conforming BS 7895, BS EN 60238 or BS EN 61184
- (iv) one luminaire designed to be connected directly to the circuit wiring
- (v) one suitable socket-outlet
- (vi) one connection unit conforming BS 5733 or BS 1363-4.

A lighting installation shall be appropriately controlled e.g., by a switch or combination of switches to BS 3676 and/or BS 5518, or by a suitable automatic control system, which where necessary shall be suitable for discharge lighting circuits.

(b) Wires/cables used inside light fittings and any other fitting

Wires/cables used inside a light fitting or any other fittings are mostly flexible types. In some cases single core PVC insulated wiring cables mostly 1.5 mm² are used. In such cases the cables must be of high quality in terms of insulation and must have appropriate copper cross section. Such cables are usually terminated in a ceiling rose.

1.3.3.5 Fans

(a) Ceiling fan

Ceiling fans including their suspension shall conform to BDS 818.

With respect to the position of a lighting fitting, the positioning of a fan shall be such so that it does not throw any shadow on the working plane is not acceptable. The unit module area shall be so chosen that the required number of fans could be suitably located, to avoid creation of pockets receiving little or no air circulation.

In general, fans in large halls may be spaced at 3 to 3.5 m in both the directions in the horizontal plane. If building modules do not lend themselves to proper positioning of the required number of ceiling fans, other types of fans, such as air circulators or wall mounted bracket fans shall have to be installed for the areas uncovered by the ceiling fans. In such cases, necessary electrical outlets shall have to be provided for the purpose. Table 8.1.20 gives the recommended areas to be served by different sizes of ceiling fans where the height of fan blades is at 2.5 m above the finished floor level.

Table 8.1.20: Recommended Fan Sizes in Rooms

Room Area (m ²)	Fan Sweep
Up to 6	915 mm
Over 6 to 9	1220 mm
Over 9 to 12	1442 mm

Wiring for a ceiling fan outlet from the switch board up to the ceiling fan outlet shall be done through pre-laid 18 mm dia PVC conduits using 1.5 mm² PVC insulated 2 cables of Brown and Blue insulation. A high quality ceiling rose is to be installed at the ceiling fan point for the termination of the wiring and the connection of the two wires of the Fan.

A fan hook is required to be placed during casting of the roof. The fan hook is to be made using a 12 mm dia MS rod having at least 600 mm on both sides and shall be placed above the MS rod mesh of the roof slab.

(b) Wall mounted bracket fan

For Wall mounted bracket fans shall be mounted on the wall using appropriate rowel bolts. Wiring for a Wall mounted bracket fan outlet from the switch board up to the Wall mounted bracket fan outlet shall be done through pre-laid 18 mm dia PVC conduits using 1.5 mm² PVC insulated 2 cables of Brow and Blue insulation. A high quality ceiling rose is to be installed at the ceiling fan point for the termination of the wiring and the connection of the two wires of the Fan.

(c) Pedestal fans and table fans

These items are movable and no fixed connections are necessary. Sockets will be used to energize these fans.

(d) Installation/mounting of ventilating fans or exhaust fans

Exhaust fans are necessary for spaces, such as toilets, kitchens, canteens and godowns to provide the required air changes. Since the exhaust fans are located generally on the outer walls of a room, appropriate openings in such walls shall be provided right from the planning stage. The sizes and the rpm of the exhaust fans will vary according to the application and the volume for which a fan used. In some applications (such as some industries, big size gas generator room etc.) high rpm fans are essential. In all cases appropriate types of fan need to be chosen and appropriate arrangement need to be made so that rain water cannot get inside the rooms.

(e) Installation/mounting of ceiling fans

Ceiling Fans shall be suspended from Fan hooks that are to be placed in position during casting of the Roof.

(f) Fan hooks

Fan hooks may be concealed (hidden) or may be exposed type. Fan hooks shall be made using MS rods of 12 mm diameter. The diameter of this rod shall not be below 10 mm under any circumstances.

(g) Ceiling roses for fan points

Appropriate type of ceiling roses must be provided at the fan points for the termination of the Fan point wiring cables. Connection to the Ceiling Fans will go from the ceiling roses.

(h) Cutout box/circuit breaker box

If the BDB or the SDB from which a 3-pin switched shuttered socket receives power is at a significant distance away and the load connected to the socket needs special care an additional cutout box or a circuit breaker box may be placed adjacent to the socket. Such a cutout Box or a Circuit Breaker box shall be placed inside a 18 SWG Sheet Steel (coated with two coats of synthetic enamel paint) of appropriate size with appropriate Perspex cover plate. Such a box may be surface fitted or may be concealed fitted. The box shall have a brass terminal for the termination of the ECC.

1.3.4 Distribution Wiring in a Building

1.3.4.1 General

Loads are separated into known and unknown loads.

General illumination is a known load, whether derived from detailed lighting layout, or developed from watts per square meter calculation. Similarly fans are also known loads. Besides these two types, there may be some other known loads.

Number, rating and layout of outlets for general illumination, fans and other known loads should accurately be distributed among a number of branch circuits. These branch circuits should then be carefully loaded with due regard to voltage drop, operating voltage and possible increase in lighting levels in future. On the other hand the sockets are unknown loads. Socket loads will be determined from projections based on the utility of the building and type of applications.

Every installation shall be divided into small circuits (following the rules given in this document) to avoid danger in case of a fault, and to facilitate safe operation, inspection, maintenance and testing. For the establishment of the circuits appropriate type of wiring is needed and appropriate terminations/connections/junctions of these circuits are needed. At the same time appropriate types of protection against faults must be given at different levels. These are to be achieved through installation of appropriate distribution wiring in the building.

1.3.4.2 Distribution board

A Distribution Board is the junction point of the incoming line and the outgoing lines for the distribution of Electricity throughout the building. The incoming as well as the outgoing lines must have Circuit Breaker protection or Fuse protection. The junctions and terminations of the incoming and outgoing cables are made through copper bars containing bolts and nuts for cable lugs known as bus-bars. A Distribution board may be named as MDB or FDB or DB or SDB or BDB.

- (a) MDB stands for Main Distribution Board. This is the distribution box where the main incoming cable enters and terminates from the main service feed connection of a large building. The FDBs get feed from MDB.
- (b) FDB stands for Floor Distribution Board located in each of the floors of a multistoried building. The DBs get feed from FDB. Usually, more than one FDB are needed.
- (c) DB is the abbreviation for Distribution Board. This may be the box where the main incoming cable enters and terminates from the main service feed connection. The SDBs get feed from a DB.

- (d) SDB is used to represent Sub- Distribution Board. This board is located in the same floor of a building and connected to the DB. Usually more than one SDB are needed. The BDBs get feed from SDB.
- (e) BDB stands for Branch-Distribution Board located in the same floor of a building and connected to the SDB. Usually more than one BDB are needed.
- (f) EDB, EFDF, ESDB, EBDB Sections of DB, FDB, SDB, BDB receiving feed from the Emergency Bus-bar which in turn is getting feed from standby generator through changeover switch. These may be separate DBs placed by the corresponding normal supply DBs.

Each of these distribution boards must have busbars for Line, neutral and earthing for a single phase box. A 3-phase distribution board must have busbars for Line 1, Line 2, and Line 3, neutral and earthing.

These boxes shall be made with sheet steel of not less than 18 SWG thicknesses and must be appropriately paint finished to match the wall paint.

1.3.4.3 Circuit wiring

(a) Separate branch circuits for separate control

Separate branch circuits shall be provided for different parts of a building area which need to be separately controlled. A branch circuit should be independently working and should not be affected due to the failure of another branch circuit.

The number of final circuits (also termed as sub-circuits or circuits) required and the points supplied by any final circuits shall comply with

- (i) the requirement of over-current protection,
- (ii) the requirement for isolation and switching, and
- (iii) the selection of cables and conductors.

All final circuits shall be wired using loop wiring system; no joint box shall be used.

Sufficient number of 18 SWG sheet steel made (painted with two coats of grey synthetic enamel paint) pull boxes, with ebonite/perspex sheet cover plate, must be given on the walls near the ceiling. If brick walls are not available, pull boxes must be given in the ceilings.

(b) For domestic and office buildings

5A Light/Fan Circuits must be used for all Domestic and Residential buildings. 5A Light/Fan Circuits are also to be used for Office and commercial Buildings. The corresponding circuit wire in the BDB/ SDB/ DB then shall be not less than 1.5 mm².

(c) For office and commercial buildings having large open floor areas

Under unavoidable circumstances, in case of difficulties in forming 5 A light/fan circuits for office and commercial buildings having large open floor areas, 10 A light/fan circuits may be used. The corresponding circuit wire in the BDB/SDB/DB then shall be not less than 2.5 mm². However, use of 5 A light/fan circuits is still emphasized.

(d) For industrial/factory buildings having large open floor areas

For industrial/factory buildings having large open floor areas, 10 A light/fan circuits may be used.

(e) For industrial/factory buildings/warehouses having too large open floor areas

For industrial/factory buildings/warehouses having large open floor areas, efforts should be given to use circuits not exceeding 10 A. The corresponding circuit wire in the BDB/SDB/DB then shall be not less than 2.5 mm².

For Industrial/Factory Buildings having very large open floor areas, 15 A light/fan circuits may be used as exceptional cases only. The corresponding circuit breaker in the BDB/SDB/DB then shall be not less than 4 mm².

Increase in the sizes of the above mentioned cables may be required if the distance is too long. Voltage drop calculation will give the guidance in that case.

(f) Separate branch circuits from Miniature Circuit Breaker (MCB)

Separate branch circuits shall be provided from miniature circuit breaker (MCB) of a BDBD/SDB or fuse of the fuse distribution boards (FDB) for light/fan.

Separate branch circuits shall be provided from miniature circuit breaker (MCB) of a BDBD/SDB or fuse of the Fuse distribution boards (FDB) for automatic and fixed appliances with a load of 500 watt or more and socket outlets. Each automatic or fixed appliance shall be served by a protected socket circuit.

(g) Less than 50% loading of circuits with more than one outlet

Circuits with more than one outlet shall not be loaded in excess of 50% of their current carrying capacity.

(h) Branch circuits must have spare capacity to permit at least 20% increase in load

Each branch circuit running between a DB and a SDB, between a SDB and a BDB must have spare capacity to permit at least 20% increase in load before reaching the level of maximum continuous load current permitted for that circuit

- (i) One spare circuit must be allowed in the distribution board for each five circuits in use.

At least one spare circuit must be allowed in the distribution board for each five circuits in use. Additional space for a circuit breaker along with the provision for connecting a pair of outgoing cables shall be kept.

- (j) Each final circuit shall be connected to a separate way in a distribution board

Where an installation comprises more than one final circuit, each final circuit shall be connected to a separate way in a distribution board. The wiring of each final circuit shall be electrically separate from that of every other final circuit, so as to prevent unwanted energization of a final circuit.

- (k) Size of cables in a branch circuit shall be at least one size larger than that needed for the computed load current

Size of cables to be used in a branch circuit shall be at least one size larger than that computed from the loading if the distance from the over-current protective device to the first outlet is over 15 m.

- (l) 4 mm² (7/0.036) and 6 mm² (7/0.044) wiring cable for a 15 A socket outlet branch circuit

The minimum size of wiring cable used for a 15 A socket outlet branch circuit shall be 4 mm² (7/0.036). When the distance from the over-current protective device to the first socket outlet on a receptacle circuit is over 30 m the minimum size of wire used for a 15 A branch circuit shall be 6 mm² (7/0.044).

- (m) Length of a lighting circuit

The length of a lighting circuit shall be limited to a maximum of 30 m, unless the load on the circuit is so small that voltage drop between the over-current protective device and any outlet is below 1 percent.

- (n) Use of common neutral for more than one circuit is prohibited

Each circuit must have its own neutral cable. Use of common neutral cable for more than one circuit is not permitted.

- (o) Following the appropriate new colour codes of cables

During wiring, correct colour codes of the insulation of the cables must be used.

Previously, for a single phase circuit red colour insulation was used for the live wire and the black colour insulation for the neutral and green + yellow bi-colour insulation was used for the ECC. Previously, for a three phase circuit red colour was used for the live (L1), Yellow colour for the live (L2), Blue colour for the live (L3) cable and the black

colour for the neutral and green + yellow bi-colour for the ECC. This colour code of cables shall now be replaced by the current IEC cable colour code standards, Table 8.1.21 and Figure 8.1.1. The current IEC colour code is recommended to be followed in Bangladesh.

Table 8.1.21: New introduced Colour Codes of Cables Following IEC Standards

Item	Pre-1977 IEE	Pre-2004 IEE	Current IEC
Protective earth (PE)	Green	Green/yellow bi-colour	Green/yellow bi-colour
Neutral (N)	Black	Black	Blue
Single phase: Line (L) Three-phase: L1	Red	Red	Brown
Three-phase: L2	Yellow	Yellow	Black
Three-phase: L3	Blue	Blue	Grey

Existing

Harmonised

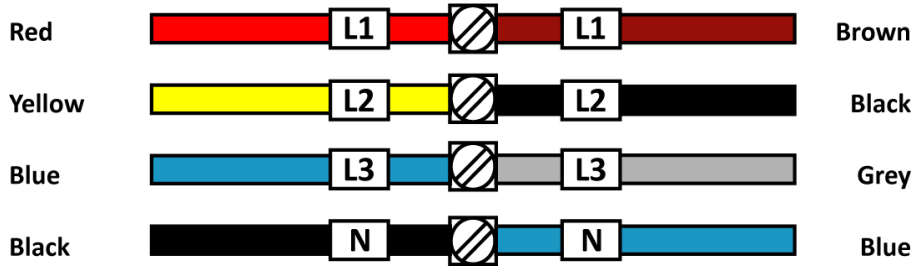


Figure 8.1.1 Existing and harmonised colour code by IEC recommended for use in Bangladesh.

The above mentioned colour coding must be indicated in the design drawing. This should also be mentioned in the specification.

(p) Balancing of circuits in three phase SDBs, DBs, FDBs, and MDBs.

In a 3 phase distribution system special care must be taken during wiring to obtain balancing of loads among the three phases.

In a 3 phase SDB, DB, FDB, MDB connections of the circuits to the bus-bars must be made in such a way so that the load current remains balanced among the three lines during low load as well as full load. After completing the installation balancing should be checked by clamp meter current measurement of each phase.

The above mentioned current balancing must be indicated in the SDB (if 3 phase), DB, FDB, and MDB circuit diagram of design drawing. This should also be mentioned in the specification.

1.3.5 Electrical Layout and Installation Drawings

An electrical layout drawing shall be prepared after proper locations of all outlets for lamps, fans, fixed and transportable appliances, motors etc. have been selected. This is the beginning of the electrical distribution design work. This job must be done with due importance prior to starting the construction and installation work. Strong emphasis is given on this work in this document.

1.3.5.1 Locating positions of the points on the plan of the building

At the beginning, the Light points, Fan points, Socket points, Switch Boards, BDBs, SDBs, FDBs. DBs and MDBs shall be located on each plan based on convention, suitability, application and safety view point.

Conduit layout and cable layout shall then be shown on the drawing.

1.3.5.2 Light and fan circuits must not be mixed with the socket circuits

In designing the wiring layout, power (socket) and heating (socket) sub-circuits shall be kept separate and distinct from light and fan sub-circuits.

All wiring shall be done on the distribution system with main and branch distribution boards placed at convenient positions considering both physical aspects and electrical load centres. All types of wiring whether concealed or surface, shall be as near the ceiling as possible. In all types of wiring due consideration shall be given to neatness and good appearance.

1.3.5.3 Balancing of circuits in three phase distribution boxes is a must

Balancing of circuits in three phase installations shall be arranged in the drawing and also must be done during physical connection.

1.3.5.4 Single phase socket outlets receiving connection from two different phases

Single phase socket outlets receiving connection from two different phases located in the same room is to be avoided. However, if it is essential to have such socket connection these must be located 2 m or more apart.

1.3.5.5 Electrical Layout drawings for industrial premises

Electrical layout drawings for industrial premises shall indicate the relevant civil structure/barrier/duct and mechanical equipment/duct.

1.3.5.6 Preparation of detailed circuit diagram

Circuit diagrams of each of the Light and Fan circuits must first be prepared based on the selection whether it is 5A or 10A circuit. The cable size of each of the circuit's size of the ECC must be shown in the drawing. The circuit diagrams of the BDBs, SDBs, DBs, FDBs, and MDBs etc. are then to be prepared and presented in the form of single line drawings indicating the cable sizes of each interconnection and the sizes of the ECCs. The distribution of BDBs, SDBs, DBs, FDBs, MDBs etc. are to be shown in a distribution drawing indicating the cable sizes of each interconnection and the sizes of the ECCs.

1.3.5.7 Preparation of electrical distribution and wiring design drawing by an experienced Engineer

Electrical Distribution and Wiring Design drawing of building must be prepared by an eligible Engineer as mentioned in Table 2.3.4 Chapter 3 Part 2.

1.3.6 Electrical Wiring in the Interior of Buildings

1.3.6.1 Surface wiring or exposed wiring

Wiring run over the surface of walls and ceilings, whether contained in conduits or not, is termed as surface wiring or exposed wiring.

Single core PVC insulated copper through PVC channels or through PVC conduits or through GI pipes of approved quality may be used for surface wiring.

Surface wiring using twin core flat PVC insulated copper on wooden battens used to be used long back. This is almost discontinued and discouraged now a day.

PVC conduits or GI pipes, when used for surface wiring, shall be clamped with saddles at a spacing not exceeding 600 mm, to the wall or ceiling using plastic rowel plugs with countersunk galvanized screws.

(a) Surface wiring using wood battens

The wood batten used in this method shall be of good quality wood with a minimum thickness of 12 mm. They shall be installed exposed and run straight on the ceiling or wall surfaces. Battens on walls shall be run either horizontally or vertically, and never at an angle. Battens on ceilings shall run parallel to the edges in either orthogonal direction, and not at an angle, they shall be fixed to the wall or ceiling by rowel plugs and countersunk galvanized screws. Cables shall be fixed to the battens by using galvanized steel clips or brass link clips or PVC clips of required size at a spacing not exceeding 100 mm.

(b) Surface wiring using PVC conduits

PVC conduits or GI pipes, when used for surface wiring, shall be clamped with saddles at a spacing not exceeding 600 mm, to the wall or ceiling using plastic rowel plugs with countersunk galvanized screws.

The conduits placed concealed inside roof or in wall must have 20 SWG GI pull wires placed during laying of the pipes for pulling the cables later.

(c) Surface wiring using PVC channels

Surface wiring may be done using single core PVC insulated cables placed inside surface fixed PVC channels of appropriate size. Fixing of channels must be done using screws in rowel plugs inserted into drilled holes on the walls/ceilings. The channels must be placed in a straight line with adequate number of screws so that no sag is observed. Cables must not be stressed in the bends. Adequate space must exist inside the channel to put the cables in position without difficulty.

Surface wiring using flexible chords, clips and nails shall not be used in general.

(d) Surface wiring using Round core flexible cable with plastic clips and nails

Surface wiring using exposed Round core flexible cable with plastic clips and long nails have been used for extending a point wiring, for extending a socket wiring due to shift, for add a circuit wiring.

This is not recommended for regular wiring. Instead of using this method, one should go for the recommended surface wiring using single core PVC cables with PVC channels or single core PVC cables with PVC conduits as mentioned above in this document.

For a length of not exceeding 1 m this may be used only for shifting an existing Light/Fan point or for shifting an existing socket point only under unavoidable circumstances.

1.3.6.2 Concealed wiring

The wires in this type of wiring shall be placed inside GI conduits or PVC conduits that are buried in roofs and in brick/concrete walls. The conduits in the walls shall be run horizontally or vertically, and not at an angle.

Conduits in concrete slabs shall be placed at the centre of thickness and supported during casting by mortar blocks or 'chairs' made of steel bars or any other approved means. All conduits shall be continuous throughout their lengths.

Appropriate planning should be made in which there shall be adequate spare capacity in the conduits placed in roof slabs so that unforeseen situation during execution of the installation can be taken care of. Conduits will run through the roof and then bend downward for going up to the outlets, DBs, switch boards, sockets.

In a column structure building having no permanent walls, switch boards and socket boards, pull boxes shall be placed in columns and must be done during the casting of columns.

Concealed wiring through floors and upward mounting of PVC/GI pipes from the floor is strongly discouraged because of the occurrence of condensation and accumulation of water from condensation eventually leading to damaging of the simple PVC insulated cable insulation. This method should not be followed as a general practice.

Underground cables for electrical distribution in the premises/garden/compound of the building shall be encased in GI or PVC pipes and laid in earth trenches of sufficient depth. Armoured cables need not be encased in conduits except for crossings under road, footpath, walkway or floors.

The conduits placed concealed inside roof or in wall must have 20 SWG GI pull wires placed during laying of the pipes for pulling the cables later.

1.3.6.3 Wiring inside suspended ceilings (false ceilings)

Wiring inside suspended ceilings (false ceilings) shall be surface wiring through conduits or through PVC channels mentioned under the heading of surface wiring methods.

Cables shall not be placed loosely and haphazardly on the suspended ceilings. Placing naked cables inside the suspended ceiling is not permitted.

Cable joints with PVC tape wrapping is not allowed for connection of a fitting from the ceiling rose or from a junction box inside the gap space.

1.3.6.4 Wiring through cable tray

Wiring for connections to some machines may be carried through a cable tray suspended from the ceiling. This is very rare for a domestic building. However in a commercial / office or industrial building this technique may be needed. In special circumstances Cables may be pulled through pre laid GI/ PVC pipes under the floor where there will be no chances of water accumulation in the floor or condensation.

1.3.6.5 Mounting height of light and fan switch boards

Light and fan switch boards shall be placed 1220 mm above floor level in the residential buildings (i.e, the clearance between the floor and the bottom of the switch board shall be 1220 mm).

This above mentioned height shall be 1300 mm above floor level in the office buildings, commercial buildings and industrial buildings. However, the minimum height shall not be below 1220 mm.

1.3.6.6 Restriction on the use of plastic/PVC insulated flexible chords/cables

Plastic/PVC insulated flexible chords/cables shall not be used for wiring of light/fan points or for wiring of sockets, or for wiring of any sub circuits.

1.3.6.7 Cable joints and cable joint boxes in concealed and surface wiring

Both the Brown (L) and Blue (N) cables of a final circuit shall run from a BDB/SDB up to the switch board without a joint. Similarly, both the Brown (L) and Blue (N) cables of a point shall run from the point up to the switch board. Cable joints are to be made in the switch board back box. Where the above methods are not implementable, joints shall be made using approved cable joint methods.

1.3.7 Methods of Point Wiring and Circuit Wiring

1.3.7.1 Methods of Point Wiring

Wiring between a light/fan point and its corresponding switch board is termed as Point Wiring. The load of such a point is not in excess of 100 watts in general, and in special cases this may be up to 200 watts. Wiring for a light/fan point shall be made using one of the following two methods: (i) Surface wiring or (ii) Concealed wiring. For wiring of a point one brown and one blue PVC insulated copper cable shall run between a point and its switch board. Cable joints inside conduits or within channels are forbidden. The current carrying capacity for such a circuit shall not be more than 5 A for a residential or a commercial (business/mercantile) building. The minimum size of a cable for such wiring shall be 1.5 mm².

Common neutral shall not be used under any circumstances.

1.3.7.2 Methods of Circuit Wiring

Wiring between a switch board and a BDB/SDB/DB will be called Circuit Wiring. Circuit wiring shall be done with a live cable a neutral cable and an ECC cable for a single phase circuit. Sometimes this circuit is also referred to as sub-circuit.

An ECC must be provided with each circuit. The ECC at the switch board end shall be terminated in the earth terminal of the metal part of the switch board using a brass screw/bolt and a nut. The BDB/SDB/DB end of the ECC shall be terminated in the earthing busbar of the BDB/SDB/DB.

The ECC in this case shall be PVC insulated copper cable of appropriate size but with yellow + green bi-colour insulation.

For each circuit, the live cable must be drawn using brown colour insulated PVC cable and the neutral cable shall be drawn using blue colour insulated PVC cable.

Common neutral shall not be used under any circumstances.

The minimum sizes of cable for various uses shall be as follows:

- (a) For a 5 A circuit protected by a 5 A circuit breaker or fuse shall not be below 1.5 mm²
- (b) For a 10 A circuit protected by a 10 A circuit breaker or fuse shall not be below 2.5 mm².
- (c) For a 15 A circuit protected by a 15 A circuit breaker or fuse shall not be below 4 mm².
- (d) For a 20 A circuit protected by a 20 A circuit breaker or fuse shall not be below 6 mm².

The above mentioned sizes must be increased for long cables as mentioned elsewhere in this document.

In general, the minimum size of cable for a particular circuit shall depend on the rating of the fuse or circuit breaker used for the protection of that circuit. A voltage drop check is to be made for each length of the circuit to ensure that the voltage drop at the farthest end of the load from the main distribution point does not exceed 2.5 percent.

Sockets shall get direct connection from the BDB/SDB through breaker/fuse protection. Depending on the assessed requirements sockets may be grouped/looped at the socket end. Such grouping shall not exceed 3 numbers of sockets in one circuit.

1.3.8 Feeder Wiring between SDB and BDB, DB and SDB, FDB to DB, MDB to FDB etc.

Wiring between a BDB and an SDB, an SDB and a DB, a DB and an FDB, an FDB and an MDB needs special attention and the rules are similar to Circuit Wiring. ECC must be present for each of the feed connections. The ECC in this case also shall be PVC insulated copper cable of appropriate size but with Green + Yellow bi-colour insulation.

At both ends the ECC must be terminated at the earthing busbar.

Appropriate cable lugs/cable sockets must be used for terminating the L1, L2, L3, N and E connections on the busbars of both the boards. The sizes of the cables must be chosen to match with the rating of the circuit breaker/fuse ratings as mentioned above.

Circuit breakers/fuses must be provided at the outgoing and incoming sides of each of the busbars of each BDB/SDB/DB/FDB boxes.

1.3.9 Conduits, Channels, Cables, Conductors and related Accessories

Conduits, Cables, Conductors and Accessories are important parts of an electrical distribution installation.

1.3.9.1 Conduits and conduit fittings

Cables of an electrical distribution installation are drawn through electrical conduits. For the installation of conduits various types of fittings are needed. For the two types of commonly used conduits, PVC and Metal, fittings should be as under.

(a) PVC conduits

- (i) PVC conduits and conduit fittings shall be of heavy wall water grade type. All bends shall be large radius bends formed by heat or by mechanical bending machine. The cross-section of the conduit shall remain circular at the bend and the internal diameter shall not be reduced due to bending. PVC pipe fittings shall be sealed with PVC solvent cement or adhesive for PVC of approved quality.
- (ii) Conduits installed in floors, if installed, shall have a slope of at least 1:1000 towards floor mounted pull box or cable duct.
- (iii) Conduits placed concealed inside roof or in wall must have 20 SWG GI pull wires placed during laying of the pipes for pulling the cables later.
- (iv) Water grade PVC conduits must be used for both concealed and surface wiring. Water grade PVC conduits of different diameters shall be used as per necessity.
- (v) Appropriate high grade bends and circular boxes must be used with the PVC pipes.
- (vi) 18SWG metal sheet made and synthetic enamel paint coated quality boxes of matching sizes shall be used as pull boxes and junction boxes. Appropriate pull-box covers of ebonite or perspex sheet shall be fitted with GI machine screw and washer.
- (vii) The PVC conduits placed concealed inside roof or in wall must have 20 SWG GI pull wires placed during laying of the pipes for pulling the cables later.

(b) PVC channels

PVC channels should be used only for extension work in an already installed building. A design drawing should not show use of such wiring except inside a false ceiling. Even inside the false ceiling this item should be used for lengths. For long distances PVC conduits should be used. High quality PVC channels of sufficient thickness should be used and fixed in a neat manner. For large number of cables and for thick cables PVC channels should not be used.

(c) PVC flexible pipes/conduits

PVC flexible conduits shall be used with surface wiring only and only in places where PVC bends cannot be used. Except special circumstances flexible PVC conduits shall not be used.

(d) Metal/steel conduits

Galvanized Iron (GI) conduits shall be made using at least 16 SWG sheet. The conduits shall have seamless joint along the length and must be suitable for making bends. No projections are allowed inside the conduits. Metal conduits must be threaded for end to end joints using sockets. In case of necessity, threads will be cut at the end of short pieces. Sharp edges at the ends must be properly treated so that cable injury does not take place during cable pulling.

(e) Pull boxes

- (i) Pull boxes/Joint boxes must be placed closed to the ceiling where conduits from the ceiling are going downward toward a switch box or are going toward a socket box or are going toward a BDB/ SDB/ DB / FDB.
- (ii) Pull boxes are extremely essential for pulling the cables without injuring the cables and thus should not be avoided under any circumstances. These are also essential for future maintenance and extension work.
- (iii) Pull boxes/Joint boxes must be placed in the ceiling of office/factory building where conduits are running over a long distance between two walls (terminal points) and where fixed walls are not available and also where heavy beams are used. In case of big cross section beams pull boxes/joint boxes shall be placed closed to the beams.
- (iv) Pull boxes/Joint boxes must be made with 18 SWG GI sheet or with 18 SWG MS sheet but coated with two coats of Grey Synthetic Enamel paint.
- (v) Covers of pull boxes should be ebonite or perspex sheet of not less than 1/8 inch thickness.

(f) Metal Boxes for Switch Boards

Metal Boxes for Switch Boards must be made with 18 SWG GI sheet or with 18 SWG MS sheet but coated with two coats of Grey Synthetic Enamel paint. A Switch Board Metal Box must have a small Copper / Brass earthing busbar for terminating the ECCs.

(g) Switches for operating light and fan points

Switches for operating Light and Fan points must be of 5A rating. These switches are usually SPST type. However, for special applications like stairs and some other places these may be SPDT type.

Switches for operating Light and Fan points may be of Gang type or may be isolated type. The isolated types are to be mounted on an ebonite top plate which is again fitted on the above mentioned Metal boxes for Switch Boards.

(h) Mounting regulators of ceiling fans

Metal Boxes for Mounting Inductor Regulators of Ceiling Fans must be made with 18 SWG GI sheet or with 18 SWG MS sheet but coated with two coats of Grey Synthetic Enamel paint. Metal Boxes for mounting regulators of ceiling fans must have a small copper/brass earthing busbar for terminating the ECCs.

However, such regulators may be placed inside the 18 SWG GI sheet or MS sheet made Metal Boxes for Switch Boards. In such a case arrangements must be made so that the PVC insulated point and circuit wiring cables and their joints inside the switch board do not touch a regulator. This may be done by appropriately dressing the cables and fastening the cables by using polymer cable fasteners.

1.3.9.2 Cables and conductors

For application in building wiring, PVC insulated stranded cables shall be used for Live and Neutral Wires for single phase and 3-lines (L1, L2, L3) and one neutral for 3-phase. For ECC also PVC insulated stranded cables shall be used. As a result, use of bare conductors is non-existent.

(a) Cables

Conductors of a PVC insulated cable, thin or thick, shall be copper. Cable containing Aluminum conductors may be used for thick cable of size more than 35 mm² but copper is always preferred.

Cables for power and lighting circuits shall be of adequate size to carry the designed circuit load without exceeding the permissible thermal limits for the insulation. The voltage drop shall also be within the specified limit of 2.5 percent from a distribution point up to their farthest end of the load point. Recommended sizes (in mm²) of copper conductors are as follows:

1, 1.5, 2.5, 4, 6, 10, 16, 25, 35, 50, 70, 95, 120, 150, 185, 240, 300, 400, 500,
630, 800, 1000

For final circuit/sub-circuit and for Light/fan point wiring the cable nominal cross-section of the cable shall not be less than 1.5 mm² for copper conductors.

Standard copper conductor sizes of cables which should be used for electrical installations/distribution in buildings are given below. Conductors of sizes other than the sizes listed below are not recommended.

(b) Phase and neutral cables shall be of the same size

In the wiring of the sub-circuit/circuit and all other circuits inside a building the Phase cable and the neutral cable shall be of the same size.

(c) Flexible cables/flexible cords

The minimum cross-sectional area of conductors of flexible cables/flexible cords shall be 0.5 mm² for copper conductors. Flexible cable or cords shall not be used as fixed wiring unless contained in an enclosure affording mechanical protection.

Flexible cables/flexible cords may be used for connections to portable equipment. For the purpose of this regulation an electric cooker of rated input exceeding 3 kW is not considered to be portable. The flexible cord shall be of sufficient length so as to avoid undue risk of damage to the outlet, cord or equipment and of being a hazard to personnel.

(d) Treatment of cable ends/cable terminations

All stranded conductors must be provided with cable sockets/cable lugs of appropriate size fitted using appropriate hand press tool or hand crimp tool or hydraulic press tool depending on the size of the cable. This is necessary for termination of the cable ends on bus-bars.

(e) Jointing of cables in wiring

Cable joints for the PVC insulated cables used in circuit wiring (thin cables) are to be made through porcelain/PVC connectors with PIB tape wound around the connector before placing the cable inside the box joint/pull box.

1.3.10 Conduits through the Building Expansion Joints

Conduits shall not normally be allowed to cross expansion joints in a building. Where such crossing is found to be unavoidable, special care must be taken to ensure that the conduit runs and wiring are not in any way put to strain or are not damaged due to expansion/contraction of the building structure. In unavoidable situations, PVC conduit through an oversize flexible PVC conduit may be used with pull boxes on both sides of expansion joints.

1.3.11 Types of Electrical Wiring for Exterior Lighting and other exterior purposes

1.3.11.1 Electrical wiring for garden lighting

For garden lighting PVC insulated PVC sheathed underground cables shall be used. For protection purpose these may be drawn through PVC pipe of appropriate dimension so that adequate clearance remains for the ease of pulling. In general, no junction of cables shall be provided in underground level. However, in case of necessity, metal sleeve cable ferrule joints using Crimp Tool or hydraulic press and heat shrink insulated sleeve shall be used on top.

1.3.11.2 Electrical wiring for street lighting

For street lighting PVC insulated PVC sheathed underground cables shall be used. For protection purpose these may be drawn through PVC pipe of appropriate dimension so that adequate clearance remains for the ease of pulling. In general, no junction of cables shall be provided in underground level. However, in case of necessity, metal sleeve cable ferrule joints using Crimp Tool or hydraulic press and heat shrink insulated sleeve shall be used on top. Joining the cables at the bottom of a street pole must be done inside a metal joint box located sufficiently above the street level so that water cannot reach the box even during the worst rain/flood situation.

1.3.11.3 Electrical wiring for boundary light

For boundary lighting PVC insulated PVC sheathed underground cables shall be used. For protection purpose these may be drawn through PVC pipe of appropriate dimension so that adequate clearance remains for the ease of pulling. In general, no junction of cables shall be provided in underground level. However, in case of necessity, metal sleeve or cable ferrule joints using Crimp Tool or hydraulic press and heat shrink insulated sleeve shall be used on top. However, for the portion of the cable running concealed through a wall, PVC insulated cables through PVC conduits may be used.

1.3.12 Branch Distribution Boards, Sub-distribution Boards, Distribution Boards, FDBs and MDBs

1.3.12.1 Enclosure/box

Enclosures for sub-distribution boards located inside the building shall be dust-proof and vermin-proof using sheet steel fabrication of a minimum thickness of 20 SWG. The boards shall be safe in operation and safe against spread of fire due to short circuit.

1.3.12.2 Size of the enclosure of a BDB/SDB/DB/FDB/MDB

Table 8.1.22 provides a guidance of sizes of enclosures for SDB containing miniature circuit breakers or fuses. However, the size will depend on the number and size of the circuit breakers or the fuses the number of outgoing cables and their sizes, the size of the busbars and the type of insulators used for the busbars.

Table 8.1.22: Recommended Enclosure Sizes for MCB's and Fuses

Dimensions (mm)			No. of MCB's or Fuses
Height	Width	Depth	
350	390	120	up to 12
480	390	120	up to 24
610	390	120	up to 36
740	390	120	up to 48

1.3.12.3 Location

A Sub-distribution board (SDB) shall be located as close as possible to the electrical load centre for that SDB. This is also applicable for determining the locations of FDBs, DB and BDBs. These boards shall never be located on water soaked or damp walls.

1.3.12.4 Wiring of sub-distribution boards

- (a) In wiring a sub-distribution board, total load of the consuming devices shall be distributed, as far as possible, evenly between the numbers of ways of the board, leaving the spare way(s) for future extension.
- (b) All connections between pieces of apparatus or between apparatus and terminals on a board shall be neatly arranged in a definite sequence, following the arrangements of the apparatus mounted thereon, avoiding unnecessary crossings.
- (c) Cables shall be connected to terminals only by soldered or welded lugs, unless the terminals are of such form that it is possible to securely clamp them without cutting away the cable strands.

1.3.13 Electrical Services Shafts, Bus Ducts, L.T. Riser Cables and L.T. Busbar Trunking

1.3.13.1 Vertical service shaft for electrical risers

For buildings over six-storey or 20 m high there shall, in general, be a minimum of one vertical electrical service shaft of (200 mm x 400 mm) size for every 1500 m² floor area. The electrical service shaft shall exclusively be used for the following purposes:

- (a) Electric supply feeder cables or riser mains
- (b) Busbar Trunking
- (c) telephone cables
- (d) Data Cables
- (e) fire alarm cables
- (f) CCTV cables
- (g) Other signal cables
- (h) Area fuse/circuit breakers
- (i) Floor Distribution board/sub-distribution boards for individual floors.

The construction of the floors of the duct area shall be constructed in such a way so that the remaining empty open space after putting the cables/busbar trunking/ pipes/ conduits in position is filled up with RCC slab(s) or any other non-inflammable material so that fire or molten PVC cannot fall from one floor to the next lower floor(s). For this purpose arrangements need to be made during floor casting.

Free and easy access to the electrical shaft room in each floor must be available for operation, maintenance and emergency shut downs.

Vertical cables other than electrical cables shall be placed at a sufficient distance from the nearest electrical cable. A vertical separating brick wall between electrical and non-electrical wall is preferable.

Vertical Service Shaft for Electrical Risers as mentioned above must not be placed adjacent to the Sanitary Shafts. They should be placed at significant separation in order to ensure that the Vertical Service Shaft for Electrical Risers remains absolutely dry.

1.3.13.2 LT Riser main cables

- (a) For low rise building riser main cables will serve to bring L.T. connection to the floor distribution boards (FDBs) of each floor from the main distribution board. For a 5 storied building or lesser having a floor space of less than 600 m² in each floor the riser cables may be PVC insulated cables through PVC or GI pipes.
- (b) For bringing the riser main cables a common vertical wall and holes or slots in the floors must be given by the building construction people.
- (c) However, for larger floor area or for higher buildings PVC insulated PVC sheathed underground cables must be used with protection and spacing.
- (d) For more than 9 storied building Busbar preferably sandwiched copper busbar trunking should be used for safety reasons.
- (e) PVC insulated PVC Sheathed underground cables must be used as Riser Main Cables. These cables shall be placed in or pulled through a PVC pipe of higher diameter so that the cable can be easily pulled through it. The PVC pipes must be fixed vertically in a straight line on the wall of the shaft using appropriate saddles. However, in some cases PVC insulated PVC Sheathed underground cables may be directly fixed on the wall using appropriate saddles with 37mm spacing between two adjacent cables. Sheet metal made Joint Boxes (with ebonite cover plates) must be placed at each floor tapping point.
- (f) The cable work shall be done neatly so that no suspended cables are seen around the place and no suspended flexible pipes are seen.
- (g) Each riser cable must have appropriate fuse or circuit breaker protection at the source busbar junction and also at the tap off point.

1.3.13.3 LT Busbar Trunking

For high rise buildings, LT (0.4KV TP&N) busbar trunking system is used instead of riser main cables to minimize space in the vertical electrical shaft, to minimize the risk of spreading of fire from one floor to another due to electrical short circuit in one of the cables or sparks, to have a neat distribution system. Most part of the busbar trunking shall be installed vertically. The horizontal portion of the busbar trunking shall usually connect the vertical portion with the Substation LT panel.

- (a) Busbar trunking are specially useful to minimize space and to minimize risks of spreading fire (during accidents) which may happen with bundles of insulated cables. The conductors supported by insulators inside the busbar trunking shall be copper of solid rectangular cross-section. The copper bars are insulated. A busbar trunking system shall be laid with minimum number of bends for distribution system. Typical rating of feeder busbar trunking for 3-phase- 3-wire or 3-phase- 4-wire system shall range from 200 amperes to 3000 amperes although lower amperes are not impossible.
- (b) Horizontal busbar trunking of suitable size may be provided along the roads for a group of buildings to be fed by a single substation but with heavy weather (moisture and water) protection and covered with appropriate weather resistant water proof material. Extreme care need to be taken in these cases for protection against moisture, water and outside weather.
- (c) Busbar trunking shall be placed in a dry place and must not be installed in a place which is even slightly exposed to weather/moisture/ spray or sprinkle of water.

1.3.13.4 LT Busducts

In certain applications, especially in factory lighting and factory power distribution of large area factories Busducts are used. In most cases, these Busducts are suspended from ceiling. Busducts offer safe, reliable, neat distribution system in these cases. The choice will depend on the floor area, type of machineries, type of jobs and other factors.

Appropriate circuit protection using adequate number of circuit breakers of appropriate rating is needed. In most cases these busducts are horizontally mounted/suspended. The busbars shall be copper. The rating shall depend on the current on each segment and the current carried by each segment.

1.3.14 L T Main Incoming Cable and Service Connection

(a) Overhead service connection to a building shall be achieved with PVC insulated Cables with GI support wire (similar to catenary) or catenary wire (mainly for single phase consumers). The overhead service connection shall be led into buildings via roof poles or service masts made of GI pipe at least 38 mm in diameter having a goose neck bend at the top and installed on the outer wall. The alternative is to have underground cable connection.

(b) Underground PVC insulated PVC sheathed water proof cables shall be placed in underground cable trench or pulled through a PVC pipe of higher diameter placed in a cable trench so that the cable can be easily pulled through it. PVC insulated stranded annealed copper ECC cables matching with the main cable size shall run along the Main incoming cable with termination at the earthing busbar at both end.

Each of the PVC pipes must have 18 SWG GI pull wires placed during laying of the pipes for pulling the cables later.

(c) For main incoming thick underground cables joints are strongly discouraged and should be avoided as far as possible. However, for unavoidable cases joints must be made through sleeve or ferrule of appropriately matched size fitted with hydraulic press following neat processing of the cable ends. Appropriate fusible heat shrink cover must be used over such junction.

For thick cables running through conduits as vertical risers, these joints must be put inside metal joint/pull boxes with covers.

(d) Special forms of construction, such as flame proof enclosures, shall be adopted where risk of fire or explosion exists near a place where thick incoming cable or riser cables are placed.

(e) The Underground service cable shall be laid in conformity with the requirements of Sec 1.3.24 titled “Laying of LT underground Cables”, of this Chapter.

(f) The power and telecommunication or antenna cables must be laid separately maintaining sufficient distance.

(g) The fire alarm and emergency lighting circuits shall be segregated from all other cables and from each other in accordance with BS 5839 and BS 5266. Telecommunication circuits shall be segregated in accordance with BS 6701 as appropriate.

(h) Where a wiring system is located in close proximity to a non-electrical service both the following conditions shall be met:

- The wiring system shall be suitably protected against the hazards likely to arise from the presence of the other service in normal use, and
- Appropriate protection against indirect contact shall be taken.

- (i) A wiring system shall not be installed in the vicinity of a service which produces heat, smoke or fume likely to be detrimental to the wiring, unless protected from harmful effects by shielding arranged so as not to affect the dissipation of heat from the wiring.
- (j) Where a wiring system is routed near a service liable to cause condensation (such as water, steam or gas services) precautions shall be taken to protect the wiring system from deleterious effects.
- (k) No cable shall be run in a lift (or hoist) shaft unless it forms part of the lift installation as defined in BS 5655.

1.3.15 Design for Electrical Wiring

Design of Electrical wiring must be done following the provisions provided in this Chapter. Detailed design drawings must be prepared by eligible Engineer for complete execution of the electrical works mentioned in this document and any other new items arising because of the evolution of new technologies in the near future.

Typically, there must be conduit layout drawing(s) indicating the conduit layouts, the locations of the switch boards, locations of the sockets, locations of the BDBs, locations of the SDBs, locations of the DBs, locations of the FDBs, location of the MDB, location of the Main incoming cable.

A distribution diagram of the BDBs, SDBs up to MDBs as applicable indicating the ampere rating of the incoming MCB/MCCB, interlinking cable sizes and the ECCs must be presented.

Detailed circuit diagrams of the circuits and the BDBs, SDBs, MDBs as applicable must be presented.

Detailed drawings of earthing and earth inspection pits and any other complicated parts must be presented. The contractor shall prepare as built drawings after completing a project.

1.3.15.1 Design for electrical wiring in bedrooms and drawing rooms

The location of a switch board must be near the entrance door of a bedroom like any other room. The location of the wall mounted light fittings must be chosen based on the possible locations of furniture which is also needed in other rooms. Sufficient number of 3-pin 13 A switched shuttered flat pin sockets must be provided in a bed room. The same principles are applicable for a Living room.

Design must be made in such a way that sufficient clearance (space) is left inside the concealed conduits (i) for the ease of pulling the cables and also for adding few more cables in case of necessity during future modification.

For bedrooms and drawing rooms the light plus fan sub circuits for shall not be of more than 5A rating.

Generally, single core PVC insulated stranded electrolytic annealed copper cables shall be used in concealed wiring technique or in the other methods.

1.3.15.2 Design for electrical wiring in a kitchen.

The sensitive item in a kitchen is placing 3-pin 13 A switched shuttered flat pin sockets on wall of the kitchen side table near the wall. Good distance must be maintained between the kitchen water tap and the socket. The socket for the refrigerator (if any) shall also be a 3-pin 13 A switched shuttered flat pin socket, and may be placed at the same level as the other socket. For the ease of operation a 3-pin 13 A switched shuttered flat pin socket for this purpose may be placed at the bottom level height of a switch board provided this is acceptable in terms of aesthetics.

For kitchens, the light plus fan sub circuits for shall not be of more than 5A rating.

1.3.15.3 Switches for toilets and bath rooms

Switches for toilet lights and toilet ventilating fans must be placed outside the toilets adjacent to the entrance door but must not be placed inside the toilet. The same rule should be followed for bath rooms. Using ceiling mounted chord switch at the entrance path of the door of a toilet is a good idea for small toilets attached to bed rooms. Ceiling mounted chord switches may be used with a chord suspended from the ceiling near the opening of the door.

1.3.15.4 Design for electrical wiring in office rooms

The location of a switch board must be near the entrance door of an office room. The location of the light fittings must be chosen based on the possible locations of work table, furniture. Sufficient number of 3-pin 13 A switched shuttered flat pin sockets must be provided in each office room. In this regard special consideration needs to be given on the possible location of computers and other office equipment.

Sufficient conduits and cables must be left for future modification as often rearrangement of cables needs to be made.

Generally, single core PVC insulated stranded electrolytic annealed copper cables shall be used for wiring by using the concealed wiring technique or the other two methods mentioned in the wiring section.

In case of special requirements, PVC insulated PVC sheathed Stranded Electrolytic Annealed Copper Cables may be used for wiring through conduits or other methods.

For Offices the sub circuits for shall not be of more than 5 A rating.

1.3.16 Temporary Electrical Connection for a Building Construction Site

Temporary connections are needed for a building construction site. A fuse distribution board containing incoming cut out fuse, outgoing cutout fuses plus busbars or distribution boards containing incoming circuit breakers, outgoing circuit breakers plus busbars of appropriate rating must be installed for such connections. Such boards shall be installed in a dry place so that rain water or waters coming from a construction zone cannot reach such boards.

1.3.17 Temporary Electrical Connection for an Outdoor Concert

Temporary connections are needed for an outdoor concert stage for special lighting, for various display systems, for high power audio systems. A fuse distribution board containing incoming cut out fuse, outgoing cutout fuses plus busbars or a distribution board containing incoming circuit breakers, outgoing circuit breakers plus busbars of appropriate rating must be installed for such connections. Such boards shall be installed in a dry place and shall be mounted at a safe height above ground so that rain water or waters coming from anywhere cannot reach such boards. Such boards shall not be installed near flammable materials.

Cables of appropriate types and appropriate ratings must be used for such applications.

Appropriate type of sockets, preferably flat 3-pin switched shuttered 13 A sockets should be used for distribution.

1.3.18 11 kV/ 0.4 kV Electrical Substation in a Building**1.3.18.1 General**

According to the rule of the distribution companies of Bangladesh, 11 kV/ 0.4 kV Electrical substations shall be required for a building if the load requirement of the building exceeds 50 kW. In most cases, substations are required for Multi-storied residential, Multi-storied Commercial buildings, Multi-storied Office building and Industries.

To determine the rating of the substation required, a load factor of at least 80% shall be applied to the estimated load of the building. The future expansion requirements should definitely be taken into consideration.

1.3.18.2 Location of an electrical substation

In a multi-storied building, the substation shall preferably be installed on the lowest floor level, but direct access from the street for installation or removal of the equipment shall be provided. The floor level of the substation or switch room shall be above the highest flood level of the locality. Suitable arrangements should exist to prevent the entrance of storm or flood water into the substation area.

The location of a substation will depend on (i) the feed point of the 11 kV Supply Authority line and (ii) the location of the LT vertical riser cables.

It is preferable to locate the air-conditioning plant room (if any) adjacent to the electrical substation in such a way that the distance from the controlling switchboard of the air-conditioning plant rooms and corresponding switches in the electrical substation are kept minimum.

In case of a building complex, or a group of buildings belonging to the same organization, the substation should preferably be located in a separate building and should be adjacent to the generator room, if any. Location of substation in the basement floor and on the floors above ground floor level (GFL) preferably be avoided. If Sub-Station it to be installed on the basement floor or the floors above ground floor level (GFL) special safety measures is to be taken by the user or owner. Measures are as follows:

- (i) No objection certificate stating the Sub-Station safe by the Fire Service and Civil Defense Department.
- (ii) Certification of the building consultant stating safe, proper ventilation, easy entrance and exit and safe load bearing capacity of the floors above the ground floor level (GFL).
- (iii) Proper undertaking of the Sub-Station user or owner as the case may be, Stating safety and liability will be ensured by them.

In case the electric substation has to be located within the main building itself for unavoidable reasons, it should be located on ground floor or assessment floor or the floors above the ground floor (GFL) with easy access from outside.

1.3.18.3 Height, area, floor level and other requirements of a substation room

- (a) The minimum height of a substation room should be 3.0 m to 3.6 m depending upon the size of the transformer.
- (b) The recommended area required for substation and transformer rooms for different capacities are given in Table 8.1.23 for general guidance. Minimum recommended spacing between the transformer periphery and walls should be :
 - (i) 0.75 m for Transformer installed in a room with wall on two sides.
 - (ii) 1.0 m for Transformer installed in a room with wall on three sides.
 - (iii) 1.25 m for Transformer installed in an enclosed room.
 - (iv) 1.5 m distance from one to another transformer for multiple transformers in room for 11 kV voltage level and 2.5 m distance for higher level of voltage.

- (c) For transformers having large oil content (more than 2000 litres), soak pits are to be provided.

The areas given in Table 8.1.23 hold good if they are provided with windows and independent access doors in accordance with local regulations.

All the rooms shall have significant ventilation. Special care should be taken to ventilate the transformer rooms and where necessary louvers at lower level and exhaust fans at higher level shall be provided at suitable locations in such a way that cross ventilation is maintained. Fans should be provided so that the transformer gets air supply from the fans.

The floor level of the substation should be high. Arrangement shall be made to prevent storm water entering the transformer and switch rooms through the soak pits, if floor level of the substation is low.

Substation of higher voltage may also be considered to the basement floor having proper and safe building design.

Table 8.1.23: Recommended Area for Transformer and Substation of Different Capacities

Capacity of Transformer (kVA)	Transformer Area (m ²)	Total Substation Area (with HT, LT Panels & Transformer Room but without Generators), (m ²)
1 × 150	12	45
1 × 250	13	48
2 × 250	26	100
1 × 400	13	48
2 × 400	30	100
3 × 400	40	135
2 × 630	26	100
3 × 630	40	190
2 × 1000	40	180
3 × 1000	45	220

1.3.18.4 11kV/0.4kV Distribution transformer for the substation of a building

An 11 kV/0.4kV indoor distribution Transformer is a major part of an indoor substation. These Substations may be installed inside the building itself or may be housed in a separate building adjacent to the building.

For small to moderate power rating up to 2 MW, two types of indoor transformers have been widely used in recent years. These are (i) Oil Type Natural Cooled transformer and (ii) Cast Resin Dry Type Natural Cooled transformers.

In most cases Oil Type Natural Cooled transformer may be used for substations if adequate space is available to accommodate the transformer.

Cast Resin Dry Type Natural Cooled transformers should be used (i) in places where stringent protection against spread of fire is needed and (ii) in places where space saving is of utmost importance.

Choice of oil type or dry type transformers

Dry type transformer should be installed where risk of spreading of fire is high and where flammable materials are to be kept around the substation.

For Hospital buildings, Multistoried Shopping Centers Dry type transformers should be used to for minimizing fire risks.

An industrial buildings containing inflammable materials, chemical and having the substation in the same building dry type transformers should be used for minimizing fire risks.

1.3.18.5 Type of connection between a substation transformer and its LT panel

Connection between a substation transformer and its LT panel can be established a) by using NYY underground LT Cables or b) by using ceiling suspended busbar trunking. For small size transformers the first method should be used although there is no restriction in using the second method. However, for big substations the second method is safer and at the same time gives a neat solution.

1.3.18.6 Ventilation of a substation

In an electrical substation significant amount of forced ventilation is very much needed apart from natural ventilation. Exhaust fans (minimum 450 mm dia) must be provided in sufficient numbers on all sides of the substation above the lintel level. Grill fitted windows having window panes must be provided on all sides for natural ventilation. The windows must have sun sheds so that no rain water can enter inside the substation.

If due to space constraint or due to any other difficulties, sufficient number of windows and ventilating fans cannot be installed, high velocity forced ventilation using ducts must be provided.

1.3.18.7 Layout of a substation

- (a) In general, substation HT to LT transformer shall be placed in one corner of the room so that the HT side remains away from the passage of the persons.
- (b) The HT metering panel shall be located near the exterior of the substation room near the exit gate and also shall be convenient for the HT cable entry.
- (c) The HT Panel shall be located near the exterior, just after or adjacent to the HT panel.
- (d) LT panel shall remain at a sufficient distance from the transformer but not too far away from the transformer. On the other hand, the location of the LT panel should be such that the riser main cable can have their way upward or outward within very short distance.
- (e) In allocating the areas within a substation, it is to be noted that the flow of electric power is from supply company network to HT room, then to transformer and finally to the low voltage switchgear room. The layout of the rooms shall be in accordance with this flow.
- (f) All the rooms shall have significant ventilation. Special care should be taken to ventilate the transformer rooms and where necessary louvers at lower level and sufficient number of high speed exhaust fans at higher level shall be provided at suitable locations in such a way that cross ventilation is maintained. Sufficient numbers of ceiling fans must be provided so that the transformer gets air supply from ceiling fans.
- (g) The 11 kV/0.4 kV substation shall not be placed in a basement.
- (h) The substation shall preferably be placed in ground floor. Placing a substation on any other floor other than ground floor shall be avoided.
- (i) The substation room and the areas adjacent to cable routes must have adequate fire alarm and fire extinguishing/fighting system appropriate for extinguishing fire due to electrical system, cable burning and oil burning.

1.3.19 Standby Power Supply

1.3.19.1 Provision for standby power supply

Provision should be made for standby power supply, in buildings, where interruption of electrical power supply would cause significant discomfort, result in interruption of activities, major production loss, cause hazard to life and property and cause panic. The standby power supply may be a petrol engine or diesel engine or gas engine generator or an IPS or a UPS.

1.3.19.2 Capacity of a standby generating set

The capacity of standby generating set shall be chosen on the basis of essential light load, essential air-conditioning load, essential equipment load and essential services load, essential lift (s), one or all water pumps and other loads required as essential load. Table 8.1.24 shows recommended room area for different sizes of generators as a general guidance. Minimum recommended spacing between the generator periphery and walls need to be included:

- (i) 1.0 m for generator installed in an enclosed room.
- (ii) 1.25 m distance from one to another generator for multiple generators in the room.

1.3.19.3 Generator room

The generating set should preferably be housed in the substation building or should be placed adjacent to the substation room to enable transfer of electrical load (Change over) with negligible voltage drop as well as to avoid transfer of vibration and noise to the main building. The generator room should have significant amount of ventilation and fitted with a number of ceiling fans. Appropriate type and number of firefighting equipment must be installed inside the generator room. The generator engine exhaust should be appropriately taken out of the building and should preferably be taken out through any other side except South. The generator oil tank should be placed away from the control panel side. In case of gas engine generator extra precaution must be taken regarding ventilation, leakage to prevent explosion.

The standby generator room should preferably be located outside the building. In the case of a gas engine driven generator, the generator must be located outside the building with adequate ventilation and windows. In general the generator room must have adequate ventilation and fans for continuous cooling.

The generator shall be placed either on the ground floor or in the first basement. Location of generator in the basement floor preferably be avoided. If generator is to be installed on the basement floor special safety measures is to be taken by the user or owner as per manufacturer's safety specification.

A continuous running generator must be located outside the building. Other rules mentioned above for standby generator are strictly applicable for this case.

For both the standby and continuous running generators the generator room and the areas adjacent to cable routes must have adequate fire alarm and fire extinguishing/fighting system appropriate for extinguishing fire due to cable burning and fuel burning. Generators must be installed on shock absorbing mounting bases.

1.3.19.4 Changeover switch of a generator

A standby generator, if needed, is to be connected at the supply input point after the energy meter and after the main incoming switch or the main incoming circuit breaker, but through a changeover switch of appropriate rating. The rating of such a switch shall be at least 1.25 times the rating of the main incoming circuit breaker. The changeover switch shall be of such a type so that when moved to the mains position, there is no chance that the generator will be connected and vice versa.

The Changeover Switch may be manual type with knife switch type switching or may be automatic type with magnetic contactors. In both the cases the Changeover Switch shall be properly made so that there is no chance of loose connection or spark.

The wiring for this purpose shall be made following the standard practices mentioned under the heading of wiring using cables of appropriate size.

Table 8.1.24: Recommended Area for Standby Generator Room

Capacity (kW)	Area (m ²)
1 × 25	20
1 × 48	24
1 × 100	30
1 × 150	36
1 × 300	48
1 × 500	56

1.3.19.5 Installation of an IPS or a UPS

- For safety purpose size of a UPS should be kept as small as possible.
- For the installation of a 200 - 600 VA IPS a 5A circuit must be made with the light points and fan points of different rooms to be brought under the control of the IPS. This circuit must have 3A Fuse protection using fuse cutout box. Wiring and connection has to be made following the wiring rules given in the wiring sections of this document. Cables of appropriate size must be used for wiring.
- For the installation of a 600 - 700 VA IPS a 5A circuit must be made with the light points and fan points of different rooms to be brought under the control of the IPS. This circuit must have 5A fuse protections or 5A circuit breaker protection. Wiring and connection has to be made following the wiring rules given in the wiring sections of this document. Cables of appropriate size must be used for wiring.

- (d) For the installation of an IPS of higher capacity, a BDB with multiple outgoing circuits each not exceeding 5 A shall be used with cutout - fuse protection at both incoming and outgoing sides. Cables of appropriate size must be used for wiring of each circuit.
- (e) Battery maintenance (checking water level, temperature rise and the condition of the terminals) should be done at least every 15 days. Connection of the Battery terminals should be made properly and checked periodically for loose connection and deposition of sulphate. Battery of an IPS must be kept in a safe place so that short circuit between the battery terminals does not occur. Inflammable materials must not be kept in the vicinity of the IPS or battery.
- (f) Safety issues must be taken into consideration in placing an IPS in a room. Same points shall apply for the installation of an UPS.

1.3.19.6 Installation of a solar photovoltaic system on top of a building

Building should be provided with solar photovoltaic system. For installation of a solar photovoltaic system, necessary precaution needs to be taken. Separate wiring and protection system must also be ensured.

Installation of solar water heaters on the roof tops of the residential and commercial buildings:

Buildings or apartments where hot water will be required, use of solar water heaters instead of electric and gas water heaters should be made mandatory. Flat plate heat collectors or vacuum tube solar water heaters of various capacities are available in the market.

The integral parts of a conventional solar photovoltaic system are:

- (a) Solar photovoltaic panel(s)
- (b) Battery charge controller
- (c) Inverter
- (d) Cables between the solar photovoltaic panel(s) and the battery charge controller
- (e) Cables between the battery and the battery charge controller
- (f) Cables between the inverter and the distribution board (DB/SDB/BDB)
- (g) Other cables and accessories.

For the installation of a solar photovoltaic system of higher capacity, a DB with multiple outgoing circuits each not exceeding 5 A shall be used with cutout - fuse protection at both incoming and outgoing side. Copper cables of appropriate size must be used for wiring of each circuit.

Battery maintenance (checking water level, temperature rise and the condition of the terminals) should be done at least every 15 days. Connection of the battery terminals should be made properly and checked periodically for loose connection and deposition of sulphate.

Batteries of a solar photovoltaic system must be kept in a safe place so that short circuit between the battery terminals does not occur. Inflammable materials must not be kept in the vicinity of the IPS or battery. In most cases for roof top solar panels, the battery room shall be placed inside a roof top room with adequate natural ventilation and forced cooling using ceiling fans. Because of the roof top location of the Solar panels, the room temperature is expected to be higher.

Safety issue must be taken into consideration in placing the batteries of a solar photovoltaic system.

For a residential flat system building, one or two circuits for each flat shall come from the DB of the photo-voltaic source at roof top to each flat depending on the requirement. Connection to load in each flat will be done through a changeover switch for each circuit.

For a commercial/office building, one or two circuits for each office/office area shall come from the DB of the photo-voltaic source at roof top to each flat depending on the requirement. Connection to load in each flat will be done through a changeover switch for each circuit.

Conduit based riser system must carefully be installed, separately for this system only, during the construction of the building to bring down the cables from the roof top DB room up to each flat/office/office area. Special care must be taken during installation so that rain water can under no circumstances get into the conduit and cable system.

1.3.19.7 Installation of a Solar Photovoltaic System on the exterior Glass of a Building having Large Glass area Facade

For semitransparent solar panels mounted on exterior glass of multistoried building similar process and precautions mentioned above must be followed.

1.3.20 Electrical Distribution System

1.3.20.1 Design, selection and choice of the type of connection

- (a) In the planning and design of an electrical wiring installation, due consideration shall be given to prevailing conditions. Advice of a knowledgeable and experienced electrical design engineer must be sought from the initial stage up to the completion of the installation with a view to have an installation that will prove adequate for its intended purpose, and which will be safe and will be efficient.
- (b) All electrical apparatus shall be suitable for the voltage and frequency of supply of this country mentioned earlier.

-
- (c) The number and types of connection required e.g., single-phase two-wire AC or three-phase four-wire AC shall be assessed, both for the supply source and for the internal circuits needed within the installation.
- (d) The following characteristics of the supply shall be ascertained :
- (i) nominal voltage(s)
 - (ii) current and frequency
 - (iii) prospective short circuit current at the origin of the installation
 - (iv) type and rating of the over-current protective device acting at the origin of the installation
 - (v) suitability for the requirements of the installation, including the maximum demand
 - (vi) expected maximum value of the earth loop impedance of that part of the system external to the installation.
- (e) In case of connected loads of 50 kW and above, HT 11 kV three-phase supply line with substation must be installed because of the requirement of the distribution companies although the use of HT supply will involve higher expenses due to installation of a distribution transformer, HT metering Panel, HT panel and LT Panel at the consumer's premises.

In this respect, the rules of the electrical distribution authorities will be the ultimate deciding factor.

1.3.20.2 Equipment and accessories

(a) High Voltage Switchgear

The selection of the type of high voltage switchgear for any installation should consider the following:

- (i) voltage of the supply system,
 - (ii) the prospective short circuit current at the point of supply,
 - (iii) the size and layout of electrical installation,
 - (iv) the substation room available, and
 - (v) the types machineries of the industry (if applicable).
- (b) Guidelines on Various Types of Switchgear Installation
- (i) Banks of switchgears shall be segregated from each other by means of fire resistant barriers in order to prevent the risk of damage by fire or explosion arising from switch failure. Where a bus-section switch is installed, it shall also be segregated from adjoining banks in the same way.

-
- (ii) In the case of duplicate or ring main supply, switches with interlocking arrangement shall be provided to prevent simultaneous switching of two different supply sources.
- (c) Low Voltage Switchgear
- (i) Switchgear and fusegear must have adequate breaking capacity in relation to the capacity of the transformers.
- (ii) Isolation and protection of outgoing circuits forming the main distribution system may be effected by means of circuit breakers, or fuses or switch fuse units mounted on the main switchboard. The choice between alternative types of equipment will take the following points into consideration:
- (iii) In certain installations supplied with electric power from remote transformer substations, it may be necessary to protect main circuits with circuit breakers operated by earth leakage trips, in order to ensure effective earth fault protection.
- (iv) Where large electric motors, furnaces or other heavy electrical equipment are installed, the main circuits shall be protected by metal clad circuit breakers or conductors fitted with suitable instantaneous and time delay overcurrent devices together with earth leakage and backup protection where necessary.
- (v) In installations other than those mentioned above or where overloading of circuits may be considered unlikely, HRC type fuses will normally afford adequate protection for main circuits separately as required; the fuses shall be mounted in switch fuse units or with switches forming part of the main switch boards.
- (vi) Where it is necessary to provide suitable connection for power factor improvement capacitors at the substation bus, suitable capacitors shall be selected in consultation with the capacitor and switchgear manufacturer and necessary switchgear/feeder circuit breaker shall be provided for controlling the capacitor bank(s).

1.3.21 Transformers

- (a) Where two or more transformers are to be installed in a substation to supply an LT distribution system, the distribution system shall be divided into separate sections each of which shall normally be fed from one transformer only unless the LT switchgear has the requisite short circuit capacity.
- (b) Provision may, however, be made to interconnect busbar sections through bus couplers to cater for the failure or disconnection of one transformer which need to be executed with much care using locking system.

- (c) The transformers, which at any time operate in parallel, shall be so selected as to share the load in proportion to their respective ratings. Appropriate protection must be provided and appropriate arrangements need to be made.
- (d) When a step-up transformer is used, a linked switch shall be provided for disconnecting the transformer from all poles of the supply, including the neutral conductor.

1.3.22 Precautions regarding Rotating Machines

- (a) All equipment including cables, of every circuit carrying the starting, accelerating and load currents of motors, shall be suitable for a current at least equal to the full load current rating of the motor. When the motor is intended for intermittent duty and frequent stopping and starting, account shall be taken of any cumulative effects of the starting periods upon the temperature rise of the equipment of the circuit.
- (b) The rating of circuits supplying the rotors of slip ring or commutator of a motor or an induction motor shall be suitable for both the starting and loaded conditions.
- (c) Every electric motor having a rating exceeding 0.376 kW shall be provided with control equipment incorporating means of protection against overcurrent.
- (d) Every motor shall be provided with means to prevent automatic restarting after a stoppage due to drop in voltage or failure. This requirement does not apply to any special cases where the failure of the motor to start after a brief interruption of the supply would be likely to cause greater danger. It also does not preclude arrangements for starting a motor at intervals by an automatic control device, where other adequate precautions are taken against danger from unexpected restarting.

1.3.23 LT Energy Meters

LT energy meters shall be installed in residential buildings at such a place which is readily accessible to the owner of the building and the Authority. Installation of digital energy meters at the users' premises is a requirement of the distribution Companies.

LT energy meters should be installed at a height where it is convenient to note the meter reading but should not be installed at a level less than 1.5 meter above the ground.

The energy meters should either be provided with a protective covering, enclosing it completely except the glass window through which the readings are noted, or shall be mounted inside a completely enclosed panel provided with hinged or sliding doors with arrangement for locking. Earthing terminal must be provided if a metal box is used. Such an earthing terminal must be connected to the ECC.

1.3.24 Laying of LT underground Cables

PVC-PVC NYY underground LT cables shall be laid using one of the three methods.

- (a) In the first method, brick wall prepared 900 mm deep trenches with cover plates shall be used for placing the cables at the bottom of the trench.
- (b) In the second method, 900 mm deep trenches prepared by ground excavation (underground direct burial method) shall be used for placing the cables on top of a 75 mm sand layer. In this second method (underground direct burial method), two layers of brick on top, marking tape and then back filling the trench will have to be done. The depth of the trench in general shall be 900 mm.
- (c) In the third method, pre-laid PVC pipes having sufficient clearance compared to the cable size (s) may be required at places. The PVC pipes must be laid in trenches of the 900 mm depth. For pre-laid PVC pipe ducts, brick wall made underground inspection pits will be required at an interval of at least 10 m for cable pulling and future extensions or alterations.

1.3.25 Laying of HT Underground Cables

The HT underground armoured cables shall be laid using one of the three methods.

In the first method (i) brick wall prepared 900 mm deep trenches with cover plates shall be used for placing the cables at the bottom of the trench.

In the second method, 900 mm deep trenches prepared by ground excavation (underground direct burial method) shall be used for placing the cables on top of a 75 mm sand layer. In this second method (underground direct burial method), two layers of brick on top, marking tape and then back filling the trench will have to be done. The depth of the trench in general shall be 900 mm.

In the third method, pre-laid PVC pipes having sufficient clearance compared to the cable size(s) may be required at places. The PVC pipes must be laid in trenches of the 900 mm depth.

For pre-laid PVC pipe ducts, brick wall made underground inspection pits will be required at an interval of at least 10 m for cable pulling and future extensions or alterations.

PVC pipe having sufficient clearance may be used for bringing the cable up to the trench of the metering panel or HT panel.

The PVC pipes must have 18 SWG GI pull wires placed during laying of the pipes for pulling the cables later.

Methods of installation of cables and conductors in common use are specified in Table 8.1.25.

1.3.26 Main Switch and Switchboards**1.3.26.1 Metal clad enclosed type**

All main switches shall be either metal clad enclosed type or of any other insulated enclosed type and the circuit breakers shall be fixed at close proximity.



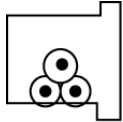

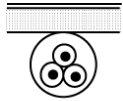
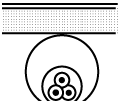
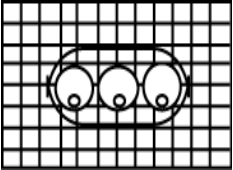
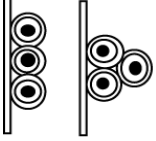
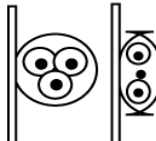


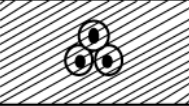

1.3.26.2 Circuit breakers on each live conductor

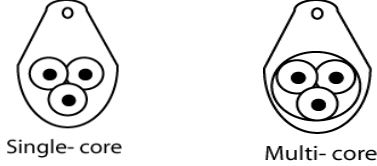
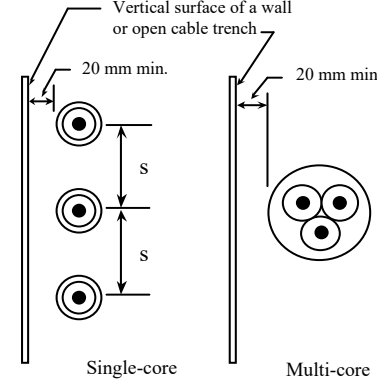
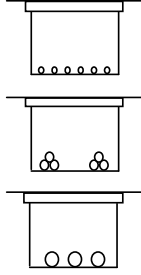
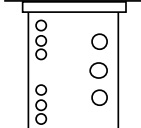
There shall be circuit breakers or miniature circuit breakers or load break switch fuses on each live conductor of the supply mains at the point of entry. The wiring throughout the installation shall be such that there is no break in the neutral wire in the form of a switch or fuse unit or otherwise.

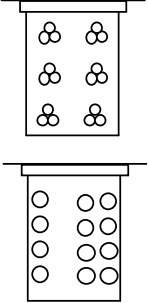
1.3.26.3 Location

- (a) The location of the main board shall be such that it is easily accessible for firemen and other personnel to quickly disconnect the supply in case of emergencies.
- (b) Main switchboards shall be installed in boxes or cupboards so as to safeguard against operation by unauthorized personnel.
- (c) Open type switchboards shall be placed only in dry locations and in ventilated rooms and they shall not be placed in the vicinity of storage batteries or exposed to chemical fumes.
- (d) In damp situation or where inflammable or explosive dust, vapour or gas is likely to be present, the switchboard shall be totally enclosed or made flame proof as may be necessitated by the particular circumstances.
- (e) Switchboards shall not be erected above gas stoves or sinks, or within 2.5 m of any washing unit in the washing rooms or laundries.
- (f) In case of switchboards being unavoidable in places likely to be exposed to weather, to drip, or in abnormally moist atmosphere, the outer casing shall be weather proof and shall be provided with glands or bushings or adapted to receive screwed conduit.
- (g) Adequate illumination shall be provided for all working spaces about the switchboards, when installed indoors.

Table 8.1.25: Different ways of Installation of Cables and Conductors in Common Use

Type	Description	Example	
A	Cables enclosed in conduit	 <p data-bbox="829 506 951 537">Single-core</p>	 <p data-bbox="1089 527 1211 558">Multi-core</p>
B	Cables enclosed in trunking	 <p data-bbox="829 682 951 709">Single Core</p>	 <p data-bbox="1089 682 1211 709">Multi-Core</p>
C	Cables enclosed in underground conduit, ducts, and cable ducting.	 <p data-bbox="829 829 951 856">Single-core</p>	 <p data-bbox="1089 829 1211 856">Multi-core</p>
D	Two or more single-core cables contained in separate bores of a multi-core conduit and intended to be solidly embedded in concrete or plaster or generally incorporated in the building structure.		
E	Sheathed cables clipped direct to a nonmetallic surface.	 <p data-bbox="813 1297 967 1325">Single-core</p>	 <p data-bbox="1065 1297 1219 1325">Multi-core</p>
F	Sheathed cables on a cable tray.	 <p data-bbox="797 1423 984 1451">Single-core</p>	 <p data-bbox="1065 1430 1219 1461">Multi-core</p>
G	Sheathed cables embedded direct in plaster.	 <p data-bbox="797 1612 984 1640">Single-core</p>	 <p data-bbox="1049 1612 1235 1640">Mutli-core</p>

Type	Description	Example
H	Sheathed cables suspended from or incorporating a catenary wire.	 <p>Single-core Multi-core</p>
J	Sheathed cables in free air. For cables in which the conductor cross-sectional area does not exceed 185 mm ² , S is equal to twice the overall diameter of the cable. For cables in which the conductor cross-sectional area exceeds 185 m ² , S is about 90 mm. For two cables in horizontal formation on brackets fixed to a wall, S may have any lesser value.	 <p>Vertical surface of a wall or open cable trench</p> <p>20 mm min. 20 mm min.</p> <p>S S</p> <p>Single-core Multi-core</p>
K	Single and multi-core cables in enclosed trench 450 mm wide by 600 mm deep (minimum dimensions) including 100 mm cover.	<p>Two single-core cables with surfaces separated by a distance equal to one diameter; three single-core cables in trefoil and touching throughout. Multi-core cables or groups of single-core cables separated by a minimum distance of 50 mm.</p> 
L	Single and multi-core cables in enclosed trench 450 mm wide by 600 mm deep (minimum dimensions) including 100 mm cover.	<p>Single-core cables arranged in flat groups of two or three on the vertical trench wall with surfaces separated by a distance equal to one diameter with a minimum separation of 50 mm between groups. Multi-core cables installed singly separated by a minimum* distance of 75 mm. All cables spaced at least 25 mm from the trench wall.</p> 

Type	Description	Example
M	Single and multi-core cables in enclosed trench 600 mm wide by 760 mm deep (minimum dimensions) including 100 mm cover.	<p>Single-core cables arranged in groups of two or three in flat formation with the surfaces separated by a distance equal to one diameter or in trefoil formation with cables touching. Groups separated by a minimum* distance of 50 mm either horizontally or vertically. Multi-core cables installed singly separated by a minimum* distance of 75 mm either horizontally or vertically. All cables spaced at least 25 mm from the trench wall.</p> 

* Larger spacing to be used where practicable.

1.3.27 Mounting of Metal clad switchgear

A metal clad switchgear shall be mounted on hinged type metal boards or fixed type metal boards.

- Hinged type metal boards shall consist of a box made of sheet metal not less than 2 mm thick and shall be provided with a hinged cover to enable the board to swing open for examination of the wiring at the back. The joints shall be welded. The board shall be securely fixed to the wall by means of rag bolt plugs, or wooden plugs and shall be provided with locking arrangement and an earthing stud. All wires passing through the metal board shall be protected by a rubber or wooden bush at the entry hole. The earth stud should be commensurate with the size of the earth lead(s).
- Fixed type metal boards shall consist of an angle or channel steel frame fixed on the wall at the top, if necessary.
- There shall be a clearance of one meter at the front of the switchboards.

1.3.28 Wooden Boards as Main Boards or Sub-Boards Containing Fused Cutouts and Main Switches

Use of Wooden Board is discouraged because of the fear of break out of fire from a spark or from an overheated cable. However, for small installations, not exceeding 15A SP, connected to a single-phase 230 V supply, wooden boards may be used as main boards or sub-boards containing fused cutouts and main switches of appropriate ratings may be used. Such a board shall be made using seasoned teak or other approved quality timber.

1.3.29 Location of Distribution Boards

The distribution boards shall be located as near as possible to the centre of the load they are intended to control.

- (a) They shall be fixed on suitable stanchion or wall and shall be accessible for replacement of fuses. All switches and circuit breakers used as switches shall be located so that they may be operated from a readily accessible place. They shall be installed such that the center of the grip of the operating handle of the switch or circuit breaker, when in its highest position, is not more than 2.0 m and the bottom of the panel shall be more than 0.45m above the floor or working platform.
- (b) They shall be either metal clad type, or all insulated type. But if exposed to weather or damp situations, they shall be of the weather proof type and if installed where exposed to explosive dust, vapour or gas, they shall be of flame proof type. In corrosive atmospheres, they shall be treated with anticorrosive preservative or covered with suitable plastic compounds.
- (c) Where two or more distribution fuse boards feeding low voltage circuits are fed from a supply of medium voltage, these distribution boards shall be:
 - (i) fixed not less than 2 m apart, or
 - (ii) arranged so that it is not possible to open two at a time, namely, they are interlocked, and the metal case is marked "Danger 415 Volts" and identified with proper phase marking and danger marks, or
 - (iii) installed in rooms or enclosures accessible to authorized persons only.
- (d) All distribution boards shall be marked "Lighting" or "Power", as the case may be, and also be marked with the voltage and number of phases of the supply. Each shall be provided with a circuit list giving diagram of each circuit which it controls and the current rating for the circuit and size of fuse element.
- (e) Distribution boards must be easily accessible for the ease of maintenance and switching off during accidents.

1.3.30 Over-current and Short Circuit Protection of Circuits

- (a) Appropriate protection shall be provided at the distribution boards for all circuits and sub-circuits against short circuit and over-current. The installed protective devices shall be capable of interrupting any short circuit current that may occur, without causing any danger. The ratings and settings of fuses and the protective devices shall be coordinated so as to obtain absolute certain discrimination of the faulty area only during a fault.
- (b) Where circuit breakers are used for protection of main circuit and the sub-circuits, discrimination in operation shall be achieved by adjusting the protective devices of the sub-main circuit breakers to operate at lower current settings and shorter time-lag than the main circuit breaker.
- (c) A fuse carrier shall not be fitted with a fuse element larger than that for which the carrier is designed.
- (d) The current rating of fuses shall not exceed the current rating of the smallest cable in the circuit protected by the fuse.

1.3.31 Fire Alarm and Emergency Lighting Circuits

Fire alarm and emergency lighting circuits shall be segregated from all other cables and from each other in accordance with BS 5839 and BS 5266. Telecommunication circuits shall be segregated in accordance with BS 6701 as appropriate.

1.3.32 Earthing**1.3.32.1 General**

Earthing refers to connecting the exposed conductive part of electrical equipment and also the extraneous conductive parts of earthed bodies like water pipe to the general mass of the earth to carry away safely any fault current that may arise due to ground faults. The object of an earthing system is to provide a system of conductors, as nearly as possible at a uniform and zero, or earth, potential. The purpose of this is to ensure that, in general, all parts of equipment and installation other than live parts shall be at earth potential, thus ensuring that persons coming in contact with these parts shall also be at earth potential at all times.

1.3.32.2 Earthing used in electrical installation for buildings

The usual method of earthing is to join the exposed metal work to earth via a system of earth continuity conductors (ECC) connected to an earth electrode buried in the ground through a system of earth lead wires. In conjunction with a fuse, or other similar device, this then forms a protective system.

Thus, if a live conductor accidentally comes into contact with an exposed metal, the fuse or protective device operates. As long as the overall resistance of the protective system is low, a large fault current flows which blows the fuse. This cuts off the supply and isolates the faulty circuit, preventing risk of shock, fire, or damage to equipment/ installation.

In Electrical installation for buildings, following types of earthing systems are required to be installed:

- (i) L.T. circuit/system earthing,
- (ii) Equipment earthing (LT side),
- (iii) Substation neutral earthing,
- (iv) Substation LT system earthing, and
- (v) H.T. circuit earthing for a substation.

The purpose of L.T. circuit/system earthing is to limit excessive voltage from line surges, from cross-overs with higher voltage lines, or from lightning, and to keep noncurrent carrying enclosures and equipment at zero potential with respect to earth.

Earthing the system helps facilitate the opening of overcurrent protection devices in case of earth faults. Earthing associated with current carrying conductors is normally essential for the protection and safety of the system and is generally known as circuit/ system earthing, while earthing of non-current carrying metal work and conductor is essential for the safety of human life, animals, and property and it is generally known as equipment earthing.

1.3.32.3 Arrangements of earthing systems:

- (a) The value of resistance from the consumer's main earthing terminal to the earthed point of the supply, or to earth, is in accordance with the protective and functional requirements of the installation, and expected to be continuously effective.
- (b) Earth fault currents and earth leakage currents likely to occur are carried without danger, particularly from the point of view of thermal, thermo-mechanical and electromechanical stresses.
- (c) Where a number of installations have separate earthing arrangements, protective conductors running between any two of the separate installations shall either be capable of carrying the maximum fault current likely to flow through them, or be earthed within one installation only and insulated from the earthing arrangements of any other installation.

1.3.32.4 Integral parts of an earthing system

The integral parts of an Earthing System are:

- (a) Earth electrode(s) buried under the ground
- (b) Earth lead cables/wires connecting the earth electrode(s) with the earthing busbar system. Earth lead cables/wires are also need to interconnect the earth electrodes when there are more than one earth electrode.
- (c) Earth continuity conductors (ECC) for linking earthing busbar at the substation LT panel or main distribution DB of a building.
- (d) Earth electrode clamp.

Connections of (i) Earth continuity conductors (ECC), (ii) Earth lead cables/wires and (iii) Earth electrode(s) must be made in appropriate and long lasting manner because poor connection or loss of connection will render the earthing system ineffective.

1.3.32.5 Earth continuity conductors (ECC)

ECC runs along the circuits/sub-circuits, socket circuits, interlinking circuits between a BDB and a SDB, between a SDB and a DB, between a DB and a FDB, between a FDB and a MDB, between a MDB and the LT panel earthing busbar of the substation. At each point an ECC shall be terminated in a copper earthing busbar. In metal switch boards back boxes and in metal socket back boxes appropriate copper or brass bolt nut termination shall be provided.

ECC of an earthing system joins or bonds together all the metal parts of an installation. PVC insulated wiring copper cables of appropriate size having Green + Yellow bi-colour insulation shall be used as ECC.

The minimum size of the ECC shall be same as cross-sectional area of the phase conductor for the PVC insulated wiring copper cables of appropriate size having Green + Yellow bi-colour insulation.

1.3.32.6 Earth lead cable/wire

Earth Lead cable/wire runs between an earth electrode and the earthing busbar of the MDB/DB or between an earth electrode and the LT panel earthing busbar of the substation.

Often more than one earth electrodes are needed. In such a case duplicate earth lead cables/wires from each earth electrode must be brought to the MDB/DB or to the LT panel earthing busbar of the substation and properly terminated. In addition, in the case of multiple earth electrodes, they must be interlinked by additional earth lead cables/wires.

PVC insulated wiring copper cables of appropriate size having Green + Yellow bi-colour insulation shall be used as earth lead wire. At both ends of the earth lead cable/wire, copper cable lugs must be fitted using crimp tools or hydraulic press.

The minimum size of the earth lead wire shall be 2 numbers of 1.5 mm² PVC insulated wiring copper cables of appropriate size having Green + Yellow bi-colour insulation.

The ends of the earth lead wires shall be terminated using crimp tool fitted cable lugs for fitting on the busbar or with the Earth Electrode Clamp.

- (a) An earth lead cable/wire establishes connection between the main earthing busbar and the earth electrode(s). The earth lead wire shall be brought to one or more connecting points, according to size of installation; the copper wire earthing leads shall run from there to the electrodes. Usually more than one earth lead wires are needed for one earth electrode to make sure that this link never fails.
- (b) Earth lead cable/ wires shall one of the following types:
- (i) PVC insulated cable
 - (ii) stranded copper cables without insulation
 - (iii) copper strips (copper bars)
 - (iv) PVC insulated cable is preferable in most cases.
 - (v) Earth lead wires shall run through PVC pipe from the earth electrode up to the earthing busbar of the MDB/DB or LT Panel.
- (c) Earth lead cables/ wires shall run, at least, 2 in parallel (at least) down to the earth electrode so as to increase the safety factor of the installation. The two cables shall be terminated in two separate cable lugs and bolts at both ends. Copper wire used as earthing lead must not be smaller than single core stranded 2 × 4 mm² PVC insulated cables (i.e. 2 nos. of single core 4 mm² PVC insulated cables in parallel). Depending on the current capacity of the Main incoming line the size will have to be raised.

Earth lead cables/wires shall be pulled from the earth electrode up to the terminating earthing busbar through PVC conduits or GI pipes of appropriate dimension.

Table 8.1.26: Minimum Cross-sectional Area of Copper ECCs in Relation to the Area of Associated Phase Conductors

Cross-sectional Area of Phase Conductor(s) (mm ²)	Minimum Cross-sectional Area of the Corresponding Earth Conductor (mm ²)
Less than 16	Same as cross-sectional area of phase conductor
16 or greater but less than 35	16 mm ²
35 or greater	Half the cross-sectional area of phase conductor

1.3.32.7 Earth electrodes and their installation

The earth electrode shall, as far as practicable, penetrate into moist soil (which will remain moist even during the dry season) preferably below ground water table. The resistance of an earthing system after measured after the installation of earth electrodes (individually or combined as a single group) shall be around one ohm.

The types of earth electrodes are to be used for earthing of electrical installations of a building and their sizes shall be as under:

- (a) Copper rod earth electrode: shall have a minimum diameter of 12.5 mm of minimum length of 3.33 m. Multiple copper rod earth electrodes may have to be installed to achieve an acceptable value of earthing resistance of around 1 ohm.
- (b) Copper plate earth electrodes: shall be 600 mm x 600 mm x 6 mm minimum in size. The copper plate shall be buried at least 2 m below the ground level. Multiple Copper plate earth electrodes may have to be installed to achieve an acceptable value of earthing resistance of around 1 ohm.
- (c) Galvanized Iron (GI) pipes: GI pipe earthing shall have a minimum diameter of 38 mm and of minimum length of 6.5m. Multiple GI pipes Earth Electrode may have to be installed to achieve an acceptable value of earthing resistance of around 1 ohm.

Schematic drawings of typical earthing systems are shown in Figures 8.1.2 to 8.1.4. For the installation of the earthing system the following points shall be considered.

- (a) For installing a copper rod earth electrode, a 38 mm GI pipe shall be driven below ground up to a depth of 5 m and shall be withdrawn. The 12 mm dia copper rod earth electrode of 4 m length shall then be easily driven into that hole up to a depth of 3.6 m and 0.33 m shall be left for placing inside the earthing pit described below.
- (b) For installing a 600 mm x 600 mm x 6 mm Copper plate 2 m below the ground level earth excavation will have to be done. The earth lead wire shall come via an earthing pit.
- (c) GI pipe earth electrodes driven by tube well sinking method are suggested. For this purpose 38 mm dia GI pipes are recommended for domestic buildings. For large plinth area buildings and multi-storied buildings 50 mm dia GI pipes are recommended. The length of GI pipe to be driven below the ground level depends on the earthing resistance which in turn depends on the availability of water table during the dry season in this country. However, except the high land and mountains, this depth varies between 12 m to 25 m.

- (d) Multiple numbers of GI pipe earth electrodes need to be used and connected in parallel in order to lower the earthing resistance measured with an earth resistance measuring meter. This is applicable for copper rod earthing and plate earthing also.
- (e) If multiple rod, pipe, or plate electrodes of one grounding system are installed to meet the earth resistance requirements, they shall not be less than 1.8 m apart. Two or more grounding electrodes that are bonded together shall be considered a single grounding electrode system.
- (f) If multiple rod, pipe, or plate electrodes of one grounding system are installed to meet the earth resistance requirements, they shall not be less than 1.8 m apart. Two or more grounding electrodes that are bonded together shall be considered a single grounding electrode system.

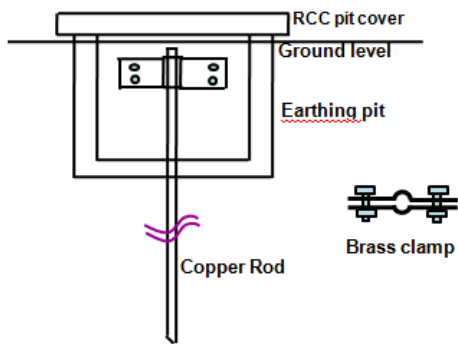


Figure 8.1.2 Copper Rod Earthing

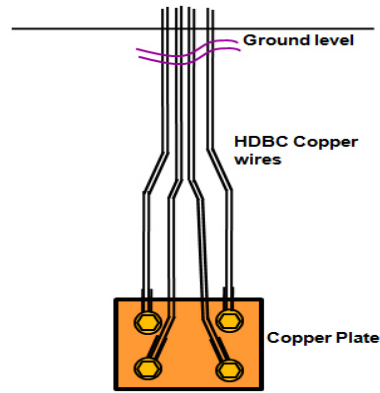
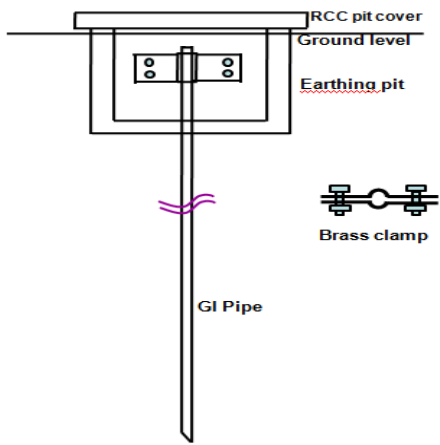
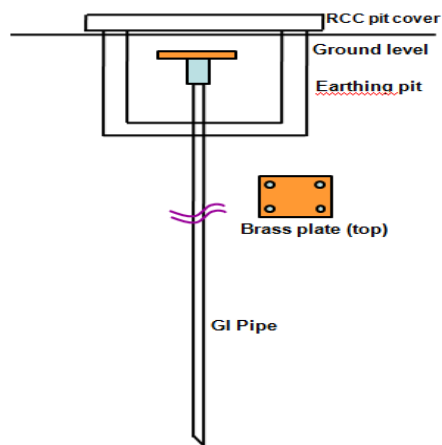


Figure 8.1.3 Copper Plate Earthing



(a)



(b)

Figure 8.1.4 Pipe Earthing; (a) Type 1; (b) Type 2

1.3.32.8 Brass clamps/terminals on earth electrodes (earth electrode clamp)

- (a) A brass clamp must be fitted on top of a GI pipe earth electrode to terminate the earth lead wire and to maintain electrical contact with the earth electrode and also to terminate the earth lead wire coming from the earthing busbar of the LT panel/ MDB/DB. This is needed to establish long lasting and firm connection between the earth electrode and earth lead wire, which in turn means connection between the earth electrode and earthing busbar of an LT panel or MDB/DB.
- (b) The Brass clamp shall be made using at least 9.5 mm thick and at least 50 mm wide Brass plate bent and shaped properly to fit tightly around the GI pipe earth electrode and shall have sufficient length (at least 35 mm) on both sides for fixing bolts and cable lugs. This clamp shall have two hexagonal head 9.5 mm bolts on one side and two hexagonal head 9.5 mm bolts on the other side, Figure 8.1.4(a). Sufficient space should be available for fixing the cable lugs of the earth lead wires. After fitting the lugs of the earth lead cables the brass clamp and the GI pipe head should be coated with two coats of synthetic enamel paint on top of one undercoat paint layer.
- (c) An alternative to this clamp is to use a 9.5 mm (at least) thick brass plate having 4 holes for fitting four hexagonal brass bolts on the four corners for fitting the cable lugs of the earth lead wires as shown in Figure 8.1.4(b). The brass plate is welded to a GI pipe socket and threaded on top of the earth electrode (pipe).

1.3.32.9 Earthing busbars

A copper earthing busbar shall be provided inside the LT Panel or MDB/DB of a building. The earth lead wire coming from the Earth Electrode (s) shall be terminated on this busbar using cable lugs (cable lugs must be fitted using crimp tools or hydraulic press) and brass bolts and nuts.

Copper earthing busbar shall also be provided inside the DBs, FDBs, SDBs and BDBs. Hexagonal head brass screw, nuts and washers are needed for fixing the ECC and earth lead cables with this busbar

1.3.32.10 Earthing pit

An earthing pit shall be constructed around the top of the Earth Electrode, below the ground level using 250 mm brick walls on a CC floor with a 150 mm thick RCC slab cover on top having lifting hooks. The top of the earth electrode (in case of pipe earthing) shall remain 375 mm above the top of the bottom CC floor of the pit. The minimum inside dimension of the earthing pit shall be 600 mm × 600 mm × 600 mm. The outside as well as the inside of the walls of the pit and the floor of the pit shall be cement mortar plastered. The inside shall be net cement finished. The top of the RCC slab pit cover shall remain 38 mm above the ground level. The pit shall be made in such a way that water cannot get in to the pit. One earthing pit is needed for one earth electrode.

1.3.33 Lightning Protection of Buildings

Whether a building needs protection against lightning depends on the probability of a stroke and acceptable risk levels. Assessment of the risk and of the magnitude of the consequences needs to be made. As an aid to making a judgment, a set of indices is given in Table 8.1.27 below for the various factors involved.

Table 8.1.27 (a): Index Figures Associated with Lightning Protection Design

Index A: Use of Structure	Index	Index B: Type of Construction	Index
Houses and similar buildings	2	Steel framed encased with nonmetal roof ^a	1
Houses and similar buildings with outside aerial	4	Reinforced concrete with nonmetal roof	2
Small and medium size factories, workshops and laboratories	6	Brick, plain concrete, or masonry with nonmetal roof	4
Big industrial plants, telephone exchanges, office blocks, hotels, blocks of flats	7	Steel framed encased or reinforced concrete with metal roof	5
Places of assembly, for example, places of workshop, halls, theatres, museums, exhibitions, department stores, post offices, stations, airports, stadiums	8	Timber formed or clad with any roof other than metal or thatch	7
Schools, hospitals, children's homes and other such structures	10	Any building with a thatched roof	10

^a A structure of exposed metal which is continuous down to ground level is excluded from the table as it requires no lightning protection beyond adequate earthing arrangements.

Table 8.1.27 (b): Index Figures Associated with Lightning Protection Design

Index C : Contents or Consequential Effects	Index	Index D : Degree of Isolation	Index
Ordinary domestic or office building, factories and workshops not containing valuable materials	2	Structure located in a large area having structures or trees of similar or greater height, e.g. a large town or forest	2
Industrial and agricultural buildings with specially susceptible ^b contents	5	Structure located in an area with a few other structures or trees of similar height	5
Power stations, gas works, telephone exchanges, radio stations	6	Structure completely isolated or exceeding at least twice the height of surrounding structures or trees	10
Industrial key plants, ancient monuments, historic buildings, museums, art galleries	8		
		Index E : Type of Terrain	Index
Schools, hospitals, children's and other homes, places of assembly	10	Flat terrain at any level	2
^b This means specially valuable plant or materials vulnerable to fire or the results of fire.		Hilly terrain	6
		Mountainous terrain 300 m and above	8

Table 8.1.27 (c) : Index Figures Associated with Lightning Protection Design

Index F : Height of Structure	Index	Index G : Lightning Prevalence	Index
Up to 9 m	2	Number of thunderstorm days per year:	
9-15 m	4	Up to 3	2
15-18 m	5	4-6	5
18-24 m	8	7-9	8
24-30 m	11	10-12	11
30-38 m	16	13-15	14
38-46 m	22	16-18	17
46-53 m ^c	30	19-21	20
^c Structures higher than 53 m require protection in all cases		Over 21	21

1.3.33.1 Degree of Isolation

The relative exposure of a particular building will be an element in determining whether the expense of lightning protection is warranted. In closely built-up towns and cities, the hazard is not as great as in the open country.

1.3.33.2 Type of terrain

In hilly or mountainous areas, buildings are more susceptible to damage due to lightning than buildings in the plains or flat terrain. In hilly areas, a building upon high ground is usually subject to greater hazard than one in a valley or otherwise sheltered area.

1.3.33.3 Height of structure

Height of the structure is an important factor for the purpose of lightning protection. Taller structures are subject to greater hazards than smaller structures and, therefore, lightning protection is more desirable for tall structures.

1.3.33.4 Lightning prevalence

The number of thunderstorm days in a year varies in different parts of a country. However, the severity of lightning storms, as distinguished from their frequency of occurrence, is usually much greater in some locations than others. Hence, the need for protection varies from place to place, although not necessarily in direct proportion to the thunderstorm frequency.

1.3.33.5 Risk assessment

"Risk Index" is the sum of the indices for all the factors, as given in Table 8.1.27. A few examples of calculation of Risk Index are given in Table 8.1.28, based on a marginal Risk Index of 40.

1.3.33.6 Integral parts of a lightning protection system

A smallest complete lightning protection system shall consist of (i) An air spike or air terminal, (ii) A down conductor, (iii) A roof conductor and (iv) An earth electrode.

An air spike or air terminal is that part which is intended to intercept lightning discharges. It consists of a vertical thick conductor of round cross section mounted on the highest part of the building to protect the required area. However, in general there may be more than one air spike or air terminal. In such a case roof conductors (made with copper strips or PVC insulated Annealed Stranded copper cables) need to be used to interconnect the Air Spikes or Air Terminals. Usually, for each Air Spike or Air Terminal there shall be one down conductor (made with copper strips or PVC insulated Annealed Stranded copper cables) going down up to the Earth Electrode pit and connected to the Earth Electrode. In all junctions, appropriate type of copper or brass junction plates or brass clamps must be used to ensure low resistance, firm and long lasting connection.

Table 8.1.28: Example of Calculation of Risk Index

Example	A	B	C	D	E	F	G	Total Index Figure	Recommendations
Small residential building in a thickly populated locality (height less than 10 m)	2	4	2	2	2	2	21	35	No protection needed, in general
Office building in a locality (height 20 m)	7	2	2	2	2	5	21	41	As the figure is around 40, need of protection will depend upon the importance of the building
Hotel building (height 31m) exceeding twice the height of surrounding structures	7	2	2	10	2	16	21	60	Protection essential
Building of historical importance completely isolated (height > 55 m)	8	4	8	10	2	30	21	83	Protection essential
Structure of high historical importance (height > 55 m)	-	-	-	-	-	-	-	-	Protection essential as the height exceeds 53 m
Structure, such as hydro-electric power stations, sufficiently protected by means of surrounding structures, for example, high vertical cliffs, high metallic structures or earth wire of transmission system (height 15 m)	7	2	6	2	6	4	21	48	Protected by surroundings

(a) Air spike/air terminal

An air spike or air terminal shall be made with copper rod of minimum 12 mm diameter with tin coating on top. The terminal shall have a copper/brass base plate for mounting on top of roof, column, parapet wall using rowel bolts. The minimum dimension of such a base plate shall be 152 mm x 152 mm x 13 mm. The length and width may need to be increased depending on the number of connection of the down conductors and the roof conductors. Such connections are to be made using hexagonal head brass bolts and nuts of 10mm diameter with brass washers. Minimum height of the air terminal shall be 300 mm above the highest point of the building fulfilling all the conditions of NFPA 780.

(b) Down conductor

A Down Conductor shall be made with copper strip or Stranded PVC insulated annealed copper cable.

(c) Roof conductor

A Roof Conductor shall be made with copper strip or Stranded PVC insulated annealed copper cable. This shall run along the periphery of the roof to link all air spikes and all down conductors installed on top of a building. The joints shall be made using clamps made of copper strips (of 1/8 inch minimum thickness) and appropriate brass bolts and washers of 3/8 inch minimum diameter.

(d) Earth electrode

The Earth Electrode is exactly of the same type as the Earth Electrode of the Electrical Distribution (Electrical Installation for Buildings) system described earlier in this document. Considering the practical situation in this country and Pipe Earth Electrodes are suggested. For each Air spike one Earth Electrode is an ideal solution.

(e) Earth inspection boxes

A 18 SWG GI sheet made Earth Inspection Box must be provided for each down conductor 1000 mm above the plinth level of the building (concealed inside the wall) which will contain a copper strip made clamp on the insulation peeled down conductor to check the continuity of the Earth Lead Down Conductor and the Earth Electrode and also to measure the Earth Resistance of the system. The box shall have a GI sheet made cover plate.

(f) Earthing pit

Earthing pits shall be provided as described in the earthing topic above.

1.3.33.7 Number of lightning arrestors required and their installation

Number of Lightning Protection Air Spikes in a building will depend on the nature of the roof top, on the total area of the roof top, on the height of the building, height of the adjacent buildings, height of the nearby towers or other similar structures. However, as a thumb rule, for every 80 m² area at least one air spike should be chosen at the beginning. During placement of the air spikes the total number may have to be increased or adjusted.

1.3.33.8 Protection zone

The zone of protection is the space within which an air spike provides protection by attracting the stroke to itself. It has been found that a single vertical conductor attracts to itself strokes of average or above average intensity which in the absence of the conductor would have struck the ground within a circle having its centre at the conductor and a radius equal to twice the height of the conductor. For weaker than average discharges the protected area becomes smaller. For practical design it is therefore assumed that statistically satisfactory protection can be given to a zone consisting of a cone with its apex at the top of the vertical conductor and a base radius equal to the height of the conductor. This is illustrated in Figure 8.1.5. A horizontal conductor can be regarded as a series of apexes coalesced into a line, and the zone of protection thus becomes a tent-like space (Figure 8.1.6).

- (a) When there are several parallel horizontal conductors the area between them has been found by experience to be better protected than one would expect from the above considerations only. The recommended design criterion is that no part of the roof should be more than 9 m from the nearest horizontal conductor except that an additional 0.3 m may be added for each 0.3 m or part thereof by which the part to be protected is below the nearest conductor.
- (b) The earth termination is that part which discharges the current into the general mass of the earth. In other words, it is one or more earth electrodes. Earth electrodes for lightning protection are no different from earth electrodes for short circuit protection systems. The total resistance of an electrode for a lightning protection system must not exceed 10 ohms for buildings up to 10 storied and 2 ohms for high rise buildings.

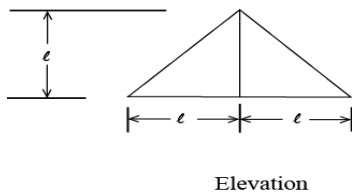


Figure 8.1.5 Protected zone for vertical conductors

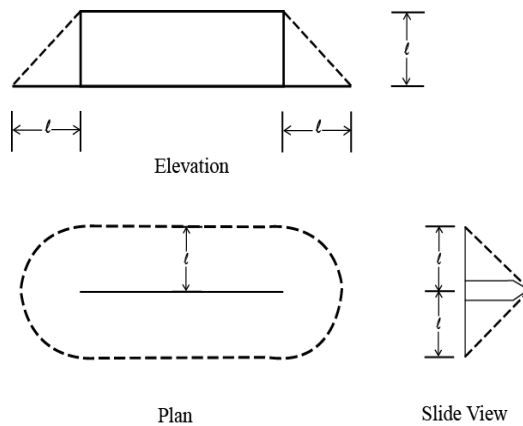


Figure 8.1.6 Protected zone for horizontal conductors

- (c) The down conductor is the conductor which runs from the air termination to the earth termination. A building with a base area not exceeding 100 m² shall be provided with one down conductor. For a larger building, there shall be one down conductor for the first 80m² plus a further one for every 100 m² or part thereof in excess of the first 80 m². Alternatively, for a larger building one down conductor may be provided for every 30 m of perimeter. Ideally, every air spike should have a down conductor going down up to the earth electrode.
- (d) The material used for lightning conductors must be copper. The criterion for design is to keep the resistance from air termination to earth electrode to a negligible value.
- (e) Recommended dimensions for various components of lightning arrester are given in Table 8.1.29. Larger conductors should however be used if the system is unlikely to receive regular inspection and maintenance.

Table 8.1.2 9: Sizes of the Components of Lightning Protection Systems

Components	Minimum Dimensions
Air terminals	12 mm dia
Copper strip	20 mm W x 3 mm T
Copper and phosphor bronze rods	12 mm dia
PVC insulated stranded annealed copper cable (minimum size)	19 strands of 1.8 mm dia
<u>Down Conductors</u>	
Copper strip	20 mm x 3 mm
PVC insulated stranded annealed copper cable (minimum size)	19 strands of 1.8 mm dia
<u>Earth Electrode</u>	
Hard drawn copper rods for driving into soft ground	12 mm dia
Hard drawn or annealed copper rods for indirect driving or laying in ground	12 mm dia
Phosphor bronze for hard ground	12 mm dia
Copper clad steel for hard ground	50 mm dia
GI pipe	38 mm/50 mm dia

- (f) External metal on a building should be bonded to the lightning conductor with bonds at least as large as the conductor.
- (g) When a lightning conductor carries a stroke to earth, it is temporarily raised to a potential considerably above that of earth. There is, therefore, a risk that the discharge will flash over to nearby metal and cause damage to the intervening structure. This can be prevented by either, (i) providing sufficient clearance between conductor and other metal or (ii) by bonding these together to ensure that there can be no potential difference between them. The necessary clearance is obtained from :

$$D = 0.3 R + \frac{H}{15 n} \quad (8.1.1)$$

Where,

D = Clearance in metres

R = Resistance to earth in ohms

H = Height of building in metres

n = Number of down electrodes

Since it is often impracticable to provide the necessary clearance, the alternative technique of bonding is preferred.

(h) Surge arrester selection

A surge arrester is a protective device for limiting surge voltages by discharging, or bypassing, surge current through it. It also prevents continued flow of follow-through current while remaining capable of repeating these functions. It is used to protect overhead lines, transformers and other electrical apparatus mostly in an outdoor substation from lightning voltages traveling through the overhead lines.

(i) Horn-gap lightning arresters

Horn-gap lightning arresters are commonly used for low and medium voltage overhead lines. The rating of the surge arrester shall be equal to or greater than the maximum continuous phase to ground power frequency voltage available at the point of application.

(j) Design of lightning arrester using rolling sphere method

Lightning arrester (including number and height) can also be designed and installed by using rolling sphere method following NFPA 780. Minimum height of the air terminal shall be in accordance with Sec 1.3.33.6.

1.3.34 Telecommunications in Buildings

1.3.34.1 General

Placing concealed 2 pair indoor cables is needed to get (i) telephone lines of the wired telephone companies inside rooms of a building and (ii) to get the PABX lines of the building /offices in the building to the respective rooms under the PABXs. In addition to this, 10/20/50 pair telephone cables are required to be brought in to the PABX room(s) of the building. Conduits are to be installed for both of these two categories. For the entry of 10/20/50 pair cables, conduits through straight and easy path (in most cases, through one side of the vertical electrical duct) need to be brought in.

1.3.34.2 Concealed telecommunication cable wiring

2 pair PVC insulated PVC sheathed annealed copper telecommunication cable shall be drawn through sufficient number of pre-laid 19/25/38 mm PVC conduits to establish telecommunication network inside a building. A clearance of at least 40 percent must be maintained inside the PVC conduits. Sufficient number of 18 SWG GI sheet made pull boxes (with Perspex sheet / ebonite sheet cover plates) at all suitable places must be placed for the ease of pulling these cables.

2 pair PVC insulated PVC sheathed annealed copper telecommunication cable shall be used for wiring between a Telephone DP/Patch panel and a telecommunication outlet. The extra pair shall remain for future maintenance. The minimum size of the copper wire of this cable shall be 0.5 mm. The copper shall be preferably tinned.

1.3.34.3 Surface telecommunication cable wiring

Surface wiring should not be a choice during designing a building wiring. However, if the building is already constructed or under compulsory conditions or for extension of an existing network one may go for surface wiring. The same 2 pair PVC insulated PVC sheathed annealed copper telecommunication cable shall be used for this purpose. Wiring shall be done either by using channels or by using PVC conduits following the power line surface wiring methods mentions earlier.

1.3.34.4 Telecommunications outlets

Wall mounted Telecommunication outlets shall contain RJ11 or RJ45 connectors/jacks (shuttered). For simple telephone connection RJ11 shuttered jacks are sufficient. The outlet box shall have a back-box which may be made of the same polymer material as the front panel or shall be made using 18 SWG GI sheet or 18 SWG MS sheet but painted with two coats of synthetic enamel paint.

1.3.34.5 Telephone DP room, patch panel room and digital PABX room

Telephone DP room, Patch Panel Room and PABX room should be located near the vertical riser duct of the building so that the incoming 50/100 pair underground telephone cable can be terminated in the DP/MDF or patch panel for distribution among the flats of a multistoried residential building or among the offices of a multistoried commercial/office building.

If a digital telephone PABX is to be installed then this can be installed in the same room. A separate earth electrode with earth lead wire will be required for the PABX.

1.3.35 Television Antennas/Cable Television system

In a multistoried residential/office building, television antennas shall be placed at one suitably sited antenna location on roof top and connect these to individual flats/residences/offices in the same building by coaxial cables through concealed conduits.

1.3.35.1 Cable work for television antennas/cable television system

Vertical duct and easy entry to each flats/ offices must be provided as sharp bending of these cables is difficult and harmful to the cables. These cables must not be placed in the same conduit with power cables. A distance of at least 350 mm must be maintained if a portion runs in parallel with the power cable conduits.

RF and Video cables shall be PVC sheathed Co-axial Cables shall be made with solid Copper centre conductor, foamed polythene insulated and further sealed Alluminium foil taped and Copper wire braided.

1.3.35.2 Television antenna outlets/cable television system outlets

Wall mounted television coaxial cable outlets shall contain high quality coaxial connectors/jacks. The outlet box shall have a back-box which may be made of the same polymer material as the front panel or 18 SWG GI sheet or 18 SWG MS sheet made but painted with two coats of synthetic enamel paint.

1.3.36 Data Communication Network for LAN and Internet Services inside a Building

Data Communication Network for LAN and Internet Services inside a Building may be installed using Cat 6 unshielded twisted pair (UTP) cables in a concealed manner following the concealed wiring power cables installation procedure mentioned in the wiring methods section of this document. Each of the cables will be terminated at one end at the 8P8C (RJ45) connector based data socket outlet board in the required rooms at the power socket level. On the other end, the cable will be terminated in the patch panel. From the patch panel up to the data socket outlet the cable shall be in one piece i.e., no

joints will be allowed. As a result the concealed conduit work needs to be done carefully to have a straight line path and without any bend in the roof slab. Sufficient pull boxes will be required in the roof slab. Pull box will also be needed close to the vertical bend near the bend and ceiling at any downward drop of the conduit. The conduits must have 20 SWG GI pull wires during laying for pulling the cables later.

Because of the nature of these cables more clearances are needed inside the PVC conduits compared to the power cables. If the conduits are running parallel to the power cables then there should be at least a distance of 410 mm between these two.

Recently Cat. 7 cables are emerging as a better choice in place of Cat. 6 cables.

1.3.37 Fire Detection and Alarm System inside a Building

The major parts of a Fire Detection and Alarm System inside a Building may be listed as

- (a) A number of different types of Fire Detectors/ detection devices wired in a number of radial circuits
- (b) Manual call points
- (c) A central control panel for fire detection
- (d) A number of alarm sounders/ alarm devices wired in a number of radial circuits
- (e) Cables for wiring the fire detectors/ detection devices
- (f) Cables for wiring the alarm sounders/ alarm devices

Control Panel

The control panel will indicate in which detection circuit (zone) an alarm or fault condition has been generated and will operate common or zonal sounders and auxiliary commands (for example door release or fire brigade signaling).

Detectors

A number of types of detectors (smoke detectors, heat detectors, ionization smoke detectors, optical beam smoke detectors, opto-heat detectors) for the installation

Alarm Devices

Alarm devices fall into two types, audible and visual. The audible types are most common, with a variety of types being available from bells to all kinds of different electronic sounders including those containing pre-recorded spoken messages. The choice of device is dependent on local preference, legal requirement and the need to have a tone distinct from all other building audible alarms.

Speech alarms or links to PA systems overcome some of the complacent responses to warning tones and can be used to good effect when carrying out regular fire tests in buildings where there are many people unfamiliar with the regular routines - such as hotels. Finally visual alarms are to be used where the hard of hearing may be occupying a building or where the ambient noise is such (above 90 dBA) that audible warning may not be heard, where hearing protectors are in use or where the sounder levels would need to be so high that they might impair the hearing of the building occupant.

Audible and Visual Alarm Devices

The audible types are most common, with a variety of types being available from bells to all kinds of different electronic sounders including those containing pre-recorded spoken messages. The choice of device is dependent on local preference, legal requirement and the need to have a tone distinct from all other building audible alarms.

Cables for Fire Detectors

BS 5839-1 introduced more onerous requirements for the types of cables used in fire detection and alarm systems. Fireproof cables should now be used for all parts of the system and enhanced fire resistance cables should be used where there is a requirement to ensure cable integrity over a longer period of time. For example when connecting to alarm sounders or where connection between sub-panels provides any part of alarm signal path.

Fire alarm cables should be segregated from the cables of other systems; they should be clearly marked, preferably coloured red and should be routed through parts of the building that provide minimum risk. This latter point is particularly relevant where the use of the building is being changed - for example if a fuel store is being moved.

Specific Areas of Application for Fire Detection and Alarm Equipment

The BS 5839 suite of standards relate to specific areas of application for fire detection and alarm equipment. Specifically part 1 relates to public premises and part 6 relates to residential premises. BS5839-1 is a comprehensive code of practice for fire detection and alarm systems, the requirements relate to both life and property protection and the standard includes much advice and comment which is very useful in informing the building owner or system specifier of the background to the requirements.

Codes of Practice for Different Types of Fire Protection Systems

The parts of BS7273 are codes of practice for different types of fire protection systems. Generally this is considered separately to fire alarm systems but there may be occasions where a tradeoff can be made between the two systems, or where the two systems interact and must be interfaced.

Standards Related to Design and Performance of Items of Equipment that Make up a Fire Detection and Alarm System

The EN 54 suite of standards relates to the design and performance of items of equipment that make up fire detection and alarm system. Each part relates to a different piece of equipment, for example part 3 relates to alarm devices, part 11 to call points, part 4 to power supplies etc.

Fire Detection Zones

Fire detection zones are essentially a convenient way of dividing up a building to assist in quickly locating the position of a fire. BS 5839-1 has some specific recommendations with respect to detection zones.

Wiring of the fire detection and alarm system will be done using the concealed wiring and the surface wiring methods described in the power line wiring section of this document.

1.3.38 CCTV System inside a Building

Installation of cable network for CCTV System inside a Building shall be done following the guidelines given for cable work for television antennas/cable television system earlier in this document.

For wiring of the power lines required for the Installation of CCTV system inside a building will be done using the concealed wiring and the surface wiring methods described in the power line wiring section of this document.

1.3.39 Design and Installation of Access Control System

Wiring of the Installation of access control systems will be done using the concealed wiring and the surface wiring methods described in the power line wiring section of this document.

1.3.40 Installation of Electronic Security Systems

Wiring of the installation of electronic security systems will be done using the concealed wiring and the surface wiring methods described in the power line wiring section of this document.

1.3.41 Qualification of the Contractor of Electrical and Electronic Engineering Works in a Building

A Contractor who will be working with the electrical and electronic engineering works in a building must have appropriate ABC license from the electrical licensing board of government of Bangladesh.

The contractor must have sufficient number of well trained and experienced technicians to execute the job. For big volume of work, the contractor must have at least one Electrical Engineer assigned for the job.

1.3.42 Inspection and Testing

1.3.42.1 General

Every installation shall, on completion and before being energized, be inspected and tested. The methods of test shall be such that no danger to persons or property or damage to equipment occurs even if the circuit tested is defective.

1.3.42.2 Periodic inspection and testing

Periodic inspection and testing shall be carried out in order to maintain the installation in a sound condition after putting it into service. Where an addition is to be made to the fixed wiring of an existing installation, the latter shall be examined for compliance with the recommendations of the Code.

1.3.42.3 Checking the conformity with the Bangladesh Standard

The individual equipment and materials which form part of the installation shall generally conform to the relevant Bangladesh Standard (BDS) wherever applicable. If there is no relevant Bangladesh standard specification for any item, these shall be approved by the appropriate authority.

(i) Inspection of the colour identification of cables of wiring

For single phase, Brown for Live, Blue for Neutral, Green + Yellow bi-colour for ECC. For three phase, Brown for L1, Black for L2, Grey for L3, Blue for Neutral and Green + Yellow bi-colour for ECC and Earth Lead Wire.

(ii) Inspection of earthing terminal, earthing bus

Inspection should be made to check whether brass made earthing terminals have been provided inside the metal back boxes of the switchboards and socket boards (welded or screwed to the metal back box) and whether the ECCs of the sub circuit have been terminated in these terminals. Inspection should be made to check whether at least one copper earthing busbar has been provided in the BDBs, SDBs, FDBs, DBs, MDBs and the LT panel and whether ECCs have been appropriately terminated in these busbars using hexagonal head brass bolt and nuts. Also it should be checked whether the Earth Lead Wires have been properly terminated in the LT Panel / MDB / DB as appropriate.

(iii) Insulation Tests

Insulation test is one of the most important tests for Electrical Installations in a Building.

Insulation resistance test shall be made on all electrical equipment, using a self-contained instrument such as the direct indicating ohm-meter of the generator type. DC potential shall be used in these tests and shall be as follows or an appropriate Meggar:

Circuits below 230 volts	500 volts Meggar
Circuits between 230 volts to 400 volts	1000 volts Meggar

The minimum acceptable insulation resistance value is 5 mega ohms for LT lines. Before making connections at the ends of each cable run, the insulation resistance measurement test of each cable shall be made. Each conductor of a multi-core cable shall be tested individually to all other conductors of the group and also to earth. If insulation resistance test readings are found to be less than the specified minimum in any conductor, the entire cable shall be replaced.

All transformers, switchgears etc. shall be subject to an insulation resistance measurement test to ground after installation but before any wiring is connected. Insulation tests shall be made between open contacts of circuit breakers, switches etc. and between each phase and earth.

(iv) Earth Resistance Test and the Continuity Resistance Test

Earth resistance tests shall be made on the system, separating and reconnecting each earth connection using earth resistance meter.

The electrical resistance of the Earth Continuity Conductor of different segment shall be measured separately using sensitive digital Ohm meter or by means of resistance bridge instrument. The resistance of the Earth Lead Wire shall be measured from the earthing busbar of the LT Panel/MDB/DB and the earth electrode(s). The electrical resistance of any section shall not exceed 1 ohm.

Where more than one earthing sets are installed, the earth resistance between two sets shall be measured by means of sensitive digital Ohm meter or by means of resistance bridge instrument. The earth resistance between two sets shall not exceed 1 ohm.

Operation Tests

Current load measurement shall be made on equipment and on all power and lighting feeders using Clamp on Ammeters.

The current reading shall be taken in each phase wire and in each neutral wire while the circuit or equipment is operating under actual load conditions.

Clamp on Ammeters are required to take current readings without interrupting a circuit.

All light fittings shall be tested electrically and mechanically to check whether they comply with the standard specifications.

Fluorescent light fittings shall be tested so that when functioning no flickering or choke singing is felt.

(v) Inspection of the Installation

On completion of wiring a general inspection shall be carried out by competent personnel in order to verify that the provisions of this Code and that of the Electricity Act of Bangladesh have been complied with. A certificate may be issued on satisfactory completion of the work in a format as shown in Appendix C. Items to be inspected are detailed in the following sections.

Inspection of Substation Installations

In substation installations, it shall be checked whether:

- The installation has been carried out in accordance with the approved drawings;
- Phase to phase and phase to earth clearances are provided as required;
- All equipment are efficiently earthed and properly connected to the required number of earth electrodes;
- The required ground clearance to live terminals is provided;
- Suitable fencing is provided with gate with lockable arrangements;
- The required number of caution boards, firefighting equipment, operating rods, rubber mats, etc., are kept in the substation;
- In case of indoor substation sufficient ventilation and draining arrangements are made;
- All cable trenches have covers of nonflammable material;
- Free accessibility is provided for all equipment for normal operation;
- All name plates are fixed and the equipment are fully painted;
- All construction materials and temporary connections are removed;
- Oil level, busbar tightness, transformer tap position, etc. are in order;
- Earth pipe troughs and cover slabs are provided for earth electrodes/earth pits and the neutral and LA earth pits are marked for easy identification;

- Earth electrodes are of GI pipes or CI pipes or copper plates. For earth connections, brass bolts and nuts with lead washers are provided in the pipes/plates;
- Earth pipe troughs and oil sumps/pits are free from rubbish, dirt and stone jelly and the earth connections are visible and easily accessible;
- HT and LT panels and switchgears are all vermin and damp-proof and all unused openings or holes are blocked properly;
- The earth busbars have tight connections and corrosion free joint surfaces;
- Control switch fuses are provided at an accessible height from ground;
- Adequate headroom is available in the transformer room for easy topping-up of oil, maintenance, etc.;
- Safety devices, horizontal and vertical barriers, busbar covers/shrouds, automatic safety shutters/door interlock, handle interlock etc. are safe and in reliable operation in all panels and cubicles;
- Clearances in the front, rear and sides of the main HT and LT and subswitch boards are adequate;
- The switches operate freely; the 3 blades make contact at the same time, the arcing horns contact in advance; and the handles are provided with locking arrangements,
- Insulators are free from cracks, and are clean;
- In transformers, there is no oil leak;
- Connections to bushing in transformers are tight and maintain good contact;
- Bushings are free from cracks and are clean;
- Accessories of transformers like breathers, vent pipe, buchholz relay, etc. are in order;
- Connections to gas relay in transformers are in order;
- In transformers, oil and winding temperature are set for specific requirements to pump out;
- In case of cable cellars, adequate arrangements exist to pump off water that has entered due to seepage or other reasons; and
- All incoming and outgoing circuits of HT and LT panels are clearly and indelibly labeled for identifications.

Inspection of Low Tension (LT) Installation

In Low Tension (LT) or Medium Voltage (MV) Installations, it shall be checked whether:

- All blocking materials that are used for safe transportation in switchgears, contactors, relays, etc. are removed;
- All connections to the earthing system have provisions for periodical inspection;
- Sharp cable bends are avoided and cables are taken in a smooth manner in the trenches or alongside the walls and ceilings using suitable support clamps at regular intervals;
- Suitable linked switch or circuit breaker or lockable push button is provided near the motors/apparatus for controlling supply to the motor/apparatus in an easily accessible location;
- Two separate and distinct earth connections are provided for the motor apparatus;
- Control switch fuse is provided at an accessible height from ground for controlling supply to overhead travelling crane, hoists, overhead busbar trunking;
- The metal rails on which the crane travels are electrically continuous and earthed and bonding of rails and earthing at both ends are done;
- Four-core cables are used for overhead travelling crane and portable equipment, the fourth core being used for earthing, and separate supply for lighting circuit is taken;
- If flexible metallic hose is used for wiring to motors and other equipment, the wiring is enclosed to the full lengths, and the hose secured properly by approved means;
- The cables are not taken through areas where they are likely to be damaged or chemically affected;
- The screens and armours of the cables are earthed properly;
- The belts of belt driven equipment are properly guarded;
- Adequate precautions are taken to ensure that no live parts are so exposed as to cause danger;
- Installed Ammeters and voltmeters work properly and are tested; and
- The relays are inspected visually by moving covers for deposits of dusts or other foreign matter.

Inspection of Overhead Lines

For overhead lines, every care must be taken so that:

- All conductors and apparatus including live parts thereof are inaccessible;
- The types and size of supports are suitable for the overhead lines/conductors used and are in accordance with approved drawing and standards;
- Clearances from ground level to the lowest conductor of overhead lines, sag conditions, etc. are in accordance with the relevant standard;
- Where overhead lines cross the roads suitable grounded guarding shall be provided at road crossings,
- Where overhead lines cross each other or are in proximity with one another, suitable guarding shall be provided at crossings to protect against possibility of the lines coming in contact with one another;
- Every guard wire shall be properly grounded/earthed;
- The type, size and suitability of the guarding arrangement provided shall be adequate;
- Stays cables must be provided suitably with the overhead line carrying poles as required and shall be efficiently earthed at the bottom and shall be provided with suitable stay insulators of appropriate voltages;
- Anti-climbing devices and Danger Board/Caution Board Notices are provided on all HT supports;
- Clearances along the route are checked and all obstructions such as trees/branches and shrubs are cleared on the route to the required distance on either side;
- Clearance between the live conductor and the earthed metal parts are adequate; and
- For the service connections tapped off from the overhead lines, cutouts of adequate capacity are provided.

Inspection of Lighting Circuits

The lighting circuits shall be checked to see whether:

- Wooden boxes and panels are avoided in factories for mounting the lighting boards, switch controls, etc.;
- Neutral links are provided in double pole switch fuses which are used for lighting control, and no fuse is provided in the neutral;
- The plug points in the lighting circuit are all 3-pin type, the third pin being suitably earthed;

- Tamper proof interlocked switch socket and plug are used for locations easily accessible;
- Lighting wiring in factory area is enclosed in conduit and the conduit is properly earthed, or alternatively, armoured cable wiring is used;
- A separate earth wire is run in the lighting installation to provide earthing for plug points, fixtures and equipment;
- Proper connectors and junction boxes are used wherever joints are in conductors or cross over of conductors takes place;
- Cartridge fuse units are fitted with cartridge fuses only;
- Clear and permanent identification marks are painted in all distribution boards, switchboards, sub-main boards and switches as necessary;
- The polarity has been checked and all fuses and single pole switches are connected on the phase conductor only and wiring is correctly connected to socket outlets;
- Spare knockouts provided in distribution boards and switch fuses are blocked;
- The ends of conduits enclosing the wiring leads are provided with ebonite or other suitable bushes;
- The fittings and fixtures used for outdoor use are all of weatherproof construction, and similarly, fixtures, fittings and switchgears used in the hazardous area are of flameproof application;
- Proper terminal connectors are used for termination of wires (conductors and earth leads) and all strands are inserted in the terminals;
- Flat ended screws are used for fixing conductor to the accessories;
- Flat washers backed up by spring washers are used for making end connections.

Accessibility of Connections and Cable joints for Inspection

Except for the following, every connection and joint shall be accessible for inspection, testing and maintenance:

- A compound-filled or encapsulated joint
- A connection between a cold tail and a heating element (e.g. a ceiling and floor heating system, a pipe trace-heating system)
- A joint made by welding, soldering, brazing or compression tool
- A joint forming part of the equipment complying with the appropriate product standard.

1.4 Related Codes and Standards

Significant modification, upgradation and additions of the previous electrical engineering section of BNBC of 1993 have been incorporated in this updated version. While making changes and additions, the following documents/regulations/codes have been taken as reference/guiding sources:

- (a) Bangladesh Electricity Act.
- (b) IEE wiring Regulation (17th edition) BS: 7671 2008 including all parts.
- (c) British Standards (BS).

In addition to these, the following documents/regulations/codes have also been taken as references as required:

- (a) National Building Code of India - 2005.
- (b) Building Code of Pakistan - latest version.
- (c) National Electrical Code of USA.
- (d) International Electrotechnical Commission (IEC) Standards.
- (e) ISO 50001 Standard for Energy Management System.
- (f) Verband Deutscher Elektrotechniker (Association of German Electrical Engineers) (VDE).

However, efforts have been given to accept a significant part of rules and practices mentioned in IEE wiring Regulation (17th edition) BS: 7671 2008 including all parts with necessary modifications for our system and suitable for our country.

While preparing this document the following Standards and practices are kept in mind.

- (a) For having safe domestic electrical systems, domestic electrical installations shall be designed and installed according to the "fundamental principles" given in British Standard BS 7671 Chapter 13. These are similar to the fundamental principles defined in international standard IEC 60364-1. It is necessary to apply British Standard BS 7671 (the "Wiring Regulations"), including carrying out adequate inspection and testing to this standard of the completed works.
 - To meet the above mentioned requirements the following rules and guidance shall be followed.
 - The rules of the IEE wiring regulations (BS 7671), colloquially referred to as "the regs" (BS 7671: 2008, 17th Edition).;
 - The rules of an equivalent standard approved by a member of the European Economic Area (e.g., DIN/VDE 0100);

-
- (b) Guidance given in installation manuals that is consistent with BS 7671, such as the IEE On-Site Guide and IEE Guidance Notes 1 to 7.
- (c) Installations in commercial and industrial premises must satisfy the requirements set in Electricity at Work Regulations 1989 (UK) and must follow recognised standards and practices, such as BS 7671 "Wiring Regulations".

Apart from these, some modifications had to be made considering the weather and other local conditions, practices and previous experiences in this country.

1.5 List Of Related Appendices

Appendix A	Maximum Demand and Diversity
Appendix B	Useful Tables Relating to Conductor Sizes
Appendix C	Completion Certificate Form

PART VIII
Chapter 2
Air-Conditioning, Heating And Ventilation

2.1 General

2.1.1 Purpose

The purpose of this Chapter is to provide minimum standards for regulating and controlling the design, construction, installation, quality of materials, location, operation, performance, maintenance and use of air conditioning, heating and ventilation systems to ensure acceptable conditions of air inside the building required for human health, safety and welfare with energy conservation.

2.2 Scope

2.2.1 The provisions of this Code shall apply to erection, installation, alteration, repair, relocation, replacement, addition to, use and maintenance of any air-conditioning, heating and ventilation systems.

2.2.2 Additions, alterations, repairs and replacement of equipment or systems shall comply with the provisions for new equipment and systems except as otherwise provided in Sec 2.2.2.1.

2.2.3 Where, in any specific case, different sections of this Code specify different materials, methods of construction or other requirements, the most restrictive one shall govern. Where there is a conflict between a general requirement and a specific requirement, the specific requirement shall be applicable.

2.2.4 The regulations of this Code are not intended, and shall not be understood to permit violation of the provisions of other ordinances, regulations or official requirements in force.

2.3 Application

It shall be unlawful to install, extend, alter, repair or maintain air-conditioning, heating and ventilation systems in or adjacent to buildings except in compliance with this Code.

2.3.1 Existing Systems

Existing Installations: Air-conditioning, heating and ventilation systems in existence at the time of adoption of this Code may have their use, maintenance or repair continued if the use, maintenance or repair is in accordance with original design and location and no hazard to life, health or property has been created by such system.

Additions, Alterations or Repairs: Additions, alterations or repairs may be made to any air-conditioning, heating or ventilation system without requiring the existing system to comply with all the requirements of this Code, provided the addition, alteration or repair conforms to the requirements of a new system. Additions, alterations or repairs shall not make an existing system unsafe, create unhealthy or overloaded conditions.

Changes in Building Occupancy: Air-conditioning, heating and ventilation systems which are a part of any building or structure undergoing a change in use or occupancy, as defined in the Building Code, shall comply with all requirements of this Code which may be applicable to the new use, or occupancy.

Maintenance: All air-conditioning, heating and ventilation systems, materials and appurtenances, both existing and new, and all parts thereof shall be maintained in proper operating condition in accordance with the original design and in a safe and hazard free condition. All devices or safeguards which are required by this Code shall be maintained in conformance with this Code. The owner or the owner's designated agent shall be responsible for maintenance of the systems and equipment.

Moved Buildings: Air-conditioning, heating and ventilation systems of a building or a structure if moved to another premises shall comply the provisions of this Code for new installations.

2.3.2 Alternative Materials and Methods of Construction

The provisions of this Code are not intended to prevent the use of any material or method of construction not specifically prescribed by this Code, provided any such alternative material and/or method of construction has been approved and the use authorized by the Authority.

The Authority shall require that sufficient evidence or proof be submitted to substantiate any claims made regarding the use of alternatives.

2.3.3 Modifications

Whenever there are practical difficulties involved in carrying out any of the provisions of this Code, the Authority, within the limitations set forth in Part 2 may allow modifications for individual cases. The modifications shall be in conformity with the intent and purpose of this Code and that such modification shall not lessen health, life and fire safety requirements.

2.4 Terminology

This Section provides an alphabetical list of the terms used in and applicable in this Chapter of the Code. In case of any conflict or contradiction between a definition given in this Section and that in Part 1, the meaning provided in this Section shall govern for interpretation of the provisions of this Chapter.

ABSORPTION	A process whereby a material extracts one or more substances present in an atmosphere or mixture of gases or liquids accompanied by the material's physical and/or chemical changes.
ABSORPTION REFRIGERATING SYSTEM	A refrigerating system in which refrigerant gas evaporated in the evaporator is absorbed in the absorber by an absorbent solution. This also includes a generator for separation of refrigerant from the absorbent solution, a condenser to liquefy the refrigerant and an expansion device.
ADSORPTION	The action, associated with the surface adherence, of a material in extracting one or more substances present in an atmosphere or mixture of gases and liquids, unaccompanied by physical or chemical change.
AIR CHANGE	Introducing new, cleansed, or recirculated air to conditioned space, measured by the number of complete changes per unit time.
AIR TERMINALS	A round, square, rectangular, or linear air outlet or inlet device used in the air distribution system.
AIR, OUTSIDE	External air; atmosphere exterior to refrigerated or conditioned space; ambient (surrounding) air.
AIR, RECIRCULATED	The part of return air passed through the air-conditioner before being resupplied to the conditioned space. Also known as AIR, RETURN.
AIR, RETURN	See AIR, RECIRCULATED.
AIR-CONDITIONING	The process of treating air so as to control simultaneously its temperature, humidity, purity, distribution, pressure and air movement to meet the thermal requirements of the space.
AIR-HANDLING UNIT	Equipment comprised of cooling and/or heating coil and a blower or fan with electric motor used for the purpose of cooling/heating and distributing supply air to a room, space or area.
BLOWER	A fan used to force air under pressure.
BOILER	A closed vessel in which a liquid is vaporized.
BRINE	Any liquid cooled by the refrigerant and used for the heat transmission without a change in its state. This also includes chilled water.

CHIMNEY	Primarily a vertical shaft enclosing at least one flue for conducting flue gases to the outdoors.
COIL	A cooling or heating element made of pipe or tubing.
CONDENSER (Refrigerant)	A heat exchanger in which the refrigerant, compressed to a suitable pressure, is condensed to liquid by rejecting heat to an appropriate external cooling medium. When the condenser rejects heat to air, the condenser is termed as air cooled condenser. When the condenser rejects heat to water, the condenser is termed as water cooled condenser. When the condenser rejects heat to glycol (brine), the condenser is termed as glycol cooled condenser.
CONDENSING UNIT	A condensing unit is a complete set consisting of compressor(s) and condenser(s) with or without receiver. It may be air cooled or water cooled.
CONTROL	Any device for regulating a system or component in normal operation, manual or automatic.
COOLING TOWER	An enclosed device for evaporatively cooling water by contact with air.
DAMPER	A device for regulating the flow of air or other fluid.
DEHUMIDIFICAT ION	Condensation of water vapour from air by cooling below the dew point.
DEW POINT TEMPERATURE	The temperature at which condensation of moisture begins when the air is cooled at same pressure.
DRY BULB TEMPERATURE	The temperature of air as registered by a thermometer, taken in such a way as to avoid errors due to radiation.
DUCT SYSTEM	A continuous passageway for the transmission of air which, in addition to the ducts, may include duct fittings, dampers, plenums, grilles and diffusers.
ENERGY EFFICIENCY RATIO	The ratio between refrigeration capacity of a complete air conditioning unit in btu/hr with the power consumption in watt.
ENTHALPY	A thermal property indicating quantity of heat in the air above an arbitrary datum, in kilo joules per kg of dry air (or btu per pound of dry air).
EVAPORATIVE AIR COOLING	The removal of sensible heat from the air by the adiabatic exchange of heat between air and a water-spray or wetted surface, wherein the evaporating water absorbs the sensible heat of air.

EVAPORATOR (refrigerant)	A heat exchanger in which liquid refrigerant, after reducing its pressure (expansion), is evaporated by absorbing heat from the medium to be cooled.
EXFILTRATION	The phenomenon of inside air leaking out of an air conditioned space.
FAN	An air moving device comprising of a wheel or blade, and housing or orifice plate.
FAN, TUBEAXIAL	A propeller or disc type wheel within a cylinder and including driving mechanism supports for either belt drive or direct connection.
FILTER	A device to remove solid particles from a fluid.
FIRE DAMPER	A closure which consists of a normally held open damper installed in an air distribution system or in a wall or floor assembly and designed to close automatically in the event of a fire in order to isolate the conditioned space from the fire zone.
FIRE SEPARATION	A construction assembly that acts as a barrier against spread of fire and may not be required to have a fire resistance rating or fire protection rating.
GLOBAL WARMING POTENTIAL (GWP)	Global warming potential of a chemical compound is its relative contribution to global warming compared to Carbon Dioxide (CO ₂). Global warming can make our planet and its climate less hospitable and more hostile to human life. Thus it is necessary to reduce reduction in emission of greenhouse gases such as CO ₂ , SO _x , NO _x and refrigerants. Long atmospheric life time of refrigerants results in global warming unless the emissions are controlled. GWP values of some of the refrigerants are given below. The values indicated are for an integration period of 100 years.

Refrigerant	GWP values
R-11	4,000
R-12	2,400
R-22	1,700
R-123	0.02
R-134a	1,300
R-407A	2,000
R-407C	1,600
R-410A	1,890
R-744 (CO ₂)	1.00

HUMIDITY	Water vapour within a space.
HUMIDITY, RELATIVE	The ratio of partial pressure or density of water vapour in air to the saturation pressure or density, respectively, of water vapour at the same temperature.
HYDRONIC	Of, relating to, or being a system of heating or cooling that involves transfer of heat by a circulating fluid (as water or vapour) in a closed system of pipes.
INDOOR AIR QUALITY (IAQ)	Air quality that refers to the nature of conditioned air that circulates throughout the space/area where one works, lives, that is, the air one breathes when indoors. It not only refers to comfort which is affected by temperature, humidity, air movement and odors but also harmful biological contaminants and chemicals present in the conditioned space. Poor IAQ may be a cause of serious health hazard. Carbon dioxide has been recognized as the surrogate ventilation index.
INFILTRATION	The phenomenon of outside air leaking into an air conditioned space.
INSULATION, THERMAL	A material having a relatively high resistance to heat flow and used principally to retard heat flow.
INTEGRATED PART LOAD VALUE (IPLV)	It is the part-load efficiency figure of the chiller at the ARI 550/590 standard rating point, measured in kW/ton, according to the following standard formula $IPLV = \frac{1}{\frac{0.01}{A} + \frac{0.42}{B} + \frac{0.45}{C} + \frac{0.12}{D}}$ where, A = kW/ton at 100% load B = kW/ton at 75% load C = kW/ton at 50% load D = kW/ton at 25% load
MECHANICAL REFRIGERATION EQUIPMENT	A refrigerating system in which the gas evaporated in the evaporator is compressed by mechanical means usually by a compressor. This also includes condenser and expansion device.
NON-STANDARD PART LOAD VALUE (NPLV)	It is the part-load efficiency figure of the chiller at the rating conditions other than the ARI standard rating point but within prescribed limits. The rating points are actually values at which the chiller will actually be operating.
OVERALL HEAT TRANSFER COEFFICIENT (U)	The time rate of heat flow per unit area (normal to the flow) from the fluid on the warm side of a barrier to the fluid on the cold side, per unit temperature difference between the two fluids.

OZONE
DEPLETION
POTENTIAL
(ODP)

Ozone depletion potential of a chemical compound is its relative contribution to the depletion of the ozone layer compared to CFC-11. ODP values of some of the refrigerants are as follows

Refrigerant	ODP values
R-11	1.0
R-12	1.0
R-22	0.05
R-123	0.02
R-134a	0
R-407A	0
R-407C	0
R-410A	0

PACKAGED AIR
CONDITIONER

An encased assembly of equipment/machinery for thermal conditioning (cooling/heating) of air along with cleaning and circulation of air to maintain internal thermal environment of an air conditioned space. It includes a prime source of refrigeration for cooling and dehumidification with or without internal and external air distribution ducting. It may also include means for heating, humidifying and ventilating air. These units may be floor mounted, wall mounted or ceiling mounted type. They may provide free delivery or ducted delivery of conditioned air.

These machines are equipped with air cooled or water cooled condenser(s). These machines are equipped with reciprocating, rotary or scroll compressor(s).

PLENUM

An air compartment or chamber to which one or more ducts are connected and which forms part of an air distribution system.

POSITIVE
VENTILATION

The supply of outside air by means of a mechanical device, such as a fan.

PSYCHROMETRY

The science involving thermodynamic properties of moist air and the effect of atmospheric moisture on materials and human comfort. It also includes methods of controlling properties of moist air.

PSYCHROMETRIC
CHART

A chart graphically representing the thermodynamic properties of moist air.

REFRIGERANT	The fluid used for heat transfer in a refrigerating system, which absorbs heat at a low temperature and a low pressure of the fluid and rejects heat at a higher temperature and a higher pressure of the fluid, usually involving changes of phase of the fluid.
REHEATING	The process by which air, which has been cooled down in order to condense out part of the moisture it contains, is heated again in order to raise its temperature to a suitable level.
RETURN AIR GRILLE	These are fittings fixed at the openings through which air is taken out from the air-conditioned enclosure by an air-conditioning plant or unit.
ROOM AIR- CONDITIONER	A factory made, encased assembly designed as a self-contained unit primarily for mounting in a window or through the wall or as a console. It is designed to provide free delivery of conditioned air to an enclosed space, room or zone (conditioned space). It includes a prime source of refrigeration for cooling and dehumidification and means for the circulation and cleaning of air. It may also include means for heating, humidifying, ventilating or exhausting air.
SHADE FACTOR	The ration of instantaneous heat gain through fenestration with shading device to that through the fenestration without shading device.
SUPPLY AIR	The air that has been passed through the conditioning apparatus and taken through the duct system and distributed in the conditioned space.
SPLIT AIR CONDITIONER	A split package air conditioner is same as the packaged air conditioner excepting that the condenser or the condensing unit is built as a separate package for remote field installation and interconnecting refrigerant pipes between indoor unit and outdoor unit is considered as a package. The indoor units may be floor mounted, wall mounted, ceiling mounted (concealed) and may be free blow type or ducted type.
SUPPLY AIR DIFFUSERS/ GRILLES	These are fittings fixed at the openings through which air is delivered into the air-conditioned enclosure by an air-conditioning plant or unit.
TEMPERATURE, DRY BULB	The temperature of air as registered by a thermometer.
TEMPERATURE, WET BULB	The temperature at which water, by evaporating into air, may bring the air to saturation adiabatically at the same temperature. Wet-bulb temperature (without qualification) is the temperature indicated by a wet bulb psychrometer constructed and used according to specifications.

THERMAL TRANSMITTANCE	Thermal transmission per unit time through unit area of the given building unit divided by the temperature difference between the air or some other fluid on either side of the building unit in 'steady state' conditions.
THERMAL ENERGY STORAGE	Storage of thermal energy, sensible, latent or combination thereof for use in central system of air conditioning or refrigeration. It uses a primary source of refrigeration for cooling and storing thermal energy for reuse at peak demand or for backup as planned.
VARIABLE REFRIGERANT FLOW (VRF) SYSTEM	A variable refrigerant flow (VRF) air conditioning system is similar to a split air conditioning system excepting that it is of larger capacity and covers multiple zones/areas simultaneously. It is consisted of one or more outdoor condensing units, multiple indoor units, interconnected refrigerant pipes between outdoor unit(s) and indoor units, etc. all considered as a single package. The condensing units contain at least one inverter controlled rotary/scroll compressor or digital scroll compressor. The objective of using inverter controlled compressor or digital scroll compressor is to regulate capacity of air conditioning system, in response to the load requirements, by regulating refrigerant flow through the indoor units. The indoor units may be floor mounted, wall mounted, ceiling mounted (concealed) and may be free blow type or ducted type.
VENTILATION	The process of supplying and/or removing air by natural or mechanical means to or from any space. Such air may or may not have been conditioned.
WATER CONDITIONING	The treatment of water circulating in a hydronic system, to make it suitable for air conditioning system due to its effect on the economics of the air conditioning plant. Untreated water used in air conditioning system may create problems such as scale formation, corrosion and organic growth. Appraisal of the water supply source including chemical analysis and determination of dissolves solids is necessary to devise a proper water conditioning program.

2.5 General Provisions

2.5.1 Air conditioning, heating and ventilation system shall be designed, constructed, installed, operated and maintained in accordance with good engineering practice such as described in the ASHRAE (American Society of Heating, Refrigerating and Air-conditioning Engineers) Handbooks, HI (Hydraulic Institute of USA) manuals and relevant chapters of this Code.

2.5.2 All electrical work in connection with air-conditioning, heating and ventilation system shall be carried out in accordance with the provisions of latest Bangladesh Electricity Act and the provisions of any of its regulations and bye-laws, and shall also comply with the requirements of Chapter 1.

2.5.3 All plumbing work in connection with air-conditioning, heating and ventilation system shall be carried out in accordance with the provisions and guidelines of ASHRAE handbooks and HI manuals.

2.5.4 All gas and fuel piping in connection with air-conditioning, heating and ventilation system shall be carried out in accordance with the provisions of Chapter 8.

2.5.5 Fire Safety: Installations of equipment of air-conditioning, heating and ventilation system shall conform to the requirements of Part 4 of this Code.

2.6 Planning

2.6.1 General

2.6.1.1 All relevant aspects of air-conditioning, heating and ventilation system installations shall be analyzed and evaluated properly during the planning stage of the building in order to determine the necessary provisions to be kept in the building for proper and safe installation of the system machinery, equipment and other facilities.

2.6.1.2 Necessary particulars of electrical requirements of air-conditioning, heating or ventilation system shall be determined early in the planning stage to include it in the electrical provisions of the building.

2.6.1.3 Where necessary, all plans, calculations, specifications and data for air-conditioning, heating and ventilation system serving all buildings and all occupancies within the scope of the Code shall be supplied to the Authority, for review purposes.

2.6.1.4 Design air conditioning, heating and ventilation system taking consideration for energy efficiency and energy conservation. Provide data to design architect to keep provisions in the building for reduction of energy usage required for operation of air-conditioning system. Optimize the design by coordinating the design with the design architect at the early stage i.e. in the schematic design phase and continually improve design during the design development process.

2.6.2 Building Planning

2.6.2.1 Orientation of building

Effect of orientation of building and arrangement of rooms/spaces shall be analyzed in the planning stage of the building to find out the most effective plan of the building in terms of building use, application of air-conditioning, heating and ventilation system and reduction of energy consumption.

2.6.2.2 Building design and use of materials

Analysis shall be carried out in the design stage for selection of appropriate shading devices and other materials as set forth in Sec 2.7.1 so as to take advantage of reduction in energy consumption related air-conditioning, heating and ventilation system. Selection of glazing materials shall be in compliance with Sec 2.12.2.4.

2.6.2.3 Equipment space

Requirements of space for erection and installation of air-conditioning, heating and ventilation system equipment and machinery (ducting, cooling, heating and air-conditioning equipment; refrigerating machinery, boiler etc.) shall be determined during the planning stage of the building so that it can be incorporated in the building planning effectively. Requirements of equipment/machinery space shall be determined taking consideration of actual equipment and machinery space; clearance space for operation; maintenance and fire prevention requirement; access space and other requirements of this Code. Building plan shall also include adequate provisions for transportation of equipment and machinery to and from equipment/machinery room, installation of outdoor air inlets and exhaust air outlets. Planning for equipment space shall take into consideration of different parameters described in Sections 2.5 and 2.6.

2.6.2.4 Equipment space planning for central air conditioning plant

- (a) In selecting the location for plant room, the aspects of efficiency, economy and good practice should be considered and wherever possible it shall be made contiguous with the building. This room shall be located as centrally as possible with respect to the area to be air conditioned and shall be free from obstructing columns.
- (b) In case of large capacity water cooled chiller installations (500 TR and above), it is advisable to have a separate isolated equipment room where possible. The clear headroom below soffit of beam should be minimum 4.5 m for centrifugal chillers, and minimum 3.6 m for reciprocating and screw type chillers.
- (c) The floors of the equipment rooms should be light colored and finished smooth. For floor loading, the air conditioning engineer should be consulted.
- (d) Supporting of pipe within plant room spaces should be normally from the floor. However, outside plant room areas, structural provisions shall be made for supporting the water pipes from the floor/ceiling slabs. All floor and ceiling supports shall be isolated from the structure to prevent transmission of vibrations.
- (e) Equipment rooms, wherever necessary, shall have provision for mechanical ventilation. In hot climate, evaporative air-cooling may also be considered.
- (f) Plant machinery in the plant room shall be placed on plain/reinforced cement concrete foundation and provided with anti-vibration supports. All foundations should be protected from damage by providing epoxy coated angle nosing. Requirements of seismic restraint supports may also be considered.
- (g) Equipment room should preferably be located adjacent to external wall to facilitate equipment movement and ventilation.
- (h) Wherever necessary, acoustic treatment should be provided in plant room space to prevent noise transmission to adjacent occupied areas.

- (i) Air conditioning plant room should preferably be located close to main electrical panel of the building in order to avoid large cable lengths.
- (j) In case the air conditioning plant room is located in basement floor, equipment movement route shall be planned to facilitate future replacement and maintenance. Service ramps or hatch in ground floor slab should be provided in such cases.
- (k) Floor drain channels or dedicated drainpipes in slope shall be provided within plant room space for effective disposal of waste water. Fresh water connection may also be provided in the air conditioning plant room.
- (l) Thermal energy storage: In case of central plants, designed with thermal energy storage its location shall be decided in consultation with the air conditioning engineer. The system may be located in plant room, on rooftop, in open space near plant room or buried in open space near plant room. For roof top installations, structural provision shall take into account load coming due to the same. For open area surface installation horizontal or vertical system options shall be considered and approach ladders for manholes provided. Buried installation shall take into account loads due to movement above, of vehicles, etc. Provision for adequate expansion tank and its connection to thermal storage tanks shall be made.

2.6.2.5 Space planning for air cooled chillers

- (a) Air Cooled chiller shall be installed where adequate open space is available for heat transfer of air cooled condensers of the chiller.
- (b) Where such space is available on ground, it can be installed on ground provided noise and hot air from the chiller do not create any problem to the adjoining building.
- (c) Roof of the building is a suitable location for installation of air cooled chiller. When it is intended to install air cooled chiller on roof, prior planning is a must. The roof shall be structurally strong enough to withstand the dynamic load of the chiller along with chilled water pumps, pipes, valves and associated equipment required for this purpose. Advice from an air conditioning engineer shall be taken at the planning stage.
- (d) Vibration from the machine shall not transmit to the roof structure. Chiller shall be installed on seismic restraint type vibration isolators.
- (e) Noise of the air cooled chiller shall be attenuated so that it does not transmit to the occupied area. A low speed condenser fan with acoustically treated fan cylinder shall be preferable. Similarly acoustically encased compressors shall also be preferable.

2.6.2.6 Planning equipment room for air handling units and package units

- (a) This shall be located as centrally as possible to the conditioned area and contiguous to the corridors or other spaces for carrying air ducts. For floor loading, air conditioning engineer shall be consulted.

-
- (b) In the case of large and multistoried buildings, independent air handling unit should be provided for each floor. The area to be served by air-handling unit should be decided depending upon the provision of fire protection measures adopted. Air handling unit rooms should preferably be located vertically one above another.
- (c) Provision should be made for the entry of fresh air. The fresh air intake shall have louvers having rain protection profile, with volume control damper and bird screen.
- (d) In all cases air intakes shall be so located as to avoid contamination from exhaust outlets or to the sources in concentrations greater than normal in the locality in which the building is located.
- (e) Exterior openings for outdoor air intakes and exhaust outlets shall preferably be shielded from weather and insects.
- (f) No air from any dwelling unit shall be circulated directly or indirectly to any other dwelling unit, public corridor or public stairway.
- (g) All air handling unit rooms should preferably have floor drains and water supply. The trap in floor drain shall provide a water seal between the air-conditioned space and the drain line.
- (h) Supply/return air duct shall not be taken through emergency fire staircase.
- Exception: Ducts can be taken inside the fire stair provided fire isolation of ducts at wall crossings is (are) carried out.
- (i) Waterproofing of air handling unit rooms shall be carried out to prevent damage to floor below.
- (j) The floor should be light colored, smooth finished with terrazzo tiles or the equivalent. Suitable floor loading should also be provided after consulting with the air conditioning engineer.
- (k) Where necessary, structural design should avoid beam obstruction to the passage of supply and return air ducts. Adequate ceiling space should be made available outside the air handling unit room to permit installation of supply and return air ducts and fire dampers at air handling unit room wall crossings.
- (l) The air handling unit rooms may be acoustically treated, if located in close proximity to occupied areas.
- (m) Access door to air handling unit room shall be single/double leaf type, airtight, opening outwards and should have a sill to prevent flooding of adjacent occupied areas. It is desired that access doors in air conditioned spaces should be provided with tight sealing, gaskets and self-closing devices for air conditioning to be effective.

- (n) Air handling unit rooms shall be separated from the air conditioned space by 4 hour fire rated walls and 2-hour fire rated door. Fire/smoke dampers shall be provided in supply/return air duct at air handling unit room wall crossings and the annular space between the duct and the wall should be fire-sealed using appropriate fire resistance rated material.
- (o) Fire isolation shall be provided for vertical fresh air duct, connecting several air handling units.

2.6.2.7 Planning of pipe shafts

- (a) The shafts carrying chilled water pipes should be located adjacent to air handling unit room or within the room.
- (b) Shaft carrying condensing water pipes to cooling towers located on roof/terrace should be vertically aligned.
- (c) All shafts shall be provided with fire barrier at floor crossings in accordance with the provisions of Chapter 4.
- (d) Access to shaft shall be provided at every floor.

2.6.2.8 Planning for supply air ducts and return air

- (a) Duct supports, preferably in the form of angles of mild steel supported using stud anchors shall be provided on the ceiling slab from the drilled hole. Alternately, duct supports may be fixed with internally threaded anchor fasteners and threaded rods without damaging the slabs or structural members.
- (b) If false ceiling is provided, the supports for the duct and the false ceiling shall be independent. Collars for grilles and diffusers shall be taken out only after false ceiling/boxing framework is done and frames for fixing grilles and diffusers have been installed.
- (c) Where a duct penetrates the masonry wall it shall either be suitably covered on the outside to isolate it from masonry or an air gap shall be left around it to prevent vibration transmission. Further, where a duct passes through a fire resisting compartment/barrier, the annular space shall be sealed with fire sealant to prevent smoke transmission (see also Part 4 of this Code).

2.6.2.9 Space planning for cooling tower

- (a) Cooling towers are used to dissipate heat from water cooled refrigeration, air conditioning and industrial process systems. Cooling is achieved by evaporating a small proportion of re-circulating water into outdoor air stream. Cooling towers are installed at a place where free flow of atmospheric air is available.

- (b) Cooling towers shall be installed at least 3 m above the bases of the chillers. Cooling tower shall preferably be installed on the roof of the concerned building. In special cases it may be installed on ground or on any elevated platform or on the roof of the adjacent building provided the moisture laden discharge air from the cooling towers do not pose any problem to other buildings. Cooling tower should be so located as to eliminate nuisance from drift to adjoining structures.
- (c) Any obstruction to free flow of air to the cooling tower shall be avoided.
- (d) Structural provisions for the cooling tower shall be taken into account while designing the building. Wind speed shall be taken into consideration while designing the foundations/supports for cooling towers. Vibration isolation shall be an important consideration in structural design.
- (e) Special design requirements are necessary where noise to the adjoining building is to be avoided. Special provisions shall be included in the design to reduce water droplet noise.
- (f) Provisions for make-up water tank to the cooling tower shall be made. Make-up water tank to the cooling tower shall be separate from the tank serving drinking water.
- (g) Make-up water having contaminants or hardness, which can adversely affect the refrigeration plant life, shall be treated.

2.6.2.10 Building structure

Structural design requirements viz. load on the floor or ceiling; punches in the roof, floor and walls; vertical shaft for pipe risers and duct risers; concrete ducts etc. shall be determined in the planning stage to make adequate provisions in the structural design and to keep such provisions in the building. The structural design shall consider static and dynamic loads of equipment and machinery including vibration of machinery.

2.6.2.11 Design drawings

For the purpose of effective installation of air-conditioning, heating and ventilation system, working drawings showing layout of machinery, equipment, ducts, pipes etc., details of builders' works, holes and/or punches in roof, floors, walls, supports for machinery/equipment etc. shall be prepared prior to finalization of building design drawings. Such drawings/documents shall be properly stored for future reference.

2.7 Air-Conditioning System Design

2.7.1 Building Design Requirements**2.7.1.1 Glazing**

- (a) Building design shall consider all the aspects for reduction of heat transfer through the glazing. Building orientation shall be such that, if possible, glazing in walls subject to direct and intensive sun exposure shall be avoided. In case where it is not possible to do so, necessary protective measures shall be taken to reduce heat transfer through the glazing. Such protective measures may be in the form of sun breakers, double glazing, heat resistant glass or application of other shading devices.
- (b) When sun breakers are used, it shall preferably be 1m away from the wall face, with free ventilation, particularly from bottom to top, being provided for cooling of sun breakers and window by free convection. Conduction from sun breakers to main building shall be the minimum. Sun breakers shall shade the maximum glazed area possible, especially for the altitude and azimuth angle of the sun. Sun breakers shall preferably be light and bright in colour so as to reflect back as much of the sunlight as possible.
- (c) Where the above protection is in the form of reflective surfaces, adequate care shall be taken to avoid any hazard to the traffic surrounding the building and people on the road because of the reflected light from the surfaces.
- (d) Application of any protection shall not restrict entry of light to a limit demanding artificial lights.

2.7.1.2 Roof insulation

- (a) Construction of exposed roofs shall be such that the heat transmission through the roof is not excessive. Where required the overall heat transfer coefficient (U) of the roof exposed to sun shall be reduced effectively by using appropriate construction materials and/or proper type of insulation material (s). The overall thermal transmittance from the exposed roof should be kept as minimum as possible and under normal conditions, the desirable value should not exceed $0.58 \text{ W/m}^2/^{\circ}\text{C}$.
- (b) Under-deck or over-deck insulation shall be provided for exposed roof surface using suitable Insulating materials. Over-deck insulation shall be properly waterproofed to prevent loss of insulating properties.
- (c) The ceiling surface of floors which are not to be air conditioned may be suitably insulated to give an overall thermal transmittance not exceeding $1.16 \text{ W/m}^2/^{\circ}\text{C}$.

2.7.2 Design Conditions**2.7.2.1 Inside design conditions**

- (a) For comfort air-conditioning, the inside design conditions shall be selected with an objective to reduce energy consumption in the operation of the air-conditioning system. Acceptable values of inside design conditions for summer are provided in Table 8.2.1. Unless otherwise specifically required, the design calculations shall be based on the normal practice values of Table 8.2.1.

Table 8.2.1: Inside Design Conditions of Some of Applications for Summer^a

Sl. No.	Use Category of Space	Indoor Design Conditions	
		Dry Bulb Temperature (°C)	Relative Humidity (%)
1.	Restaurants, Cafeteria and Dining Hall	23 ~ 26	55 ~ 60
2.	Kitchens	28 ~ 31	--
3.	Office buildings	23 ~ 26	50 ~ 60
4.	Bank/Insurance/Commercial building	23 ~ 26	45 ~ 55
5.	Departmental stores	23 ~ 26	50 ~ 60
6.	Hotel guest rooms	23 ~ 26	50 ~ 60
7.	Ball room/meeting room	23 ~ 26	40 ~ 60
8.	Class rooms	23 ~ 26	50 ~ 60
9.	Auditoriums	23 ~ 26	50 ~ 60
10.	Recovery rooms	24 ~ 26	45 ~ 55
11.	Patient rooms	24 ~ 26	45 ~ 55
12.	Operation theatres	17 ~ 27	45 ~ 55
13.	Delivery room	20 ~ 23	45 ~ 55
14.	ICU/CCU	20 ~ 23	30 ~ 60
15.	New born Intensive care	22.5 ~ 25.5	30 ~ 60
16.	Treatment room	23 ~ 25	30 ~ 60
17.	Trauma room	17 ~ 27	45 ~ 55
18.	Endoscopy/Bronchoscopy	20 ~ 23	30 ~ 60

Sl. No.	Use Category of Space	Indoor Design Conditions	
		Dry Bulb Temperature (°C)	Relative Humidity (%)
19.	X-ray (diagnostic & treatment)	25.5 ~ 27	40 ~ 50
20.	X-ray (surgery/critical area and catherization)	21 ~ 24	30 ~ 60
21.	Laboratory (diagnostics)	22.5 ~ 24.5	30 ~ 60
22.	Art Galleries/Museums	17 ~ 22	40 ~ 55
23.	Libraries	20 ~ 22	45 ~ 55
24.	Radio studio/Television studio	23 ~ 26	45 ~ 55
25.	Telephone terminal rooms	22 ~ 26	40 ~ 50
26.	Airport terminal/ bus terminal	23 ~ 26	50 ~ 60

Note:

^a The room design dry bulb temperature should be reduced when hot radiant panels are adjacent to the occupant and increased when cold panels are adjacent, to compensate for the increase or decrease in radiant heat exchange from the body. A hot or cold panel may be un-shaded glass or glass block windows (hot in summer, cold in winter) and thin partitions with hot or cold spaces adjacent. Hot tanks, furnaces, or machines are hot panels.

- (b) To avoid thermal shock, the difference between the dry bulb temperatures of outdoor air and indoor air shall not exceed 11°C. If it is absolutely necessary to have a difference more than 11°C, there shall have adequate provision for ante-room to reduce the effect of thermal shock.
- (c) For air-conditioning systems other than comfort air-conditioning, design conditions required by the specific processes involved or applications may be adopted. When required, proper protective measures shall be taken for persons working therein.
- (d) Velocity of air in an air-conditioned space, in the zone between the floor level and the 1.5 m level, shall be within 0.12 m/s and 0.25 m/s for comfort applications for commercial buildings, and for other applications it shall not exceed 0.5 m/s.

2.7.2.2 Outside design conditions

- (a) The outside design conditions for summer months for different cities are provided in Table 8.2.2. Selection of outside design conditions from this table shall be based on requirements of the application and the percent of time the outside air temperature is allowed to exceed the outside design conditions.

- (b) In case of stringent design conditions a meteorologist with experience in applied climatology may be consulted to evaluate conditions such as; the formation of heat sinks in urban areas; the duration of extreme temperatures; project sites located remotely from reporting stations.

2.7.2.3 Ventilation air

- (a) Every space served by the air-conditioning system shall be provided with outside fresh air not less than the minimum amount mentioned in Table 8.2.3. If adequate temperature regulation along with efficient filtration of air and absorption of odour and gas are provided, the amount of fresh air requirement may be reduced. However, in no case the outdoor air quantity shall be lower than 2.5 l/s per person.
- (b) In hospital operation theaters, a large quantity of outdoor air supply is recommended to overcome explosion hazard of anesthetics and to maintain sterile conditions. However, if adequate filtration with efficient absorption of anesthetics and laminar flow of supply air is provided, outside air requirement may be substantially reduced. Recirculation of air shall comply with the requirements of Sec 2.11.3.6.

2.7.3 Noise and Vibration

2.7.3.1 General

Air-conditioning, heating and ventilation system design and installations shall consider all the aspects of noise and vibration control related to the system and shall conform to the requirements of Chapter 3 of this Part. Selection and installation of equipment for air-conditioning, heating and ventilation system shall be such that noise and vibration transmitted to the space served by the system shall not exceed the recommended value for the space served.

2.7.3.2 Equipment room

Equipment room for installation of air handling units, refrigeration machinery, pumps, boilers, blowers and other equipment, which produce noise and vibration, shall not preferably be located adjacent to any acoustically sensitive area. Location of the equipment room shall be such that direct transmission of noise and vibration from the equipment room to acoustically sensitive areas do not occur. Appropriately designed sound barriers shall be used to restrict transmission of noise from equipment room to any acoustically sensitive areas, wherever necessary. Similarly, adequate measures shall be taken to restrict transmission of vibration from equipment room to other rooms.

2.7.3.3 Selection of equipment

Where possible, the equipment shall be selected which produce low sound power level consistent with the required performance and ensuring operation at maximum efficiency. Noise levels shall be reduced by appropriate shrouding of the equipment, if necessary. Equipment shall be so oriented that the noise will be radiated away from the likely areas of complaint.

Table 8.2.2: Outside Design Conditions for Different Stations^a

Station	Cooling DB/MWB ^b						Evaporation, WB/MDB ^c						Range of DB ^d
	0.4%		1%		2%		0.4%		1%		2%		
	DB	MWB	DB	MWB	DB	MWB	WB	MDB	WB	MDB	WB	MDB	DB ^d
(1)	(2)	(3)	(4)	(5)	(6)	(7)	(8)	(9)	(10)	(11)	(12)	(13)	(14)
Barisal	35.5	28.5	34.5	28.5	34.0	28.0	30.0	33.0	29.5	33.0	29.0	32.0	5.0
Bogra	36.5	28.5	35.5	28.5	34.5	28.0	31.5	33.5	30.0	33.0	29.0	33.0	5.5
Chandpur	35.5	28.5	34.5	28.5	34.0	28.0	29.5	33.0	29.5	33.0	29.0	32.5	5.0
Chittagong	34.0	28.5	33.5	28.5	33.0	28.0	29.5	32.5	29.0	32.5	28.5	32.0	4.5
Comilla	35.0	27.5	34.5	27.5	34.0	27.5	29.0	33.0	28.5	32.5	28.0	32.0	5.5
Cox's Bazar	34.0	27.5	33.5	27.5	33.0	27.5	29.0	31.0	29.0	30.0	29.0	30.0	5.0
Dhaka	35.55	27.5	35.0	27.0	34.5	27.0	29.0	33.0	28.5	29.0	28.5	29.0	5.0
Dinajpur	36.0	28.5	35.0	28.0	34.5	28.0	30.0	32.5	29.0	33.0	29.0	33.0	5.5
Faridpur	36.5	28.5	35.5	28.0	34.5	28.0	29.5	33.0	29.0	33.0	29.0	33.0	5.0
Ishurdi	37.5	27.0	36.5	27.0	35.5	28.0	30.0	34.5	29.0	33.5	29.0	33.5	6.0
Jessore	38.0	28.5	37.0	28.5	36.0	28.0	30.0	35.0	30.0	35.0	29.5	34.0	6.5
Khulna	36.5	29.0	36.0	28.0	35.5	28.0	30.0	34.0	30.0	34.0	29.5	33.5	5.0
Mongla	37.0	31.0	36.0	30.5	35.0	30.0	33.0	34.0	32.5	34.0	32.0	33.5	5.0
Mymensingh	35.0	28.0	34.0	28.0	33.5	27.5	29.5	33.0	29.0	32.5	28.5	32.0	4.5
Patuakhali	35.5	28.5	35.0	28.5	34.5	28.5	30.0	33.0	30.0	33.0	29.5	32.5	5.0
Rajshahi	35.5	29.0	34.5	28.5	34.0	29.0	31.5	33.0	31.0	32.5	30.0	31.5	5.0
Rangamati	35.5	26.0	34.5	27.0	34.0	27.5	28.5	33.5	28.0	32.5	28.0	32.5	6.0
Rangpur	35.5	28.5	34.5	28.0	34.0	28.0	29.5	30.5	29.5	30.0	29.5	30.0	5.0
Sylhet	35.5	27.0	34.5	27.0	34.0	26.5	28.5	32.5	28.0	32.5	28.0	32.5	5.5
Tangail	36.0	27.5	35.5	27.5	34.5	27.5	29.0	33.5	28.5	33.0	28.5	33.0	5.5

Notes:

a This table has been prepared by statistical analysis of weather data of ten years, recorded three hourly by trained observers of Bangladesh Meteorological Department.

b The dry bulb (DB) temperatures presented in column-2, 4 & 6 represent values which have equaled or exceeded by 0.4%, 1%, and 2% of the total hours during the summer months of May through September. The coincident mean wet bulb temperatures (MWB) listed in columns 3, 5 & 7 are the mean of all wet bulb temperatures occurring at the specific design dry bulb temperatures. These values shall be used for cooling load calculation.

c Wet bulb (WB) temperatures presented in column-8, 10 & 12 represent values which have been equaled or exceeded by 0.4%, 1% and 2% of the total hours during the summer months of May through September. The coincident mean dry bulb temperatures (MDB) listed in columns 9, 11 & 13 are the mean of all dry bulb temperatures occurring at the specific design wet bulb temperatures. These values shall be used for selection of Cooling Tower, evaporative cooling equipment, fresh air cooling and other similar equipment.

d Mean daily range temperatures presented in column-14 are the difference between the average daily maximum and average daily minimum temperatures during the warmest months at each station.

Table 8.2.3: Minimum Ventilation Rates for Air Conditioned Spaces

Occupancy Classification	Outdoor Airflow Rate in Breathing Zone	Outdoor Airflow Rate in Breathing Zone^a	Default Occupant Density^a	Exhaust Airflow Rate^a
	<i>l/s per person</i>	<i>l/s per m²</i>	<i>No./100 m²</i>	<i>l/s per m²</i>
Correctional facilities				
Cells without plumbing fixtures	2.5	0.6	25	-
Cells with plumbing fixtures ^g	2.5	0.6	25	5.0
Dining halls	(see food and beverage service)			
Guard stations	2.5	0.3	15	-
Day room	2.5	0.3	30	-
Booking/waiting	3.75	0.3	50	-

Occupancy Classification	Outdoor Airflow Rate in Breathing Zone	Outdoor Airflow Rate in Breathing Zone^a	Default Occupant Density^a	Exhaust Airflow Rate^a
	<i>l/s per person</i>	<i>l/s per m²</i>	<i>No./100 m²</i>	<i>l/s per m²</i>
Dry cleaners, laundries				
Coin-operated dry cleaner	3.75	-	20	-
Coin-operated laundries	3.75	0.3	20	-
Commercial dry cleaner	15	-	30	-
Commercial laundry	12.5	-	10	-
Storage, pick up	3.75	0.6	30	-
Education				
Auditoriums	2.5	0.3	150	-
Corridors		(see public spaces)		
Media center	5	0.6	25	-
Sports locker rooms ^g	-	-	-	2.5
Music/theater/dance	5	0.3	35	-
Smoking lounges	30		70	-
Day care (through age 4)	5	0.9	25	-
Classrooms (ages 5-8)	5	0.6	25	-
Classrooms (age 9 plus)	5	0.6	35	-
Lecture classroom	3.75	0.3	65	-
Lecture hall (fixed seats)	3.75	0.3	150	-
Art classroom ^g	10	0.9	20	3.5
Science laboratories ^g	5	0.9	25	5.0
Wood/metal shops ^g	5	0.9	20	2.5
Computer lab	5	0.6	25	-
Multiuse assembly	3.75	0.3	100	-
Locker/dressing rooms ^g	-	-	-	1.25

Occupancy Classification	Outdoor Airflow Rate in Breathing Zone	Outdoor Airflow Rate in Breathing Zone^a	Default Occupant Density^a	Exhaust Airflow Rate^a
	<i>l/s per person</i>	<i>l/s per m²</i>	<i>No./100 m²</i>	<i>l/s per m²</i>
Food and beverage service				
Bars, cocktail lounges	3.75	0.9	100	-
Cafeteria, fast food	3.75	0.9	100	-
Dining rooms	3.75	0.9	70	-
Kitchens (cooking) ^b	-	-	-	3.5
Hospitals, nursing and convalescent homes				
Autopsy rooms	-	-	-	2.5
Medical procedure rooms	7.5	-	20	-
Operating rooms	15	-	20	-
Patient rooms	12.5	-	10	-
Physical therapy	7.5	-	20	-
Recovery and ICU	7.5	-	20	-
Hotels, motels, resorts and dormitories				
Multipurpose assembly	2.5	0.3	120	-
Bathrooms/toilet-private ^g	-	-	-	12.5/25 ^f
Bedroom/living room	2.5	0.3	10	-
Conference/meeting	2.5	0.3	50	-
Dormitory sleeping areas	2.5	0.3	20	-
Gambling casinos	3.75	0.9	120	-
Lobbies/pre-function	3.75	0.3	30	-

Occupancy Classification	Outdoor Airflow Rate in Breathing Zone	Outdoor Airflow Rate in Breathing Zone^a	Default Occupant Density^a	Exhaust Airflow Rate^a
	<i>l/s per person</i>	<i>l/s per m²</i>	<i>No./100 m²</i>	<i>l/s per m²</i>
Offices				
Conference rooms	2.5	0.3	50	-
Office spaces	2.5	0.3	5	-
Reception areas	2.5	0.3	30	-
Telephone/data entry	2.5	0.3	60	-
Main entry lobbies	2.5	0.3	10	-
Private dwellings, single and multiple				
Garages, common for multiple units ^b	-	-	-	3.75
Garages, separate for each dwelling ^b	-	-	-	50 l/s per car
Kitchens ^b	-	-	-	12.5/50 ^f
Living areas ^c	0.35 Air Change per Hour (ACH) but not less than 7.5 l/s per person	-	Based upon number of bedrooms. First bedroom 2 persons; each additional bedroom 1 person	-
Toilet rooms and bath rooms ^g	-	-	-	10/25 ^f
Public spaces				
Corridors	-	0.3	-	-
Elevator car	-	-	-	5.0
Shower room (per shower head) ^g	-	-	-	25/10 ^f

Occupancy Classification	Outdoor Airflow Rate in Breathing Zone	Outdoor Airflow Rate in Breathing Zone^a	Default Occupant Density^a	Exhaust Airflow Rate^a
	<i>l/s per person</i>	<i>l/s per m²</i>	<i>No./100 m²</i>	<i>l/s per m²</i>
Smoking lounges	30	-	70	-
Toilet rooms - public ^g	-	-	-	25/30 ^e
Places of religious worship	2.5	0.3	120	-
Courtrooms	2.5	0.3	70	-
Legislative chambers	2.5	0.3	50	-
Libraries	2.5	0.6	10	-
Museums (children's)	3.75	0.6	40	-
Museums/galleries	3.75	0.3	40	-
Retail stores, sales floors and showroom floors				
Sales (except as below)	3.75	0.6	15	-
Dressing rooms	-	-	-	1.25
Mall common areas	3.75	0.3	40	-
Shipping and receiving	-	0.6	--	-
Smoking lounges ^b	30	-	70	-
Storage rooms	-	0.6	--	-
Warehouses (see storage)	-	-	-	-
Specialty shops				
Automotive motor-fuel dispensing stations ^b	-	-	-	7.5
Barber	3.75	0.3	25	2.5
Beauty and nail salons ^b	10	0.6	25	3.0
Embalming room ^b	-	-	-	10.0
Pet shops (animal areas) ^b	3.75	0.9	10	4.5
Supermarkets	3.75	0.3	8	-

Occupancy Classification	Outdoor Airflow Rate in Breathing Zone	Outdoor Airflow Rate in Breathing Zone^a	Default Occupant Density^a	Exhaust Airflow Rate^a
	<i>l/s per person</i>	<i>l/s per m²</i>	<i>No./100 m²</i>	<i>l/s per m²</i>
Sports and amusement				
Disco/dance floors	10	0.3	100	-
Bowling alleys (seating areas)	5	0.6	40	-
Game arcades	3.75	0.9	20	-
Ice arenas without combustion engines	-	0.30	-	2.5
Gym, stadium, arena (play area)	-	0.30	-	-
Spectator areas	3.75	0.3	150	-
Swimming pools (pool and deck area)	-	2.4	--	-
Health club/aerobics room	10	0.3	40	-
Health club/weight room	10	0.3	10	-
Storage				
Repair garages, enclosed parking garages ^{b,d}	-	-	-	3.75
Warehouses	-	0.3	-	-
Theaters				
Auditoriums (see education)	-	-	--	-
Lobbies	2.5	0.3	150	-
Stages, studios	5	0.3	70	-
Ticket booths	2.5	0.3	60	-
Transportation				
Platforms	3.75	0.3	100	-
Transportation waiting	3.75	0.3	100	-

Occupancy Classification	Outdoor Airflow Rate in Breathing Zone	Outdoor Airflow Rate in Breathing Zone^a	Default Occupant Density^a	Exhaust Airflow Rate^a
	<i>l/s per person</i>	<i>l/s per m²</i>	<i>No./100 m²</i>	<i>l/s per m²</i>
Workrooms				
Bank vaults/safe deposit	2.5	0.3	5	-
Darkrooms	-	-	-	5.0
Copy, printing rooms	2.5	0.3	4	2.5
Meat processing ^c	7.5	-	10	-
Pharmacy (prep. area)	2.5	0.9	10	-
Photo studios	2.5	0.6	10	-
Computer (without printing)	2.5	0.3	4	-

a Based upon net occupiable floor area.

b Mechanical exhaust required and the recirculation of air from such spaces is prohibited. All air supplied to such spaces shall be exhausted, including any air in excess of that required by this table.

c Spaces unheated or maintained below 50°F are not covered by these requirements unless the occupancy is continuous.

d Ventilation systems in enclosed parking garages shall comply with Sec 2.11.3.8.

e Rates are per water closet or urinal. The higher rate shall be provided where periods of heavy use are expected to occur, such as toilets in theaters, schools and sports facilities. The lower rate shall be permitted where periods of heavy use are not expected.

f Rates are per room unless otherwise indicated. The higher rate shall be provided where the exhaust system is designed to operate intermittently. The lower rate shall be permitted where the exhaust system is designed to operate continuously during normal hours of use.

g Mechanical exhaust is required and recirculation is prohibited except that recirculation shall be permitted where the resulting supply air-stream consists of not more than 10 percent air re-circulated from these spaces (see Sec 2.11.3.6, items a and c).

h For nail salons, the required exhaust shall include ventilation tables or other systems that capture the contaminants and odors at their source and are capable of exhausting a minimum of 25 l/s per station.

2.7.3.4 Noise control

- (a) Air Ducts: Air ducts shall be so designed and installed to avoid any transmission of noise and vibration which may be picked up by the duct system from equipment room or adjoining rooms. Duct system shall not allow cross talk or noise transfer from one occupied space to another.

Duct system shall be appropriately designed, constructed and installed to obtain adequate attenuation of noise required to maintain recommended noise level in the air-conditioned space.

Duct construction and installation shall be such that drumming effect of duct walls and noise transmission through the duct walls can be minimized to the approved level.

- (b) Plenum Chamber: If required, properly designed plenum chamber, lined with approved sound absorbed material, and/or sound attenuators shall be used for attenuation of noise.
- (c) Flow Control Devices: Air dampers and other flow control devices shall be so selected that noise generation does not exceed approved levels.
- (d) Air Terminals: Air terminals shall be selected for the approved noise generation characteristics.
- (e) Piping: Velocity of fluids in piping shall be so selected that noise generation does not exceed approved levels.
- (f) Chiller and Refrigeration Equipment: Chiller(s) and refrigeration equipment(s) shall be so selected and installed that the combined effect of noise level does not exceed 65 dBA or approved levels at the property boundary line. Where ever possible refrigerant compressors may be encased in acoustically treated enclosures to reduce noise transmission. Similarly, low speed condenser fans may be used to have reduced noise generation. Fan cylinders may be acoustically treated to reduce noise transmission.
- (g) Cooling Tower: Cooling Towers(s) shall be so selected and installed that the combined effect of noise generation does not exceed 65 dBA or approved levels at the proper boundary level. Where ever possible, fan cylinders shall be acoustically treated to reduce noise transmission. Floating mats may also be used to reduce water droplet noise.

2.7.3.5 Vibration control

- (a) Appropriately designed vibration isolators shall be installed under the machinery to restrict vibration transmission to structures. Similarly vibration isolators shall also be used between machinery and all pipe work and duct work including the supports when applicable.
- (b) Where ever necessary “Inertia Block” with spring vibration isolators shall be used to restrict vibration transmission to structures.
- (c) Spring vibration isolators shall be earthquake restraint type.

2.8 Air Distribution System

2.8.1 Duct Work

2.8.1.1 General

- (a) Supply air, return air and outside air for air-conditioning, heating and ventilation systems shall be conducted through duct systems. Ducts and plenums shall be of independent construction or shall be formed by parts of the building structure.
- (b) Supply and return air plenums shall be limited to uninhabited crawl spaces, areas above a ceiling or below the floor, or attic spaces. Plenums shall be limited to one fire area. Fuel-fired equipment shall not be installed within a plenum. Venting systems and exhaust ducts shall not be extended into or through ducts or plenums.
- (c) Prohibited Use: Exits and exit access corridors shall not be used as supply or return air ducts or plenums.

Exception: The restriction on the use of the space between the corridor ceiling and the floor or roof structure above as return air plenum shall not apply when the corridor is not required to be of fire resistance rated construction or is separated from the plenum by fire resistance rated construction or is located within a dwelling unit.

- (d) Flood Proofing: For building located in a flood hazard zone, plenum spaces shall be either placed above the base flood elevation or protected so as to prevent water from entering or accumulating within the plenum space during floods up to the base flood elevation.

2.8.1.2 Material

- (a) All ducts, duct connectors, associated fittings and plenums used to convey supply air, return air, and outdoor air for air-conditioning, heating and ventilation system shall be constructed of steel, aluminum alloy or some other approved metal. Ducts, plenums and fittings may be constructed of concrete, clay or ceramics when installed in the ground or in a concrete slab, provided the joints are tightly sealed.

- (b) When gypsum products are exposed in ducts or plenums, the air temperature shall neither be lower than 10°C nor be higher than 52°C and the moisture content shall be controlled so as not to adversely affect the material. Gypsum products shall not be exposed in ducts serving evaporative coolers.

2.8.1.3 Combustibles within ducts or plenums

Plenums shall be constructed with non-combustible materials. Materials exposed within ducts or plenums shall have a flame spread index of not more than 25, and smoke developed rating of not more than 50 when tested in accordance with ASTM E84.

Exceptions:

- (i) Return air and outside air ducts, plenums and concealed spaces which serve a dwelling unit may be of combustible construction.
- (ii) Air filters serving dwelling unit.
- (iii) Air filters used as water evaporation medium in an evaporative cooler.
- (iv) Charcoal filters when protected with an approved fire suppression system.
- (v) Exposed electric cables installed in concealed space used as plenums exhibit a flame propagation of not more than 1.5 m and produce smoke having a peak optical density not greater than 0.5 and average optical density not greater than 0.15 when tested in accordance with UL910.
- (vi) Nonmetallic fire sprinkler piping in the plenum exhibit a flame propagation of not more than 1.5 m and shall produce smoke having a peak optical density not greater than 0.5 and average optical density not greater than 0.15 when tested in accordance with UL1820.

2.8.1.4 Duct construction

- (a) Ducts shall be of square, rectangular, round or oval cross-section. Construction of required size of duct shall be as per good practice described in ASHRAE Handbooks and SMACNA (Sheet Metal and Air-conditioning Contractors' National Association, USA) duct construction standards.
- (b) Joints of duct systems shall be made substantially airtight by means of tapes, mastics, gasketing or other means and shall have no opening other than those required for proper operation and maintenance of the system. Access openings shall be provided in the duct system for periodic cleaning of the system. Removable grilles requiring only the loosening of catches or screws for removal may be considered as access openings. Walk in access doors shall be so constructed that the door may be readily opened from the inside without the use of keys.

- (c) Vibration isolators installed between equipment and metal ducts (or casings) or between two sections of the ducts where duct crosses building expansion joint, shall be made of an approved flame retardant fabric or shall consist of sleeve joints with packing of approved material having flame spread rating of not more than 25 and a smoke developed rating of not more than 50 when tested in accordance with ASTM E84. Vibration isolation connectors constructed of fabric shall not exceed 250 mm in length.

2.8.1.5 Duct coverings

- (a) Supply and return air ducts and plenums of a cooling or heating system shall be insulated with approved quality insulating material of adequate thickness required as per location of the duct system and temperatures of air inside and around the duct system. Insulation shall be of such quality and thickness to prevent the formation of condensation on the exterior or interior walls of any duct.
- (b) Materials used within the ducts and plenums for insulation, sound absorption or other purposes shall have a mold, humidity and erosion resistant face that meets the requirements of accepted standards. These materials when exposed to air velocities within the ducts in excess of 10 m/s shall be fastened with both adhesive and mechanical fasteners, and exposed edges shall have adequate treatment to withstand the operating velocity.
- (c) Duct coverings, duct linings, vapour barrier facings, tapes, adhesives used in duct system shall have a flame spread rating not over 25 and a smoke development rating no higher than 50 when tested as a composite installation:

Exceptions:

- (i) Duct coverings shall not be required to meet these requirements where they are located entirely outside of a building, do not penetrate a wall or roof, and do not create an exposure hazard.
- (ii) Duct covering having a flame spread index not exceeding 50 and a smoke density not greater than 100 may be used in dwelling/apartment houses where duct system serves not more than one dwelling unit.
- (d) Duct coverings, linings, including associated tapes and adhesives shall be interrupted at least 1 m from heat source in a duct system such as electric resistance heaters, fuel burning heaters or furnaces and at the area of a fire damper or fire door, where the duct penetrates a fire separation. Interior insulation and acoustical linings shall be placed so as not to interfere with positive closing of fire dampers or other closures.
- (e) Service openings shall not be concealed.

2.8.1.6 Duct installation

- (a) An air distribution system shall be designed and installed as per good practice described in ASHRAE Handbooks and SMACNA Handbook so as to meet the requirement of proper distribution of air as per provisions of this Code. The installation of an air distribution system shall not affect the fire protection requirements specified in this Code.
- (b) Ducts and all parts of the duct system shall be substantially supported and securely fastened to the structural members of the building with approved devices of noncombustible material designed to carry the required loads. Duct supports shall not lessen the fire protections of structural members. Ducts shall be braced and guyed to prevent lateral or horizontal swing.
- (c) Hangers shall have sufficient strength and durability to properly and safely support the duct work. Hangers shall have sufficient resistance to the corrosive effect of the atmosphere to which they will be exposed. Hangers shall not be used in direct contact with a dissimilar metal that would cause galvanic action in the hanger, duct, fastenings, or structure.
- (d) Ducts shall not be hung from or supported by suspended ceilings.
- (e) Metal ducts shall not usually be installed within 100 mm of the ground. Metal ducts not having an approved protective coating, when installed in or under concrete slab shall be encased in at least 50 mm of concrete. Metallic ducts having an approved protective coating and nonmetallic ducts shall be installed in accordance with the manufacturer's installation instructions.
- (f) When ducts penetrate any masonry wall, it shall either be lined with felt to isolate it from the masonry, or an air gap shall be left around it.
- (g) All underground ducts located in a flood hazard zone shall be capable of resisting hydrostatic and hydrodynamic loads and stresses, including the effects of buoyancy, during the occurrence of flooding to the base flood elevation.
- (h) Ducts installed in locations where they are subject to mechanical damage by vehicles or from other causes shall be protected by approved barriers.

2.8.1.7 Fire damper

- (a) Fire dampers shall be provided at locations where air distribution systems penetrate assemblies that are required to be fire resistance rated by this Code.

Exceptions:

- (i) Fire dampers are not required in the following cases:
 - (ii) Where an exhaust duct penetrates a fire resistance rated shaft wall and the sub-duct extends not less than 560 mm vertically upward.
 - (iii) At penetrations of tenant separation and corridor walls in buildings equipped throughout with an automatic sprinkler system installed in accordance with the Code.
 - (iv) Where the ducts are constructed of steel and are part of an engineered smoke removal system.
 - (v) At penetration of corridor walls where the ducts are constructed of steel and do not have openings which communicate the corridor with adjacent spaces or rooms.
 - (vi) At penetrations of a roof assembly where ducts are open to the atmosphere.
 - (vii) In hazardous exhaust systems.
 - (viii) Where ceiling dampers are installed in accordance with the building code.
 - (ix) In garage exhaust or supply shafts which are separated from all other building shafts by not less than 2-hour fire resistance rated fire separation assembly.
 - (x) In ducted air-conditioning, heating and ventilation systems penetrating walls with a 1 hour fire resistance rating or less. Where fire dampers will interfere with the operation of the smoke control system, approved alternative protective devices shall be utilized.
- (b) Fire dampers shall comply with UL555 and bear the label of an approved agency. Fire dampers shall be installed in accordance with the manufacturing installation instructions.
- (c) Fire dampers shall be accessible. Suitable openings with tightly fitted covers shall be provided to make fire dampers accessible for inspection and this shall be large enough to permit maintenance and resetting of the damper.
- (d) Ductwork shall be connected to fire damper sleeves or assemblies in such a way that collapse of the ductwork will not dislodge the damper.

2.8.1.8 Automatic shutoff

- (a) Each single air distribution system providing air-conditioning, heating or ventilation air in excess of 1000 l/s in various occupancies, shown below, shall be equipped with an automatic shutoff provision activated by smoke detectors. When the system serves more than one occupancy, automatic shutoff must be provided.

Type of Occupancy	Subdivision	Type of Occupancy	Subdivision
A	A5	G	G2
B	All (B1, B2 & B3)	H	H2
C	All (C1, C2, C3, C4 & C5)	I	I1, I2, & I3
D	All (D1 & D2)	J	All (J1, J2, J3 & J4)
E	E1 & E3	L	L
F	F1 & F2		

Exceptions:

- (i) Automatic shutoff need not be installed when all rooms have direct exit to the exterior of the building.
- (ii) Automatic shutoff need not be installed in systems specifically designed for smoke control.
- (b) Smoke Detection: Smoke detectors required by Sec 2.5.1.8 shall be installed in the main return-air duct ahead of any outside air inlet or they may be installed in each room or space served by the return air duct. Detectors shall also be installed in the supply duct, downstream of the filters. Activation of any detector shall cause the air moving equipment to automatically shut down.

2.8.2 Air Terminals

2.8.2.1 Registers, grilles and diffusers

Supply air registers, grilles and diffusers; and return air grills shall be installed in accordance with the manufacturer's installation instructions. Selection and installation of registers, grilles and diffusers shall comply with the requirements of air distribution system.

2.8.2.2 Ventilating ceilings

Perforated ceilings may be used for air supply except in exit corridors which are required to be of fire resistive construction. Ceiling material shall be of Class-I flame spread classification on both sides in accordance with requirements of this Code. All wiring shall be in enclosures regardless of the voltage carried. Suspended ventilating ceiling supports shall be of non-combustible materials.

2.8.2.3 Visual duct openings

Duct openings in bathrooms, toilets and changing rooms shall prevent visual observation from adjoining rooms.

2.8.2.4 Capped opening

All duct openings shall be capped during construction.

2.8.2.5 Return air intake and outside air intake

Return air and outside air intake openings shall be located in accordance with the requirements of Sec 2.6.2.7.

2.8.2.6 Exhaust openings

Outside exhaust openings shall be located so as not to create nuisance. Exhaust air shall not be directed onto walkways.

2.8.2.7 Opening protection

Outside air intake and exhaust openings shall be protected with corrosion-resistant screens, louvers or grilles. Openings shall be protected against all local weather conditions. Exhaust openings shall have provision to prevent back draft under wind conditions.

2.8.3 Exhaust Air Systems

2.8.3.1 General

- (a) Exhaust air systems serving kitchens or toilets and/or bathrooms shall be independent exhaust systems and shall not be combined with exhaust air ducts serving other areas, except at immediately before the point of final delivery to the outside, such as at the base of a roof ventilator or when all interconnected systems are equipped with suitable back pressure devices to prevent passage of odours from one system to another when the fan is not in operation.
- (b) Exhaust ducts shall have provision for removal of condensates where this may be a problem, such as for swimming pools and shower exhausts and for these applications duct joints shall be water tight.
- (c) Construction and installation of exhaust air ducts for toilet, bathrooms and swimming pools shall be in accordance with the provisions of Sec 2.5.1.
- (d) Design, construction and installation of exhaust air systems for exhaust of harmful and hazardous gases and industrial/process exhaust gases shall be in accordance with the provisions of Sec 2.8.4.
- (e) Design, construction and installation of kitchen exhaust system shall be in accordance with the provisions of Sec 2.8.5.

2.9 Air-Conditioning Equipment

2.9.1 General

2.9.1.1 Scope

Air-conditioning, heating and ventilation equipment shall conform to the requirements of this Code.

Equipment shall not be installed or altered in violation of this Code. Defective materials or parts shall be replaced in such a manner as not to invalidate any approval.

2.9.1.2 Approval

When required each appliance shall be approved by the building official for safe use or comply with applicable nationally recognized standard. For this purpose installers shall furnish satisfactory evidence that the appliance is constructed in conformity with the requirements of this Code. The permanently attached label of an approved agency may be accepted as such evidence.

2.9.1.3 Labeling

All mechanical equipment and appliances shall bear permanent and legible factory applied name plate on which shall appear construction and operation data including safety requirements.

2.9.1.4 Testing

Where required an approved agency shall test a representative sample of the mechanical equipment or appliance being labeled to the standard or standards pertinent to the equipment or appliance. The approved agency shall maintain a record of all tests performed. The records shall provide sufficient detail to verify compliance with the test standard.

2.9.1.5 Equipment installation

- (a) General: Mechanical equipment and appliances shall be installed in accordance with the manufacturer's installation instructions for the labeled equipment. Connections to mechanical equipment or appliances, such as fuel supply, electrical, hydronic piping, vent and ducts shall conform to the requirements of this Code.
- (b) Clearance: Appliances shall be installed with the minimum clearances to combustibles for which the appliance has been tested as specified by the manufacturer.
- (c) Anchorage of Appliances: Appliances designed to be fixed in position shall be securely fastened in position. Supports for appliances shall be designed and constructed to sustain vertical and horizontal loads within the stress limitations specified in the Code.

- (d) Noise and Vibration: Equipment noise and vibration transmitted to the occupied space shall not exceed the recommended value for the space. Selection and installation of equipment shall be in accordance with Sec 2.4.3.
- (e) Identification of Equipment: When more than one air-conditioning, heating, refrigerating or ventilation systems are installed on the roof of a building or within the building, each equipment shall be identified as to the area or space served by the equipment.

2.9.1.6 Access

All mechanical equipment and appliances shall be accessible for inspection, service, repair and replacement without removing permanent construction. Unless otherwise specified not less than 750 mm of working space and platform shall be provided to service the equipment or appliance.

Appliance controls, gauges, filters, blowers, motors and burners shall be accessible. The operating instructions shall be clearly displayed near the appliance where they can be read easily.

2.9.1.7 Location

- (a) Remote Location: Where an appliance is located in a remote location, a walkway having a minimum width of 600 mm shall be provided, leading from the access opening to the appliance.
- (b) Hazardous Location: Appliances installed in garages, warehouses, or other areas where they may be subject to mechanical damage shall be installed behind suitable protective barriers or at a suitable height above the floor or located out of the normal path of vehicles to guard against such damages.

Air-conditioning or heating equipment located in a garage and which generates a glow, spark or flame capable of igniting flammable vapours shall be installed in such a way that the pilots and burners or heating elements and switches are at least 450 mm above the floor level.

Where such appliances installed within a garage are enclosed in a separate approved compartment having access only from outside of the garage such appliances may be installed at floor level, provided the required combustion air is taken from and discharged to the exterior of the garage.

Heating equipment located in rooms where cellulose nitrate plastic or other explosive materials are stored or processed shall comply with the requirements of Part 4 of this Code.

- (c) Outdoor Installation: Mechanical equipment and appliance located outdoors shall be approved for outdoor installation. Mechanical equipment and appliances installed outdoors shall conform to the requirements of Sec 2.6.1.5.

Where appliances are located within 3 m of a roof edge or open side of a drop greater than 600 mm, guards shall be provided. Height of the guard shall be a minimum of 900 mm and a maximum of 1050 mm above the surface.

Equipment that are located outdoors and may be adversely affected by sun and/or water shall be adequately protected. Access shall be possible under all weather conditions. All outdoor installed equipment shall be so located that the sound level shall not be more than 65 dB when measured anywhere on the property boundary line.

2.9.1.8 Electrical installations

- (a) Equipment regulated by this Code requiring electrical connections of more than 50 volts shall have a positive means of disconnect adjacent to and in sight from the equipment served. A 230 volt AC grounding type receptacle shall be located within 8 m of the equipment for service and maintenance purposes. The receptacle need not be located on the same level as the equipment. Low voltage wiring of 50 volts or less within a structure shall be installed in a manner to prevent physical damage.
- (b) Permanent lighting shall be provided to illuminate the area in which an appliance is located. For remote locations, the light switch shall be located near the access opening leading to the appliance.

Exceptions:

Lighting fixtures need not be installed when the fixed lighting for the building will provide sufficient light for safe servicing of the equipment.

2.9.1.9 Condensate wastes

Condensates from air cooling coils, fuel burning condensing appliances and the overflow from evaporative coolers and similar water supplied equipment shall be collected and discharged to an approved plumbing fixture and disposal area. The waste pipe shall have a slope of not less than 1 in 100 and shall be of approved corrosion resistant material and approved size. Condensate or waste water shall not drain over a public way.

2.9.1.10 Personnel Protection

A suitable and substantial metal guard shall be provided around exposed flywheels, fans, pulleys, belts and moving machinery which are portions of air-conditioning, heating and ventilation system.

2.9.2 Cooling by Refrigeration**2.9.2.1 General**

- (a) Scope: Every air cooling system and equipment using refrigerant coils, chilled water coils and brine coils shall conform to the requirements of this Section and to the applicable requirements of Sections 2.6.1 and 2.7.
- (b) Use of Group 2 Refrigerants: Direct refrigerant systems containing Group 2 refrigerants shall not serve an air-cooling or air-conditioning system used for human comfort.

2.9.2.2 Installation

- (a) Clearance from Ground: When cooling equipment other than ducts and piping is suspended from the under floor construction, a clearance of at least 150 mm shall be provided between the base of the equipment and the ground.
- (b) Exterior Wall Installation: All equipment mounted on exterior wall at a height of 6 m or more above the ground shall be provided on a platform not less than 750 mm in depth, with 1 m high handrails on operation and control side of the equipment. The platform shall be accessible through catwalk not less than 450 mm wide and handrail of 1 m high from inside the building or from roof access.

Exceptions:

Equipment located on exterior wall but removable from inside may not require platform and catwalk.

2.9.2.3 Access

- (a) Cooling Units: Except for piping, ducts and similar equipment that does not require servicing or adjusting, an unobstructed access and passageway not less than 600 mm in width and 2 m in height shall be provided to every cooling unit installed inside buildings.

Exception:

The access opening to a cooling unit located in an attic space may be reduced to 750 mm in length and width, provided the unit can be replaced from this opening or another opening into this space or area.

- (b) Attic or Furred Space Installation: Access to and working platforms for cooling units or cooling system compressors located in an attic or furred space shall be provided with a solid continuous flooring not less than 600 mm in width from the access opening to the required working space and platform in front of the equipment when access opening is located more than 1 m away from working space.

- (c) Filters, Fuel Valves and Air Handlers: An unobstructed access space not less than 600 mm in width and 750 mm in height shall be provided to filters, fuel control valves and air handling units. Refrigerant, chilled water and brine piping control valves shall be accessible.

Exception:

An access opening from the unobstructed access space which opens directly to such equipment may be reduced to 375 mm in the least dimension if the equipment can be serviced, repaired and replaced from this opening without removing permanent construction.

- (d) Refrigeration Machinery Room Installations: Access to equipment located in a refrigeration machinery room shall comply with Sec 2.7.

- (e) Roof or Exterior Wall Installation

(i) Equipment installed on the roof or on an exterior wall shall be accessible under all weather conditions. A portable ladder or other portable temporary means may be used for access to equipment located on the roof, or on exterior wall of a single-storey portion of the building.

(ii) Platform: When the roof has a slope greater than 4 in 12 a level working platform at least 750 mm in depth shall be provided along the control or servicing sides of the unit. Sides of a working platform facing the roof edge below shall be protected by a substantial railing of minimum 1 m in height with vertical rails not more than 525 mm apart, except that parapets at least 600 mm in height may be utilized in lieu of rails or guards.

(iii) Catwalk: On roofs having slopes greater than 4 in 12, a catwalk at least 400 mm in width with substantial cleats spaced not more than 400 mm apart shall be provided from the roof access to the working platform at the appliance.

2.9.2.4 Working space

Equipment requiring access thereto, as specified in Sec 2.6.2.3, shall be provided with an unobstructed space on the control or servicing side of the equipment of not less than 750 mm in depth and 2 m in height. Working space for equipment located in a machinery room shall comply with Sec 2.7.

Exception:

The height of the working space may be reduced to 750 mm for an air handling unit, air filter or refrigerant, chilled water piping and brine piping control valves.

2.9.2.5 Lighting in concealed spaces

When access is required to equipment located in an under floor space, attic or furred space, a permanent electric light outlet and lighting fixture shall be installed in accordance with Sec 2.6.1.8.

2.9.2.6 Condensate control

When a cooling coil or cooling unit is located in the attic or furred space where damage may result from condensate overflow, an additional water tight pan of corrosion resistant metal shall be installed beneath the cooling coil or unit to catch the overflow condensate due to clogged primary condensate drain, or one pan with a standing overflow and a separate secondary drain may be provided in lieu of the secondary drain pan. The additional pan or the standing overflow shall be provided with a drain pipe, minimum 19 mm nominal pipe size, discharging at a point which can be readily observed. This requirement is in addition to the requirements for condensate waste piping set forth in Sec 2.6.1.9.

2.9.2.7 Return air and outside air

- (a) Source: A cooling unit shall be provided with outside air, return air, or both. Cooling systems regulated by this Code and designed to replace required ventilation shall be arranged to deliver into the conditioned space not less than the amount of outside air specified in Building Code.
- (b) Prohibited Sources: The outside air or return air for a cooling system or cooling unit shall not be taken from the following locations:
 - (i) Closer than 3 m from an appliance vent outlet, a vent opening or a plumbing drainage system or the discharge outlet of an exhaust fan, unless the outlet is 1 m above the outside air inlet.
 - (ii) Where it will pick up objectionable odours, fumes or flammable vapours; or where it is less than 3 m above the surface of any abutting public way or driveway; or where it is in a horizontal position in a sidewalk, street, alley or driveway.
 - (iii) A hazardous or insanitary location or a refrigeration machinery room;
 - (iv) An area the volume of which is less than 25 percent of the entire volume served by such system, unless there is a permanent opening to an area the volume of which is equal to 25 percent of the entire volume served.
 - (v) A room or space having any fuel burning appliances therein, except when 75 percent of the conditioned air is discharged back into the same room or space and air inlets are not located within 3 m of firebox or draft diverter of fuel burning appliance and the room has a volume exceeding 1 m³ for each 100 watts fuel input rate of all fuel burning appliance therein.
 - (vi) A closet, bathroom, toilet or kitchen.

- (c) Return Air Limitation: Return air from one dwelling unit shall not be discharged into another dwelling unit through the cooling system.

2.9.2.8 Air velocity

Cooling systems shall be designed and constructed so that velocity through filters does not exceed the filter manufacturer's recommendation.

2.9.2.9 Screen

Required outside air inlets shall be covered with screen having 6 mm openings.

Exception:

An outside air inlet serving a nonresidential portion of a building may be covered with screen having opening larger than 6 mm but not larger than 25 mm.

2.9.2.10 Duct system

If ducts are required for circulation of air, the duct system shall be constructed and installed in accordance with Sec 2.5.1. Selection and installation of registers, diffusers and grilles shall conform to the requirements of Sec 2.5.2.

2.9.3 Evaporative Cooling

2.9.3.1 General

- (a) Scope: Where possible evaporative cooling system may be installed. Evaporative cooling systems shall comply with this Section.
- (b) Outside Air: Evaporative cooling system shall be provided with outside air as specified in Sec 2.6.2.7
- (c) Air Ducts: Air duct systems for evaporative cooling shall comply with Sec 2.5.1.

2.9.3.2 Location

Evaporative cooler shall normally be installed outdoor. It may be installed indoor if duct is provided between cooler and outside air intake.

Evaporative cooling systems shall be installed in a manner to minimize the probability of damage from an external source.

2.9.3.3 Access

Evaporative coolers shall be accessible for inspection, service and replacement without removing permanent construction.

2.9.3.4 Installation

An evaporative cooler supported by the building structure shall be installed on a substantial level base and shall be secured directly or indirectly to the building structure by suitable means to prevent displacement of the cooler.

An evaporative cooler supported directly by the ground shall rest on a level concrete slab. The upper surface of the concrete slab shall not be less than 75 mm above the adjoining ground level.

An evaporative cooler supported on an above ground platform shall be elevated at least 150 mm above the adjoining ground level.

Openings in the exterior walls shall be flushed in an approved manner in accordance with this Code.

2.9.4 Heating Equipment

2.9.4.1 General

- (a) Scope: Provisions of this Section shall apply to all electric, hot water or steam air heating systems.
- (b) Outside Air: Heating system shall be provided with outside air as specified in Sec 2.6.2.7.
- (c) Air Ducts: Air ducts for heating systems shall comply with the applicable provisions of Sec 2.5.1.

2.9.4.2 Location

- (a) Steam shall not be used in heating coil of air handling unit when it is located inside the building but not installed in a machinery room.
- (b) All fuel burning equipment such as boilers shall not be installed inside a building and shall be installed inside a machinery room.
- (c) Appliances generating a glow, spark or flame capable of igniting flammable vapours shall not be located in places where such vapours exist.

2.9.4.3 Access

All appliances shall be accessible for inspection, services, repair and replacement without removing permanent construction. On control and servicing side(s) of the appliance, an unobstructed working space of not less than 750 mm in width and 1250 mm in height shall be provided.

2.9.4.4 Installation

All heating appliances shall be installed as per applicable provisions of Sec 2.6.1.5.

2.9.4.5 Controls

- (a) In case of air-conditioning plants where heating or reheating is required, a safety device shall be incorporated in the installation to cut off automatically the source of heating, such as steam, hot water or electricity by means of a suitable thermostat or some other device, as soon as the temperature of the room reaches a predetermined high level not exceeding 44°C, unless a higher temperature is required for an industrial process carried out in the air-conditioned enclosure. In no case the outlet temperature of the heater shall exceed 90°C.
- (b) In the case of air-conditioning plants where heating or reheating by means of an electrical heater designed to operate in an air current is done, the system shall be equipped with a safety device to cut off the electricity to the heating device whenever there is failure of the air flow in which the heater is required to operate.

The surface temperature of all electrical heaters used in air-conditioning systems shall be limited preferably to 400°C, and in no case more than 538°C when measured in still air.

2.9.4.6 Boilers and Furnaces

- (a) Steam and hot water boilers and furnaces used for air-conditioning systems shall be designed, constructed and installed in conformance with the requirements of acceptable standards in this regard and the appropriate Boiler Code.
- (b) Boilers and furnaces shall be installed in a machinery room having:
 - (i) A sufficiently large floor area to permit accessibility for inspection and servicing of the appliance and to provide adequate clearance to satisfy requirements of fire safety. The volume of the room for housing central heating furnaces shall be at least 12 times the total volume of the furnace. The volume of the room for housing central heating boilers shall be at least 16 times the total volume of the boiler. If the ceiling height of the room or space is greater than 2.5 m, the volume shall be calculated on the basis of 2.5 m height.
 - (ii) A permanent opening or opening connecting with the outdoors or with some space that freely connects with outdoors,
 - (iii) A knockout panel to act as explosion relief panel to prevent damage to structure in case of any explosion in boiler rooms,
 - (iv) Boiler rooms and furnace rooms shall be protected with an automatic fire suppression system installed in accordance with the Code.
- (c) Before commissioning of the boiler a certificate of compliance from the Chief Inspector of Boiler shall be obtained.

2.9.5 Air Handling Unit**2.9.5.1 General**

Air handling units shall comply with the applicable requirements as set forth in Sections 2.6.1 and 2.6.2.

2.9.5.2 Location

Air handling unit rooms shall, as far as possible, be centrally located with the equipment room contiguous to the corridors or other spaces for running of air ducts.

Air handling unit rooms shall be located in areas where reasonable sound levels can be tolerated. Air handling unit rooms shall not preferably be located adjacent to conference rooms, sound recording studios, broadcasting studios, bed rooms and other acoustically sensitive areas. If it is absolutely necessary to locate air handling unit room adjacent to the above acoustically sensitive areas, adequate acoustic treatment in the air handling units, supply and return air ducts, air handling unit rooms shall be provided. In such case, the access door to the air handling unit room shall be of single leaf type properly acoustically treated and shall have a door sill. The door shall open outwards.

In case of multi-storied buildings and for large capacity plant, independent air handling unit room(s) shall be provided for each floor when design calls for the same. The area served by each air handling unit shall conform to the fire protection measures adopted.

2.9.5.3 Access

Floor area of the air handling unit room shall be sufficient to allow proper layout of equipment with adequate access space and working space for proper operation and maintenance.

2.9.5.4 Installation

Air handling units shall be installed on vibration isolators to restrict transmission of vibration to the building structure. The base of the air handling unit shall be minimum 75 mm above the adjoining floor level. All air handling unit rooms shall have properly installed floor drains.

2.9.6 Packaged Air-conditioners**2.9.6.1 General**

Packaged air-conditioners shall comply with the applicable requirements set forth in Sections 2.6.1 and 2.6.2.

2.9.6.2 Prohibited use

Packaged air-conditioners shall not be used for,

- (a) Operation theatres where provisions for high percentage of fresh air and high quality filtration of air are required.
- (b) Special applications like sterile rooms for hospitals and clean rooms where high efficiency filtration is required.
- (c) Sound recording studios and other areas where criteria for acoustics are stringent.

Exceptions:

Single package units when installed far away from the air-conditioned space and are provided with properly designed sound attenuators that maintains the desired sound level inside the conditioned space.

- (d) Area requiring close and independent control of temperature and relative humidity.

Exception: Computer room air-conditioning.

- (e) Internal zones where no exposed wall is available for installation of room air-conditioners or no external platform is available for installation of outdoor installed unit.
- (f) The width of the area is such that throw of air from the air-conditioner cannot cover the required area.

2.9.6.3 Installation

- (a) Wall punches for room air-conditioners shall have proper sealing and resilient pad around the body of the unit to avoid leakage of air and vibration transmission.
- (b) Outdoor units shall be installed keeping adequate space for condenser air flow. The discharge of condenser air shall not create any disturbance to the adjacent rooms or buildings.
- (c) Refrigerant pipes and condensate drain pipes shall be properly installed and shall have proper insulation to avoid condensation on pipes. Indoor installations shall comply with the requirements of Sec 2.9.2.6.

2.9.7 Accessory Equipment

2.9.7.1 Air curtain

- (a) Where Required: In super markets, departmental stores, commercial buildings and other applications where the continuous movement of people and/or equipment through the door requires that the door be remained open continuously, adequately sized air curtains may be used to restrict entry of unconditioned air to conditioned space.

- (b) Installation: Air curtains shall be installed in such a way as to cover the whole width of the door. The width and velocity of air jet shall be sufficient to restrict the entry of unconditioned air to the conditioned space. The unit shall have provisions to control the jet velocity with respect to pressure and velocity of air in the unconditioned space.

2.9.7.2 Air filters

- (a) Air supplied to any space for cooling, heating or ventilation shall be adequately filtered before its point of discharge into the space. Minimum filtration efficiency shall be in accordance with good engineering practice for the space served, as recommended in ASHRAE Handbook.
- (b) Access: Adequate access to facilitate servicing of filters shall be provided. Doors, ladders, electric lighting etc. shall be provided where necessary. A device for indicating differential pressure across the filter bank shall preferably be fitted to determine the need for filter change.
- (c) Electrostatic Filters: Electrostatic filters when used shall be electrically interlocked so that power supply is disconnected when access door is opened.

2.9.8 Piping System

2.9.8.1 Material

Piping material for air-conditioning, heating and ventilation system shall be metallic only.

Exception: Condensate drain and waste water drain piping for cooling units may be nonmetallic.

2.9.8.2 Support and anchors

Adequately designed piping supports shall be used at approved space intervals to prevent undue stress on the pipe and building structure. Piping shall also be adequately anchored. Pipes shall not be supported or hanged from another pipe.

2.9.8.3 Expansion and contraction

Piping shall be installed with provisions to take care of expansion and contraction of the piping because of temperature changes of the fluid it conveys.

2.9.8.4 Pipe covering

- (a) All pipes likely to achieve a surface temperature during normal operation exceeding 70°C and are exposed to human contact or surface temperature lower than the dew point temperature of the surrounding air, shall be insulated with approved material suitable for the operating temperature of the system. The insulating material and its thickness shall be as recommended in ASHRAE Handbook.

- (b) Insulation and covering on pipes in which the temperature of the fluid exceeds 120°C:
- (i) Shall be of noncombustible material.
 - (ii) Shall not produce flame and smoke, glow or smoulder when tested in accordance with the latest standard in this regard at the maximum temperature to which such insulation or covering is to be exposed in service.

Combustible insulation and covering shall have a flame spread rating throughout the material, not exceeding 25 units in buildings of noncombustible construction, when pipes run in a horizontal or vertical service space. When pipes run in a room or space other than service space, the pipe covering shall have a flame spread rating not exceeding that required for the interior finish of the ceiling of the room or space.

Exception:

Pipe coverings may have a flame spread rating more than 25 and smoke developed index more than 100 when pipes are enclosed within walls, floor slabs or non-combustible raceways or conduits.

2.9.8.5 Steam or hot water bare pipes passing through a storage space shall be protected to prevent direct contact between the surface of pipe and the material stored.

Bare pipes containing steam or fluid at temperature above 120°C and passing through a combustible floor, ceiling or wall shall have a sleeve of metal at least 50 mm larger in diameter than pipe, packed with noncombustible material.

Minimum clearance between bare pipe and combustible materials shall not be less than 15 mm when temperature of steam or water in the pipe does not exceed 120°C and shall not be less than 25 mm for temperatures exceeding 120°C.

2.9.8.6 All piping shall be marked with approved markings for type of fluid carrying with direction of flow.

2.9.9 Split Air-Conditioners

2.9.9.1 General

Split air-conditioners shall comply with the applicable requirements set forth in Sections 2.6.1 and 2.6.2.

2.9.9.2 Prohibited Use

Split air-conditioners shall not be used for,

- (a) Operation theatres where provisions for high percentage of fresh air and high quality filtration of air are required.
- (b) Special applications like sterile rooms for hospitals and clean rooms where high efficiency filtration is required.
- (c) Sound recording studios and other areas where criteria for acoustics are stringent.

Exceptions:

Split air conditioners when installed far away from the air-conditioned space and are provided with properly designed sound attenuators which can maintain the desired sound level inside the conditioned space.

- (d) Area requiring close and independent control of temperature and relative humidity.

Exception: Computer room air-conditioning.

- (e) Internal zones where no exposed wall is available for installation of room air-conditioners or no external platform is available for installation of outdoor installed unit.
- (f) The width of the area is such that throw of air from the air-conditioner cannot cover the required area.

2.9.9.3 Installation

- (a) Wall punches for room air-conditioners shall have proper sealing and resilient pad around the body of the unit to avoid leakage of air and vibration transmission.
- (b) Outdoor units shall be installed keeping adequate space for condenser air flow. The discharge of condenser air shall not create any disturbance to the adjacent rooms or buildings.
- (c) Refrigerant pipes and condensate drain pipes shall be properly installed and shall have proper insulation to avoid condensation on pipes. Indoor installations shall comply with the requirements of Sec 2.9.2.6.

2.9.10 Variable Refrigerant Flow (VRF) System

2.9.10.1 General

Variable refrigerant flow (VRF) air-conditioning system shall comply with the applicable requirements set forth in Sections 2.6.1 and 2.6.2.

2.9.10.2 Prohibited Use

VRF system shall not be used for,

- (a) Operation theatres where provisions for high percentage of fresh air and high quality filtration of air are required.
- (b) Special applications like sterile rooms for hospitals and clean rooms where high efficiency filtration is required.
- (c) Sound recording studios and other areas where criteria for acoustics are stringent.

Exceptions:

VRF system when installed far away from the air-conditioned space and are provided with properly designed sound attenuators that maintains the desired sound level inside the conditioned space.

- (d) Area requiring close and independent control of temperature and relative humidity.

2.9.10.3 Installation

- (a) Wall punches for room air-conditioners shall have proper sealing and resilient pad around the body of the unit to avoid leakage of air and vibration transmission.
- (b) Outdoor units shall be installed keeping adequate space for condenser air flow. The discharge of condenser air shall not create any disturbance to the adjacent rooms or buildings.
- (c) Refrigerant pipes and condensate drain pipes shall be properly installed and shall have proper insulation to avoid condensation on pipes. Indoor installations shall comply with the requirements of Sec 2.9.2.6.

2.10 Refrigerating Equipment

2.10.1 General

2.10.1.1 Scope

In addition to other provisions of this Code, refrigerating systems and equipment shall conform to the requirements of this Section.

2.10.1.2 Approval

All refrigerating equipment and components shall comply with relevant internationally recognized Standards. The listing and label, attached to the equipment, of an approved agency may be accepted as evidence of compliance with applicable internationally recognized Standards.

2.10.1.3 Installation

Refrigerating equipment shall be installed to conform to the provisions of Sec 2.6.1 and the manufacturer's installation instructions.

2.10.1.4 Access

Access for refrigerating units shall be provided as for cooling units and cooling systems set forth in Sections 2.6.1.6 and 2.6.2.3.

2.10.1.5 Working space and working platform

Working space and working platform shall be provided as for cooling units and cooling systems set forth in Sec 2.6.2.4.

2.10.1.6 Prohibited location

Refrigerating systems and portion thereof shall not be located in an elevator shaft, dumb waiter shaft or a shaft having moving objects therein, or in a location where it will be subject to mechanical damage.

2.10.1.7 Condensate control

Piping and fittings which convey refrigerant, brine, chilled water or coolant, which generally reach a surface temperature below the dew point of the surrounding air and which are located in spaces or areas where condensation could cause a hazard to the building occupants, structure, electrical or other equipment shall be insulated to prevent such damage.

2.10.2 Absorption Refrigerating Equipment

2.10.2.1 Location

Fuel burning absorption systems shall not be installed in the following locations:

- (a) In any room or space less than 300 mm wider than the units installed therein, with a minimum clear working space of not less than 75 mm along the sides, back and top of the unit.
- (b) In a hazardous location.
- (c) In a surgical operating room or medical treatment room.
- (d) In any occupancy group unless separated from the rest of the building by not less than a one hour fire resistive occupancy separation.

Exceptions:

A separation shall not be required for equipment serving only one dwelling unit.

- (e) In a room used or designed to be used as a bedroom, bathroom, closet or in any enclosed space with access only through such room or space.
- (f) In a room from where noise and vibration may be transmitted to acoustically sensitive areas.

Absorption systems containing Group 2 refrigerants shall not be located in any building unless installed within a refrigeration machinery room provided as per Sec 2.7.3.3.

Absorption systems containing more than 9 kg of a Group 2 refrigerant shall be located not less than 6 m from any door, window or ventilating air inlet to a building.

2.10.2.2 Installation

Fuel burning absorption systems located outside of a building shall be completely enclosed in a weather proof housing of approved materials, unless approved for outdoor installation. The housing shall not be larger than necessary to properly cover and provide a minimum 150 mm clearance around the unit or units enclosed therein, including all controls and draft diverters.

An absorption system supported from the ground shall rest on a concrete slab. The upper surface of the concrete slab shall be at least 75 mm above the adjoining ground level.

2.10.2.3 Pressure relief devices

An absorption system shall be equipped with a factory installed pressure relief device, either a fusible plug, a rupture member or a pressure relief valve.

2.10.2.4 Combustion air

A fuel burning absorption system shall be provided with adequate combustion air including venting appliances.

2.10.2.5 Steam or hot water absorption system

All absorption systems using steam or hot water as energy source shall be installed in a machinery room unless the manufacturer has certified it suitable for outdoor installation. The machinery room shall comply with the provisions of Sec 2.7.3.3.

2.10.3 Mechanical Refrigerating Equipment

2.10.3.1 General

- (a) Scope: Mechanical refrigerating equipment shall comply with the provisions of Sec 2.7.1.

Refrigerating systems and equipment, including the replacement of parts and alteration, shall comply with the provisions of this Section.

- (b) Supports: Supports for compressors, condensing units and chillers shall be designed to safely carry the equipment. Supports from buildings or parts of buildings that are of noncombustible construction shall be noncombustible.

A compressor or portion of condensing unit supported from the ground shall rest on a concrete or other approved base. The upper surface of the concrete base shall be at least 75 mm above the adjoining ground level.

- (c) Ventilation of Rooms Containing Condensing Units: Rooms or spaces other than a refrigeration machinery room complying with the requirements of this Section, in which any refrigerant containing portion of a condensing unit is located, shall be provided with one of the following means of ventilation:
- (i) Permanent gravity ventilation openings of not less than 0.2 m² net free area opening directly to the outside of the building or extending to the outside of the building by continuous ducts,
 - (ii) A mechanical exhaust system arranged to provide at least 3 complete air change per hour and to discharge to the outside of the building.

Exception:

Mechanical exhaust system shall not be required if the room or space has a volume exceeding 40 m³ per kW of the unit or where such room or space has permanent gravity ventilation openings of 0.2 m² minimum total area to the other rooms or spaces exceeding 40 m³ per kW.

- (d) Compressor Near Exits: Refrigerant compressors of more than 4 kW rating shall be located at least 3 m from an exit unless separated by a one hour fire resistive occupancy separation.

2.10.3.2 Refrigerants

- (a) Classification: Refrigerants listed in Tables 8.2.4 and 8.2.5 or other refrigerants equivalent in safety to life, limb, health or property shall only be used in refrigerating equipment.

Note: Bangladesh is a signatory to the Montreal Protocol which proclaims phasing out of the use of some refrigerants viewed as responsible for depletion of the ozone layer and/or causing global warming. If at the time of using this Code, any of the refrigerants mentioned in Tables 8.2.4 and 8.2.5 is prohibited from use by the Government, the relevant row or rows of these two tables shall be deemed to be deleted. Likewise, if any safer substitutes to these refrigerants are available and permitted by the Government, these shall be included in the list of refrigerants permitted by this Code. In general, preference shall be given to equipment using refrigerants having relatively lower Ozone Depletion Potential and Global Warming Potential.

Table 8.2.4: Group-I Refrigerant Classification, Amount and Occupational Exposure Limit (OEL)

Refrigerant Designation	Name	Refrigerant Classification ^f	Degrees of Hazard ^a	Max. Quantity in Space Intended for Human Occupancy (g/m ³)	OEL ^e
R-11 ^d	Trichlorofluoromethane	A1	2-0-0 ^b	6.2	1,000
R-12 ^d	Dichlorodifluoromethane	A1	2-0-0 ^b	90	1,000
R-13 ^d	Chlorotrifluoromethane	A1	2-0-0 ^b	-	1,000
R-13B1 ^d	Bromotrifluoromethane	A1	2-0-0 ^b	-	1,000
R-14	Tetrafluoromethane	A1	2-0-0 ^b	400	1,000
R-22	Chlorodifluoromethane	A1	2-0-0 ^b	210	1,000
R-32	Difluoromethane (Methylene chloride)	A2	-	77	1,000
R-113	Trichlorotrifluoroethane	A1	2-0-0 ^b	20	1,000
R-114	Dichlorotetrafluoroethane	A1	2-0-0 ^b	140	1,000
R-115	Chloropentafluoroethane	A1	2-0-0 ^b	760	1,000
R-123	Dichlorotrifluoroethane	B1	2-0-0 ^b	57	1,000
R-134a	Tetrafluoroethane	A1	2-0-0 ^b	210	1,000
R-407C	R-32/125/134a	A1	2-0-0 ^b	270	1,000
R-500	R-12/152a	A1	2-0-0 ^b	120	1,000
R-502	R-22/115	A1	2-0-0 ^b	330	1,000
R-717	Ammonia	B2	3-3-0 ^c	0.22	25
R-744	Carbon dioxide	A1	2-0-0 ^b	72	5,000

Notes :

- a* Degrees of hazard are for health, fire, and reactivity, in accordance with NFPA 704.
- b* Reduction to 1-0-0 is allowed if analysis satisfactory to the code official shows that the maximum concentration for a rupture or full loss of refrigerant charge would not exceed the IDLH, considering both the refrigerant quantity and room volume.
- c* For installations that are entirely outdoors, use 3-1-0.

- d* Class 1 ozone depleting substance; prohibited for new installations.
- e* Occupational Exposure Limit based on OSHA PEL.
- f* The capital letter designates the toxicity of the refrigerant at 400 ppm by volume. The number denotes the flammability of the refrigerant.
- Class A: Toxicity not identified
- Class B: Evidence of toxicity identified.
- Class 1: No flame propagation in air at 65°F and 14.7 psia.
- Class 2: Lower flammability limit (LML) greater than 0.00625 lb/ft³ at 70°F and 14.7 psia and heat of combustion less than 8174 Btu/lb.
- Class 3: Highly flammable as defined by LFL less than or equal to 0.00625 lb/ft³ at 70°F and 14.7 psia or heat of combustion greater than or equal to 8174 Btu/lb.

Table 8.2.5: Group 2 Refrigerants

Refrigerant Designation	Name
R-40	Methyl chloride
R-611	Methyl format
R-717	Ammonia
R-764	Sulphur dioxide

(b) Group 1 Refrigerants

- (i) Direct Systems: The maximum amount of Group 1 refrigerants in direct systems shall not exceed that set forth in Table 8.2.4.
- (ii) Indirect Systems: The amount of Group 1 refrigerants used in indirect systems shall be unlimited.
- (iii) General: Condensing units or combinations of refrigerant interconnected condensing units totaling 75 kW or more rating which contain a Group 1 refrigerant shall be enclosed in a refrigeration machinery room.

Exception:

The requirement shall not apply when the condensing unit is located outside of a building or on the roof of a building and not less than 6 m from a door, window or ventilating air opening in a building or when the condensing unit located in the building is exclusively used for ice making or cold storage together with the usual accessory rooms in connection therewith.

- (c) Group 2 Refrigerants: A mechanical refrigerating system or unit refrigerating system containing a Group 2 refrigerant shall not be located within a building unless all refrigerant containing portions of the system are enclosed in a refrigeration machinery room. Such system when installed outside of a building shall be located at least 6 m from an exit door, window or ventilating air inlet in a building.

Exception:

This shall not apply to a building used exclusively for ice making, cold storage or for the manufacturing or processing of food or drink, provided the occupant load does not exceed one person per 10 m² of floor area served by such system. Portions of refrigerating systems containing Group 2 refrigerants shall not be located in an exit.

Direct refrigeration systems containing Group 2 refrigerants shall not serve an air cooling or air-conditioning system used for human comfort.

2.10.3.3 Refrigeration machinery room

- (a) General: Required refrigeration machinery rooms shall be of at least one hour fire resistive construction. All doors shall be tight fitting. Every door shall be clearly labeled "Machinery Room". The room shall have no openings that will permit the passage of escaping refrigerant to the other parts of the building. There shall be no direct opening between a refrigeration machinery room containing Group 2 refrigerant and a room or space in which there is an open flame, spark producing device or heating surface hotter than 426°C. A refrigeration machinery room containing Group 2 refrigerants shall have at least two means of escape located at least one-fifth the perimeter of the room apart. Refrigeration machinery rooms containing Group 1 refrigerant shall have at least one exit door. Size of the exit door shall be at least 1 m by 2 m.

A refrigeration machinery room door shall open in the direction of escape.

An unobstructed working space of at least 750 mm in width and at least 2100 mm in height shall be provided around two adjacent sides of all moving machinery in a refrigeration machinery room.

- (b) Refrigeration Machinery Room Ventilation: Refrigeration machinery room shall be provided with either mechanical or gravity ventilation.
- (i) Mechanical exhaust system shall be a separate and individual system of ventilation serving no other area and shall exhaust air to outdoors at the rate of 12 air changes per hour. Exhaust air outlet shall not be located within 6m from any exterior door, window or ventilation air inlet in any building. Provisions shall be made for makeup air to replace that being exhausted. Control switch for exhaust system shall be located within the machine room and shall be readily accessible.

- (ii) Area of gravity ventilation openings to outside of the building shall not be less than one twentieth of the floor area of the machinery room but shall be more than 0.65 m². Approximately one-half of the openings shall be located within 300 mm of the floor and one half within 300 mm of the ceiling of the machinery room.
- (c) Equipment in a Refrigeration Machinery Room: Combustion air shall not be taken from a refrigeration machinery room. Electrical equipment, switch or control panel other than those used exclusively for air-conditioning, heating and ventilation system shall not be located in a refrigeration machinery room. This provision shall not apply to electrical lighting fixtures for machinery room and switches thereof.
- A readily accessible single emergency refrigeration control switch shall be provided to shut off all electrically operated machineries in a refrigeration machinery room, except the exhaust ventilation system complying with Sec 2.7.3.3. Such switch shall be located outside the machinery room, within a distance of 3 m from the machinery room exit.
- (d) First Aid Facility: Each refrigeration machinery room shall be provided with first aid boxes. Refrigeration machinery room containing Group 2 refrigerants shall be provided with two gas masks.

2.10.3.4 Refrigerant piping and equipment

- (a) Materials: Materials used in the construction and installation of refrigerating systems shall be suitable for the refrigerant in the system, and no material or equipment shall be installed which will deteriorate due to the chemical action of the refrigerant or the compressor oil, or combination of both.
- (b) Erection of Refrigerant Piping: Refrigerant piping and tubing shall be installed in such a way so as to prevent excessive vibration and strains at joints and connections. Adequate type of supports shall be used at points as required but not exceeding 4.5 m apart.

Refrigerant piping and tubing shall be installed in such a way so that it is not subject to damage from an external source.

Copper tubing containing other than Group 1 refrigerant shall not be located in a public hallway, lobby or stairway or a building unless enclosed in iron or steel piping and fittings or in rigid metal conduit.

Iron or steel refrigerant piping placed underground shall be coated with sufficient asphalt paint or equivalent material to inhibit corrosion.

- (c) Refrigerant Containers: A refrigerant receiver or evaporator or condenser shall be constructed in accordance with approved standards.

-
- (d) Valves and fittings: All valves and fittings shall be of approved type rated for the maximum operating pressure of the system.
- (e) Pressure Limiting Device: A pressure limiting device shall be installed on a positive displacement refrigerant compressor which is a portion of:
- (i) A refrigerating system containing Group 2 refrigerant.
 - (ii) An air cooled refrigerating system containing Group 1 refrigerant of 7.5 kW or more rating.
 - (iii) A water cooled refrigerating system containing Group 1 refrigerant of 2.25 kW or more rating.
- A stop or shutoff valve shall not be placed between a pressure limiting device required by this Section and the compressor it serves.
- (f) Pressure Relief Valves: The following compressors of the positive displacement type shall be equipped with a pressure relief valve:
- (i) A compressor of 15 kW or more rating which is a portion of a refrigeration system containing Group 1 refrigerant and operating at a pressure exceeding 103 kPa in the high pressure side of the system.
 - (ii) A compressor which is a portion of a refrigerating system containing a Group 2 refrigerant.
- A pressure relief valve shall be connected to the refrigerant discharge side of the compressor it serves, between such compressor and a stop valve. A stop or shutoff valve shall not be located between a pressure relief valve required by this Section and the compressor it serves.
- A pressure relief valve required by this Section that terminates outside shall discharge at a location at least 4.5 m above the adjoining ground level and at least 6 m from a window, ventilating opening or exit from a building.
- (g) Pressure Relief Devices for Pressure Vessels: A pressure vessel over 150 mm diameter which may be shutoff by valves from other parts of the system shall be equipped with a pressure relief device(s) or rupture member complying with the requirements of this Code.
- (h) Manual Discharge of Group 2 Refrigerant: A refrigerating system located in a building and containing carbon dioxide or Group 2 refrigerant shall be equipped with approved means for manual discharge of the refrigerant to the atmosphere. The discharge pipe shall terminate outside of the building not less than 2 m above the highest structure on the building and at least 6 m from any window, ventilating opening or exit from a building.

2.10.3.5 Storage of refrigerants

Refrigerants not contained in refrigeration system regulated by the Code shall be stored in original containers kept in machinery room. The total amount shall not exceed 135 kg.

A portable refrigerant container shall not be connected to the refrigerating system for a period longer than is necessary to charge or discharge the refrigerating system.

2.10.4 Cooling Tower

2.10.4.1 Location

Cooling Tower shall not be located where warm and humid air discharge from cooling tower is likely to cause damage to building structure.

2.10.4.2 Installation

Cooling tower located at roof shall meet the requirements of structures as specified in this Code. Clearances for air suction and discharge shall be maintained in accordance with the recommendation of the manufacturer of the cooling tower.

Wind speed shall be taken into consideration while designing the foundation/supports for cooling tower.

Necessary vibration isolators shall be installed to restrict transmission of machine vibration to the structure.

2.10.4.3 Access

An easy access to cooling tower located at roof shall be provided.

2.10.4.4 Waste water disposal

Cooling towers or evaporative condensers which are equipped with a positive water discharge to prevent excessive build-up of alkalinity and are used for water cooled condensing units or absorption units shall discharge the water into an approved disposal system.

2.10.4.5 Piping connections

Water supply, waste water piping and other piping connections shall comply with the provisions of the Code.

2.10.4.6 Noise

Cooling tower noise shall not be more than 65 dBA or that approved by the jurisdiction at the property boundary line. If necessary, the fan cylinder may be covered with acoustic materials to attenuate noise. Similarly floating type mat may be used to reduce the water droplet noise.

2.10.4.7 Safety

Cooling tower fan shall be protected by a strong metal screen so that no external object and/or bird can come in contact with the fan blades.

An electric isolating switch shall be installed, in a locked enclosure, at a suitable location near the cooling tower to disconnect power to the cooling tower fan when maintenance works are to be carried out.

Each cooling tower shall be provided with a securely fixed ladder to facilitate maintenance works.

2.11 Ventilation Systems

2.11.1 General

2.11.1.1 Scope

The provisions of this Section shall govern the ventilation of spaces within a building intended for human occupancy.

2.11.1.2 Where required

Every space intended for human occupancy shall be provided with ventilation by natural or mechanical means during the periods when the room or space is occupied.

2.11.2 Natural Ventilation

2.11.2.1 Sources

Natural ventilation of an occupied space shall be through windows, doors, louvers, skylights or other openings to the outdoor. Such ventilating openings shall open to the sky or a public street, space, alley, park, highway, yard, court, plaza or other approved space which comply with the requirements of the building code.

2.11.2.2 Area of ventilating openings

The minimum ventilating opening to the outdoors shall be four percent of the floor area being ventilated.

- (a) **Adjoining Spaces:** Where rooms and spaces without openings to the outdoors are ventilated through an adjoining room, the unobstructed opening to the adjoining rooms shall be at least eight percent of the floor area of the interior room or space, but not less than 2.33 m². The ventilation openings to the outdoors shall be based on the total floor area being ventilated.
- (b) **Opening below Grade:** Openings below grade shall be acceptable for natural ventilation provided the outside horizontal clear space measured perpendicular to the opening is one and one-half times the depth below the average adjoining grade.

2.11.2.3 Contaminants exhausted

Naturally ventilated spaces having contaminants present shall comply with the requirements of Sec 2.8.4.

2.11.2.4 LP-gas distribution facilities

LP-gas distribution facilities shall be provided with air inlets and outlets arranged so that air movement across the floor of the facility will be uniform. The total area of both inlet and outlet openings shall be at least 0.70 percent of the floor area. The bottom of such openings shall not be more than 150 mm above the floor.

2.11.3 Mechanical Ventilation

2.11.3.1 Where required

Mechanical ventilation shall be provided in all occupiable rooms or spaces where the requirements for natural ventilation are not met; in all rooms or spaces, which because of the nature of their use or occupancy, involve the presence of dust, fumes, gases, vapours, or other noxious or injurious impurities, or substances which create a fire hazard; where space temperature is more than 40° C; where relative humidity of inside air is more than 70 percent; where job conditions require ventilation; or where required as per provisions of this Code.

2.11.3.2 Ventilation system

Mechanical ventilation shall be provided by a method of supply air and return or exhaust air. The amount of supply air shall be approximately equal to the amount of return and exhaust air; however, the system shall not be prohibited from producing a negative or positive pressure. The ventilation system ducts and equipment shall be designed and installed in accordance with Sec 2.5.

2.11.3.3 Ventilation air quantity

The minimum amount of air circulation rate for ventilation shall be determined based on the occupant load/space area and use of the building in accordance with Table 8.2.6. The air circulation rate specified in the Table 8.2.6 shall be equal to the combined total of outside air and re-circulated air. The occupant load shall be determined in accordance with the data provided in Table 8.2.3.

Table 8.2.6 Required: Minimum Air Circulation Rate for Mechanical Ventilation of Non-Air Conditioned Space

SI. No.	Application	Air Change per Hour	SI. No.	Application	Air Change per Hour
1	Assembly rooms	4-8	28	Hospitals-sterilizing	15-25
2	Bakeries	20-30	29	Hospital-wards	6-8
3	Banks/building societies	4-8	30	Hospital domestic	15-20
4	Bathrooms	6-10	31	Laboratories	6-15
5	Bedrooms	2-4	32	Launderettes	10-15
6	Billiard rooms	6-8	33	Laundries	10-30
7	Boiler rooms	15-30	34	Lavatories	6-15
8	Cafes and coffee bars	10-12	35	Lecture theatres	5-8
9	Canteens	8-12	36	Libraries	3-5
10	Cellars	3-10	37	Living rooms	3-6
11	Churches	1-3	38	Mushroom houses	6-10
12	Cinemas and theatres	10-15	39	Offices	6-10
13	Club rooms	12, Min	40	Paint shops (not cellulose)	10-20
14	Compressor rooms	10-12	41	Photo and X-ray darkroom	10-15
15	Conference rooms	8-12	42	Public house bars	12, Min
16	Dairies	8-12	43	Recording control rooms	15-25
17	Dance halls	12, Min	44	Recording studios	10-12
18	Dye works	20-30	45	Restaurants	8-12
19	Electroplating shops	10-12	46	School rooms	5-7
20	Engine rooms	15-30	47	Shops and Supermarkets	8-15
21	Entrance halls	3-5	48	Shower baths	15-20

SI. No.	Application	Air Change per Hour	SI. No.	Application	Air Change per Hour
22	Factories and work shops	8-10	49	Stores and Warehouses	3-6
23	Foundries	15-30	50	Squash courts	4, Min
24	Garages	6-8 ^a	51	Swimming baths	10-15
25	Glass houses	25-60	52	Toilets	6-10
26	Gymnasium	6, Min	53	Utility rooms	15-20
27	Hair dressing saloon	10-15	54	Welding shops	15-30

Note: The ventilation rates may be increased by 50 percent where heavy smoking occurs or if the room is below ground.

^a Only outdoor air and no recirculation shall be done.

2.11.3.4 Minimum outdoor air

The minimum amount of the outdoor air shall be in accordance with Table 8.2.3.

Mandatory requirement: in no case the ventilation air quantity shall be lower than 2.5 l/s per person.

2.11.3.5 Air temperature

The temperature differential between ventilation air and air in the conditioned space shall not exceed 5.5°C.

Exception:

Ventilation air that is part of the air-conditioning system.

2.11.3.6 Recirculation

- (a) Amount of Recirculation: Not more than 67 percent of the required ventilation air specified in Table 8.2.6 shall be permitted for recirculation, when the concentration of particulates is less than specified in Table 8.2.7. Air in excess of the required ventilation air shall be permitted to be completely recirculated. Air shall not be recirculated to another dwelling unit or occupancy of dissimilar use.

Not more than 85 percent of the required ventilation air shall be permitted for recirculation when the system is equipped with effective adsorption or filtering equipment so that the condition of the air supplied to the room or space is within the quality limitations of Table 8.2.7.

Table 8.2.7: Maximum Allowable Contaminant Concentrations

Contaminant	Annual Average (arithmetic mean) $\mu\text{g}/\text{m}^3$	Short Term Level (not to be exceeded more than once a year) $\mu\text{g}/\text{m}^3$	Averaging Period (hours)
Particulates	60	150	24
Sulfur oxides	80	400	24
Carbon monoxide	20,000	30,000	8
Photochemical oxidant	100	500	1
Hydrocarbons (not including methane)	1,800	4,000	3
Nitrogen oxides	200	500	24
Odour	--	Essentially unobjectionable ^a	--

Note: ^a Judged unobjectionable by 60 percent of a panel of 10 untrained subjects.

- (b) Prohibited Use of Recirculated Air: Air drawn from mortuary rooms, bathrooms or toilets or any space where an objectionable quantity of flammable vapours, dust, odours, or noxious gases is present shall not be recirculated. Air drawn from rooms that must be isolated to prevent the spread of infection shall not be recirculated.

Exception:

Air drawn from hospital operating rooms may be recirculated, if the following requirements are met:

- (i) A minimum of twenty five total air changes per hour shall be provided, of which five air changes per hour shall be outdoor air.
- (ii) All fans serving exhaust systems are located at the discharge end of the system.
- (iii) Outdoor air intakes shall be located at least 7.5 m from exhaust outlets of ventilation systems, combustion equipment stacks, medical surgical vacuum systems, plumbing vent stacks or from areas which may collect vehicular exhaust and other noxious fumes. The bottom of outdoor air intakes serving central systems shall be located at least 2 m above ground level, or if installed above roof, at least 1 m above roof level.
- (iv) Positive air pressure shall be maintained at all times in relation to adjacent areas.

- (v) All ventilation or air-conditioning systems serving such rooms shall be equipped with a filter bed of 25 percent efficiency upstream of air-conditioning equipment and a filter bed of 99 percent efficiency downstream of the supply fan, any recirculating spray water systems and water reservoir type humidifiers. All filter efficiencies shall be average atmospheric dust spot efficiencies tested in accordance with the latest ASHRAE standard.
 - (vi) Duct linings shall not be used in air-conditioning and ventilation systems serving such rooms unless terminal filters of at least ninety percent efficiency are installed downstream of linings.
 - (vii) Air supplied shall be delivered at or near the ceilings and all exhaust air shall be removed near floor level, with at least two exhaust outlets not less than 75 mm above the floor.
- (c) Swimming Pool Area Recirculation: Return air from a swimming pool and deck area shall be permitted to be recirculated in accordance with Sec 2.8.3.6 when such air is dehumidified to maintain the relative humidity of the area at 60 percent or less. The return air shall only be recirculated to the area from which it was removed.

2.11.3.7 Ventilation in uninhabited spaces

Uninhabited spaces, such as crawl spaces or attics, shall be provided with natural ventilation openings as required by the Code or such spaces shall be mechanically ventilated. The mechanical ventilation system shall be a mechanical exhaust and supply air system. The exhaust rate shall be 0.1 litre per square metre of horizontal area. The ventilation system shall operate when the relative humidity exceeds 70 percent in the space.

2.11.3.8 Ventilation in enclosed parking garages

Mechanical ventilation systems for enclosed parking garages shall be permitted to operate intermittently where the system is arranged to operate automatically upon detection of vehicle operation or the presence of occupants or sensing the CO (carbon monoxide) concentration level by approved automatic detection devices.

Average concentration of CO shall not exceed 35 ppm with a maximum of 200 ppm. Automatic operation of the system shall not reduce the ventilation air flow rate below 0.25 litre per m² of the floor area and the system shall be capable of producing a ventilation air flow rate of 7.6 litre per m² of floor area. In no case the outdoor air quantity shall be lower than 5 litre per m² of floor area.

Connecting offices, waiting rooms, ticket booths and similar uses that are accessory to a public garage shall be maintained at a positive pressure.

2.11.4 Mechanical Exhaust

2.11.4.1 Where required

All rooms and areas having air with dust particles sufficiently light enough to float in the air, odours, fumes, spray, gases, vapours, smoke, or other noxious or impurities in such quantities as to be irritating or injurious to health or safety or which is harmful to building and materials or has substances which create a fire hazard, and rooms or areas as indicated in Table 8.2.6 shall have air exhausted to the outdoors in accordance with this Section.

2.11.4.2 Design of exhaust system

- (a) General: The design of the system shall be such that the emissions or contaminants are confined to the area in which they are generated by currents, hoods or enclosures and shall be exhausted by a duct system to a safe location or treated to remove contaminants. Ducts conveying explosives or flammable vapours, fumes or dusts shall extend directly to the exterior of the building without entering other spaces. Exhaust ducts shall not extend into or through ducts or plenums.

Exception:

Ducts conveying vapour or fumes having flammable constituents less than 25 percent of their lower flammability limit (LFL) may pass through other spaces.

Separate and distinct systems shall be provided for incompatible exhaust materials.

Contaminated air shall not be recirculated to occupied areas unless contaminants have been removed. Air contaminated with explosive or flammable vapours, fumes or dusts; flammable or toxic gases; or radioactive material shall not be recirculated.

- (b) Exhaust Air Inlet: The inlet to the exhaust system shall be located in the area of heaviest concentration of contaminants.
- (c) Velocity and Circulation: The velocity and circulation of air in work areas shall be such that contaminants are captured by an air stream at the area where the emissions are generated and conveyed into a product - conveying duct system. Mixtures within work areas where contaminants are generated shall be diluted below 25 percent of their lower explosive limit or lower flammability limit with air which does not contain other contaminants.

2.11.4.3 Make up air

Make up air shall be provided to replenish air exhausted by the ventilating system. Make up air intakes shall be located so as to avoid recirculation of contaminated air within enclosures.

2.11.4.4 Hoods and enclosures

Hoods and enclosures shall be used when contaminants originate in a concentrated area. The design of the hood or enclosure shall be such that air currents created by the exhaust systems will capture the contaminants and transport them directly to the exhaust duct. The volume of air shall be sufficient to dilute explosive or flammable vapours, fumes or dusts as set forth in Sec 2.11.4.2.

2.11.4.5 Exhaust outlets

The termination point for exhaust ducts discharging to the atmosphere shall not be less than the following:

- (a) Ducts conveying explosive or flammable vapours, fumes or dusts: 9 m from property line; 3 m from opening into the building; 2 m from exterior walls or roofs; 9 m from combustible walls or openings into the building which are in the direction of the exhaust discharge; 3 m above adjoining grade.
- (b) Other product conveying duct outlets: 3 m from property line; 1 m from exterior wall or roof; 3 m from openings into the buildings; 1 m above adjoining grade.
- (c) Domestic kitchen, bathroom, domestic clothes dryer exhaust duct outlets: 1 m from property line; 1 m from opening into the building.
- (d) Outlets for exhausts that exceed 80°C shall be in accordance with the relevant code.

2.11.4.6 Motors and fans

- (a) General: Motors and fans shall be sized to provide the required air movement. Motors in areas which contain flammable vapours and dusts shall be of a type approved for such environments. A manually operated remote control device shall be installed to shutoff fans or blowers in flammable vapour or dust system. Such control device shall be installed at an approved location.

Electrical equipment used in operations that generate explosive or flammable vapours, fumes or dusts shall be interlocked with the ventilation system so that the equipment cannot be operated unless the ventilation fans are in operation. Motors for fans used to convey flammable vapours or dusts shall be located outside the duct and shall be protected with approved shields and dust proofing. Motors and fans shall be accessible for servicing and maintenance.

- (b) Fans: Parts of fans in contact with explosive or flammable vapours, fumes or dusts shall be of nonferrous or non-sparking materials or their casing shall be lined or constructed of such material. When the size and hardness of materials passing through a fan could produce a spark, both the fan and the casing shall be of non-

sparking materials. When fans are required to be spark resistant, their bearings shall not be within the air stream, and all parts of the fan shall be grounded. Fans in systems handling materials that are likely to clog the blades, and fans in buffing or woodworking exhaust systems, shall be of the radial blade or tube axial type.

Equipment used to exhaust explosive or flammable vapours, fumes or dusts shall bear an identification plate stating the ventilation rate for which the system was designed.

Fans located in systems conveying corrosives shall be of materials that are resistant to the corrosion or shall be coated with corrosion resistant materials.

2.11.4.7 Exhaust systems of special areas

- (a) Motor Vehicle Operation: In areas where motor vehicles operate for a period of time exceeding 10 seconds, the ventilation return air shall be exhausted. In fuel dispensing areas, the bottom of the air inlet or exhaust opening shall be located a maximum of 450 mm above the floor.
- (b) Spray Painting and Dipping Rooms: Rooms booth for spray painting or dipping shall have mechanical exhaust systems which create a cross-sectional air velocity of 0.5 m/s. The system shall provide a uniform exhaust of air across the width and height of the room or booth. The exhaust system shall operate while spray painting or dipping is being done.
- (c) Motion Picture Projectors: Projectors equipped with an exhaust discharge shall be directly connected to a mechanical exhaust system. The exhaust system shall operate at an exhaust rate as indicated by the manufacturer's instructions.

Projectors without an exhaust shall have contaminants exhausted through a mechanical exhaust system. The exhaust rate for electric arc projectors shall be a minimum of 100 l/s per lamp. The exhaust rate for xenon projectors shall be a minimum of 150 l/s per lamp. The lamp and projection room exhaust systems, if combined or independent, shall not be interconnected with any other exhaust or return system within the building.

- (d) Dry Cleaning Equipment: Dry cleaning equipment shall be provided with an exhaust system capable of maintaining a minimum air velocity of 0.5 m/s across the face of the loading door.
- (e) LP gas Distribution Facilities: LP gas distribution facilities that are not provided with natural ventilation shall have a continuously operating exhaust system at the rate of 5 l/s per square metre of floor area. The bottom of air inlet and outlet openings shall not be more than 150 mm above the floor.

2.11.4.8 Exhaust system ducts

- (a) Construction: Ducts for exhaust systems shall be constructed of materials approved for the type of particulates conveyed and as per latest standard in this regard. Ducts shall be of substantial airtight construction and shall not have openings other than those required for operation and maintenance of the system.
- (b) Supports: Spacing of supports for ducts shall not exceed 3.7 m for 200 mm ducts and 6 m for larger ducts unless justified by the design. The design of supports shall assume that 50 percent of the duct is full of the particulate being conveyed.
- (c) Explosion Venting: Ducts conveying explosive dusts shall have explosion vents, openings protected by antflash-back swing valves or rupture diaphragms. Openings to relieve explosive forces shall be located outside the building.
- (d) Fire Protection: Fire suppression system shall be installed within ducts having a cross-sectional dimension exceeding 250 mm when the duct conveys flammable vapours or fumes.
- (e) Clearances: Ducts conveying flammable or explosive vapours, fumes or dusts shall have a clearance from combustibles of not less than 450 mm.

2.11.5 Kitchen Exhaust Equipment

2.11.5.1 Kitchen exhaust ducts

- (a) Materials: Kitchen exhaust ducts and plenums shall be constructed of at least 16 SWG steel or 18 SWG stainless steel sheet.

Joints and seams shall be made with a continuous liquid tight weld or braze made on the external surface of the duct system. A vibration isolator connector may be used, provided it consists of noncombustible packing in a metal sleeve joint of approved design. Duct bracing and supports shall be of noncombustible material securely attached to the structure and designed to carry gravity and lateral loads within the stress limitations of the Building Code. Bolts, screws, rivets and other mechanical fasteners shall not penetrate duct walls. Exhaust fan housings shall be constructed of steel.

Exception:

Kitchen exhaust ducts which are exclusively used for collecting and removing steam, vapour, heat or odour may be constructed as per provisions of Sec 2.4.1.

-
- (b) Corrosion Protection: Ducts exposed to the outside atmosphere or subject to a corrosive environment shall be protected against corrosion. Galvanization of metal parts, protection with noncorrosive paints and waterproof insulation are considered acceptable methods of protection.
- (c) Prevention of Grease Accumulation: Duct systems shall be so constructed and installed that grease cannot become pocketed in any portion thereof, and the system shall have a slope not less than 1 in 48 towards the hood or an approved grease reservoir. Where the horizontal ducts exceed 23 m in length the slope shall not be less than 1 in 12.
- (d) Air Velocity: The air velocity in the duct shall be a minimum of 7.62 m/s and a maximum of 12.7 m/s.
- (e) Cleanouts and Other Openings: Duct systems shall not have openings other than those required for proper operation and maintenance of the system. Any portion of such system having sections inaccessible from the duct entry or discharge shall be provided with adequate cleanout openings of approved construction spaced not more than 6 m apart. The cleanout shall be located on the side of the duct having a minimum opening dimension of 300 mm or the width of the duct when less than 300 mm.
- (f) Duct Enclosure: The duct which penetrates a ceiling, wall or floor shall be enclosed in a fire-resistant rated enclosure from the point of penetration in accordance with the Code. The duct enclosure shall be sealed around the duct at the point of penetration and vented to the exterior through weather-protected openings. The clearance between the duct enclosure and the duct shall be at least 75 mm and not more than 300 mm. Each duct enclosure shall contain only one exhaust duct. Approved fire rated access openings shall be provided at cleanout points.
- (g) Kitchen exhaust air flow rate shall be calculated based on the data provided in Table 8.2.8.

2.11.5.2 Kitchen exhaust hoods

- (a) A commercial exhaust hood shall be provided for each commercial cooking appliance.

Exceptions:

- (i) An appliance located within a dwelling unit and not used for commercial purposes.
- (ii) Completely enclosed ovens.
- (iii) Steam tables.
- (iv) Auxiliary cooking equipment that does not produce grease laden vapours, including toasters, coffee makers and egg cookers.

- (b) Domestic cooking appliances used for commercial purposes shall be provided with a commercial exhaust hood. Domestic cooking appliances used for noncommercial purposes shall be provided with ventilation in accordance with Sec 2.8.
- (c) Hood Construction: The hood and other parts of the primary collection system shall be constructed of galvanized steel, stainless steel, copper or other material approved by the Building Official for the use intended. The minimum nominal thickness of the galvanized steel shall be 1.2 mm (No. 18 SWG). The minimum nominal thickness of stainless steel shall be 0.93 mm (No. 20 SWG). Hoods constructed of copper shall be of copper sheets weighing at least 7.33 kg/m². All external joints shall be welded liquid tight. Hoods shall be secured in place in noncombustible supports.
- (d) Interior Surface: The interior surfaces of the hood shall not have any areas that can accumulate grease.
- Exception: Grease collection systems under fitters and troughs on the perimeter of canopy hoods.
- (e) Canopy Hoods: Canopy hoods shall be designed to completely cover the cooking equipment. The edge of the hood shall extend a minimum horizontal distance of 150 mm beyond the edge of the cooking surface on all open sides and the vertical distance between the lip of the hood and the cooking surface shall not exceed 1.22 m.
- (f) Non-canopy Type Hoods: Hoods of the non-canopy type shall be located a maximum of 900 mm above the cooking surface. The edge of the hood shall be set back a maximum of 300 mm from the edge of the cooking surface.
- (g) Hood Exhaust: The hood exhaust shall create a draft from the cooking surface into the hood. Canopy hoods attached to wall shall exhaust a minimum of 500 l/s per m² of the hood area. Canopy hoods exposed on all sides shall exhaust a minimum of 750 l/s per m² of hood area. Hoods of the non-canopy type shall exhaust a minimum of 460 l/s per lineal metre of cooking surface.
- (h) Exhaust Outlet: An exhaust outlet within the hood shall be so located as to optimize the capture of particulate matter. Each outlet shall serve not more than a 3.7 m section of the hood.

Table 8.2.8: Design Exhaust Air Flow in litre per second per kW of the Kitchen Equipment

SI No.	Kitchen Equipment	Electricity based Equipment	Gas based Equipment
1	Cooking pot	8	12
2	Pressure cooker cabinet	5	-
3	Convection oven	10	-
4	Roasting oven (salamander)	33	33
5	Griddle	32	35
6	Frying pan	32	35
7	Deep fat fryer	28	-
8	Cooker/stove	32	35
9	Grill	50	61
10	Heated table/bath	30	-
11	Coffeemaker	3	-
12	Dish washer	17	-
13	Refrigeration equipment	60	-
14	Ceramic cooker/stove	25	-
15	Microwave oven	3	-
16	Pizza oven	15	-
17	Induction cooker/stove	20	-

2.11.5.3 Make up air

Make up air shall be supplied during the operation of the kitchen exhaust system. The amount of make-up air shall be approximately equal to the amount of the exhaust air. The make-up air shall be supplied in such a way as to avoid short circuiting and reducing the effectiveness of the exhaust system. Windows and doors shall not be used for the purpose of providing make up air.

2.11.5.4 Grease removal

The air exhausted in every commercial exhaust hood shall pass through approved grease filters or grease removal device designed for the specific purpose. Grease removal devices shall bear the label of an approved agency, and shall be installed in accordance with the manufacturer's instructions for the labeled equipment. All grease filters shall be accessible. Grease filters shall be installed at a minimum angle of 45° to the horizontal. The filters shall be arranged so as to capture and drain grease to a point of collection.

2.11.5.5 Motors, fans and safety devices

- (a) Motors and fans shall be of sufficient capacity to provide required air movement. Electrical equipment shall be approved for the class of use as provided in the Code. Motors and fans shall be accessible for servicing and maintenance. Motors of the exhaust fan shall not be installed within the ducts or under hoods.
- (b) Commercial exhaust system hoods and ducts shall have a minimum clearance to combustibles of 450 mm.
- (c) Fire Suppression System Required: All commercial cooking surfaces, kitchen exhaust systems, grease removal devices and hoods shall be protected with an approved automatic fire suppression system as per the Code.

2.12 Energy Conservation

2.12.1 General

Air-conditioning, heating and ventilation systems of all buildings shall be designed and installed for efficient use of energy as herein provided. Calculations of cooling and heating loads shall be based on data which lead to a system with optimum energy use.

General standards of comfort or particular environmental requirements within the building shall not be sacrificed in an endeavor to achieve low consumption of energy. For special applications, such as hospitals, laboratories, thermally sensitive equipment, computer rooms and manufacturing processes, the design concepts and parameters shall conform to the requirements of the application at minimum energy levels.

2.12.2 Design Parameters

2.12.2.1 Outdoor design conditions

Unless specifically required, the outdoor design temperature shall be selected from columns of 2 percent value of Table 8.2.2 for cooling.

2.12.2.2 Indoor design conditions

Indoor design temperature shall not be less than 24°C for cooling unless otherwise required for specific application.

2.12.2.3 Humidity

The actual design relative humidity shall be selected from the range shown in Table 8.2.1 for the minimum total air-conditioning, heating and ventilation system energy use.

2.12.2.4 Shading co-efficient of glazing

- (a) The shading co-efficient (SC) and solar heat gain co-efficient (SHGC) shall be selected so as to reduce total heat influx through the glazing.
- (b) For any specific value of glazing to wall ratio (GWR) of any wall the shading co-efficient and solar heat gain co-efficient shall be based on the Table 8.2.9(a).

Table 8.2.9(a): SHGC and SC Values Based on GWR Value

GWR	SHGC	SC	GWR	SHGC	SC
10	0.85	0.98	60	0.33	0.38
20	0.60	0.69	70	0.31	0.36
30	0.50	0.57	80	0.30	0.34
40	0.40	0.46	90	0.27	0.31
50	0.35	0.40			

Notes:

- (i) Solar heat gain co-efficient (SHGC) = Shading Co-efficient (SC) x 0.87
- (ii) Glazing to wall ratio (GWR) = Total glazing area on any wall divided by total area of that wall including the glazing area.
- (iii) The Visible Light Transmittance (VLT) of the glazing element shall not be lower than 35 percent.

- (c) For buildings with external shading in the form of overhang and/or vertical fins a higher SHGC can be selected. The adjusted value of SHGC can be found out by using the following equation:

$$SHGC_{adj} = SHGC + A \text{ or } B \quad (8.2.1)$$

Values of A or B shall be taken from Table 8.2.9(b). Only higher of A & B shall be taken when both overhang and fins are used.

Table 8.2.9(b): Correction Factor for Overhang Shading and Vertical Fins

Value of overhang projection factor or vertical projection factor	Shading correction factor for overhang (A)	Shading correction factor for vertical fins (B)	Value of overhang projection factor or vertical projection factor	Shading correction factor for overhang (A)	Shading correction factor for vertical fins (B)
0.0	0.00	0.00	0.6	0.28	0.24
0.1	0.05	0.04	0.7	0.33	0.28
0.2	0.09	0.08	0.8	0.38	0.32
0.3	0.14	0.12	0.9	0.43	0.36
0.4	0.19	0.16	1 or higher	0.47	0.40
0.5	0.24	0.20			

Notes :

- (i) Overhead projection factor is the ratio between depth of overhang and height of window.
- (ii) Fin projection factor is the ratio between depth of fin and length of fin.
- (iii) Shading can only be counted if shade structure are placed over the window and glazing.

2.12.3 System Design

2.12.3.1 Load variation

Consideration shall be given to changes in building load and the system designed, so that maximum operational efficiency is maintained under part load conditions. The total system shall be separated into smaller zones having similar load requirements, so that each zone can be separately controlled to maintain optimum operating conditions by reducing wastage of energy.

2.12.3.2 Temperature of cooling media

The temperature of refrigerant, chilled water or brine circulated within the system shall be maintained at the level necessary to achieve the required output to match the prevailing load conditions with the minimum expenditure of energy.

2.12.3.3 Energy recovery

Energy recovery system shall be adopted, where possible.

2.12.4 Equipment and Control

2.12.4.1 General

Air-conditioning, heating and ventilation system shall be equipped with devices and controls to automatically control the capacity of the system when the building requirement reduces. The control system shall have devices to reduce energy use considering the effect of building energy storage.

2.12.4.2 Cooling with outdoor air

Each air handling system shall have facility to use up to and including 100 percent of the air handling system capacity for cooling with outdoor air automatically whenever the use of outdoor air will result in lower usage of energy than would be required under normal operation of the air handling system.

Exception:

Cooling with outdoor air is not required under any one or more of the following conditions:

- (a) Where the air handling system capacity is less than 2500 l/s or total cooling capacity is less than 40 kW.
- (b) Where the quality of outdoor air is so poor as to require extensive treatment of the air.
- (c) Where the need for humidification or dehumidification requires the use of more energy than is conserved by outdoor air cooling on an annual basis.
- (d) Where the use of outdoor air cooling would affect the operation of other systems so as to increase the overall energy consumption of the building.

2.12.4.3 Mechanical ventilation

Each mechanical ventilation system shall be equipped with a readily accessible means for either shutoff or volume reduction, and shutoff when ventilation is not required. Automatic or gravity dampers that close when the system is not operating shall be provided for outdoor air intakes and exhausts.

2.12.4.4 Maintenance

Heat exchange tubes shall be periodically cleaned to maintain its heat transfer characteristics. Maintenance of all equipment shall be periodically done to maintain its efficiency at satisfactory level.

2.12.4.5 Minimum equipment efficiencies

Cooling equipment shall meet or exceed the minimum efficiency requirements presented in Tables 8.2.10 and 8.2.11. Heating and cooling equipment not listed here shall comply with ASHRAE 90.1.

Table 8.2.10: Minimum Performance of Unitary Air Conditioning Equipment

Equipment Class and Size Category	Minimum COP	Minimum IPLV	Test Standard
Unitary air cooled air conditioner			
≥19 and <40 kW (≥5.4 and <11 tons)	3.08	--	ARI 210/240
≥40 to <70 kW (≥11 to <20 tons)	3.08	--	ARI 340/360
≥70 kW (≥20 tons)	2.93	2.99	ARI 340/360
Unitary water cooled air conditioner			
<19 kW (<5.4 tons)	4.10	--	ARI 210/240
≥19 and <40 kW (≥5.4 and <11 tons)	4.10	--	ARI 210/240
≥40 kW (≥11 tons)	3.22	3.02	ARI 210/240

Table 8.2.11: Minimum Performance of Chillers

Equipment Class and Size Category	Minimum COP	Minimum IPLV	Test Standard
Air cooled chiller, electrically operated			
<530 kW (<150 tons)	2.90	3.16	ARI 550/590
≥530 kW (≥150 tons)	3.05	3.32	ARI 550/590
Centrifugal water cooled chiller, electrically operated			
<530 kW (<150 tons)	5.80	6.09	ARI 550/590
≥530 and <1050 kW (≥150 and <300 tons)	5.80	6.17	ARI 550/590
≥1050 kW (≥300 tons)	6.30	6.61	ARI 550/590
Reciprocating compressor, water cooled chiller, electrically operated			
All Capacities	4.20	5.05	ARI 550/590
Rotary screw and scroll compressor, water cooled chiller, electrically operated			
<530 kW (<150 tons)	4.70	5.49	ARI 550/590
≥530 and <1050 kW (≥150 and <300 tons)	5.40	6.17	ARI 550/590
≥1050 kW (≥300 tons)	5.75	6.43	ARI 550/590

Equipment Class and Size Category	Minimum COP	Minimum IPLV	Test Standard
Air cooled absorption, single effect			
All Capacities	0.60	--	ARI 560
Water cooled absorption, single effect			
All Capacities	0.70	--	ARI 560
Water cooled absorption, double effect, indirect fired			
All Capacities	1.00	1.05	ARI 560
Water cooled absorption, double effect, direct fired			
All Capacities	1.00	1.00	ARI 560

2.12.4.6 Controls

- (a) All mechanical cooling and heating shall be controlled by a time clock that:
- (i) Can start and stop the system under different schedules for three different day-types per week.
 - (ii) Is capable of retaining programming and time setting during a loss of power for a period of at least 10 hours, and
 - (iii) Includes an accessible manual override that allows temporary operation of the system for up to 2 hours.
- Exceptions: (i) Cooling systems < 28 kw (8 tons); (ii) Heating systems < 7 kw (2 tons)
- (b) All heating and cooling equipment shall be temperature controlled. Where a unit provides both heating and cooling, controls shall be capable of providing a temperature dead band of 3°C (5°F) within which the supply of heating and cooling energy to the zone is shut off or reduced to a minimum. Where separate heating and cooling equipment serve the same temperature zone, thermostats shall be interlocked to prevent simultaneous heating and cooling.
- (c) All cooling towers and closed fluid coolers shall have either two speed motors, pony motors, or variable speed drives controlling the fans.

2.12.5 System Balancing**2.12.5.1 General**

Construction documents shall require that all HVAC systems be balanced in accordance with generally accepted engineering standards.

Construction documents shall require that a written balance report be provided to the owner or the designated representative of the building owner for HVAC system servicing zones with a total conditioned area exceeding 500 m² (5000 ft²).

(a) Air System Balancing

Air systems shall be balanced in a manner to first minimize throttling losses. Then, for fans with fan system power greater than 0.75 kW (1.0 hp), fan speed shall be adjusted to meet design flow conditions.

(b) Hydronic System Balancing

Hydronic systems shall be proportionately balanced in a manner to first minimize throttling losses; then the pump impeller shall be trimmed or pump speed shall be adjusted to meet design flow conditions.

Exceptions:

- (i) Impellers need not be trimmed nor pump speed adjusted for pumps with pump motors of 7.5 kW (10 hp) or less.
- (ii) Impellers need not be trimmed when throttling results in no greater than 5% of the nameplate horse power draw, or 2.2 kW (3 hp), whichever is greater.

2.12.6 Condensers**2.12.6.1 Condenser locations**

Care shall be exercised in locating the condensers in such a manner that heat sink is free of interference from heat discharge by devices located in adjoining spaces and also does not interfere with such other systems installed nearby.

2.12.6.2 Treatment water for condensers

All high-rise buildings using centralized cooling water system shall use soft water for the condenser and chilled water-system.

2.12.7 Economizers

2.12.7.1 Air side economizer: Each individual cooling fan system that has a design supply capacity over 1200 l/s (2500 cfm) and a total mechanical cooling capacity over 22 kW (6.3 tons) shall include either:

- (a) An air economizer capable of modulating outside-air and return-air dampers to supply 100 percent of the design supply air quantity as outside-air; or

- (b) A water economizer capable of providing 100% of the expected system cooling load at outside air temperature of 10°C (50°F) dry-bulb/7.2°C (45°F) wet-bulb and below:

Exception:

- (i) Projects in the hot-dry and warm-humid climate zones are exempted.
- (ii) Individual ceiling mounted fan systems <3200 l/s (6500 cfm) are exempted.

2.12.7.2 Where required by Sec 2.12.7.1 economizers shall be capable of providing partial cooling even when additional mechanical cooling is required to meet the cooling load.

2.12.8 Variable Flow-Hydronic Systems

2.12.8.1 Chilled or hot-water systems shall be designed for variable fluid flow and shall be capable of reducing pump flow rates to no more than the larger of:

- (a) 50 percent of the design flow rate, or
- (b) The minimum flow required by the equipment manufacturer for proper operation of the chillers or boilers.

2.12.8.2 Water cooled air-conditioning or heat pump units with a circulation pump motor greater than or equal to 3.7 kW (5 hp) shall have two-way automatic isolation valves on each water cooled air-conditioning or heat pump unit that are interlocked with the compressor to shut off condenser water flow when the compressor is not operating.

2.12.8.3 Chilled water or condenser water systems that must comply with either Sec 2.12.8.1 or Sec 2.12.8.2 and that have pump motors greater than or equal to 3.7 kW (5 hp) shall be controlled by variable speed drives.

2.12.9 Variable Air Flow Systems

2.12.9.1 Air conditioning air distribution system shall be designed for variable air flow and shall be capable of reducing air flow by using any or all of the following devices:

- (a) Variable speed drives for controlling speeds of fan motors,
- (b) Variable air volume units/terminals,
- (c) Dampers for regulating air flow through ducts. Dampers may preferably be motor driven and modulating type.

2.12.9.2 Air handling units that has fan capacity greater than 7.5 kW shall be controlled by variable speed drives.

Exception: Kitchen ventilation fans.

2.13 Inspection, Testing and Commissioning

2.13.1 Inspection and Testing

2.13.1.1 General

All air-conditioning, heating and ventilation system shall be inspected and tested by the Authority before the system is commissioned for normal operation. It should be ensured that these are carried out thoroughly and that all data and results are properly documented. It is recommended that whole inspection, testing and commissioning be done under the guidance and control of a single Authority.

2.13.1.2 Inspection

All machinery, equipment and other accessories of the air-conditioning, heating and ventilation system shall be inspected by the Authority to determine whether the system components and the system as a whole has been installed as per design and provisions of this Code; proper safety requirements have been maintained; and adequate fire protection measures have been taken.

Inspection shall also be carried out on structural supports, hangers, fastening devices, vibration isolators etc.

2.13.1.3 Testing

- (a) General: All machinery, equipment and other accessories shall be tested as per approved procedures. Tests shall be conducted to determine the strength capacity of any item and performance of any machine and equipment. All test data shall be properly documented.
- (b) Pressure Testing of Piping: All field installed refrigerant and hydronic piping system along with their valves and pipe fittings shall be tested at their approved test pressures to determine whether the piping system can withstand the test pressures.
- (c) Air Distribution System Testing: All ducting system shall be tested to determine whether the duct system has any leakage at test pressures. All air terminals and air dampers shall be tested for their flow characteristics.
- (d) Machinery and Equipment: Tests shall be conducted on machinery and equipment to determine whether these operate and function properly. All machinery and equipment shall also be tested for their electrical power consumption characteristics and overall performance. Before performance testing of the system all air distribution system and hydronic system shall be properly balanced by approved procedure.
- (e) Safety Devices and Controls: Tests shall be carried out to determine whether the safety devices and controls function properly.
- (f) All air filters shall be tested in accordance with the latest standard.

2.13.2 Commissioning

If the Authority becomes satisfied regarding satisfactory installation and performance of the air-conditioning, heating and ventilation system after testing, the system shall be commissioned following approved procedure. Before complete commissioning, all air distribution systems and hydronic systems shall be properly balanced and all the controls and their sensors shall be properly adjusted.

2.14 Operation and Maintenance

2.14.1 General

The owner of the building where the air-conditioning, heating and ventilation system is installed, shall follow a properly designed operation procedure and maintenance schedule.

2.14.2 Operation

A well sequenced operation procedure shall be followed to ensure effective operation of the air-conditioning, heating and ventilation system, safety from hazard to personnel and property. Operation procedure shall take account for saving in energy use.

All operational data of all the machinery and equipment shall be properly recorded for determination of performance of the machinery, equipment and the system. These data shall be properly preserved for future reference for maintenance purposes.

2.14.3 Maintenance

A well designed maintenance program for the air-conditioning, heating and ventilation system shall be implemented in order to achieve the following:

- (a) Optimum reliability and continuity of service.
- (b) Extended longevity and economic life.
- (c) Functional effectiveness, whereby the intended performance of mechanical equipment and system can be fully attained.
- (d) Minimum operating cost, attendant requirements, servicing and repairs.
- (e) Safety from hazard to personnel and property.

Maintenance program and procedure shall comply with the instructions of machinery/equipment manufacturers in this regard.

PART VIII
Chapter 3
Building Acoustics

3.1 Purpose

The purpose of this Chapter is to provide codes, recommendations and guidelines for fulfilling acoustical requirements in buildings.

3.2 Scope

This Chapter specifies planning, design and construction codes, recommendations and guidelines on spatial, architectural and technical aspects of acoustics within or outside buildings to ensure acoustical performance, comfort and safety. Planning and design aspects are discussed generally and also particularly for buildings with different occupancies.

3.3 Terminology

This Section provides meanings and definitions of terms used in and applicable to this Chapter of the Code. The terms are arranged in alphabetical order. In case of any contradiction between a meaning or a definition given in this Section and that in any other part of the Code, the meaning or definition specified in this Section shall govern for interpretation of the provisions of this Section.

BALANCED NOISE CRITERIA (NCB) CURVES	Balanced Noise Criteria (NCB) curves are used to specify acceptable background noise levels in occupied spaces (see Appendix F).
BEL	See sound pressure level.
CYCLE	See Frequency.
dBA	A sound pressure level measurement, when the signal has been weighted with a frequency response of the A curve. The dBA curve approximates the human ear and is therefore used most in building acoustics.
DECIBEL (dB)	See sound pressure level.
DIRECT SOUND	Sound that travels directly from a source to the listener or receiver. In a room, the sequence of arrivals is the direct sound first, followed by sound reflected from room surfaces.
ECHO	Echo is a reflection of a sound wave back to its source in sufficient strength and with a sufficient time lag to be separately distinguished. Usually, a time lag of at least 50 to 80 ms is required for hearing discrete echoes.

EFFECTIVE PERCEIVED NOISE LEVEL IN DECIBEL (EPN dB)	The number for rating the noise of an individual aircraft flying overhead is the Effective Perceived Noise Level in decibels (unit, <i>EPN dB</i>). This value takes into account the subjectively annoying effects of the noise including pure tones and duration. In principle, it is a kind of time-integrated loudness level.
FLUTTER ECHO	A quick succession of echoes; it may be present as a disturbing phenomenon in small rooms or between a pair of parallel reflectors. If the time between echoes is greater than about 30 to 50 ms, the periodicity is audible as a distinct flutter.
FREQUENCY	The frequency of sound is the number of vibrations per second of the molecules of air, generated by the vibrating body. One complete movement to and fro of the vibrating body is referred to as a 'cycle'. Frequency is expressed as the number of cycles per second (cps); it is also referred to its unit as <i>Hertz (Hz)</i> .
IMPACT ISOLATION CLASS (IIC)	Impact Isolation Class (IIC) is a single-number impact isolation rating for floor construction. Tests are made with a standard tapping machine and noise level measured in 1/3-octave bands. These are plotted and compared to a standard contour.
INTENSITY	Intensity at a point is the average rate at which sound energy is transmitted through a unit area around the point and perpendicular to the direction of propagation of sound. It is also known as sound intensity. Its units is $W m^{-2}$.
L_{10}	In environmental noise assessment, the A-weighted noise level (unit dBA), with fast (F) time weighting, that is exceeded by 10 percent of sated time period is known as L_{10} .
$L_{Aeq,T}$	Expression for Equivalent Continuous A-Weighted Sound Pressure Level for airborne sounds that are non-stationary with respect to time. It is formed by applying A-weighting to the original signal before squaring and averaging. Also known as equivalent continuous sound level.
LOUDNESS	Loudness is the sensation produced in the human ear and depends on the intensity and frequency of sound. The unit of loudness level is <i>phon</i> .

NOISE	Noise is defined as unwanted sound. Noise conditions vary from time to time and a noise which may not be objectionable during the day may be increased in annoying proportions in the silence of the night, when quiet conditions are essential.
NOISE EXPOSURE FORECAST (NEF)	Noise exposure forecast at any location is the summation of the noise levels in Effective Perceived Noise Level (unit <i>EPN dBA</i>) from all aircraft types, on all runways, suitably weighted for the number of operations during day time and night time.
NOISE MAP	A noise map is a graphic representation of the sound level distribution existing in a given region, for a defined period.
NOISE REDUCTION (NR)	Noise Reduction (<i>NR</i>) is a general term for specifying sound insulation between rooms. It is more general than Transmission Loss (<i>TL</i>). If all boundary surfaces in the receiving room are completely absorbent, the <i>NR</i> will exceed the <i>TL</i> by about 5 <i>dB</i> , i.e. $NR = TL + 5dB$.
PERCENTAGE SYLLABLE ARTICULATION (PSA)	The percentage of meaningless syllables correctly written by listeners is called Percentage Syllable Articulation (PSA).
REVERBERATION	The prolongation of sound, as a result of successive reflections in an enclosed space, when the source of the sound has stopped, is called reverberation.
REVERBERATION TIME (RT)	The reverberation time of a room is defined as the time required for the sound pressure level in a room to decrease by 60 <i>dB</i> after the sound is stopped, and is calculated by the formula $RT = \frac{0.16V}{A + xV}$ <p>Where, RT= reverberation time, s</p> <p style="margin-left: 40px;">V= room volume, m³</p> <p style="margin-left: 40px;">A= total room absorption, m² <i>sabin</i></p> <p style="margin-left: 40px;">x= air absorption coefficient</p>
SIGNAL-TO-NOISE	Signal-to-Noise Ratio (SNR) defined as the power ratio

RATIO (SNR) between a signal (meaningful information) and the background noise (unwanted signal), which can be expressed as

$$\text{SNR} = (P_{\text{signal}}/P_{\text{noise}})$$

where, P is average power

SNR can be obtained by calculating the square of amplitude ratio:

$$\text{SNR} = (P_{\text{signal}}/P_{\text{noise}}) = (A_{\text{signal}}/A_{\text{noise}})^2$$

where, A is root mean square (RMS) amplitude

In decibel, the SNR is defined as

$$\text{SNR}_{\text{dB}} = 10 \log_{10} (P_{\text{signal}}/P_{\text{noise}}) = P_{\text{signal,dB}} - P_{\text{noise,dB}}$$

which might be equivalently expressed in amplitude ratio as

$$\text{SNR}_{\text{dB}} = 10 \log_{10} (A_{\text{signal}}/A_{\text{noise}})^2 = 20 \log_{10} (A_{\text{signal}}/A_{\text{noise}})$$

SOUND FOCUS
AND DEAD SPOT

When a sound wave is reflected by a concave surface, large enough compared to the wavelength, it concentrates on a spot where sound pressure rises excessively. This is called a 'sound focus'. As a consequence, sounds become weak and inaudible at some other spots, called 'dead spots'.

SOUND PRESSURE
LEVEL (SPL)

Sound Pressure Level or Sound Intensity Level is measured in terms of the unit *bel* (B), which is defined as the logarithm of the ratio of the sound pressure to the minimum sound pressure audible to the average human ear. The unit *decibel* (dB) is one-tenth of a *bel* (B). Thus,

$$\text{Sound Pressure Level} = \log_{10} \frac{1}{I_0} \text{ bcls} = 10 \log_{10} \frac{1}{I_0} \text{ dccibcls}$$

where,

I = Sound Pressure in watt cm^2 , and

I_0 = Sound Pressure audible to the average human ear taken as 10^{-16} watt/ cm^2 .

SOUND TRANSMISSION CLASS (STC)	To avoid the misleading nature of an average transmission loss (TL) value and to provide a reliable single figure rating for comparing partitions, a different procedure for single figure rating, called Sound Transmission Class (STC) rating, of a partition is determined by comparing the 16 frequency TL curve with a standard reference contour, the sound transmission class contour. STC ratings of some common walls and floors are given in Appendix E.
SPEECH INTELLIGIBILITY	The percentage of correctly received phrases is called Speech Intelligibility.
TRANSMISSION LOSS	Transmission loss (TL) of a partition is a measure of its sound insulation. It is equal to the number of decibels by which sound energy is reduced in passing through the structure. Units <i>dB</i> .
WAVELENGTH	The wavelength of sound is the distance over which a complete cycle occurs. It can be found by measuring distance between the centres of compression of the sound waves. It is dependent upon the frequency of the sound.

3.4 Building Acoustics: General Considerations and Provisions

Generalised considerations and provisions for planning and design of building are furnished in this Section.

3.4.1 Classifications of Building Acoustics

3.4.1.1 Considering diversity of desired objectives and salient design features, building acoustics can be broadly classified as,

- (a) Acoustics for Speech
- (b) Acoustics for Music
- (c) Acoustics for Multipurpose

Table 8.3.1 shows classifications of acoustics with brief description and examples of spaces involved.

Table 8.3.1: Classifications of Building Acoustics, Brief Description and Examples of Spaces Involved

Classifications	Brief Description	Examples of Spaces
(a) Acoustics for Speech	Relates to speech with foremost objectives of intelligibility. A space should have relatively lower reverberation time for speech. Generally, it covers narrow range of frequency spectra in lower-mid level (about 170 to 4,000 Hz, for an average dynamic range of 42 dBA).	Classroom, lecture hall, conference hall, recital hall, assembly hall, courtroom, auditorium for speech etc.
(b) Acoustics for Music	Involves music with prime objectives of liveliness or reverberance, intimacy, fullness, clarity, warmth, brilliance, texture, blend and ensemble. Music may include instrumental and vocal melody, or either of the two. A space requires relatively higher reverberation time for music. Generally, it involves broad range of frequency spectra (about 50 to 8,500 Hz, for an average dynamic range of about 75 dBA).	Music practice booth, rehearsal room, band room, listening booth, orchestra, concert hall, symphony hall, cathedral etc.
(c) Acoustics for Multipurpose	Includes both speech and music acoustics to fulfil objectives of the both at a rationally compromised level. Acoustics design of a multipurpose space is quite challenging as the design objectives and measures vary remarkably for speech and music. For example, there is a significant variation in desired reverberation times of a space for speech and music.	Multipurpose hall, cinema, theatre, opera house, mosque (for speech and melodious recitation), church, temple etc.

3.4.1.2 A building or a building complex is usually a group of spaces or rooms intended for various functions. Those spaces may require involvement of different types of acoustics as stated in Table 8.3.1. For example, a school has spaces for speech (e.g., classroom), music (e.g., music room) and multipurpose (e.g., auditorium). Thus, a building or a building complex should not be generally classified as a whole for a particular type of acoustics, rather its spaces or rooms shall be classified individually and appropriate acoustical design shall be considered accordingly.

3.4.1.3 Spaces or rooms of a building or a building complex, if those even have different types of acoustical requirements, shall be designed in such a way, so that those can coexist and work as a whole.

3.4.2 Acoustical Planning and Design Targets

3.4.2.1 A space, involving either of the acoustical types stated in Sec 3.4.1, must achieve few design targets. Some of these important design targets are mentioned below:

- (a) Noise exceeding allowable limit should be controlled
- (b) Speech intelligibility should be satisfactory
- (c) Music should have liveliness, intimacy, fullness, clarity, warmth etc.
- (d) The desired sound level must be optimum to be heard properly
- (e) Diffusion of sound throughout the whole space
- (f) There should be no defects such as echoes, flutter echoes etc.

3.4.2.2 Necessary planning and design measures shall be taken for achieving these targets to optimum levels or standards as dictated in this Code.

3.4.3 Factors Affecting Acoustical Planning and Design

3.4.3.1 Among many, following are the most significant factors affecting acoustical planning and design; noise, reverberation time, sound level and diffusion of sound.

3.4.3.2 For various types of building acoustics, as stated in Sec 3.4.1, the effects of these factors might be different. These factors are dependent on different conditions, like noise and sound level, room volume, building materials, surface materials, sound levels, room geometry etc.

3.4.4 General Considerations and Provisions for Planning, Design, Assessment and Construction

3.4.4.1 In Appendix F, a flow diagram summarises activities required for planning, design, assessments and construction related to building acoustics.

3.4.4.2 Acoustical planning and design, including all parts and details, shall be performed during design phase of any project and must comply with standards and codes as dictated in this Code.

3.4.4.3 During planning and design phase, the expected results for acoustical performance of a space or a room or building, as dictated in different Sections of this Chapter, shall be precisely analysed and assessed through standard practice, for example, precise computational methods based on computer analysis, simulation and prediction techniques.

3.4.4.4 Acoustical planning and design targets and expected results shall be clearly specified and documented as a part of the design proposal.

3.4.4.5 Acoustical planning and design measures shall be compatible with requirements of other environmental factors including natural light, ventilation and heat for working in an overall synergy.

3.4.4.6 Acoustical planning and design measures shall be congenial to other design parameters including function, structure and aesthetics for an overall harmony in design.

3.4.4.7 The proposal for acoustical design, materials, devices, supporting structures and construction methods shall be safe for health during construction and post-construction occupancy.

3.4.4.8 Acoustical materials, devices and supporting structures shall be safe in case of disasters including earthquake and fire.

3.4.4.9 The acoustical design measures and materials shall be reasonably energy efficient and compatible with Green Building practice.

3.4.4.10 Acoustical materials shall be eco-friendly, recyclable and should require minimum maintenance. Those shall be compliant to sustainable acoustics in particular and sustainable building practice in general.

3.4.4.11 It is recommended to conduct peer supervisions and periodic assessments at different phases of construction process to rectify any drawback at its initial stage.

3.4.4.12 Post-construction and post-occupancy assessments shall be conducted and findings shall be compared with expected results. Assessment shall include instrumental measurements and opinion survey of occupants. If any discrepancy is found, the space shall be modified until it reaches reasonably close to the expected result.

3.4.4.13 Preceding provisions shall be applicable for modifications of a space to eliminate acoustical faults, retrofitting a space for acoustical performance or any other acoustical design and construction activities.

3.4.4.14 Form G, Checklist: Acoustical Planning, Design and Post-occupancy Assessments, as in Appendix G, shall be filled in and signed by the acoustical consultant for each acoustical space or room or building of any project.

3.5 Planning and Design For Noise Control

3.5.1 Types of Noise

3.5.1.1 Depending on location of source, noise might be of two types:

(a) Outdoor Noise.

Following are some common sources of outdoor noise:

- (i) Traffic noise generated from air traffic, road traffic, rail traffic etc. (see Appendix H)
- (ii) Noise from zones and buildings within built-up areas, machinery, appliances, construction activity, loudspeakers, people, animals etc.

(b) Indoor Noise.

Following are some common source of indoor noise:

- (i) Household appliances, machinery, footsteps on floor, air conditioner duct etc.
- (ii) Activities performed by occupants, like people, pets etc.

3.4.2.2 Basing on transmission path, noise can be classified as

(a) Airborne Noise

Examples noise from appliances, car horn, telephone ring etc.

(b) Structure-borne Noise

Example footsteps, slamming of door, furniture movement, vibrating mechanical equipment etc.

3.5.2 Design Sequence for Noise Control

3.5.1.1 In order to achieve noise control effectively, measures should be taken in the following order:

- (a) Suppression of noise generation at its source
- (b) Layout planning
- (c) Insulation design
- (d) Absorption design

3.5.3 Planning and Design for Outdoor Noise Control

3.5.3.1 Planning to control outdoor noise is an integral part of country and town planning ranging from regional to detailed zoning and three dimensional layouts of built form and traffic routes.

3.5.3.2 Noise causes more disturbances to people at rest than those at work. For this reason, outdoor noise levels in various zones or areas should be considered in planning and design with respect to critical hours of space occupancy (see Table 8.H.1, Appendix H).

3.5.3.3 Planning and design of buildings shall consider all sources of noise mentioned in Sec 3.5.1 and keep provisions to control those from transmitting in and around buildings. For example, the orientation of buildings might be decided in way to reduce the noise disturbance from noisy neighbourhood.

3.5.3.4 A noise survey shall be conducted and a Noise Map shall be prepared to identify source, type, intensity, frequency and other parameters of noise in and around the site of any specific project. Noise levels should be measured for pick and off pick hours of both working and holidays, and also for 'Day Time' and 'Night Time' as defined in 'Noise Pollution (Control) Rules 2006' and its subsequent amendments by the Government of the People's Republic of Bangladesh (see Table 8.H.1, Appendix H). The noise levels shall be analysed statistically for value of L_{10} , $L_{Aeq,T}$ etc.

3.5.3.5 A Noise Map shall be used to examine compliance to the permissible upper limit of noise levels set for different land use zones in the 'Noise Pollution (Control) Rules 2006' and its subsequent amendments by the Government of the People's Republic of Bangladesh (see Table 8.H.1, Appendix H). As references, intensity levels of some common noise are shown in (see Table 8.H.3, Appendix H).

3.5.3.6 The planning should be undertaken in such a manner that the noise can be kept at a distance. Quiet zones and residential zones should be placed with adequate setback from noise sources, like airports, highways, railway lines and factories. It might be useful to note that doubling the distance drops the sound pressure level by about 6 dBA.

3.5.3.7 Buildings (or parts of buildings) which are considered to be especially susceptible to noise, including hospitals, research laboratories, recording studios or the like, should not be sited near sources of noise.

3.5.3.8 It might be a preferable option to place a noise tolerant buffer zone, developing green belt, public gardens etc. between a noisy zone and a quiet zone.

3.5.3.9 Noise barriers might be provided by placing buildings and occupancies less susceptible to noise between the source and the more susceptible ones. Purpose built noise barriers made of bricks, concrete, fibreglass, fibre reinforced plastic or other materials can also be used to protect buildings from noise.

3.5.3.10 If noise barriers (as stated in Sec 3.5.3.9) is neither attainable nor adequate, a building itself should have all necessary measures to protect itself against outside noise. The following might be some options:

- (a) In zoning of spaces, noise tolerant spaces might be placed near a noise source, while placing less-tolerant spaces at a distance.
- (b) External walls or partitions should have appropriate Sound Transmission Class (STC) to reduce external noise to the acceptable indoor background noise levels (Tables 8.3.3 to 8.3.6, 8.E.1 and 8.E.2, Appendix E)
- (c) Preferably, external walls near source of noise should not have any operable window. However, to meet the demand of natural light, fixed windows allowing only light might be placed with proper noise insulation measures.
- (d) If need for operable windows allowing natural light and ventilation are inevitable in external walls near source of noise, special measures should be taken for restricting noise while allowing light and ventilation. Acoustic louvers, active noise cancellation devices etc. are examples of these types of special measures.
- (e) If natural ventilation is required but natural light is not required, ventilation ducts or chutes with lining of acoustic absorbers might be designed in a manner to absorb noise while air flows through.

3.5.3.11 Following special provisions shall be applicable for air traffic noise:

- (a) No building for human occupancy shall preferably be constructed, where NEF value due to air traffic noise exceeds 40 EPN dBA. As a reference, typical noise levels of some aircraft types are shown in Table 8.H.2, Appendix H.
- (b) Educational institutions, hospitals, auditoriums etc. shall preferably be located at places where the value of NEF is less than 25 EPN dBA.
- (c) In areas exposed to less than 90 EPN dBA, all of the windows shall be closed and properly sealed, having double glazing, in order to provide an acceptable interior noise environment.
- (d) Industrial and commercial activities generating high interior noise environments might be located in areas exposed to noise levels greater than 90 EPN dBA.
- (e) In airport areas of highest noise levels, sparsely manned installations like sewage disposal plants, utility substations and similar other facilities might be located.

3.5.3.12 Following provisions shall be applicable for road traffic noise:

- (a) For road traffic noise level, the value of L_{10} shall be limited to a maximum of 70 dBA for zoning and planning new buildings in urban areas, while dwellings are proposed to have sealed windows.
- (b) The maximum permissible upper limit of L_{10} shall be reduced to 60 dBA when the dwellings are proposed to have open windows.
- (c) Major new residential developments shall preferably be located in areas with L_{10} levels substantially lower than those specified above.
- (d) Where L_{10} is greater than 70 dBA, design solutions such as barrier blocks, noise buffers or purpose built noise barriers shall be utilized in order to reduce noise levels at least to that level.
- (e) Through traffic roads shall preferably be excluded from quiet and residential zones to avoid excessive traffic noise.
- (f) In the neighbourhood of residential, educational, institutional and health care buildings, legislative control shall be exercised for road noise particularly from vehicles as dictated in 'Noise Pollution (Control) Rules 2006' and its subsequent amendments by the Government of the People's Republic of Bangladesh.

3.5.3.13 Following special provisions shall be applicable for rail traffic noise:

- (a) No residential or public building, except for the railway station and its ancillary structures, shall preferably be connected to the railway lines.
- (b) Mercantile or commercial buildings should not abut the railway lines or the marshalling yards. Only planned industrial zones may be located beside the railway tracks.
- (c) In order to reduce the high noise levels, produced at the arrival and departure of trains, platforms in railway stations shall be treated with sound absorbing materials particularly on the ceiling.
- (d) The main platform floor shall be separated from the station building with a minimum gap of 50 mm so that the ground or structure-borne vibrations are not transmitted to the building.
- (e) Windows and other openings shall preferably be placed as less as possible in the facade along the railway tracks.
- (f) Greenbelts, landscaping or any other form of barrier might be developed along the railway lines.

3.5.3.14 Construction noise shall be controlled according to the 'Noise Pollution (Control) Rules 2006' and its subsequent amendments by the Government of the People's Republic of Bangladesh.

3.5.4 Planning and Design for Indoor Noise Control

3.5.4.1 The allowable upper limits of indoor background noise levels (in dBA) are as shown in Table 8.3.2 and Figure 8.D.1 in Appendix D. Design shall comply with recommended range of Balanced Noise Criteria (NCB) Curve for different types of activity.

Table 8.3.2: Allowable Upper Limit of Indoor Background Noise Levels and Recommended Range of NCB Curves

Type of Space	dBA	NCB Curve
Broadcast and recording studios (distant microphone used)	18	10
Concert halls, opera houses, and recital halls	18-23	10-15
Large theatres and auditoriums, mosques, temples, churches and other prayer spaces	<28	<20
Television and recording studio (close microphone used)	<33	<25
Small theatres, auditoriums, music, rehearsal rooms, large meeting and conference rooms	<38	<30
Bedrooms, hospitals, hotels, residences, apartments, etc.	33-48	25-40
Classrooms, libraries, small offices and conference rooms. Living rooms, and drawing rooms in dwellings	38-48	30-40
Large offices, receptions, retail shops and stores, cafeterias, restaurants, indoor stadiums, gymnasium, large seating-capacity spaces with speech amplification	43-53	35-45
Lobbies, laboratory, drafting rooms, and general offices	48-58	40-50
Kitchens, laundries, computer and maintenance shops	53-63	45-55
Shops, garages, etc. (for just acceptable telephone conversation)	58-68	50-60
For work spaces where speech is not required	63-78	55-70

3.5.4.2 Noise generated from within a building shall not be transmitted to neighbourhood at a noise level higher than the allowable upper limit set for that zone (see Table 8.H.1, Appendix H).

3.5.4.3 Buildings, in which there are some sources of noise, shall have buffers separating the noise producing area from the other areas. The less vulnerable areas of the building may be planned to act as noise buffers.

3.5.4.4 In the assessment of indoor noise levels, direct sound shall be separated from reverberant sound.

3.5.4.5 The reverberant sound transmitted from one room to another shall be cut down by employing suitable sound absorption materials and by structural and non-structural partitions.

3.5.5 Sound Insulation

3.5.5.1 The recommended sound insulation criteria are classified in some Grades. The STC value for airborne sound insulation is graded as stated below (see also, Figure 8.D.2, Appendix D):

- (a) Grade I STC = 55 Apply mainly to fully residential, quiet rural and suburban areas and in certain luxury apartment buildings.
- (b) Grade II STC = 52 Apply to residential spaces in relatively noisy environments, typical of urban and suburban areas.
- (c) Grade III STC = 48 Express minimal requirements applicable to very noisy locations, such as commercial or business areas, like shop houses with dwelling units on the upper floors, or downtown areas.

3.5.5.2 Transmission of sound should be controlled with appropriate material, assembly of building elements. Typical STC rating for different types of building element, like stud partitions, masonry walls, doors, windows and interior partitions are shown in Table 8.E.1, Appendix E.

3.5.5.3 Recommended STC for partitions for specific occupancies are shown in Table 8.E.2, Appendix E.

3.5.6 Control of Structure-borne Impact Noise

3.5.6.1 Impact noise problems can be controlled in following ways:

- (a) Preventing or minimising the impact by cushioning the impact with resilient materials, like floor tiles of rubber and cork, carpeting on pads with desired Impact Isolation Class (IIC). Criteria for airborne and impact sound insulation of floor-ceiling assemblies between dwelling unit, Tables 8.3.3 and 8.3.4.

- (b) Floating the floor for isolating the impacted floor from the structural floor by a resilient element is extremely effective. This element can be rubber or mineral wood pads, blankets or special spring metal sleepers.
- (c) Suspending the ceiling and using an absorber in the cavity.
- (d) Isolating all rigid structures, such as pipes, and caulking penetrations with resilient sealant.

Table 8.3.3: Airborne Sound Insulation of Partitions between Dwelling Units

Apt. A	Apt. B	Grade II STC	Apt. A	Apt. B	Grade II STC
Bedroom	to Bedroom	52	Bathroom	to Living room	54
Living room	to Bedroom ^a	54	Corridor	to Living room ^{a,c,d}	52
Kitchen ^b	to Bedroom ^a	55	Kitchen	to Kitchen ^e	50
Bathroom	to Bedroom ^a	56	Bathroom	to Kitchen	52
Corridor	to Bedroom ^{a,c}	52	Corridor	to Kitchen ^{a,c,d}	52
Living room	to Living room	52	Bathroom	to Bathroom	50
Kitchen ^b	to Living room ^a	52	Corridor	to Bathroom ^{a,c}	48

Notes:

For Grade I, add 3 points; for Grade III, subtract 4 points.

^a Whenever a partition wall may serve to separate several functional spaces, the highest criterion must prevail.

^b Or dining or family or recreation room.

^c It is assumed that there is no entrance door leading from the corridor to the living unit.

^d Criterion applies to the partition. Doors in corridor partition must have the rating of partition, not vice versa.

^e Double wall construction is recommended to minimise kitchen impact noise.

Table 8.3.4: Airborne and Impact Sound Insulation of Floor-Ceiling between Dwelling Units

Apt. A	Apt. B	Grade II STC	Grade II IIC	Apt. A	Apt. B	Grade II STC	Grade II IIC
Bedroom	above Bedroom	52	52	Living room	above Kitchen ^{c,e}	52	52
Living room	above Bedroom ^a	54	57	Kitchen	above Kitchen ^c	50	52
Kitchen ^b	above Bedroom ^{a,c}	55	62	Bathroom	above Kitchen ^{a,c}	52	52
Family room	above Bedroom ^{a,d}	56	62	Family room	above Kitchen ^{a,c,d}	52	58
Corridor	above Bedroom ^a	52	62	Corridor	above Kitchen ^{a,c}	48	52
Bedroom	above Living room ^e	54	52	Bedroom	above Family room ^e	56	48
Living room	above Living room	52	52	Living room	above Family room ^e	54	50
Kitchen	above Living room ^{a,c}	52	57	Kitchen	above Family room ^e	52	52
Family room	above Living room ^{a,d}	54	60	Bathroom	above Bathroom ^c	50	50
Corridor	above Living room ^a	52	57	Corridor	above Corridor	48	48
Bedroom	above Kitchen ^{c,e}	55	50				

Notes:

For Grade I, add 3 points; for Grade III, subtract 4 points.

- ^a Arrangement requires greater impact sound insulation than inverse, where a sensitive area is above less sensitive area.
- ^b Or dining or family or recreation room.
- ^c It is assumed that the plumbing fixtures, appliances and piping are insulated with proper vibration isolation.
- ^d The airborne STC criteria in this table apply as well to vertical partitions between these two spaces.
- ^e This arrangement require equivalent airborne sound insulation than the converse.

3.5.7 Control of Electro-Mechanical System Noise

3.5.7.1 Mechanical noise is generated from mechanical devices like air-conditioning and air-handling systems, lifts, escalators, pumps, electric generators etc.

3.5.7.2 Mechanical noise problems can be controlled in following ways:

- (a) Reducing the vibration of electro-mechanical equipment by damping and isolation.
- (b) Reducing the airborne noise by decoupling the vibration from efficient radiating sources.
- (c) Decoupling the vibrating source from the structure.
- (d) In air-conditioning duct system, smooth transitions at changes of duct size, large radius bends, lining with absorbing materials etc. are effective measures.
- (e) Active noise cancellation technique, by producing a synthesised signal exactly out-of-phase with the original noise signal to make the resultant signal effectively zero, might be applied in special cases.

3.5.8 Occupational Noise Exposure

3.5.8.1 Protection against the effects of noise exposure shall be provided when the sound level exceeds those shown in Table 8.3.5.

3.5.8.2 Exposure to impulsive or impact noise should not exceed 140 dBA peak sound level.

Table 8.3.5: Permissible Noise Exposure

Sound Level dBA (slow response)	Duration per Day Hour - Minute	Sound Level dBA (slow response)	Duration per Day Hour - Minute
85	16-00	98	2-50
86	13-56	99	2-15
87	12-08	100	2-00
88	10-34	101	1-44
89	9-11	102	1-31
90	8-00	103	1-19
91	6-58	104	1-09
92	6-04	105	1-00
93	5-17	106	0-52
94	4-36	107	0-46
95	4-00	108	0-40
96	3-29	109	0-34
97	3-02	110	0-30

Notes:

- (i) The sound level should be measured on *A* scale at slow response.
- (ii) When the daily noise exposure is composed of two or more periods of noise exposure of different levels, their combined effect should be considered, rather than the individual effect of each. If the sum of the following fractions: $C_1/T_1 + C_2/T_2 + \dots + C_n/T_n$ exceeds unity, then, the mixed exposure should be considered to exceed the limit value. C_n indicates the total time of exposure permitted at that time.

3.6 Reverberation Time, Sound Pressure Level and Diffusion of Sound

3.6.1 General Considerations

- (a) For an overall performing, comfortable and safe acoustical environment, along with the issues of noise, other significant aspects of acoustics should be considered. This shall include sound pressure level, reverberation time and diffusion of sound.
- (b) Speech intelligibility is a significant parameter to achieve satisfactory acoustical design. Percentage Syllable Articulation (PSA) is an index for assessing speech intelligibility. PSA can be expressed as

$$PSA = 96 k_i k_r k_n k_s (\%) \quad (\text{for English Language})$$

$$PSA = 93 k_i k_r k_n k_s (\%) \quad (\text{for Bangla Language})$$

Where,

k_i , k_r , k_n and k_s are the coefficient for average speech level, Reverberation Time, Noise level/ Speech level and room shape, respectively (see Figure 8.I.1, Appendix I).

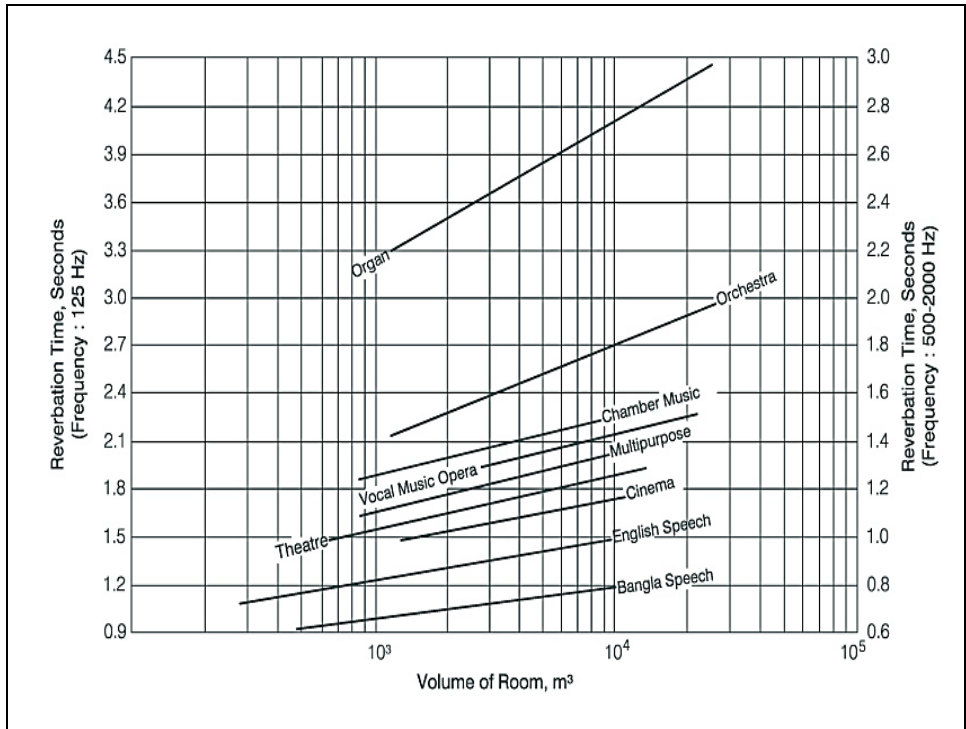
- (c) For a PSA of 82%, almost a perfect Speech Intelligibility (nearly 100%) can be achieved. However, in reality, there are some background noise (>20 dBA) and reverberation time in different spaces, causing lower PSA. The minimum admissible PSA should be 75% for a satisfactory Speech Intelligibility.

3.6.2 Reverberation Time

Spaces for various uses should be designed for recommended optimum reverberation time to achieve a level of intelligibility and liveliness (see Figure 8.3.1).

3.6.3 Sound Pressure Level

- (a) In a space with a low background noise (<20 dBA) and a minimum Reverberation Time (close to 0.0 s), a maximum Percentage Syllable Articulation (PSA), and thus Speech Intelligibility can be achieved at sound pressure level of speech ranging from 60 dBA to 70 dBA (see Figure 8.I.1, Appendix I).
- (b) For speech halls with higher background noise (>20 dBA), the recommended Signal-to-Noise Ratio (SNR) is +15 dBA for children and at least +6 dBA for adults.



Notes:

- (i) The optimum RT for speech is shown here for English and Bangla language. It might be noted that the recommended optimum RT for speech in Bangla ranges from 0.5 s to 0.8 s.
- (ii) The figure shows optimum RT for Western music and English vocals. For local music of Bangladesh, optimum RT might be assumed from its typological similarity to that of Western music.

Figure 8.3.1 Recommended optimum reverberation times for spaces of various uses

3.6.4 Diffusion of Sound

- (a) Diffusion of sound should be achieved in any space, so that certain key acoustical properties, like sound pressure level, reverberation time etc. are the same anywhere in the space.
- (b) There shall not be a difference greater than 6 dBA between sound pressure levels of any two points in the audience area.
- (c) Appropriate room geometry should be chosen to achieve diffusion of sound. Figure 8.E.2, Appendix E shows recommended proportion of a space to avoid standing wave, flutter echo etc., which are obstacles to achieve diffusion of sound.

3.7 Speech Privacy

3.7.1 Principle of Speech Privacy between Enclosed Spaces

3.7.1.1 When noise carries information, productivity and noise are related inversely. When noise does not carry information, it can be annoying, counterproductive or can be useful as a masking sound, depending upon its frequency, intensity level and constancy.

3.7.1.2 The degree of speech privacy in a space is a function of following two factors:

- (a) The degree of sound isolation provided by the barriers between rooms
- (b) The ambient sound level in the receiving room

3.7.1.3 In case of an airtight barrier between two rooms, the sound intensity level of the source room (1) and the receiving room (2) are related as,

$$IL_2 = IL_1 - NR$$

where, NR is reduction, IL_2 and IL_1 are sound intensity levels in the receiving and source room respectively.

3.7.1.4 Transmitted noise level IL_2 is not annoying to a majority of adults, if a properly designed background sound is a maximum 2 dBA less than IL_2 . For example, a transmitted noise IL_2 of 40 dBA in a room with a background sound of at least 38 dBA will not cause annoyance to most people.

3.7.1.5 The upper intensity level of usable background masking sound is usually taken as about 50 dBA; any higher intensity level itself will cause annoyance.

3.7.2 Sound Isolation Descriptor

3.7.2.1 For speech sound, a descriptive scale is shown in Table 8.3.6

3.7.2.2 Relation between barrier STC and hearing condition on receiving side with background noise level at NC-25 is shown in Table 8.3.7

Table 8.3.6: Relative Quality of Sound Isolation

Ranking	Descriptor	Hearing Condition ^a
6	Total privacy	Shouting barely audible.
5	Excellent	Normal voice levels not audible. Raised voices barely audible but not intelligible.
4	Very good	Normal voice levels barely audible. Raised voices audible but largely unintelligible.
3	Good	Normal voice levels audible but generally unintelligible. Raised voices partially intelligible.
2	Fair	Normal voice levels audible and intelligible some of the time. Raised voices generally intelligible.
1	Poor	Normal voice levels audible and intelligible most of the time.
0	None	Normal voice levels always intelligible.

^a Hearing condition in the presence of ambient noise, if any.

Table 8.3.7: Barrier STC and Hearing Condition on Receiving Side with Background Noise Level at NC-25

Barrier STC	Hearing Condition	Descriptor and Ranking ^a	Application
25	Normal speech can be understood quite easily and distinctly through the wall.	Poor/1	Space divider
30	Loud speech can be understood fairly well. Normal speech can be heard but not easily understood.	Fair/2	Room divider where concentration is not essential
35	Loud speech can be heard but not easily intelligible. Normal speech can be heard only faintly, if at all.	Very Good/4	Suitable for offices next to quiet spaces

Barrier STC	Hearing Condition	Descriptor and Ranking ^a	Application
42-45	Loud speech can be faintly heard but not understood. Normal speech is inaudible.	Excellent/5	For dividing noisy and quiet areas; party wall between apartments
46-50	Very loud sounds (such as loud singing, brass musical instruments or a radio at full volume) can be heard only faintly or not at all.	Total Privacy/6	Music room, practice room, sound studio, bedrooms adjacent to noisy areas

^a See Table 8.3.6.

3.7.3 Speech Privacy Design for Enclosed Space

3.7.3.1 Figure 8.J.1, Appendix J shows a Speech Privacy Analysis Sheet, which shall be used to determine speech privacy rating number for design of enclosed space.

3.7.3.2 Following factors are involved in speech privacy rating of enclosed-space:

- (a) Space rating of source room (Room No. 1)
 - (i) Speech effort - a measure of loudness of speech
 - (ii) Source room factor - gives the approximate effect of room absorption on the speech level in the source room. The scale in Figure 8.J.1, Appendix J represents average absorption. For live rooms the factor should be raised by 2 points and for dead room the factor should be lowered by 2 points. Factors (a + b) give the approximate source-room voice level.
 - (iii) Privacy allowance-determines the measure of privacy required, such as *Normal Privacy* and *Confidential Privacy*.
- (b) Isolation rating of receiving room (Room No. 2)
 - (i) The STC rating of the barrier (see Tables 8.E.1 and 8.E.2, Appendix E)
 - (ii) Noise reduction factor A_2/S indicates receiving room absorption, that is, the difference between NR and TL , where A_2 is the area of receiving room and S is the area of the barrier between the rooms. Absorption is assumed to be average. For live rooms the factor should be lowered by 2 points and for dead room the factor should be raised by 2 points.
 - (iii) Recommended background noise level in the receiving room. As a reference, Table 8.3.2 might be used.

3.8 Sound Amplification System

3.8.1 Objectives and Design Criteria

3.8.1.1 A well designed sound amplification system should augment the natural transmission of sound from source to listener with adequate loudness and diffusion. It should never be used as a substitute for good building acoustics design, because it rarely overcomes or corrects any serious deficiency; rather, it may amplify and exaggerate the deficiency.

3.8.1.2 An ideal sound amplification system shall give the listener the desired loudness, directivity, intelligibility and other acoustical qualities.

3.8.1.3 Spaces seating less than 500 (approximately, 1400 m³ volume) should not require any sound amplification system if it is properly designed; since, a normal speaking voice can maintain speech level of 55 to 60 dBA in this volume of space.

3.8.1.4 The central type amplification system is preferred, in which a loudspeaker or a cluster of loudspeakers is placed directly above the source of sound to provide desired realism and intelligibility. In case, the ceiling height is low and sound cannot reach all listeners from a central type; a distributed system can be used with a number of loudspeaker each serving a small area with low-level amplification. A distributed system is particularly feasible in areas under the balcony.

3.8.1.5 A careful location of microphone should be chosen to avoid feedback of sound from loudspeaker to the microphone.

3.9 Occupancy A: Residential Buildings

3.9.1 Controlling Noise

Controlling measures shall have to be taken against noise coming from outdoor and indoor sources as specified in Sections 3.4 and 3.5.

3.9.2 Space Layout

- (a) Quiet and noisy quarters shall be grouped and separated horizontally and vertically from each other by rooms (or spaces) not particularly sensitive to noise such as entry, corridor, staircase, wall closets or other built-in building components.
- (b) If a living room in one apartment is located adjacent to a living room in another apartment, adequate sound insulation should be provided in separating wall.
- (c) Bedrooms shall be located in a relatively quiet part of the building.

- (d) Bathrooms must be separated acoustically from living rooms both horizontally and vertically.

If bathroom fixtures are installed along walls which separate living room and bathroom, adequate sound insulation should be provided in separating wall.

- (e) Measures should be taken to avoid transmission of footstep noise through floors.

3.9.3 Sound Insulation Factors

- (a) Separation for Sound Insulation: The sound insulation criteria in residential units are to be based on three grades:

(i) Grade I criteria apply mainly to fully residential, quiet rural and suburban areas and in certain cases to luxury apartment buildings or to dwelling units above the eighth floor of a high-rise building.

(ii) Grade II criteria apply to residential buildings built-in relatively noisy environments typical of urban or suburban areas.

(iii) Grade III criteria express minimal requirements applicable to very noisy locations, such as commercial or business areas (like shop houses with dwelling units on the upper floors) or downtown areas.

(iv) Among the above three categories, Grade II covers the majority of residential constructions and shall therefore be regarded as a basic guide.

(v) In all grades wall constructions and floor-ceiling assemblies between dwelling units shall have STC ratings at least equal to the values given in Tables 8.3.3 and 8.3.4.

(vi) An STC rating of not less than 45 dB is to be provided in walls and floors of residential buildings, between dwelling units of the same building and between a dwelling unit and any space common to two or more dwelling units.

(vii) Table 8.E.2, Appendix E shows STC requirements for different spaces of specific occupancies.

- (b) Reduction of Airborne Noise : In case of air borne noise (between the frequency range 100-31500 Hz), a sound insulation of 50 dB shall be provided in between the living room in one house or flat and rooms/bed rooms in another. The value shall be 35 dB in between different rooms of the same house. (See Appendix E for airborne sound insulation properties of walls, doors and windows).

- (c) Reduction of Airborne Noise Transmitted through the Structure: Exterior walls shall be rigid and massive and have good sound insulation characteristics with as few openings as possible. Windows with acoustic louvers might be used to protect noise intrusion, while allowing ventilation.

Ventilation ducts or air transfer openings (ventilators), where provided, shall be designed to minimize transmission of noise, if necessary, by installing some attenuating devices.

- (d) Construction of sound insulation doors shall be of solid core and heavy construction with all edges sealed up properly. Hollow core wooden doors and light weight construction shall be avoided because these are dimensionally unstable and can warp, destroying the seal along the perimeter of the door.
- (e) Rubber, foam rubber or foamed plastic strips, adjustable or self-aligning stops and gaskets shall be used for sealing the edges of the doors. They shall be so installed that they are slightly compressed between doors and stop when the door is in a closed position. In simple cases the bottom edges shall have a replaceable strip of felt or foam rubber attached to minimize the gap between door and floor.
- (f) Separation between the two faces of the door shall be carried through uninterruptedly from edge to edge in both directions. Damping treatments shall be inserted between individual layers of the doors. Ordinary doors with surface leather padding shall not be used.
- (g) Automatic damped door closers are to be used whenever applicable and economically feasible in order to avoid the annoying sound of doors slamming.
- (h) The difference between the TL of the wall and that of the door shall not exceed 10 dB.
- (i) The floor of a room immediately above the bedroom or a living room shall satisfy the Grade I impact sound insulation.

3.10 Occupancy B: Educational and Occupancy C: Institutional Buildings

3.10.1 Sources of Noise

3.10.1.1 Outdoor Noise: Measures shall be taken in planning and design to control noise from external sources mentioned in Sections 3.4 and 3.5.

3.10.1.2 Indoor Noise:

The following sources of indoor noise shall be taken into consideration:

- (a) Wood and metal workshops, machine shops, technical as well as engineering testing laboratories, other machine rooms, typing areas etc. which produce continuous or intermittent noises of disturbing nature,
- (b) Music rooms,

- (c) Assembly halls, particularly those which are attached to the main building,
- (d) Practical work spaces, gymnasiums and swimming pools,
- (e) School kitchen and dining spaces,
- (f) Entry lobby, foyer, lounge, corridor and other circulation spaces.

3.10.2 Planning and Design Requirements

3.10.2.1 Site Planning: The school building shall be located as far away as possible from the sources of outdoor noise such as busy roads, railways, neighbouring market places or adjacent shopping areas as well as local industrial and small scale manufacturing concerns.

Where the site permits, the building shall be placed back from the street, in order to make use of the noise reducing effect of the increased distance between street line and building line.

If adequate distance between the school/institution building and the noisy traffic route cannot be provided, rooms which do not need windows or windowless walls of classrooms shall face the noisy road.

Car parking areas shall preferably be located in remote parts of the site.

3.10.2.2 Activities and Space Layout: The minimum requirement for sound insulation in educational buildings shall be as specified in Table 8.3.5.

3.10.2.3 Halls and Circulation Areas: The lobby, lounge areas etc. or other circulation spaces and linking corridors shall be separated from teaching areas, lecture galleries or laboratories. No direct window openings shall be placed along the walls of the corridors or circulation areas.

Doors, ventilators and other necessary openings shall be designed with sufficient foam or rubber seals, so that they are noise proof when closed.

3.10.2.4 Noise Reduction within Rooms: Lecture halls of educational institutions (with a seating capacity of more than 100 persons) shall be designed in accordance with the relevant acoustical principles.

Lecture halls with volumes of up to about 550 m³ or for an audience of up to about 150 to 200, shall not require a sound amplification system, if their acoustical design is based on appropriate principles and specifications.

A diagonal seating layout shall preferably be used for rectangular lecture rooms of the capacity mentioned above as it automatically eliminates undesirable parallelism between walls at the podium and effectively utilizes the diverging front walls as sound reflectors.

3.11 Occupancy D: Health Care Buildings

3.11.1 Sources of Disturbing Noise

3.11.1.1 Outdoor Noise: Sources of outdoor noise specified in Sec 3.4 shall be taken into consideration for planning and design. Additionally, health care service facilities like ambulance, medicine and equipment vans, store deliveries, laundry and refuse collection trolleys are also frequent sources of noise. Health care buildings shall be sited away from such sources as far as practicable.

3.11.1.2 Indoor Noise: Indoor noise sources include mechanical and mobile equipment like X-ray and suction machines, drilling equipment etc. Planning and design shall take into account the following sources of noise:

- (a) The handling of sterilizing, as well as metal or glass equipment,
- (b) Wheeled trolleys used for the purpose of carrying foods and medical supplies,
- (c) Mechanical equipment like mechanical and electrical motors, machineries, boilers, pumps, fans, ventilators, transformers, elevators, air-conditioning equipment etc.
- (d) Operational facilities like refrigerators, sterilizers, autoclaves etc. ,
- (e) Patient service facilities including oxygen cylinders or tanks, saline stands, carrier carts and instrument cases, etc.
- (f) Maintenance work of engineering services like plumbing and sanitary fixtures or fittings, hot and cold water and central heating pipes, air-conditioning ducts, ventilation shafts etc., and
- (g) Audible calling systems, radio and television sets.

3.11.2 Planning and Design Requirements

3.11.2.1 Site Planning: Site shall be selected to keep adequate distance from traffic noise from highways, main roads, railroads, airports and noise originating from parking areas. In addition to the requirements of Sec 4.4.3, the following requirements shall be fulfilled:

- (a) In the selection of a site and site planning, consideration shall be given to:
 - (i) Distance from exterior noise,
 - (ii) Effect of high buildings adjacent to the site which can act as noise reflectors, and
 - (iii) Traffic conditions surrounding the site.

- (b) Parking areas might be carefully located at the farthest possible corners of the premises. If enough space is not available to provide facilities for the desired number of vehicles, parking spaces shall be provided in more than one area. Loading platforms and service entries are to be planned in such a manner as to minimize noise in areas requiring silence.
- (c) Closed courts shall preferably be avoided.

3.11.2.2 Activities and Space Layout: The following points might be given due consideration in the planning and design of health care buildings.

- (a) Rooms to be used for board meetings, conferences, counseling and instructional purposes shall be grouped near public zones of the building in such a way that spread of noise can be avoided.
- (b) Long corridors might be avoided, as it may freely spread noise.
- (c) The main kitchen might be housed in a separate building and connected to the wards only by service lifts or a service stair. If this is impracticable, it shall be planned beneath the wards, rather than above them.
- (d) Mechanical plants might preferably be placed in separate buildings.
- (e) Rooms housing equipment, operational facilities and patient service facilities shall be designed for adequate sound insulation.
- (f) Closed courts might be avoided, unless rooms facing the court are air-conditioned with completely sealed and air tight windows.
- (g) The units which are themselves potential sources of noise for example, children's wards and outpatient departments, shall be treated with special care regarding the protection against noise.

3.11.2.3 Noise Reduction in the Sensitive Area: In health care buildings, many sensitive areas such as operation theatres, doctor's consultation rooms, intensive care units and post-operative areas shall be provided with special noise control arrangements.

These rooms shall preferably be isolated in locations (or corners) surrounded by other intermediate zones which ensure protection of the core area from outdoor noise.

A sound reduction of about 45 dBA between the consulting and the waiting rooms shall be provided in order to weaken the transmission of sound.

A lobby like space in between the interconnecting and communicating doors shall be provided.

3.11.2.4 Sound Insulation Factors: The rooms and indoor spaces of a health care building shall be treated with sound absorptive materials. Different STC ratings of walls specified for separate components of buildings shall have to be considered as follows:

- (a) For airborne noise, the average STC rating of wall and floors shall be 50 dB.
- (b) An STC rating of 55 dB shall be required between rooms whose occupants are susceptible to noise.
- (c) In general an average STC of 45 dB is to be provided for corridor walls and for walls between patient rooms.
- (d) All doors shall be fitted with silent closers. Doors to opposite rooms might be positioned in a staggered manner.
- (e) For ward doors, a corresponding STC of 35 dB shall be provided.
- (f) PVC mats, rubber mats or other resilient materials and rubber shod equipment shall be used in utility rooms, ward kitchens and circulation areas as floor coverings.

Other finish materials like rubber tile, cork tile, vinyl tile or linoleum which can also help reduce the impact noise substantially shall be used alternatively.

- (g) Mobile equipment, such as trolleys and bed, oxygen cylinder carriers and stretchers shall be made relatively silent by means of non-friction wheels with rubber tyre.
- (h) Special treatments such as thin nonporous coverings or films over some soft absorbent materials shall be used for good sound absorption when a washable acoustical treatment is desired.
- (i) Door and window curtains or screens, as well as bed sheets etc. shall be used wherever the indoor openings are located to help reduce reverberation in the hard surfaced surroundings. Curtain rails, rings and runners of silent type shall be used so that they generate as little frictional noise as possible.
- (j) Ventilation ducts and conduits shall be laid out in such a way that they do not open an easy by-pass for spreading out any noise from other sources. These conduits and ducts shall be completely sealed around the pipes where they pass through walls and floors.
- (k) Special care shall be taken to reduce noise of plumbing equipment and fixtures. Specially made silencing pipes and flushing fixtures shall be used to reduce the noise of water closet and cisterns in lavatories and toilets.

Ducts carrying waste or water pipes shall be properly lined with sound insulation material to prevent noise from the pipes passing through duct walls into the patients' wards or cabins or the spaces susceptible to noise.

- (l) Wherever available, cisterns shall be used to replace the pressure operated flushing system so that the disturbance becomes less irritating.

3.12 Occupancy I: Assembly

3.12.1 General

Buildings of Occupancy I shall be designed both for transmission of noise through the walls and openings and also for internal acoustics. Public address systems installed in such buildings shall conform to the standards and specifications.

3.12.2 Sources of Noise

3.12.2.1 Outdoor Noise: The following sources of noise shall be taken into account in planning and design:

- (a) Traffic noise (air, road and rail) and noise from other outdoor sources entering through walls, roofs, doors, windows or ventilation openings,
- (b) Noise from any other gathering spaces, public meetings, outdoor activities and crowds, particularly during the time of breaking of shows and performances,
- (c) Noise produced from parking areas.

3.12.2.2 Indoor Noise: The following indoor noise sources shall be taken into account in planning and design:

- (a) Noise from other adjacent halls located within the same building used for similar performance, or for seminar, symposium or general meetings,
- (b) Noise produced from ticket counters, lobby or lounge areas, rehearsal rooms, waiting areas and corridors,
- (c) Noise generated from other ancillary services located within the building, like cafeteria or snack bar, tea shop, post office, bank or the like,
- (d) Noise generated from the mechanical or electrical equipment, air-conditioning plants, ventilation channels and ducts, plumbing and water lines etc.

3.12.3 Planning and Design Requirements

3.12.3.1 Site Planning and Acoustical Requirements: The noise control of auditoria or assembly halls shall begin with sensible site planning following the measures and precautions stated below:

- (a) The auditorium shall be effectively separated from all exterior and interior noise and vibration sources as far as practicable;
- (b) The assembly halls shall be protected from vehicular or air traffic, parking or loading areas, mechanical equipment, electrical rooms or workshops.

The following are the acoustical requirements for good hearing conditions in an auditorium which shall be ensured in planning and design:

- (a) Adequate loudness shall have to be ensured in every part of the auditorium;
- (b) The sound energy shall be uniformly distributed in the hall;
- (c) Optimum reverberation characteristics shall have to be provided;
- (d) The hall shall be free of such acoustical defects as echoes, long delayed reflections, flutter echoes, sound concentrations, distortions, sound shadow and room resonance etc.;
- (e) Noise and vibration shall be excluded or reasonably reduced in every part or the hall room.

3.12.3.2 Activities and Space Layout in Divisible and Multi-purpose Auditoria

- (a) A protective buffer zone of rooms between exterior noise source and auditorium proper shall be designed.
- (b) Rooms in the buffer zone (lobbies, vestibules, circulation areas, restaurants, ticket counters, offices etc.) shall be shut off from the auditorium proper by sound insulation doors.
- (c) The purposes of the subdivided spaces shall be clarified, in order to establish the predictable intensity of the various sound programs.

3.12.3.3 Noise Reduction within Rooms

- (a) There shall not be any use of continuous, unrecognizable and loud background noise.
- (b) The ventilating and air-conditioning system shall be so designed that the noise level created by the system is at least 10 dB below the permissible background noise level specified in noise criteria level.
- (c) In order to protect the hall from external noise the minimum sound reduction value required in an auditorium is 65 dB for a concert hall and 60 dB for a theatre. This reduction shall be provided on all sides.

3.12.3.4 Sound Insulation Factors

- (a) Rooms in the buffer zone (lobbies, vestibules, circulation areas, restaurants, counter and issue desk corners, office etc.) shall have sound absorbing ceilings and carpeted floor. If the rooms are to be used for the purposes of verbal instructions only, a moderate degree of sound insulation (STC 40 to 45 dB) shall be accomplished by the movable partitions.

-
- (b) If audio equipment or loudspeakers are to be used, an acoustically more effective, efficient partition system shall be used, with sound insulation of STC 45 to 50 dB.
 - (c) An insulation of STC 50 to 60 dB shall be provided if any section of the space is selected for the performance of live music.
 - (d) All windows shall have to be eliminated from the main auditorium walls in order to exclude excessive outdoor noises.
 - (e) Suspended ceilings shall accommodate the ventilating, air-conditioning and electrical services above the room.
 - (f) In order to increase the effectiveness of the suspended ceilings the following measures shall be taken :
 - (i) The ceiling membrane shall weigh not less than 25 kg/m²;
 - (ii) The ceiling membrane shall not be too rigid;
 - (iii) Noise transmission through the ceiling shall have to be avoided by the use of a solid, airtight membrane;
 - (iv) Gaps between ceiling and surrounding structure shall be sealed;
 - (v) The air space between ceiling membrane and structural floor shall be increased to a reasonable maximum;
 - (vi) An absorbent blanket is to be used in the air space above the ceiling;
 - (vii) The number of points of suspension from the structural floor above shall be reduced to a minimum;
 - (viii) Hangers made of resilient substance shall be preferable to the rigid ones.
 - (g) In order to improve the airborne or impact sound insulation of a ceiling the following specifications shall be followed:
 - (i) The ceiling membrane shall have a minimum of 25 mm solid cement plaster layer with completely closed, airtight and sealed joints all around;
 - (ii) If further reduction of undesirable noise is desired within a sound insulated room, sound absorptive treatment shall be provided along the underside of the solid ceiling.

3.12.3.5 Masking Noise: The artificial noise produced by electronically created background noise for the purpose of drowning out or masking unwanted noise, shall be provided. The process shall effectively suppress minor intrusions which might interrupt the recipient's privacy.

3.12.3.6 The maximum permissible background noise levels in various occupancies are specified in terms of Balanced Noise Criteria (NCB) curves. Each of the NCB curves is expressed by the sound pressure level values in the important 1200-2400 Hz frequency band. The NCB levels shall be used to specify the desirable lowest limit under which the background noise must not fall. (See Table 8.3.1 and Figure 8.F.1, Appendix F).

Note: The general configuration of the NCB curves is quite similar to the noise rating (NR) curves established by the International Organization for Standardization, used mostly in the European practice.

3.13 Occupancy E: Business and Occupancy F: Mercantile Buildings

3.13.1 General

Buildings of Occupancy E and F shall be planned and designed to minimize noise from external and internal sources.

3.13.2 Sources of Disturbing Noise

3.13.2.1 Outdoor Noise: The following sources of outdoor noise and those specified in Sec 3.4 shall be taken into account in the planning and design of business and mercantile buildings:

- (i) Traffic,
- (ii) Playgrounds,
- (iii) Market places and shopping areas,
- (iv) Crowds grouped around the buildings for business purpose or other.

3.13.2.2 Indoor Noise: The following sources of indoor noise shall be identified for noise attenuation within buildings:

- (a) Mechanical noise, caused by heating, ventilating and air-conditioning systems, elevators, escalators and pneumatic tubes etc. ;
- (b) Noise produced by office equipment or machines such as typewriters, printers, teleprinters, reproduction, tabulating and punching machines etc.;
- (c) Noise produced by mechanical amplifiers, for example in seminar halls, conference rooms or staff training rooms or the like where public address system is used;
- (d) Machine noise generated from slide rooms, projection rooms and from electrical and mechanical machines like generators, transformers, switch rooms and electric substations etc. ;
- (e) Typical office noise created by speech, voices in circulation areas, opening and closing of doors etc. ;
- (f) Plumbing systems, ventilation plants, lift machineries, air-conditioning and cooling systems.

3.13.3 Planning and Design Requirements

3.13.3.1 Site Planning: Rooms susceptible to noise shall be located away from the sources of noise.

3.13.3.2 Activities and Space Layout: Spaces producing noise and those susceptible to noise shall be separated as far as practicable. The effective length of long corridors shall be minimized. Swing doors are to be provided at intervals.

3.13.3.3 Noise Reduction in the Sensitive Areas

(a) Open plan Offices

- (i) The floor area may be carpeted in order to absorb airborne noise and footstep noise. The carpet shall preferably be thick and placed on top of resilient floors.
- (ii) The entire portion of the ceiling shall be treated with sound absorption materials. Such treatment shall be applied to the screens and nearby walls also.
- (iii) A highly sound absorptive ceiling with a sound absorption coefficient of 0.70 shall preferably be used to absorb 70 percent of the sound energy reflecting 30 percent of it.
- (iv) Moderately noisy office equipment (like typewriters, telephones, computers etc.) shall be distributed as uniformly as possible all over the office space.
- (v) Noisy office equipment shall be concentrated into specific areas of the office space. The space shall be treated with maximum amount of sound absorptive material and visually separated from the rest of the office.

(b) General Offices: Sound absorbent ceiling shall be provided in corridors. Hard floor finishes and batten floors in corridors shall be avoided. Floor ducts shall be planned on one side of corridors.

3.13.3.4 Reduction of Noise at Source: The following measures shall be undertaken to reduce noise at source depending on the degree of noise reduction desired.

- (a) The noise from slamming of doors shall be reduced by fitting automatic quiet action type door closers. Continuous soft, resilient strip set into the door frames as well as quiet action door latches shall be used.
- (b) Machines like typewriters, calculators, printers etc. shall be fitted or installed with resilient pads to prevent the floors or tables (on which they stand) from acting as large radiating panels.
- (c) Noises from ventilating systems, from a uniform flow of traffic or from general office activities, shall be considered to generate an artificial masking noise. In open plan offices the provision of a relatively high but acceptable degree of

background noise (from the ventilating or air-conditioning system) shall be provided, in order to mask undesirable office noises created by typewriters, telephones, office machines or loud conversation and to provide a reasonable amount of privacy.

The background noise masking system shall be introduced gradually without disturbing the feeling of the occupants.

The air-conditioning system may be used to generate background masking noise if the noise level from the ceiling fans, ducts etc. can be suitably reduced to generate the desired frequency spectrum.

3.13.3.5 Sound Insulation Factors: The acoustical performance of the partitions dividing rentable office spaces shall not exceed an STC rating of 25 to 30 dB, unless the background noise is so high that it masks the sound coming through the lightweight partition.

If lightweight partitions are employed for subdivision of large spaces into executive cabins and secretarial areas, the following measures shall be taken to increase the insulation factors:

- (a) Sound barriers shall be provided up to above the false ceiling with a noise reduction characteristic that will not be affected by ducts, conduits or other cable lines including electricity and water piping installed in the ceiling space.
- (b) Where construction of light weight partitions is considered essential, a double skin panel shall be preferred.

The panels shall be installed apart from each other either by use of separate framing or by use of elastic discontinuities in the construction. Sound absorbing materials shall be provided in the air cavity between the panels so that more insulation can be assured.

- (c) All apertures, gaps and joints at side walls, floors and ceiling junctions shall be properly sealed.
- (d) A double panel hollow floor construction shall be employed with heavy sound damping materials introduced between the panels for effective reduction of the structure-borne noise transmitted from upper floors to the floors below, particularly when lightweight floors are provided in multi-use spaces.

Lightweight materials having high natural frequencies may resonate or vibrate due to an applied vibratory force, which may be caused by mechanical equipment, road or rail traffic etc. These materials, if used for specific reasons, shall be isolated from the source of noise in order to reduce the amount of vibration transmitted to the building.

- (e) The floor surfaces surrounding the office space may be lined with a carpet of high sound absorption.

- (f) For sound adsorption with floor carpeting, the following characteristics shall be maintained:
 - (i) Fibre type carpet shall not be used, as it has practically no effect on sound absorption;
 - (ii) Hair, hair jute and foam rubber pads shall be used for higher sound absorption than the less permeable rubber coated hair jute, sponge rubber etc.;
 - (iii) To improve sound absorption the loop-pile fabrics with increased pile height (with the density held constant) shall be applied;
 - (iv) The backing shall be more permeable for higher sound absorption.

3.14 Occupancy G: Industrial Buildings

3.14.1 General Noise Levels

In the noise control of industrial buildings the following requirements are to be fulfilled:

- (a) An acceptable acoustical environment for individual workers and machine operators;
- (b) Speech communication among operators to the required degree;
- (c) Protection of other workers or office employees (either close to the noise source or at some other location within the same building);
- (d) Prevention of noise transmission into adjacent buildings or into the surrounding community.

3.14.1.1 Intermittent Noises : Intermittent noise in the form of isolated explosions, and periodic noise related to pressure relief valves, hammering, grinding and sawing operations etc. shall be identified for enforcing controlling measures.

3.14.1.2 Sources of Noise: The following sources of noise in industrial buildings and manufacturing plants shall be identified and investigated to find whether the machines are in smooth operation and producing minimal mechanical noise.

- (a) Fabrication and assembly machines;
- (b) Machines used for material transport and general plant services;
- (c) Noise caused by impact and coupled with resonant response of the structural members, connected to the impacting surfaces;
- (d) High frequency sounds generated from grinders;
- (e) Frictional noise occurring at the time of sawing, grinding or sanding, as well as during the cutting on lathe machines and in brakes or from bearings;

- (f) Noise generated from piping systems and valves;
- (g) High velocity flow of air, steam or other fluids that undergo an abrupt change in pipe diameter which give rise to turbulence and resultant noise, and noise generated by rapid variation in air pressure caused by turbulence from high velocity air, steam or gases;
- (h) Unpleasant noise identified with rotating or reciprocating machines, which is generated due to pressure fluctuation in the fluids inside the machines.

3.14.2 Hearing Damage Risk Criteria

When the sound level at a particular section in a factory or industrial building exceeds the specified level in terms of magnitude and time (as shown in Table 8.3.5), feasible engineering control shall be applied and implemented in order to reduce the sound to the limits shown. Personal hearing protection equipment shall be provided and used if such control fails to reduce sound levels.

3.14.3 Interference with Communication

In industries where the operator has to follow verbal instructions during operation of the machine the background noise shall be reduced to an acceptable level.

Precautionary measures shall be taken so that the noise generated inside may not be the cause of accidents by hindering communication or by masking warning signals.

3.14.4 Requirements for Noise Reduction

3.14.4.1 Noise Reduction by Layout and Location: Considerable noise reduction may be achieved by a sensible architectural layout in noisy industrial buildings following the steps mentioned below:

- (a) Noisy areas shall be separated from spaces requiring silence.
- (b) The office block is to be located in a separate building. If this is not possible, the office space in a factory shall be segregated from the production area as far as practicable.
- (c) The office building shall not have a common wall with the production areas. Where a common wall is unavoidable it should be of heavy construction (not less than 375 mm thick).
- (d) Electrically operated vehicles shall be used as far as practicable, since they eliminate most of the noise normally associated with combustion engines.

3.14.4.2 Noise Reduction at Source: In order to suppress the noise at the source relatively silent machines and equipment shall be installed. Additionally the following provisions shall be adhered to:

- (a) Appropriate type of manufacturing process or working method shall be selected which does not cause disturbing noise. Machine tools and equipment are to be selected carefully in order to attain lower noise levels in the machine shop.
- (b) Maintenance of vibrating and frictional machineries shall be ensured.
- (c) Impact noises in general shall be reduced; soft and resilient materials shall be applied on hard surfaces where impact noise can originate.
- (d) Rubber tyres or similar other materials shall be fixed on the areas or surfaces used for the handling and dropping of materials.
- (e) The area of the radiating surface from which a noise is radiated shall be reduced to a minimum.
- (f) Resilient flooring (carpeting, rubber tile, cork tile, etc.) shall be used adequately to reduce impact transmission onto the floor.
- (g) Flexible mountings, anti-vibration pads, floating floors etc. shall be used to prevent the transmission of vibration and shock from various machines into the building or structure.
- (h) Mechanically rigid connecting paths must be interrupted by resilient materials so that the transmission of vibration and noise is reduced.

3.14.4.3 Isolator Specifications

- (a) Isolators shall be made of resilient materials like steel (in the form of springs), soft rubber and corks.
- (b) Direct contact between the spring and the supporting structure shall be eliminated, in order to reduce transmission of high frequencies by metal springs.
- (c) Rubber or felt pads shall be inserted between the ends of the springs and the surfaces to which they are fixed.
- (d) Felt or cork shall be used under machine bases, as resilient mats or pads.
- (e) If the equipment is massive like drop hammers causing serious impact vibration (in larger manufacturing plants), it shall be mounted on massive blocks of concrete, on its own separate foundation.
- (f) The foundation shall have a weight 3 to 5 times that of the supported machines.
- (g) A sound reduction of 5 to 10 dBA shall have to be realized from the vibration isolation measures.

3.14.4.4 Noise Reduction by Enclosures and Barriers: When the plant is large in which the overall noise level results from many machines, an enclosure shall be provided.

- (a) When only one or two machines are the dominant source of disturbing noise, the noisy equipment shall be isolated in a small area of enclosure.
- (b) The enclosure shall be in the form of close fitting acoustic box around the machines. The box shall be of such character that the operator can continue with his normal work outside the box.
- (c) An enclosure around the offending unit shall be impermeable to air and lined with sound absorbing materials such that the noise generated by machines is reduced substantially.
- (d) When the industrial plant is a large one in which the resultant noise level is produced from a number of machines, enclosures shall be used either for supervisory personnel or operators who are engaged in monitoring the automatic machines. Such barriers may have inspection openings.
 - (i) Enclosures of this type shall ensure noise reduction of at least 30 dBA, and shall be made of sheet metal lined inside with an appropriate insulation material.
 - (ii) Where curtains are used to isolate the noisy equipment in a small area, they shall be of full length i.e. from ceiling to floor and shall be made of fibre glass cloth and lead or leaded vinyl.
- (e) If the size of the machine is large and asks for more working spaces, thus not permitting close fitting enclosures, the machine shall be housed in a separate room or enclosure.
The inside of the enclosure shall be lined with sound absorbing materials in order to reduce the contained noise.
- (f) If after all these measures are taken the noise level still remains above a tolerable degree, the workers shall be provided with earplugs for protection.

3.15 Acoustical Requirements of Special Occupancies

3.15.1 Susceptible Buildings

3.15.1.1 Recording and radio studios

A recording studio shall present optimum acoustical conditions. A differentiation shall be made among the numerous various purposes of studio use.

- (a) Particular attention shall be given to the following requirements:
 - (i) An optimum size and shape of the studio shall be established following the design criteria;
 - (ii) A high degree of diffusion shall be secured;
 - (iii) Ideal reverberation characteristics shall be provided;
 - (iv) Noises and vibration shall be completely eliminated and acoustical defects shall be totally prevented.

- (b) The acoustical treatments shall be uniformly and proportionately distributed over the three pairs of opposite surfaces enclosing the studio.
- (c) Portable acoustic screen and a reverberation chamber shall be provided so that the desired reverberation condition can be achieved.
- (d) Variable absorbers such as hinged or sliding panels, rotatable cylinders, adjustable drapery etc. shall be fixed on wall surfaces and ceiling areas.
- (e) All surfaces shall be carefully checked for echoes, flutter echoes etc.
- (f) Parallel surfaces shall be eliminated or treated with highly absorptive acoustical materials (throughout the frequency range between 63 and 8000 Hz).

3.15.1.2 Research laboratories

- (a) In the selection of site, care shall be taken to ensure that no noise generating installations exist in the vicinity.
- (b) Location of laboratories shall be secluded from the noisy zones within the building.
- (c) A sound insulation of at least 35 dB shall be achieved by means of acoustic partitions where offices are attached to the laboratory.
- (d) Sound absorbing screens shall be used where scientists and researchers are engaged in laboratory activities and desk work simultaneously.
- (e) Transmission of noise through service ducts, pipes, lifts and staircases shall be guarded.
- (f) Double glazed windows shall be provided in the noise sensitive areas. There shall be a minimum gap of 100 mm between the two glasses.

3.15.1.3 Music rooms

The following provisions shall apply to music rooms, including rehearsal rooms, instructional space, practice booth etc.

- (a) Acoustical conditions in practice booths and listening booths shall have a reverberation time of 0.4 to 0.5 second.
- (b) Adequate floor area, room height, room shape and volume must be established to achieve proper reverberation.
- (c) Sound absorbing materials shall be applied sufficiently so that the excessive sound generated by bands or individual instruments can be soaked up.
- (d) Parallelism between opposite surfaces shall be avoided.
- (e) Entire surfaces of at least two adjacent walls and all the ceiling area shall be treated with sound absorbing materials.

3.15.1.4 Libraries

A quiet and peaceful interior shall be maintained inside libraries. The following provisions are to be adhered to in planning and design:

- (a) Screening and sound insulation measures shall be undertaken in and around the reception/issue desk and photocopying facility areas.
- (b) Stack rooms, store rooms and administrative offices shall be planned in such a way that the audiovisual areas are properly isolated from external noises.
- (c) Walls enclosing the library shall have a sound reduction value of not less than 50 dB.
- (d) Fanlights shall be double glazed and non-openable.
- (e) Walls facing the corridors or other noisy areas shall not have fanlights or borrowed lights unless they are double glazed.

3.15.1.5 Law courts and council chambers

- (a) Entrance into court rooms and council chambers (especially from circulation areas and gathering spaces) shall be through baffle lobbies, with two sets of doors fitted with silencers.
- (b) Offices shall be planned around the court rooms or chambers for further protection against outdoor noise and the central rooms shall have a sound insulation value of not less than 50 dB (provided by 225 mm thick brick wall) to insulate against airborne noise in the corridors.
- (c) The court and chamber rooms shall have floors finished with resilient materials.
- (d) Ceiling and upper parts of the walls of lobbies and circulation areas shall have sound absorbing treatments.

3.15.2 Public Address System

3.15.2.1 Design of public address systems shall take care of equipment choice, positioning of the individual elements and other precautions to obtain optimum performance of the system.

3.15.2.2 Passenger terminals and other public places equipped with public address systems shall as far as practicable avoid the use of sound reflecting surfaces like hard walls and floors. Reverberation time shall be reduced as far as possible by using sound absorbing materials on walls and ceilings.

3.15.2.3 Reverberation built-up sound level shall not be relied upon. Direct sound shall preferably be audible in all areas to be covered by the public address system.

3.15.2.4 Sound levels of the public address system in the areas covered shall be adequately high to overcome background noise.

3.16 Related References

Maekawa Z. and Lord P. 1994. Environmental and Architectural Acoustics. E&FN SPON, UK (Table 8.3.2)

Grondzik, W. T., Kwok, A. G., Stein, B and Reynolds, J. S. 2006. Mechanical and Electrical Equipment for Buildings. John Wiley & Sons, New Jersey. (Tables 8.3.3 to 8.3.6)

3.17 List of Related Appendices

Appendix D	NC, NCB and Recommended Criteria for Sound Insulation
Appendix E	STC, Aural Field and Proportion of Space
Appendix F	Activity Flow Diagram: Planning, Design, Assessment and Construction in Building Acoustics
Appendix G	Checklist for Acoustical Planning, Design and Post-occupancy Assessments
Appendix H	Noise Levels and Subjective Evaluation
Appendix I	PSA and Liveliness
Appendix J	Speech Privacy Analysis Sheet
Appendix K	Sound Absorption Coefficients

PART VIII
Chapter 4
Lifts, Escalators and Moving Walks

4.1 General

4.1.1 Purpose

The purpose of this Chapter is to provide minimum standards for regulating and controlling the design, construction, installation, quality of materials, location, operation, maintenance and use of lifts, escalators and moving walks to ensure public safety and welfare.

4.1.2 Scope

4.1.2.1 The provisions of this Chapter shall apply to the erection, installation, alteration, repair, relocation, replacement, addition to, operation and maintenance of lifts, escalators and moving walks.

4.1.2.2 Additions, alterations, repairs and replacement of equipment or systems shall comply with the provisions for new equipment and systems.

4.1.2.3 Where, in any specific case, different sections of the Code specify different materials or other requirements, the most restrictive one shall govern. Where there is a conflict between a general requirement and a specific requirement, the specific requirement shall be applicable.

4.1.2.4 It shall be unlawful to install, extend, alter, repair or maintain lift, escalator or moving walk systems in or adjacent to buildings except in compliance with this Code.

4.1.3 Terminology

This Section provides an alphabetical list of the terms used in this Chapter of the Code. In case of any conflict or contradiction between a definition given in this Section and that in Part 1, the meaning provided in this Section shall govern for interpretation of the provisions of this Chapter.

AUTOMATIC RESCUE DEVICE	A device meant to bring a lift stuck between floors due to loss of power, to the nearest level and open the doors in order to allow trapped passengers to be evacuated. Such a device may use some form of internal auxiliary power source for such purpose, complying with all the safety requirements of a lift during normal run. The speed of travel is usually lower than the normal speed. In the case of manual doors on reaching the level, the device shall allow the door to be opened and in case of power operated doors the device shall automatically open the door.
----------------------------	--

BALUSTER	One of the slender upright supports of a hand rail.
BALUSTRADE	A row of balusters meant for supporting moving hand rails.
BASEMENT STOREY	The lower storey of a building below or partly below the ground level.
BOTTOM CAR CLEARANCE	The clear vertical distance from the pit floor to the lowest structural or mechanical part, equipment or device installed beneath the car platform aprons or guards located within 300 mm, measured horizontally from the sides of the car platform when the car rests on its fully compressed buffers.
BOTTOM CAR RUNBY	The distance between the car buffer striker plate and the striking surface of the car buffer when the car is in level with the bottom terminal landing.
BOTTOM COUNTER WEIGHT RUNBY	The distance between the counter weight buffer striker plate and the striking surface of the counterweight buffer when the car is in level with the top terminal landing.
BUFFER	A device designed to absorb the impact of the falling car or counter weight beyond its normal limit of travel by absorbing and dissipating the kinetic energy of the car or counterweight.
BUFFER, OIL	A buffer using oil as a medium which absorbs and dissipates the kinetic energy of the descending car or counterweight. Oil buffer stroke - The oil displacing movement of the buffer plunger or piston, excluding the travel of the buffer plunger accelerating device.
BUFFER, SPRING	A buffer which stores in a spring the kinetic energy of the descending car or counterweight. <ul style="list-style-type: none"> • Spring buffer load rating - The load required to compress the spring by an amount equal to its stroke. • Spring buffer stroke - The distance, the contact end of the spring can move under a compressive load until the spring is compressed solid.

CALL INDICATOR	A visual and audible device in the car to indicate to the attendant the lift landings from which the calls have been made.
CAR BODY WORK	The enclosing body work of the lift car which comprises the sides and roof, and is built upon the car platform.
CAR DOOR ELECTRIC CONTACT	An electric device, the function of which is to prevent operation of the driving machine by the normal operating device unless the car door is in the closed position.
CAR FRAME	The supporting frame to which the platform of the lift car, its safety gear, guide shoes and suspension ropes are attached.
CAR PLATFORM	The part of the lift car which forms the floor and directly supports the load.
CAR SPEED	See RATED SPEED (LIFT).
COMB PLATE	A pronged plate that forms part of an escalator (or moving walk) landing and engages with the Cleats of the steps (or tread way) at the limits of travel.
CONTROL SYSTEM	The system of equipment by means of which starting, stopping, direction of motion, speed, acceleration, and retardation of the moving member are controlled.
CONTROL, SINGLE-SPEED ALTERNATING CURRENT	A control for a driving machine induction motor which is arranged to run at a single-speed.
CONTROL, TWO-SPEED ALTERNATING CURRENT	A control for a two-speed driving machine induction motor which is arranged to run at two different synchronous speeds either by pole changing of a single motor or by two different armatures.
CONTROL, RHEOSTATIC	A system of control which is accomplished by varying resistance or reactance or both in the armature or field circuit or both, of the driving machine motor.
CONTROL, VARIABLE VOLTAGE MOTOR (GENERATOR FIELD CONTROL)	A system of control which is accomplished by the use of an individual generator for each lift wherein the voltage applied to the driving machine motor is adjusted by varying the strength and direction of the generator field.

CONTROL, ELECTRONIC DEVICES	A system of control which is accomplished by the use of electronic devices for driving the lift motor at variable speed.
CONTROL, ALTERNATING CURRENT VARIABLE VOLTAGE (ACW)	A system of speed control which is accomplished by varying the driving and braking torque by way of voltage variation of the power supply to the driving machine induction motor.
CONTROL, ALTERNATING CURRENT VARIABLE VOLTAGE VARIABLE FREQUENCY (ACVVVF)	A system of speed control which is accomplished by varying the voltage and frequency of the power supply to the driving machine induction motor.
CONTROL, SOLID- STATE D.C. VARIABLE VOLTAGE	A solid-state system of speed control which is accomplished by varying the voltage and direction of the power supply to the armature of driving machine D.C. motor.
COUNTER WEIGHT	A weight or combination of weights to counterbalance the weight of the car and part of the rated load.
DETERMINING ENTRANCE LEVEL	The inside floor level at the entrance to the building.
DEFLECTOR SHEAVE	An idler pulley used to change the direction of a rope lead.
DOOR, CENTRE OPENING SLIDING	A door which slides horizontally and consists of two panels which open from the centre and are so interconnected that they move simultaneously.
DOOR, HINGED	The hinged portion of the lift well enclosure which closes the opening giving access to the landing.
DOOR, MID BAR COLLAPSIBLE	A collapsible door with vertical bars mounted between the normal vertical members.
DOOR, MULTI-PANEL	A door arrangement whereby more than one panel is used such that the panels are connected together and can slide over one another by which means the clear opening can be maximized for a given shaft width. Multi-panels are used in centre opening and two speed sliding doors.

DOOR, SINGLE SLIDE	A single panel door which slides horizontally.
DOOR, TWO SPEED	A two panel door which slides horizontally in the same direction wherein each panel has different operating speed and reaches the ends simultaneously.
DOOR, VERTICAL BI-PARTING	A door or shutter which slides vertically and consists of two panels or sets of panels that move away from each other to open and are so interconnected that they move simultaneously.
DOOR, VERTICAL LIFTING	A single panel door, which slides in the same plane vertically up to open.
DOOR, SWING	A swinging type single panel door which is opened manually and closed by means of a door closer when released.
DOOR CLOSE	A device which automatically closes a manually opened door.
DOOR OPERATOR	A power-operated device for opening and closing doors.
DRIVING MACHINERY	The motorized power unit for driving the lift, escalator or moving walks.
DUMBWAITER	A small lift with a car which moves in guides in a substantially vertical direction and has a net floor area, total inside height and capacity not exceeding 0.9 m ² , 1.25 m and 225 kg respectively, and is exclusively used for carrying materials and no person. It may or may not be provided with fixed or removable shelves.
ELECTRICAL AND MECHANICAL INTERLOCK	A device provided to prevent simultaneous operation of both up and down relays.
ELECTRO-MECHANICAL LOCK	A device which combines in one unit, electrical contact and a mechanical lock jointly used for the landing and/or car doors.
EMERGENCY STOP PUSH OR SWITCH	A push button or switch provided inside the car designed to open the control circuit to cause the lift car to stop during emergency.

ENCLOSED WELL	The lift well having enclosure walls of continuous construction without openings except for doors at landings.
ESCALATOR	A power driven, inclined, continuously moving stairway used for carrying passengers from one level to another.
ESCALATOR LANDING	The portion of the building or structure which is used to receive or discharge passengers into or from an escalator.
ESCALATOR LANDING ZONE	A space extending from a horizontal plane 40 cm below a landing to a plane 40 cm above the landing.
ESCALATOR MACHINE	The mechanism and other equipment in connection therewith used for moving the escalator
FLOOR	The lower surface in a storey on which one normally walks in a building. The general term 'floor', unless otherwise specifically mentioned shall not refer to a 'mezzanine floor'.
FLOOR LEVELING SWITCH	A switch for bringing the car to level at slow speed in case of double speed or variable speed machines.
FLOOR SELECTOR	A mechanism forming a part of the control equipment, in certain automatic lifts, designed to operate controls which cause the lift car to stop at the required landings.
FLOOR STOPPING SWITCH	A switch or combination of switches arranged to bring the car to rest automatically at or near any pre-selected landing.
GEARED MACHINE	A machine in which the power is transmitted to the sheave through a worm or, worm and spur reduction gearing.
GEARLESS MACHINE	A lift machine in which the motive power is transmitted to the driving sheave from the motor without intermediate reduction gearing and has the brake drum mounted directly on the motor shaft.
GOODS LIFT	A lift designed primarily for the transport of goods, but which may carry a lift attendant or other persons necessary for the loading or unloading of goods.

GOVERNOR	A device which automatically actuates safety devices to bring the lift car and/or counter weight to rest in the event the speed of the equipment in the descending direction exceeds a predetermined limit.
GUIDE RAILS	The members used to guide the movement of a lift car or counterweight in a vertical direction.
GUIDE RAILS FIXING	The complete assy. comprising the guide rails bracket and its fastenings.
GUIDE RAILS SHOE	An attachment to the car frame or counterweight for the purpose of guiding the lift car or counter weight frame.
HANDLING CAPACITY	The capacity of the lift system to carry passengers during a five minute peak period, expressed as the percentage of the estimated total population handled.
HOISTING BEAM	A beam, mounted immediately below the machine room ceiling, to which lifting tackle can be fixed for raising or lowering parts of the lift machine.
HOSPITAL LIFT	A lift normally installed in a hospital, nursing home or clinic and designed to accommodate one number bed/stretchers along its depth, with sufficient space all around to carry a minimum of three attendants in addition to the lift operator.
HYDRAULIC LIFT	A lift where the vertical movement of the lift car is done by hydraulic force of a hydraulic fluid. In this type of lift a plunger is attached to the bottom or top of the lift car wherein the plunger moves inside a cylinder by hydraulic force. The hydraulic lift may be direct-plunger-driven type where the cylinder extends into the ground as deep as the lift rises. Hydraulic lifts may also be roller-chain type actuated by a sheave on a vertical hydraulic cylinder, installed beside the lift shaft. Hydraulic lifts may be used for passenger and freight services. The speeds are between 0.125 mps and 1.0 mps. The load capacities are between 1,000 kg and 50,000 kg.
INTERVAL	Average time gap(s) between consecutive lifts leaving the ground floor or passing any specific floor.

LANDING	That portion of a building or structure used for the reception and discharge of passengers or goods or both into and from a lift car, escalator or moving walk.
LANDING CALL PUSH BUTTON (LIFT)	A push button fitted at a lift landing, either for calling the lift car or for actuating the call indicator.
LANDING DOOR (LIFT)	The hinged or sliding portion of a lift well enclosure, controlling access to a lift car at a lift landing.
LANDING PLATE	The portion of the landing immediately above the mechanism at either end of escalator or moving walk and constructed so as to give access to this mechanism in these areas.
LANDING ZONE	A space extending from a horizontal plane 400 mm below a landing to a plane 400 mm above the landing.
LEVELING DEVICE, LIFT CAR	Any mechanism which either automatically or under the control of the operator, moves the car within the leveling zone towards the landing only and automatically stops it at the landing.
LEVELING DEVICE, ONE WAY AUTOMATIC	A device which corrects the car level only in case of under run of the car but will not maintain the level during loading and unloading.
LEVELING DEVICE, TWO-WAY AUTOMATIC MAINTAINING	A device which corrects the car level on both under run and over-run and maintains the level during loading and unloading.
LEVELING DEVICE, TWO WAY AUTOMATIC NON-MAINTAINING	A device which corrects the car level on both under run and over run but will not maintain the level during loading and unloading.
LEVELING ZONE	The limited distance above or below a lift landing within which the leveling device may cause movement of the car towards the landing.
LIFT	A machine designed to transport persons or materials between two or more levels in a vertical or substantially vertical direction by means of a guided car or platform. The lifting force is provided by electric motor or fluid pressure. The word "elevator" is also synonymously used for "lift".

LIFT CAR	The load carrying unit with its floor or platform, car frame and enclosing bodywork.
LIFT LANDING	That portion of a building or structure used for discharge of passengers or goods or both into or from a lift car.
LIFT MACHINE	The part of the lift equipment comprising of electric motor(s) and control gear therewith, reduction gear (if any), brake(s) and winding drum or sheave, by which the lift car is raised or lowered.
LIFT PIT	The space in the lift well below the level of the lowest lift landing served.
LIFT SYSTEM	One or more lift cars serving the same building.
LIFT WELL	The unobstructed space within an enclosure provided for the vertical movement of the lift car(s) and any counter weight(s), including the lift pit and the space for top clearance.
LIFT WELL ENCLOSURE	Any structure which separates the lift well from its surroundings.
LIFTING BEAM	A beam, mounted immediately below the machine room ceiling to which lifting tackle can be fixed for raising parts of the lift machine.
MACHINE ROOM	The compartment allocated to house the lift machine and associated items.
MACHINERY SPACE	The space occupied by the driving machine and control gear of the lift, escalator or moving walk.
MEZZANINE	An intermediate floor between two floors above ground level.
MOVING WALK	A power driven, horizontal or inclined, continuously moving conveyor used for carrying passengers, horizontally or at an incline up to a maximum of 15 degree.
NEWEL	An upright support of the handrail at the landing of escalator/moving walk where the handrail reverses its direction.

OPEN TYPE WELL	A lift well having enclosure walls of wire grille or similar construction.
OPERATION	The method of actuating the control and/or functioning of any lift machine/equipment.
OPERATION, AUTOMATIC	A method of operation in which by a momentary pressure of a button the lift car is set in motion and caused to stop automatically at any required lift landing.
OPERATION, NON- SELECTIVE COLLECTIVE AUTOMATIC	Automatic operation by means of one button in the car for each landing level served and one button at each landing, wherein all stops registered by the momentary actuation of landing or car buttons are made irrespective of the number of buttons actuated or of the sequence in which the buttons are actuated. With this type of operation, the car stops at all landings for which buttons have been actuated making the stops in the order in which the landings are reached after the buttons have been actuated but irrespective of its direction of travel.
OPERATION, SELECTIVE COLLECTIVE AUTOMATIC	Automatic operation by means of one button in the car for each landing level served and by up and down buttons at the landings, wherein all stops registered by the momentary actuation of the car made as defined under non-selective collective automatic operation, but wherein the stops registered by the momentary actuation of the landing buttons are made in the order in which the landings are reached in each direction of travel after the buttons have been actuated. With this type of operation, all 'up' landing calls are answered when the car is travelling in upward direction and all 'down' landing calls are answered when the car is travelling in downward direction, except in case of the uppermost or lowermost calls which are answered as soon as they reached irrespective of the direction of travel of the car.
OPERATION, SINGLE AUTOMATIC	Automatic operation by means of one button in the car for each landing level served and one button at each landing so arranged that if any car or landing button has been actuated, the actuation of any other car or landing operation button will have no effect on the movement of the car until the response to the first button has been completed.

OPERATION, GROUP AUTOMATIC	Automatic operation of two or more non-attendant lifts equipped with power-operated car and landing doors. The operation of the cars is co-ordinated by a supervisory operation system including automatic dispatching means whereby selected cars at designated dispatching points automatically close their doors and proceed on their trips in a regulated manner. Typically, it includes one button in each car for each floor served and up and down buttons at each landing (single buttons at terminal landings). The stops set up by the momentary actuation of the car buttons are made automatically in succession as a car reaches the corresponding landings irrespective of its direction of travel or the sequence in which the buttons are actuated. The stops set up by the momentary actuation of the landing buttons may be accomplished by any lift in the group, and are made automatically by the first available car that approaches the landing in the corresponding direction.
OPERATION, CAR SWITCH	Method of operation by which the movement of lift car is directly under the operation of the attendant by means of a handle.
OPERATION, SIGNAL	Same as collective operation, except that the closing of the door is initiated by the attendant.
OPERATION, DOUBLE BUTTON (CONTINUOUS PRESSURE)	Operation by means of buttons or switches in the car and at the landings any of which may be used to control the movement of the car as long as the button or switch is manually pressed in the actuating position.
OPERATING DEVICE	A car switch, push button or other device employed to actuate the control.
OVERHEAD BEAMS (LIFT)	The members, usually of steel or reinforced concrete, which immediately support the lift equipment at the top of the lift well.
OVERHEAD PULLEY	An idler pulley used to change the direction of rope.
PASSENGER LIFT	A lift designed for the transport of passengers.

POSITION AND/OR DIRECTION INDICATOR	A device which indicates on the lift landing or in the lift car or both, the position of the car in the lift well or the direction or both in which the lift car is travelling.
POWER OPERATED DOOR	A door operated automatically by a device initiated by a momentary pressure on the push button or by operation of the control system.
RATED LOAD	The maximum load which the lift car, escalator or moving walk is designed and installed to carry safely at its rated speed.
RATED SPEED (LIFT)	The speed attained by the lift in the up direction with rated load in the lift car. Also known as CAR SPEED.
RATED SPEED (ESCALATOR)	The speed at which the escalator is designed to operate in the up direction. It is the rate of travel of the steps, measured along the angle of inclination with rated load on the steps or carriage.
RATED SPEED (MOVING WALK)	The speed at which the moving walk is designed to operate in the up direction. It is the rate of travel of the tread way, measured along the angle of inclination with rated load on the tread way.
RETIRING CAM	A device which prevents the landing doors from being unlocked by the lift car unless it stops at a landing.
ROPING MULTIPLE	A system of roping where, in order to obtain a multiplying the factor from the machine to the car, multiple falls of rope are run around sheave on the car or counterweight or both. It includes roping arrangement of 2 to 1, 3 to 1 etc.
SAFETY GEAR	A mechanical device attached to the car frame or the counter weight to stop and hold the car or counter weight to the guides in the event of a free fall. Governor operated safety gears are used to stop the car or counterweight when it travels at a speed exceeding a predetermined speed.
SERVICE LIFT	A lift designed primarily for the transport of goods, but which may carry a lift attendant or other persons necessary for the loading and unloading of goods.

SHEAVE	A rope wheel, the rim of which is grooved to receive the suspension ropes but to which the ropes are not rigidly attached and by means of which power is transmitted from the lift machine to the suspension ropes.
SLACK ROPE SWITCH	Switch provided to open the control circuit in case of slackening of rope(s)
STOREY	The space between the surface of one floor and the surface of the adjacent floor vertically above or below it. The term 'Floor' shall include 'Roof' but will exclude mezzanine floors.
STOREYS FOR SPECIFIC USE	Storeys which are named according to their functions and the specific uses they are put to. For example, a duct storey is one through which service pipes and electrical conduits may be taken.
SUBSIDIARY STOREY	A storey which occurs below the determining entrance level but above the basement storey.
SUSPENSION ROPES (LIFT)	The ropes by which the car and counter-weight are suspended.
TERMINAL SLOW DOWN SWITCH	A switch when actuated shall compulsorily cut off the high speed and switch on the circuitry to run the lift in leveling speed before reaching on terminal landings.
TERMINAL STOPPING SWITCH NORMAL	Switch for cutting all the energizing current in case of car travelling beyond the top bottom landing or a switch cuts off the energizing current so as to bring the car to stop at the top and bottom level.
TERMINAL STOPPING DEVICE FINAL	A device which automatically cause the power to be removed from an electric lift driving machine motor and brake, independent of the functioning of the normal terminal stopping device, the operating device or any emergency terminal stopping device, after the car has passed a terminal landing.
TOP CAR CLEARANCE	The shortest vertical distance between the top of the car crosshead, or between the top of the car where no crosshead is provided, and the nearest part of the overhead structure or any other obstruction when the car floor is level with the top terminal landing.

TOP COUNTERWEIGHT CLEARANCE	The shortest vertical distance between any part of the counterweight structure and the nearest part of the overhead structure or any other obstruction when the car floor is level with the bottom terminal landing.
TOTAL HEADROOM	The vertical distance from the level of the top lift landing to the floor of the machine room.
TRAVEL (LIFT)	The vertical distance between the bottom and top lift landings served by the equipment.
VENT	An opening provided in the roof or the external wall of a space for the purpose of ventilation.

4.1.4 Preliminary Design Particulars

4.1.4.1 All relevant aspects of lift, escalator or moving walk installations shall be properly evaluated during the planning stage of the building in order to design the most effective conveying system.

4.1.4.2 Appropriate steps shall be taken during the planning stage of the building to determine particulars of lift, escalator or moving walk and the necessary provisions to be kept in the building structure so as to meet the requirements of this Code. Discussion shall be carried out, during planning stage, with all concerned parties, viz. building owner, architect, consulting engineer and/or lift/escalator/moving walk manufacturer to determine the extent of necessary provisions to be kept in the building.

4.1.4.3 Minimum amount of information to be collected for lifts during such meetings shall be the following:

- (a) Number, capacity, speed and disposition of the lifts necessary to give adequate lift service in the building
- (b) Layout and sizes of lift well
- (c) Particulars of lift well enclosure, sizes of punches In the lift well enclosure
- (d) Location of lift machine room (above or below), height of lift machine room
- (e) Provision of adequate access to the lift machine room and size of machine room
- (f) Total headroom clearance
- (g) Provision of ventilation of the lift well
- (h) Depth of lift pit

- (i) Loads which the lift will impose on the building structure, and the holes to be left in the machine room floor and cut-outs for wall boxes for push buttons and signals
- (j) Necessity for and type of insulation to minimize the transmission of vibration and noise to other parts of the building
- (k) Requirements for fixing guide brackets to the building structure, hoisting beam for hoisting of lift machine
- (l) Requirements and layout of electrical power feeders for the lift.

4.1.4.4 Minimum amount of information to be collected for the escalators shall be the following :

- (a) Number and size of each escalator
- (b) Angle of escalator
- (c) Arrangement and layout of escalators with dimensions of floor punches required
- (d) Minimum floor to floor height requirement
- (e) Dimensions of top and bottom escalator landings

4.1.4.5 Minimum amount of information to be collected for the moving walks shall be the following:

- (a) Number and size of each moving walk
- (b) Angle of moving walk
- (c) Arrangement and layout of moving walks with dimensions of floor punches required
- (d) Dimensions of top and bottom moving walk landings

4.1.4.6 For the safety considerations of lift installations and effective utilization of lift installations, locations and arrangement of lifts shall be in accordance with Sec 4.3.3.

4.1.4.7 The building plan submitted with the application for seeking permission of installation of lift, escalator or moving walk from the Authority shall include layout of lift, escalator or moving walk properly identified in the drawing along with the detailed particulars as per Appendix L.

4.1.4.8 Specifications for lifts, escalators and moving walks shall include detailed particulars as per Appendix L.

4.1.4.9 For the purpose of effective installation of lifts, escalators or moving walks, working drawings showing the layout of lifts, escalators or moving walks properly identified in the drawing, details of builders works, for example, holes and/or punches in floors or, walls and supports for lifts, escalators or moving walks shall be prepared prior to the finalization of building design drawings.

4.1.4.10 Necessary particulars of electrical requirements of lifts, escalators or moving walks shall be determined early in the planning stage to include it in the electrical provisions of the building.

4.2 Essential Requirements for Lifts

4.2.1 General

4.2.1.1 Lifts shall be provided in buildings more than six storeys or 20 m in height. Installation of lifts shall be carried out in conformity with the "Lift Act" and rules there under, wherever they are in force.

4.2.1.2 Stretcher Facility in Lifts

- (a) When passenger lifts are installed in any building having more than ten storeys or a height of more than 32 m, each floor served by these lifts must have access to at least one lift with a stretcher facility in accordance with Sec 4.2.1.2(b).
- (b) A lift required to have a stretcher facility by Sec 4.2.1.2(a) shall accommodate a raised stretcher with a patient lying on it horizontally by providing a minimum inside platform area 1275 mm wide x 2000 mm long with a minimum clear opening width of 1050 mm, unless otherwise designed to provide an equivalent facility, to allow the entrance and exit of an ambulance stretcher (minimum size 600 mm wide x 2000 mm long) in its horizontal position. These lifts shall be identified by the internationally recognized symbol for emergency medical services.
- (c) In any multi-storied hospital and health care building there shall be at least one hospital lift having stretcher facility in accordance with Sec 4.2.1.2(a).

4.2.1.3 Standby power

- (a) One or more lifts shall be provided with standby power in
 - (i) A building which has more than ten storeys or a height of more than 32 m,
 - (ii) Hospital and health care buildings.

- (b) Standby power shall be provided by an approved self-contained generator set to operate automatically whenever there is a disruption of electrical power supply to the building.
- (c) The operation of the standby power system shall be as follows:
 - (i) Where only one lift is installed, the lift shall transfer to standby power within 60 seconds after failure of normal power.
 - (ii) Where two or more lifts are controlled by a common operating system, all lifts may be transferred to standby power within 60 seconds after failure of normal power, or if the standby power source is of insufficient capacity to operate all lifts at the same time, all lifts shall be transferred to standby power in sequence, shall return to the designated landing and discharge their load. After all lifts have been returned to the designated landing, at least one lift shall remain operable from the standby power.

4.2.1.4 ADA (American Disabilities Act) Approved Type Lift

- (a) At least one of the lifts of any lift bank shall have features as per requirements of ADA accessibility guidelines.
- (b) Accessible lifts shall be on an accessible route and shall comply with the ASME A17.1-1990, safety code for Elevators and Escalators.
- (c) Lift operation shall be automatic. It shall have door safeties as per clause 4.2.3.9. It shall have self-leveling feature as per clause 4.2.3.13.
- (d) Hall call buttons in the lift lobbies and halls shall be centered at 1065 mm above the floor. Such call buttons shall have visual signals to indicate when each call is registered and each call is answered. Call buttons shall be a minimum 19 mm in the smallest dimension. The button designating the up direction shall be on the top.
- (e) A visible and audible signal shall be provided at each hoist way entrance to indicate which car is answering a call. Audible signal shall sound once for the up direction and twice for the down direction or shall have verbal annunciators that say “up” or “down”. visible signals shall have the following features:
 - (i) Hall lantern fixtures shall be mounted so that their centerline is at least 1830 mm above the lobby floor.
 - (ii) Visual elements shall be at least 64 mm in the smallest dimension.
 - (iii) Signals shall be visible from the vicinity of the hall call button. In-car lanterns located in cars, visible from the vicinity of hall call buttons, and conforming to the above requirements, shall be acceptable.

- (f) All lift hoistway entrance shall have raised and Braille floor designations provided on both jambs. The centerline of the characters shall be 1525 mm above finish floor. Such characters shall be 50 mm high. Permanently applied plates are acceptable if they are permanently fixed to the jambs.
- (g) Lift doors shall open and close automatically. They shall be provided with a reopening device that will stop and reopen a car door and hoistway door automatically if the door becomes obstructed by an object or person. The device shall be capable of completing these operations without requiring contact for an obstruction passing through the opening at heights of 125 mm and 735 mm above finish floor. Door reopening devices shall remain effective for at least 20 seconds. After such an interval, doors may close in accordance with the requirements of ASME 17.1.
- (h) The minimum acceptable time from notification that a car is answering a call until the doors of that car start to close shall be calculated from the following equation:

$$T = D / (445 \text{ mm/s})$$

Where,

T = total time in seconds

D = distance in millimeters from a point in the lobby or corridor 1525 mm directly in front of the farthest call button controlling that car to the centerline of its hoistway door. For cars with in-car lanterns, T begins when the lantern is visible from the vicinity of hall call buttons and an audible signal is sounded. The minimum acceptable notification time shall be 5 seconds.

- (i) The minimum time for lift doors to remain fully open in response to a car call shall be 3 seconds.
- (j) The floor area of lift cars shall provide space for wheel-chair users to enter the car, maneuver within reach of controls, and exit from the car. The minimum width and depth of the car shall be 2000 mm and 1291 mm. The clearance between the car platform sill and the edge of any hoistway landing shall be no greater than 32 mm.
- (k) The level of illumination at the car controls, platform, and car threshold and landing sill shall be at least 53.8 lux.

- (l) Lift control panels shall have the following features:
- (i) Buttons: All control buttons shall be at least 19 mm in their smallest dimensions. They shall be raised or flush.
 - (ii) Tactile, Braille, and Visual Control Indicators: All control buttons shall be designated by Braille and by raised standard alphabet characters for letters, Arabic characters for numerals, or standard symbols, and as required in ASME 17.1. The call button for the main entry floor shall be designated by a raised star at left of the floor designation, and as required in ASME 17.1. All raised designations for control buttons shall be placed immediately to the left of the button to which they apply. Applied plates, permanently attached, are an acceptable means to provide raised control designations. Floor buttons shall be provided with visual indicators to show when each call is registered. The visual indicators shall be extinguished when each call is answered.

4.2.1.5 Responsibility of the owner

- (a) It is the responsibility of the owner of the premises where the lift will be installed, to obtain necessary permission from the Authority before the erection of lifts(s) and for the subsequent commissioning and operation of lift (s).
- (b) The owner shall conduct periodic inspection and maintain the installation in safe working condition at all times.
- (c) Conformity with the provisions of this Code does not relieve the owner of his responsibility to satisfy the requirements of any other Act, Regulations or Ordinances that may be in force from time to time.

4.2.1.6 Conformity with Bangladesh electricity act

All electrical work in connection with electrical lifts shall be carried out in accordance with the provisions of the latest Bangladesh Electricity Act and the provisions of any of its bye-laws and regulations, and shall also comply with the requirements of Chapter 1 of Part 8 of this Code.

4.2.1.7 For detailed specifications of lifts, escalators and moving walks reference shall be made to the latest edition of the ANSI/ASME A 17.1 code or the European EN81 code.

4.2.2 Safety Considerations

4.2.2.1 Fire protection

- (a) Necessary provisions shall be kept to prevent spread of fire through the lift well. Adequate measures shall also be taken to reduce the possibility of spread of fire from the machine room into the lift well.
- (b) Lift well enclosures and machine room shall be constructed with fire resistant materials. In case of fire, the lift well enclosure shall not give off harmful gas or fumes.
- (c) Where lift enclosures are fire rated, manually closing doors at the enclosure well shall have a fire rating equal to that of the enclosure well and automatically closing doors shall have a fire rating equal to one-half of that of the enclosure well.

4.2.2.2 Fire switch

When required fire switch shall be provided, the function of which is to enable the fire authority to take over complete control of one or more lifts in an installation by operating with a fireman's key.

4.2.2.3 Fireman's lift

For buildings having height of 15 m or more at least one lift shall meet the requirements of fireman's lift as described below:

- (a) Lift car shall have floor area of not less than 1.44 m². It shall also have a loading capacity of not less than 544 kg (8 persons).
- (b) Lift landing doors shall have minimum fire resistance of two hours.
- (c) Doors shall be of automatic operation for car and landing.
- (d) The lift speed shall be 1.0 m/s or more so as to reach the top floor from the ground (or entrance) floor within 60 seconds.

4.2.2.4 Warning signs

Warning signs against use of the lifts during a fire shall be displayed near every call button for a passenger lift in accordance with Sec 4.2.10.3.

4.2.2.5 Over speed safety

Efficient automatic devices shall be provided and maintained in each lift to stop the car by suitable braking devices and to cutoff power from the motor whenever excessive descending speed is attained.

4.2.2.6 Over travel safety

Efficient automatic devices shall be provided and maintained in each lift to cut off power from the motor if the car over travels either the top or bottom terminal landing.

4.2.2.7 Manual cranking system

There shall have standard cranking system operable from the lift machine room to move the car manually, during a power failure, to the nearest higher or lower landing for evacuation of passengers.

4.2.2.8 Emergency evacuation system

There shall have arrangement for emergency unlocking of the landing and lift door with a special key from any landing for evacuation as well as for maintenance.

4.2.2.9 Protection of rope breakage

Necessary protection shall be taken against breaking of steel rope.

4.2.2.10 Safe working environment

In order to maintain a safe work environment, and to avoid potential hazards, the following shall be provided:

- (a) caution sign shall be installed in the areas listed below where potential hazard exists:
 - (i) Trip hazard in machine room; and
 - (ii) Caution notice against unauthorized use of rescue devices (for example, brake release device).
- (b) Use of hard hats for entry in pit and car top during construction period.
- (c) Warning sign shall be provided on the controller so also to eliminate the possibility of contact with any exposed or concealed power circuit.
- (d) Car top barricade system shall be provided as primary protection against fall, on car top.
- (e) Whenever work is carried out on the lift and lift is not required to be moved on power, notice shall be put on electrical main switch indicating requirement of de-energized condition.
- (f) During lift installation/maintenance, protection against fall shall be provided with suitable barricades for all open landing entrances.

4.2.2.11 Car door safeties

Lift car doors and landing doors shall be provided with necessary safeties as per Sec 4.2.3.9.

4.2.3 Lift Cars

4.2.3.1 Lift cars shall have net maximum inside area for different loading capacities as shown in Table 8. 4.1.

4.2.3.2 Lift car frame shall be of steel construction having sufficient strength to support safely the rated load, the lift car and all requisite accessories.

4.2.3.3 There shall be provisions for elastic isolators between metal parts to ensure low vibration and low noise during car travel.

Table 8.4.1: Maximum inside Net Platform Areas for Various Rated Loads

Rated Load (mass) (kg)	Maximum Available Car Area (see note) (m ²)	Maximum Number of Passengers	Rated Load (mass) (kg)	Maximum Available Car Area (see note) (m ²)	Maximum Number of Passengers
100	0.40	1	975	2.35	14
180	0.50	2	1000	2.40	14
225	0.70	3	1050	2.50	15
300	0.90	4	1125	2.65	16
375	1.10	5	1200	2.80	17
400	1.17	5	1250	2.90	18
450	1.30	6	1275	2.95	18
525	1.45	7	1350	3.10	19
600	1.60	8	1425	3.25	20
630	1.66	9	1500	3.40	22
675	1.75	10	1600	3.56	23
750	1.90	11	1800	3.88	26
800	2.00	11	2100	4.36	30
825	2.05	12	2500	5.00	36
900	2.20	13			

Note: (i) Beyond 2500 kg, add 0.16 m² for each 100 kg extra

(ii) Maximum available car area = (W x D) + Available area near the car door(s) inside the car.

Where, W = Car inside width in metre; D = Car inside depth in metre

4.2.3.4 The car bodywork shall be of sufficient mechanical strength to resist accidental impact by users or goods. The roof, solid or perforated, shall be capable of supporting two persons or a minimum load of 150 kg. Perforations shall be sufficiently close in mesh not exceeding 40 mm to provide reasonable protection against falling articles to any person travelling in the car.

4.2.3.5 The floor shall be a smooth nonslip surface. If carpeting is used, it shall be securely attached, heavy duty, with a tight weave and low profile, installed without padding.

4.2.3.6 A handrail shall be provided on at least one wall of the car, preferably the rear. The rails shall be smooth and the inside surface at least 38 mm clear of the walls at a nominal height of 800 mm from the floor.

4.2.3.7 Height of the entrance to the lift car shall not be less than 2 m.

4.2.3.8 The lift car doors, shall be power operated horizontally sliding type (non-collapsible), opened and closed by automatic means. However, if space is limited, collapsible doors may be installed in case of buildings not exceeding 8 storeys or 26 m in height, but they shall not be power operated. Sliding doors shall be guided at top and bottom. Means shall be provided to prevent all sliding doors from jumping off the tracks and suitable stops shall be provided to prevent the hanger carriage from leaving the end of the track.

4.2.3.9 Lift door safeties

- (a) Car and landing doors shall open and close in full synchronization being mechanically connected to each other.
- (b) Doors closed by automatic means shall be provided with door reopening device(s) which will function to stop and reopen a car door and adjacent landing door in case the car door is obstructed while closing. The reopening device shall also be capable of sensing an object or person in the path of a closing door without requiring contact for activation. Door reopening devices shall remain effective for a period of not less than 20 seconds. The operating mechanism of car door shall not exert a force more than 125 N.
- (c) Car doors shall be equipped with efficient interlocking or other devices so that the door cannot be opened except when the lift car is at the landing, and that the lift car cannot be moved away from the landing until the leading edge of the single slide or double speed door is within 50 mm of the nearest face of the door jamb or the leading edges of the centre opening doors are within 50 mm of contact of each other.

4.2.3.10 Lift car doors, when closed, shall cover the opening fully except in the case of vertical biparting car doors of goods lifts.

4.2.3.11 Where the lift car has solid enclosure and doors, provision shall be made for a fan for adequate ventilation. To permit switching off the power supply to the lift without switching off the fan and light, a separate switch shall be provided for fan and light.

4.2.3.12 Any vision panel in a car door shall be fire resisting and shall be of safety wired glass or similar material. The area between division bars or other supports shall not exceed 0.1 m². The bottom rail of a framed and glazed door shall be not less than 300 mm deep. Any projections on or recesses (including vision panels) in sliding car doors shall be kept to a minimum in order to avoid finger trapping between sliding parts of the door and any fixed part of the structure.

4.2.3.13 The lift car shall be provided with a self-leveling feature that will automatically bring the car to the floor landing within a tolerance of + 13 mm under normal loading and unloading conditions. This self-leveling shall, within its zone, be entirely automatic and independent of the operating device and shall correct the over-travel or under-travel. The car shall also be maintained approximately level with the landing, irrespective of load. Where no self-leveling device is provided, the leveling difference between the car and the landing shall be within + 40 mm.

4.2.3.14 Car operating panels shall be conveniently located on the side near the door so that passengers can register calls as quickly as possible. The centre line of the alarm button and emergency stop switch shall be at a nominal height of 890 mm, and the highest floor button no higher than 1.37 m from the floor. Floor registration buttons, exclusive of border, shall be a minimum of 18 mm in size, raised, flush or recessed. Visual indication shall be provided to show each call registered and extinguished when the call is answered. Depth of flush or recessed buttons when operated shall not exceed 10 mm. Markings shall be adjacent to the controls on a contrasting colour background to the left of the controls; letters or numbers shall be a minimum of 15 mm high and raised or recessed 0.75 mm. Sign plates permanently attached shall be acceptable. Emergency controls shall be grouped together at the bottom of the panel.

4.2.3.15 A suitable battery operated alarm system shall be installed inside the lift car so as to raise an alarm at a convenient place for getting assistance for passengers trapped inside the lift car.

4.2.3.16 A car position indicator shall be provided above the car operating panel or over the opening of each car to show the position of the car in the lift well by illuminated visual indicator corresponding to the landing at which the car is stopped or through which it is passing.

4.2.3.17 In addition, an audible signal shall preferably be installed which shall sound to tell a passenger that the car is stopping at a floor served by the lift. A special button located with emergency controls may be provided, operation of which shall activate an audible signal only for the desired trip.

4.2.3.18 Each lift car shall be fitted with a light and the car shall be kept illuminated during the whole period the lift is available for use.

4.2.3.19 In installations with more than two lifts in a bank, a telephone or other device for two-way communication between each lift car and a convenient point outside the lift well shall preferably be provided. Markings or the international symbol for telephones shall be placed adjacent to the control on a contrasting colour background.

4.2.3.20 Lift well and lift well enclosures

The Lift well shall only be used for housing equipment forming part of the lift installation or for its operation and maintenance. No other equipment or services shall be accommodated therein. For this purpose, the main electric supply line for lift machine shall be deemed to be part of the lift and the electric cable, if laid along the lift well shaft, shall be properly clamped to the wall.

4.2.3.21 The lift well shall not form part of the ventilation system of the building.

4.2.3.22 In multi-story residential buildings, hotels and hospitals, lift well shall be isolated from sleeping rooms (bed rooms) by lobbies or other spaces.

4.2.3.23 Lift well shall not be located above any room, passage or thoroughfare. However, when absolutely necessary, this can only be permissible with the prior approval of the competent authority and in such case the following provisions shall be made:

- (a) The pit shall be sufficiently strong to withstand the impact of the lift car with the rated load or the impact of the counterweight when either of these is descending at the rated speed or at governor tripping speed;
- (b) Spring or oil buffers shall be provided for lift car and counterweight; and
- (c) The car and counterweight shall be provided with a governor operated safety gear.

4.2.3.24 When there are three or fewer lift cars in a building, they may be located within the same lift well enclosure. When there are four lift cars, they shall be divided in such a manner that at least two separate lift well enclosures are provided. When there are more than four lifts, not more than four lift cars may be located within a single lift well enclosure.

4.2.3.25 The lift car and its counterweight shall travel in juxtaposition to each other.

4.2.3.26 Totally enclosed wells

The enclosure of the totally enclosed wells shall be continuous and shall extend on all sides from floor to floor or stair to stair. No openings except for doors at landings and necessary access panels shall be provided. The enclosure shall be of sufficient mechanical strength to support the lift guides at appropriate intervals and to support in true alignment the landing doors with operating mechanisms and locking devices.

4.2.3.27 Open type wells

- (a) When Lift well enclosures are constructed of wire grille or similar material, the mesh opening shall not be greater than 30 mm (except for door at landings). Such enclosures shall be of sufficient strength to resist accidental impact by users of adjoining areas or by materials or vehicles being moved in the vicinity.

- (b) Where the clearance between the inside of an open type lift well enclosure and any moving or movable part of the lift equipment or apparatus is less than 50 mm, the openings in the enclosure material shall not be more than 10 mm. Larger openings up to 30 mm shall be permissible provided it is further protected by square mesh netting with aperture of not greater than 10 mm and wire not smaller than 1 mm in diameter.

4.2.3.28 There shall be no opening in the lift well enclosure for access to the lift well through the space under the counterweight.

4.2.3.29 The inside surfaces of the lift well enclosures facing any car entrance shall form a smooth continuous flush surface devoid of projections or recesses. Where projections or recesses cannot be avoided, the underside of these projections/recesses shall be beveled to an angle of 60 degrees from the horizontal by means of metal plates or other fire resistive materials as shown in Figure 8.4.1.

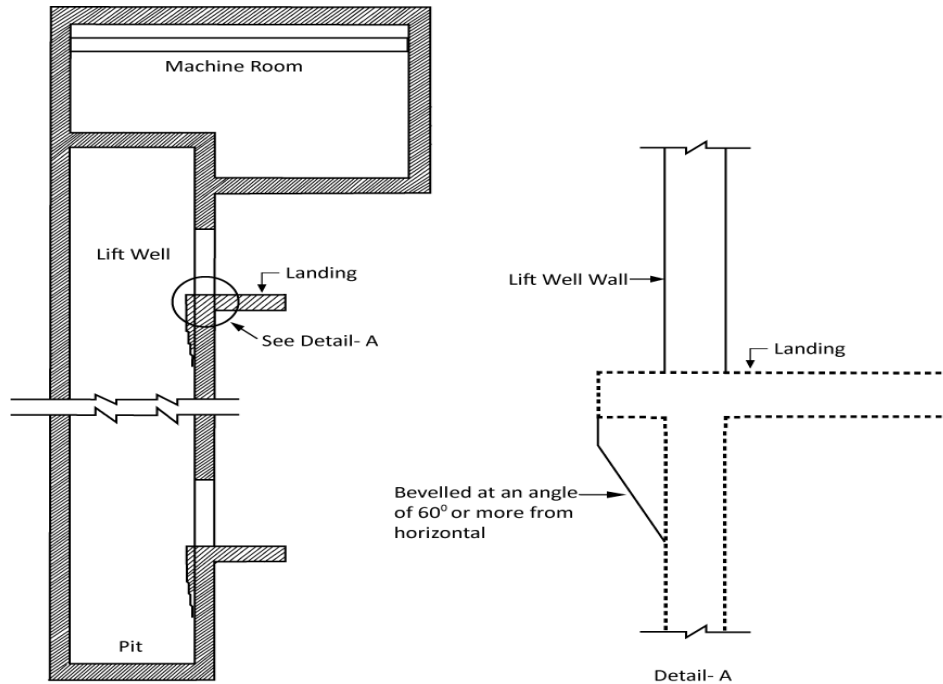


Figure 8.4.1 Beveled projections/recesses

4.2.3.30 Sufficient clearance space shall be provided between the guides for the car and the side walls of the lift well enclosure to allow safe and easy access to the parts of the safety gears for their maintenance and repairs.

4.2.3.31 Maximum clearance between the inner surface of well enclosure on the landing door side and any part of car facing the surface shall be 150 mm except that 230 mm and 200 mm clearance will be permissible when power operated vertically bi-parting landing doors or two speed horizontally sliding doors are installed respectively.

4.2.3.32 Each lift well serving more than two floors shall have vent(s) properly located at the top of the exterior wall. The vents shall be louvered with birds screens. If the well is located in such a way that no exterior wall is available for louvers, vents with connecting noncombustible ducts to an outside wall shall be provided. The area of vent shall not be less than 3.5% of the area of the lift well, provided that a minimum of 0.3 m² per lift is provided. Of the total required vent area not less than one-third shall be permanently open or automatically opened by a damper.

4.2.3.33 Bottom car clearance, passenger and service lift

When the car rests on its fully compressed buffer there shall be a vertical clearance of not less than 600 mm between the pit floor and the buffer striker plate or the **lowest** structural or mechanical part equipment or device installed. The clearance shall be available beneath the whole area of the platform except for:

- (a) Guide shoes or rollers, safety jaw blocks, platform aprons, guards of other equipment located within 300 mm measured horizontally from the sides of the car platform; and
- (b) Compensating sheaves.

Provided that:

- (i) In all the cases, including small cars, a minimum clearance of 600 mm is available over a horizontal area of 800 mm x 500 mm.
- (ii) In all the cases, when the car rests on its fully compressed buffers, there shall be a vertical clearance of not less than 50 mm between any part of the car and any obstruction of device mounted in the pit.

4.2.3.34 Top car clearance, passenger and service lift

The vertical clearance between the car cross-head and the nearest overhead obstruction within 500 mm measured horizontally to the nearest part of the crosshead when the car platform is level with the top landing, shall be not less than the sum of the following;

- (a) The bottom counterweight runby
- (b) The stroke of the counterweight buffer used.

- (c) One-half of the gravity stopping distance based on:
- (i) 115 percent of the rated speed where oil buffers are used and no provision is made to prevent the jump of the car at counterweight buffer engagement; and
 - (ii) Governor tripping speed where spring buffers are used.

Note: The gravity stopping distance based on the gravity retardation from any initial velocity may be calculated according to the following formula

$$S = 51V^2$$

Where,

S = Free fall in mm (gravity stopping distance), and

V = Initial velocity in m/s

- (d) 600 mm.

Where, there is a projection below the ceiling of the well and the projection is more than 500 mm, measured horizontally from the centre line of the cross-head but over the roof of the car, a minimum vertical clearance not less than that calculated above shall also be available between the roof of the car and the projection.

Provided that the vertical clearance between any equipment mounted on top of the car and the nearest overhead obstruction shall be not less than the sum of the three items (a), (b) and (c) as calculated above plus 150 mm

4.2.3.35 Bottom runby for cars and counterweights, passenger and service lift

The bottom runby of cars and counterweights shall be not less than the following:

- (a) Where oil buffers are used 150 mm
- (b) Where spring-buffers are used:
 - (i) 150 mm for variable voltage motor control, electronic devices, ACW control, ACVVVF control and solid state DC variable voltage control as defined in Sec 4.1.3
 - (ii) Not less than the following values for single-speed AC control, two-speed AC control and rheostatic control as defined in Sec 4.1.3.

<u>Rated speed (m/s)</u>	<u>Runby (mm)</u>
Up to 0.125	75
0.125 to 0.25	150
0.25 to 0.50	225
0.50 to 1.0	300

4.2.3.36 Maximum bottom runby, passenger and service lift

In no case the maximum bottom runby shall exceed the following:

- (i) 600 mm for cars
- (ii) 900 mm for counterweights.

4.2.3.37 Top Counterweight Clearances, passenger and service lift

The top counterweight clearance shall be not less than the sum of the following four items:

- (a) the bottom car runby;
- (b) the stroke of the car buffer used;
- (c) 150 mm; and
- (d) one-half the gravity stopping distance based on
 - (i) 115 percent of the rated speed where oil buffers are used and no provision is made to prevent jump of the counterweight at car buffer engagement; and
 - (ii) Governor tripping speed where spring buffers are used.

4.2.3.38 Top car clearance, Goods lift

The top car clearance shall be sufficient to avoid any protruding part fixed on the top of the car coming in direct contact with the ceiling or diverting sheave. The clearance shall not be less than the sum of the following four items:

- (a) The bottom counterweight runby,
- (b) The stroke of the counterweight buffer used,
- (c) The dimensions of the portion of the diverting sheave hanging underneath the ceiling in the lift well
- (d) 150 mm for compensating for gravity stopping distance and future repairs to the rope connections at counter weight and at the car or at the suspension points.

4.2.3.39 Bottom car clearance, goods lift

The bottom car clearance shall be maintained in such a way that the counterweight shall not come in contact with the ceiling or any part hanging underneath the ceiling, when the car completely rests on fully compressed buffers, provided the buffers are spring type mounted on solid concrete or steel bed.

In case of wooden buffers the bottom car clearance shall be maintained in such a way that the total downward travel of the car from the service level of the immediate floor near the pit, shall not be more than the top counterweight clearance, when the wooden buffers are completely crushed.

4.2.3.40 Top counterweight clearance, goods lift

The top clearance for the counterweight can be calculated taking into account the following and shall not be less than the sum of the following three items:

- (a) Car runby,
- (b) Compression of the buffer spring or height of the wooden block used as buffer, and
- (c) 150 mm to compensate for gravity stopping distance for counterweight and any future repairs to rope connections at the counterweight at the car ends or at the suspension points.

4.2.3.41 Runby for cars and counterweights, goods lift

The bottom runby for cars and counterweights shall not be less than 150 mm

4.2.3.42 Maximum bottom runby, goods lift

In no case the maximum bottom runby shall exceed 300 mm.

4.2.3.43 Overhead Height

The overhead height shall not be less than as shown in Table 8.4.2

4.2.3.44 Lift well dimensions

Recommended dimensions of lift well and its entrances are provided in Tables 8.4.3 to 8.4.6. These dimensions are primarily for architects and building planners for planning of lift well.

4.2.4 Landing Doors

4.2.4.1 Every landing, where there is access from the landing to the lift car, shall be fitted with a landing door. Such door shall be fitted with efficient interlocking or other devices so as to ensure that the door cannot be opened except when the lift car is at the landing and that the lift car cannot be moved away from the landing until the door is closed and locked. Where mid bar collapsible doors are used for landing entrance, they shall not be power operated.

4.2.4.2 Where landing doors are manually operated and no indicators are provided, vision panels of similar construction as in Sec 4.2.3.12 shall be provided.

4.2.4.3 No automatic fire door or shutter which operates by means of a fusible link or otherwise due to the action of heat shall be allowed in any landing opening or lift way enclosure of any lift, if such opening gives access to any exit from the building.

4.2.4.4 In case of passenger lifts, solid sliding doors shall preferably be provided for buildings above 6 storeys or 20 m in height. Solid swing doors may also be used where sliding space is not available parallel to the entrance door. Collapsible doors shall not be provided in case of buildings above 8 storeys or 26 m in height.

Table 8.4.2: Minimum Pit Depths, Overhead Heights and Machine Room sizes for Traction Lifts - Overhead Machines

Speed (m/s)	Up to	>0.70	>1.00	>1.50	>1.75	>2.00	>2.50	>3.00
	0.70	≤1.00	≤1.50	≤1.75	≤2.00	≤2.50	≤3.00	≤4.00
(i) Pit Depth, mm	1500	1500	1600	2150	2200	2500	3000	3200
(ii) Overhead Height, mm	4200	4250	4800	4800	5200	5400	-	-
(iii) Machine Room Depth, mm	D + 2000	D + 2000	D + 2000	D + 2500	D + 2500	D + 2500	D + 3000	D + 3000
(iv) Machine Room Width, mm	C + 1000	C + 1000	C + 1200	C + 1200	C + 1500	C + 1500	C + 1800	C + 1800

Notes:

1. C is lift well depth (mm) and D is lift well width (mm).
2. The total overhead height has been calculated on the basis of car height of 2300mm.
3. Dimensions of pit depth and overhead height may differ in practice as per individual manufacturer's design depending upon load, speed and drive. However, the pit depth and overhead height shall be such as to conform to the requirements of bottom clearance and top clearance In accordance with the accepted standard.

Table 8.4.3: Recommended Dimensions of Passenger & Service Lifts and Lift Wells

Capacity		Car Dimensions (mm)		Lift Well Dimensions (mm)		Entrance Size (mm)
Persons	Kg	Width	Depth	Width	Depth	
4	272	1100	700	1900	1300	700 (Min)
6	408	1100	1000	1900	1700	700 (Min)
8	544	1300	1100	1900	1900	800
10	680	1300	1350	1900	2100	800
13	884	2000	1100	2500	1900	900
16	1088	2000	1300	2500	2100	1000
20	1360	2000	1500	2500	2400	1000

Notes :

1. In case of manually operated doors, clear entrance will be reduced by the amount of projection of handle on the landing.
2. All dimensions given above for lifts having centre opening power operated doors with counterweight at rear, are recommended dimensions primarily for architects and building planners. Any variations, mutually agreed between the manufacturer and purchaser, are permitted. However variation in:
 - (i) Car inside dimensions shall be within the maximum area limits specified in accordance with Table 8.4.1
 - (ii) Entrance width on the higher side is permitted.
 - (iii) Entrance width may be reduced up to a maximum of 100 mm subject to a minimum of 700 mm.

Table 8.4.4: Recommended Dimensions of Goods Lifts and Lift Wells

Load (Kg)	Car Dimensions (mm)		Lift Well Dimensions (mm)		Entrance Size (mm)
	Width	Depth	Width	Depth	
500	1100	1200	1900	1500	1100
1000	1400	1800	2300	2100	1400
1500	1700	2000	2600	2300	1700
2000	1700	2500	2600	2800	1700
2500	2000	2500	2900	2800	2000
3000	2000	3000	2900	3300	2000
4000	2500	3000	3400	3300	2500
5000	2500	3600	3400	3900	2500

Notes :

- (i) The width of lift machine room shall be equal to be lift well width subject to a minimum of 2500 mm.
- (ii) Clear entrance width is based on vertical lifting car door and vertical bi-parting landing doors. For collapsible mid-bar doors the clear entrance width will be reduced by 200 mm (maximum 1800 mm).
- (iii) All dimensions given above are recommended dimensions primarily for architects and building planners. Any variations mutually agreed between the manufacturer and the purchaser are permitted. However, variation in car inside dimensions shall be within the maximum area limits in accordance with Table 8.4.1.
- (iv) For dimensions of pit depth and overhead height, consider data shown in Table 8.4.2.

Table 8.4.5: Recommended Dimensions of Hospital Lifts and Lift Wells

Capacity		Car Dimensions (mm)		Lift Well Dimensions (mm)		Entrance Size (mm)
Persons	Kg	Width	Depth	Width	Depth	
12	1020	1000	2400	1800	3000	800
20	1360	1300	2400	2200	3000	1200
26	1768	1600	2400	2400	3000	1200

Notes :

- (i) In the case of manually operated doors, clear entrance will be reduced by the amount of projection of handle on the landing door.
- (ii) Although 15 persons capacity lift is not standard one, this is included to cover lifts of smaller capacity which can be used in small hospitals.
- (iii) All dimensions given above are recommended dimensions primarily for architects and building planners. Any variations mutually agreed between the manufacturer and the purchaser are permitted. However, variation in car inside dimensions shall be within the maximum area limits in accordance with Table 8.4.1.
- (iv) For dimensions of pit depth and overhead height, consider data shown in Table 8.4.2.

Table 8.4.6: Recommended Dimensions of Dumb Waiter and Lift Wells (for speeds up to 0.5 m/s)

Load (Kg)	Car Inside Dimensions (mm)			Lift Well Dimensions (mm)		Entrance Size (mm)
	Width	Depth	Height	Width	Depth	
100	700	700	800	1200	900	700
150	800	800	900	1300	1000	800
200	900	900	1000	1400	1100	900
250	1000	1000	1200	1500	1200	1000

Notes: Entrance width is based on assumption of provision of vertical bi-parting doors (no car door is normally provided).

4.2.5 Guide Rails

4.2.5.1 Guide rails shall be made of high quality steel, straight and of proper thickness. Where the nature of processes carried on in the building gives rise to acid fumes or corrosive substances the steel rails shall be treated for corrosion resistance.

4.2.5.2 Lift car and counterweight guide rails shall be continuous throughout the entire length right from the bottom of the pit floor to the top most floor served plus additional length as may be required for operation of safety against over run. They shall be provided with adequate brackets or equivalent fixing devices of such design and spacing that the rails shall not deflect more than 4 mm under normal operations

4.2.5.3 For passenger and goods lifts having a rated speed of 0.5 m/s or more, the car guide rails shall have working surfaces machined and smooth.

4.2.6 Lift Pits

4.2.6.1 A lift pit shall be provided at the bottom of every lift well. The minimum depth of lift pit shall be as shown in Table 8.4.2.

4.2.6.2 Lift pits shall be of sound construction and shall be maintained in dry and clean condition. Where necessary, provision shall be made for permanent drainage.

4.2.6.3 Lift pits having depth more than 1.6 m shall be provided with a suitable descending arrangement to reach the lift pit.

4.2.6.4 Light points shall be provided in all lift pits for facility of repair and maintenance works.

4.2.6.5 In case of a group of two or more lift wells, arrangements shall be provided to allow inspection of a lift pit through the adjoining one.

4.2.7 Buffers

4.2.7.1 Buffers of spring or oil shall be used for safety. Buffers shall be fitted under the lift car and counterweight directly or on the pit floor with suitable concrete or steel foundation. Oil resistant rubber buffers may be used with lifts having a rated speed not exceeding 0.25 m/s. Lifts having rated speed in excess of 0.25 m/s and up to and including 1.0 m/s, spring or oil buffers shall be used. For lifts having rated speed more than 1.0 m/s, only oil buffers shall be used. Wooden blocks suitably treated may also be used for service lifts for speeds up to 0.5 m/s. Buffers shall be located symmetrically with reference to the vertical centre line of the car/counterweight with a tolerance of 50 mm.

4.2.7.2 The minimum stroke of oil buffers shall be such that the car or the counterweight on striking the buffers at 115 percent of rated speed shall be brought to rest with an average retardation of not more than 10 m/s^2 .

4.2.7.3 When buffers are struck with an initial speed of less than 115 percent of the rated speed, the peak retardation shall not exceed 25 m/s^2 for a duration of more than 0.04 second, with any load in the car ranging from 75 kg to the rated load.

4.2.8 Machine Room and Overhead Structures

4.2.8.1 The lift machine room shall only be used for housing lift machinery, controller and other associated apparatus and equipment. No other services or equipment shall be accommodated therein. If motor-generators for controlling speed of multi-voltage or variable voltage machines, secondary sheaves, pulleys, governors, floor selecting equipment and other associated equipment are installed in an adjoining room, this room shall also be reserved for exclusive use of lift equipment.

4.2.8.2 Lift machine room and other associated equipment rooms shall be fire proof, weather proof and adequately lighted. Means to prevent spread of fire or smoke from machine room into lift well shall be provided. Machine room shall have permanent ventilation opening direct to the open air having a free area not less than 0.1 m^2 per lift. Ambient temperature of machine room shall be maintained between $+5^\circ\text{C}$ and $+40^\circ\text{C}$

4.2.8.3 The height of the machine room shall not be less than 2.30 m throughout under the lifting beam (trolley beam) to allow any portion of equipment to be accessible and removable for repair and replacement. An overhead trolley beam of steel construction of adequate strength shall be provided in the machine room, for movement of equipment during installation.

4.2.8.4 The machine room shall be adequately sized and shall have sufficient floor area required for easy access to all parts of the machines and equipment located therein for purposes of inspection, maintenance or repair. Clearance space of 1 m shall be provided on those sides of control panels where maintenance is required to be carried out while the panel is energized, otherwise 0.5 m clearance space may be provided. For planning purposes the lift machine room size can be as shown In Table 8.4.2

4.2.8.5 The room shall be kept closed, except to those who are concerned with the operation and maintenance of the equipment. When the electrical voltage exceeds 220/230 V dc, a danger notice plate shall be displayed permanently on the outside of the door and on or near the machinery.

4.2.8.6 Machine room floor shall not have holes/punches in it except for necessary small openings for passage of ropes cables etc. If any machine room floor or platform does not extend to the enclosing walls the open sides shall be provided with hand rails or otherwise suitably guarded.

4.2.8.7 All machines, pulleys, over speed governors and similar units shall be securely fixed on the machine room floor.

4.2.8.8 Adequate artificial light shall be provided in the machine room. A 15 amps 3 pin power outlet for hand operated tools and a 5 amps 2 pin electrical outlet for portable hand lamp set shall be provided in the machine room.

4.2.8.9 Access to Machine Room

- (a) The machine room shall be provided with a direct, independent and convenient access. Access to a machine room above a lift well may be either from the roof or by an internal staircase.
- (b) Machine room floor may be provided with a trap door. When access to the machine room is provided through the trap door, the size of the trap door shall not be less than 1.0 m x 1.0 m otherwise it may be 0.5 m x 0.5 m. Trap doors shall be hinged, opening into the machine room, of sound construction, balanced and tightly secured to minimize noise travel. Hand rails shall be provided around trap door opening.
- (c) Where a machine room entrance is less than 1.5 m above or below the adjacent floor or roof surface, a substantial permanently attached ladder may be used.
- (d) Where the machine room entrance is 1.5 m or more above or below the adjacent floor or roof surface, access shall be provided by means of standard stairs.
- (e) Access to a machine room in a basement may be provided from a corridor.
- (f) Access to a machine room via the lift well shall be prohibited.
- (g) Emergency exit shall be provided in case of large machine room having four or more lifts.

4.2.8.10 The space at secondary level in which the overhead pulleys, overspeed governors and similar machinery are housed shall have a clear height of at least 1.2 m. Where practicable, it shall have a substantial platform or floor and be provided with permanent and adequate artificial illumination. Safe and convenient access to secondary level shall be provided. Means of access between a secondary floor and machine room may be a ladder. Hand rails shall be provided at platform and access to floor.

4.2.9 Hall Buttons, Hall Lanterns and Special Signs

4.2.9.1 Hall buttons

- (a) Each landing shall have hall call buttons to register call for lift service for upward or downward movements. The centre line of the hall call buttons shall be at a nominal height of 1 m above the floor.

- (b) Direction buttons, exclusive of borders, shall be a minimum of 18 mm in size, raised, flush or recessed. Visual indication shall be provided to show each call registered and extinguished when the call is answered. Depth of flush or recessed button when operated shall not exceed 10 mm.

4.2.9.2 Hall lantern

- (a) Where lifts are installed in totally enclosed wells, a visual signal shall be provided at each lift well entrance indicating to the prospective passenger the car answering the call and its direction of travel. An audible signal may also be included.
- (b) The visual signal may be in the form of digital lift position indicator or directional indicator. The visual signal for each direction/lift position shall be a minimum of 62 mm in size and visible from the proximity of the hall call buttons.
- (c) The centre line of the fixture shall be located at a minimum of 1.8 m from the floor.

4.2.9.3 Special signs

- (a) Door Jamb Marking: The floor designation shall be provided at each lift well entrance on both sides of jamb visible from within the car and the lift lobby at a height of 1.5 m above the floor. Designations shall be on a contrasting background 50 mm high and raised 0.75 mm.
- (b) Applied plates permanently attached shall be acceptable. In case of a completely enclosed lift well a notice with the word 'Lift' shall be placed outside of each landing door. Electric light shall be provided such that this sign remains visible even if the surroundings are dark.
- (c) A permanent warning sign shall be installed immediately above each hall push button station on each floor reading: IN FIRE EMERGENCY, DO NOT USE LIFT. USE EXIT STAIRS. This sign shall be in letters not less than 12 mm high.

The warning sign may consist of incised, inlaid or embossed letters on a metal, wood, plastic or similar plate securely and permanently attached to the wall, or letters incised or inlaid directly into the surface of the material forming the wall.

4.2.10 Electrical Wiring and Apparatus

4.2.10.1 Construction, installation and maintenance of all electrical supply lines and apparatus in connection with lift installation shall be done with proper protection so that there may be no danger to persons there from. No bare conductor shall be used in any lift car. Installation of electrical wiring shall conform to the provisions of Chapter 1.

4.2.10.2 Electrical circuits for lights and ventilation fans, and supply to 3 pin and 2 pin socket outlets shall be controlled by a separate main switch or circuit breaker, and shall be independent of machinery power supply such that lighting circuits remain alive when power to machinery is interrupted.

4.2.10.3 Suitable cautionary notice shall be affixed near every motor or other apparatus in which energy used is at a voltage exceeding 220 volts.

4.2.10.4 Travelling cable

- (a) Circuits which supply current to the motor shall not be included in any twin or multi-core travelling cable used in connection with the control and safety devices.
- (b) For building 10 storeys (33 m) or less in height, a travelling cable which incorporates conductors for the control circuits shall be separate and distinct from that of lighting and signaling circuits. In case of buildings more than 10 storeys or 33 m in height or where high speed (1.50 m/s or more) lifts are employed, a single travelling cable for lighting and control circuits may be permitted, provided that all conductors are insulated for the maximum voltage in the cables.

4.2.10.5 Supply cables and switches

- (a) Each lift shall be provided with a main switch or circuit breaker of a capacity determined by the lift manufacturer and the incoming supply cable shall terminate in this switch. For a single lift, this switch shall be fixed adjacent to the machine room entrance. In a machine room common to more than one lift, each main switch shall be conveniently situated with respect to the lift it controls. Switches and fuses (which may form part of a distribution switch board) shall be provided for isolating the supply power to machine room.
- (b) Where a supply cable serves more than one lift, a diversity factor may be used for the determination of conductor size. The actual diversity factor to be adopted shall be decided by the lift manufacturer.

4.2.10.6 Earthing

All electrical machinery/equipment viz. electric motor, winding machine, control panel etc. which normally carry mains current shall be properly connected to the earthing system. Similarly all metallic cases, covers of door interlocks, door contacts, call and control buttons, stop buttons, car switches, limit switches, junction boxes and similar electrical fittings which normally carry only the control current shall also be properly connected to the earthing system. All earthing terminal and earthing conductors in this regard shall conform to the requirements of Chapter 1 Part 8.

4.3 Design Considerations

4.3.1 Number of Lifts and Capacity

4.3.1.1 The number of lifts, car capacity and speed of the lift shall be selected to have the most effective lift system. The lift system shall be able to handle adequate number of passengers during peak hours and at the same time Interval and Travel Time shall be within reasonable limits.

4.3.1.2 Average Interval shall not be more than shown in Table 8.4.7. Travel time shall not exceed 150 seconds.

4.3.1.3 The passenger handling capacity (H) of a lift system for different occupancies in terms of the number of passengers to be handled in the building in a five minute peak period shall not be less than that indicated in Table 8.4.7.

4.3.1.4 For the purpose of population estimation, the density of people shall be based on the actual number of occupants, but in no case less than those specified in Table 8.4.8. The occupant load of a mezzanine floor shall be taken into account for working out the population for a particular floor to which the mezzanine floor discharges its loads.

4.3.1.5 Car speed and acceleration

The car speed for the different types of lifts in different occupancies shall normally be as given in Table 8.4.9. A higher or lower speed lift may be used in special cases when conditions warrant use of such lifts. The car acceleration or deceleration shall not be more than 1.2 m/s^2 .

Table 8.4.7: Recommended Interval and 5-minute Handling Capacity for Different Occupancy

Type of Occupancy	Interval (Sec)	5-min. Handling Capacity (H) %	Type of Occupancy	Interval (Sec)	5-min. Handling Capacity (H) %
Office			Apartments (contd.)		
Diversified Tenancy			Middle Income Apartments	60-80	6-8
High Quality	15-29	12	Low Income Apartments	80-120	10-11
Standard Quality	30-39	14	Dormitories, Halls of Residence	60-80	10-11
Single Tenancy			Hospitals		
High Quality	15-24	14	Private Hospital	50-60	12
Standard Quality	25-35	16	General Hospital	60-70	14
Hotels and Motels			Long term Nursing Facilities	60-70	8
High Quality	30-50	12-15	Educational Institutions	40-50	25
Standard Quality	50-70	10-12	Buildings with Assembly Facilities	40-50	15
Apartments			Shops and stores	40-50	5
High Cost Apartments	50-70	5-7			

Table 8.4.8: Occupant Load for Estimation of Population

Type of Occupancy	Population Factor	Type of Occupancy	Population Factor
<u>Office</u>		<u>Apartments (contd.)</u>	
Diversified Tenancy		Middle Income Apartments	2 people per bedroom
High Quality	14-23 m ² net usable area per person ^a	Low Income Apartments	2.5-3 people per bedroom
Standard Quality	10-12 m ² net usable area per person	Dormitories, Halls of Residence	20 m ² net usable area per person
Single Tenancy		<u>Hospitals</u>	
High Quality	12-19 m ² net usable area per person	Private Hospital	3 people per bed
Standard Quality	8-10 m ² net usable area per person	General Hospital	3-4 people per bed
<u>Hotels and Motels</u>		Long term Nursing Facilities	1.75 people per bed
High Quality	1.3 people per room	Educational Institutions	4 m ² per student
Standard Quality	1.7 people per bedroom	<u>Buildings with Assembly Facilities</u>	
Conventions	1.9 people per bedroom	With fixed or movable seats and dance floor	0.60 m ² per person ^b
<u>Apartments</u>		Without seating facilities including dining rooms	1.5 m ² per person ^b
High Cost Apartments	1.5 people per bedroom	Shops and stores	2 m ² of net selling area ^c

Notes :

- (i) Net usable area = gross area less lift shaft and lobby space, mechanical space, columns, toilets, corridor around core, air-conditioning machinery space.
- (ii) Population estimation shall be based on gross area (plinth area or covered area). The gross area shall include, in addition to the main assembly room or space, any occupied connecting room or space in the same storeys or in the storey above and below, where entrance is common to such rooms and spaces and they are available for use by the occupants of the assembly place. No deductions shall be made in the gross area for corridors, closets or other subdivisions, the area shall include all space serving the particular assembly occupancy.
- (iii) Net selling area is area open to the public.

Table 8.4.9: Car Speed for Lift in Different Kinds of Usage

Building Type	Rise (m)	Minimum Car Speed (m/s)	Building Type	Rise (m)	Minimum Car Speed (m/s)
Office Building	0 to 40	2.0	Hospital (contd.)	31 to 40	1.6
	41 to 70	2.5		41 to 55	2.0
	71 to 85	3.6		56 to 75	2.5
	86 to 115	4.0	Above 75	3.6	
	Above 115	5.0	Apartments	0 to 25	0.63
Hotels	0 to 40	2.0		26 to 40	1.0
	41 to 70	2.5		41 to 60	1.6
	71 to 85	3.6	Above 60	2.0	
	86 to 115	4.0	Stores	0 to 30	1.0
	Above 115	5.0		31 to 45	1.6
Hospital	0 to 20	0.63	46 to 60	2.0	
	21 to 30	1.0	Above 60	2.5	

4.3.1.6 Handling capacity and interval

- (a) The handling capacity, for incoming/up-peak passenger, shall be calculated by the following formula:

$$H = \frac{300 \times Q \times N \times 100}{P \times T}$$

Where,

H = passenger handling capacity of the lift system during five minute peak period, expressed as the percentage of the estimated total population handled.

Q = average number of passengers carried in each car per trip,

N = number of lifts in the system,

P = total population to be handled during peak period (it is related to the area for which a particular bank of lift serves)

T = average round trip time in seconds, that is, the average time required by each lift in taking one full load of passengers from ground floor discharging them in various upper floors and coming back to ground floor for taking fresh passengers for the next trip;

The value of Q depends on the dimension of the car. It may be noted that the car is not loaded always to its maximum capacity during each trip and therefore, for calculating T and H the value of Q shall be taken as 80 percent of the maximum capacity of the car.

T is the sum of the time in seconds required in the following process:

- (i) Time for entry of passengers on the ground floor or lowest lift lobby;
 - (ii) Time for exit of the passengers on each floor of discharge;
 - (iii) Door operation time (opening and closing) and car start time on each floor the lift stops, including ground floor;
 - (iv) Acceleration and deceleration periods;
 - (v) Stopping and leveling periods;
 - (vi) Periods of full rated speeds between stops going up and
 - (vii) Periods of full rated speeds between stops going down.
- (a) The average Interval shall be calculated by the following formula:

$$I = \frac{T}{N}$$

Where, I = Interval of availability of lifts on the lowest lift lobby.

4.3.2 Shape and Size of Lifts

4.3.2.1 Careful analysis shall be performed during selection of shape and size of lifts so as to get full advantage of its shape for the most effective use of lifts and building space.

4.3.2.2 The dimensions of the car platform shall be such that the car will not exceed its rated load when packed full. Net inside area of the lift car shall be as per Sec 4.2.3.1.

For the same platform area, a lift having higher width to depth ratio can accommodate more passengers and takes less time for passenger transfer. The width of the car is determined by the width of the entrance and the depth of the car is regulated by the loading.

4.3.3 Location and Arrangement of Lifts

4.3.3.1 A thorough investigation shall be carried out for assessing the most suitable location for lift(s) while planning the building. It shall take into account future expansions, if any.

4.3.3.2 The lifts shall be easily accessible from all entrances to the building. For maximum efficiency, they shall be grouped near the centre of the building. Walking distance from the lift to the farthest office or suite shall not exceed 60 m.

4.3.3.3 Arrangement of lifts

- (a) When more than one lifts are installed in a group, they shall be arranged side by side or in two rows facing each other. Separation of lifts in the group shall be avoided.

- (b) The lift lobby in front of lifts shall be wide enough to allow sufficient space for waiting passengers and proper vision of hall button and hall lanterns. Figures 8.4.2 to 8.4.6 give acceptable arrangements of lifts in a group with acceptable space for waiting passengers. More space shall be allowed in front of the lifts in the main floor than in the upper floors.
- (c) It is preferable that the lift lobby is not used as a thoroughfare, but when absolutely needed the lift lobby shall be wider enough to take into account of the space for people who are moving.

4.3.4 Location of Machine Room

4.3.4.1 The machine room shall, as far as practicable, be placed immediately above the lift well.

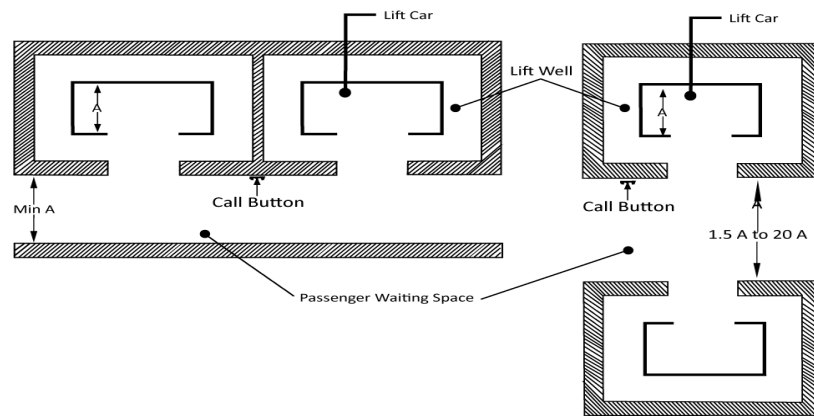


Figure 8.4.2 Two car arrangement

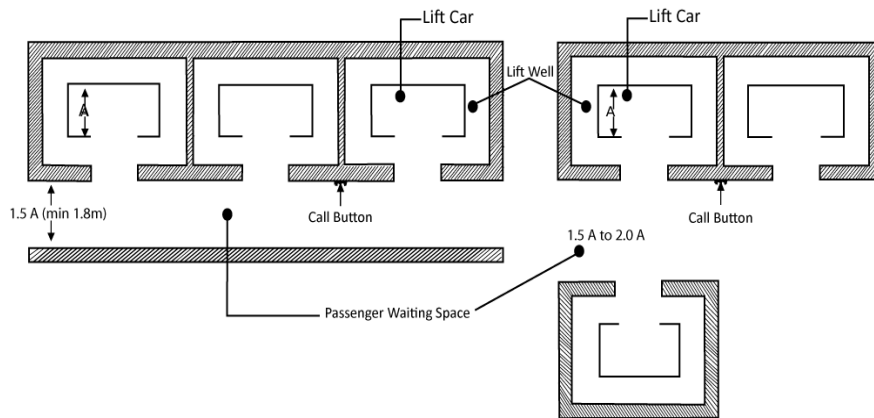


Figure 8.4.3 Three car arrangement

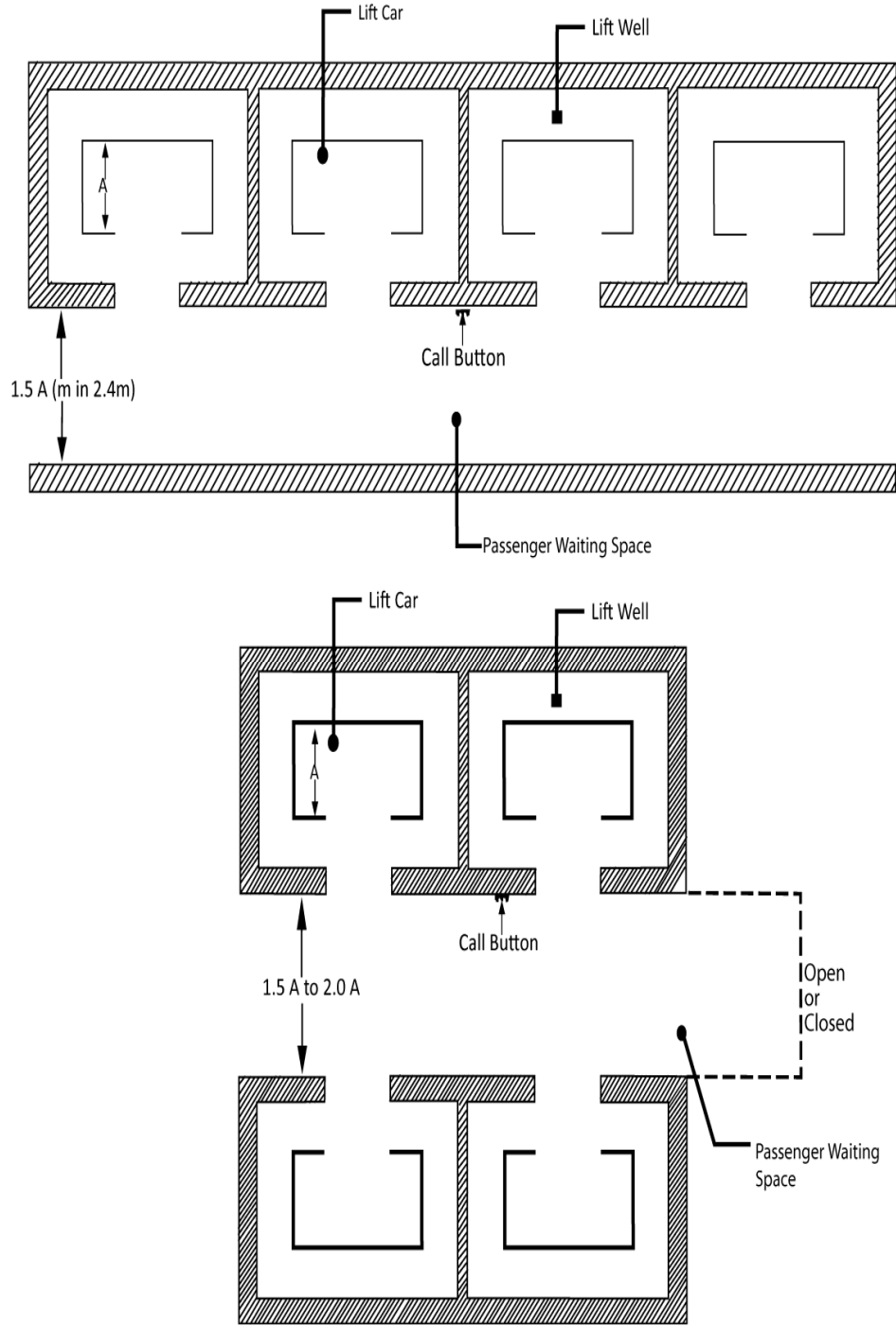


Figure 8.4.4 Four car arrangement

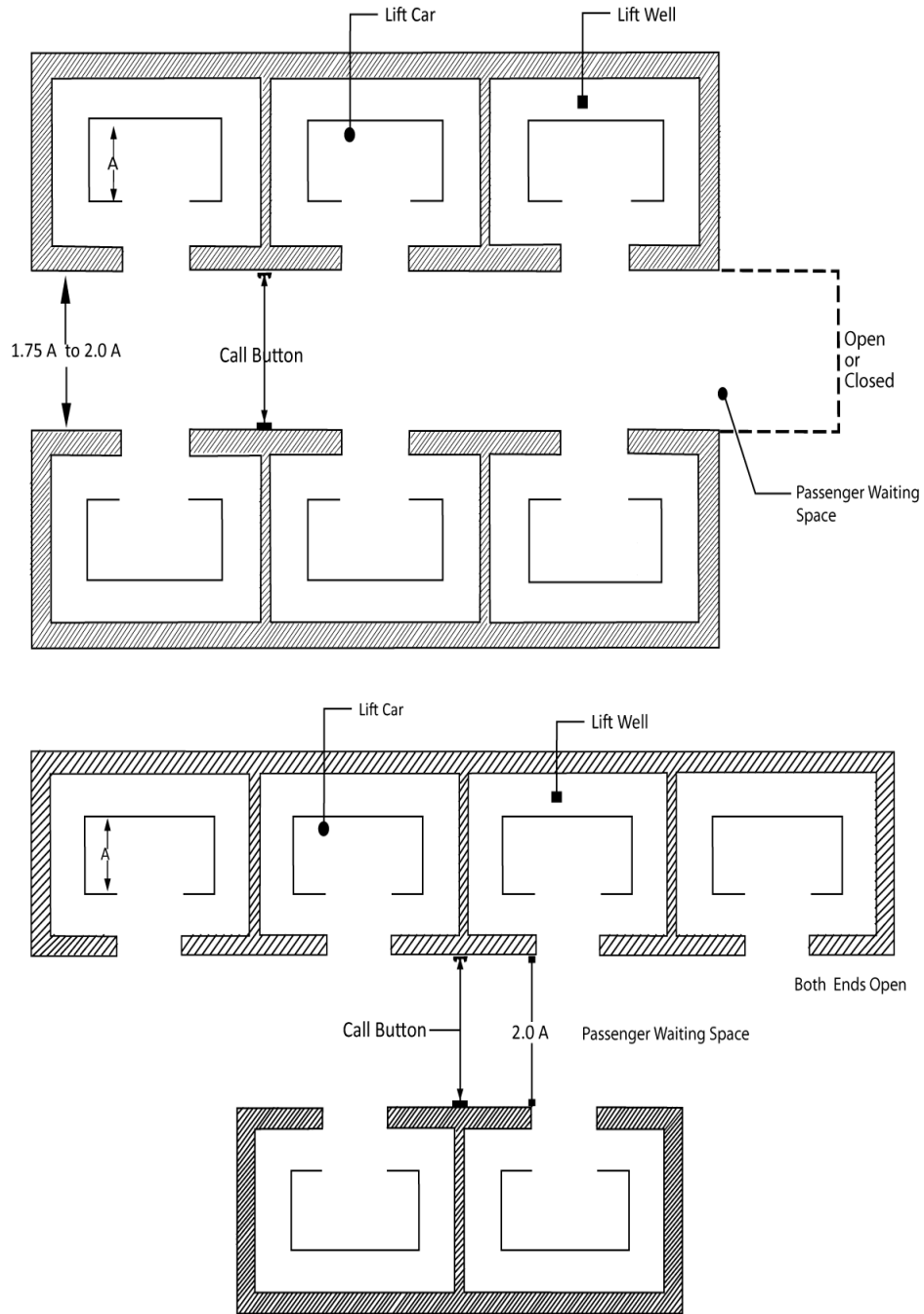


Figure 8.4.5 Six car arrangement

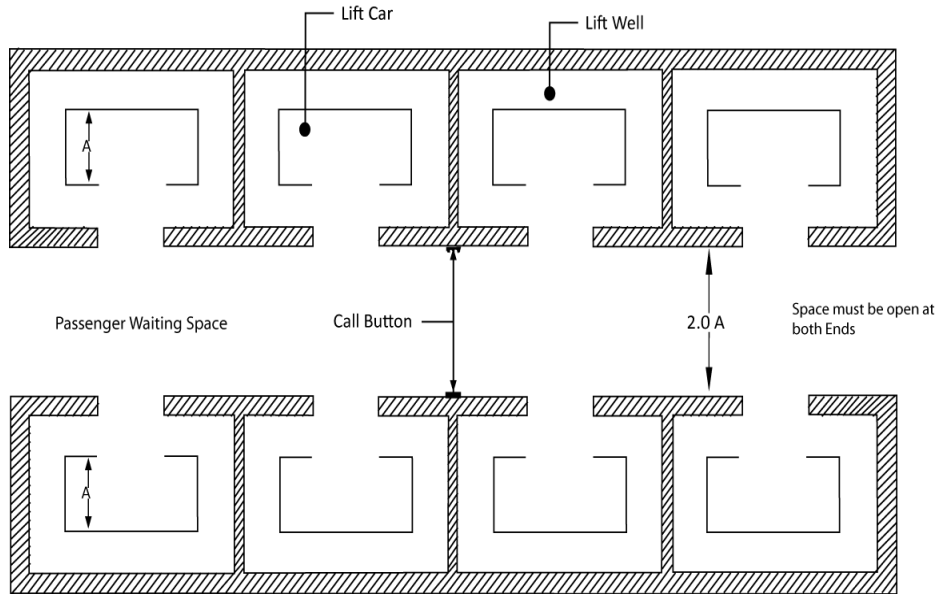


Figure 8.4.6 Eight car arrangement

4.3.4.2 If a machine room on the lift well is impracticable for architectural or other reasons, the machine room may be placed below the lift well or in the basement, keeping adequate safety provisions. If the lift machine room is located in the basement, it shall be separated from the lift well by a separation wall. Alternatively, machine room less lift can be considered for installation.

4.3.4.3 High speed lifts with gearless machine shall, in all cases, have machine room above the lift well.

4.3.4.4 Machine room shall not be located adjacent to or above sleeping rooms (bed rooms) in residential and hotel buildings; and patients' rooms, intensive care rooms and operation theatres of hospital/health care buildings.

4.3.5 Structural Considerations

4.3.5.1 Lift well enclosures, lift pits, machine rooms and machine supports, besides conforming to the essential requirements in Sec 4.2, shall form part of the building construction and comply with the lift manufacturer's drawings.

4.3.5.2 Machine room

Machine room floor shall be strong enough to support the heaviest component of lift machinery and shall be designed to carry a load of not less than 500 kg/m^2 over the whole area and also any load which may be imposed thereon by the equipment used in the machine room or by any reaction from any such equipment during periods of both normal operation and repair.

4.3.5.3 The total load on overhead beams and their supporting structural members shall be assumed to be equal to the dead load of slabs including load of all equipment resting on the beams plus twice the minimum load suspended from the beams.

4.3.5.4 The deflection of the overhead beams under the minimum static load calculated in accordance with Sec 4.3.5.3 shall not exceed $\frac{1}{1500}$ of the span.

4.3.5.5 Beams at all other floor slabs which correspond to the beam at machine room floor shall also be made stronger to take the reaction from the guides when the lift is made to stop consequent to the breaking of the wire ropes or the application of the safety device.

4.3.5.6 Suitable lifting beams may be provided immediately below the machine room ceiling for carrying the tackle to facilitate lifting of any heavy part of a heavy lift. For lower capacity lifts, suitable suspension hooks may be provided.

4.3.5.7 The roof of the machine room shall be strong enough to take up the pulley which could be used for lifting up parts of the lift machinery for inspection and repair.

4.3.5.8 The equivalent dead loads imposed upon the building by the lift installations shall be shown on the lift manufacturer's drawing so that the architect/engineer may make provisions accordingly.

4.3.6 Control System

4.3.6.1 The control of operation of the lift system, leveling, door opening and closing, response to hall calls etc. shall be fully automatic. All control equipment shall be efficient and fail-safe.

4.3.6.2 The control system shall be capable of accelerating the car smoothly to full running speed and stopping the lift with smooth retardation.

4.3.6.3 Variation in speed of the lift between no load and full load conditions shall not be more than plus or minus five percent. The control system shall be capable of correcting any tendency to over speed or under speed. The control system shall have safety device(s) to stop the lift car if its running speed exceeds its rated speed by ten percent.

4.3.6.4 It shall have facility to level or re-level the lift car within ± 13 mm. The leveling system shall be fully automatic and shall correct for over travel or under travel and rope stretch. The car stopping and leveling system shall be unaffected by external influences like variation in load, temperature, rope elongation etc.

4.3.6.5 Closing and opening of car doors and landing doors shall be fully automatic and shall operate in full synchronization with one another. Door opening and closing operations shall be so controlled as to ensure proper safety of passengers.

4.3.6.6 Door opening and closing time and door hold open time shall be automatically controlled to get minimum transfer time in any landing. For larger installations, transfer times shall be independently adjustable to suit the requirements of the building as well as the characteristics of the traffic.

4.3.6.7 Independent door closing push button shall be provided in the lift car to allow instant door closing. Similarly door opening push button shall be provided in the lift car to reverse the closing motion of the doors or hold them open.

4.3.6.8 When there are conditions that particularly affect the safety of passengers, the closing of doors shall only be effective by the continuous pressure of push buttons in the lift car or landings.

4.3.6.9 Each lift shall have key operated switch to transfer from normal passenger control to a car preference control. During car preference control the operation of the lift shall be from the car only and the doors shall remain open until a car call is registered for a floor designation. All landing calls shall be bypassed and car position indicators on the landings for this lift shall not be illuminated.

4.3.6.10 Provisions shall be made in the control system to take any car out of service still maintaining the controlled operation of the remaining cars of a group of cars required for passenger traffic. It is essential that such provision shall not stop the fireman's control from being operative in the event of the lift being designated as a fireman's lift.

4.3.6.11 When required, fire switch shall be provided in the control system as per Sec 4.2.2.2.

4.4 Escalators

4.4.1 General

4.4.1.1 Escalators shall be located in the main line of circulation and in such a way that most persons entering the building can see it. Care shall be taken to eliminate interference to the traffic movement.

4.4.1.2 Escalators shall discharge into an open area with no turns or choice of direction necessary. Ample space for people must be provided at the entry and exit landings of an escalator, space between the newel and the nearest obstruction in front of the escalator shall be a minimum of 3 m.

4.4.1.3 If an unloading area is restricted, such restrictions as doors or gates shall be interlocked with the escalator to insure that the restriction is removed before the escalator can be run.

4.4.1.4 The escalator shall have provision to run in both upward and downward directions. However it shall not run in one direction for one trip and reversed for the next. Starting, stopping or reversal shall be controlled only by an attendant and with the assurance that no passenger is riding at that time.

4.4.1.5 Minimum head room above the escalator (minimum vertical clearance between the line of step nosing and lowest edge of ceiling opening) shall not be less than 2.3 m.

4.4.1.6 Near the place of escalator installation, one lift with wheel chair facility shall be installed to facilitate vertical movement of disabled persons.

4.4.2 Essential Requirements

4.4.2.1 Angle of incline of the escalator shall not be more than 30° from the horizontal. In particular cases, an angle of incline up to 35° may be permitted for escalators having a vertical rise not more than 6 m.

4.4.2.2 The speed of the escalator, measured along the incline shall not be more than 0.63 m/s for 30° angle of incline and 0.50 m/s for 35° angle of incline.

4.4.2.3 Balustrades

- (a) Escalators shall be provided on each side with solid balustrades. On the step side (interior panel), the balustrades shall be smooth and substantially flush except for protective molding parallel to the run of the steps. Vertical moldings that cover joints of panels shall be properly beveled and shall not project more than 6.5 mm. Gaps between interior panels of the balustrade shall not be wider than 4mm.
- (b) The width between balustrades, measured on the incline up to a point 680 mm vertically above the nose line of the steps, shall not be less than the width of the step. It shall not exceed the width of the step by more than 330 mm with a maximum of 165 mm on either side of the escalator.
- (c) There shall be no abrupt changes in the width between the balustrades on the two sides of the escalator. Where a change in width is unavoidable, such change shall not exceed 8 percent of the greater width. In changing the direction of the balustrades resulting from a reduction in width the maximum allowable angle of change in balustrades shall not exceed 15 degrees from the line of the escalator travel.
- (d) The balustrade interior paneling shall have adequate mechanical strength and rigidity. When a force of 500 N is applied at an angles on gap greater than 4 mm and no permanent deformation.
- (e) The use of glass for balustrade interior panelling is permitted, provided it is splinter free one layer safety (tempered) glass and has sufficient mechanical strength and rigidity. The thickness of the glass shall not be less than 6 mm.

4.4.2.4 The clearance on either side of the steps between the steps and the adjacent skirt guard shall not be more than 5 mm and the sum of the clearances on both sides shall not be more than 6 mm.

4.4.2.5 Where the intersection of the outside balustrade (deck board) and the ceiling or soffit is less than 600 mm from the centre line of the handrail, a solid guard shall be provided in the intersecting angle of the outside balustrade (deck board) and the ceiling or soffit. The vertical face of the guard shall project at least 360 mm horizontally from the apex of the angle.

4.4.2.6 Handrails

- (a) Each balustrade shall be provided with a handrail moving in the same direction and at the same speed as the steps.
- (b) Each moving handrail shall extend at normal handrail height not less than 300 mm beyond the line of points of comb plate teeth at the upper and lower landings.
- (c) Hand or finger guards shall be provided at points where the handrails enter the balustrade.
- (d) The horizontal distance between the centre lines of two handrails, measured on the incline, shall not exceed the width between the balustrades by more than 150 mm, with a maximum of 75 mm on either side of the escalator.

4.4.2.7 Step treads

- (a) The depth of any step tread in the direction of travel shall not be less than 400 mm and the rise between treads shall not be more than 220 mm.
- (b) The maximum clearance between step treads on the horizontal run shall be 4 mm.
- (c) The tread surface of each step shall be slotted in a direction parallel to the travel of the steps. Each slot shall not be more than 6.5 mm wide and not be less than 9.5 mm deep; and the distance from centre to centre of adjoining slots shall not be more than 9.5 mm.
- (d) Safety provision shall be installed in the system to stop the escalator when anything is stuck in the clearance between the step tread and the skirting.

4.4.2.8 Landings

Landings shall be made of anti-slip material.

4.4.2.9 Comb plates

There shall be comb plates at the upper and lower landings of every escalator. The comb plate teeth shall be meshed with and set into the slots of the tread surface. Comb plates shall be adjustable vertically. Safety provision shall be installed in the comb plate assembly so that the safety contact stops the escalator when anything is caught between the comb plate and the step.

4.4.2.10 Trusses

The truss shall be designed to sustain the dead and live loads of the steps and running gear in operation safely. In the event of failure of the track system it shall retain the running gear in its guides.

4.4.2.11 Step wheel tracks

These shall be designed to prevent displacement of steps and running gear if a step chain breaks.

4.4.2.12 Rated load

The escalator shall be selected in such a way that it does not exceed its rated load during operation. The rated load in kilogram on an escalator shall be computed by the following formula:

$$\text{Rated load} = 0.27WA \text{ kg}$$

Where,

W = width between the balustrades, mm ; and

A = horizontal distance between the upper and lower comb plate teeth , (m).

4.4.2.13 Design factor of safety

The factor of safety based on static load shall be at least the following:

(i) Trusses and all structural members including tracks	5
(ii) Driving machine parts:	
Made of steel or bronze	8
Made of cast iron and other materials	10
(iii) Power-transmission members	10
(iv) Step chain composed of cast-steel links thoroughly annealed	20

4.4.2.14 Driving machine, motor and brake

- (a) The driving machine shall be connected to main drive shaft by toothed gearing, a coupling, or a chain.
- (b) An electric motor shall not drive more than one escalator.
- (c) Each escalator shall be provided with an electrically released, mechanically applied brake capable of stopping the up or down travelling escalator with any load up to the rated load. The brake shall be located either on the driving machine or on the main drive shaft. Where a chain is used to connect the driving machine to the main drive shaft, a brake shall be provided on this shaft. It is not required that this brake be of the electrically released type if an electrically released brake is provided on the driving machine.

- (d) The braking system shall have provision to bring the escalator automatically to a smooth stop in the event of failure of electrical power or mechanical parts.
- (e) Speed Governor: A speed governor shall be provided, the operation of which shall automatically shut down the escalator in case of over speed or under speed, and prevent reversal of direction (up or down).
- (f) Adequate illumination shall be provided at all landings, at the comb plates and completely down all stair ways.
- (g) An emergency stop switch shall be located near the comb plate or in some obtrusive location.
- (h) All machinery spaces shall have access doors or panels for inspection and maintenance. These panels shall remain locked to prevent unauthorized access.
- (i) Reasonable ventilation shall be provided in machinery spaces.

4.4.2.15 Escalator capacity

- (a) For normal peak period, the recommended handling capacity for design purposes shall be taken as 3200 to 6400 persons per hour depending upon the width of the escalator.
- (b) The number of persons that may be theoretically carried by the escalator in 1 hour can be calculated as follows :
 - (i) For determination of theoretical capacity it is assumed that one step with an average depth of 0.4 m can carry 1 person for step width of 0.6 m, 1.5 persons for a step width of 0.8 m and two persons for step width of 1 m.
 - (ii) The theoretical capacity = $3600 \times (v \times k)/0.4$

Where,

v = rated speed of escalator in m/s

k = 1, 1.5 or 2 for step width of 0.6 m, 0.8 m and 1 m respectively.

4.5 Moving Walks

4.5.1 Essential Requirements

4.5.1.1 Angle of incline of moving walks shall be no more than 15°. A moving walk may have sloping entrance and exit or level entrance and exit.

4.5.1.2 The operating speeds of moving walk at different inclinations and different entrance and exit conditions shall not be more than those given in Table 8.4.10

Table 8.4.10: Operating Speeds of Moving Walk (Based on 1000 mm Nominal Tread Width)*

Incline of Ramp on Slope	Maximum Speed with Level Entrance and Exit (m/s)	Maximum Speed with Sloping Entrance and Exit (m/s)
0 to 3°	0.9	0.9
Over 3 to 5°	0.9	0.8
Over 5 to 8°	0.9	0.7
Over 8 to 12°	0.7	0.65
Over 12 to 15°	0.7	0.63

* Higher tread width may be allowable on horizontal runs.

4.5.2 Balustrades

- Moving walks shall be provided on each side with solid balustrades. On the tread way side the balustrades shall be smooth and substantially flush.
- The width between balustrades, measured up to a point 680 mm vertically above the tread way, shall not be less than the width of the tread way. It shall not exceed the width of the tread way by more than 330 mm with a maximum of 165 mm on either side of the moving walk.
- There shall be no abrupt changes in width between the balustrades on the two sides of the moving walk. Where a change in width is unavoidable, such change shall not exceed 8 percent of the greater width. In changing the direction of the balustrades resulting from a reduction in width the maximum allowable angle of change in balustrades shall not exceed 15° from line of moving walk travel.

4.5.3 Handrails

4.5.3.1 Each balustrade shall be provided with a handrail moving in the same direction and at the same speed as the tread way. Only one handrail may be allowed in a moving walk when the slope of the walkway does not exceed 3°, operating speed is less than 0.35 m/s or the width is no more than 530 mm.

4.5.3.2 Each moving handrail shall extend at normal handrail height not less than 300 mm beyond the line of points of comb plate teeth at the upper and lower landings.

4.5.3.3 Hand or finger guards shall be provided at the point where the handrails enter the balustrade.

4.5.3.4 The horizontal distance between the centre lines of two handrails shall not exceed the width between the balustrades by more than 150 mm with a maximum of 75 mm on either side of the moving walk.

4.5.4 Tread Way

4.5.4.1 The tread surface of the tread way shall be slotted in a direction parallel to the direction of travel.

4.5.4.2 The clearance on either side of the tread way between the tread way and the adjacent skirt guard shall not be more than 5 mm and the sum of the clearances on both sides shall not be more than 6 mm. Safety provisions shall be kept in the system to stop the moving walk when anything is stuck in the clearance between the tread way and the adjacent skirt guard.

4.5.5 Landings

Landings shall be made of anti-slip material.

4.5.6 Comb Plates

4.5.6.1 There shall be comb plates at the entrance and exit of each moving walk. The comb plate teeth shall be meshed with and set into the slots in the tread surface. Safety provision shall be installed in the comb plate assembly so that the safety contact stops the moving walk when anything is caught between the comb plate and the tread.

4.5.6.2 An emergency stop switch shall be located near the comb plate or at some obtrusive location.

4.5.6.3 Adequate illumination shall be provided at comb plates.

4.6 Energy Conservation

4.6.1 General

Lifts, escalators and moving walks shall be designed and installed for efficient use of energy herein provided.

4.6.2 Equipment and Controls

4.6.2.1 Lift

All lifts shall be equipped with necessary sensors and controls to reduce energy usage. For this purpose following features shall be included in the lift system:

- (a) AC Variable-Voltage and Variable-Frequency (ACVVVF) drives for the car and door shall be used.
- (b) Energy efficient lamps shall be used inside the car and for displays.
- (c) The lifts shall operate in standby mode during off-peak periods.
- (d) The power side of the lift controller and other operating equipment such as car lights, display lights and ventilation fans shall be switched off when the lift has been inactive for more than five minutes.

4.6.2.2 Escalator

All Escalators shall be equipped with necessary sensors and controls to reduce energy usage. For this purpose following features shall be included in the lift system:

- (a) The escalator shall reduce speed and operate at lower speed when there is no passenger on the escalator for a period of a maximum of three (03) minutes.
- (b) The escalator shall shut down when no activity has been detected for a period of a maximum of fifteen (15) minutes.

4.7 Inspection and Certification

4.7.1 All new lifts, escalators and moving walks, after installation, shall be inspected and tested by the Authority before these are put into normal services. These shall not be brought into use unless the Authority is satisfied that the installations have been carried out as per provisions of this Code and tests indicate that all the safety devices operate satisfactorily. It shall be unlawful to operate any lift, escalator or moving walk without a current certificate of inspection issued by the Authority. Certificates shall not be issued when the conveyance is posted as unsafe pursuant to Sec 4.7.7.

4.7.2 All electrical lines, control lines and earthings of lift, escalator and moving walk systems shall be tested to determine whether these have been installed properly to meet the requirements of the machine and as per provisions of Chapter 1.

4.7.3 Testing: Tests shall be carried out to determine the operational and safety conditions of lifts, escalators and moving walks in accordance with the provisions of the sections as under:

4.7.3.1 Lift

Tests shall be conducted to ascertain that

- (a) the motor, brake control equipment and car leveling mechanism function properly,
- (b) the door operation is proper and door locking devices function properly,
- (c) the car raises and lowers rated load,
- (d) the car achieves at least the rated speed,
- (e) the lift motor can be overloaded up to a minimum of 10% above the rated capacity,
- (f) the safety gear stops the car with the rated load in case of over speed and/or over travel etc.,
- (g) the buffers function properly, and
- (h) the safety gear operate and keeps operation of the lift suspended in case of the lift car is loaded above its maximum capacity.

4.7.3.2 Escalator and moving walk

Tests on escalators and moving walks shall be conducted to ascertain that

- (a) the automatic control device functions properly and brings the escalator to a smooth stop in case of failure of any mechanical parts or electrical power,
- (b) the automatic safety protection for over speed, under speed and direction reversal functions properly
- (c) safety devices function properly and stops the escalator or moving walk when anything is caught between the comb plate and the treads or the skirting and the treads.
- (d) the handrail and steps or tread way travel at exactly the same speed.

4.7.4 A lift, escalator or moving walk, in which repair and/or maintenance work has been carried out shall also be put to the relevant tests as provided for in Sec 4.7.3.

4.7.5 After proper testing, the Authority shall issue certificate regarding suitability of the lift, escalator or moving walk for normal or regular service. A lift, escalator or moving walk shall be allowed to work only on issuance of this certificate.

4.7.6 The lift, escalator or moving walk shall be inspected periodically to ensure safety.

4.7.7 When an inspection reveals an unsafe condition and the Authority finds that the unsafe condition endangers human life, the Authority shall cause to be placed on such lift, escalator or moving walk, in a conspicuous place, a notice stating that such conveyance is unsafe. The owner shall see to it that such notice of unsafe condition is legibly maintained where placed by the Authority. The Authority shall also issue an order in writing to the owner requiring repairs or alterations to be made to such conveyance necessary to render it safe and may order the operation thereof discontinued until the repairs or alterations are made or the unsafe conditions are removed. A posted notice of unsafe conditions shall be removed only by the Authority and when satisfied that the unsafe conditions have been corrected.

4.8 Operation and Maintenance

4.8.1 The owner shall be responsible for the safe operation and maintenance of each lift, escalator or moving walk installation and shall cause periodic inspections, tests and maintenance to be made on such conveyances as required in this Section.

4.8.2 The lift, escalator or moving walk shall receive regular cleaning and lubrication of relevant parts, and adjustment and adequate servicing by authorized competent persons at such intervals as the type of equipment and frequency of service demand. In order that the lift, escalator or moving walk installation is maintained at all times in a safe condition, a proper maintenance schedule shall be drawn up in consultation with the machine manufacturer which shall be strictly followed.

4.8.3 In case of lift, periodic examination of wire ropes, components of landing and car doors, door interlocking mechanism, brakes, gears, components of safety gears, guides, rollers, channels etc. shall be carried out as recommended by the manufacturer. In no case shall the interval between such inspections exceed six months.

4.8.4 Grooves of drums, sheaves and pulleys of lifts shall also be examined when rope replacement is made. If necessary, the drums, sheaves or pulleys shall be properly re-machined.

4.8.5 In case of escalators and moving walks, periodic examination of balustrades, handrail, tread way, tread way interconnection, comb plates speed governor, drives, chains, non-reversal device, brakes, gears etc. shall be carried out as recommended by the manufacturer, but in no case the interval shall exceed six months.

4.8.6 Sundry Precautions

4.8.6.1 Adequate precaution shall be taken to guard against any possibility of a lift being operated by unauthorized persons. Precautions shall also be taken to prevent a lift from being operated by any person when it is not intended for use.

4.8.6.2 No person shall remain in the pit while the lift is working. Adequate precautions shall be taken to protect persons working in the pit from accidental contact with the counter weight.

4.8.6.3 While the lift is under examination or repairs, suitable steps shall be taken to ensure that the lift is not operated inadvertently by a person in such a manner as may endanger the safety of persons working in the lift.

4.8.6.4 No such explosive or other inflammable material shall be carried in the lift car as may endanger the safety of persons and property.

4.9 Related Appendix

Appendix L Format for Particulars of Lifts, Escalators and Moving Walks.

PART VIII
Chapter 5
Water Supply

5.1 Purpose and Scope

5.1.1 The purpose of this Chapter of the Code is to provide minimum standards for the design, installation and maintenance of water supply and distribution system within a building and its premises.

5.1.2 The regulations of this Chapter also provide guidelines for water requirements for different classes of buildings according to their occupancy classification.

5.1.3 The provisions stated herein do not cover the requirements of water supply for industrial plants and process, municipal uses, viz. street washing, street hydrant, etc.

5.2 Terminology

This Section provides an alphabetical list of the terms used in and applicable to this Chapter of the Code. In case of any conflict or contradiction between a definition given in this Section and that in Part 1 of the Code, the meaning provided in this Section shall govern the interpretation of the provisions of this Chapter.

ACCESSIBLE	When applied to a fixture, appliance or equipment shall mean having access thereto, but which may require the removal of an access panel or similar obstruction; "readily accessible" shall mean direct access without the necessity of removing any panel, door or similar obstruction.
AIRGAP	The unobstructed vertical distance through the free atmosphere between the lowest opening from any pipe or faucet supplying water to tank, plumbing fixture or other device and the flood level rim of the receptacle.
AVAILABLE HEAD	The head of water available at the point of consideration due to mains' pressure or storage tank or any other source of pressure.
BACK SIPHONAGE	The flowing back of used, contaminated, or polluted water from a plumbing fixture or vessel into a water supply pipe due to a reduced pressure in such a pipe (see BACKFLOW).
BACKFLOW	The flow of water or other liquids, mixtures or substances into the distribution pipes of a potable water supply from any source other than its intended source.

BACKFLOW CONNECTION OR CONDITION	Any arrangement whereby backflow can occur.
BACKFLOW PREVENTER	A device or means to prevent backflow.
BALL COCK	A water supply valve, opened or closed by means of a float or similar device, used to supply water to a tank forming an approved air gap or vacuum breaker and acting as an anti-siphon device. Also known as FLOAT OPERATED VALVE.
BEDPAN WASHER AND STERILIZER	A fixture designed to wash bedpans and to flush the contents into the sanitary drainage system and located adjacent to a water closet or clinical sink. Such fixtures can also be provided for disinfecting utensils by scalding with steam or hot water.
BRANCH	Any part of the piping system other than a riser or main.
BRANCH CONNECTOR	A connector between water main and branch pipes by T, Y, T-Y, double Y, and V branches according to their respective shapes.
BUILDING SUPPLY	The water supply pipe carrying potable water from the water meter or other source of water supply to a building or other point of use or distribution on the lot.
CONTAMINATION	A general term meaning the introduction into the potable water supply of chemicals, wastes or sewage which will render the water unfit for its intended purpose.
CRITICAL LEVEL	The level at which the vacuum breaker may be submerged before backflow occurs. When the critical level is not indicated on the vacuum breaker, the bottom of the device shall be considered as the critical level.
CROSS-CONNECTION	Any physical connection or arrangement between two otherwise separate piping systems, one of which contains potable water and the other either water of unknown or questionable safety or steam, gas, or chemical whereby there may be a flow from one system to the other, the direction of flow depending on the pressure differential between the two systems (See BACKFLOW).

CYLINDER	A cylindrical closed vessel capable of containing water under pressure greater than the atmospheric pressure.
DEVELOPED LENGTH	Length of a pipe along the centerline of the pipe and fittings.
DISTRIBUTION PIPE	Any pipe conveying water from a storage tank/cistern or from a hot water apparatus supplied from a feed cistern under pressure from that cistern.
EFFECTIVE OPENING	The minimum cross-sectional area at the point of water supply discharge measured or expressed in terms of; (i) diameter of a circle, (ii) if the opening is not circular, the diameter of a circle of equivalent cross-sectional area. (also applicable to AIR GAP.)
FAUCET	A valve end of a water pipe by means of which water can be drawn from or held within the pipe.
FEED CISTERN	A storage tank/cistern used for supplying cold water to a hot water apparatus.
FITTING	Anything fitted or fixed in connection with the supply, measurement, control, distribution, utilization or disposal of water. "Water fitting" includes pipes (other than mains), taps, cocks, valves, ferrules, meters, cisterns, baths, water closets, soil pans and other similar apparatus used in connection with supply and use of water.
FIXTURE	See PLUMBING FIXTURE.
FIXTURE BRANCH	Water supply pipe between the fixture supply pipe and the water distribution pipe.
FIXTURE SUPPLY	Water supply pipe connecting the fixture with the fixture branch.
FIXTURE UNIT	A quantity in terms of which the load producing effects on the plumbing system of different kinds of plumbing fixtures are expressed on some arbitrary chosen scale.
FLOAT OPERATED VALVE	See BALL COCK.
FLOOD LEVEL RIM	The top edge of a receptacle from which water overflows.

FLUSH TANK	A tank located above water closets, urinals or similar fixtures for the purpose of flushing the usable portion of the fixture. Also known as FLUSHING CISTERN and FLUSHOMETER TANK.
FLUSH VALVE	See FLUSHOMETER VALVE.
FLUSHING CISTERN	See FLUSH TANK.
FLUSHOMETER TANK	See FLUSH TANK.
FLUSHOMETER VALVE	A device located at the bottom of the tank, and which discharges a predetermined quantity of water to fixtures for flushing purposes and is closed by direct water pressure or other mechanical means. Also known as FLUSH VALVE.
FULL FACILITIES	The modern plumbing facilities allowed to the occupants of modern dwellings or, of VIP hotels and accommodations.
ULL OPEN VALVE	A shutoff valve that in the full position has a straight through flow passageway with a diameter not less than one nominal pipe size smaller than nominal pipe size of the connecting pipe.
GEYSER	An apparatus for heating water with supply control on the inlet side and delivering it from an outlet.
GRADE	The slope or fall of a line of pipe with reference to a horizontal plane.
HANGERS	See SUPPORTS.
HORIZONTAL PIPE	Any pipe or fitting which is installed in a horizontal position or which makes an angle less than 45 degrees with the horizontal.
HOT WATER TANK	A vessel for storing hot water under pressure greater than the atmospheric pressure.
INDIVIDUAL WATER SUPPLY	A supply other than an approved public water supply which serves one or more families.
LAGGING	The material used for thermal or acoustic insulation.

LIQUID WASTE	The discharge from any fixture, appliance or appurtenance in connection with a plumbing system which does not receive faecal matter.
MAIN	The principal artery of the system, to which branches may be connected, for the purpose of water supply from a supply to individual consumers. Also known as WATER MAIN.
MECHANICAL JOINT	A connection between pipes, fittings or pipes and fittings which is neither screwed, caulked, threaded, soldered, solvent cemented, brazed nor welded.
OFFSET	A combination of approved bends in a line of piping used to connect two pipes whose axes are parallel but not in line.
PLUMBING	The business, trade or work having to do with the installation, removal, alteration or repair of plumbing and drainage systems or part thereof.
PLUMBING APPLIANCES	The plumbing fixtures whose operation or control can be dependent upon one or more energized components, such as motors, controls, heating elements, or pressure or temperature sensing elements.
PLUMBING APPURTENANCE	A manufactured device or prefabricated assembly of component parts, which is an adjunct to basic piping system and plumbing fixtures, performing some useful function in the operation, maintenance, servicing, economy or safety of a plumbing system.
PLUMBING FIXTURE	A receptacle or device which is either permanently or temporarily connected to the water distribution system of the premises, and demands a supply of water there from, or discharges used water, waste materials or sewage either directly or indirectly to the drainage system of the premises, or requires both a water supply connection and a discharge to the drainage system of the premises. Also known as FIXTURE.
PLUMBING SYSTEM	A system of potable water supply and distribution pipes, plumbing fixtures and traps, soil waste and vent pipes, and sanitary and storm sewers and building drains including their respective connections, devices and appurtenances within a building or premises.

POTABLE WATER	Water free from impurities which may cause diseases or harmful physiological effects and water which is satisfactory for drinking, culinary and domestic purposes.
PRIVATE/PRIVATE USE	Plumbing fixtures intended for the use of a family in residences, or for the restricted use of an individual in commercial establishments.
QUICK CLOSING VALVE	A valve or faucet that closes automatically when released manually or controlled by mechanical means for fast action closing.
RECEPTOR	An approved plumbing fixture or device of such material, shape and capacity as to adequately receive the discharge from indirect waste pipes, so constructed and located as to be readily cleaned.
RESIDUAL HEAD	The head available at any particular point in the distribution system.
RESTRICTED FACILITIES	The minimum plumbing facilities acceptable for the occupants of low income group.
RIM	An unobstructed open edge of a fixture.
RISER	A water supply pipe which extends vertically one full storey or more to convey water to branches or fixtures.
ROUGHING-IN	The installation of all parts of the plumbing system which can be completed prior to the installation of fixtures. This includes water supply, drainage, vent piping and necessary supports.
SERVICE PIPE	The pipe that runs between the distribution main in the street and the riser in case of a multi-storied building or the water meter in the case of an individual house and is subject to water pressure from such main.
SLIP JOINT	An adjustable tubing connection, consisting of a compression nut, a friction ring, and a compression washer, designed to fit a threaded adapter fitting, or a standard taper pipe thread.
SOLDERED JOINT	A joint obtained by the joining of metal parts with metallic mixtures of alloys which melt at a temperature below 427°C and above 149°C.

STOP VALVE	Any device (including a stopcock or stop tap) other than a draw off tap; for stopping the flow of water in a pipe at will.
STORAGE CISTERN	A container, other than a flashing cistern, having a free water surface under atmospheric pressure and used for storage of water, and is connected to the water main or tube-well by means of supply pipe. Also known as STORAGE TANK.
STORAGE TANK	See STORAGE CISTERN.
SUPPORTS	Hangers and anchors or devices for supporting and securing pipe, fixture and equipment to walls, ceilings, floors or other structural members. Also known as HANGERS.
TEMPERED WATER	The water ranging in temperature from 29°C up to 43°C.
VACUUM BREAKER	A type of backflow preventer installed on openings subject to normal atmospheric pressure.
VERTICAL PIPE	Any pipe which is installed in a vertical position or which makes an angle of not more than 45 degrees with the vertical.
WARMING PIPE	An overflow pipe so fixed that its outlet whether inside or outside a building, is in a conspicuous position where the discharge of any water there from can be readily seen.
WASHOUT VALVE	A device located at the bottom of the tank for the purpose of draining a tank for cleaning, maintenance, etc.
WATER CONDITIONING OR TREATING DEVICE	A device which conditions or treats a water supply so as to change its chemical content or remove suspended solids by filtration.
WATER HAMMER ARRESTER	A device used to absorb the pressure surge (water hammer) which occurs when water flow is suddenly stopped in a water supply system.
WATER HEATER	Any heating device that heats potable water and supplies it to the potable hot water distribution system.
WATER LINE	A line marked inside a cistern to indicate the highest water level at which the ball valve should be adjusted to shut off.
WATER MAIN	See MAIN.

WATER OUTLET	A discharge opening through which water is supplied to a fixture, into the atmosphere (except into an open tank which is part of the water supply system), to a boiler or heating system, or to any devices or equipment requiring water to operate but which are not part of the plumbing system.
WATER SUPPLY SYSTEM	A system consisting of building supply pipe, water distributing pipes, and necessary connecting pipes, fittings, control valves, and all appurtenances carrying or supplying potable water in or adjacent to the building or premises.
WELDED JOINTS OR SEAM	Any joint or seam obtained by the joining of metal parts in the plastic molten state.

5.3 Permit For Water Connection

5.3.1 Requirement of Permit

No water supply system shall be installed in a new building until a permit for such work has been issued by the Authority. The addition or alteration of the existing water supply facilities in a building shall also require a permit for their installation.

5.3.2 Application for Permit (Obtaining Public Supply Connection)

Application for a permit for water supply system shall be made in writing by the licensed plumber and the owner or his appointed person(s) or agent on a prescribed form (Appendix M).

The application shall accompany building drawings showing the water supply system with the following details:

- (a) Site plans showing the location of water main.
- (b) Typical floor plan(s) and elevations of the building with the position of different plumbing fixtures and piping.
- (c) Materials, sizes and gradients (if any) of the proposed interconnecting piping system.
- (d) Pipes (if any) conveying non-potable water (for flushing water closets and urinals) shall be marked by distinctive (durable) yellow color.
- (e) Design calculations of water requirement, indicating considerations of per capita water requirement and population.

5.3.3 Application of Permit for Bulk Water Supply

In the case of large housing colonies or where new services are so situated that it will be necessary for the Authority to lay new mains or extend an existing main, full information about the proposed housing scheme shall be furnished to the Authority; information shall also be given regarding their phased requirements of water supply with full justification. Such information shall include site plans, showing the layout of roads, footpaths, building and boundaries and indicating thereon the finished line and level of the roads or footpaths and water supply lines and appurtenances.

5.3.3.1 Application for individual (permission for DTW Installation) water supply

For private water supply facility in addition to public water main connection through installing own deep tubewell, permission must be sought submitting application to water supply Authority in a prescribed form. Necessity for such connection indicating total water requirement should be mentioned.

5.3.4 Justification of Requirement

The design calculations for water supply system of high rise and public buildings shall be submitted along with the drawings mentioned in Sec 5.3.1 above.

5.3.5 Permits and Approvals

The Building Official shall examine or cause to be examined the application for a permit and amendments thereto within 45 days from the day of receipt of such application. If the application does not conform to the provisions of this Code, it shall be rejected in writing, stating the reasons thereof. The Authority shall issue a nontransferable permit, if the proposed work satisfies the provisions of this Code (Sections 5.3.2 and 5.3.3).

5.3.6 Completion Certificate

On completion of the plumbing work for the water supply system, the licensed plumber shall give a completion certificate in the prescribed form (Appendix N) to the Authority for getting water connection from the mains.

5.4 Licensing/Registration of Plumbers

5.4.1 License Requirement

Plumbing work shall be executed only by a licensed plumber under the control of the Authority and shall be responsible to carry out all lawful directions given by the Authority. No individual, partnership, corporation or firm shall engage in the business of installation, repair or alteration of water supply system without obtaining a license from the Authority.

5.4.2 Examination and Certification of Plumber

The Authority shall establish a plumber's selection and examination board. The board will determine:

- (a) The requirements of obtaining license, i.e, (i) minimum academic qualification (ii) minimum practical vocational and other training (iii) minimum years of experience (iv) total volume of works done and
- (b) Finally, establish standards and procedures for examination of the applicants for license.

The Authority will issue license to such applicants who meet the qualifications thereof and successfully pass the examination conducted by the board.

5.4.3 Annulment of License

The license of a plumber may be annulled by the Authority, if it is proved that a plumbing work has been completed and certified by the licensed plumber violating the provisions of this Code and deliberately setting aside the approvals given in the permit or without receiving the permit from the Authority.

5.5 Water Supply Requirements

5.5.1 General

5.5.1.1 Buildings equipped with plumbing fixtures and used for human occupancy or habitation shall be provided with the supply of cold potable water in the amounts specified in Sections 5.5.2 to 5.5.4 and at the pressures specified in Sections 5.10.4.2 and 5.10.4.3. Only potable water shall be accessible to the plumbing fixtures supplying water for drinking, bathing, and culinary use and for the processing of food.

5.5.1.2 Non-potable water may be used for flushing water closets and urinals provided such water shall not be accessible for drinking or such other purposes.

5.5.2 Water Requirement for Domestic Use

According to the socio-economic status, type of habitants, population of the area and public facilities present water requirement for domestic purposes may be classified only for the purpose of this Chapter as follows:

Socio - Economic group:

- | | |
|---|---|
| x. High income group - monthly income | > 6 times monthly gross per capita income of Bangladesh |
| y. Middle income group - monthly income | < 6 times monthly gross per capita income of Bangladesh |
| z. Low income group - monthly income | < 2 times monthly gross per capita income of Bangladesh |

Type of Habitants/Population:

- (a) Metropolitan Cities/City Corporation Area/District Towns
- (b) Pourashavas/Upazilas and Urban Growth Centre
- (c) Village areas

Water requirements for daily domestic use of a building shall be assessed on the basis of the one or a combination of the following two methods:

- (a) Number of occupants according to their occupancy classification and their water requirements as specified in Tables 8.5.1(a), 8.5.1(b), 8.5.1(c) and 8.5.1(d)
- (b) Peak demand or maximum probable flow is specified in Appendix O.

Table 8.5.1(a): Water Consumption for Domestic Purposes in Residential Buildings (Cities/Big District Towns)

Category	Socio-economic group, Type of Building, Source and Other Facilities	Water Consumption	
		Full Facility (lpcd)	Restricted Facility (lpcd)
A	Metropolitan Cities/City Corporation Area/District Towns		
x	High income group:		
A1	Single family dwelling (with garden and car washing)	260	200
A3	Big multi-family apartment/flat (> 2500 sft)	200	150
y	Middle income group:		
y1	Officer's qtr./Colony and moderate apartment (< 2000 sft)	180	135
y2	Small building/staff qtr. and small apartment (< 1500 sft)	---	120
z	Low income group:		
z1	Junior staff qtr./flat (< 1000 sft) and temporary shade	---	80
z2	Stand post connection in the fringe area	---	65
z3	Common yard (stand post) connection in the fringe area	---	50
z4	Slum dwellers collection from road side public stand post	---	40

Table 8.5.1(b): Water Requirement for Domestic Purposes in Residential Buildings (Pourashavas/Upazilas/Urban growth Centers)

Category	Socio-economic group, Type of Building, Source and Other Facilities	Water Consumption	
		Full Facility (lpcd)	Restricted Facility (lpcd)
A	Pourashavas/Upazilas and Urban Growth Centre		
y	Middle income group:		
A1	Single family dwelling (with garden)	---	150
A3	Officer's qtr./colony and moderate apartment (< 2000 sft)	---	135
A3	Small building/staff qtr. and small apartment (< 1500 sft)	---	120
z	Low income group:		
z1	Junior staff qtr. /flat (< 1000 sft) and temporary shade	---	80
z2	Private stand post connection in the fringe area	---	65
z3	Common yard (stand post) connection in the fringe area	---	50
z4	Slum dwellers collection from road side public stand post	---	40

Table 8.5.1(c): Water Requirement for Domestic Purposes in Residential Buildings (Village Areas and Small Communities)

Category	Socio-economic group, Type of Building, Source and Other Facilities	Water Consumption	
		Full Facility (lpcd)	Restricted Facility (lpcd)
A	Village areas/small community from hand tubewell, dugwells, ponds and rivers (non-piped water supply system)		
z	Low income group:		
z1	Private source (own tubewell/dugwell and pond)	---	50 - 60
z2	Public sources (public tubewell/dugwell/ other sources)	---	40 - 50

Table 8.5.1(d): Domestic Water Requirements for Various other Occupancies and Facility Groups

Class of Occupancy	Occupancy Groups	For Full^a Facilities (lpcd)	For Restricted Facilities (lpcd)
A: Residential	A4: Mess, Boarding Houses, Dormitories and Hostels	135	70
	A5: Hotels and Lodging Houses (per bed)	300	135
B: Educational Facilities	B1: Educational Facilities up to Higher Secondary Levels	70	45
	B2: Facilities for Training and above Higher Secondary Education	100	70
	B3: Pre-School Facilities	50	35
C: Institutional	C1: Institution for Care of Children	180	100
	C2: Custodian Institution for Physically Capable Adults	180	100
	C3: Custodian Institution for the Incapable Adults	120	70
	C4: Penal and Mental Institutions for Children	100	60
	C5: Penal and Mental Institutions for Adults	120	70
D: Healthcare Facilities	D1: Normal Medical Facilities (Small Hospitals)	340	225
	Big Hospitals (Over 100 beds)	450	250
	D2: Emergency Medical Facilities Nurses & Medical Quarters	300 250	135 135
E: Business	E1: Offices	45	30
	E2: Research and Testing Laboratories	70	45
	E3: Essential Services	70	45
F: Mercantile	F1: Small Shops and Market	45	30
	F2: Large Shops and Market	45	30
	F3: Refueling Station	70	45
G: Industrial Buildings	G1: Low Hazard Industries	40	25
	G2: Moderate Hazards Industries	40	25

Class of Occupancy	Occupancy Groups	For Full^a Facilities (lpcd)	For Restricted Facilities (lpcd)
H: Storage Buildings	H1: Low Fire Risk Storage	10	6
	H2: Moderate Fire Risk Storage	10	6
I: Assembly	I1: Large Assembly with Fixed Seats (per seat)	90	45
	I2: Small Assembly with Fixed Seats (per seat)	90	45
	I3: Large Assembly without Fixed Seats ^b	15	10
	I4: Small Assembly without Fixed Seats	15	10
	I5: Sports Facilities	15	10
J: Hazardous Building	J1: Explosion Hazard Building	15	10
	J2: Chemical Hazard Building	15	10
	J3: Biological Hazard Building	10	6
	J4: Radiation Hazard Building	10	6
K: Garage ^c	K1: Parking Garage	15	10
	K2: Private Garage	15	10
	K3: Repair Garage	15	10
L: Utility	L: Utility	10	6
M: Miscellaneous	M1: Special Structures	-- ^d	-- ^d
	M2: Fences, Tanks and Towers	---	3

Notes:

^a For full facility in occupancy classifications A, B, C and D, the water requirement value includes 25% hot water.

^b In the case of mosques, the water requirements given above shall be adequate for ablution and other uses of one devotee per prayer. The appropriate LPCD value may be calculated on this basis.

^c Water requirement for occupancy K is shown as a provision for unknown visitors only.

^d Water requirement for occupancy M1 shall be assessed considering its nature of use and the similarity in purpose with any of the occupancies mentioned above.

5.5.3 Water Requirement for Fire Fighting

5.5.3.1 The Authority shall make provision to meet the water supply requirements for firefighting in the city/area, depending on the population density and types of occupancy.

5.5.3.2 Provision shall be made by the owner of the building for water supply requirements for firefighting purposes within the building, depending upon the height and occupancy of the building, in conformity with the requirements laid down in Part 4 of this Code.

5.5.3.3 The requirements regarding water supply in storage tanks, capacity of fire pumps, arrangements of wet riser-cum-down feeder and wet riser installations for high rise buildings, depending upon the occupancy use, shall be in accordance with Sec 4.2 Part 4 of this Code.

5.5.4 Water Requirement for Special Equipment

5.5.4.1 Water supply in many buildings is also required for many other applications other than domestic use, which must be identified in the initial stages of planning so as to provide the requisite water quantity, storage capacity and pressure as required for each application.

In such instances information about the water use and the quality required may be obtained from the users. Some typical uses other than domestic use and firefighting purposes are air conditioning and air washing, swimming pools and water bodies and gardening. The water requirement for special equipment like air-conditioning or such others shall be based on the specification of the manufacturer.

5.6 Estimation of Demand Load

5.6.1 Estimates of total water supply requirements for buildings shall be based on the estimation of total present and predicted future population and per capita water requirement as mentioned in Sec 5.5.

5.6.2 In making assessment of water supply requirements of large complexes, the future occupant load shall be kept in view. Use may be made of the following methods for estimating future requirements.

- (a) Demographic method of population projection,
- (b) Arithmetic progression method,
- (c) Geometrical progression method,
- (d) Method of varying increment or incremental increase,
- (e) Logistic method,
- (f) Graphical projection method, and
- (g) Graphical comparison method.

5.6.3 For residential buildings, the requirements of water shall be based on the actual number of occupants; where this information is not available, the number of occupants for each residential unit may be based on a family size around 5 (five). For assessing the population in other occupancies, reference may be made to Part 4 of this Code.

5.6.4 To estimate office building occupancy, allow 7.4 to 9.3 m² (80 to 100 ft²) of floor space per person, depending on the type of office building, exclusive of elevator and stair space, corridors, or service areas.

5.6.5 To determine the present and future water requirement:

- (a) Classify the total population based on the basis socio-economic status (higher/middle/lower income group and slum dwellers)
- (b) Determine per capita water requirement for different categories (types) of people for different type of domestic, recreational, and commercial uses.
- (c) Multiply the population with per capita water consumption to determine the present and future water requirement.

5.7 Water Sources and Quality

5.7.1 Sources of Water

The origin of all sources of water is rainfall, Water can be collected as it falls as rain before it reaches the ground; or as surface water when it flows over the ground or is pooled in lakes or ponds; or as ground water when it percolates into the ground and flows or collects as ground water; or from the sea into which it finally flows. Surface waters are physically and microbially contaminated and cannot be used without treatment, on the other hand ground water sources are chemically contaminated and treatment may be necessary in many cases.

5.7.2 Quality of Water

The quality of water to be used for drinking shall be maintained using WHO Water Safety Plan (WSP) and shall comply with the Environment Conservation Rules (ECR, 1997) and WHO Guideline (2004) Values as presented in Appendix P. For purposes other than drinking, water if supplied separately, shall be safe from bacteriological contamination so as to ensure that there is no danger to the health of the users due to such contaminants.

5.7.3 Waste Water Reclamation

Treated sewage or other waste water of the community may be utilized for non-domestic purposes such as water for cooling, flushing, lawns, parks, firefighting and for certain industrial purposes after giving the necessary treatment to suit nature of the use. This supply system shall be allowed in residences only if proper provision is made to avoid a cross connection of treated waste water with domestic water supply system.

Whenever a building is used after long intervals, the water quality of the stored water must be checked so as to ensure that the water is safe for use as per water quality requirements specified in this Code.

5.8 Water Supply System

Each floor or unit within the water supply system shall be provided with a control valve in addition to the main control valve at the entrance of the system. One of the following public water supply systems shall be adopted for distributing water to the plumbing fixtures within the building [see Appendix O].

5.8.1 Direct Connection to Water Main

For continuous water supply system with sufficient pressure to feed all plumbing fixtures during peak demand period, the direct connection of water distribution system to the water mains may be adopted. However, direct pumping from the public water main should strictly be prohibited.

5.8.2 System Incorporating Balancing Roof Tank

For continuous water supply system with inadequate pressure only during peak demand hour or for intermittent water supply with sufficient pressure to feed balancing tank, a balancing roof tank shall be required to feed plumbing fixtures within the building. The connection to the balancing roof tank from the water main or from ground tank or from individual water sources shall be through a non-return valve.

5.8.3 System Incorporating Ground Tank

For water supply system with inadequate pressure to feed plumbing fixtures or balancing roof tank, the building premises shall have a ground (or underground) tank to store water. The water from the ground tank shall be boosted up to the roof tank to feed plumbing fixtures. The connection of water main to the ground tank shall be through a ball valve system. Installation of booster pump directly into the water main shall not be allowed. Since, this system cannot ensure protection against possible contamination (particularly during flood), disinfection system should be incorporated.

5.8.4 Individual Water Supply

In the absence of a public water supply system, or In case of need of additional supply of water, the building premises shall have individual water supply as specified in Sec 5.23.1. The water from the sources (DTW) shall be boosted up to the roof storage tank to feed plumbing fixtures. The system shall be protected as specified in Sections 5.13.3 through 5.23.7.

5.9 Storage of Water

5.9.1 Capacity of Storage Tank

5.9.1.1 The type and capacity of a storage tank shall be determined considering the following factors:

- (a) The rate and regularity of supply
- (b) The frequency of replenishment of the storage tank during 24 hours

- (c) Building occupancy classification
- (d) Hours of supply of water at sufficiently high pressure to fill up the roof storage tank in absence of a ground (or underground) storage tank
- (e) The amount of water required for firefighting and method of firefighting system (See Part 4)
- (f) The amount of water required by special equipment (Sec 5.5.4).

5.9.1.2 The size and volume of a storage tank shall be calculated considering the following factors:

- (a) The amount of storage to be provided is a function of capacity of the distribution network, the location of the service storage, and the use to which it is to be put.
- (b) To compute the required equalizing or operating storage, a mass diagram or hydrograph indicating the hourly rate of consumption is required. The procedure to be used in determining the needed storage volume follows:
 - (i) Obtain a hydrograph of hourly demands for the maximum day, through a study of available records.
 - (ii) Tabulate the hourly demand data for the maximum day and draw a cumulative demand curve,
 - (iii) The required operating storage is found by comparing (maximum deviation) the cumulative demand curve (S- Shaped Curve) with cumulative pumping curve (Straight line) plotted on it.
- (c) The required capacity of a tank varies with the capacity and running time of the house or fill pumps, however, following procedure may be followed to determine the capacity of storage tanks and pump:
 - (i) Capacity of Roof Tank = $\frac{1}{2}$ x Total daily demand of water (m^3) + 1 hr. reserve (m^3) for fire-fighting requirement (for tall building). Therefore, two times filling of roof tank will meet the daily requirement.
 - (ii) Capacity of Delivery Pump = Peak hourly demand of water, **lph**. Therefore, daily pumping period would be around 7 - 8 hours (2-3 hours in the morning + 3 hours in the afternoon + 2 hours in the evening).
 - (iii) Capacity of Under Ground Reservoir = 1 x Total daily demand of water (m^3) + 1 hr. reserve (m^3) for firefighting (for tall building). For emergency requirement 2-3 days daily demand of water is sometimes stored.

5.9.2 Construction of Storage Tank

5.9.2.1 General

Storage tank shall be easily accessible for inspection and cleaning. The tank shall be provided with adequate size of valved drains at its lowest point in accordance with Table 8.5.2. The water supply inlet into the storage tank shall be at an elevation that is required for an air gap in an open tank with overflow (Sec 5.18.6) or 100 mm above the overflow whichever is greater. The diameter of overflow pipe shall not be less than the size shown in Table 8.5.3 for the specific discharge into storage tank. The storage tank shall be equipped with water tight and vermin and rodent proof cover. The tank shall be provided with return bend vent pipe with an open area not less than half the area of the riser (up feed or down feed). All openings (overflow pipe and vent pipe) shall be provided with corrosion resistant screens against the entrance of insects and vermin. There must be at least two compartments/units for alternative cleaning.

Table 8.5.2: Sizes of Storage Tank Drainage Pipes

Tank Capacity (V) in Liters	Diameter of Drainage Pipe (mm)
$V \leq 2800$	25
$2800 < V \leq 5500$	38
$5500 < V \leq 11000$	50
$11000 < V \leq 19000$	63
$19000 < V \leq 28000$	75
$28000 < V$	100

Table 8.5.3: Sizes of Overflow Pipes for Storage Tank

Maximum Discharge (Q) of Water Supply Pipe into Storage Tank (l/min)	Diameter of Overflow Pipe (mm)
$Q \leq 190$	50
$190 < Q \leq 570$	63
$570 < Q \leq 760$	75
$760 < Q \leq 1500$	100
$1500 < Q \leq 2650$	125
$2650 < Q \leq 3800$	150
$3800 < Q$	200

5.9.2.2 Roof storage tank

The roof storage tank shall be constructed with pre-stressed or reinforced concrete or ferro-cement or galvanized steel or of the material that will resist any action by the plain or chlorinated water. The tank shall be made of water tight without the use of putty. Tanks made of non-galvanized metal sheets shall be coated internally with a nontoxic material which does not impart a taste or odor. The metal storage tank shall be coated externally with a good quality anticorrosive weather resistant paint. The outlet of storage tank to the distribution system shall be at least 50 mm above the tank bottom.

To provide sufficient pressure, the bottom of the tank must be elevated sufficiently above the highest floor water fixtures.

Vent pipe should be provided to avoid any air lock and should be placed where the horizontal branch pipes connect the vertical down feed pipes (not adjacent to storage tank and at interconnection place between storage tank and distribution pipes).

5.9.2.3 Ground or underground storage tank

The ground or underground storage tank shall be constructed of either pre-stressed or reinforced concrete or ferrocement. The tank shall be absolutely waterproof and have a water tight cast iron manhole cover suitable for inspection. The inside and outside of the tank may be coated with nontoxic and waterproof materials. The ground tank shall be placed at a location so as to avoid contamination by flood water or any other sources. Each compartment/units should be divided in two chambers with provision of sump for longer contact time with chlorine and easy cleaning.

5.10 Design of Distribution System

5.10.1 Rate of Flow of Water

One of the important items that need to be determined before the sizes of pipes and fittings for any part of the water piping system may be decided upon is the rate of flow in the service pipe which, in turn depends upon the number of hours for which the supply is available at sufficiently high pressure. If the number of hours for which the supply is available is less, there will be large number of fittings in use simultaneously and the rate of flow will be correspondingly large.

The data required for determining the size of the communication and service pipes are:

- (a) the maximum rate of discharge required at peak demand period (Peak hourly demand of water)

$$= \frac{\text{Total daily requirement of water}}{\text{Hour of water consumption (usually 15 to 17 hours)}} \times \text{Peak Factor (usually 2.2)} \quad (8.5.1)$$

- (b) the length of the pipe; and

- (c) the head loss by friction in pipes, fittings and meters.

For head loss calculation in piping system—

- (i) Determine the total length of pipe and calculate the Equivalent Pipe Length (Head Loss from bend, gate valves, reducer etc.) from Table O.2 of Appendix O of Part 8.

- (ii) Consider maximum permissible head loss of 1.5-1.6 m/100 m and assume the probable maximum velocity of flow (v) against tentative diameter of pipes (d) as follows;

For tentative diameter of pipe 13 mm and 50 mm: 0.30 - 0.60 m/sec

For tentative diameter of pipe 75 mm and 100 mm: 0.75 - 0.90 m/sec

For tentative diameter of pipe 150 mm and 200 mm: 1.15 - 1.30 m/sec

- (iii) Determination of total head loss (h_f) from Hazen William's Nomograph (Appendix O) or friction loss formula, $h_f = \frac{4fLV^2}{2gd}$, where, f = friction loss

factor, L = length of pipe, v = velocity of flow and d = diameter of pipe.

5.10.2 Discharge Computation

5.10.2.1 Based on fixture units

The design of the consumers' pipes or the supply pipe to the fixtures is based on:

- the number and kind of fixtures installed;
- the fixture unit flow rate; and
- the probable simultaneous use of these fixtures.

The rates at which water is desirably drawn into different types of fixtures are known. These rates become whole numbers of small size when they are expressed in fixture unit. The fixture units for different sanitary appliances or groups of appliances are given in Table 8.5.4.

5.10.2.2 Probable simultaneous demand (Hunter Curve)

The possibility of drawing water at the same time by all water supply taps in any system of domestic and commercial use is extremely remote. Designing the water mains for the gross flow will result in larger and uneconomical pipe mains and is not necessary. A probability study made by Hunter suggests the relationship as shown in Appendix O and may also be calculated from Table 8.5.5.

5.10.3 Pipe Size Computation

Commercially available standard sizes of pipes are only to be used against the sizes arrived at by actual design. Therefore, several empirical formulae are used, even though they give less accurate results. The Hazen and William's formula and the charts based on the same may be used without any risk of inaccuracy in view of the fact that the pipes normally to be used for water supply are of smaller sizes. For nomogram of Hazen and William's equation see Appendix O.

5.10.4 General Features of Distribution System Design

5.10.4.1 The water supply system shall be designed to supply minimum but requisite quantity of water to all fixtures, devices and appurtenances in every section of the building with adequate pressure. The design requirements of a water supply system are presented in Table 8.5.6.

Table 8.5.4: Fixture Unit for different Types of Fixtures with Inlet Pipe Diameter

Sl. No.	Type of Fixture	Fixture Unit (FU) as Load Factor	Minimum Size of Fixture Branch, mm
1	Ablution Tap	1	15
2	Bath tub supply with spout	3	15
3	Shower Stall Domestic	2	15
4	Shower in Group per head	3	15
5	Wash Basin (Domestic Use)	1	15
6	Wash Basin (Public Use)	2	15
7	Wash Basin (Surgical)	2	15
8	Kitchen Sink (Domestic Use)	2	15/20
9	Washing Machine	3	15/20
10	Drinking Fountain	0.5	15

Table 8.5.5: Probable Simultaneous Demand

No. of Fixture Units	System with Flush Tanks Demand (Based on Fixture Units)		System with Flush Valves Demand (After Hunter)	
	Unit Rate of Flow ¹)	Flow in Litre/Minute	Unit Rate of Flow ¹)	Flow (Litre/Minute)
20	2.0	56.6	4.7	133.1
40	3.3	93.4	6.3	178.4
60	4.3	121.8	7.4	209.5
80	5.1	144.4	8.3	235.0
100	5.7	161.4	9.1	257.7
120	6.4	181.2	9.8	277.5
140	7.1	201.0	10.4	294.5
160	7.6	215.2	11.0	311.5
180	8.2	232.2	11.6	328.5
200	8.6	243.5	12.3	348.3
220	9.2	260.5	12.7	359.6
240	9.6	271.8	13.1	370.9
300	11.4	322.8	14.7	416.2
400	14.0	396.4	17.0	481.4
500	16.7	472.9	19.0	538.0
600	19.4	549.3	21.1	597.5
700	21.4	606.0	23.0	651.3
800	24.1	682.4	24.5	693.7
900	26.1	739.0	26.1	739.0
1000	28.1	795.7	28.1	795.7

¹ Unit rate of flow= Effective fixture units.

Table 8.5.6: Water Supply System Design Requirements

Fixture	Supply Control	Minimum Size of Supply Pipe (mm)	Required Flow Pressure (kPa)	Required Flow Rate (lpm)
Bathroom group	Flush tank	-	55	--
Bathroom group	Flushometer valve	-	55	--
Bathtub	Faucet	13	55	15.1
Clothes washer		13	55	--
Combination fixture	Faucet	13	55	--
Dishwashing machine		13	55	10.4
Drinking fountain	Faucet	13	55	2.8
Kitchen sink	Faucet	13	55	9.5
Laundry tray	Faucet	13	55	15.1
Wash basin	Faucet	19	55	--
Pedestal urinal	Flush tank	13	55	56.8
Pedestal urinal	Flushometer valve	19	100	56.8
Restaurant sink	Faucet	19	55	--
Service sink	Faucet	13	55	11.4
Shower head	Mixing valve	13	55	11.4
Water closet	Flush tank	19	55	11.4
Water closet	Flushometer tank	19	55	6.1
Water closet	Flushometer valve	25	100	132
For fixture not listed here but maximum supply size requirement		13	55	--
		19	55	--
		25	100	--

5.10.4.2 For a down feed water distribution system (roof tank supply), static pressure due to gravity increases with increasing floor height (4.32 psi or 0.3 Bar per floor of 10 ft. height at non-flow condition). Therefore, water distribution pipe in a building shall be maintained at a pressure so that none of their fittings shall be subject to a water head greater than 35 m (345 kPa \approx 50 psi).

5.10.4.3 The distribution system shall be maintained at a pressure not less than those specified in Table- 8.5.6 during peak demand period.

5.10.4.4 The minimum size of supply pipe for different fixtures shall be in accordance with Table 8.5.6. The fixture supply shall not terminate more than 0.75 m (2.5 ft.) from the point of connection to the fixture. A reduced size flexible water connection pipe shall be used.

5.10.4.5 The water flow velocity in the distribution system shall be controlled to minimize the possibility of water hammer.

5.10.4.6 The design of water distribution system shall conform to approve engineering practices. An alternative guide to the design of a building water distribution system is also presented in Appendix O.

Note: The sizing of water distribution piping within the building may be made either by considering the velocity of flow or by velocity of flow and pressure loss as governing parameters. The first method have limited application for one or two storey buildings provided the minimum available pressure is sufficient to operate the highest or most remote fixtures during peak demand period. The second method provides better estimate of pipe sizes for a water distribution system.

5.10.5 Design of Water Distribution Pump

The capacity of a water delivery pump can be calculated from the estimated maximum rate of flow (Q) of water in gpm, and total head ($H = h_s + h_d + h_f + h_y$) of supply of water in ft. and using the following formula:

$$\text{Break Horse Power, BHP} = \frac{H \times Q}{3960 \times E} \quad (8.5.2)$$

Where, static head (h_s) is the total suction lift of water (sum of vertical distance between the underground reservoir and pump level), delivery head (h_d) is the vertical distance between the pump level and roof tank storage point and E is the efficiency of the pump in percent.

Frictional head loss (h_f) can be determined for whole length (vertical and horizontal) of pipe flow using the procedures described in Section 5.10.1(c).

$$\text{Velocity head, } h_v = \frac{v^2}{2g} \quad (8.5.3)$$

Where, v = velocity of flow of water at discharge point in roof tank and g is the acceleration due to gravity.

5.11 Water Distribution in Tall Buildings

5.11.1 Distribution Methods

In tall buildings some of the fixtures at the lower level may be subject to excessive pressure. The sanitary appliances and fittings in tall buildings shall not be subject to a pressure of greater than 350 kPa. This shall be achieved by one or a combination of the following two methods:

- (a) Zoning Floors by Intermediate Tank: High rise buildings shall be zoned by providing intermediate tanks on different floors, each feeding a zone ranging from 5 - 6 storied so that the plumbing fixtures are not subjected to excessive pressure. Distribution in each zone shall be through independent down-take pipes from intermediate tanks as shown in Appendix O. The floors on which an intermediate tank is located shall be fed from the story above it.
 - (i) System Incorporating Intermediate Tanks Supplied by Storage Tank - Water required for the building shall be pumped from the underground tank to the storage tank. The intermediate tanks shall be fed from the storage tank through a separate down take pipe.
 - (ii) System Incorporating Intermediate Tanks Supplied by Independent Pumps - Alternatively the intermediate tanks may be supplied from the underground tank through independent pumps.
- (b) System Incorporating Pressure Reducing Valves: The excessive pressures suffered by different fixtures shall be minimized by pressure reduction valves.
- (c) Hydro-Pneumatic System: This system may be adopted where the source is independent of public water supply system. In this system the supply shall be through a pneumatic pressure vessel fitted with accessories like non-return and pressure relief valves. The pump and compressor shall be automatically controlled through an electric control panel to provide air and water as and when needed.

5.11.2 Recirculation of Waste Water

Recirculation of cooling water and/or waste water from wash basin to the cistern of water closets and urinals in the lower floor may be provisioned only through a separate tank. No connection between potable water supply line and re-circulated waste water line shall be allowed with or without any non-reflex or non-return valves.

5.12 HOT WATER SUPPLY INSTALLATION

5.12.1 Hot Water Requirements

For a residential building, hot water may be supplied to all plumbing fixtures and equipment used for bathing, washing, cleansing, laundry and culinary purposes. For a nonresidential building, hot water may be supplied for bathing and washing purposes. Water requirement for hot water supply shall be in accordance with Sec 5.5.

5.12.2 Storage Temperature

The design of hot water supply system may be based upon the following temperature requirement:

Scalding	68°C
Hot bath	41°C
Warm bath	37°C
Tepid bath	30°C
Sink	60°C

5.12.3 Storage Capacity

The capacity of hot water vessel shall be based on the maximum short time demand of the premises.

5.12.4 Hot Water Heater

The hot water heater shall conform to the following standards: BS 758, BS 779, BS 843, BS 855, BS 1250, BS 2883 and those specified in Part 5 of this Code.

5.12.5 Cold Water Supply Connection to Water Heaters

The connection of cold water supply piping into water heater shall be made near its bottom. The minimum size of cold water supply piping shall be based on the probable hot water demand of different fixtures but not less than 25 mm. The supply pipe shall deliver cold water into hot water cylinder as follows:

- The water heater (electric or gas) of less than 15 liters storage capacity may be directly connected to the water main through a non-return valve.
- The storage heater of 20 to 70 liters capacity may be connected directly to the water main through a non-return valve and with an additional device that will prevent the siphonage of hot water back to the water main.
- The enclosed water heater with storage capacity greater than 70 liters shall be fed from the storage tank. This water heater shall not be connected directly to the water main.

- (d) The water supply connection to an open vessel type water heater may be made with an air gap of at least 15 mm above the top edge of the water heater. Ball valve connection shall not be used to control the flow of water into this water heater.

5.12.6 Hot Water Distribution Piping

The connection of hot water distribution pipe to the hot water cylinder shall be at the top of the cylinder. The installation of piping shall be such as to avoid airlock. In case of hot water horizontal piping the gradient shall not be less than 1 in 250.

5.12.6.1 The procedure for sizing may be the same as that for cold water distribution system in Section- 5.10 but in no case shall the size be less than that specified in Table 8.5.7.

Table 8.5.7: Minimum Pipe Size for Hot Water Piping

Different Pipes	Minimum Diameter(mm)
The size of main distributing pipe that supplies hot water to the fixtures in the same storey of the hot water cylinder	25
The size of main distributing pipe that supplies hot water to the fixtures not in the same storey of hot water cylinder	19
Branch pipe supplying hot water to the bath tub or shower	19
Branch pipe supplying hot water to the sink	19
Branch pipe supplying hot water to the wash basin	19

5.12.6.2 The design consideration of hot water piping shall be such that hot water will appear quickly at the outlet of different fixtures. To improve the situation, a secondary circulation system with flow and return pipe from and to the hot water cylinder (Figure 8.5.1) may be adopted. The length of hot water distribution pipe measured along the pipe from the top of draw off tap to the hot water cylinder or the secondary circulation pipe shall not exceed the length prescribed in Table 8.5.8. The draw-off tap shall not be connected to the primary flow or return pipe.

Table 8.5.8: Maximum Permissible Length of Hot Water Draw Off Pipe

Largest Internal Diameter (D) of Pipe	Length of Pipe (m)
D < 19 mm	12
20 mm < D < 25 mm	7.5
25 mm < D	3

5.12.7 Vent Pipe

The pressure type hot water heater shall be provided with a vent pipe of not less than 19 mm diameter. The vent pipe shall rise vertically above the water line of cold water tank by at least 150 mm plus 1 mm for every 30 mm height of waterline above the bottom of the water heater.

The vent pipe shall be connected to the top of the hot water cylinder. The vent pipe may be used to supply hot water to the point in between the cold water tank and the hot water cylinder. The vent pipe shall not be provided with any valve or check valves.

The termination of vent pipe shall be such as not to cause any accidental discharge to hurt or scald any passerby or person in the vicinity.

5.12.8 Capacity of Cold Water Storage Tank

The storage capacity of cold water cistern shall be at least equal to the size of hot water storage cylinder if the cold water cistern supplies water only to the hot water heater cylinder. This capacity shall be at least twice the capacity of hot water heater cylinder if the cold water storage tank also supplies water to the cold water draw off taps.

5.12.9 Safety Devices

The temperature relief valve or pressure relief valve or a combination of temperature and pressure relief valves shall be installed for the equipment for heating or storage of hot water. The temperature relief valve shall be set at a maximum temperature of 99°C. The maximum pressure rating of water heater shall not be more than 1000 kPa. The temperature relief valve shall be placed directly above the cylinder it serves but in no case more than 75 mm away from the cylinder. The location of pressure relief valve shall be close to the equipment it serves. There shall be no valve connection in between a relief valve and the hot water cylinder it serves.

5.12.10 Wastes from Relief Valve

The outlet of pressure, temperature or such other valve shall not be directly connected to the drainage system.

5.12.11 Drain Cock

Adequate size of drain cock shall be provided with all storage tanks for their proper cleaning.

5.13 Materials, Fittings and Appliances

- (a) The materials and fittings for water supply and distribution pipe and for storage tank shall comply with the standards listed in Part 5 of this Code and those specified in this Section.
- (b) The materials chosen shall be resistant to corrosion, both inside and outside or shall be suitably protected against corrosion and free from all toxic and harmful substances. Polyethylene and un-plasticized PVC pipes shall not be installed near hot water pipes or near any other heat source.
- (c) All jointing of pipes and fittings shall be done in accordance with acceptable standard practices.

5.13.1 Water Supply Service and Distribution Pipes

Water supply service and distribution pipes shall conform to the standards listed in Tables 8.5.9 and 8.5.10. The water supply pipes and tubing used outside the building or underground shall have a minimum working pressure of 1.1 MPa at 23°C. In case of water supply exceeding 1.1 MPa pressure, the piping material shall have at least a rated working pressure equal to the highest available pressure. The hot water distribution piping shall have a minimum pressure of 550 kPa at 80°C. Different types/classes of uPVC (Un-plasticized PVC pipes) are used both for service and internal distribution pipes as described in Table 8.5.11. However, Polyvinyl chloride (PVC) plastic pipes shall not be used exposed and unprotected as riser or water distribution pipe. Polythene or un-plasticized PVC pipes shall not be installed near the heaters or hot water piping. Lead pipes may be used only for flushing and overflow purposes in a water supply system.

5.13.2 Pipe Fittings

The pipe fittings shall be in accordance with the standards listed in Table 8.5.12 and specified in Part 5.

5.13.3 Concrete, Pre-stressed or Ferro-cement Structures

The properties of the materials used for storage tank or such other structures shall conform to the material standards specified in Part 5 of the Code.

Table 8.5.9: Water Supply Service Pipe

Materials	Standards
Acrylonitrile butadiene styrene (ABS) plastic pipe	ASTM D1527, ASTM D2282
Brass pipe	ASTM B43
Cast iron water pipe	ASTM D377
Copper or Copper-alloy pipe	ASTM B42, ASTM B302
Copper or Copper-alloy tubing	ASTM B75, ASTM B88, ASTM B251, ASTM B447
Chlorinated polyvinyl chloride (CPVC) pipe	ASTM D2846, ASTM F441, ASTM F442
Galvanized steel pipe	ASTM A53
Polybutylene (PB) plastic pipe and tubing	ASTM D2662, ASTM D2666, ASTM D3309
Polyethylene (PE) plastic pipe and tubing	ASTM D2239, ASTM D2737
PVC plastic pipe	ASTM D1785, ASTM D2241, ASTM D2672

Table 8.5.10: Water Distribution Pipe

Material	Standard
Brass pipe	ASTM B43
Copper or Copper-alloy pipe	ASTM B42, ASTM B302
Copper or Copper-alloy tubing	ASTM B75, ASTM B88, ASTM B251, ASTM B477
CPVC plastic pipe and tubing	ASTM D2846, ASTM F441, ASTM F442
Galvanized steel pipe	ASTM A53
PVC plastic pipe	ASTM D1785, ASTM D2241, ASTM D2672

Table 8.5.11(a): Working Pressure Range of Different Types of uPVC (Un-plasticized PVC) Pipes

Material	Type/Class	(Bar)	(kg/cm ²)
uPVC Pipe	Class – B	6.0	6.12
uPVC Pipe	Class – C	9.0	9.19
uPVC Pipe	Class – D	12.0	12.25
uPVC Pipe	Class – E	15.0	15.30

Table 8.5.11 (b): Average Wall Thickness Class- E uPVC (Un-plasticized PVC) Pipes

Average Wall Thickness of Class- E Type uPVC Pipe			
3/8 inch (9.5 mm) Ø	½ inch (13 mm) Ø	¾ inch (19 mm) Ø	1.0 inch (25 mm) Ø
1.9 mm	2.1 mm	2.5 mm	2.7 mm

Table 8.5.12: Pipe Fittings

Material	Standard
Asbestos cement	ISO 160, ISO 881, ISO 392
Cast iron	ASME B164, ASME B16.12
Copper or copper alloy	ASME B16.15, ASME B16.18, ASME B1622, ASME B16.23, ASME B16.26, ASME B16.29, ASME B16.32
Grey iron and ductile iron	AWWA C110, ISO 2531
Malleable iron	ASME B16.3
Plastic , uPVC	ASTM D2464, ASTM D2466, ASTM D2467, ASTM D2609, ASTM F409, ASTM F437, ASTM F438, ASTM F439
Steel	ASME B16.9, ASME B16.11, ASME B16.28

5.14 General Requirement for Pipe Work

5.14.1 Public Water Mains

The following principles shall apply for the mains:

- (a) Service mains shall be of adequate size to give the required rate of flow.
- (b) The mains shall be divided into sections by making loop system and with the provisions of sluice valves and other valves so that any part of water main may be shut off for repairs without affecting major part of pipe network
- (c) To avoid dead ends, the mains shall be arranged in a grid formation or in a network.
- (d) Where dead ends are unavoidable, a hydrant shall be provided to act as a wash-out
- (e) The wash-out valve shall not discharge directly into a drain or sewer, or into a manhole or chamber directly connected to it; an effectively trapped chamber shall be interposed, into which the wash-out shall discharge.
- (f) Air valves shall be provided at all summits, and wash-out at low points between summits.
- (g) Mains need not be laid at unvarying gradients, but may follow the general contour of the ground. They shall, however, fall continuously towards the wash-out and rise towards the air valves. The gradient shall be such that there shall always be a positive pressure at every point under working conditions.
- (h) The cover for the mains shall be at least 900 mm under roadways and 750 mm in the case of footpaths. This cover shall be measured from the top of the pipe to the surface of the ground.
- (i) The mains shall be located sufficiently away from other service lines like electric and telegraph cables to ensure safety and where the mains cannot be located away from such lines, suitable protective measures shall be accorded to the mains.

5.14.2 Interconnection Pipes from Water Main

- (a) Every premises that is supplied with water by the Authority shall have its own separate communication pipe. In the case of a group or block of premises belonging to the same owner the same communication pipe may supply water to more than one premises with the prior permission of the Authority.
- (b) The communication pipe between the water main and the stop-cock at the boundary of the premises shall be laid by the Authority.

- (c) Connections up to 50 mm diameter may be made on the water main by means of screwed ferrules, provided the size of the connections does not exceed one-third the size of the water main. In all other cases, the connection shall be made by a T-branch off the water main.
- (d) As far as practicable, the communication pipe and the underground service pipe shall be laid at right angles to the main and in approximately straight lines to facilitate location for repairs. It is also recommended that the communication pipe be laid in a pipe in pipe sleeve of larger dia. Made of non-corrosive material to protect the communication pipe.
- (e) Every communication pipe shall have a stopcock and meter inserted in it. The waterway of each such fitting shall not be less than the internal sectional area of the communication pipe and the fittings shall be located within the premises at a conspicuous place accessible to Authority which shall have exclusive control over it.

5.14.3 User/Consumer Pipes

- (a) No consumer pipe shall be laid in the premises to connect the communication pipe without the approval of the Authority.
- (b) The consumer pipe within the premises shall be laid underground with a suitable cover to safeguard against damage from traffic and extremes of weather.
- (c) To control the branch pipe to each separately occupied part of a building supplied by a common service pipe, a stop tap shall be fixed to minimize the interruption of the supply during repairs. All such stop valves shall be fixed in accessible positions and properly protected. To supply water for drinking or for culinary purposes, direct taps shall be provided on the branch pipes connected directly to the consumer pipe. In the case of multi-storied buildings, down-take taps shall be supplied from overhead tanks.
- (d) Pumps shall not be allowed on the service pipe, as they cause a drop in pressure on the suction side, thereby affecting the supply to the adjoining properties. In cases where pumping is required, a properly protected storage tank of adequate capacity shall be provided to feed the pump.
- (e) No direct boosting (by booster pumps) shall be allowed from the service pipes (communication and consumer pipes).
- (f) Consumer pipes shall be so designed and constructed as to avoid air-locks. Draining taps shall be provided at the lowest points from which the piping shall rise continuously to draw-off taps.
- (g) Consumer pipes shall be so designed as to reduce the production and transmission of noise as much as possible.

-
- (h) Consumer pipes in roof spaces and unventilated air spaces under floors or in basements shall be protected against corrosion.
 - (i) Consumer pipes shall be so located that they are not unduly exposed to accidental damage and shall be fixed in such positions as to facilitate cleaning and avoid accumulations of dirt.
 - (j) All consumer pipes shall be so laid as to permit expansion and contraction or other movements.

5.14.4 Prohibited Connections

- (a) A service pipe shall not be connected into any distribution pipe; such connection may permit the backflow of water from a cistern into the service pipe, in certain circumstances, with consequent danger of contamination and depletion of storage capacity. It might also result in pipes and fittings being subjected to a pressure higher than that for which they are designed, and in flooding from overflowing cisterns.
- (b) No pipe for conveyance or in connection with water supplied by the Authority shall communicate with any other receptacle used or capable of being used for conveyance other than water supplied by the Authority.
- (c) Where storage tanks are provided, no person shall connect or be permitted to connect any service pipe with any distributing pipe.
- (d) No service or supply pipe shall be connected directly to any water-closet or a urinal. All such supplies shall be from flushing cisterns which shall be supplied from storage tank.
- (e) No service or supply pipe shall be connected directly to any hot water system or to any other apparatus used for heating other than through a feed cistern thereof.

5.15 Safe Conveyance and Distribution of Water & Prevention of Backflow

5.15.1 Basic Principles

- (a) Wholesome water supply provided for drinking and culinary purposes shall not be liable to contamination from any less satisfactory water. There shall, therefore, be no cross-connection whatsoever between the distribution system for wholesome water and any pipe or fitting containing unwholesome water, or water liable to contamination, or of uncertain quality, or water which has been used for any other purpose. The provision of reflux or non-return valves, or closed and sealed stop valves shall not be construed as a permissible substitute for complete absence of cross connection.

-
- (b) The design of the pipe work shall be such that there is no possibility of backflow towards the source of supply from any cistern or appliance, whether by siphonage or otherwise. Reflux non-return valves shall not be relied upon to prevent such backflow.
- (c) Where a supply of less satisfactory water than wholesome water becomes inevitable as an alternative or is required to be mixed with the latter, it shall be delivered only into a cistern and by a pipe or fitting discharging into the air gap at a height above the top edge of the cistern equal to twice its nominal bore and in no case less than 150 mm. It is necessary to maintain a definite air gap in all appliances or taps used in water closets.
- (d) All pipe work shall be so designed, laid or fixed and maintained as to remain completely water-tight, thereby avoiding wastage, damage to property and the risk of contamination.
- (e) No water supply line shall be laid or fixed so as to pass into or through any sewer, scour outlet or drain or any manhole connected therewith nor through any ash pit or manure pit or any material of such nature that is likely to cause undue deterioration of the pipe, except where it is unavoidable.
- (f) Where the laying of any pipe through corrosive soil or previous material is unavoidable, the piping shall be properly protected from contact with such soil or material by being carried through an exterior cast iron tube or by some other suitable means as approved by the Authority. Any existing piping or fitting laid or fixed, which does not comply with the above requirements, shall be removed immediately by the consumer and re-laid by him in conformity with the above requirements and to the satisfaction of the Authority.
- (g) Where lines have to be laid in close proximity to electric cables or in corrosive soils, adequate precautions/protection should be taken to avoid corrosion.
- (h) Underground piping shall be laid at such a depth that it is unlikely to be damaged by frost or traffic loads and vibrations. It shall not be laid in ground liable to subsidence, but where such ground cannot be avoided, special precautions shall be taken to avoid damage to the piping. Where piping has to be laid across recently disturbed ground, the ground shall be thoroughly consolidated so as to provide a continuous and even support.
- (i) Undesigning and planning the layout of the pipe work, due attention shall be given to the maximum rate of discharge required, economy in labor and materials, protection against damage and corrosion, water hammer, protection from frost, if required, and to avoidance of airlocks, noise transmission and unsightly arrangement.

- (j) To reduce frictional losses, piping shall be as smooth as possible inside. Methods of jointing shall be such as to avoid internal roughness and projection at the joints, whether of the jointing materials or otherwise.
- (k) Change in diameter and in direction shall preferably be gradual rather than abrupt to avoid undue loss of head. No bend or curve in piping shall be made which is likely to materially diminish or alter the cross section.
- (l) No boiler for generating steam or closed boilers of any description or any machinery shall be supplied directly from a service or supply pipe. Every such boiler or machinery shall be supplied from a feed cistern.

5.15.2 Backflow Prevention

- (a) The installation shall be such that water delivered is not liable to become contaminated or that contamination of the public water supply does not occur.
- (b) The various types of piping and mechanical devices acceptable for backflow protection are:
 - (i) Barometric loop,
 - (ii) Air gap,
 - (iii) Atmosphere vacuum breaker,
 - (iv) Pressure vacuum breaker,
 - (v) Double check valve, and
 - (vi) Reduced pressure backflow device.
- (c) The installation shall not adversely affect drinking water:
 - (i) by materials in contact with the water being unsuitable for the purpose;
 - (ii) as a result of backflow of water from water fittings, or water using appliances into pipe work connected to mains or to other fittings and appliances;
 - (iii) by cross-connection between pipes conveying water supplied by the water undertaker with pipes conveying water from some other source; and
 - (iv) by stagnation, particularly at high temperatures.
- (d) No pump or similar apparatus, the purpose of which is to increase the pressure in or rate of flow from a supply pipe or any fitting or appliance connected to a supply pipe, shall be connected unless the prior written permission of the water supplier has been obtained in each instance. The use of such a pump or similar apparatus is likely to lead to pressure reduction in the upstream pipe work which, if significant, increases the risk of backflow from other fittings.
- (e) The water shall not come in contact with unsuitable materials of construction.

-
- (f) No pipe or fitting shall be laid in, on or through land fill, refuse, an ash pit, sewer, drain, cesspool or refuse chute, or any manhole connected with them.
- (g) No pipe susceptible to deterioration by contact with any substance shall be laid or installed in a place where such deterioration is likely to occur. No pipe that is permeable to any contaminant shall be laid or installed in any position where permeation is likely to occur.
- (h) If a liquid (other than water) is used in any type of heating primary circuit, which transfers heat to water for domestic use, the liquid shall be non-toxic and noncorrosive.
- (i) A backflow prevention device shall be arranged or connected at or as near as practicable to each point of delivery and use of water. Appliances with built-in backflow prevention shall be capable of passing the test. All backflow prevention devices shall be installed so that they are accessible for examination, repair or replacement. Such devices shall be capable of being tested periodically by the Authority to ensure that the device is functioning efficiently and no backflow is occurring at any time.

5.16 Laying of Pipes on Site

5.16.1 Excavation of Trenches and Refilling

- (a) The bottoms of the trench excavations shall be so prepared that the barrels of the pipes, when laid, are well bedded for their whole length on a firm surface and are true to line and gradient.
- (b) In the refilling of trenches, the pipes shall be surrounded with fine selected material, well rammed so as to resist subsequent movement of the pipes.
- (c) No stones shall be in contact with the pipes; when resting on rock, the pipes shall be bedded on fine selected material or (especially where there is a steep gradient) on a layer of concrete.
- (d) The width of excavation trench shall be at least 0.4 m more than the outside diameter of the pipe.
- (e) The depth of ground cover shall be at least 0.9 m under roadway or 0.75 m under garden from the top surface of the pipe to the ground surface.
- (f) The bottom of the trench shall be carefully prepared so that the pipe will be bedded well for its entire length on firm surface.

5.16.2 Laying of Pipe

- (a) The pipes shall be carefully cleared of all foreign matter before being laid.
- (b) In sloping ground, the pipe laying shall proceed in upward direction. The pipe shall be provided with anchor blocks to withstand hydraulic pressure.

5.16.3 Laying of Pipe Through Ducts, Chases, Notches or Holes

Provisions for laying pipes in ducts or chase shall be made during the time of construction. When these will be cut into existing walls, they shall be large enough with smooth finishing for fixing the pipe and to accommodate thermal expansion. Piping subject to external pressure shall not be laid in notches or holes.

5.16.4 Lagged Piping

Lagged piping shall be entirely covered with waterproof and fire insulating materials before their attachment to the walls outside the building and shall be anchored with the wall keeping a gap in between the wall and the piping.

5.16.5 Jointing of Pipes

All joints and connections shall be gas tight and water tight for the pressure required by the test in accordance with Sec 5.22.2. The joints between different piping and fittings for water supply shall conform to the standards cited against them in Table 8.5.13. The requirements for the joints not specified in the table shall be subject to the approval of the Authority.

5.16.6 Special Care for Rat Proofing

The location and installation of water meter box shall be such as not to permit the entrance of rats into the building. The openings through walls, floors or ceilings for the installation of piping shall be closed by using proper collars to prevent the entrance of rats.

Table 8.5.13: Joints between Different Piping and Fittings

Material	Standard
ABS plastic pipe and fittings	ASTM D2235, ASTM D2661, ASTM D3139, ASTM F628 ASME B1.20.1
Asbestos, cement pipe and fittings	ASTM D1869
Brass pipe and fittings	ASME B1.20.1
Cast iron pipe and fittings	ASTM C564
Copper and copper alloy pipe and fittings	ASTM B32, ASME B1.20.1
PVC plastic pipe and fittings	ASTM D2846, ASTM D3139, ASTM F493, ASME B1.20.1
Galvanized steel pipe and fittings	ASME B1.20.1
PB plastic pipe, tubing and fittings	ASTM D2657, ASTM D3140, ASTM D3309
PE plastic pipe, tubing and fittings	ASTM D2657
PVC plastic pipe and fittings	ASTM D2564, ASTM D2855, ASTM D3139, ASTM D3212, ASTM F402, ASTM F656, ASME B1.20.1

5.17 Hangers and Support

The piping system shall be installed with proper hangers and support to minimize undue strains and stresses.

All fixtures and fittings shall be provided with hangers and support to secure them properly.

5.17.1 Galvanic action

Hangers, anchors and strapping materials shall be strong and ductile and shall not promote galvanic action.

5.17.2 Hanger Spacing

Vertical and horizontal piping shall be supported in accordance with Table 8.5.14.

Table 8.5.14: Hanger Spacing

Piping Material	Max. Horizontal Spacing (m)	Max. Vertical Spacing (m)
Galvanized steel pipe	3.5	4.5
Copper pipe or copper-alloy tubing > 38 mm diameter	3.5	3.0
Copper pipe or copper-alloy tubing < 38 mm diameter	2.0	3.0
PVC pipe and tubing	1.0	1.0
Aluminum tubing	3.0	4.5
Brass pipe	3.0	3.0

5.18 Protection of Potable Water Supply

5.18.1 Cross-connection

Potable water supply system shall be protected against non-potable water sources or wastes (solid, liquid or gases). There shall be no cross-connection between potable water distribution system and non-potable water distribution or waste disposal system.

5.18.2 Submerged outlet

From potable water supply system shall be avoided. Connection of potable water to boiler feed water system, or heating or cooling system shall be made through proper air gap.

5.18.3 Cooling water

Water used for cooling or for other purposes shall not be returned to the potable water supply system.

5.18.4 Back flow

Potable water supply system shall be protected against backflow either by air gap or by back flow preventer. Reflex non-return valve shall not be used for this purpose. Details are explained in Sec 5.15.2.

5.18.5 Back flow Protections

The connection of potable water for health care plumbing fixtures shall be protected against backflow in accordance with Table 8.5.15.

5.18.6 Air Gap

The minimum air gaps for different water supply openings or outlet shall be at least 3 times the effective opening when they will be placed close to a wall. The minimum air gaps shall be at least 2 times the effective opening when they will be located away from a wall.

5.18.7 Potable water supply connection to any cistern or apparatus containing chemical(s) shall be done only with the special approval for such connection by the Authority and shall be marked by a tag.

5.18.8 All piping and fitting shall be designed, installed and maintained as to be and to remain completely air-tight and thereby avoiding waste of water, damage to property and to avoid the risk of contamination.

5.18.9 Non-potable water supply system shall have to be painted and marked by a tag.

5.18.10 Flushing valve operated water closets when installed in any building shall be supplied through a separate branch pipe with a back flow preventer at the starting point where the branch pipe is taken off from the supply pipe.

Table 8.5.15: Water Supply Protection for Hospital Fixtures

Fixtures	Protections Required
Aspirators	Vacuum breaker
Bedpan washer	Vacuum breaker
Boiling type sterilizer	Air gap
Exhaust condenser	Vacuum breaker
Flush floor drain	Vacuum breaker
House connection	Vacuum breaker
Pressure sterilizer	Vacuum breaker
Vacuum system (cleaning and fluid section)	Air gap or vacuum breaker

5.19 Health Care Water Supply

5.19.1 General Requirement

All hospitals shall have at least two service pipes from the individual water supply source or from the water main for supplying water without any interruption. For roof storage system, the hospital shall have at least two storage tanks such that each of them is capable of serving the water distribution system in absence of the other. All special fixtures shall be installed without interference to transportation and the safety of patient and staff.

5.19.2 Hot Water Supply

All hospitals shall be equipped to supply hot water as required by different fixtures and equipment.

5.19.3 Water Supply Protection

The water supply connection to all special equipment or fixtures shall be protected against backflow, flooding, fouling and contamination of water supply system in accordance with Sec 5.9.

5.20 Cleaning and Disinfecting the System

5.20.1 General

The new and repaired potable water supply system including storage tank shall be disinfected before their use. The existing water supply system shall be cleaned and disinfected depending upon the quality of water. The storage tank shall be cleaned and disinfected at least once a year.

5.20.2 Disinfection Procedure

The following procedure may be adopted to disinfect the plumbing system:

- (a) The water supply system or storage tank shall be flushed with potable water until clean water appears at the outlets.
- (b) The system or part thereof which requires disinfection shall be filled up with chlorinated water containing 50 mg/l of chlorine for 24 hours or for 3 hours with a chlorinated water of chlorine concentration of 200 mg/l.
- (c) After the period of disinfection, the system shall be flushed with potable water until the chlorine is completely removed from the water in the system.
- (d) The above procedure shall be repeated until the bacteriological examination shows presence of no water contamination within the system.

5.21 Inspection, Testing and Completion Certificate

5.21.1 Inspection

Piping and joints shall not be enclosed, concealed or covered until they have been inspected and approved by the Authority. All piping and fixtures shall be inspected for satisfactory supports and protection from damage and corrosion.

5.21.2 Testing

After installation of the entire water supply system or part thereof, it shall be tested and approved by the Authority before its use.

- (a) Testing of Water Mains: The section of the main to be tested shall be charged with water carefully by providing a 25 mm inlet with a stop cock to expel all air from the main. The main shall be allowed to stand full of water for a few days. After that the mains shall be tested to a pressure of 500 kPa or double the maximum working pressure, whichever is greater for at least 5 minutes. The system shall be able to maintain the above test pressure.
- (b) Testing of Distribution Pipes and Fixtures: The distribution system to be tested shall be slowly and carefully charged with water to expel all air from the system and to avoid all shocks and water hammer. The piping and fittings shall be absolutely water tight when all draw off taps are closed. The system shall be able to maintain the pressures and flow required under working conditions.
- (c) Testing of Hot Water System: The entire hot water system shall be tested for the maximum rated temperature and pressure of hot water storage system. The system shall be able to maintain the required test pressure. All safety devices shall be tested for their proper operation.

5.21.3 Completion Certificate

The licensed plumber shall issue completion certificate in a prescribed form (Appendix N) to the Authority on completion of the water supply system or part thereof for inspection and testing. After testing, the Authority will allow the water connection from the water main (if any) and give the final approval (Appendix N) to use the system.

5.22 Guide to Maintenance

The owner or his/her designated agent shall maintain the water supply system in a safe operating condition as specified by the Code.

5.22.1 Frequency of Cleaning

The storage tank shall be inspected regularly and shall be cleaned and disinfected periodically. Metal tanks showing the sign of corrosion shall be coated as specified in Sec 5.9.2.2.

5.22.2 Over flow Pipe

The overflow pipes of storage tank shall be inspected regularly to keep the flow free from obstruction.

5.22.3 Water Quality

A periodical examination of water quality may be made.

5.23 Individual Water Supply System**5.23.1 General**

In the absence of a public water supply, the individual potable water source shall be used to supply water in a distribution system. The following water sources may be used for individual water supply purposes: drilled well, dug well, driven well, spring, infiltration gallery.

5.23.2 Water Requirements

The capacity of source shall be sufficient to supply water as specified in Sec 5.5.

5.23.3 Quality of Water

Water from developed well or cistern shall meet the potable water quality standard requirements specified by the Department of Environment, Bangladesh.

5.23.4 Chlorination

The well or cistern shall be chlorinated after their construction or repair.

5.23.5 Location of Water Source

The minimum distance of water source and pump suction line from potential sources of contamination shall be in accordance with Table 8.5.16.

Table 8.5.16: Distance from Potential Sources of Contamination

Potential Source of Contamination	Distance (m)
Pump floor drain of cast iron, draining to ground surface	1
Sewer	3
Farm silo	8
Septic tank	8
Subsurface pit/Seepage pit	15
Subsurface disposal field	15
Barnyard	30
Pasture	30

5.23.6 Well Construction**5.23.6.1 Location of water table**

The individual water supply shall not be developed from a water bearing stratum with water table at a depth less than 3 m below the ground surface.

5.23.6.2 Outside casing

The outside watertight casing shall have to be installed for each well up to a depth of at least 3 m below the ground surface and shall project at least 150 mm above the ground surface. The lower end of the casing shall be sealed in an impermeable stratum or extend into the water bearing stratum. The size of the casing shall be large enough to permit the installation of an independent drop pipe. The casing may be of concrete, tile, or galvanized or corrugated metal pipe. The annular space between the casing and the earth shall be filled with grout to a minimum depth of 3 m. For flood prone regions, top of the casing or pipe sleeve shall be at least 300 mm above the flood level.

5.23.6.3 Well cover

All potable wells shall be equipped with a watertight cover overlapping the top of the casing or pipe sleeve. For dug or bored well, the overlap and downward extension of the cover shall be at least 50 mm outside the well casing or well. The annular space between the casing or pipe sleeve and the drop pipe shall have a watertight sealing.

5.23.6.4 Drainage from well platform or pump house

The construction of well platform or pump house shall be such that this will drain away from the well by gravity.

5.23.7 Pumping Equipment

The design, installation and construction of pumps shall be such that they will not permit the entrance of any contaminating material into the well or water supply system. The pump shall be accessible for inspection, maintenance and repair.

5.24 List of Related Appendices

Appendix M	Application for Permit to Construct Water Supply and Distribution System
Appendix N	Completion Certificate (Water Supply Works)
Appendix O	Sizing of Cold Water Supply and Distribution Piping
Appendix P	Recommended Water Quality for Domestic Purposes.

PART VIII
Chapter 6
Sanitary Drainage

6.1 Purpose

The purpose of this Chapter is to set forth provisions for planning, design and installation of waste disposal systems in and out of buildings

6.2 Scope

6.2.1 This Chapter specifies the general requirements for environmental sanitation for different categories of buildings according to their occupancy classification.

6.2.2 This Chapter also covers the design, installation and maintenance of drainage systems together with all ancillary works such as manholes and inspection chambers used within the building and from the building to public sewers or to offsite waste disposal system (i.e. into septic tanks and seepage pits or subsurface drainage system).

6.2.3 The disposal of wastes from industries, nuclear plants, slaughter houses, etc. are not covered by this Code. These wastes shall be properly treated as specified by environmental quality standards of Bangladesh before their disposal into public sewers or into natural bodies of water.

6.3 Terminology

This Section provides an alphabetical list of all terms used and applicable to this Chapter of the Code. In case of any conflict or contradiction between a definition given in this Section and that in any other Chapter or Part of the Code, the meaning specified in this Chapter shall govern for interpretation of the provisions of this Chapter.

BEDDING FACTOR	The ratio of the product of design load and factor of safety to the minimum crushing strength.
BRANCH	Any part of the piping system other than a main, riser, or stack.
BRANCH INTERVAL	The length of soil or waste stack corresponding in general to a storey height, but in no case less than 2.5 m within which the horizontal branches from one floor or storey of building are connected to the stack.
BRANCH VENT	The vent connecting one or more individual vents with a vent stack or stack vent.
BUILDING DRAIN	The building (house) drain is that part of the lowest piping or open channel of a drainage system which receives the discharges from soil, waste, and other drainage systems inside the walls of the building and conveys the same to the building (house) sewer, beginning at 0.9 m outside the building wall.

BUILDING SEWER	The building (house) sewer is that part of the horizontal piping of a drainage system which extends from the end of the building drain and which receives the discharge of the building drain and conveys it to a public sewer, private sewer, individual sewage disposal system, or other point of disposal. Also known as SEWER.
CIRCUIT VENT	Venting of branch drainage pipe with which multiple fixtures are connected in battery.
DRAIN	A drain is any pipe or open channel which carries waste water or waterborne wastes in a building drainage system.
DRAINAGE SYSTEM	A drainage system (drainage piping) includes all the piping within public or private premises, which conveys sewage, rain water, or other liquid wastes to a legal point of disposal, but does not include the mains of a public sewer system or a private or public sewage treatment or disposal plant.
DRINKING FOUNTAIN	A fountain or a tap with potable water supply connection.
EXISTING WORK	The existing work is a plumbing system or any part thereof which was installed prior to the date of enforcement of this Code.
FIXTURE UNIT	A fixture unit is a quantity in terms of which the load producing effects on the plumbing system of different kinds of plumbing fixtures are expressed on some arbitrarily chosen scale.
FLUSH VALVES	A flush valve is a device installed on the fixtures for the purpose of flushing those fixtures.
FRENCH DRAIN	A shallow trench filled with coarse rubble, clinker or similar material with or without field drain pipes.
GRADE	The grade is the slope or fall of a pipe in reference to a horizontal plane. In drainage it is usually expressed as the fall in mm per m length of pipe.
HORIZONTAL BRANCH	A horizontal branch is a drain pipe extending laterally from a soil or waste stack or building drain, with or without vertical sections or branches, which receives the discharge from one or more fixture drains and conducts it to the soil or waste stack or to the building drain.

HORIZONTAL PIPE	A horizontal pipe is any pipe or fitting which is installed in a horizontal position or which makes an angle of less than 45° with the horizontal.
IMHOFF TANK	These are two-storeyed settling cum digestion tanks used for primary treatment of domestic sewage in a very anaerobic environment.
INDIVIDUAL VENT	An individual vent is a pipe installed to vent a fixture trap and which connects with the vent system above the fixture served or terminates in the open air.
INTERCEPTOR	An interceptor is a device designed and installed so as to separate and retain deleterious, hazardous, or undesirable matter from normal wastes and permit normal or liquid wastes to discharge into the disposal terminal by gravity.
INVERT	The lowest point of the internal surface of a pipe or channel at any cross-section.
KITCHEN SINK	Sink or washing facilities raised above or at the level of the floor fitted with a tap.
LEADER	A vertical drainage pipe that carries rainwater from roof or gutter drain to building storm drain or building drain or private disposal system. Also called Rainwater Down Pipe (RDP)
LIQUID WASTE	The liquid waste is the discharge from any fixture, appliance, or appurtenance in connection with a plumbing system which does not receive faecal matter.
LOAD FACTOR	The load factor is the percentage of the total connected fixture unit flow rate which is likely to occur at any point in the drainage system. It varies with the type of occupancy, the total flow unit above the point being considered, and with probability factor of simultaneous use.
LOCAL VENT STACK	A vertical piping to which connections are made from discharge side of traps and through which vapour or foul gas is removed from the fixture or device used on bedpan washer.
LOOP VENT	Also called Circuit vent. See CIRCUIT VENT.
MAIN	The main of any system of continuous piping is the principal artery of the system, to which branches may be connected.

MAIN SEWER	See Public Sewer.
MAIN VENT	The main vent is the principal artery of the venting system, to which vent branches are connected.
MANHOLE	An opening through which a man may enter or leave a drain, a sewer or other closed structure for inspection, cleaning and other maintenance operations, fitted with a cover.
MANHOLE CHAMBER	A chamber constructed on a drain or sewer so as to provide access thereto for inspection, testing or the clearance of obstruction.
NON SERVICE LATRINE	A latrine other than service latrine.
OFFSET	An offset in a line of piping is a combination of elbows or bends which brings one section of the pipe out of line but into a line parallel with the other section.
PIPE SYSTEM	<p>The system to be adopted will depend on the type and planning of the building in which it is to be installed and will be one of the following :</p> <p>(a) Single Stack System (Sec 6.9.3): One pipe system without trap ventilation pipe work.</p> <p>(b) One Pipe System (Sec 6.9.3): The plumbing system in which the waste from sinks, bath rooms and wash basins, and soil pipe branches are all collected into one main pipe connected directly to the drainage system. Gully traps and waste pipes are completely dispensed with but all the traps of water closets, basins, etc. are completely ventilated to preserve the water seal.</p> <p>(c) Two Pipe System (Sec 6.9.3): A discharge pipe system comprising two independent discharge pipes, one conveying soil directly to the drain, and other conveying waste water to the drain through a trapped gully. The system may also require ventilating pipes.</p>
PLUMBING	The plumbing includes the practice, materials, and fixtures used in the installation, maintenance, extension, and alteration of all piping, fixtures, appliances, and appurtenances in connection with any of the following: sanitary drainage or storm drainage

	facilities, the venting system and the public or private water supply systems, within or adjacent to any building, structure, or conveyance; also the practice and materials used in the installation, maintenance, extension, or alteration of the storm water, liquid waste, or sewerage, and water supply systems of any premises to their connection within any point of public disposal or other acceptable terminal.
PLUMBING FIXTURES	The plumbing fixtures are installed receptacles, devices, or appliances which are supplied with water or which receive or discharge liquids or liquid borne wastes, with or without discharge into the drainage system with which they may be directly or indirectly connected.
PLUMBING SYSTEM	The plumbing system includes the water supply and distribution pipes, plumbing fixtures and traps, soil, waste and vent pipes, building drains and building sewers, including their respective connections, devices, and appurtenances within the property lines of the premises, and water treating or water using equipment.
PUBLIC SEWER	A common sewer directly controlled by public authority. Also known as MAIN SEWER.
RELIEF VENT	A relief vent is a vent the primary function of which is to provide circulation of air between drainage and vent systems (Sec 6.9.6).
RISER	A water supply pipe that extends vertically one full storey or more to convey water to branches or fixtures.
SANITARY SEWER	A sanitary sewer is a pipe which carries sewage and excludes storm, surface, and ground water. Also known as SEWER.
SEEPAGE PIT	See SOAK PIT.
SEPTIC TANK	A septic tank is a watertight settling tank which receives the discharge of a drainage system or part thereof and is designed and constructed so as to separate solids from the liquid, digest organic matter through a period of detention, and allow the liquids to discharge into the soil outside the tank through a system of open joint or perforated piping or disposal pit (Sec 6.9.13).
SERVICE LATRINE	A latrine from which the excreta are removed by manual agency and not by water carriage.
SEWAGE	The sewage is any liquid waste containing animal or vegetable matter in suspension or solution and may include liquids containing chemicals in solution.

SEWER	See BUILDING SEWER or PUBLIC SEWER or SANITARY SEWER or STORM SEWER.
SLUDGE	A settled portion of the sewage or waste water effluent from a sedimentation tank in semi-solid condition.
SOAK PIT	A pit, dug into permeable soil lined to form a covered perforated chamber or filled with sand at the bottom and gravel or broken bricks at the top into which effluent from septic tank or storm water is led and from which these may soak away into the ground. Also known as SEEPAGE PIT or SOAK WELL.
SOAK WELL	See SOAK PIT.
SOIL PIPE	A soil pipe is any pipe which conveys the discharge of water closets, urinals, or fixtures having similar functions, with or without the discharge from other fixtures, to the building drain or building sewer.
SOIL VENT	See Stack Vent.
STACK	A stack is the vertical main of a system of soil, waste, or vent piping.
STACK VENT	A stack vent (sometimes called a waste vent or soil vent) is the extension of soil or waste stack above the highest horizontal drain connected to the stack. Also known as SOIL VENT.
STACK VENTING	Stack venting is a method of venting a fixture or fixtures through the soil or waste stack.
STERILIZER VENT	A separate pipe or stack, indirectly connected to the building drainage system at the lower terminal, which receives the vapour from non-pressure sterilizers or the exhaust from pressure sterilizers and conduct the vapour directly to the outer air.
SUBSOIL DRAIN	A subsoil drain is a drain which receives only subsurface or seepage water and conveys it to a place of disposal.
SULLAGE	The discharge from wash basins, sinks and similar appliances, which does not contain human or animal excreta.
SUMP	A sump is a tank or pit which receives sewage or liquid waste, located below the normal grade of the gravity system, and which must be emptied by mechanical means.

SUPPORTS	The supports, hangers, and anchors are devices for supporting and securing pipe and fixtures to walls, ceilings, floors, or structural members.
TRAP	A trap is a fitting or device so designed and constructed as to provide, when properly vented, a liquid seal which will prevent the back passage of air or gas without materially affecting the flow of sewage or waste water through it.
TRAP SEAL	The trap seal is the maximum vertical depth of liquid that a trap will retain, measured between the crown weir and the top of the dip of the trap.
VENT PIPE	See Vent System.
VENT STACK	A vent stack is a vertical vent pipe installed primarily for the purpose of providing circulation of air to and from any part of the drainage system.
VENT SYSTEM	A vent system is a pipe or pipes installed to provide a flow of air to or from a drainage system or to provide a circulation of air within such system to protect trap seals from siphonage and back pressure. Also known as VENT PIPE.
VERTICAL PIPE	A vertical pipe is any pipe or fitting which is installed in a vertical position or which makes an angle of not more than 45° with the vertical.
WASTE PIPE	A waste pipe is a pipe which conveys only liquid waste free of faecal matter.
YOKE VENT	A yoke vent is a vent provided between drainage and vent stacks to provide circulation of air between drainage and vent systems (Sec 6.9.6).

6.4 Drainage and Sanitation Plans

6.4.1 Requirement of Permit

Drainage and sanitation system shall not be installed until a permit for such work has been issued by the Authority for existing (only for addition or for alteration) or new building or for any other premises.

6.4.2 Application for Permit

An application for a permit for drainage and sanitation work shall be made on a prescribed form (see Appendix Q) by the licensed plumber and the owner, or by his appointed person or agent to install all or a self-contained or workable part of such work. The application shall accompany building drainage plans and adequate description of the proposed drainage and sanitation installation in a drawing (drawn to a scale not less than 1:100) with the following details:

- (a) Plan(s) of the building with typical arrangement of plumbing fixtures
- (b) Sanitary waste disposal system
- (c) Venting system in the building drainage system
- (d) Materials, sizes and gradients of all proposed piping
- (e) Position of manhole, traps, waste pipe, rainwater pipe, vent pipe, water closet, urinal, lavatory, sink or other appliances in the premises and their connection with sewerage/drainage system or with private waste disposal system; the following colours may be used to indicate sewers, waste water pipes, rainwater pipes and existing works:

Proposed sanitary sewers and sanitary waste disposal pipes : Red

Proposed sanitary sewers and sanitary waste disposal pipes : Blue

Existing network : Black

- (f) Position of refuse chute, inlet hopper and collection chamber for high rise buildings.

6.4.3 In addition to drainage plan a separate site plan of the building shall be submitted with the following particulars:

- (a) Adjoining plots and streets with their identification
- (b) Position and invert level of the public sewers (if any) and the direction of flow in it
- (c) Level of the proposed drains connecting to the sewers (if any)
- (d) Position and layout of private waste disposal system (in absence of public sewers); and
- (e) Alignment, size and gradients of all drains.

6.4.4 For high rise buildings, design calculations and specifications for various items of the work involved shall be submitted along with the drawings.

6.4.5 Permits and Approvals

The building official shall examine or cause to be examined all applications for permits and, amendments thereto within 45 days. If the application does not conform to the requirements of all pertinent laws, such application shall be rejected in writing, stating the reasons therefore. If the proposed work satisfies all the Code requirements, the Authority shall issue a nontransferable permit.

6.5 Licensing of Plumber

6.5.1 License Requirement

No individual, partnership, corporation or firm shall engage in the business of installation, repair, alteration or maintenance of plumbing, drainage and sanitation work without obtaining a license from the Authority.

6.5.2 Examination and Certification

The Authority shall establish a plumber's examination board. The board will determine the requirements for the qualification and procedures for examination of applicants for license. The Authority will issue license to such applicants who meet the qualifications therefore and successfully pass the examination conducted by the board.

6.5.3 Annulment of License

The license of a licensed plumber may be nullified by the Authority, if it is proved that a plumbing work has been completed and certified by the licensed plumber violating the provisions of this Code deliberately setting aside the approvals given in the permit or without receiving the permit from the Authority.

6.6 Drainage and Sanitation Requirement

6.6.1 General

- (a) Each family dwelling unit on premises abutting a public sewer or with a private waste disposal system shall have at least one water closet and one kitchen sink or washing facilities. It is recommended to have at least one bathroom with a bath tub or shower to meet the basic requirements of sanitation and personal hygiene and in that case bath and water closet shall be separately accommodated.
- (b) All other structures for human occupancy or use on premises abutting a sewer or with a private waste disposal system shall have adequate sanitary facilities but in no case less than one water closet and one other fixture for cleaning purposes.
- (c) There shall be one water tap and arrangement for drainage in the vicinity of each water closet in all buildings.

- (d) There shall be at least one water tap and arrangement for drainage in the vicinity of each urinal or group of urinals in all buildings.
- (e) There shall be separate facilities for each sex for public toilets and for public bathing places based on the percentage of each anticipated sex.
- (f) Where drinking water fountain is provided, it shall not be installed in toilet room.
- (g) Rooms containing water closets or urinals shall be separated by partition wall from places where food will be prepared and served.
- (h) All water closets and urinals shall be provided with flushing system.

6.6.2 Minimum Number of Fixtures

Table 8.6.1, Sections 6.6.2.1 and 6.6.2.2 provide the minimum number of fixtures required for different categories of buildings according to their occupancy classifications. The fixture requirement for the occupancy not provided in these sections shall be subject to the approval of the Authority.

6.6.2.1 The size of drainage pipe of fixtures shall be provided as shown in Table 8.6.2.

6.6.2.2 Automatic clothes washers

Waste connection: The waste from an automatic clothes washer shall discharge through an air break into a standpipe in. The trap and fixture drain for an automatic clothes washer stand pipe shall be a minimum of 2 inches (50 mm) in diameter.

6.6.2.3 Floor drains

Floor drains shall have removable strainers. The floor drain shall be constructed so that the drain is capable of being cleaned. Access shall be provided to the drain.

6.6.2.4 Physically handicapped plumbing facilities

All buildings other than residential, educational, storage and hazardous according to building occupancy classification, having public toilet facilities with required number of fixtures shall have at least one water closet for each sex (or one unisex water closet facility) and one drinking fountain accessible to and usable by physically handicapped persons. The water closet compartment for physically handicapped persons shall be in accordance with Sec 6.9.4.

6.6.2.5 Drainage and sanitation requirements for traffic terminal stations

- (a) The minimum sanitary conveniences provided at any traffic terminal station like railway station, bus station etc. shall consist of non-service type latrines one for each sex, and one non-service type urinal for males for a daily passenger volume up to 300 persons. For large stations and airports, sanitary arrangements shall be in accordance with Table 8.6.1.

- (b) There shall be adequate arrangements for satisfactory drainage of all sewage, sullage and waste water. The drainage shall be so designed as to cause no stagnation at the maximum discharge rate for which the different units are designed.
- (c) Adequate scavenging arrangements shall be provided to keep the stations or terminals clear of all refuse. Refuse containers shall be placed at convenient points.

6.6.3 Accessibility

The fixtures specified in Sec 6.6.2 for public building shall be located not more than one floor above nor more than one floor below the floor occupied by the people for whose use the fixtures are intended, unless elevator service is available, except that in buildings which are accessible to the physically handicapped, there shall be minimum facilities as specified by the Code. It is desirable that the path of travel to the facilities shall not exceed a travel distance of 150 m.

Table 8.6.1: Plumbing Fixtures Requirement

Type of Building Occupancy	Water Closets*	Wash Basins ***	Bathtubs or Shower	Urinals** (For male)	Drinking Fountains	Other Fixtures
A Residential						
A1 Single Family Dwelling	1 per dwelling or apartment	1 per dwelling or apartment	1 per dwelling or apartment	-	-	1 kitchen sink per dwelling/apartment
A3 Flats or Apartments						
A2 Two Families Dwelling	2 per dwelling	2 per dwelling	2 per dwelling	-	-	2 kitchen sink per dwelling
A4 Mess, Boarding Houses and Hostels						
For residence and residential staff	MALE			1 per 25-150 Add 1 per additional 50	1 per 75	1 kitchen sink in each kitchen
	1 per 8	1 per 8	1 per 8			
	FEMALE					
	1 per 6	1 per 6	1 per 6			
For nonresidential staff	MALE		-	0 up to 6 1 per 7-20 2 per 21-45 3 per 46-70 4 per 71-100	1 per 100	-
	1 per 1-15	1 per 1-15				
	2 per 16-35	2 per 16-35				
	3 per 36-65	3 per 36-65				
	4 per 66-100	4 per 66-100				
	FEMALE					
	1 per 1-12	1 per 1-12				
2 per 13-25	2 per 13-25					
3 per 26-40	3 per 26-40					
4 per 41-57	4 per 41-57					
5 per 58-77	5 per 58-77					
6 per 78-100	6 per 78-100					

Type of Building Occupancy	Water Closets*	Wash Basins ***	Bathtubs or Shower	Urinals** (For male)	Drinking Fountains	Other Fixtures
Rooms wherein outsiders are received	MALE		-	1 per 50	-	-
	1 per 100 - 400 Add 1 per additional 250	1 per water closet and 1 per urinal or group of urinals				
	FEMALE					
	2 per 100- 200 Add 1 per additional 100.	1 per water closet				
A5 Hotels and Lodging Houses						
For residential public and staff	1 per 8 omitting the occupant of the room with attached water closet; Minimum of 2 if both sex are lodged.	1 per 10 omitting the wash basins installed in the room or suite.	1 per 10 omitting the occupants of the room with bath in suite.	-	1 per 100	1 kitchen sink in each kitchen
For public rooms	MALE		-	1 per 50	1 per 100	-
	1 per 100-400. Add 1 per additional 250 or part thereof.	1 per water closet and 1 per urinal or group or urinals				
	FEMALE					
	2 per 100-200. Add 1 per additional 100 or part thereof.	1 per water closet				
For nonresidential staff	MALE		-	0 up to 6 1 per 7-20 2 per 21-45 3 per 46-70 4 per 71-100	1 per 100	-
	1 per 1-15	1 per 1-15				
	2 per 16-35	2 per 16-35				
	3 per 36-65	3 per 36-65				
	4 per 66-100	4 per 66-100				
	FEMALE					
	1 per 1-12	1 per 1-12				
	2 per 13-25	2 per 13-25				
3 per 26-40	3 per 26-40					
4 per 41-57	4 per 41-57					
5 per 58-77	5 per 58-77					
6 per 78-100	6 per 78-100					

Type of Building Occupancy	Water Closets*	Wash Basins ***	Bathtubs or Shower	Urinals** (For male)	Drinking Fountains	Other Fixtures
B Educational Facilities						
B1 Education Facilities up to Higher Secondary Levels	BOYS		-	1 per 20	1 per 50	Service sink: 1 per floor.
	1 per 40	1 per 60 but minimum 2				
	GIRLS					
	1 per 25	1 per 40 but minimum 2				
B2 Facilities for Training and Above Higher Secondary Levels	MALE		-	1 per 20	1 per 50	Service sink: 1 per floor.
	1 per 30	1 per 40 but minimum 2				
	FEMALE					
	1 per 20	1 per 30 but minimum 2				
B3 Preschool Facilities	1 per 15 children	1 per 15 children	-	-	1 per 50 children	Service sink: 1 per floor
C Institution for Care						
C1 Institution for Care of Children	BOYS			Urinals may be provided in boys toilet rooms in lieu of water closets but for not more than ½ of the required number of water closets	1 per 50	Service sink: 1 per floor
	1 per 8	1 per 8	1 per 8			
	GIRLS					
	1 per 6	1 per 6	1 per 8			
C2 Custodial Institutions per Physically Capable Adults	1 unisex facility or 1 for each sex per 1-100	1 per 200	1 per 10 Minimum 1 for use by both sexes.	-	1 per 100	Service sink: 1 per floor
C3 Custodial Institution per the Incapable Adults	2 unisex facilities or 1 unisex facility and 1 for each sex per 100-200. Over 200 one additional unisex facility or 1 for each sex for each additional 100 .	1 per 200	1 per 10 Minimum 1 for use by both sexes.	-	1 per 100	Service sink: 1 per floor

Type of Building Occupancy	Water Closets*	Wash Basins ***	Bathtubs or Shower	Urinals** (For male)	Drinking Fountains	Other Fixtures
C4 Penal and Mental Institutions for Children	1 per cell	1 per cell	1 per 15 children	-	1 per 100 children	Service sink
C5 Penal and Mental Institutions for Adults	1 per cell	1 per cell	1 per 15	-	1 per 100	Service sink
D Health Care Facilities						
D1 Normal Medical Facilities (Indoor Patient Ward)	MALE			-	1 per 75 patients	Service sink: 1 per each ward. Bed pan washing sink: 1 for each ward. Kitchen sink: 1 per each kitchen
	1 per 8 patient	2 up to 30 patients and add 1 fixture per additional 30 patients	1 per 8 patients			
	FEMALE					
	1 per 8 patient	2 up to 30 patients and add 1 fixture per additional 30 patients	1 per 8 patients			
D1 Normal Medical Facilities (Outdoor Patient Ward)	MALE		-	1 per 50	1 per 500	Service sink: 1 per each ward
	1 per 100	1 per 100				
	FEMALE					
D2 Emergency Medical Facilities	2 per 100	1 per 100				
E Business						
E1 Offices E2 Research and Testing Laboratories E3 Essential Services	MALE		-	0 up to 6 1 per 7-20 2 per 21-45 3 per 46-70 4 per 71-100 Add@ 3% for 101-200 and @ 2.5% for over 200	1 per 100	Service sink: 1 per floor.
	1 per 25	1 per 25				
	FEMALE					
	1 per 15	1 per 25				

Type of Building Occupancy	Water Closets*	Wash Basins ***	Bathtubs or Shower	Urinals** (For male)	Drinking Fountains	Other Fixtures
F Mercantile						
F1 Small Shops and Markets F2 Large Shops and Markets	1 per 500	1 per 750	-	Urinals may be provided in toilet room in lieu of water closets per men but per not more than ½ of the required number of water closets.	1 per 1000	Service sink:1
F3 Refuelling Station	MALE		-	0 up to 6 1 per 7-20 2 per 21-45 3 per 46-70 4 per 71-100 Add@ 3% for 101-200 and @ 2.5% for over 200	1 per 100	Service sink: 1 per floor.
	1 per 25	1 per 25				
	FEMALE					
	1 per 15	1 per 25				
G Industrial Buildings						
G1 Low hazard industries G2 Moderate hazard industries	MALE		As required by particular trades or occupations	0 up to 6 1 per 7-20 2 per 21-45 3 per 46-70 4 per 71-100 Add @ 3% for 101-200 and @ 2.5% for over 200	1 per 100	Service sink: 1 per floor
	1 per 1-15 2 per 16-35 3 per 36-65 4 per 66-100	1 per 25				
	FEMALE					
	1 per 1-12 2 per 13-25 3 per 26-40 4 per 41-57 5 per 58-77 6 per 78-100	1 per 25				
H Storage Buildings						
H1 Low fire risk storage H2 Moderate fire risk storage	1 per 100	1 per 100	Provisions per emergency shower	-	1 per 1000	Service sink:1
I Assembly						
I1 Large assembly with fixed seats I2 Small assembly with fixed seats I3 Large assembly without fixed seats I4 Small assembly without fixed seats						

Type of Building Occupancy	Water Closets*	Wash Basins ***	Bathtubs or Shower	Urinals** (For male)	Drinking Fountains	Other Fixtures				
Mosque	1 per 30	-	1 per 100	-	1 per 100	Water taps with drainage arrangement: 1 per 10				
Junction Stations, Intermediate Stations, Terminal Stations and Bus Terminals	MALE		-	Min 2, 4 per 1000 Add 1 per additional 1000	1 per 300	Service sink: 1 per floor				
	Min 2, 4 per 1000 Add 1 per additional 1000.	Min 2, 4 per 1000 Add 1 per additional 1000								
	FEMALE									
	Min 2, 5 per 1000 Add 1 per additional 1000	Min 2, 6 per 1000 Add 1 per additional 1000								
Domestic Airport	MALE		-	1 Minimum 2 per 200 4 per 400 5 per 600 6 per 800 7 per 1000	1 per 300	Service sink: 1 per floor				
	2 Minimum 4 per 200 6 per 400 8 per 600 9 per 800 10 per 1000	2 Minimum 4 per 200 6 per 400 8 per 600 9 per 800 10 per 1000								
	FEMALE									
	2 Minimum 5 per 200 8 per 400 10 per 600 13 per 800 13 per 1000	2 Minimum 4 per 200 6 per 400 8 per 600 9 per 800 10 per 1000								
	MALE						4 shower stalls in the female or male toilet in the transit and departure lounge and also in the main concourse	8 per 200 22 per 600 22 per 1000	1 per 300	Service sink: 1 per floor
	6 per 200 12 per 600 18 per 1000	10 per 200 20 per 600 25 per 1000								
	FEMALE									
	10 per 200 20 per 600 29 per 1000	10 per 200 20 per 600 25 per 1000								
International Airport	MALE		4 shower stalls in the female or male toilet in the transit and departure lounge and also in the main concourse	8 per 200 22 per 600 22 per 1000	1 per 300	Service sink: 1 per floor				
6 per 200 12 per 600 18 per 1000	10 per 200 20 per 600 25 per 1000									
FEMALE										
10 per 200 20 per 600 29 per 1000	10 per 200 20 per 600 25 per 1000									

Type of Building Occupancy	Water Closets*	Wash Basins ***	Bathtubs or Shower	Urinals** (For male)	Drinking Fountains	Other Fixtures
Cinemas, Concert halls, Theatres (for public use)	MALE		-	1 per 25	1 per 500	Service sink 1
	1 per 100- 400 Add 1 per additional 250	1 per 200				
	FEMALE					
	3 per 100- 200 Add 2 per additional 100	1 per 200				
Cinemas, Concert halls, Theatres (for permanent employee use)	MALE		-	0 up to 6 1 per 7-20 2 per 21-45	1 per 500	-
	1 per 1-15 2 per 16-35	1 per 1-15 2 per 16-35				
	FEMALE					
	1 per 1-12 2 per 13-25	1 per 1-12 2 per 13-25				
Art Galleries, Libraries, Museums (for public use)	MALE		-	1 per 50	1 per 500	Service sink: 1
	1 per 200 - 400 Add 1 per additional 250	1 per 200 Over 200 add 1 per additional 250				
	FEMALE					
	1 per 100 - 200 Add 1 per additional 150	1 per 200 Add 1 per additional 150				
Art Galleries, Libraries, Museums (for permanent employee use)	MALE		-	0 up to 5 1 per 7-20 2 per 21-45	1 per 100	-
	1 per 1-15 2 per 16-35	1 per 1-15 2 per 16-35				
	FEMALE					
	1 per 1-12 2 per 14-25	1 per 1-12 2 per 14-25				
I5 Sports Facilities	MALE		1 per 50	1 per 75	1 per 300	Service sink: 1
	1 per 75	1 per 60				
	FEMALE					
	1 per 50	1 per 60				

Type of Building Occupancy	Water Closets*	Wash Basins ***	Bathtubs or Shower	Urinals** (For male)	Drinking Fountains	Other Fixtures
J Hazardous Buildings						
J1 Explosion hazard building	1 per 100	1 per 100	Provisions per emergency shower	-	1 per 1000	Service sink:1
J2 Chemical hazard building						
J3 Biological hazard building						
J4 Radiation hazard building						
K Garage						
K1 Parking garage	MALE		-	0 up to 6 1 per 7-20 2 per 21-45 3 per 46-70 4 per 71-100 Add@ 3% per 101-200 and @ 2.5% per over 200	1 per 100	Service sink: 1 per floor.
K2 Private garage	1 per 25	1 per 25				
K3 Repair garage	FEMALE					
	1 per 15	1 per 25				
L Utility						
L Utility	1 minimum	1 minimum	-	-	-	-
M Miscellaneous						
M1 Special structures****	-	-	-	-	-	-
M2 Fences, tanks and towers	-	1 minimum	-	-	-	-
<p>* Some of the water closets may be of European style. The water closet(s) shall not be oriented in the east-west direction.</p> <p>** The urinal(s) shall not be oriented in the east-west direction.</p> <p>*** Toilet(s) of public use shall have at least one water tap with adequate drainage arrangement per ablution purpose when the numbers of devotees exceed twenty.</p> <p>**** Plumbing fixture requirements for occupancy M1 shall be assessed considering its nature of use and the similarity in purpose with any of the occupancies mentioned above.</p>						

Table 8.6.2: Sanitary Appliance Minimum Internal Diameter of Waste Outlet (mm)

Soil appliances		Waste appliances	
(a) Indian and European type water closets	100	(a) Drinking fountain	25
(b) Bed pan washers and slop sinks	100	(b) Wash basin	32
(c) Urinal with integral traps	75	(c) Bidets	32
(d) Stall urinals (with not more than 50- 120 mm of channel drainage)	40	(d) Domestic sinks and baths	40
(e) Lipped small urinal	40	(e) Shower bath trays	40
		(f) Domestic bath tubs	50
		(g) Hotel and canteen sinks	50
		(h) Floor traps (outlet diameter)	65

6.7 Materials and Appliances

Different sanitary appliances, materials and fittings shall conform to the requirements of the Standards as provided in Tables 8.6.3 of this Chapter and Table 8.5.9 of Chapter 5 Part 8. For other appliances, materials and fittings that are not listed in the above mentioned Tables shall be subject to the approval of the Authority.

Table 8.6.3(a): Recommended Standards for Sanitary Appliances

Appliances	Standard	Appliances	Standard
Ceramic wash basin and pedestals	BDS 1162-87	Metal sink for domestic purpose	BS 1244
Ceramic wash down water closet pans	BS 1213	Urinals (bowl type) vitreous china	BDS 1163-87 part 1, 3
Foot rest vitreous china	BDS 1163-87 part 1, 4	Wash-down water closet pans, vitreous china	BDS 1163-87 part 1, 2
Integrated squatting pans vitreous china	BDS 1163-87 part 1, 5	Water closet seat plastic	BS 1254
Metal hand rinse basin	BS 1329	Water closet flushing cisterns and pipes	BS 1125

Table 8.6.3(b): Recommended Standards for Building Drainage and Vent Pipe

Material	Standards
Acrylonitrile butadiene styrene (ABS plastic pipe)	ASTM D2661, ASTM F 628
Aluminum tubing	ASTM B429, ASTM B745M
Brass pipe	ASTM B43
Cast iron pipe	ASTM A74
Copper or Copper-alloy tubing	ASTM B75M, ASTM B88M, ASTM B251M, ASTM B306
Galvanized steel pipe	ASTM A53
Polyvinyl chloride plastic pipe	ASTM D2665, ASTM D2949, ASTM F891

Table 8.6.3(c): Recommended Standards for Building Sewer or Building Storm Sewer Pipe

Material	Standards
Acrylonitrile butadiene styrene (ABS plastic pipe)	ASTM D2261, ASTM D2751, ASTM F628, ASTM D2321
Bihuminized fibre pipe	ASTM D1861, ASTM D1862
Cast iron pipe	ASTM A74
Concrete pipe	ASTM C14M, ASTM C76M
Copper or Copper-alloy tubing	ASTM B75, ASTM B88M, ASTM B251M
Unplasticized Polyvinyl chloride (uPVC) plastic pipe	ASTM D2665, ASTM D2949, ASTM D3034, ASTM D2321, ASTM F891
Vitrified clay pipe	ASTM C4, ASTM C700

Table 8.6.3(d): Recommended Standards for Subsoil Drainage Pipe

Material	Standard
Bituminous fibre pipe	ASTM D2311
Cast iron pipe	ASTM A74
Concrete pipe	ASTM C654 M
Polyethylene (PE) plastic pipe	ASTM F405
Unplasticized Polyvinyl chloride (uPVC) plastic pipe	ASTM D2729, ASTM F891
Vitrified clay pipe	ASTM C4, ASTM C700

Table 8.6.3(e): Recommended Standards for Joints between Different Pipes and Fittings

Material	Standard
ABS plastic pipe and fittings	ASTM D2235, ASTM D2661, ASTM D3212, ASTM F628 ASME B1.20.1
Aluminium tubing	ASTM C564
Asbestos cement pipe and fittings	ASTM D1869
Brass pipe and fittings	ASME B1.20.1
Cast iron pipe and fittings	ASTM C564
Concrete pipe and fittings	ASTM C443
Copper or Copper-alloy pipe and fittings	ASTM B32, ASME B1.20.1
Copper-alloy tubing and fittings	ASTM B32
CPVC plastic pipe and fittings	ASTM F493, ASME B1.20.1
Galvanized steel pipe and fittings	ASME B1.20.1
PE plastic pipe and fittings	ASTM D2657
PVC plastic pipe and fittings	ASTM D2657, ASTM D2855, ASTM D3139, ASTM D3212, ASTM F402, ASTM F656, ASME B1.20.1
Vitrified clay pipe and fitting	ASTM C425

6.8 Hangers and Support and Pipe Jointing

6.8.1 Hangers and Support

The piping, fixtures and equipment used for plumbing, water supply and drainage system shall be provided with hangers and support in accordance with Sec 5.13 in Chapter 5.

6.8.2 Pipe Joints

The joints between different piping and fittings shall conform to the standards cited against them in Table 8.6.3. The requirements for the joints not specified in the table shall be subject to the approval of the Authority.

6.9 Design Considerations

6.9.1 Objective

For the design of drainage and sanitation system of different buildings according to building classification, the objective shall be to safeguard against fouling, deposition of solids and clogging and with adequate cleanouts and inspection chambers so arranged that the drains may be readily cleaned without the risk of health hazard.

6.9.2 General

- (a) The plumbing system shall be designed and adjusted to use the minimum quantity of water consistent with proper performance and cleaning.
- (b) Plumbing fixtures, devices and appurtenances shall be supplied with required volume of water at pressures adequate to enable these to function properly and without undue noise under normal conditions of use.

6.9.3 Different Building Drainage Systems

For the design and installation for drainage piping, one of the following building drainage systems shall be adopted: (i) single stack system; (ii) one-pipe system, and (iii) two-pipe system.

- (a) Single stack system may be used with 100 mm diameter stack for buildings up to 5-storey height. The fixtures in each floor shall be connected to a single stack for increasing the rate of discharge in the downward direction. The recommended depth of water seal trap for different fixtures shall be in accordance with Table 8.6.4. There shall be at least 200 mm vertical distance between the waste branch and the soil branch connection, while the soil pipe will be connected to stack above the waste pipe. The size of soil branch shall not be less than 100 mm. The horizontal branch distance for fixtures from stack and bend(s) at the foot of stack to avoid back pressure as well as the vertical distance between the lowest connection and the invert of drain shall be as shown in Figure 8.6.1.
- (b) Where all types of waste from the building are desired to be discharged into a common sewer or into same waste disposal system, one pipe system may be used (Figure 8.6.2).
- (c) Where the sullage from kitchen and bath will be dealt with separately and where soil waste shall be discharged into septic tank or Imhoff tank, the two pipe system shall be used (Figure 8.6.3).

Table 8.6.4: Recommended Depth of Water Seal Trap for Different Fixtures

Fixture	Water Seal (mm)
Water Closets	50
Floor Traps	50
For Waste Branch of 75 mm diameter or More	40
For Waste Branch of Less Than 75 mm diameter	75

6.9.4 Water Closet Compartment for Physically Handicapped

6.9.4.1 Provision for Wheelchair Users

The water closet compartment for wheelchair users shall have at least the dimensions and fittings as shown in Figure 8.6.4.

6.9.4.2 Provision for Ambulant Disabled People

The minimum dimension for water closet compartment and the fittings for ambulant disabled people shall be as shown in Figure 8.6.5.

6.9.5 Installation of Drainage System

6.9.5.1 All plumbing fixtures shall be made of smooth and nonabsorbent materials, free from concealed fouling surfaces and may be located in ventilated enclosures.

6.9.5.2 Whenever possible, all drainage system shall be drained to the public sewer or private waste disposal system by gravity.

Horizontal drainage piping up to 75 mm diameter shall be installed with a fall of not less than 20 mm/m and for larger than 75 mm diameter the fall shall not be less than 10 mm/m. It is a good policy to design the system for the highest possible velocity. However, consideration should be given to the fact that the high velocities in pipes with slopes greater than 20 mm per m may cause self-siphoning of trap seal.

6.9.5.3 Where conditions do not permit building drains and sewers to be laid with a fall as great as that specified, a lesser slope may be permitted provided the computed velocity in the drains will not be less than 0.6 m per second. The maximum recommended velocity will be 2.5 m per second.

6.9.5.4 Soil pipe conveying any solid or liquid filth to a drain shall be circular with a minimum dia of 100 mm.

The waste branch from bath room, wash basin or sink shall be of 32 mm to 50 mm diameter and shall be trapped immediately beneath such wash basins or sink by an efficient siphon trap with adequate means of inspection and cleaning. The minimum recommended size of waste stack is 75 mm.

6.9.5.5 The soil and waste stack shall be continued upward undiminished in size 0.6 m above the roof surface when the roof will be used only for weather protection. Where the roof will be used for any purpose other than weather protection, the soil and vent stack shall run at least 2 m above the roof surface so that there shall be least possible nuisance.

6.9.5.6 Soil and waste stack shall be firmly attached to the wall with a minimum clearance of 25 mm from wall.

All soil, waste, vent (ant siphoning) stacks shall be covered on top with cowl of same pipe material.

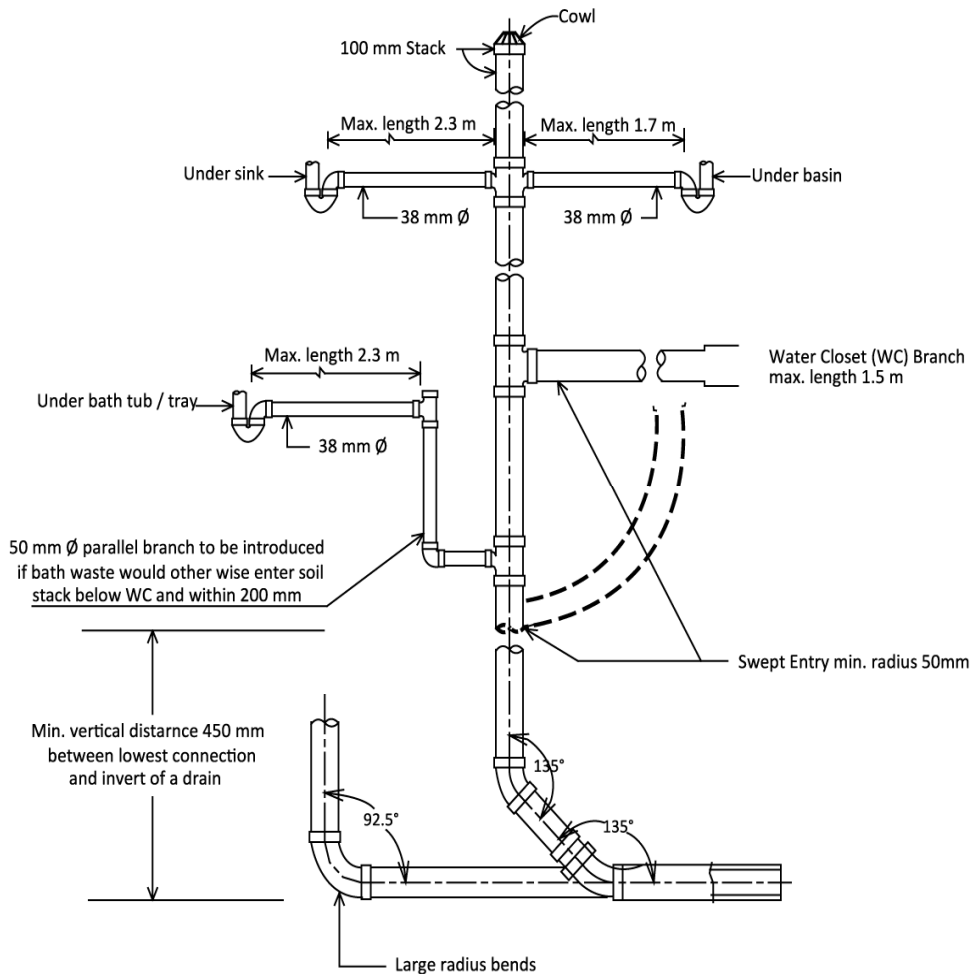


Figure 8.6.1 Single stack system

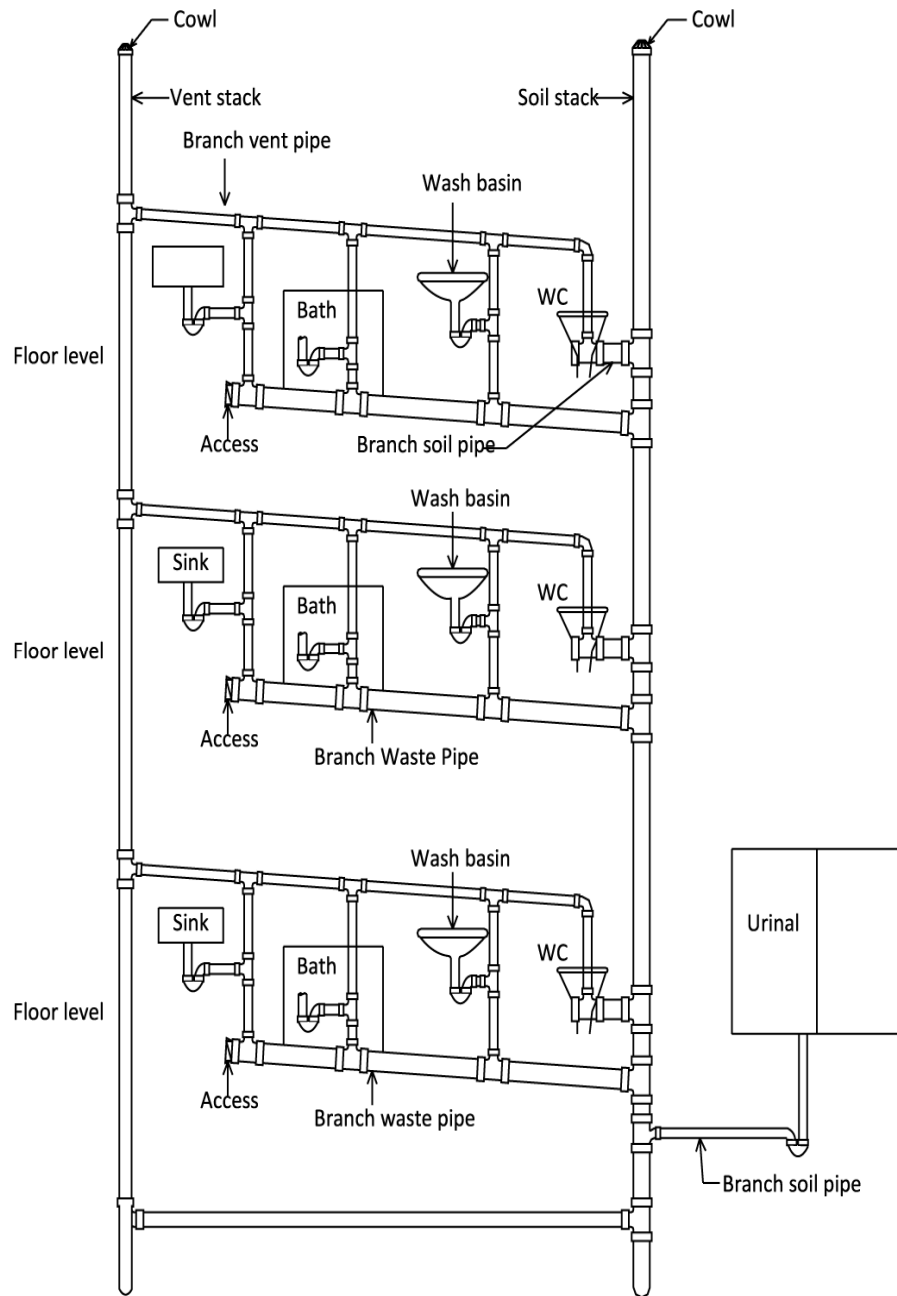


Figure 8.6.2 Diagram of one - pipe system

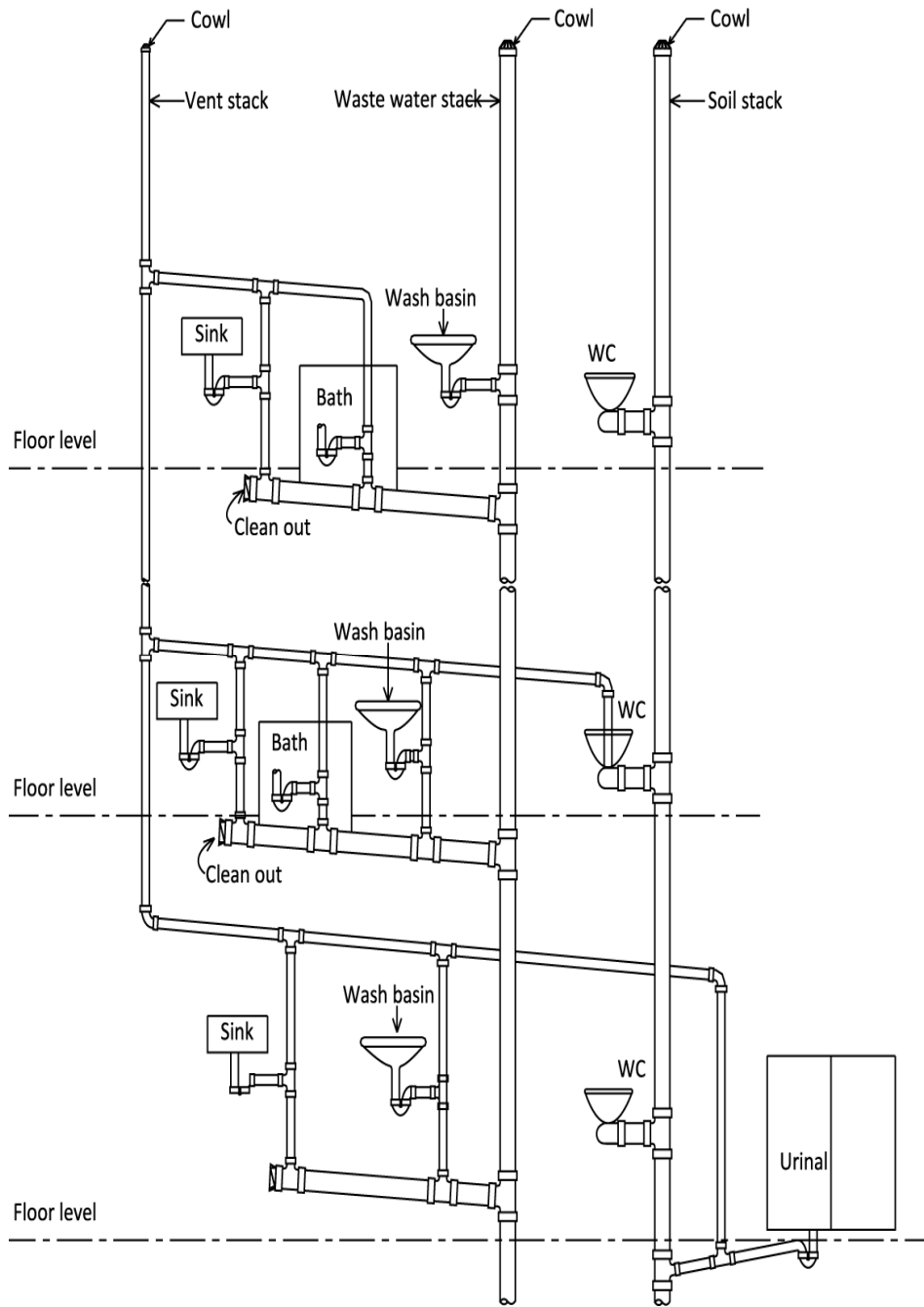


Figure 8.6.3 Diagram of two pipe system

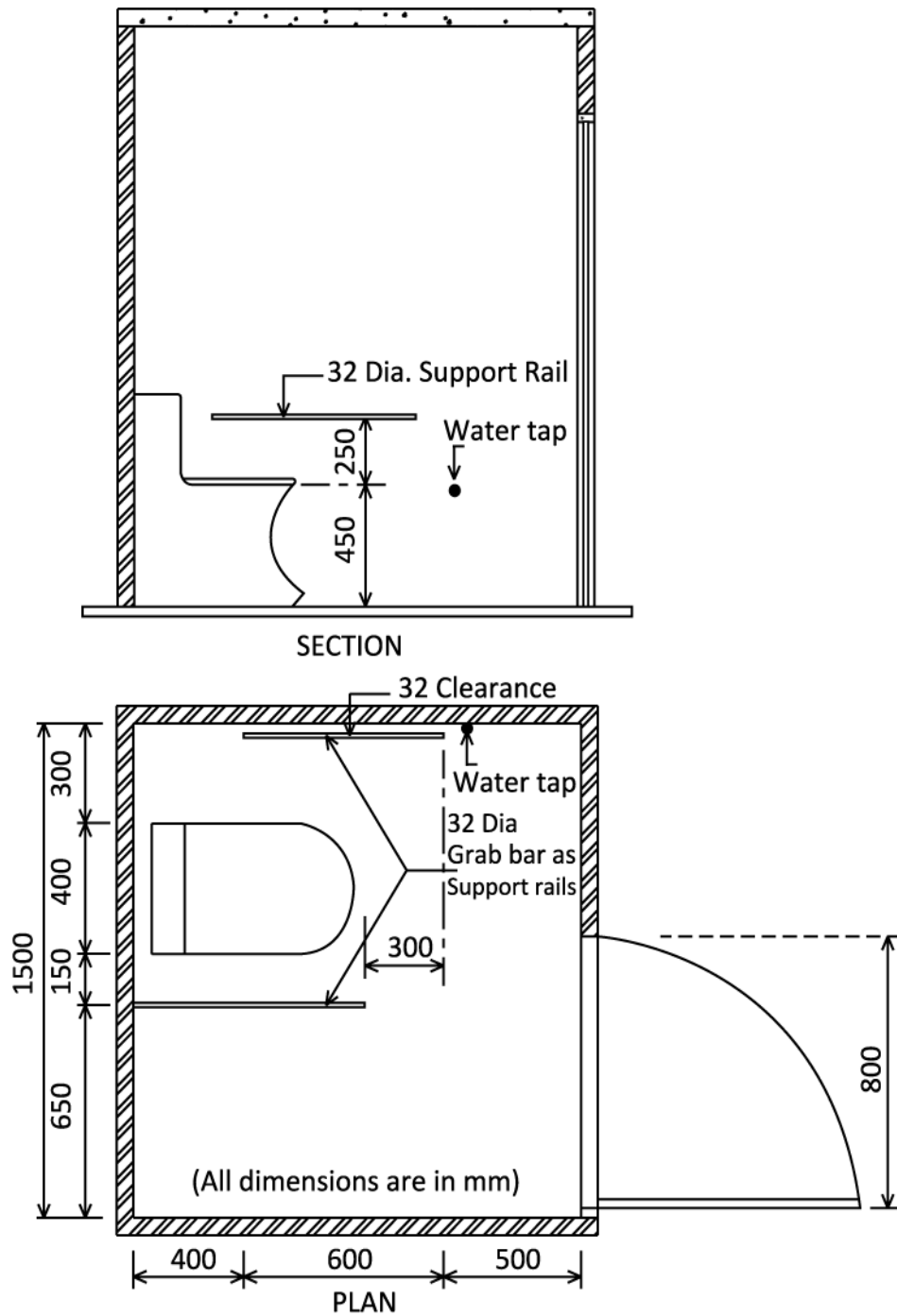


Figure 8.6.4 Water closet compartment for wheelchair user

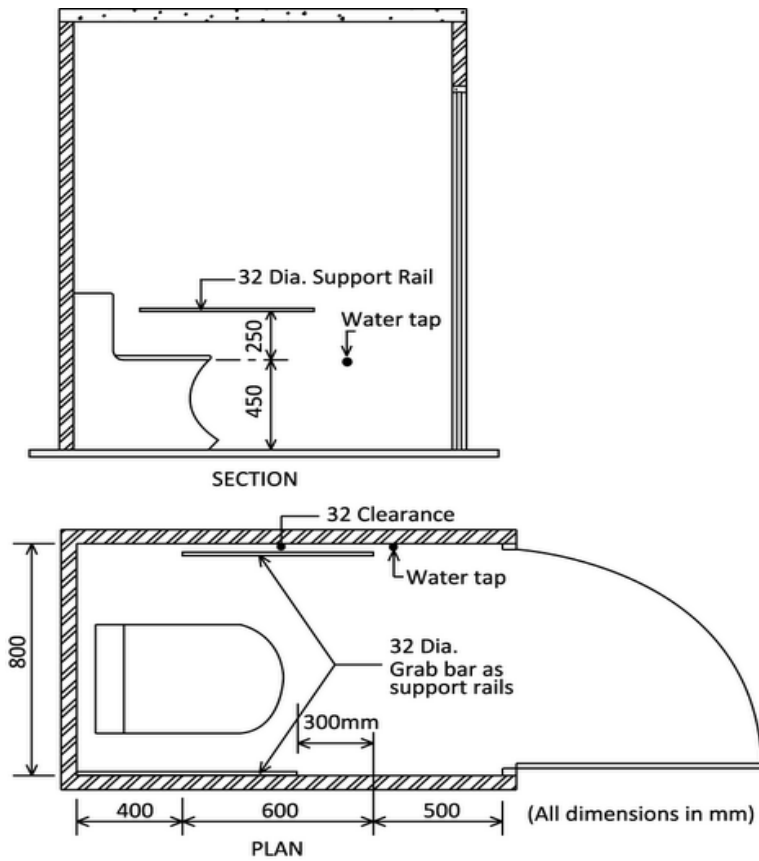


Figure 8.6.5 Water closet stall for ambulant disabled people

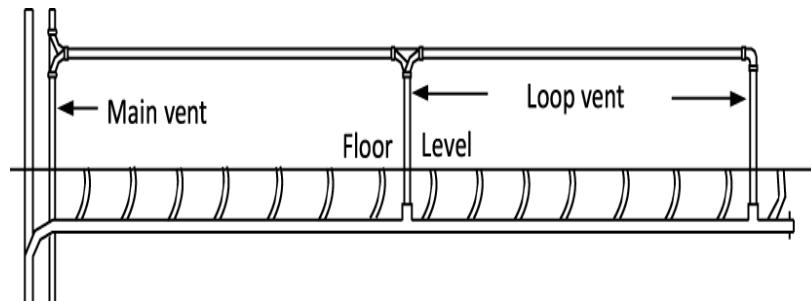


Figure 8.6.6 Circuit vent for a battery of water closets

6.9.6 Installation of Venting System

6.9.6.1 The vent stack or main vent shall be installed in conjunction with a soil or waste stack in a building. One vent stack may serve not more than two soil or waste stacks.

6.9.6.2 Ventilating pipes should be so installed that water cannot be retained in them. They should be fixed vertically. Whenever possible, horizontal runs should be avoided. Ventilating pipe shall be carried to such a height and in such a position as to afford by means of the open end of such pipe or vent shaft, a safe outlet for foul air with the least possible nuisance.

6.9.6.3 The building with building drain shall have at least one 100 mm vent stack or stack vent carried full size to outdoor air above the roof in accordance with Sec 6.9.5.7 above.

6.9.6.4 The diameter of a vent stack shall not be less than 50 mm.

6.9.6.5 The diameter of a branch vent pipe on a waste pipe shall not be less than 25 mm or two-thirds of the diameter of the branch waste pipe ventilated.

6.9.6.6 The branch vent pipe on a soil pipe shall not be less than 32 mm in diameter.

6.9.6.7 All main vents or vent stacks shall connect full size at their base to the building drain or to the soil or waste stack at or below the level of the lowest drainage connection to them. All vent stacks shall extend undiminished in size above the roof or shall be reconnected to a vent header or to the stack vent portion of the soil or waste stack, at least 150 mm above the flood level of the highest fixture connection discharging into the soil or waste stack. Where the roof is to be used for any purpose other than weather protection, the vent extension shall be in accordance with the Sec 6.9.5.7.

6.9.6.8 In case of offsetting of stacks a relief vent shall be provided at the base of upper stack just above the start of offset and at top of the lower stack portion just below the end of offset.

6.9.6.9 In high rise buildings yoke vent shall be provided at 10 storey intervals counting down from top.

6.9.6.10 In case huge number of fixtures are installed in battery to a single branch drainage pipe, circuit or loop vents shall be provided after 8 fixtures interval for 100 mm drain pipe and 24 fixtures interval for 150 mm drain pipe as shown in Figure 8.6.6

6.9.6.11 Offset in the stack vent portion of soil or waste stack, offset in vent stack and connection of vent stack at the bottom to soil or waste pipe or to the building drain shall be at an angle of at least 45° to the horizontal.

6.9.6.12 All vent and branch vent pipe shall be so graded and connected that sufficient slope is provided for condensation to drain back to soil or waste pipe by gravity.

6.9.6.13 Where fixtures, other than water closets discharge into the stack downstream of a water closet, each fixture connecting downstream shall be individually vented.

6.9.6.14 Soil and waste stacks in a building having more than 10 branch intervals shall be provided with a relief vent (Figure 8.6.7) at each tenth interval counting from the top floor.

6.9.6.15 In case the adjoining building is taller, the ventilating pipe shall be carried higher than the roof of the adjacent building, wherever it is possible.

6.9.6.16 The building drain intended for carrying waste water and sewage from a building shall be provided with at least one ventilating pipe situated as near as practicable to the building and as far away as possible from the point at which the drain empties in to the sewer or other earner.

6.9.7 Clearance of Blockages

6.9.7.1 There shall be sufficient and suitable access points at every change of alignment, gradient or diameter or at bends and junctions for clearing blockages from drains which cannot be reached by any other means.

6.9.7.2 In case of straight run of pipes, access points shall be provided at intervals of 15 meter.

Tables 8.6.5 and 8.6.6 show the maximum spacing and the recommended minimum dimensions for access fittings and chambers for the specified depth.

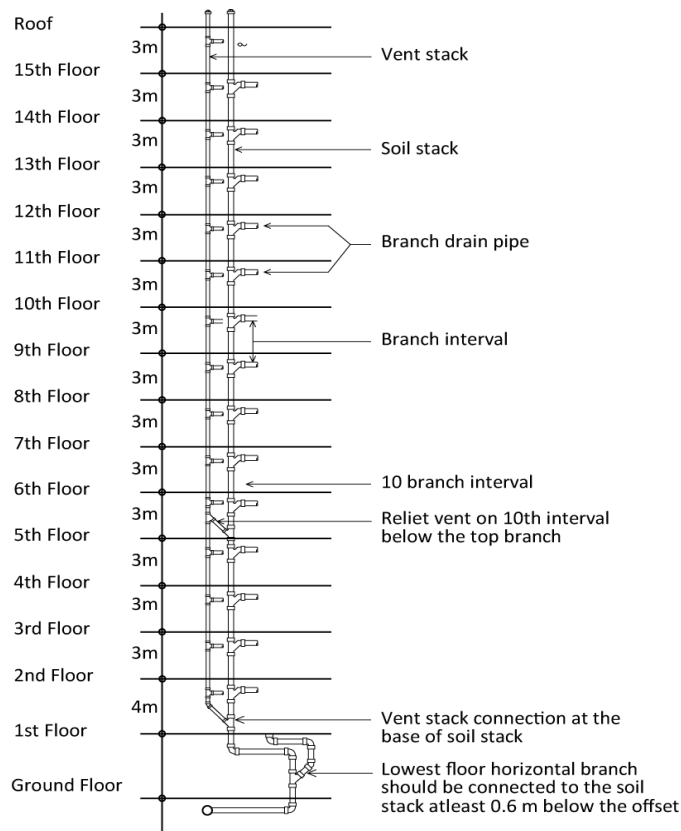


Figure 8.6.7 Relief vents for stack of more than ten branch intervals

Table 8.6.5: Maximum Spacing of Access Points

From	To Access Fitting (m)	To Junction (m)	To Inspection Chamber (m)	To Manhole (m)
Start of external drain	12	-	22	45
Rodding eye	22	22	45	45
Access fitting †	-	12	22	22
Inspection chamber	22	22	45	45
Manhole	22	-	45	90

† higher spacing may be used for larger size access fitting.

Table 8.6.6 Minimum Dimensions for Access Points

Access Points	Depth (m)	Internal Sizes		Cover Sizes	
		Length x width (mm x mm)	Diameter (mm)	Length x width (mm x mm)	Circular (mm)
Rodding eye		min. 100 mm or size of drains			
Access fitting	0.6 or less	150 x 100	150	150 x 100	150
Inspection chamber	1.0 or less	450 x 450	450*	450 x 450	450*
Manhole	1.5 or less	1200 x 750	1050	600 x 600	600
	over 1.5	1200 x 750	1200	600 x 600	600
	over 2.7	1200 x 840	1200	600 x 600	600

* 190 mm dia may be used for depth ≤ 0.6 m

6.9.7.3 Access should be one of the following four types :

- (i) Rodding eyes - capped extensions of the pipes,
- (ii) Access fittings - small chambers (or an extension of the pipes) but not with an open channel,
- (iii) Inspection chambers - chambers with working space at ground level, and
- (iv) Manholes - large chambers with working space at drain level.

6.9.7.4 Inspection chambers and manholes shall have removable non-ventilating covers of durable material and be of suitable strength. Inspection chambers and manholes in buildings shall have mechanically fixed airtight covers unless the drain itself has watertight access covers. Manholes deeper than 1 m shall have non-corrosive steps or fixed ladders. Figures 8.6.8 and 8.6.9 show the details of typical manholes at smaller depth (<1 m) and at higher depth (>1 m) respectively. Figure 8.6.9 shows the details of a drop manhole. The drop manhole is a manhole that serves as a junction and receives sewer lines at two different elevations.

6.9.7.5 Spacing of manholes

The spacing of manholes for a given pipe size should be as follows :

Pipe Diameter (mm)	Spacing of Manhole (m)
Up to 300	45
301 to 500	75
501 to 900	90

Beyond 900 Spacing shall depend upon local condition and shall be gotten approved by the Authority

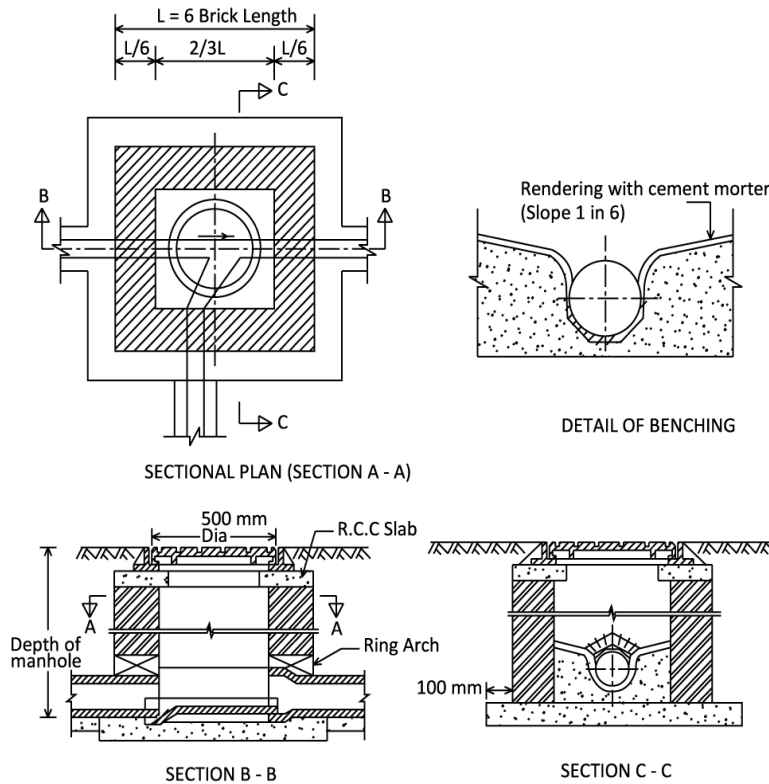


Figure 8.6.8 Detail of Manhole (Depth 1m and Below)

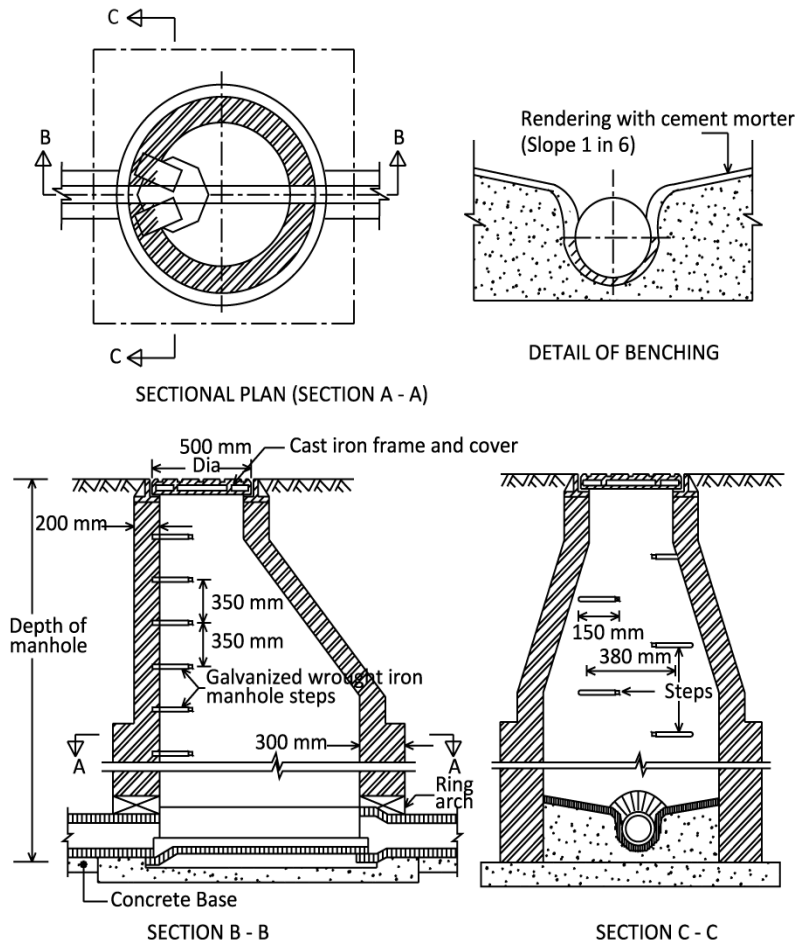


Figure 8.6.9 Detail of manhole (depth more than 1 m)

6.9.8 Protection Against Rodent

Holes through walls shall be such that they will not provide passage of rodent or other insects from room to room or from floor to floor. Materials used for embedding pipes shall be rodent proof.

6.9.9 Bedding and Backfilling

The choice of bedding and backfilling depends on the depth of the bed, and size and strength of the materials. Table 8.6.7 and Figure 8.6.10 show two types of bedding and backfilling, and minimum and maximum depth of cover for each type of bedding for rigid pipings. The bedding and backfilling for flexible pipings is shown in Figure 8.6.11. The minimum depth of bedding for flexible pipings shall be 0.3 m where there will be no extra surcharge load coming on pipe other than back filling.

The depth shall not be more than 10 m. The flexible pipe may be laid with less cover in fields and gardens. The bedding and backfilling shall be in accordance with Figure 8.6.12.

Table 8.6.7: Limits of Cover (m) for Standard Strength Rigid Pipes in any Width of Trench

Pipe Bore (mm)	Bedding Class	Fields and Gardens		Light Traffic Roads		Heavy Traffic Road	
		Min	Max	Min	Max	Min	Max
100	Type 1	0.3	7.4	0.4	7.4	0.4	7.2
	Type 2	0.3	5.8	0.5	5.8	0.5	5.5
150	Type 1	0.6	5.0	0.6	5.0	0.6	4.6
	Type 2	0.6	3.9	0.7	3.8	0.7	3.3

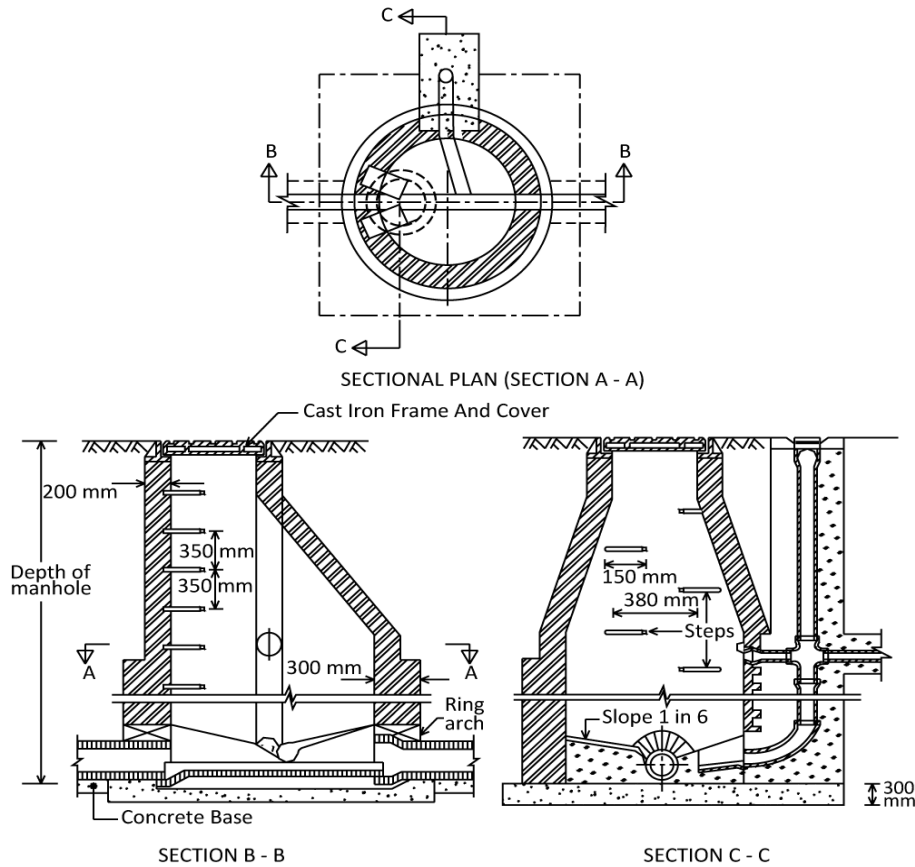


Figure 8.6.10 Drop manhole

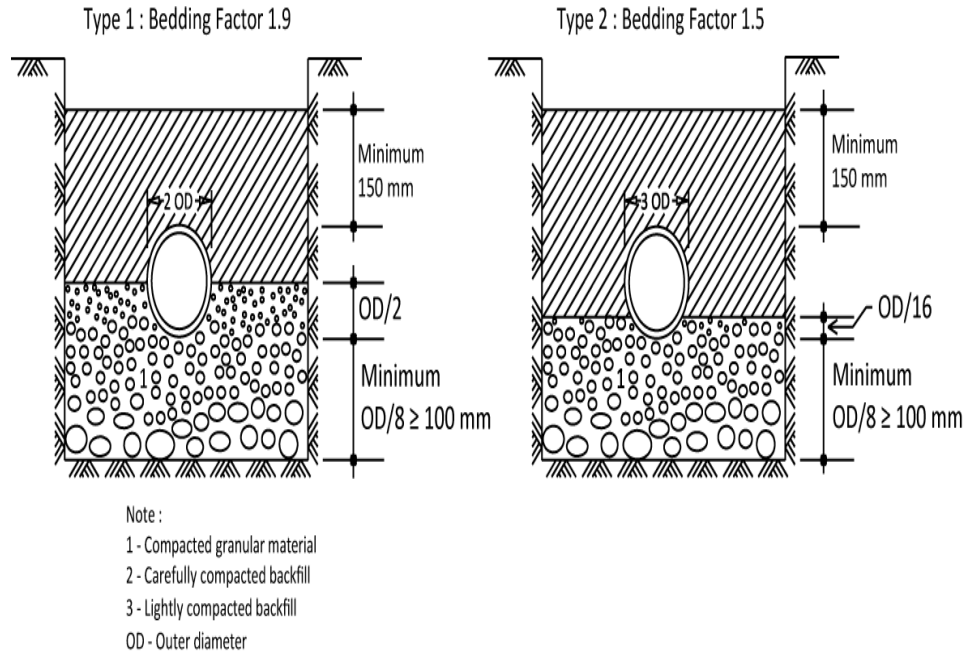


Figure 8.6.11 Bedding for rigid pipes

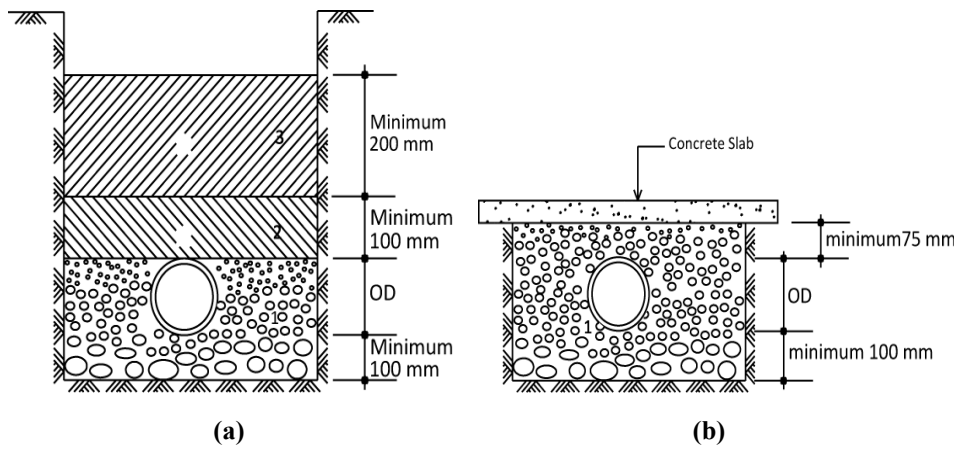


Figure 8.6.12 (a) Bedding for flexible pipes; (b) Flexible pipes bedding under concrete slab

6.9.10 Grease Traps

Oil and grease is found in wastes generated from kitchens in hotels, industrial canteens, restaurant, butcheries, some laboratories and manufacturing units having a high content of oil and greases in their final waste.

Waste exceeding temperature of 60° C should not be allowed in the grease trap. When so encountered it may be allowed to cool in a holding chamber before entering the grease trap.

Oil and greases tend to solidify as they cool within the drainage system. The solidified matter clogs the drain and the other matter in the waste stick to it due to the adhesion properties of the grease. Oil and greases are lighter than water and tend to float on the top of the waste water.

Grease traps shall be installed in building having the above types of wastes. In principle the grease laden water is allowed to retain in a grease trap which enables any solids to be settled or separated for manual disposal. The retention time allows the incoming waste to cool and allow the grease to solidify. The clear waste is then allowed to discharge into the building's drainage system.

6.9.11 Oil Interceptors

Oils and lubricants are found in wastes from vehicle service stations, workshops manufacturing units whose waste may contain high content of oils. Oils, for example, petroleum, kerosene and diesel used as fuel, cooking, lubricant oils and similar liquids are lighter than water and thus float on water in a pipe line or in a chamber when stored. Such oils have a low ignition point and are prone to catch fire if exposed to any flame or a spark and may cause explosion inside or outside the drainage system. The flames from such a fire spread rapidly if not confined or fire vented at the possible source. Lighter oils and lubricants are removed from the system by passing them through an oil interceptor/petrol gully. They are chambers in various compartments which allow the solids to settle and allow the oils to float to the top. The oil is then decanted in separate containers for disposal in an approved manner. The oil free waste collected from the bottom of the chamber is disposed in the building drainage system.

6.9.12 Septic Tank

6.9.12.1 Septic tank (Figures 8.6.13 and 8.6.14) discharging into either a subsurface disposal field or one or more seepage pits shall be required for the approval of drainage and sanitation plans for the places where public sewers are not available.

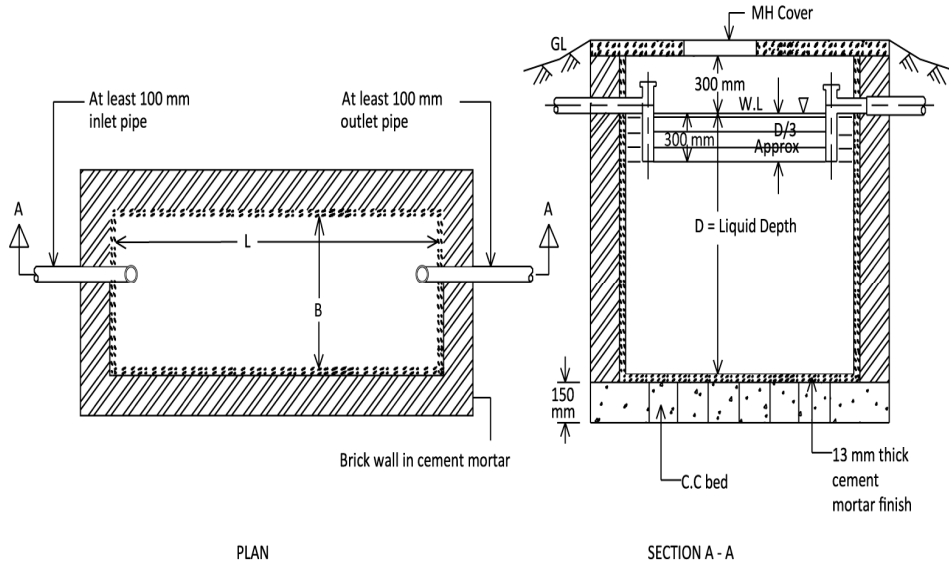


Figure 8.6.13 Typical one chamber brick septic tank

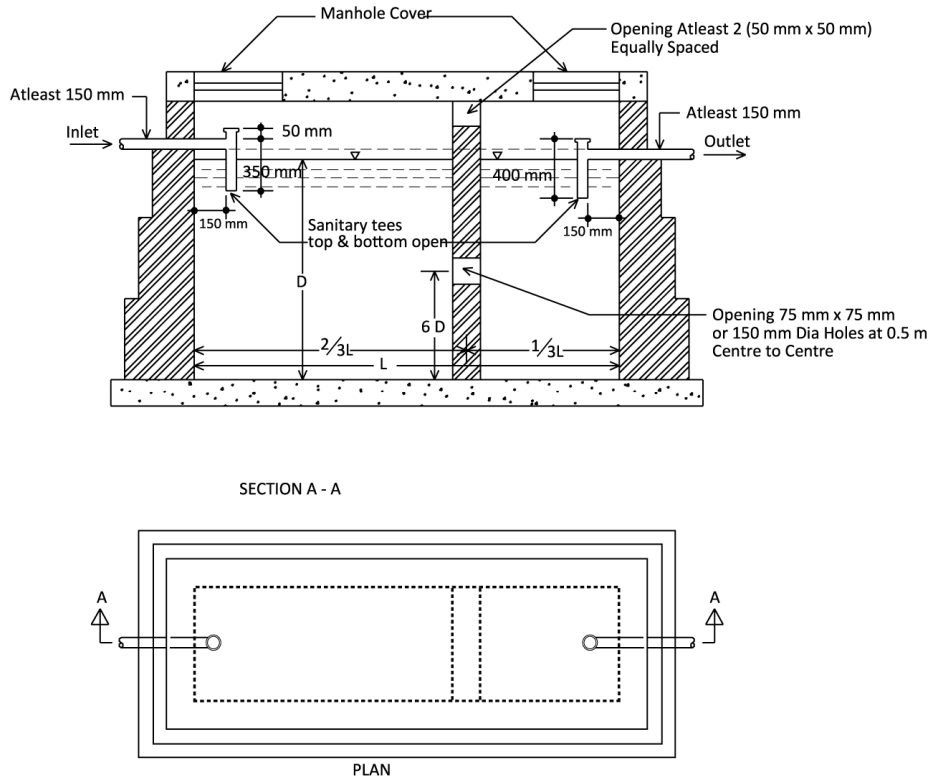


Figure 8.6.14 Typical two chamber concrete septic tank

6.9.12.2 Such disposal method shall be designed by a licensed professional in accordance with the requirement of the provisions of this Code and regulations of the concerned authorities.

6.9.12.3 The design of such system shall be on the basis of location with respect to wells or other sources of water, soil permeability, ground water elevation, area available and maximum occupancy of the building.

6.9.12.4 Sullage water shall not be discharged into the septic tank.

6.9.12.5 Effluent from septic tank(s) shall not discharge into open water courses.

6.9.12.6 The minimum distance for various components of the disposal system shall be in accordance with Table 8.6.8.

6.9.12.7 The flow into a septic tank may be calculated on the basis of plumbing fixtures discharging soil wastes simultaneously into it. The capacity of septic tank for residential buildings shall be determined according to the formula in Appendix S. For other occupancies a reduction factor shall be used as shown in Appendix S.

6.9.12.8 The septic tank shall have a minimum liquid capacity of 2000 liters, minimum width 1 m and minimum liquid depth 1 m. The minimum length of a septic tank shall be at least thrice its width. It is recommended that the maximum length of a septic tank shall be not more than 4 times its width.

6.9.12.9 The maximum size of a septic tank shall be limited to the number of users not exceeding 300 persons for residential buildings.

6.9.12.10 The volume required for digested sludge and scum may be computed on the basis of 0.04 m³/capita/ year. There shall be a clearance between top of the liquid level and bottom of the tank cover slab which shall be at least 300 mm.

6.9.12.11 The liquid retention time of a septic tank shall be at least 1 day.

6.9.12.12 The desludging frequency of a septic tank shall be at least 6 months interval and maximum once a year.

6.9.12.13 It is recommended to use a two chamber septic tank when the capacity of a septic tank exceeds 3000 liters. The inlet compartment of a two chamber septic tank shall have a capacity not less than two-third of its total capacity (Figure 8.6.14).

Table 8.6.8: Location of Components of Sewage Disposal System

System Component	Distance (m)				
	Building Foundation	Well	Stream	Seepage Pit	Dry Well
Septic tank	1.5	8	-	1.5	-
Disposal field	3	15	7.5	6	6
Seepage pit	4.5	15	15	6	6
Dry well	3	15	-	6	-

6.9.12.14 The septic tank shall be constructed of corrosion resistant material and be of permanent water tight construction. The manhole cover and the roof of the tank shall be designed for at least 7 kPa live load. The inlet compartment shall be provided with a manhole. Outlet compartment shall also be provided with a manhole. The design guideline of a septic tank is presented in Appendix S.

6.9.13 Imhoff tank(s)

6.9.13.1 Imhoff tank (Figure 8.6.15) discharging into either a subsurface disposal field or one or more seepage pits shall be required for the approval of drainage and sanitation plans for the places where public sewers are not available.

6.9.13.2 Imhoff tank shall be used where more than 300 peoples of residential buildings are to be served.

6.9.13.3 The settling chamber shall be designed for a detention period of 1.5 to 4.0 hours and an over flow rate of 0.95 to 1.4 m/hr. The displacement velocity should not be more than 18 m/hr. Sloping sides of settling chamber shall have inclination 1.0 horizontal to 1.2 vertical. The slot at the bottom is 0.15 to 0.25 meter measured along the slope of the hopper. The width of the side spaces should not be less than 0.45 meter. The digestion chamber should have a capacity to store about 6 to 12 months digested sludge. Capacity of the digestion chamber can be found from the following formula-

$$C = \left[V_f - \frac{2}{3}(V_f - V_d) \right] t \quad (8.6.1)$$

Where, C is the volume of the digestion tank in m^3/capita below the neutral zone which is 0.2 m below the slot. V_f is the volume of fresh sludge in $m^3/\text{capita}/\text{day}$ and V_d is the volume of the digested sludge in $m^3/\text{capita}/\text{day}$ and t is the time required for digestion. The digestion chamber should have sloping side with a ratio of 4 horizontal to 5 vertical.

6.9.13.4 The Capacity found in Sec. 6.9.12.3 is true for residential buildings. For other occupational buildings use a reduction factor as shown in Appendix S.

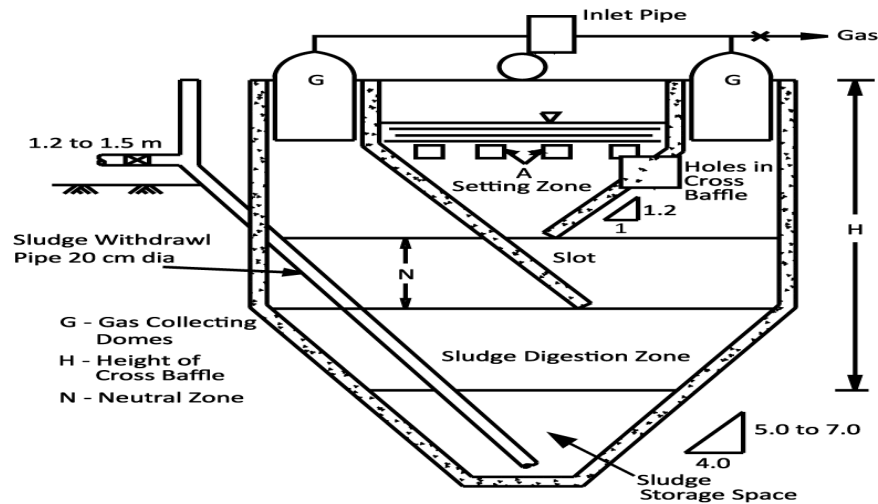


Figure 8.6.15 Cross section of an imhoff tank

6.9.14 Installation

Septic and Imhoff tanks shall be located with a horizontal distance not less than specified in Table 8.6.9 between various elements. Tanks installed in ground water shall be securely anchored. Three inch (75 mm) thick compacted bedding shall be provided for all septic and other treatment tank installations. The bedding material shall be sand, gravel, granite, lime rock or other noncorrosive materials of such size that the material passes through a 0.5 inch (12.5 mm) screen.

Table 8.6.9: Minimum horizontal separation distances for treatment tanks element distance

Elements	Distance (m)	Elements	Distance (m)
Building	1.5	Reservoir	7.5
Cistern	7.5	Spring	15
Foundation wall	1.5	Stream or watercourse	7.5
Lake, high water mark	7.5	Swimming pool	4.5
Lot line	0.6	Water service	1.5
Pond	7.5	Well	7.5

Each cleanout shall be installed so that it opens to allow cleaning in the direction of flow of the soil or waste or at right angles thereto, and except in the case of Wye branch and end-of-line cleanouts, shall be installed vertically above the flow line of the pipe.

The bath tub shall be fitted with overflow and waste pipe of nominal diameter of not less than 32 mm and 40 mm respectively.

6.9.15 Disposal Field and Seepage Pit

6.9.15.1 A distribution box shall be provided to receive the effluent from the septic tank or Imhoff tank to assure equal distribution to each individual line of disposal field. The distribution box shall be connected to the septic tank or Imhoff tank by a watertight sewer line and shall be located at the upper end of disposal field. Figure 8.6.16 shows the plans and sections of typical distribution boxes.

6.9.15.2 Soil percolation tests (at least for three holes) shall be performed at the site of a proposed individual sewage disposal system installation to determine the suitability of soil and site.

6.9.15.3 The liquid capacity (volume below inlet line) of seepage units (disposal field or seepage pit) shall be at least twice that of a septic tank or Imhoff tank. Effective absorption area of seepage unit may be computed in accordance with Table 8.6.10.

6.9.15.4 No seepage unit shall be extended into water table directly. The bottom of seepage unit shall be at least 1 meter above the highest water table.

6.9.15.5 Each disposal field shall have at least two outlet distribution lines from the distribution box. No portion of disposal field shall be installed under any pavement or any area where there will be vehicular traffic or parking

6.9.15.6 Minimum standards for disposal field construction shall be as shown in Table 8.6.11.

6.9.15.7 Seepage pit (soak pit) shall be lined with stone, brick or concrete blocks laid up dry with open joints that are backed up with at least 75 mm coarse aggregate. The joints above the inlet shall be sealed with cement mortar. A reinforced concrete cover shall be provided. For cover area more than 0.75 m² the pit shall have an access manhole. The bottom of the pit shall be filled with coarse gravel, or crushed stone/brick to a depth of 300 mm. Figure 8.6.17 provides the details of a seepage pit.

6.9.15.8 Large dry well shall be constructed in accordance with the requirements for seepage pit (Sec 6.9.12). However, for small dry wells handling limited quantities of waste water the pit may consist of a 2.0 m deep and 1.0 m diameter pipe filled with crushed bricks/stone, Figures 8.6.18 and 8.6.19.

6.9.15.9 French drains may be employed as surface water drains for drainage of unpaved surfaces.

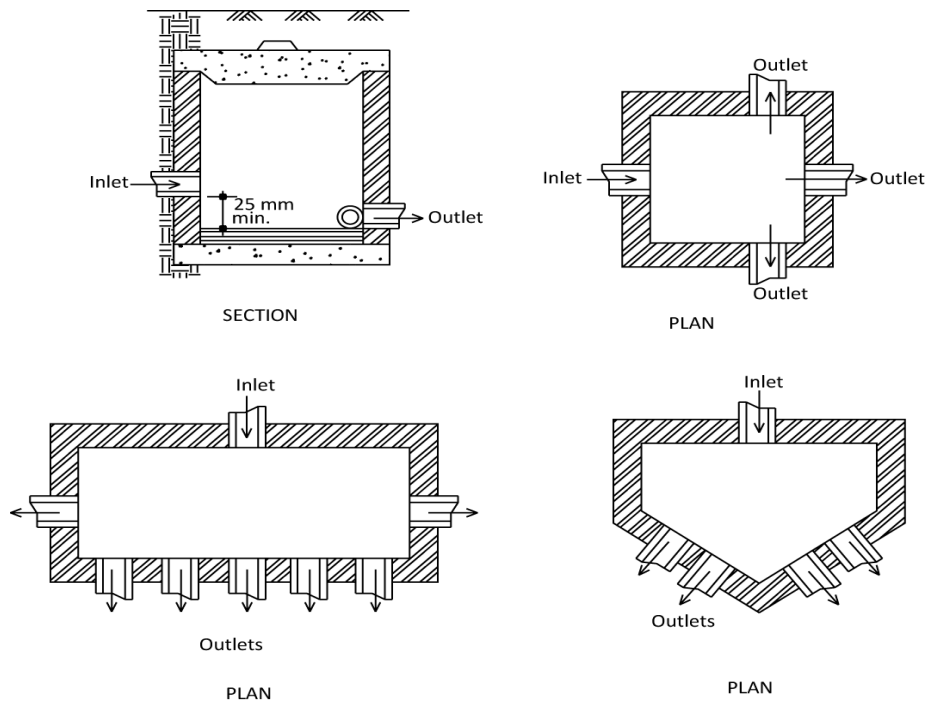


Figure 8.6.16 Distribution boxes

Table 8.6.10: Absorptive Capacity of Disposal Field and Seepage Pit

Percolation Test Rate in Minutes for Water to Fall 25 mm	Effluent Allowance Rate of Seepage Unit (l/m ² /day)	
	Disposal Field Trenches (bottom of trench)	Seepage Pit (wall area)
2 or less	128	172
5	96	128
10	68	92
30	32	44
60 (not recommended)	16	24
over 60 (not suitable)	-	-

Table 8.6.11: Design Features of Disposal Field

Design Items	Requirements
Number of lateral branches	2
Maximum length of branch	20 m
Minimum diameter of field distribution pipe	100 mm
Maximum slope of field distribution pipe	3.3 mm per m
Depth of trench	0.45 m to 9 m
Trench bottom, minimum above ground water	0.61 m
Trench bottom width	0.45m to 0.75m
Depth of coarse material	
under pipe	150 mm
over pipe	50 mm
Size of coarse material	12 mm to 63 mm

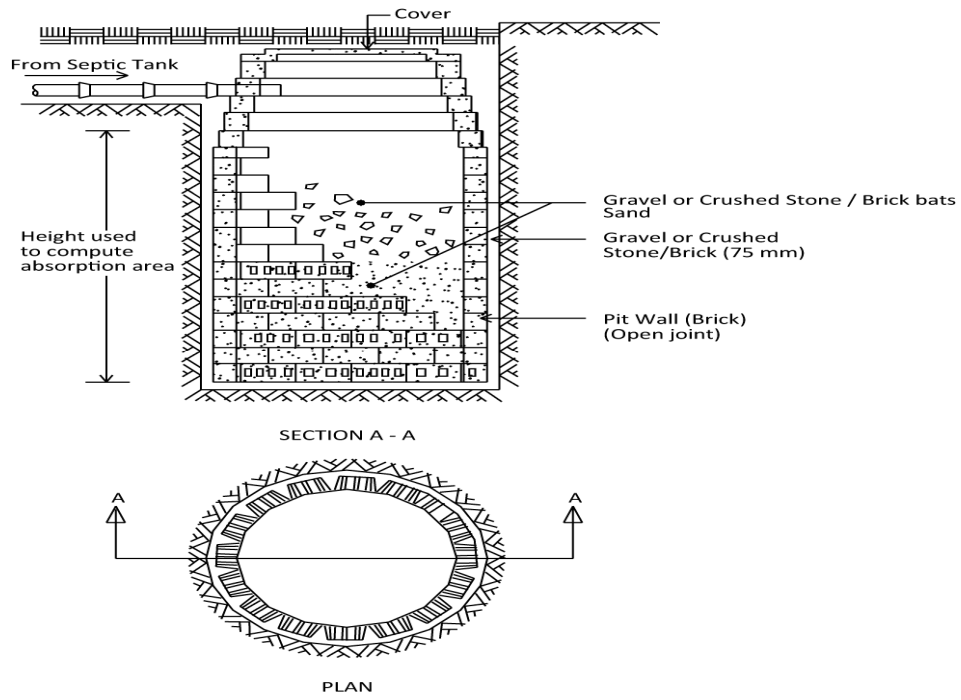


Figure 8.6.17 Typical seepage pit

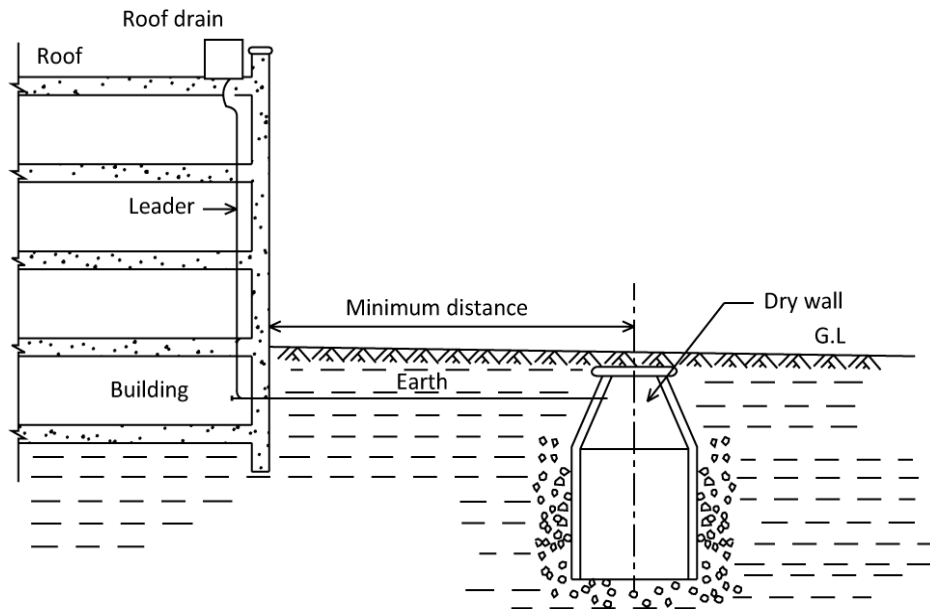


Figure 8.6.18 Typical location of a dry wall

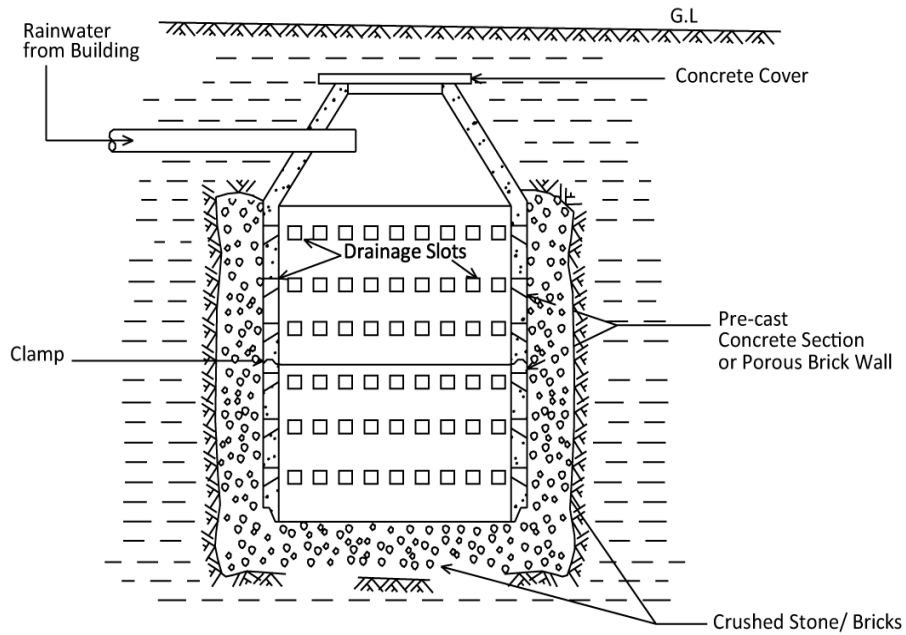


Figure 8.6.19 Installation details of a dry wall

6.10 Design of Drainage and Sanitation System

6.10.1 Estimation of Maximum Load Weight of Waste Water

To estimate the total load weight carried by a soil or waste pipe, the relative load weight for different kinds of fixtures are provided in Table 8.6.12. Table 8.6.13 provides an approximate rating of those fixtures not listed in Table 8.6.12.

Table 8.6.12: Fixture Units for Different Sanitary Appliances or Groups

Type of Fixture	Fixture Unit Value as Load Factor
One bathroom group consisting of water closet, wash basin and bath tub or shower stall :	
a) Flush Tank water closet	3
b) Flush-valve water closet	6
Bathtub*	2
Bidet	2

Type of Fixture	Fixture Unit Value as Load Factor
Combination sink and tray (drain board)	2
Drinking fountain	0.5
Floor traps†	1
Kitchen sink, domestic	2
Wash basin, ordinary‡	1
Wash basin, surgeon's	2
Shower stall, domestic	2
Shower (group) per head	3
Urinal, wall hung	4
Urinal, stall	4
Water closet, tank operated	3
Water closet, valve operated	6

* A shower head over a bath tub does not increase the fixture unit value.
† Size of floor trap shall be determined by the area of surface water to be drained.
‡ Wash basin with 32 mm and 40 mm trap have the same load value.

Table 8.6.13: Fixture Unit Values for Fixtures Based on Fixture Drain or Trap Size

Fixture Drain on Trap Size	Fixture Unit Value
30 mm and smaller	1
40 mm	2
50 mm	3
65 mm	4
75 mm	5
100 mm	6

6.10.2 Gradient and Size of Pipe

6.10.2.1 The building drains and sewer shall be designed to discharge the peak simultaneous load weight flowing half-full with a minimum self-cleansing velocity of 0.75 m per second. However, flatter gradient may be used if required but the minimum velocity shall not be less than 0.6 m per second. Again, it is undesirable to employ gradients giving a velocity of flow greater than 2.5 m per second.

6.10.2.2 The maximum number of fixture units that may be connected to a given size of building sewer, building drain, horizontal branch or vertical soil or waste stack is provided as in Tables 8.6.14 and 8.6.15.

6.10.3 Size of Vent Piping

6.10.3.1 The size of vent piping shall be determined from its length and the total number of fixture units connected thereto in accordance with Table 8.6.16.

6.10.3.2 The branch vent shall be sized in accordance with Table 8.6.17.

Table 8.6.14: Maximum Number of Fixture Units that can be connected to Branches and Stacks

Diameter of Pipe (mm)	Any Horizontal Fixture Branch ^a	One Stack of 3 Storeys in Height or 3 Intervals	More than 3 Storeys in Height	
			Total for Stack	Total at One Storey or Branch Interval
30	1	2	2	1
40	3	4	8	2
50	6	10	24	6
65	12	20	42	9
75	20	30	60	16
100	160	240	500	90
125	360	540	1100	200
150	620	960	1900	350
200	1400	2200	3600	600
250	2500	3800	5600	1000
300	3900	6000	8400	1500
375	7000	b	b	b

^a Does not include branches of the building sewer. ^b Sizing load based on design criteria

Table 8.6.15: Maximum Number of Fixture Units that can be connected to Building Drains and Sewers

Diameter of Pipe (mm)	Maximum Number of Fixture Units that can be Connected to any Portion* of the Building Drain or the Building Sewer for Various Slopes			
	1/200	1/100	1/50	1/25
100	-	180	216	250
150	-	700	840	1000
200	1400	1600	1920	2300
250	2500	2900	3500	4200
300	2900	4600	5600	6700
375	7000	8300	10000	12000

* Includes branches of building sewer

6.11 Construction Relating to Conveyance of Sanitary Wastes

6.11.1 Conveyance of Sanitary Wastes

6.11.2 The layout of drainage systems shall be simple. Change of direction and gradient shall be minimized and shall be as easy as practicable.

6.11.3 The excavation, where necessary, shall be made in accordance with Table 8.6.18.

6.11.4 The depth of cover shall be in accordance with Sec 6.9.9.

6.11.5 The pipe shall be laid to even gradients and change of gradient shall be combined with an access point (Sec 6.10.2). However, access points shall be provided only if blockages could not be cleared without them.

6.11.6 The joints and connection in drainage and venting system shall be gastight and watertight for the pressures required by the test, with the exception of those portions of perforated or open joint piping which will be installed for the purpose of collecting and conveying ground or seepage water to the underground storm drains.

6.11.7 Piping in drainage and venting system shall be installed without undue strains and stresses and provision shall be made for expansion, contraction and structural settlement. Vertical piping shall be secured at sufficiently close intervals to keep the pipe in alignment and carry the weight of the piping and its content. The horizontal piping shall be supported at sufficiently close intervals to keep it in alignment and to prevent sagging.

Table 8.6.16: Size and Length of Vent Stacks and Stack Vents

Diameter of Soil or Waste Stack (mm)	Total Fixture Unit Connected to fixture	Maximum Development Length of Vent (m)* for Diameter (mm) of Vent Pipes										
		30	40	50	65	75	100	125	150	200	250	300
30	2	9										
40	8	15	45.5									
40	10	9	30.5									
50	12	9	22.5	61								
50	20	8	15	45.5								
65	42		9	30.5	91.5							
75	10		12.5	45.5	109.5	317						
75	21		9.5	33.5	82	247						
75	53		8	28.5	70	207						
75	102		7.5	26	64	189						
100	43			10.5	26	76	298.5					
100	140			8	19.5	61	228.5					
100	320			7	16.5	52	195					
100	540			6.5	15	45.5	176.5					
125	190				8.5	25	97.5	301.5				
125	490				6.5	19	76	231.5				
125	940				5.5	16	64	204				
125	1400				4.5	15	58	180				
150	500					10	39.5	122	305			

Diameter of Soil or Waste Stack (mm)	Total Fixture Unit Connected to fixture	Maximum Development Length of Vent (m)* for Diameter (mm) of Vent Pipes										
		30	40	50	65	75	100	125	150	200	250	300
		150	1100					6.5	30.5	94.5	237.5	
150	2000					6	25.5	79	201			
150	2900						23.5	73	183			
200	1800						9.5	29	73	286.5		
200	3400						7	22	58	219.5		
200	5600						6	19	48.5	186		
200	7600						5.5	17	42.5	170.5		
250	4000							9.5	23.5	94.5	292.5	
250	7200							7	18	73	225.5	
250	11000							6	15.5	61	192	
250	15000							5.5	14	55	173.5	
300	7300								9.5	36.5	116	286.5
300	13000								7	28.5	91.5	219.5
300	20000								6	24	76	186
300	26000								5.5	22	70	152.5
375	15000									12	39.5	94.5
375	25000									9.5	29	73
375	38000									8	24.5	61
375	50000									7	22.5	55

* The development length shall be measured from the vent connection to the open air

Table 8.6.17: Minimum Diameter and Maximum Length of Individual, Branch, and Circuit Vents for Horizontal Drainage Branches

Diameter of Horizontal Drainage Branch (mm)	Slope of Horizontal Drainage Branch (mm/m)	Maximum Development Length of Vent (m) for Diameter (mm) of Vent Pipe									
		30	40	50	65	75	100	125	150	200	250
30	20	NL*									
	40	NL									
40	20	NL	NL								
	40	NL	NL								
50	10	NL	NL	NL							
	20	88	NL	NL							
	40	45	115	NL							
65	10	54	137	NL							
	20	29	73	NL	NL						
	40	15	39	NL	NL						
75	10	-	58	NL	NL	NL					
	20	29.5	128	NL	NL						
	40	15	67	NL	NL						
100	10	-	58	NL	NL	NL					
	20		30	94	NL	NL					
	40		14.5	48.5	125	NL					
125	10				149	NL	NL				
	20				58	76	NL	NL			
	40				29.5	39.5	NL	NL			
150	10					NL	NL	NL			
	20				14	58	76	NL	NL		
	40					29.5	39.5	NL	NL		
200	10						NL	NL	NL		
	20					14	58	94.5	NL	NL	
	40						27.5	45.5	125	NL	NL

Diameter of Horizontal Drainage Branch (mm)	Slope of Horizontal Drainage Branch (mm/m)	Maximum Development Length of Vent (m) for Diameter (mm) of Vent Pipe									
		30	40	50	65	75	100	125	150	200	250
250	10								152	NL	NL
	20					11.5	58	73	NL	NL	
	40						26	33.5	NL	NL	
300	10						9.5	54.5	NL	NL	
	20							24	128	NL	
	40							8	61	NL	

* NL means no limit; Actual value in excess of 150 m.

Table 8.6.18: Minimum Width at Bottom of Trench

Depth of Trench (m)	Width of Trench (m)
Up to 1.2	Diameter of pipe plus 0.4
Above 1.2	Diameter of pipe plus 0.45

Note: Trench top width shall not be less than 0.75 m for depths exceeding 0.9 m

6.12 Refuse Chute System

6.12.1 All buildings higher than 6-storeys shall be provided with refuse chute system for transporting and collecting refuse from different floors in a sanitary way. The refuse shall be received from the respective floor through an inlet hopper in to the chute which conveys refuse and discharges into the collection chamber. The refuse from the collection chamber shall be cleared at suitable intervals.

6.12.2 The refuse chute, inlet hopper and collection chamber shall be constructed with smooth and nonflammable materials.

6.12.3 The hopper shall be self-cleaning and shall be fitted with self-closing shutter to prevent the passage of foul gases inside the building.

6.12.4 The diameter of the chute shall not be less than 300 mm. It shall be adequately ventilated at the top. The chute shall be provided with suitable arrangements for flushing with water for the full length.

6.13 Basement Floor Drainage System

6.13.1 All buildings having basement floor below the surrounding sewer system and area more than 1000 m² shall have pumping system to drain out wastewater.

6.13.2 All buildings having basement floor below the surrounding sewer system and area more than 1000 m² shall have one sump pit for every 1000 m².

6.13.3 For more than one sump pit, pits shall be connected to a master sump pit from where pumping shall be done to drain out the waste. Minimum diameter of sump pit connection drain pipe shall be 75 mm.

6.13.4 For wastewater and sewage drainage from basement floor separate drainage system shall be provided.

6.13.5 The collection chamber shall be of suitable size and located at ground level.

6.13.6 The design and arrangement of the system shall be in accordance with established engineering practices.

6.14 Health Care Drainage System

6.14.1 General

The health care drainage system shall comply with applicable drainage and venting requirements specified in this Chapter and with this Section.

6.14.2 Special Fixtures and Equipment

The hospital shall be provided with clinical sink, bedpan washer and such other fixtures and equipment for disposal of bedpan contents and for the cleansing and disinfection of such fixtures. A clinical sink shall not be considered as a substitute for service sink.

6.14.3 Bedpan Washer and Clinical Sink

Bedpan washer and clinical sink shall be connected to soil branches and soil stacks through a water seal trap. The bedpan washer with vapour vent connection shall be provided with additional local vent stack. The minimum vent stack size for bedpan washer shall be in accordance with Table 8.6.19.

Table 8.6.19: Minimum Vent Stack Size in Bedpan Drainage

No of Bedpan Washer	Diameter (mm)
Up to 3 bedpan washers at different floors	50
4 to 6 bedpan washers	75
7 to 12 bedpan washers	100

The bottom of the bedpan local vent stack (except for one bedpan washer) shall be drained indirectly into sanitary drainage system through traps. The size of the trap and connecting pipe shall be at least the size of the vent stack. At least 6 mm diameter water supply piping shall be taken from each flush supply of each bedpan washer on the discharge side of vacuum breaker, trapped to form 75 mm or more trap seal and connected to the local vent stack on each floor.

6.14.4 Sterilizer Vent Stack

The pressure or non-pressure sterilizer shall have vent connection to the sterilizer vent stack. This vent connection shall be accessible for inspection and cleaning. The size of sterilizer vent stack shall be as follows:

6.14.4.1 Pressure sterilizers

The minimum diameter for pressure sterilizer vent stack shall be 63 mm. The stack size for combinations of pressure sterilizer exhaust shall be in accordance with Table 8.6.20.

Table 8.6.20: Pressure Sterilizer Vent Stack Size

Stack Size (mm)	Number of Connections Permitted for Different Combination Sizes (mm)			
	19	25	31	38
38	3	-	-	-
	-	2	-	-
	-	-	1	-
	2	1	-	-
50	6	-	-	-
	-	3	-	-
	-	-	2	-
	-	-	-	1
	3	2	-	-
	2	1	1	-
75	1	1	-	1
	15	-	-	-
	-	7	-	-
	-	-	5	-
	-	-	-	3
	1	5	-	1
-	1	2	2	

6.14.4.2 Pressure instrument washer sterilizers

The minimum size of sterilizer vent stack for instrument washer sterilizer shall be 50 mm for up to two sterilizers. The 75 mm stack will serve up to four sterilizers.

6.14.4.3 Non-pressure sterilizers

The minimum diameter of non-pressure sterilizer vent stack shall be 50 mm for utensil sterilizer and 38 mm for instrument sterilizer. Multiple installations shall be sized in accordance with Table 8.6.21.

6.14.4.4 Bedpan steamers

The diameter for one bedpan steamer shall be 38 mm. The stack size for combinations shall be in accordance with Table 8.6.21.

6.14.5 Vent Extension

The termination of vent stack shall be in accordance with Sections 6.9.5.6 and 6.9.6.7.

Table 8.6.21: Non-pressure Sterilizer Vent Stack or Bedpan Steamer Sizes

Stack Sizes (mm)	No of Connections Permitted for Different Connection Sizes(mm)	
	38	50
38	1	-
50	2	-
	-	1
75	1	1
	4	-
	-	2
100	2	2
	8	-
	-	4
	4	4

6.14.6 Special Fixture Drainage

The device, appurtenance and appliance required for special purposes such as refrigerators, ice boxes, cooling or refrigerating coils etc. shall be protected against backflow with adequate air gap between the equipment inlet and drainage outlet.

6.14.7 Mental Health Care Centre and Prisoners Cell

The pipes and traps used in mental health care buildings and prisoner cells shall not be exposed and all fixtures shall be securely bolted through walls.

6.15 Inspection, Testing and Completion Certificate

6.15.1 Inspection

The new drainage and sanitation system or part of the existing system shall not be covered or enclosed or put into operation until it has been inspected, tested and approved by the Authority. The Authority may examine the appliances and fittings before their installation or during the progress of the work. An installation of plumbing work, whether new or existing, which is found to be defective or unsafe shall not be allowed to continue in use unless corrections have been made to comply with the Code requirements.

6.15.2 Testing**6.15.2.1 Drainage and venting system**

The piping of drainage and venting system shall be tested first with water. The final test of completed drainage and venting system may be done by smoke test. The water and smoke tests shall be performed as described below:

- (a) **Water Test:** The water test shall be applied to the drainage and venting system either for the whole system or part (section) thereof. For the entire system, all openings in the piping except the highest opening shall be closed, and the system filled with water to the point of overflow. For the system to be tested in sections each opening shall be tightly plugged except the highest opening of the section under test and each section shall be filled with water but no section shall be tested with less than a 3 m head of water. In testing successive sections, at least the upper 3 m of the next preceding section shall be tested so that no joint or pipe in the building (except the top most 3 m of the system) shall have been submitted to a test of less than a 3 m head of water. The water shall be kept in the system or in the portion under test for at least 15 minutes before the inspection starts. The system or the part of the system under test shall be watertight at all points.
- (b) **Smoke Test:** The final test for gas and water tightness of the completed drainage and venting system may be performed by smoke test. The test is performed by filling all traps with water and then introducing smoke into the system produced by one or more smoke machines. When the smoke appears at the stack openings on the roof, they shall be closed and a pressure equivalent to 25 mm head of water shall be built and maintained for 15 minutes before inspection starts.

6.15.2.2 Building sewer

The Connection between building sewer and public sewer or individual sewage disposal system shall be closed by inserting a test plug. The building sewer shall be filled with water under a pressure of not less than 30 kPa for at least 15 minutes. The system shall be able to maintain the test pressure.

6.15.3 Completion Certificate

After the installation of drainage and sanitation system, the licensed plumber shall give a completion certificate to the authority in a prescribed form (Appendix T) for inspection and testing. After testing, the Authority will give the final approval (as presented in completion certificate form, in the Appendix T) to use the system.

6.16 Guide to Maintenance

6.16.1 The drainage and sanitation system shall be maintained in a sanitary and safe operating condition by the owner or his designated agent. All device or safeguards required by the Code shall be maintained in working order.

6.16.2 The following operations shall be carried out during periodical cleaning of a drainage and sanitation system:

- (a) The covers of inspection chambers and manholes shall be removed and the side benching and channels shall be scrubbed.
- (b) All lengths of main and branch drains shall be rodded by means of drain rods and a suitable rubber or leather plunger. After rodding, the drains shall be thoroughly flushed with clean water.
- (c) The ladders/rings in deep manholes and the manhole covers shall be painted.
- (d) All surface drains shall be cleaned.
- (e) All subsoil drains shall be examined for obstruction at the open joints.
- (f) Refuse chute system shall be cleaned.

6.17 List of Related Appendices

Appendix Q	Application for Permit to Construct Drainage and Sanitation System
Appendix R	One-hour Rainfall
Appendix S	Design Guideline of a Septic Tank
Appendix T	Completion Certificate (Drainage and Sanitation Works)

PART VIII
Chapter 7
Rainwater Management

7.1 Purpose

The purpose of this Chapter is to set forth provisions for planning, design and installation of rainwater management systems in buildings.

7.2 Scope

7.2.1 This Chapter specifies the general requirements for rain water harvesting for different categories of buildings according to their occupancy classification together with all ancillary works of ground water recharging such as perforated piping, pits and inspection chambers.

7.2.2 This Chapter also covers the design, installation and maintenance of elements for rain water drainage systems around the building and led to public storm sewers or to nearby suitable surface water system.

7.2.3 The storm water drainage on ground is not covered by this Code.

7.3 Terminology

This Section provides an alphabetical list of all terms used and applicable to this Chapter of the Code. In case of any conflict or contradiction between a definition given in this Section and that in any other chapter or part of the Code, the meaning specified in this Chapter shall govern for interpretation of the provisions of this Chapter.

BEDDING FACTOR	The ratio of the product of design load and factor of safety to the minimum crushing strength.
BRANCH	Any part of the piping system other than a main or riser.
BUILDING DRAIN	The building (house) drain is that part of the lowest piping or open channel of a drainage system which receives the discharges from soil, waste, and other drainage systems inside the walls of the building and conveys the same to the building (house) sewer, beginning at 0.9 m outside the building wall.
BUILDING SEWER	The building (house) sewer is that part of the horizontal piping of a drainage system which extends from the end of the building drain and which receives the discharge of the building drain and conveys it to a public sewer, private sewer, individual sewage disposal system, or other point of disposal. Also known as SEWER.

BUILDING STORM DRAIN	A building (house) storm drain is a building drain used for conveying rain water, surface water, ground water, subsurface water, condensate, cooling water, or other similar discharge to a building storm sewer or a combined sewer, extending to a part not less than 0.9 m outside the building wall. Also known as STORM DRAIN.
DRAIN	A drain is any pipe or open channel which carries waste water or waterborne wastes in a building drainage system.
DRAINAGE SYSTEM	A drainage system (drainage piping) includes all piping within public/private premises which conveys sewage, rain water, or other liquid wastes to a legal point of disposal, but does not include mains of public sewer system or private or public sewage treatment or disposal plant.
DRINKING FOUNTAIN	A fountain or a tap raised from the floor with potable water supply connection.
EXISTING WORK	The existing work is a plumbing system or any part thereof which was installed prior to the date of enforcement of this Code.
FIXTURE UNIT	A fixture unit is a quantity in terms of which the load producing effects on the plumbing system of different kinds of plumbing fixtures are expressed on some arbitrarily chosen scale.
FLUSH VALVES	A flush valve is a device located at the bottom of the tank for the purpose of flushing water closets and similar fixtures.
FRENCH DRAIN	A shallow trench filled with coarse rubble, clinker or similar material with or without field drain pipes.
GRADE	The grade is the slope or fall of a line of pipe in reference to a horizontal plane. In drainage it is usually expressed as the fall in mm per m length of pipe.
HORIZONTAL BRANCH	A horizontal branch is a drain pipe extending laterally from a soil or waste stack or building drain, with or without vertical sections or branches, which receives the discharge from one or more fixture drains and conducts it to the soil or waste stack or to the building (house) drain.
HORIZONTAL PIPE	A horizontal pipe is any pipe or fitting which is installed in a horizontal position or which makes an angle of less than 45 degrees with the horizontal.

INTERCEPTOR	An interceptor is a device designed and installed so as to separate and retain deleterious, hazardous, or undesirable matter from normal wastes and permit normal or liquid wastes to discharge into the disposal terminal by gravity.
INVERT	The lowest point of the internal surface of a pipe or channel at any cross-section.
LEADER	A vertical drainage pipe that carries rainwater from roof or gutter drain to building storm drain or building drain or private disposal system.
LIQUID WASTE	The liquid waste is the discharge from any fixture, appliance, or appurtenance in connection with a plumbing system which does not receive fecal matter.
LOAD FACTOR	The load factor is the percentage of the total connected fixture unit flow rate which is likely to occur at any point in the drainage system. It varies with the type of occupancy, the total flow unit above the point being considered, and with the probability factor of simultaneous use.
MAIN	The main of any system of continuous piping is the principal artery of the system, to which branches may be connected.
MAIN SEWER	See Public Sewer.
MANHOLE	An opening by which a man may enter or leave a drain, a sewer or other closed structure for inspection, cleaning and other maintenance operations, fitted with a suitable cover.
MANHOLE CHAMBER	A chamber constructed on a drain or sewer so as to provide access thereto for inspection, testing or the clearance of obstruction.
OFFSET	An offset in a line of piping is a combination of elbows or bends which brings one section of the pipe out of line but into a line parallel with the other section.
PUBLIC SEWER	A public sewer is a common sewer directly controlled by public authority. Also known as MAIN SEWER.
RISER	A water supply pipe that extends vertically one full storey or more to convey water to branches or fixtures.
SANITARY SEWER	A sanitary sewer is a pipe which carries sewage and excludes storm, surface, and ground water. Also known as SEWER.
SEEPAGE PIT	See SOAK PIT.

SEWAGE	The sewage is any liquid waste containing animal or vegetable matter in suspension or solution and may include liquids containing chemicals in solution.
SEWER	See BUILDING SEWER or PUBLIC SEWER or SANITARY SEWER or STORM SEWER.
SLUDGE	A settled portion of the sewage or waste water effluent from a sedimentation tank in semi-solid condition.
SOAK PIT	A pit, dug into permeable soil lined to form a covered perforated chamber or filled with sand at the bottom and gravel or broken bricks at the top into which effluent from a septic tank or storm water is led and from which these may soak away into the ground. Also known as SEEPAGE PIT or SOAK WELL.
SOAK WELL	See SOAK PIT.
SOIL PIPE	A soil pipe is any pipe which conveys the discharge of water closets, urinals, or fixtures having similar functions, with or without the discharge from other fixtures, to the building drain or building sewer.
STACK	A stack is the vertical main of a system of soil, waste, or vent piping.
STORM DRAIN	See Building Storm Drain.
STORM SEWER	A storm sewer is a sewer used for conveying rain water, surface water, condensate, cooling water, or similar liquid wastes, exclusive of sewage and industrial waste. Also known as SEWER.
SUBSOIL DRAIN	A subsoil drain is a drain which receives only subsurface or seepage water and conveys it to a place of disposal.
SULLAGE	The discharge from wash basins, sinks and similar appliances, which does not contain human or animal excreta.
SUMP	A sump is a tank or pit which receives sewage or liquid waste, located below the normal grade of the gravity system, and which must be emptied by mechanical means.
SUPPORTS	The supports, hangers, and anchors are devices for supporting and securing pipe and fixtures to walls, ceilings, floors, or structural members.

TRAP	A trap is a fitting or device so designed and constructed as to provide, when properly vented, a liquid seal which will prevent the back passage of air without materially affecting the flow of sewage or waste water through it.
TRAP SEAL	The trap seal is the maximum vertical depth of liquid that a trap will retain, measured between the crown weir and the top of the dip of the trap.
VERTICAL PIPE	A vertical pipe is any pipe or fitting which is installed in a vertical position or which makes an angle of not more than 45 degrees with the vertical.
WASTE PIPE	A waste pipe is a pipe which conveys only liquid waste free of fecal matter.

7.4 Rainwater Harvesting Requirements

7.4.1 General

Every building proposed for constructing on plots having extent of 300 sqm or above shall have facilities for conserving and harvesting rainwater.

7.5 Rainwater Harvesting Plans

7.5.1 Requirement of Permit

Rainwater harvesting and drainage system shall not be installed until a permit for such work has been issued by the Building Authority for existing (only for addition or for alteration) or new building or for any other premises.

7.5.2 Application for Permit

An application for a permit for rainwater harvesting and drainage work shall be made on a prescribed form (see Appendix Q) by the licensed plumber and the owner, or by his appointed person or agent to install all or a self-contained or workable part of such work. The application shall accompany building rainwater harvesting and drainage plans and adequate description of the proposed rainwater harvesting and drainage installation in a drawing (drawn to a scale not less than 1:100) with the following details:

- (a) Plan of the building and site lay out;
- (b) Rainwater harvesting;
- (c) Ground recharging system;
- (d) Storm drainage system;
- (e) Catchment areas;

- (f) Materials, sizes and gradients of all proposed piping;
- (g) The position of manhole, rainwater pipe, gutters, rainwater inlets, etc. in the premises and their connection with storm sewer system or surface waters; the following colours may be used to indicate sewers, rainwater pipes and existing works:
- | | | |
|---|---|--------|
| Proposed storm sewers and disposal pipes: | - | violet |
| Existing network: | - | black |
- (h) The slope of catchments.

7.5.3 In addition to rainwater harvesting and drainage plan a separate site plan of the building shall be submitted with the following particulars:

- (a) Adjoining plots and streets with their identification;
- (b) The position and invert level of the storm sewers, (if any), surface drain water and the direction of flow in it
- (c) The level of the proposed drainage pipe connecting to the storm sewers (if any);
- (d) The position and layout of private storm drainage system (in absence of public storm sewers); and
- (e) The alignment, size and gradients of all harvesting and drainage piping.

7.5.4 For high rise and public buildings, design calculations and specifications for various items of the work involved shall be submitted along with the drawings.

7.5.5 Permits and Approvals

The building official shall examine or cause to be examined all applications for permits and, amendments thereto within 45 days. If the application does not conform to the requirements of all pertinent laws, such application shall be rejected in writing, stating the reasons therefore. If the proposed work satisfies all the Code requirements, the Authority shall issue a nontransferable permit.

7.6 Licensing of Plumber

7.6.1 License Requirement

No individual, partnership, corporation or firm shall engage in the business of installation, repair or alteration of rainwater harvesting and drainage work without obtaining a license from the Authority.

7.6.2 Examination and Certification

The Building Authority shall establish a plumbers' examination board. The board will determine the requirements for the qualification and procedures for examination of applicants for license. The Authority will issue license to such applicants who meet the qualifications therefore and successfully pass the examination conducted by the board.

7.6.3 Annulment of License

The license of a licensed plumber may be nullified by the Building Authority, if it is proved that a plumbing work has been completed and certified by the licensed plumber violating the provisions of this Code deliberately setting aside the approvals given in the permit or without receiving the permit from the Building Authority.

7.7 Rain-Water Harvesting**7.7.1 General**

Rainwater can be conserved and used in all useful purposes related to use of water. The amount of rain water to be conserved depends upon the purpose of use, rainfall intensity at the locality and the available catchments from where rainwater shall be collected. Rainwater can also be used for artificial ground water recharging. Two major aspects of rainwater harvesting are as follows: (i) Roof top rain-water harvesting, and (ii) Artificial ground water recharge.

7.8 Roof Top Rainwater Harvesting

Water can be collected through roof gutters and rainwater down pipes. Provision shall be made to divert the first rainfall after dry spell to avoid dust, soot, and leaves etc. in the water to be collected into the water tank. The capacity of water tank should be enough for storing water required for consumption between 2 dry spells.

7.8.1 Precautions in Rainwater Harvesting

Following precautions shall be taken:

- (a) No sewage or waste water should be admitted into the system.
- (b) Wastewater from areas likely to have oil, grease or other pollutants shall not be connected to the system.
- (c) Each rainwater seepage well shall have an inlet chamber with a silt trap to prevent any silt from finding its way into the sub-soil water.
- (d) The wells should be terminated at least 5 m above the natural static sub-soil water at its highest level so that the incoming flow passes through the natural ground condition and prevents contamination hazards.
- (e) No recharge structure or a well shall be used for drawing water for any purpose.

7.8.2 Qualifying Rainwater for Harvesting.

Rainwater shall be treated adopting following methods mentioned according to the purpose of use:

- (a) For using rainwater in drinking, cooking, washing utensils bathing and ablution it shall be disinfected along with filtration.
- (b) For cloth washing, floor washing, fountain, water fall cascade etc., rainwater shall be filtered.
- (c) For using in sprinkler firefighting, air conditioning etc. sedimentation of suspended particles will be required.
- (d) For toilet flushing, gardening, cleaning artificial ground, parking lots etc. screening floating materials are needed.

7.8.3 Catchments area for Collecting Rainwater

Rainwater can be collected from following built up areas for harvesting:

- (a) Roof top surfaces
- (b) External walls and other vertical surfaces
- (c) Balconies, sunshades etc.
- (d) Metal surface of play grounds, open yards etc.

7.8.4 Determining Catchment Area

For flat surface, the catchment area is its plan area plus 50 percent of the adjoining vertical wall contributing rainwater accumulation on the concerned catchment. See Appendix U.

For sloping roof, catchment is considered to be the actual inclined roof area.

7.8.5 Storing Rainwater

Where rainwater will be used for domestic purpose, rainwater from roof or terrace may be led straight from conductor (or leader) to one or more storage tanks. Storage tanks shall be provided with ventilating covers. An arrangement shall be made in the rainwater leader to divert the first washings from the roof or terrace catchments as they will contain more undesirable materials. The open end of all pipes shall be covered with mosquito (insect) proof wire net.

7.8.6 Flushing out First Rainwater

Before storing initial rainwater, just after starting raining, shall be drained out for a period as mentioned below.

<u>Location</u>	<u>Time</u>
Dhaka metropolitan area	20 min
Sylhet	15 min
Chittagong	15 min
Other urban areas	15 min

7.8.7 Precautions for Rainwater Storage

Following precautionary measures shall be taken for rainwater storage.

- Storage tank shall be made water tight in all respect.
- Tank shall always be kept covered.
- Regular cleaning at least once a year, preferably at end of dry periods, shall be done.
- Disinfection shall be done after cleaning operation.
- Tank shall be ventilated and vent pipe shall be covered by mosquito net.
- The tank must have an overflow pipe leading to a natural water course.
- If raw rainwater and potable water is to be stored in the same storage tank separated by a separating wall, then the separating wall shall have no openings.

7.8.8 Rainwater Treatment

For portable systems, a plain galvanized roof or a metal roof with epoxy or latex paint is recommended. Composite or asphalt shingles are not advisable, to improve water quality, disinfection shall be done in the following way.

7.8.8.1 Chlorination

Chlorine must be present in a concentration of 1 ppm to achieve disinfection. Liquid chlorine, in the form of laundry bleach, usually has 6 percent available sodium hypochlorite. For disinfection purposes, 2 fluid ounces ($\frac{1}{4}$ cup) must be added per 1,000 gallons of rainwater. Bleach products, however, not labeled cannot be used in water treatment. A purer form of chlorine, which comes in solid form, is calcium hypochlorite, usually with 75 percent available chlorine. At that strength, 0.85 ounces by weight in

1,000 gallons of water would result in a level of 1 ppm. Chlorine contact times are shown in Table 8.7.1. To filter out Giardia and Cryptosporidium cysts, an absolute 1-micron filter shall be used.

Table 8.7.1: Contact Time with Chlorine

Water pH	Water temperature		
	50°F or warmer	45°F	40°F or colder
	Contact time in minutes		
6.0	3	4	5
6.5	4	5	6
7.0	8	10	12
7.5	12	15	18
8.0	16	20	24

7.8.9 Determining Volume of Rainwater Storage

Determining volume of rainwater storage

$$\text{Rainwater storage volume in m}^3 = D \times N \times D_p / 1000 + \text{Floating}$$

Where, D = Rainwater demand In liter per capita per day.

N = Population number.

D_p = Number of days for which water will be stored. Consider 90 days for drinking, cooking, utensils cleansing, bathing and ablution purposes; 210 days for other purposes.

7.8.10 Sizing of Rainwater Down Piping

The size and number of vertical leaders or rainwater down pipes shall be based on the maximum projected roof area according to Table 8.7.2. Minimum two drains and vertical leaders shall be provided for any independent roof surface. The size of semi-circular gutter shall be based on maximum projected roof area according to Table 8.7.3.

7.8.11 Inlet of Leaders

Inlet of leaders on any open surfaces shall be provided with dome shaped gratings. Size of the Inlet of any vertical leader shall be one size bigger than the size of the corresponding vertical leader.

7.8.12 Design of Rainwater Distribution System

The design of rainwater distribution piping shall be in accordance with Sec 5.10 of Chapter 5.

7.9 Artificial Ground Water Recharge

7.9.1 General

Storm runoff should be used for augmentation of ground water reservoir where ground water depletion rate is more than one meter per year. The natural movement of surface water can be modified by constructing recharge structures, Figure 8.7.1, in order to attain the following objectives:

- Enhancement of sustainable yield in areas where there is over development and depletion of the aquifers.
- Conservation and storage of excess underground water in the aquifers.
- Improvement of the quality of the existing ground water through dilution.
- Maintaining the natural balance of the ground water and its usage as the rain-water is a renewable supply source providing constant, dependable and safe water supply.

Table 8.7.2: Size of Vertical Leaders*

Size of Leader ** (mm)	Maximum Projected Roof Area and Flow (m ²)	(l/min)
50	202	87
65	367	155
75	598	253
100	1287	544
125	2336	986
150	3790	1602
200	8180	3450

* This Table is based upon a maximum rainfall of 25 mm per hour for a 1-hour duration. The figure for drainage area shall be adjusted to local conditions (Appendix U).

** The equivalent diameter of square leader will be the diameter of that circle which can be inscribed within the cross-sectional area. The equivalent diameter of the rectangular leader will be the short dimension of the rectangular leader. However, the ratio of width to depth of rectangular leader shall not exceed 3:1.

Table 8.7.3: Size of Semicircular Roof Gutters*

Dia of Gutter (mm)	Maximum Projected Roof Area for Gutter of Various Slopes							
	5 mm per m		10 mm per m		20 mm per m		40 mm per m	
	m	l/min	m ²	l/min	m ²	l/min	m ²	l/min
75	61	25	87	36	123	51	174	73
100	130	55	185	77	260	110	370	155
125	227	96	320	136	455	192	645	273
150	350	148	495	210	700	296	1010	425
175	503	210	710	300	1000	425	1420	600
200	725	307	1020	430	1300	610	2040	862
250	1300	555	1850	785	2610	1110	3650	1540

* Table 8.7.4 is based upon a maximum rainfall of 25 mm per hour for 1-hour duration. The figure for drainage area shall be subject to local conditions in accordance with Appendix U.

7.9.2 Designing Recharge Pit

Volume of recharge pit shall be on the basis of maximum intensity of rainfall in a shorter period of at least 15 minute. It is about one fourth peak hourly rainfall

$$\text{Capacity of recharge tank} = A l_s f / F$$

Where,

A = Catchments area

l = Intensity of rainfall in 15 minutes

f = Runoff co-efficient and

p = Porosity of filter bed = 0.5

Large dry well can be constructed in accordance with the requirements for seepage pit (Sec 6.9.15). However, for small dry wells handling limited quantities of rainwater, the pit may consist of a 1 m long 0.45 m diameter pipe filled with crushed bricks stone.

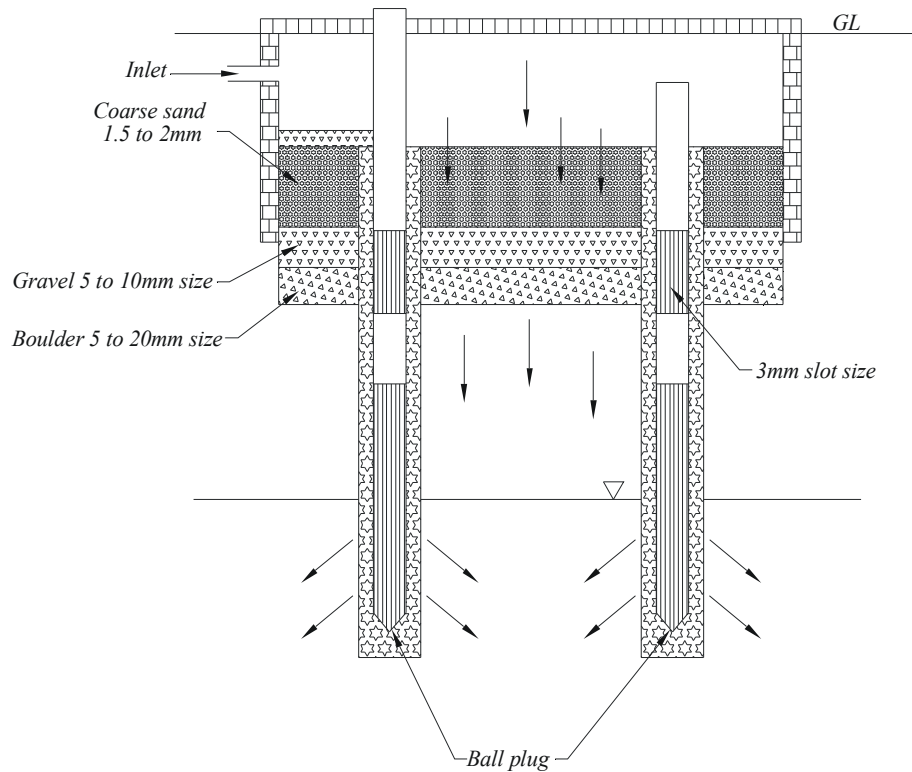


Figure 8.7.1. Artificial ground water recharge structure

7.10 Drainage and Sanitation Requirement

7.10.1 General

The object of storm water drainage is to collect and carry, the excess rain-water accumulating within the premises of the building, for suitable disposal. In rainwater drainage system there shall be safeguard against fouling, deposition of solids and clogging and with adequate inspection chambers so arranged that the drains may be readily cleaned without the risk of health hazard.

7.10.2 Design Factors

Estimation of the quantity of storm water shall be based on the following factors:

- (a) Imperviousness of the surface
- (b) Ground slope and time of concentration
- (c) Intensity of the rainfall for a design period and
- (d) Duration of the rainfall.

7.10.3 Imperviousness of the Surface

The percentage of imperviousness of the drainage area may be obtained from available data for a particular area. In the absence of such data, the following values may serve as a guide:

<u>Type of area (percent)</u>	<u>Imperviousness factor</u>
Commercial and industrial areas	70-90
Residential areas (high density)	60-75
Residential areas (low density)	35-60
Parks and underdeveloped areas	10-20

7.10.4 Time of Concentration

Time of concentration to reach the farthest point of any drainage system or the outfall under consideration should be considered between 5 min to 30 min.

7.10.5 Intensity of the Rainfall

Rainwater Intensity data for the locality of the building shall be studied to arrive at the design parameters for rainwater harvesting in accordance with Appendix R.

7.10.6 Rainwater Disposal

Rainwater from roof or from building premises shall not be discharged into septic tank. This shall be drained into storm sewer or combined sewer system where available or into private disposal methods, water course or dry well, Figures 8.6.18 and 8.6.19 of Chapter 6 Part 8.

7.10.6.1 Individual rain water traps shall be installed on the rainwater drain branch serving each leader or a single trap shall be installed in the main rainwater drain (building storm drain) just before its connection with the combined building sewer, main drain or public sewer.

7.10.6.2 No traps shall be required for rainwater drains which will be used for rainwater collection and connected to a sewer draining rainwater exclusively.

7.10.6.3 Subsurface drainage pipings for rainwater drainage shall not be less than 100 mm in diameter. The subsoil drainage system shall be protected by an accessibly located backwater valve in case the building is subject to backwater or flooding. Subsoil drains shall discharge to a trapped area drain, sump, dry well or an approved location above grade.

7.10.6.4 Rainwater pipes shall not be used as soil, waste or vent pipes.

7.10.6.5 All roof areas, except those draining to hanging gutters, shall be equipped with roof drains with strainers extending not less than 100 mm above the surface of the roof and shall have an available inlet area not less than two times the area of the leader to which the drain will be connected.

7.10.6.6 It is recommended to have more than one rainwater drainage pipe for primary roof drainage system to minimize blockage.

7.10.6.7 It is recommended to provide secondary rainwater drainage system at a suitable elevation from the roof that has been considered in the calculation of rainwater load to design the building structure. The secondary drainage system shall be a separate drainage piping up to a storm sewer or private waste (rainwater) disposal system. The size of secondary rainwater drainage piping shall not be less than the size required for primary rainwater drainage piping.

7.10.6.8 French drains may be employed as surface water drains for drainage of unpaved surfaces. Construction of French drains (if used) shall be in accordance with established engineering practices.

7.10.6.9 The design of such system shall be on the basis of location with respect to wells or other sources of water, soil permeability, ground water elevation, area available and maximum occupancy of the building.

7.11 Materials and Appliances

The piping, fixtures and equipment to be used for rainwater harvesting and drainage system shall be in accordance with Sec 6.7 in Chapter 6.

7.12 Construction of Rainwater Storage Tank

The construction of storage tanks for rainwater storage shall be in accordance with Sec 5.9 in Chapter 5 Part 8.

7.13 Installation and Construction of Rainwater Harvesting and Drainage System

7.13.1 All junctions and joints of rainwater harvesting and drainage piping shall be watertight.

7.13.2 Roof gutters shall be of suitable material of required thickness. All joints shall be watertight.

7.13.3 The depth of cover shall be in accordance with Sec 6.9.9 Chapter 6 Part 8.

7.13.4 The pipe shall be laid to even gradients and change of gradient shall be combined with an access point Sec 6.10.2 Chapter 6 Part 8. However, access points shall be provided only if blockages could not be cleared without them.

7.13.5 The joints and connection in drainage and venting system shall be gastight and watertight for the pressures required by the test, with the exception of those portions of perforated or open joint piping which will be installed for the purpose of collecting and conveying ground or seepage water to the underground storm drains.

7.13.6 Piping in rainwater drainage and harvesting system shall be installed without undue strains and stresses and provision shall be made for expansion, contraction and structural settlement. Vertical piping shall be secured at sufficiently close intervals to keep the pipe in alignment and carry the weight of the piping and its content. The horizontal piping shall be supported at sufficiently close intervals to keep it in alignment and to prevent sagging.

7.14 Hangers and Support

The piping, fixtures and equipment used for rainwater harvesting and drainage system shall be provided with sufficient hangers and support in accordance with Sec 5.17 in Chapter 5 Part 8.

7.15 Pipe Joints

The joints between different piping and fittings shall conform to the standards in accordance with Sec 5.17 in Chapter 5 Part 8.

7.16 Protection Against Rodent

Installation of pipes through any walls ceilings etc. shall be made rodent proof in accordance with Sec. 6.9.8 of Chapter 6 Part 8.

7.17 Gradient of Pipes

Lesser slope of rainwater drainage pipe shall be provided. The computed velocity in the storm water drains shall not be less than 0.6 m per second. The maximum recommended velocity shall be 2.5 m per second. For drain pipes to be used for recharging the flow velocity should be 0.6 m per second.

7.18 Inspection Chambers and Manholes

Inspection chambers and manholes shall Incorporated and constructed in accordance with 6.9.7.4 of Chapter 6 Part 8.

7.19 Bedding and Backfilling

The operation of bedding and backfilling shall be in accordance with Sec. 6.9.9 of Chapter 6 Part 8.

7.20 Design of Rainwater or Storm Water Drainage Piping

Designing of rainwater down pipe and storm water drainage pipe includes determining the number of rainwater down pipe and sizes and determining the size of drain pipes according to the fall of drain pipe.

7.21 Sizing and Finding the Number of Rainwater Drainage Piping

7.21.1 The size and number of vertical leaders shall be based on the maximum projected catchment area according to Table 8.7.2. Minimum two numbers of roof drains and vertical leaders shall be provided for any independent roof surface.

7.21.2 Sizing of Storm Water Drainage Piping

The size of building storm drain, storm sewer or any of their horizontal branches shall be based on the maximum catchment area including projected roof or paved area to be drained in accordance with Table 8.7.4. The size of semi-circular gutter shall be based on maximum projected roof area according to Table 8.7.3.

Table 8.7.4: Size of Horizontal Building Storm Drains and Building Storm Sewer *

Diameter of Drain (mm)	Maximum Catchment Area and Flow for Various Slopes					
	10 mm per m		20 mm per m		40 mm per m	
	m ²	l/min	m ²	l/min	m ²	l/min
75	299	125	422	177	599	252
100	668	288	965	406	1370	577
125	1215	515	1715	725	2430	1030
150	1950	823	2745	1157	3900	1645
200	4185	1765	5940	2500	8380	3540
250	7550	3185	10650	4500	15100	6370
300	12140	5100	17140	7236	24280	10250
375	21700	9120	30600	12900	43400	18300

* Table 8.7.3 is based upon a maximum rainfall of 25 mm per hour for 1-hour duration. The figure for drainage area shall be adjusted to local conditions in accordance with Appendix U.

7.22 Inspection, Testing and Completion Certificate

The inspection, testing and completion certification of rainwater harvesting and drainage system or part of existing system shall be in accordance with Sec 6.15 Chapter 6 Part 8.

7.23 Guide to Maintenance

The maintenance of rainwater harvesting and drainage and system shall be in accordance with Sec 6.16 Chapter 6 Part 8.

7.24 List of Related Appendices

Appendix R One-hour Rainfall

Appendix U Determining Catchments Area for a Flat Surface

PART VIII
Chapter 8
Fuel Gas Supply

8.1 General

8.1.1 Scope

8.1.1.1 This Chapter provides the requirements aimed at safeguarding life and property in nonindustrial gas piping systems for use with fuel gases such as natural gas (NG) and liquefied petroleum gas (LPG) in the vapour phase used for fuel or lighting purposes in consumers' premises.

8.1.1.2 This Chapter does not cover the safety requirements and rules for gas burning appliances. The requirements of National Fuel Gas Code - 2009 edition (NFPA-54/ANSI Z223.1) and NFPA 58-2008 edition and International Fuel Gas Code-2009 of the USA shall apply for such appliances.

8.1.1.3 The requirements of this Chapter do not apply to gas piping systems for industrial installation and applications.

8.1.1.4 This Chapter covers the aspects of design, fabrication, installation, test, operation, inspection and maintenance of gas piping systems from the point of delivery to the connections with each utilization device. The point of delivery is defined in this Chapter as the outlet of the service regulator or the service shutoff valve where there is no meter.

8.1.1.5 Piping systems covered here are limited to a maximum operating pressure of 3.45 kPa (14 inches of water column or ½ psig).

8.1.1.6 While applying the provisions of this Chapter, reference should also be made to the manufacturers' instructions, gas supply company's regulations and other applicable codes and standards listed in this Chapter or required by the authority having jurisdiction.

8.1.2 Terminology

This Section provides definitions of terms used in this Chapter of the Code. Where terms are not defined in this Chapter, they shall be defined using their ordinarily accepted meanings such as the context implies. The definitions in the Chapter are the same as used in National Fuel Gas Code-2009 edition (NFPA-54/ANSI Z223.1), International Fuel Gas

Code-2009 and Liquefied Petroleum Gas Code-2008 (NFPA-58) and National Building Code of India-2005.

APPLIANCE	Any device that utilizes gas as a fuel or raw material to produce light, heat, power, refrigeration, or air conditioning.
APPLIANCE VALVE	A device that will shut off the gas supply to burner(s)
APPROVED	Acceptable to the authority having jurisdiction
AUTHORITY HAVING JURISDICTION (AHJ)	An organization, office, or individual responsible for enforcing the requirements of a code or standard, or for approving equipment, materials, and installation, or a procedure.
BRANCH LINE	Gas piping that conveys gas from a supply line to the appliance
BURNER/COOKERS	A device for the final conveyance of gas, or a mixture of gas and air, to the combustion zone.
CONCEALED GAS PIPING	Gas piping that, when in place in a finished building, would require removal of permanent construction to gain access to the piping.
CONSUMER'S/CUSTOMER'S CONNECTION	Piping tapped on the riser to supply gas to individual customer/consumer
CYLINDER	A portable container designed, fabricated, tested and marked (or stamped) in accordance with a recognized standard/code such as ASME, or the regulations of the US Department of Transportation (DOT) used for transporting or storing LPG. The maximum size permitted inside the building is 320 kg water capacity.
DIVERSITY FACTOR	Ratio of the maximum probable demand to the maximum possible demand.
DRIP	The container placed at a low point in a system of piping to collect condensate and from which it may be removed.
EQUIVALENT	Nothing in this Code is intended to prevent the use of system, methods or device of equivalent or superior quality, strength, fire resistance, effectiveness, durability and safety over those prescribed by this Code. However, technical documentation shall be submitted to the authority having jurisdiction to demonstrate equivalency; and the proposed method, system or device shall be approved for the intended use by the same authority.

FUEL GAS	A natural gas, manufactured gas, liquefied petroleum gas or mixtures of the gases (This Chapter only recognizes natural gas and LPG as fuel gas).
GASES	Include natural gas, manufactured gas, liquefied petroleum (LP) gas in the vapor phase, liquefied petroleum gas-air mixtures and mixtures of these gases, plus gas-air mixtures within the flammable range, with the fuel gas or the flammable component of a mixture being a commercially distributed product.
GAS FITTER	An employee of the gas supplying company
GAS MANIFOLD	The conduit of an appliance that supplies gas to the individual burner(s).
LABELED	Equipment or materials to which has been attached a label, symbol or other identifying mark of an organization that is acceptable to the authority having jurisdiction and concerned with product evaluation, that maintains periodic inspection of production of labeled equipment or materials, and by whose labeling the manufacturer indicates compliance with appropriate standards or performance in a specified manner.
LIQUEFIED PETROLEUM GAS (LPG)	Liquefied petroleum gas composed predominantly of propane, propylene, butanes or butylenes or mixtures thereof that is gaseous under normal atmospheric conditions but is capable of being liquefied under moderate pressure at normal temperatures.
LISTED	Equipment, materials or services included in a list published by an organization that is acceptable to the authority having jurisdiction and concerned with evaluation of products or services, that maintains periodic inspection of production of listed equipment or materials or periodic evaluation of services, and whose listing states either that the equipment, materials, or service meets appropriate designated standards or has been tested and found suitable for a specified purpose.
METER	An instrument installed to measure the volume of gas delivered through it.
OUTLET	The point at which gas-fired appliance connects to the gas piping system.
PILOT	A small flame that is utilized to ignite the gas at the main burner or burners.

PIPE	Rigid conduit of iron, steel, copper, brass, aluminum, or plastic.
PIPING SYSTEM	All piping, valves and fittings from the outlet of the point of delivery from the supplier to the outlets of the equipment shutoff valves.
PRESSURE REGULATOR	Equipment placed in a gas line for reducing, controlling, and maintaining the pressure in that portion of the piping system downstream of the equipment.
PRESSURE TEST	An operation performed to verify the gastight integrity of gas piping following its installation or modification.
PURGE	To free a gas conduit of air or gas, or a mixture of gas and air.
QUALIFIED AGENCY	An individual, firm, corporation, or company that either in person or through a representative is engaged in and is responsible for (a) the installation, testing, or replacement of gas piping or (b) the connection, installation, testing, repair, or servicing of appliances and equipment; that is experienced in such work; that is familiar with all precautions required; and that has complied with all the requirements of the authority having jurisdiction.
RISER	A vertical pipe supplying fuel gas
SAFETY SHUTOFF DEVICE	A device that will shut off the gas supply to the controlled burner(s) in the event the source of ignition fails. This device may interrupt the flow of gas to main burner(s) only or to pilot (s) and main burner (s) under its supervision.
SERVICE METER ASSEMBLY	The piping and fittings installed by the serving gas supplier to connect the inlet side of the meter to the gas service and to connect the outlet side of the meter to the customer's house or yard piping.
SERVICE REGULATOR	A pressure regulator installed by the serving gas supplier to reduce and limit the service line gas pressure to delivery pressure.
SERVICE SHUTOFF VALVE	A valve, installed by the serving gas supplier between the service meter or source of supply and the customer piping system, to shut of the entire piping system.
SHALL	Indicates a mandatory requirement
TUBING	Semi rigid conduit of copper, steel, aluminum, CSST (corrugated stainless steels tubing) or plastic

VALVE	A device used in piping to control the gas supply to any section of a system of piping or to an appliance.
VENT	A passageway used to convey flue gases from appliances or their vent connectors to the outdoors.
WATER HEATER	An appliance for supply hot water for domestic or commercial purpose.

8.1.3 General Precautions

8.1.3.1 Turn Gas Off: All gas piping work or gas appliance installation shall be performed with the gas turned off to eliminate hazards from leakage of gas.

8.1.3.2 Notification of Interrupted Service: It shall be the responsibility of the installing agency, when if the gas supply is to be turned off, to notify all affected consumers.

8.1.3.3 Before Turning Gas Off: Before turning off the gas to premises for the purpose of installation, repair, test, inspection, replacement or maintenance of gas piping or appliances, all burners shall be turned off. When two or more consumers are served from the same supply system, precautions shall be taken to ensure that only supply to the concerned consumer is turned off.

8.1.3.4 Checking for Gas Leaks: Soap and water solution or other material approved for the purpose, shall be used in locating gas leakage. Use of matches, candles, flames or other sources of ignition shall be prohibited for this purpose.

8.1.3.5 Use of Lights: Artificial illumination used in connection with a search for gas leakage shall be restricted to battery operated flashlights (preferably of the safety type) or approved safety lamps. In searching for leaks, electric switches should not be operated. If electric lights are already turned on, they should not be turned off.

8.1.3.6 Working Alone: An individual shall not work alone in any situation where working practice desires that two or more persons are necessary to carry out the work safely.

8.1.3.7 Handling Liquid from Drips: Liquid which is removed from a drip in an existing gas piping shall be handled with proper precautions, and shall not be left on the consumers' premises.

8.1.3.8 No Smoking: When working on piping which contains or has contained gas, smoking shall be prohibited.

8.1.3.9 Handling of Flammable Liquids: Flammable liquids used by the installer shall be handled with proper precautions and shall not be left within the premises from the end of one working day to the beginning of the next.

8.1.3.10 Work Interruption: When interruptions in work occur, the system shall be left in a safe and satisfactory condition.

8.1.3.11 Certain requirements related to work on the gas supply system are listed in Appendix V.

8.1.4 Notification of Completion

8.1.4.1 When regulations so require, the completion of installation shall be notified to the gas supply company or the Authority.

8.2 Gas Piping Installation

8.2.1 Piping Plan and Approval

8.2.1.1 Plans for installation of gas piping system and gas appliances shall be prepared in accordance with requirements of the gas supply company and the Authority. Necessary approvals shall be obtained from the gas supply company and the Authority before installation of the gas piping system and the appliances. (See Appendix W).

8.2.1.2 The plan shall include proposed location of the piping, layout and sketch of the piping system, sizes of different branches, and present and future gas demands.

8.2.1.3 Approved plans shall bear the authorized seal and signatures of the gas supply company and the Authority.

8.2.2 Size of Piping to Gas Appliances

8.2.2.1 Gas piping shall be of such size and so installed to ensure adequate supply of gas to meet the maximum demand without undue pressure drop between the meter, or service regulator when there is no meter, and the appliance or appliances.

8.2.2.2 The size of gas piping depends upon the following factors:

8.2.2.3 Allowable pressure drop from meter or service regulator, when there is no meter, to appliance

8.2.2.4 Maximum gas consumption to be provided

8.2.2.5 Length of piping and number of fittings

8.2.2.6 Specific gravity of the gas

8.2.2.7 Diversity factor

8.2.2.8 The size of each gas piping system shall be determined by standard engineering methods acceptable to the gas supply company and the Authority.

8.2.2.9 Gas pipes smaller than 12 mm in diameter shall not be used.

8.2.2.10 Straight lengths of piping shall be used as far as practicable. Where there are bends in the pipeline, or as approved by the gas supply company, the inside radius of a bend shall be not less than 6 times the outside diameter of the pipe.

8.2.3 Acceptable Piping Materials

8.2.3.1 Piping material shall be one of the materials listed in Table 8.8.1 conforming to the corresponding standards, or other materials as may be approved by the gas supply company or the Authority. Cast iron pipe shall not be used.

Table 8.8.1 Fuel Gas Pipe Materials

Material	Standards
Black steel pipe*	ASTM A106
Galvanized steel pipe*	ASTM A53
Wrought steel and wrought iron pipe*	ANSI B36.10 M
Corrugated stainless steel tubing	ANSI LCI/CSA 6.26
Copper or copper-alloy tubing (Type K or L)	ASTM B88; ASTM B280
Aluminium pipe and tubing	ASTM B210; ASTM B 241
Plastic pipe and tubing	ASTM D2513
* Minimum Schedule 40	

8.2.3.2 Fittings shall be of an approved type and material for gas piping systems accepted to the gas supply company. Bushings shall not be employed.

8.2.3.3 All joints and connections shall be of an approved type and material for gas piping system acceptable to the gas supply company. Joints and connections shall be gas tight at the test pressure. (see Sec 8.2.9.3 and 8.2.9.4)

8.2.3.4 Flexible metal pipes or heavy rubber pressure tubing acceptable to the gas supply company may be used only for direct connections to burners.

8.2.4 Fabrication of Piping for Installation

8.2.4.1 Gas pipe or tubing and fittings shall be clean and free from cutting burrs and defects in structure or threading and shall be thoroughly brushed with chips and scale blown. Defects in pipe or tubing or fittings shall not be repaired when defective pipe, tubing or fittings have been identified. The defective material shall be replaced.

8.2.4.2 Pipe, tubing, fittings and valves removed from any existing installation shall not be used again until they have been thoroughly cleaned, inspected and ascertained to be equivalent to new material.

8.2.4.3 Metallic pipes with threads which are damaged or defective shall not be used.

8.2.4.4 Metallic pipes shall be threaded in accordance with approved standard acceptable to supply company.

8.2.4.5 When used in a corrosive environment, metallic pipes and fittings shall be protected with corrosion resistant coating.

8.2.4.6 For any thread joint proper sealant shall be used on the made threads only.

8.2.4.7 Joints and joining compounds if used in LPG installation shall be resistant to the action of liquid petroleum gas.

8.2.5 Installation of Gas Pipes

8.2.5.1 Installation, repair and replacement of gas piping or appliances shall be performed only by a qualified installing agency or gas fitter.

8.2.5.2 Protection of Piping: Piping shall be buried to a minimum depth of 1 m covered in a manner so as to protect the piping from physical damage. It shall be protected from physical damage when it passes through flower beds, shrub beds and other such cultivated areas.

8.2.5.3 Protection against Corrosion: Gas piping in contact with earth or other materials which will corrode the piping shall be protected against corrosion in an approved manner. When dissimilar metals are joined underground, an insulating coupling or fitting shall be used. Piping shall not be laid in contact with cinder or ash.

8.2.5.4 All the piping within the premises where it has to run on the wall shall be exposed and should not be in contact with wall to ensure that no corrosion takes place. Epoxy sealant or polyethylene conduit shall be used to ensure no contact of pipe with the wall in the situation of pipe crossing the wall. Uncoated threaded or socket welded joints shall not be used in piping in contact with soil or where internal or external crevice corrosion is known to occur.

8.2.5.5 Piping Through Foundation Wall: Underground gas piping, when installed below grade through the outer foundation or basement wall of a building, shall be either encased in a protective sleeve or protected by an approved device or method. The piping or sleeve shall be sealed at the foundation or basement wall to prevent entry of gas or water.

8.2.5.6 Piping Underground beneath Buildings: If the laying of gas piping underground beneath buildings cannot be avoided, the piping shall be encased in an approved conduit designed to withstand super imposed load. The conduit shall extend into a normally accessible portion of the building and, at the point where the conduit terminates in the building, the space between the conduit and the gas piping shall be sealed to prevent the entrance of gas from any possible leakage. The conduit shall extend at least 100 mm outside the building, be vented outdoors above finished ground level and be installed in such a way as to prevent the entrance of water and insects.

8.2.5.7 Building Structure: The building shall not be weakened by the installation of any gas piping. Existing beams or joists shall not be cut or notched.

8.2.5.8 Piping Supports: Gas piping in buildings, shall be supported with pipe hooks, metal pipe straps, bond or hangers of an approved type and material suitable for the size of piping, and of adequate strength and quality and located at specified intervals so that the piping cannot be moved accidentally from the installed position. Gas piping shall not be supported by other piping.

8.2.5.9 Piping Entrance to Buildings: When gas pipe enters a building through a wall or floor of masonry or concrete, it shall be sealed against the entrance of water, moisture or gas.

8.2.5.10 Piping in Floors: Piping in solid floors, such as concrete, shall be laid in channels in the floor suitably covered to provide access to the piping with a minimum damage to the building.

8.2.5.11 Single pipe without joints shall be used for wall crossing in any building.

8.2.5.12 Changes in direction of gas pipe shall be made by the use of approved fittings, factory bends or field bends. Field bends shall be made by employing approved procedures and equipment.

8.2.5.13 Gas piping inside any building shall not be run in or through an air duct, chimney or gas vent, ventilating duct or elevator shaft. Gas piping shall not be taken through inaccessible or concealed areas where its condition cannot be inspected and accumulation of gas due to undetected leakage may create a dangerous condition.

8.2.5.14 Provide Drips where Necessary: A drip shall be provided at any point in the line of pipe where condensate may collect. When condensation is excessive, a drip should be provided at the outlet of the meter where required by the authority or the gas supply company. This drip shall be so installed as to constitute a trap wherein an accumulation of condensate will shut off the flow of gas before it will runback into the meter. All drips installed shall be readily accessible to permit cleaning, inspection or emptying.

8.2.5.15 Cap All Outlets: Each outlet, including a valve or cock outlet, shall be firmly closed gas tight with a threaded plug or cap immediately after installation and shall be left closed until an appliance is connected thereto. Similarly, when an appliance is disconnected from an outlet and the outlet is not to be used again immediately, it shall be capped or plugged gas-tight. The outlet shall not be closed with tin caps, wooden plugs, corks or by other improvised means or objects. Use of a listed quick disconnect device is acceptable.

8.2.5.16 Prohibited Devices: No device shall be placed inside the gas pipe or fittings that will reduce the cross-sectional area or otherwise obstruct the free flow of gas.

8.2.5.17 Branch Pipe Connection: All branch pipe connections and outlets shall be taken from the top or sides of horizontal lines and not from the bottom.

8.2.5.18 Electrical Bonding and Grounding: The gas piping shall be electrically continuous throughout its length and properly earthed except in stretches where cathodic protection system is used for protection against corrosion. The piping shall not be used to ground any electrical equipment.

8.2.5.19 Distance from Electrical Wiring: The distance between the gas piping and electrical wiring system shall be at least 60 mm. They shall be securely fixed to prevent contact due to movement. The gas piping should be installed below the electrical wiring for heavier gas like LPG and for natural gas the piping should be above the electrical wiring.

8.2.5.20 Distance from Steam Piping: The gas piping and steam piping, if installed parallel, shall be at least 150 mm apart. The gas piping should preferably be installed below the steam piping.

8.2.5.21 Gas Piping to be Graded: All gas piping shall be graded not less than 1 in 750 to prevent accumulation of condensate or liquids in the line. All horizontal lines shall grade to risers, and from the risers to the meter, or service regulator when there is no meter, or to the appliance.

8.2.5.22 The gas piping shall be painted red in order to differentiate it from other piping. Where the piping is exposed to sun rays, it shall be painted silver gray.

8.2.5.23 Documentation shall be maintained for all gas supply installations. (See Appendix W).

8.2.6 Pressure Regulators

8.2.6.1 Where the pressure of gas supplied to domestic installation or other low pressure gas piping systems in buildings is in excess of 3.45 kPa, a gas pressure regulator of approved type and size shall be installed in the service pipe of each such system to prevent pressure in excess of 3.45 kPa from being introduced into such a building piping. If the building pipe is of welded construction the pressure regulator may be located upstream of the gas meter in each consumer's premises. In these cases, the gas pressure in the piping downstream of the gas pressure regulator shall not exceed 3.45 kPa.

8.2.6.2 If installed inside a building, the regulator shall comply with the following:

8.2.6.3 If any of the diaphragms of the regulator ruptures, the gas shall be directed to an outlet vent pipe made of brass or plastic in order to vent the gas out of the building. The vent pipe shall be installed about 1m above the topmost story of the building in open air. Means shall be employed to prevent water from entering the pipe and also to prevent blocking it by insects or other foreign bodies.

8.2.6.4 If the gas pressure at the outlet of the regulator falls below 50 percent of the operating gas pressure or rises above twice the operating pressure, the gas supply to the pressure regulator shall shut off.

8.2.6.5 In the event of malfunctioning of this safety device, a supplementary device shall connect the low pressure circuit to the vent pipe as soon as the exit pressure reaches 6.90 kPa.

8.2.6.6 The gas supply company shall ensure that the heating value and supply pressure of gas shall not exceed the stated values for the type of gas being supplied.

8.2.7 Service Shutoff Valves

8.2.7.1 Service shutoff valves shall be provided on all new services including replacements and shall be installed in a readily accessible location.

8.2.7.2 Service shutoff valves shall be located upstream of the meter if there is no regulator or upstream of the regulator if there is one.

8.2.7.3 All gas services installation operating at pressure greater than 3.45 kPa shall be equipped and with shutoff valve of approved type installed on the service pipe outside the building.

8.2.7.4 Underground shutoff valves shall be located in a covered durable kerb box, manhole, vault, or stand pipe which is designed to permit ready operation of the valve. The covers so provided shall be clearly marked "GAS".

8.2.7.5 Every gas outlet shall have an individual shutoff valve. The shutoff valve shall be accessible and adjacent to the appliance.

8.2.8 Existing Work

8.2.8.1 Nothing herein shall prohibit the continued use of an existing gas piping system without further inspection or test unless the Authority has reason to believe that defects which make the system dangerous to life or property exist.

8.2.9 Inspection of Services

8.2.9.1 No person shall use or permit the use of a new system or an extension of an old system of gas piping in a building or structure before the same has been inspected and tested to ensure that the system is safe and a certificate has been issued by the Authority. (See Appendix W).

8.2.9.2 Test of Piping for Tightness: Before any system of gas piping is finally put in service, it shall be carefully tested to ensure that it is gas tight and safe. Where any part of the system is to be enclosed or concealed, this test should precede the work of closing in. The test medium shall be air, nitrogen, carbon dioxide or an inert gas. OXYGEN SHALL NEVER BE USED.

8.2.9.3 Before appliances are connected, the piping systems shall be tested at a pressure of at least 159-mm mercury for a period not less than 10 minutes without showing any pressure drop. The source of pressure shall be isolated before the pressure tests are performed.

8.2.9.4 The Authority shall, within a reasonable time after being requested to do so, inspect and test the gas piping system that is ready for such inspection and test. If the system is found to comply with the requirements of inspection and test as laid down, it shall issue the certificate.

8.2.9.5 It shall be unlawful to supply gas in a building before the required certificate has been issued (see Sec 8.2.9.4 above), except that the Authority may give temporary permission for a limited time to supply and use gas before such an installation has been fully completed and the certificate issued.

8.2.10 Check of Leakage

8.2.10.1 Close All Gas Outlets: Before turning gas under pressure into any piping, all openings and outlets from which gas can escape shall be closed.

8.2.10.2 Check for Leakage: No matches, flames or other sources of ignition shall be used to check for gas leakage from meters, piping or appliance. Checking for gas leakage with soap and water solution shall be recommended (see Sec 8.1.3.4 and 8.1.3.5 also).

8.2.10.3 Checking for Leakage with Meter: Immediately after turning gas into the piping, the system shall be checked to ascertain that no gas is escaping. This may be checked by carefully watching the test dial of the meter to determine whether the gas is flowing through the meter. Under no circumstances shall a leakage test be made using a gas meter unless immediately prior to such test it has been determined that the meter is in operating condition.

8.2.10.4 Checking of Leakage not using a Meter: This may be performed by attaching to an appliance orifice, a manometer or equivalent device (gauge) so that it can be read in increments of 2.5 mm water column and momentarily turning on the gas supply and observing the gauging device for pressure drop with gas supply shutoff. No drop in pressure shall occur during a period of 3 minutes.

8.2.10.5 When Leakage is Indicated: If the meter test hand moves or a pressure drop on the gauge occurs, all appliances or outlets supplied through the systems shall be checked to ensure that they are shut off and do not leak. If they are shut off firmly there is a leak in the piping system. The gas supply shall be shut off until the necessary repairs have been made, after which the test specified in Sec 8.2.10.3 or Sec 8.2.10.4 above shall be repeated.

8.2.11 Purging

8.2.11.1 Purging All Gas Piping: After piping has been checked, all gas piping shall be fully purged. Piping shall not be purged into the combustion chamber of an appliance. A suggested method for purging the gas piping to an appliance is to disconnect the pilot piping at the outlet of the pilot valve.

8.2.11.2 Lighting Pilots: After the gas piping has been fully purged, all appliances shall be purged and the pilots lighted. The installing agency shall satisfy itself that all piping and appliances are fully purged and safe for use before leaving the premises.

8.2.12 Rules for Turning Gas On

8.2.12.1 A person, who is an employee of the gas supply company and authorized by the gas supply company, shall turn on the gas at a service shutoff valve or at any valve that controls the supply of gas to more than one consumer.

8.2.12.2 Gas shall not be turned on at any meter valve without specific permission from the gas supply company or the Authority if any of the following conditions are found:

8.2.12.3 If the gas piping, appliances or meter supply through the meter valve are known to leak or otherwise be defective;

8.2.12.4 If required inspection of the piping or appliance has not been performed;

8.2.12.5 If the gas supply company or the Authority has requested that the gas be left turned off;

8.2.12.6 If the meter valve is found shutoff for some reason not known to the gas fitter.

8.2.12.7 The gas shall not be turned on in the event of fire.

8.2.12.8 Gas shall not be turned on at any branch line valve if any of the conditions listed in Sec 8.2.12.2 above are found. Where a branch line valve is found closed, a gas fitter shall again turn the gas on at such valve only. If proper precautions to prevent leakage are taken and no other unsafe conditions are created thereby.

8.2.12.9 Gas shall not be turned on at either the meter valve or the service line unless all gas keys/ cocks or valves installed on all outlets in the piping system are closed or all outlets in the piping system are capped or plugged.

8.2.13 Rules for Shutting Off the Gas

8.2.13.1 The gas fitter shall put the gas off to any appliance, pipe or piping system and shall leave the gas turned off, until the cause for interruption of supply has been removed in any one the following cases:

8.2.13.2 If ordered to do so by the Authority;

8.2.13.3 If leakage of gas is found, which appears to be sufficient to cause fire, explosion or asphyxiation;

8.2.13.4 If an installation is found to be such as to seriously endanger life and property;

8.2.13.5 If any condition exists which threatens interruption of gas supply that may cause burner failure or otherwise lead to dangerous conditions.

8.2.13.6 Before turning off the gas at the meter, for the purpose of installation, repair, replacement, test, inspection or maintenance of piping or appliances, all burners and pilot valves on the premises supplied with gas through the meter shall be turned off and the meter test hand observed for a sufficient length of time to ascertain that there is no flow of gas through the meter. Where there is more than one meter on the premises, precautions shall be exercised to ensure that the concerned meter is turned off.

8.2.14 Provision for Meter Location

8.2.14.1 The meter location shall be such that the meter can be easily read and the connections are readily accessible for servicing. Location, space requirements, dimensions and type of installation shall be acceptable to the gas supply company and be approved by the same.

8.2.14.2 Meters shall be installed in such a way that there shall be no load transfer from the pipeline to the inlet/outlet of the meter.

8.2.14.3 Gas piping at multiple meter installations shall be clearly marked by a metal tag or other permanent means provided by the installing agency, designating the building or the part of the building being supplied.

8.3 Use of Liquefied Petroleum Gas (Lpg)

- (a) The cylinders used for the storage and transportation of liquefied petroleum gas (LPG) shall conform to the accepted standards approved by the Authority.
- (b) The handling, use, storage and transportation of liquefied petroleum gas in cylinders exceeding 500 ml of water capacity shall be done in accordance with the good practice approved by the Authority and the guidelines of the gas supply company.
- (c) The cylinders shall be marked as provided in the regulations, rules or code under which they are fabricated.

8.3.1 LPG Cylinder Installation

The following recommendations apply to installations in residential, commercial, industrial, educational and institutional premises.

8.3.1.1 Personnel engaged and responsible for the installation of cylinders, equipment and piping should understand the characteristics of LPG and be trained in good practice of handling, installing, inspection, test and maintenance of installation.

8.3.1.2 The joining compounds used in the piping system shall be resistant to the action of liquefied petroleum gas and shall be decided by the Qualified Installation Agency. Hemp and similar materials shall not be used at the joint. In any joint in which the thread provides a gas tight seal, joining compound shall be used on the male thread.

8.3.1.3 Fire extinguishers of dry power or carbon dioxide type conforming to accepted standards shall be provided in places where LPG cylinder installations are situated and shall be located near such installations. Two buckets filled with sand and two with water shall also be installed nearby. The guidelines of the LPG supply company and the Authority shall be followed in this respect. The number, type and size of the fire extinguishers shall be as follows:

For installation with LPG	Number	Type	Capacity
40 kg to 200 kg	2	Dry powder	10 kg
more than 200 kg upto 320 kg	2	Dry powder	10 kg

8.3.1.4 Liquefied petroleum gas shall not be transferred from the cylinders in which it is supplied to any other container.

8.3.2 Cylinder Location

8.3.2.1 Stationary Installations

8.3.2.2 Stationary installation not exceeding 40 kg of LPG may be installed indoors on any floor. Recommended minimum floor area per installation is 5 m².

8.3.2.3 Stationary installations each not exceeding 40 kg of LPG may be installed indoors on any floor within the same workspace provided the minimum distance between two such installations is 3 m. Recommended minimum floor area per installation is 5 m² and the aggregate of all such installations should not exceed 200 kg.

8.3.2.4 Stationary installation not exceeding 80 kg of LPG may be installed indoors on any floor provided the floor area per installation is not less than 12 m².

8.3.2.5 Stationary installations each not exceeding 80 kg of LPG may be installed indoors on any floor and within the same workspace provided the minimum distance between two such installations is 3 m. The Recommended floor area per installation is 12 m² and the aggregate quantity of all such installations should not exceed 200 kg.

8.3.2.6 Stationary installation not exceeding 320 kg of LPG may be installed indoors in an enclosed section of a building or a room reserved exclusively for this purpose and ventilated at low level directly to the outside air.

8.3.2.7 Stationary installation above 320 kg (200 kg in case provision as in (e) above is not possible) but not exceeding 1000 kg shall be installed outdoors on the ground level only. A minimum distance of 3 m shall be maintained between such an installation and any building, public place, roadways and other surroundings. The installation shall be protected against weathering by sun, rain, etc. and from tampering by unauthorized persons. A suitable shade of approved type and material may be provided for the purpose. Adequate ventilation at ground level to the outside air shall be provided. The distance between any two such installations shall be 3 m unless separated by a solid wall of fire resistant material up to at least 1 m above the height of the manifold valve.

8.3.2.8 The position of the cylinders shall facilitate: Changing and quick removal of any cylinder in case of necessity, and access to cylinder valve connections and regulating devices

8.3.2.9 Cylinders shall be placed upright with the valve uppermost.

8.3.2.10 Cylinders shall be placed on a firm and dry base such as concrete or brick floor. For outdoor installations the base shall be elevated.

8.3.2.11 Cylinders shall not be placed close to steam pipes or any other source of heat and shall be protected from the weather and direct sun. Cylinders shall be placed at a distance of 3 m from any other source of heat which is likely to raise the temperature of cylinders above the room temperature unless separated by metal sheet or masonry partition.

8.3.2.12 When cylinders are being connected or disconnected, there shall be no open flame or any source of ignition nearby and smoking shall be prohibited.

8.3.2.13 Cylinders shall not be installed below ground level and shall be at least 1 m away from drains, culverts or entrances and openings leading to cellars and other depressions in which gas might accumulate.

8.3.2.14 Cylinders shall not be installed at a place where they are likely to cause an obstruction, to be damaged or to be exposed to conditions likely to affect their safety.

8.3.2.15 Cylinders which have safety relief valve or similar devices incorporated in them shall be so positioned that if the relief devices operates escaping gas is not hazardous.

8.3.2.16 Portable Installations

8.3.2.17 When portability of cylinders is desired, the following requirements shall be met:

8.3.2.18 The sum total capacity of the cylinders connected to each manifold shall not exceed 80 kg of LPG. The total quantity of gas thus installed in a workspace shall not exceed 200 kg.

8.3.2.19 The regulator shall be connected directly to the cylinder valve or to a manifold which shall be connected to the cylinder valve by means of rigid connections to have the regulator firmly secured.

8.3.2.20 At any time the total quantity of gas at portable installations shall not exceed the limits in proportion to the floor area specified in Sec 8-3.2.1 (a) to (f).

8.3.2.21 If cylinders are mounted on a trolley shall be stable, where necessary the cylinders shall be secured to prevent them from falling.

8.3.3 Manifolds and Pressure Regulators

8.3.3.1 If pressure regulators, manifold headers, automatic change over devices, etc. are connected to cylinders by flexible or semi-flexible connectors, they shall be rigidly secured. Copper tube pigtailed and reinforced high pressure hoses are considered to be flexible or semi-flexible connectors for this application.

8.3.3.2 Pressure regulator fitted with a safety valve shall be either:

8.3.3.3 Installed in the open air or

8.3.3.4 Vented to the open air by means of a metal vent pipe connected to the safety valve discharge line.

8.3.3.5 Precautions shall be taken that safety valve outlets do not get blocked with dust or other substances.

8.3.3.6 Suitable line shutoff valves shall be provided with each appliance or burner when more than one appliance is connected to the gas supply. Both ends of the connection to portable appliances shall be firmly attached with clips. Hose shall be resistant to the action of LPG.

8.3.3.7 The manifold headers which do not have to be taken off in normal use should be brazed or welded using material conforming to approved standards and having a melting point not less than 540°C.

8.3.3.8 All materials, fittings, etc. used in cylinder manifold system shall comply with the distributing company's stipulations.

8.3.3.9 The individual component parts of manifolds, that is, piping, fittings, pigtails, etc., which are subject to cylinder pressure shall be capable of withstanding a test pressure without bursting of 2.5 N/mm² or one and half times the maximum pressure corresponding in the maximum assessed temperature of the cylinder, whichever is more.

8.3.3.10 Where cylinder installations are made up with service and reserve batteries of cylinders, suitable change-over devices or valves shall be incorporated in the manifold header to prevent undue escape of the gas when cylinders are changed.

8.3.3.11 It is recommended that joints in manifold headers which do not have to be taken in normal use should be welded or brazed using a material and which shall have melting point of at least 540°C.

8.3.3.12 All joints between manifold headers and cylinder connectors shall be readily accessible.

8.3.3.13 Pressure regulators and other devices used to control the gas shall comply with the distributing company's stipulations and accepted standards.

8.3.3.14 Care shall be taken that safety of a metal vent pipe connected to the safety valve outlets do not become choked with dust or other foreign matter.

8.3.3.15 If the regulator is fitted with a relief valve, care should be taken in positioning the regulator to avoid unnecessary hazards if the relief valve functions.

8.3.3.16 Pressure regulators and other control devices shall be adequately supported.

8.3.3.17 Instructions to Consumers: Necessary instructions dealing with the following aspects shall be supplied by the LPG supply company to each consumer in the form of a manual:

8.3.3.18 Operation of the whole system;

8.3.3.19 How to recognize and detect gas leakage;

8.3.3.20 Action to be taken in case of leakage;

8.3.3.21 Action to be taken in case of fire; and

8.3.3.22 Action to be taken in case of damage to, or failure of any part of the installation.

8.3.3.23 For detailed information regarding installation of LPG cylinders in commercial, educational and institutional premises, the LPG supply company shall be consulted.

8.4 Lpg Bulk Storage Installations

NFPA 58: Liquefied Petroleum Gas Code-2008 edition shall be followed along with approval of the gas supply company and the Authority having jurisdiction for LPG for bulk storage installations where storage tanks over 450 liters water capacity are used for domestic consumers' premises.

The maximum capacity an individual tank and group of tanks at domestic premises shall be as follows:

Maximum water capacity of an individual tank: 20,000 litre

Maximum water capacity of group of tanks: 80,000 litre

The LPG Bulk Storage Installations shall strictly adhere to the provisions laid down in NFPA 58: Liquefied Petroleum Gas Code-2008 edition or its equivalent for the followings:

Location and spacing of storage tanks

- (a) Bunding
- (b) Protection and Safety
- (c) Good house keeping
- (d) Warning Signs
- (e) Fire protection and fire extinguishers
- (f) Water supply
- (g) Sound engineering practice for design, layout and operation of the entire installations
- (h) Training of personnel on both operations and on action to be taken in an emergency
- (i) The gas supply company and the Authority having jurisdiction shall approve every item mentioned above and can add anything more that will improve safety of installation and people living around it.

8.5 Installation of Specific Appliances

8.5.1 General

8.5.1.1 Gas appliances, accessories, and equipment shall be "Approved". Listed and labeled appliances shall be installed in accordance with the manufacturer's installation instruction.

8.5.1.2 It shall be determined whether the appliance has been designed for use with the gas to which it will be connected. No attempt shall be made to convert the appliance from the gas specified on the rating plate for use with a different gas without consulting the gas supply company or the appliance manufacturer for complete instructions.

8.5.1.3 Safety shutoff devices of the complete shutoff type shall be installed on manually controlled water heaters and automatically controlled appliances, except domestic ranges.

8.5.1.4 Gas appliances shall not be installed in any location where flammable vapours are likely to be present or accumulate, unless the design, operation and installation are such as to eliminate the possibility of ignition of the flammable vapours.

8.5.1.5 Appliances shall be vented in accordance with the instructions of their manufacturers or the procedures of the gas supply company.

8.5.1.6 Gas appliances shall be firmly supported. They shall not exert undue strain on the connected piping and connections.

8.5.1.7 The installing agency shall conform to the appliance manufacturer's specific recommendations in completing an installation that will provide satisfactory performance and serviceability. The installing agency shall also leave the manufacturer's installation, operating and maintenance instructions in a readily accessible location on the premises for reference and guidance of the Authority, servicemen, and the consumer or operator.

8.5.1.8 All appliances shall be located with respect to building construction and other equipment so as to permit ready access to the appliance. Sufficient clearance shall be maintained to permit cleaning of heating surfaces, replacement of parts, adjustment, cleaning of burners and pilots and maintenance.

8.5.1.9 Connecting Appliances and Equipment: Appliances and equipment shall be connected to the building piping system by one of the following:

8.5.1.10 Rigid metallic pipe and fittings

8.5.1.11 Semi-rigid metallic tubing and metallic fittings. Aluminum-alloy tubing shall not be used in exterior locations.

8.5.1.12 Listed appliance connectors and only one connector shall be used per appliance

8.5.1.13 Semi-rigid tubing in lengths up to 2 m that are in the same room as the appliance

8.5.1.14 Listed gas hose connectors to be used as approved.

8.5.1.15 The connector or tubing shall be protected against physical and thermal damages.

8.5.1.16 Aluminum-alloy tubing and connectors shall be factory coated to protect against external corrosion where they are in contact with masonry, plaster or insulation or are subject to frequent wettings by such liquids as water (except rain water), detergents or sewage.

8.5.1.17 Any appliance connected to a piping system shall have an accessible approved manual shutoff valve with a displaceable valve member or a listed gas convenience outlet and shall be located within 2 m of the appliance it serves except as permitted by the Authority.

8.5.1.18 Appliance connectors may be connected to building piping by a listed quick disconnect device, and when installed indoors, a manual shutoff valve shall be installed upstream of the quick disconnect device.

8.5.1.19 Electrical connection between gas appliances and the building wiring shall conform to the approved electrical code.

8.5.1.20 No devices using or dependent upon electricity shall be used to control or ignite a gas supply if of such type that failure of the electricity would result in the escape of unburned gas, or in failure to reduce the supply of gas under conditions which would normally result in its reduction, unless other means are provided to prevent the creation of dangerous temperatures, pressures or the release of gas.

8.5.2 Cookers/Burners

8.5.2.1 Domestic cooking appliances shall be installed be listed and labeled as household type appliances for domestic use. These are installed in accordance with its listing and the manufacturer's instruction.

8.5.2.2 Listed cookers/burners when installed on combustible floors shall be set on their own bases or legs firmly and shall be installed in accordance with their listing and the manufacturer's instructions. In absence of clearance information the appliances shall be installed in consultation with the gas supply company. The clearances shall not interfere with the flow of combustion air, accessibility for operation and servicing.

8.5.2.3 Unlisted appliances when acceptable with the authority shall be installed with at least a 150 mm clearance at the back and sides to combustible material. Combustible floors under unlisted appliances shall be protected in an approved manner. Guidelines of the Authority shall be followed.

8.5.2.4 Appliances shall have a vertical clearance above the cooking top of not less than 750 mm to combustible material or metal cabinets.

8.5.2.5 Appliances shall be installed so that the top or oven racks are level.

8.5.3 Illuminating Appliances

8.5.3.1 Listed (labeled) illuminating appliances shall be installed in accordance with their listing and manufacturer's instructions.

8.5.3.2 Unlisted illuminating appliances may be used when acceptable to the Authority and they shall be installed in accordance with the guidelines of the Authority.

8.5.3.3 Illuminating appliances designed for wall or ceiling mounting shall be firmly attached to substantial structures in such a manner that they are not dependent on the gas piping for support.

8.5.3.4 Illuminating appliance designed for post mounting shall be firmly attached to a post which has proper strength and rigidity. Posts shall be rigidly erected.

8.5.4 Water Heaters

8.5.4.1 Water heater installation in bedrooms and bathrooms shall comply with one of the following:

8.5.4.2 Water heaters shall be installed in a closet equipped with a weather-stripped door with no openings and with a self-closing device. All combustion air shall be obtained from the outdoors through one or two permanent openings having cross-sectional area $1 \text{ in}^2/3000 \text{ Btu/hr}$ ($700 \text{ mm}^2/\text{kW}$). The minimum dimension of air opening shall not be less than 3 in (75 mm).

8.5.4.3 Water heater shall be of direct vent type

8.5.4.4 Listed (labeled) water heaters shall be installed in accordance with their listing and manufacturer's instructions. The clearances shall not be such as to interfere with combustion air, draft hood clearance and relief, and accessibility for servicing.

8.5.4.5 Unlisted water heaters shall be installed with a clearance of 300 mm on all sides and rear and they shall be installed with the approval of the authority following its guidelines.

8.5.4.6 Water heaters shall be connected in a manner to permit observation, inspection, maintenance and servicing.

8.5.4.7 Water heaters shall be fitted with limiting switches for pressure and temperature and also with temperature, pressure and vacuum relief devices as per a nationally recognized standards for such devices.

8.5.5 Stationery Gas Engine Generators

Stationary gas engine generators for generating power to meet emergency needs during power outage shall be installed in accordance with the manufacturer's installation instructions and shall meet the requirements of UL 2200-04 (Standard for Stationary Engine Generator Assemblies-2004) of USA or equivalent. The Equipment powered by internal combustion engines and turbines shall not be rigidly connected to the gas supply piping.

Installation of stationary gas engine generators in the building shall be approved by the Authority and the gas supply company; and all their regulations applicable shall be complied with for installation, testing, operation and maintenance.

8.6 Related Codes and Standards

The list includes those codes and standards that are acceptable as “good practice” and “accepted codes and standards” for complying with the requirements of this Code. The latest version of a code or standard shall be used. The list may be used by the authority as a guide to fulfill the requirements mentioned in this Code.

National Fuel Gas Code-2009 edition (NFPA 54/ANSI Z223-1).

Liquefied Petroleum Gas Code-2008 edition (NFPA 58).

International Fuel Gas Code-2009.

National Building Code of India-2005 (Part 9, Section 2, Gas supply).

ASME2004, Boiler and Pressure Vessel Code, Section; VIII; ‘Rules for the Construction of Unfired Pressure Vessels.

ASTM A53, Standard Specification for Pipe, Steel, Black and Hot-Dipped, Zinc Coated Welded and Seamless, 2007.

ASTM A106, Standard Specification for Seamless Carbon Steel Pipe for High-Temperature Services, 2006a

ASTM A539, Standard Specification for Electric Resistance-Welded Coiled Steel Tubing for Gas Fuel Oil Lines, 1999

ASTM B 43, Standard Specification for Seamless Red Brass Pipe, Standard sizes.

ASTM B88, Standard Specification for Seamless Copper Water Tube, 2003.

ASTM B210, Standard Specification for Aluminum and Aluminum-Alloy Drawn Seamless Tubes, 2004.

ASTM B210, Standard Specification for Aluminum and - Aluminum - Alloy Drawn Seamless Tubes, 2004.

ASTM B241, Standard Specification for Aluminum and Aluminum Alloy Seamless Pipe and Seamless Extruded Tube, 2002.

ASTM B280, Standard Specification for Seamless Copper Tube Air Conditioning and Refrigeration Field Service, 2008.

ASTM D2513, Standard Specification for Thermoplastic Gas Pressure Pipe, Tubing and Fittings, 2008a.

ANSI/ASME B36.10M, Welded and Seamless Wrought Steel Pipe, 2004.

ANSI LC 1/CSA 6.26, Fuel Gas Piping Systems Using Corrugated Stainless Steel Tubing (CSST), 2005.

ANSI Z21.1 Household Cooking Gas Appliances, 2005.

NFPA 37, Standard for the Installation and Use of Stationary Combustion Engines and Gas Turbines, 2006 edition.

NFPA 10, Standard for Portable Fire Extinguishers, 2007 edition.

Title 49, Code of Federal Regulations, Parts 191, 192 and 195, "Transportation of Hazardous Liquids by Pipeline".

UL 2200-04 Standard for Stationary Engine Generator Assemblies-2004.

8.7 List of Related Appendices

Appendix V	Work on the Gas Supply System
Appendix W	Documentation for Piping Installation

PART VIII
Appendix A
Maximum Demand and Diversity

Some information on the determination of the maximum demand for an electrical installation is provided in this appendix. It also includes some notes on the application of allowances for diversity. It is impossible however, to specify the appropriate allowances for diversity for every type of installation since determination of such allowances calls for special knowledge and experience. The figures shown in Table 8.A.1 are therefore, intended to act as guideline. The current demand of a final circuit is determined by summing the current demands of all points of utilization and equipment in the circuit. Typical values to be used for this summation are given in Table 8.A.2. For blocks of residential dwellings, large hotels, and industrial and large commercial premises, allowances are to be assigned by a competent Engineer.

The current demand of a circuit supplying a number of final circuits may be assessed by applying the allowances for diversity given in Table 8.A.2 to the total current demand of all the equipment supplied by that circuit. In the Table, the allowances are appraised either as percentages of the current demand or, where followed by the letters f.l., as percentages of the rated full load current of the current using equipment. After the design currents for all the circuits have been determined, enabling the conductor sizes to be chosen, it is necessary to check that the limitation on voltage drop is met.

Table 8.A.1: Allowances for Diversity

Purpose of final circuit fed from conductors or switchgear to which diversity applies	Type of Premises		
	Individual household installations, including dwellings of a block	Small shops, stores, offices and business premises	Small hotels, boarding houses, guest houses, etc.
1. Lighting	66% of total current demand	90% of total current demand	75% of total current demand
2. Cooking appliances	10 amperes + 30% f.l. of connected cooking appliances in excess of 10 amperes + 5 amperes if socket outlet is incorporated in unit.	100% f.l. of largest appliance + 80% f.l. of 2nd largest appliance + 60% f.l. of remaining appliances	100% f.l. of largest appliance + 80% f.l. of 2nd largest appliance + 60% f.l. of remaining appliances

Purpose of final circuit fed from conductors or switchgear to which diversity applies	Type of Premises		
	Individual household installations, including dwellings of a block	Small shops, stores, offices and business premises	Small hotels, boarding houses, guest houses, etc.
3. Motors (other than lift motors which are subject to special consideration)	————	100% f.l. of largest motor + 80% f.l. of 2nd largest motor + 60% f.l. of remaining motors	100% f.l. of largest motor + 50% f.l. of remaining motors.
4. Water heater (thermostatically controlled)		No diversity allowable	

Table 8.A.2: Current Demand to be Assumed for Points of Utilization and Current using Equipment

Point of Utilization or Current-using Equipment	Current Demand to be Assumed
15 A socket outlets	15 A with diversity applied
13 A socket outlets	13 A with diversity applied
5 A socket outlets	At least 0.5 A
Protected outlets other than the above mentioned socket outlets	Rated current
Lighting outlet	Current equivalent to the connected load, with a minimum of 100 W per lamp holder
House hold cooking appliance	The first 10 A of the rated current plus 30% of the remainder of the rated current plus 5 A if a socket outlet is incorporated in the control unit
All other stationary equipment / Appliances	Standard rated current or nominal current.

PART VIII
Appendix B
Useful Tables Relating to Conductor Sizes

Table 8.B.1: Number of Single-core Wire of Different Sizes for Various Sizes of Metal Conduits

Conductor Cross-sectional Area (mm ²)	Conduit Diameter					
	19 mm	25.4 mm	31.8 mm	38 mm	51 mm	63.5 mm
1.5	5	10	14	-	-	-
2.5	5	8	12	-	-	-
4.0	3	6	10	-	-	-
6.0	2	5	8	-	-	-
10.0	-	3	5	6	-	-
16.0	-	-	3	6	-	-
25.0	-	-	2	4	6	7
35.0	-	-	-	3	5	6
50.0	-	-	-	-	4	5

Table 8.B.2: Number of Single-core Wires of Different Sizes for Various Sizes of PVC Conduits

Conductor Cross-sectional Area (mm ²)	Conduit Diameter				
	19 mm	25 mm	32 mm	38 mm	51 mm
1.5	6	10	14	-	-
2.5	5	10	14	-	-
4.0	3	6	10	14	-
6.0	2	5	8	11	-
10.0	-	4	7	9	-
16.0	-	2	4	5	12
25.0	-	-	2	2	6
35.0	-	-	2	2	5
50.0	-	-	-	2	3

Table 8.B.3: Cross-sectional Area and Weight of Wire Gauges

Gauge System		Diameter	Cross-sectional Area	Weight of Copper	Weight of Aluminium
AWG	SWG	(mm)	(mm ²)	(kg/km)	(kg/km)
6/0	-	14.73	170.46	1515.4	460.4
5/0	-	13.11	134.92	1199.4	365.0
-	7/0	12.70	126.68	1126.2	342.1
-	6/0	11.79	109.09	969.8	294.6
4/0	-	11.68	107.22	953.2	289.4
-	5/0	10.97	94.56	840.7	255.4
3/0	-	10.41	85.16	757.2	229.6
-	4/0	10.16	81.70	720.7	219.6
-	3/0	9.449	70.12	623.4	189.4
2/0	-	9.271	67.51	600.1	182.1
-	2/0	8.839	61.36	545.5	165.7
0	-	8.255	53.52	475.8	144.4
-	0	8.230	53.19	472.9	143.6
-	1	7.620	45.60	405.4	123.1
1	-	7.341	42.22	376.2	114.5
-	2	7.010	38.60	343.1	104.2
2	-	6.553	33.94	299.8	90.80
-	3	6.401	32.18	286.1	86.89
-	4	5.893	27.27	242.5	73.63
3	-	5.817	26.57	236.2	72.01
4	-	5.182	21.09	187.5	57.11
-	6	4.877	18.68	166.1	50.44
5	-	4.623	16.78	149.2	45.25

Gauge System		Diameter	Cross-sectional Area	Weight of Copper	Weight of Aluminium
AWG	SWG	(mm)	(mm ²)	(kg/km)	(kg/km)
-	7	4.470	15.70	139.5	42.39
6	-	4.115	13.30	118.2	35.91
-	8	4.065	12.97	115.3	35.02
7	9	3.658	10.507	93.41	28.49
8	10	3.251	8.302	73.80	22.59
-	11	2.948	6.818	60.61	18.41
9	-	2.896	6.585	58.54	17.91
-	12	2.642	5.480	48.72	14.80
10	-	2.591	5.272	46.87	14.21
-	13	2.337	4.284	38.08	11.58
11	-	2.311	4.196	37.30	11.26
12	-	2.057	3.325	29.55	8.934
-	14	2.032	3.243	28.83	8.756
13	15	1.828	2.627	23.35	7.093
14	16	1.626	2.075	18.45	5.621
15	-	1.448	1.646	14.64	4.460
-	17	1.422	1.589	14.13	4.290
16	-	1.295	1.318	11.72	3.532
-	18	1.291	1.168	10.38	3.154
17	-	1.143	1.026	9.122	2.808
18	19	1.016	0.8107	7.207	2.223
19	20	0.9144	0.6567	5.838	1.773
20	21	0.8128	0.5189	4.613	1.401
21	-	0.7239	0.4156	3.695	1.111

Gauge System		Diameter	Cross-sectional Area	Weight of Copper	Weight of Aluminium
AWG	SWG	(mm)	(mm ²)	(kg/km)	(kg/km)
-	22	0.7112	0.3973	3.532	1.073
22	-	0.6428	0.3243	2.883	0.8756
-	23	0.6096	0.2919	2.595	0.7881
23	-	0.5733	0.2588	2.301	0.6990
-	24	0.5588	0.2453	2.181	0.6620
24	-	0.5105	0.2047	1.820	0.5527
-	25	0.5086	0.2021	1.797	0.5473

PART VIII
Appendix C
Completion Certificate Form (Electrical Works)

I/we certify that the installation detailed below has been installed by me/us and tested and that to the best of my/our knowledge and belief, it complies with the requirements of Bangladesh National Building Code and the Electricity Act of Bangladesh.

Electrical Installation at : _____

Voltage and system of supply : _____

**PARTICULARS OF
WORKS**

(a) Internal Electrical Installation

	<u>No.</u>	<u>Total load</u>	<u>Type or system of wiring</u>
(i) Light points			
(ii) Fan points			
(iii) Socket points			
2-pin 5 A			
3-pin 13 A Flat pin			
3-pin 15 A Round Pin			

(b) Others

	<u>Description</u>	<u>hp/kW</u>	<u>Type of starting</u>
(1) Motors			
(i)			
(ii)			
(iii)			
(2) Other Plants			

(c) If the work involves installations of overhead line and/or underground cable

- (1) (i) Type and description of overhead line
(ii) Total length and number of spans
(iii) Number of street lights and its description

- (2) (i) Total length and size of underground cable
- (ii) Number of joints
- End joint
- Tee joint
- Straight through joint

(d) Earthing

- (i) Description of earthing electrode
- (ii) Number of earth electrodes
- (iii) Type and short description of Brass Earthing Clamp
- Number of Brass Bolt Nuts provided in
- (iv) the Brass Earthing Clamp for the termination of Earth Lead Cables
- (v) Size of each of the main earth lead cables
- (vi) Number of main earth lead cables

TEST RESULTS

(a) Insulation Resistance values:

- (i) Insulation resistance of the whole system of conductors to earth _____ mega ohms
- (ii) Insulation resistance between the phase conductor and neutral
- Between phase R and neutral _____ mega ohms
- Between phase Y and neutral _____ mega ohms
- Between phase B and neutral _____ mega ohms
- (iii) Insulation resistance between the phase conductors in case of polyphase supply
- Between phase R and phase Y _____ mega ohms
- Between phase Y and phase B _____ mega ohms
- Between phase B and phase R _____ mega ohms

(b) Polarity test

Polarity of nonlinked single pole branch switches

(c) Earth continuity test

Maximum resistance between any point in the earth continuity conductor including metal conduits and main earthing lead _____ ohms

(d) Earth electrode resistance

Resistance of each earth electrode

(i) _____ ohms

(ii) _____ ohms

(iii) _____ ohms

(iv) _____ ohms

(e) Lightning protective system

Resistance of the whole of lightning protective system to earth before any bonding is effected with earth electrode and metal in/on the structure _____ ohms

Signature of Supervisor_____
Signature of Contractor

Name and Address _____

Name and Address _____

**PART VIII
Appendix D**

NC, NCB and Recommended Criteria for Sound Insulation

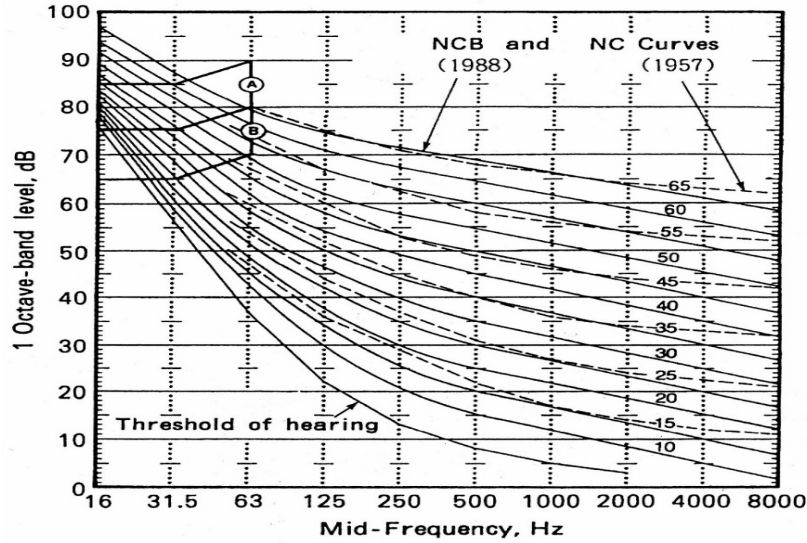


Figure 8.D.1 Noise Criteria (NC) and Balanced Noise Criteria (NCB) Curve
(Source: L. L. Beranek, 1957, 1988)

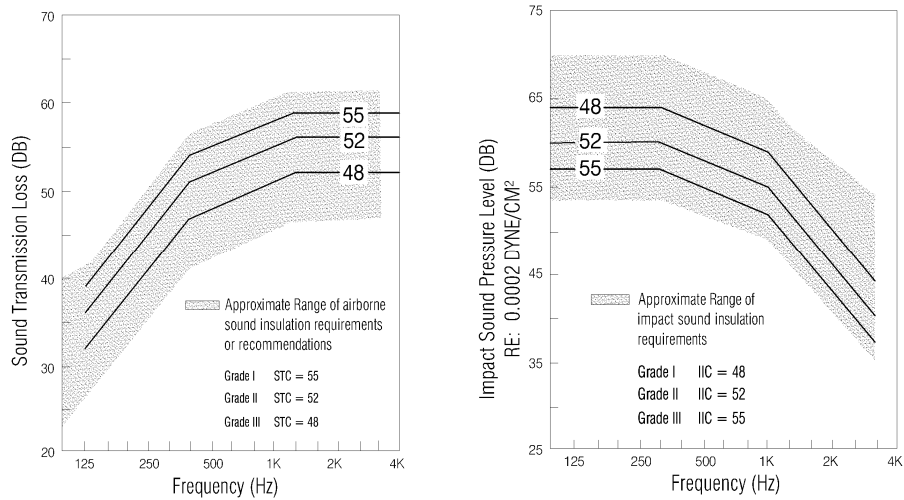


Figure 8.D.2 Recommended Criteria for Sound Insulation between Dwelling Units

(Source: Cavanaugh, W. J., Wilkes, J. A. 1999. *Architectural Acoustics Principals and Practice*, John Wiley & Sons, Inc, New York)

PART VIII
Appendix E

STC, Aural Field and Proportion of Space

Table 8.E.1: Typical STC Ratings for Building Elements

(Source: Stein, t al. 2006. *Mechanical and Electrical Equipment for Buildings*. John Willey & Sons, New Jersey)

Improvements in STC Ratings of Stud ^a Partitions ^b		STC Ratings of Masonry Walls	
Description	STC	Description	STC
Basic partition: single wood studs,	35	100 mm light weight hollow block	36
400 mm on centres, 13 mm gypsum board on both sides, air cavity		100 mm dense hollow block	38
Add to basic partition		150 mm lightweight hollow block	41
Double gypsum board, one side	+2	150 mm dense hollow block	43
Double gypsum board, both sides	+4	200 mm lightweight hollow block	46
Single thickness absorbent material in air cavity	+3	200 mm dense hollow block	48
Double-thickness insulation	+6	300 mm lightweight hollow block	51
Resilient channel supports for gypsum board	+5	300 mm dense hollow block	53
Staggered studs	+9	100 mm brick	41
Double studs	+13	150 mm brick	45
		200 mm brick	49
^a For application to metal stud partition, use adds as in note b, but begin with STC=40 for a 90mm basic partition.		300 mm brick	54
^b When using two improvements, add an additional +2; for three improvements, add +3.		150 solid concrete	47
^c The STC figures are conservative. Other sources list the same constructions with 1 to 5 points higher STC.		200 solid concrete	50
		250 solid concrete	53
		300 solid concrete	56
Typical STC Value for Doors		^a The STC figures are conservative. Other sources list the same constructions with 1 to 5 points higher STC.	
Door Construction	STC	^b All ratings of lightweight block assume sealing with paint. Note that this reduces absorption.	
Louvered door	15	Modifications	
Any door, 50 mm undercut	17	Add sand to core of hollow blocks	+3
38 mm hollow core door, no gasket	22	Add plaster to one side	+2
38 mm hollow core door, gaskets and drop closure	25	Add plaster to both side	+4
44 mm solid wood door, no gasket	30	Add furring strip, lath and plaster:	
44 mm solid wood door, gaskets and drop closure	35	One side	+6
Two hollow core doors, gasket all around, with sound lock	45	Two sides	+10
Two solid core doors, gasket all around, with sound lock	55	Add plaster via resilient mounting:	
Special commercial construction, with lead lining and full sealing	45-65	One side	+10
		Two sides	+15

Typical STC Ratings of Interior Partitions		Typical STC Value for Windows	
Type of Partition	STC	Window Construction	STC
Demountable partition	20-30	Operable wood sash, 3 mm glass unsealed	23
Drywall partition up to acoustical ceiling	30	Operable wood sash, 6 mm glass unsealed	25
Drywall partition extending 300 mm above acoustical ceiling tile system into ceiling plenum	35	Operable wood sash, 6 mm glass, with gasket	30
Drywall partition with cavity insulation, full height to the underside of slab above	40-45	Operable wood sash, laminated glass, unsealed	28
Two-layer drywall partition with insulation, erected full height to underside of slab above	50	Operable wood sash, double-glazed, 3mm panes, 10 mm air space, with gasket	29
		Fixed sash, double 3 mm panes, 75 mm air space, with gasket	44
		Fixed sash, double 3 mm panes, 100 mm air space, with gasket	48

Appendix E (Contd.)

Table 8.E.2: Recommended STC for Partitions for Specific Occupancies
(Source: Stein, B. et al., 2006. *Mechanical and Electrical Equipment for Buildings*.
John Wiley & Sons, New Jersey)

Type of Occupancy	Wall, Partition, or Panel Between		Sound Isolation Requirement: Background Level in Room Being Considered	
	Room Being Considered	and Adjacent Area	Quiet	Normal
Normal school buildings without extraordinary or unusual activities or requirements	Classrooms	Adjacent classrooms	STC 42	STC 40
		Corridor or public areas	STC 40	STC 38
		Kitchen and dining areas	STC 50	STC 47
		Shops	STC 50	STC 47
	Music practice rooms	Recreation areas	STC 45	STC 42
		Music rooms	STC 55	STC 50
		Mechanical equipment rooms	STC 50	STC 45
		Toilet areas	STC 45	STC 42
Executive areas, doctors suites; confidential privacy requirements	Office	Adjacent offices	STC 50	STC 45
		General office areas	STC 48	STC 45
		Corridor or lobby	STC 45	STC 42
		Washrooms and toilet areas	STC 50	STC 47
Normal office; normal privacy requirements; any occupancy using rooms for group meetings	Office	Adjacent offices	STC 40	STC 38
		Corridor, lobby, exterior	STC 40	STC 38
		Washrooms, kitchen, dining	STC 42	STC 40
	Conference rooms	Other conference rooms	STC 45	STC 42
		Adjacent offices	STC 45	STC 42
		Corridor or lobby	STC 42	STC 40
Large offices, drafting areas, banking floors, etc.	Large general office areas	Exterior of building	STC 40	STC 38
		Kitchen and dining areas	STC 45	STC 42
		Corridors, lobby, exterior	STC 38	STC 35
Motels and urban hotels, Hospitals and dormitories	Bedrooms	Data-processing area	STC 40	STC 38
		Kitchen and dining areas	STC 40	STC 38
		Adjacent bedrooms ^a	STC 52	STC 50
		Bathroom ^a	STC 50	STC 45
		Living rooms ^a	STC 45	STC 42
		Dining areas	STC 45	STC 42
		Corridor, lobby, or public spaces	STC 45	STC 42

^a Separate occupancy

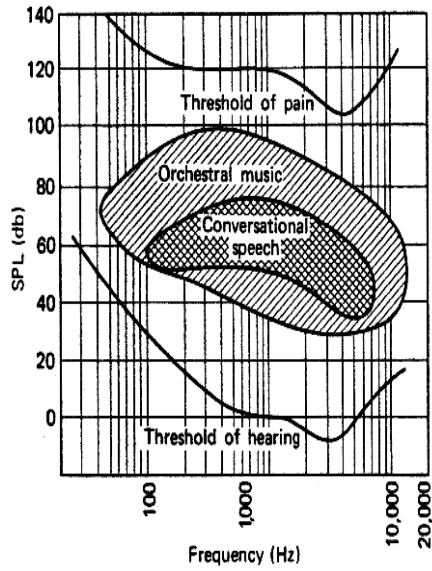


Figure 8.E.1 Speech and Music in Aural Field

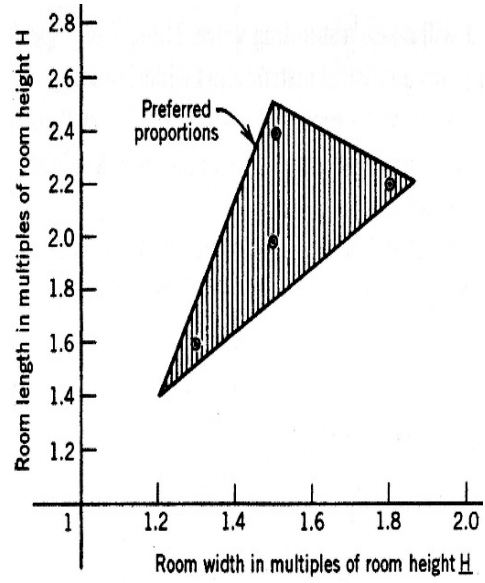


Figure 8.E.2 Recommended proportion of a space

PART VIII
Appendix F

Activity Flow Diagram: Planning, Design, Assessment and Construction in Building Acoustics

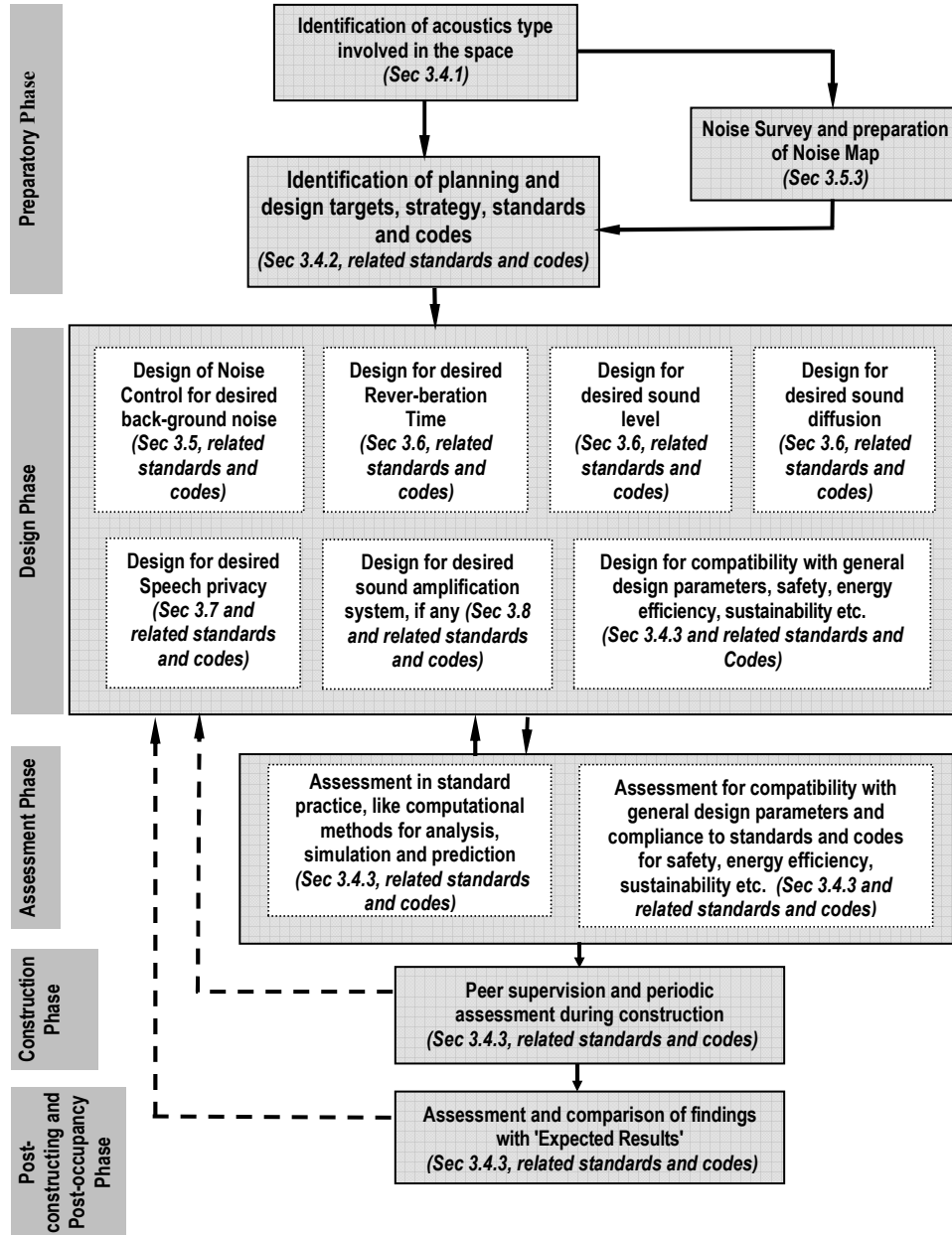


Figure 8.F.1 Activity Flow Diagram: Planning, Design, Assessment and Construction in Building Acoustics

**PART VIII
Appendix G**

Checklist for Acoustical Planning, Design and Post-occupancy Assessments

Form G: Checklist - Acoustical Planning, Design and Post-occupancy Assessments

Instructions:

- a) A separate form should be filled in for each space/room/building
- b) Fill in with text or put tick mark, as applicable
- c) After filling in and signing **Expected Result in Planning Design Phase**, submit the form to the project owner/ client
- d) A photocopy of the submitted Form (as mentioned above) shall be filled in and signed for **Post- occupancy Findings**

1. Name of the space/room/building for Acoustical Planning and Design:
2. Project name :
3. Location :
4. Owner/Client :
5. Lead Consultant :
6. Acoustical Consultant :
7. Type of acoustics involved in the space: Speech Music Multipurpose
8. Noise Survey on Site and Surroundings: Conducted Not Conducted
9. Noise Map: Prepared Not prepared
10. Design Parameters of the Space/Room/ Building:

Sl. No.	Design Parameters	Expected Results in Planning and Design Phase	Post-occupancy Findings
a)	Method Adopted:	<input type="checkbox"/> Assumptions <input type="checkbox"/> Only Manual Calculations <input type="checkbox"/> Computational Analysis, Simulation and Prediction	<input type="checkbox"/> Instrumental Survey <input type="checkbox"/> Opinion Survey <input type="checkbox"/> Both of above
b)	Ambient/Background level: i) L ₁₀ ii) L _{eq}	i) dBA ii) dBA	i) dBA ii) dBA
c)	Reverberation Time: i) At 1 kHz ii) Average of all applicable frequencies	i) s ii) s	i) s ii) s

Sl. No.	Design Parameters	Expected Results in Planning and Design Phase	Post-occupancy Findings
d)	Sound level in audience area (Average) dBA dBA
e)	Diffusion in audience area - Difference between max. and min. sound level: dBA dBA
f)	Signal-to-Noise Ratio (SNR) dBA dBA
g)	Intelligibility:		
	i) PSA	i) %	i) %
	ii) AI	ii) %	ii) %
	iii) STI	iii) %	iii) %
h)	Reverberance: Based on average absorption coefficient $\bar{\alpha}$: <0.2 = Live, 0.2 - 0.4 = Average, >0.4 = Dead	<input type="checkbox"/> Live <input type="checkbox"/> Average <input type="checkbox"/> Dead	<input type="checkbox"/> Live <input type="checkbox"/> Average <input type="checkbox"/> Dead
i)	Speech Privacy Rating:
J)	Overall quality (perceptual evaluation):	<input type="checkbox"/> Excellent <input type="checkbox"/> Good <input type="checkbox"/> Average <input type="checkbox"/> Poor	<input type="checkbox"/> Excellent <input type="checkbox"/> Good <input type="checkbox"/> Average <input type="checkbox"/> Poor
	Signature of the Acoustical Consultant: Date: Date:

PART VIII
Appendix H
Noise Levels and Subjective Evaluation

Table 8.H.1: Allowable upper limit of Outdoor Noise Levels

Source: *Noise Pollution (Control) Rules 2006*, the Government of the People's Republic of Bangladesh

Sl. No.	Category of Zones	Upper Limit of Noise Level in dBA $L_{Aeq,T}$	
		Day Time (06:00 AM - 09:00 PM)	Night Time (09:00 PM - 06:00 AM)
01	Quiet Zone	50	40
02	Residential Zone	55	45
03	Mixed Use Zone	60	50
04	Commercial Zone	70	60
05	Industrial Zone	75	70

Table 8.H.2: Typical Noise Levels Generated by Aircrafts

Source: *Noise Levels for U.S. Certified and Foreign Aircraft, Advisory Circular-AC No: 36-1H*, U.S. Department of Transportation, Federal Aviation Administration, 2012

Sl. No.	Aircraft Manufacturer and Model (Arranged in an alphabetical order)	Flyover Noise Levels with Take-off Thrust (EPN dBA) ^a
01	Airbus A300	103.1
02	Airbus A380	98.1
03	Boeing 707	108.3
04	Boeing 717	92.1
05	Boeing 727	105.8
06	Boeing 737	105.3
07	Boeing 747	107.8
08	Boeing 757	100.3
09	Boeing 767	103.0
10	Boeing 777	101.3
11	Boeing 787	99.6
12	Lockheed L-1011	103.3
13	McDonnell Douglas DC-08	102.7
14	McDonnell Douglas DC-10	106.6

^a Noise is measured at 1.2 m above the ground for aircrafts flying overhead at a height of 450 m from the ground with takeoff thrust. The highest noise level among different variations in the same model is listed.

Table 8.H.3: Subjective Evaluation and Pressure Levels of Familiar Sounds

Description of Sound	Subjective Evaluation	Pressure Level (dBA)
Near jet engine	Deafening	140
Threshold of pain		130
Threshold of feeling hard rock band		120
Accelerating motorcycle at a few metre away (Note: 15 m from motorcycle equals noise at about 600 m from a 4-engine aircraft)	Very loud	110
Full orchestra, loud passage		95
Noisy urban street, noisy factory	Loud	90
School cafeteria		80
Loud speech, 1 m distant; stenographic room	Moderate	70
Near freeway auto traffic		60
Conversational speech, 1 m distant; average office	Faint	50
Attentive theatre audience, total sound. Soft radio music in apartment.		40
Faint whisper, 1 m distant; average residence without stereo playing	Very faint	30
Average whisper		20
Rustle of one program, 8 m distant		15
Rustle of leaves in wind; human breathing		10
Threshold of audibility		0

PART VIII
Appendix I
PSA and Liveliness

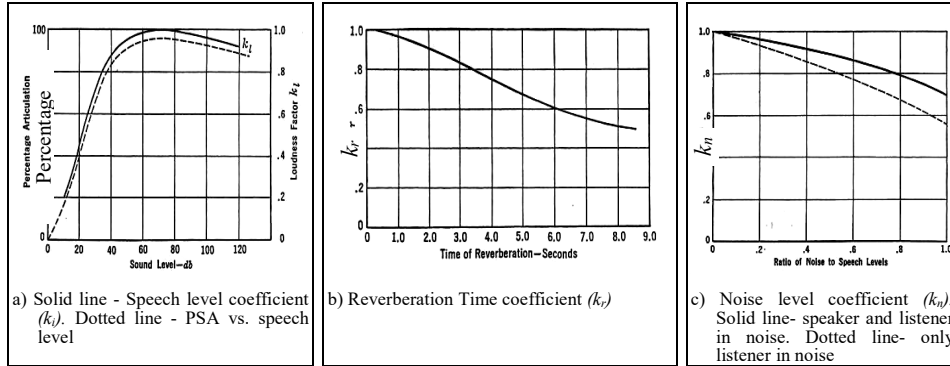


Figure 8.1.1 Coefficients for Percentage Syllable Articulation (PSA)
(Source: Knudsen, V. O. 1932. *Architectural Acoustics*, John Wiley & Sons Inc., New York)

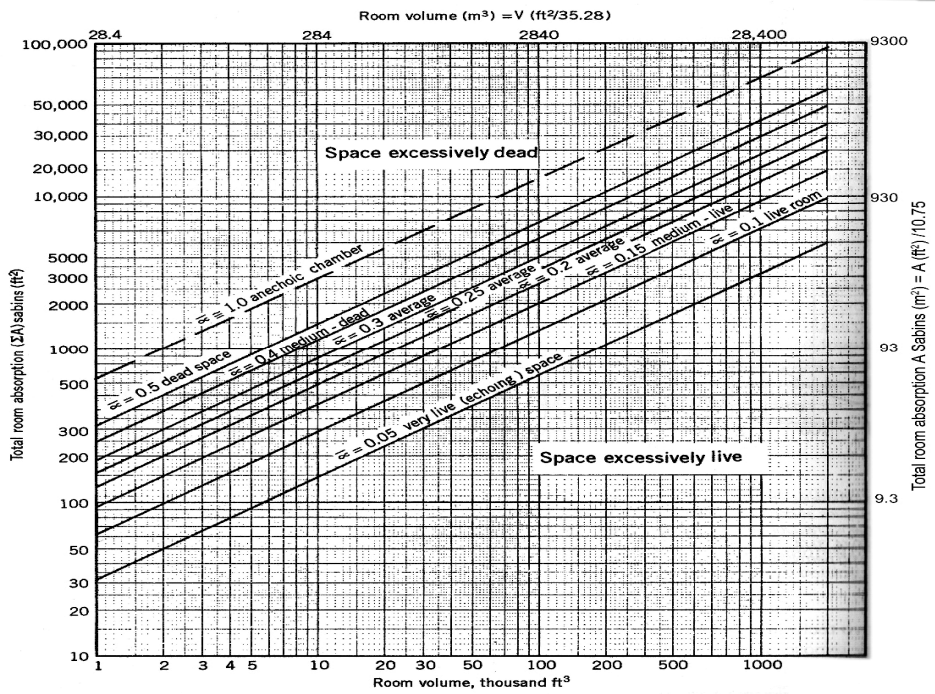


Figure 8.1.2 Liveliness of a Room as a Function of its Volume and Total Absorption

(Source: Stein, B. et al. 2006. *Mechanical and Electrical Equipment for Buildings*. John Wiley & Sons, New Jersey)

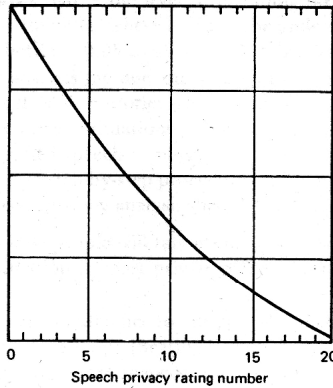
Note: The room proportions chosen as Length : Width : Height = $2H : 1.5H : H$; average of the three extreme points of the recommended room proportion triangle in Fig. 1.2. For these proportions, $S = 6.25 V^{2/3}$ and thus $A = S \alpha = 6.25 V^{2/3}$.

PART VIII
Appendix J
Speech Privacy Analysis Sheet

SPEECH PRIVACY: Analysis Sheet

Anticipated response to privacy situation

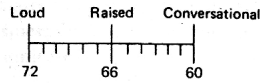
- Apparent satisfaction
- Mild dissatisfaction
- Moderate dissatisfaction
- Strong dissatisfaction
- Serious dissatisfaction



NOTE: Curve shows average response of people to intruding speech based on rating number figured below.

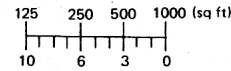
Speech rating

1. Speech effort – how people talk in source room

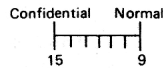


A. _____
B. _____
C. _____

2. Source room floor area (A_1) – approximates effect of source room absorption



3. Privacy allowance – degree of privacy desired

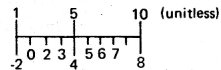


■ Speech rating total

Isolation rating

4. Sound transmission class (STC) – accounts for transmission loss of common barrier

5. Noise reduction factor (A_2/S) – approximates effect of receiving room sound absorption and common barrier size



6. Adjacent room background noise level (dBA) – masking sound available

■ Isolation rating total

Speech privacy rating number

Find speech privacy rating number by subtracting isolation rating total from speech rating total. Then use graph at top of sheet to predict degree of satisfaction.

=====

Figure 8.J.1 Speech Privacy Analysis Sheet

(Source: Egan, M. D. 1972. *Concepts in Architectural Acoustics*, McGraw-Hill Book Company, New York)

PART VIII
Appendix K
Sound Absorption Coefficients

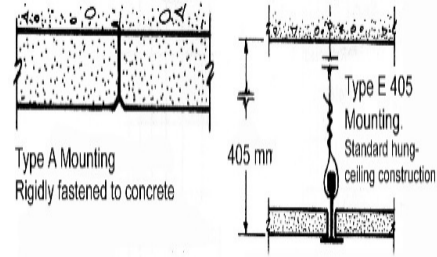
Table 8.K.1: Sound Absorption Coefficients ^a

Source: Stein, B. et al., 2006. *Mechanical and Electrical Equipment for Buildings*. John Wiley & Sons, New Jersey

	Absorption Coefficients (α)						NRC ^c
	125 Hz	250 Hz	500 Hz	1000 Hz	2000 Hz	4000 Hz	
General Building Materials and Furnishings ^b							
Brick, unglazed	0.03	0.03	0.03	0.04	0.05	0.07	0.005
Brick, unglazed, painted	0.01	0.01	0.02	0.02	0.02	0.03	0.00
Carpet, heavy, on concrete	0.02	0.06	0.14	0.37	0.60	0.65	0.29
Carpet, heavy, on 1.36 kg/m ² hair felt or foam rubber	0.08	0.24	0.57	0.69	0.71	0.73	0.55
Concrete block, coarse	0.36	0.44	0.31	0.29	0.39	0.25	0.35
Concrete block, painted	0.10	0.05	0.06	0.07	0.09	0.08	0.05
Fabrics							
Light velour, 0.34 kg/m ² , hung straight, in contact with wall	0.03	0.04	0.015	0.17	0.24	0.35	0.15
Medium velour, 0.47 kg/m ² , draped to half area	0.07	0.31	0.49	0.75	0.70	0.60	0.55
Heavy velour, 0.61 kg/m ² , draped to half area	0.14	0.35	0.55	0.72	0.70	0.65	0.60
Floors							
Concrete or terrazzo	0.01	0.01	0.015	0.02	0.02	0.02	0.00
Linoleum, asphalt, rubber, or cork tile on concrete	0.02	0.03	0.03	0.03	0.03	0.02	0.05
Wood	0.15	0.11	0.10	0.07	0.06	0.07	0.10
Glass							
Large panes of heavy plate glass	0.18	0.06	0.04	0.03	0.02	0.02	0.05
Ordinary window glass	0.35	0.25	0.18	0.12	0.07	0.04	0.15
Gypsum board, 13 mm nailed to 50x100 mm stud 400 mm c/c	0.10	0.08	0.05	0.03	0.03	0.03	0.05
Marble or glazed tile	0.01	0.01	0.01	0.01	0.02	0.02	0.00
Openings							
Stage, depending on furnishings	0.25-0.75						
Deep balcony, upholstered seats	0.50-1.00						
Grillese ventilating	0.15-0.50						

General Building Materials and Furnishings ^b	Absorption Coefficients (α)							
	125 Hz	250 Hz	500 Hz	1000 Hz	2000 Hz	4000 Hz	NRC ^c	
Plaster, gypsum or lime, smooth finish on tile or brick	0.013	0.015	0.02	0.03	0.04	0.05	0.05	
Plaster, gypsum or lime, on lath	0.14	0.10	0.06	0.05	0.04	0.03	0.05	
Plywood panelling, 9 mm thick	0.28	0.22	0.17	0.09	0.10	0.11	0.15	
Rough wood, as tongue-and-groove cedar	0.24	0.19	0.14	0.08	0.13	0.10	0.14	
Slightly vibrating surface (e.g., hollow core door)	0.02	0.02	0.03	0.03	0.04	0.05	0.03	
Readily vibrating surface (e.g., thin wood panelling on 400 mm studs)	0.10	0.07	0.05	0.04	0.04	0.05	0.05	
Water surface, as in swimming pool	0.008	0.008	0.013	0.015	0.020	0.025	0.00	
Absorption of Seats and Audience^d	125 Hz	250 Hz	500 Hz	1000 Hz	2000 Hz	4000 Hz	NRC^c	
Audience, in upholstered seats, per 0.093 m ² of floor area	0.60	0.74	0.88	0.96	0.93	0.85	-	
Unoccupied cloth-upholstered seats, per 0.093 m ² of floor area	0.49	0.66	0.80	0.88	0.82	0.70	-	
Wooden pews, occupied, per 0.093 m ² of floor area	0.57	0.61	0.75	0.86	0.91	0.86	-	
Students in tablet-arm chairs, per 0.093 m ² of floor area	0.30	0.42	0.50	0.85	0.85	0.84	-	
Acoustic Absorptive Materials	Mtg^e	125 Hz	250 Hz	500 Hz	1000 Hz	2000 Hz	4000 Hz	NRC^c
High-performance vinyl-faced fibreglass								
Ceiling panels								
25 mm thick	E405	0.73	0.88	0.71	0.98	0.96	0.77	0.90
38 mm thick	E405	0.79	0.98	0.83	1.03	0.98	0.80	0.95
Painted nubby glass cloth panels								
6 mm thick	E405	0.81	0.94	0.65	0.87	1.00	0.96	0.85
25 mm thick	E405	0.78	0.92	0.79	1.00	1.03	1.10	0.95
Random fissured 19 mm-thick panels	E405	0.52	0.58	0.60	0.80	0.92	0.80	0.70
Perforated metal panel with infill 1 in. thick	E405	0.70	0.86	0.74	0.88	0.95	0.86	0.85
Typical averages, mineral fibre tiles and panels								
19 mm fissured	E405	0.47	0.50	0.52	0.76	0.86	0.81	0.65
19 mm textured	E405	0.49	0.55	0.53	0.80	0.94	0.83	0.70
16 mm fissured	E405	0.28	0.33	0.66	0.73	0.74	0.75	0.60
16 mm textured	E405	0.29	0.35	0.66	0.63	0.44	0.34	0.50
16 mm perforated	E405	0.27	0.29	0.55	0.78	0.69	0.53	0.60
75 mm in thick x 400 mm square on 600 mm centres	A	0.40	0.61	1.92	2.54	2.62	2.60	

- a This table primarily useful for preliminary calculations. Complete tables of coefficients may be found in books on architectural acoustics.
- b Selected data courtesy of Owens-Corning Fibreglass.
- c NRC: the arithmetic average of the α values at 250, 500, 1000, and 2000 Hz.
- d If audience is randomly spaced, use an average of 0.47 m² sabins per person.
- e See figure at right for mounting methods Type A and Type E 405.



PART VIII
Appendix L
Particulars of Lifts, Escalators and Moving Walks

Format for Particulars of Lifts, Escalators and Moving Walks

LIFT

- a) Use (Tick as appropriate): Passenger/Goods/Services/Hospital
- b) Number of lifts required: _____
- c) Capacity per lift: Number of passengers _____ Kg _____
- d) Rated Speed: _____ m/s
- e) Travel height: _____ m
- f) Size and type of car doors: _____
- g) Number of car doors: _____
- h) Number of stops: _____
- i) Size and type of landing doors: _____
- j) Number of stops: _____
- k) Type of Drive system: _____
- l) Method of control(s): _____
- m) Size(s) and location(s) of lift well(s): _____
- n) Available Over Head Height: _____
- o) Pit Depth : _____
- p) Location and size of machine room: _____
- q) Position of counter weight: _____
- r) Size of car platform: _____
- s) Construction, design and finish of car bodywork: _____
- t) Construction, design and finish of car platform: _____
- u) Particulars of ventilation of the car: _____
- v) Particulars of control buttons in car: _____
- w) Particulars of position indicators in car: _____
- x) Particulars of call buttons in landing: _____

- y) Particulars of car position indicators in landings: _____
- z) Electric supply:
 Power: _____ volts, ac/dc, _____ phase, _____ Hz/wire system _____
 Lighting: _____ volts, ac/dc, _____ Hz/sec,
- aa) Layout of Lifts: _____
- bb) Details of Access to machine room: _____
- cc) Buffer type: _____
- dd) Additional requirements, if any: _____

ESCALATOR

- a) Number of escalators required: _____
- b) Capacity of each escalator (No. of people/hr): _____
- c) Rated speed _____ m/s
- d) Travel height _____ m, Travel length _____ m
- e) Width of escalator _____ m
- f) Construction, design and finish of balustrade: _____
- g) Details of steps: _____
- h) Materials of landing plate: _____
- i) Electric supply:
 Power: _____ volts, ac/dc, _____
 Phase _____ Hz/wire system _____
- j) Additional requirements, if any: _____

MOVING WALK

- a) Number of moving walks required : _____
- b) Capacity of each moving walk (No. of people/hr) : _____
- c) Rated Speed _____ m/s
- d) Inclination _____ degrees
- e) Width of moving walk _____ m
- f) Construction, design and finish of balustrade: _____
- g) Material of landing plate: _____
- h) Electric supply:
 Power: _____ volts, ac/dc, _____
 Phase _____ Hz/wire system _____
- i) Additional requirements, if any: _____

PART VIII
Appendix M
Application Format for Permit to Construct Water Supply and
Distribution System

Application for Permit to Construct Water Supply and Distribution System

1. Name of the Applicant (Owner of holdings): _____
 Father's Name: _____
 Mother's Name: _____
2. Address & Location of Plot/Holdings:
 Ward No. _____ Road No. _____ House No. _____
 Boundary Description _____
3. (a) Description of Holdings, Buildings and Premises (Type of Building/Structure) _____
 (b) Occupancy Classification _____
 (c) No. of Floors, Room Nos. _____
4. (a) Total Population _____
 (b) Type of Connection (Residential _____ / Commercial _____ / Industrial _____)
 (c) Total Water Requirement (Calculation Sheet should be attached) _____ and
 (d) Size of Water Connection (diameter of pipe) required _____
5. Under-ground water Reservoir Capacity (where required) _____
6. Certificate of Bill Payers _____
7. This application is accompanied by all required plans, drawing of buildings, design calculations of water requirement in accordance with Section 5.3.2 and 5.3.3 of Bangladesh National Building Code.

Signature of the licensed plumber

Signature of the Owner or his/
her designated person/agent

Name and Address _____

Name and Address _____

**PART VIII
Appendix N**

Format of Completion Certificate (Water Supply Works)

Completion Certificate (Water Supply Works)

Certified that I/we have completed the plumbing work of water connection No _____
for the premises as detailed below. This may be inspected and connection given.

Ward No. _____ Road No. _____ House No. _____

Existing water connection No. (if any) _____

Owned by _____

Owner's address : _____

Applicant's name : _____

son of _____

Address : _____

Situated _____ Size of
main _____ on _____ Street _____

Where main is _____ Size of service pipe _____

Size of ferrule _____ No. of taps _____ No. of closets _____

Capacity of Underground Reservoir (where required) _____

No. of other fittings and appliances _____

Road cutting and repairing fee _____

Paid Tk. _____ (Receipt No. _____ dated _____ (receipt enclosed)

Dated _____ Signature of the licensed plumber _____

Name and address of the licensed plumber _____

The Authority's Report/ Certificate :

Certified that the communication and distribution pipes and all water fittings have been laid,
applied and executed in accordance with Chapter 5 of Part 8 of the Bangladesh National Building
Code, and satisfactory arrangements have been made for draining off waste water.

The water supply connection will be made on _____

Date _____

Water Supply Authority _____

PART VIII
Appendix O

Sizing of Cold Water Supply and Distribution Piping

The water distribution within the building may be an up-feed or down-feed system. The design principles are the same for both the systems. The principal difference in the calculation procedure is that in the up-feed system the difference in elevation between the fixtures and the water supply main exerts the pressure that supplies water into the fixtures, but in the down-feed system the difference in elevation between the fixtures and the roof storage tank provides the pressure to overcome the pipe friction. The following are the recommended pipe sizing procedures:

- O.1 The sketch of the main lines, risers and branches serving different fixtures will have to be drawn.
- O.2 Determine the number and types of fixture that will be required on the basis of the Table 8.6.1 in Chapter 6.
- O.3 The demand weight of different fixture units may be computed in terms of water supply fixture unit (wsfu) in accordance with Table 8.O.1.
- O.4 The peak demand load (or maximum probable flow) in liter per minute may be estimated with the data obtained in Sec O.3 using Figure 8.O.1 or on the basis of the number of occupants according to their occupancy classification specified in Table 8.5.1.
- O.5 The equivalent length of the main lines, risers and branches will be determined. The equivalent length of different fittings may be estimated on the basis of the data presented in the Tables 8.O.2(a), 8.O.2(b) and 8.O.2(c) or from manufacturer's specification. The total equivalent length is the sum of the equivalent lengths of all pipes and fittings.
- O.6 The pressure loss through water meter may be determined on the basis of their operating characteristics as shown in Figure 8.O.6 (Disk type water meter). The data for other types of water meter may be obtained from the manufacturer.
- O.7 The minimum pressure required at different fixtures to produce adequate flow may be estimated on the basis of the type of fixtures or minimum size of supply pipe in accordance with Table 8.5.6.
- O.8 The average pressure drop in kPa per meter of equivalent pipe length may be computed as follows:

$$F_p = (P \pm 9.807 H - f) / L \quad 8.O.1)$$

Where, F_p = Average available pressure loss (kPa) per meter of equivalent length of pipe

P = Pressure (kPa) in the water main or zero for overhead gravity storage tank.

H = Height (m) of the highest fixture above the water main or difference (m) in elevation between storage tank and the fixture under consideration.

f = Pressure loss (kPa) through water meter or such other fittings plus pressure (kPa) required to produce adequate flow through the most remote fixture in upfeed system or the fixture under consideration in down-feed system.

L = Equivalent pipe length (m)

* + sign is for down-feed system and - sign is for up-feed system

O.9 The pipe size may also be estimated from Figures 8.0.5 to 8.0.10 for different types of piping materials on the basis of the expected rate of flow determined in Sec 0.4 and the average pressure available for friction loss (F_p) in Sec O.8.







O.10 Alternative simple procedure of pipe size computation has also been explained in the Sec 5.10.3.

Table 8.O.1: Water Supply Fixture Unit (wsfu) Values for Various Plumbing Fixtures

Fixture or group	Supply Control	wsfu		Total
		Cold	Hot	
Bath group	Flush tank	4.5	3	6
Bath group	Flush valve	6	3	8
Bathtub	Faucet	1.5	1.5	2
Bidet	Faucet	1.5	1.5	2
Combination	Faucet	2	2	3
Kitchen sink	Faucet	1.5	1.5	2
Laundry tray	Faucet	2	2	3
Laundry	Faucet	1.5	1.5	2
Pedestal urinal	Flush valve	10	-	10
Restaurant sink	Faucet	3	3	4
Service sink	Faucet	1.5	1.5	2
Shower head	Mixing Valve	3	3	4
Stall or wall urinal	Flush tank	3	-	3
Stall or wall urinal	Flush valve	5	-	5
Water closet	Flush tank	5	-	5
Water closet	Flush valve	10	-	10

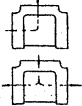
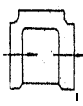


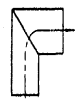
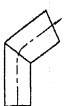


* Fixture with both cold and hot water supplies, the weight for maximum separate demands may be considered 75% of total wsfu.

Table 8.O.2(a): Fitting Losses In Equivalent Metre of Pipe - Screwed, Welded, Flanged, Flared and Brazed Connections

Nominal Pipe or Tube Size (mm)	Smooth Bend Elbows					
	90° Std*	90° Long Rad.**	90° Street*	45° Std*	45° Street*	180° Std*
						
10	0.43	0.27	0.70	0.21	0.34	0.70
13	0.49	0.31	0.76	0.24	0.40	0.76
19	0.61	0.43	0.98	0.27	0.49	0.98
25	0.79	0.52	1.25	0.40	0.64	1.25
32	1.01	0.70	1.71	0.52	0.92	1.71
38	1.22	0.79	1.92	0.64	1.04	1.92
50	1.53	1.01	2.50	0.79	1.37	2.50
63	1.83	1.25	3.05	0.98	1.59	3.05
75	2.29	1.53	3.66	1.22	1.95	3.66
88	2.75	1.80	4.58	1.43	2.23	4.58
100	3.05	2.04	5.19	1.59	2.59	5.19
125	3.97	2.50	6.41	1.98	3.36	6.41
150	4.88	3.05	7.63	2.41	3.97	7.63
200	6.10	3.97	-	3.05	-	10.07
250	7.63	4.88	-	3.97	-	12.81
300	9.15	5.80	-	4.88	-	15.25
350	10.37	7.02	-	5.49	-	16.78
400	11.59	7.93	-	6.10	-	18.91
450	12.81	8.85	-	7.02	-	21.35
500	15.25	10.07	-	7.93	-	24.71
600	18.30	12.20	-	9.15	-	28.67

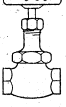
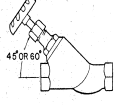
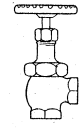
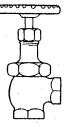
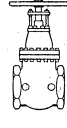
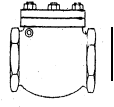

* = R/D approximately equal to 1, ** = R/D approximately equal to 1.5

Table 8.O.2(b): Fitting Losses in Equivalent Metre of Pipe - Screwed, Welded, Flanged, Flared and Brazed Connections

Nominal Pipe or Tube Size (mm)	Smooth Bend Tees				Metre Elbows			
	Flow Thru Branch	Straight-Thru Flow			90° Ell	60° Ell	45° Ell	30° Ell
		No Reduction	Reduced ¼	Reduced ½				
								
10	0.82	0.27	0.37	0.43	0.82	0.34	0.18	0.09
13	0.92	0.31	0.43	0.49	0.92	0.40	0.21	0.12
19	1.22	0.43	0.58	0.61	1.22	0.49	0.27	0.15
25	1.53	0.52	0.70	0.79	1.53	0.64	0.31	0.21
32	2.14	0.70	0.95	1.01	2.14	0.92	0.46	0.27
38	2.44	0.79	1.13	1.22	2.44	1.04	0.55	0.34
50	3.05	1.01	1.43	1.53	3.05	1.37	0.70	0.40
63	3.66	1.25	1.71	1.83	3.66	1.59	0.85	0.52
75	4.58	1.53	2.14	2.29	4.58	1.95	0.98	0.61
88	5.49	1.80	2.44	2.75	5.49	2.23	1.22	0.73
100	6.41	2.04	2.75	3.05	6.41	2.59	1.37	0.82
125	7.63	2.50	3.66	3.97	7.63	3.36	1.83	0.98
150	9.15	3.05	4.27	4.88	9.15	3.97	2.14	1.22
200	12.20	3.97	5.49	6.10	12.20	5.19	2.75	1.56
250	15.25	4.88	7.02	7.63	15.25	6.41	3.66	2.20
300	18.30	5.80	7.93	9.15	18.30	7.63	3.97	2.44
350	20.74	7.02	9.15	10.37	20.74	8.85	4.58	2.75
400	23.79	7.93	10.68	11.59	23.79	9.46	5.19	3.05
450	25.93	8.85	12.20	12.81	25.93	11.29	5.80	3.36
500	30.50	10.07	13.42	15.25	30.50	12.51	6.71	3.97
600	35.08	12.20	15.25	18.30	35.08	14.95	7.63	4.88

* = R/D approximately equal to 1, ** = R/D approximately equal to 1.5

Table 8.O.2(c): Valve Losses in Equivalent Metre of Pipe - Screwed, Welded, Flanged and Flared Connections

Nominal Pipe or Tube Size (mm)	Globe	60° – Y	45° – Y	Angle*	Gate	Swing Check**	Lift Check
							
10	5.19	2.44	1.83	1.83	0.18	1.53	Globe Lift and Vertical Lift: Same as Globe Valve**
13	5.49	2.75	2.14	2.14	0.21	1.83	
19	6.71	3.36	2.75	2.75	0.27	2.44	
25	8.85	4.58	3.66	3.66	0.31	3.05	
32	11.59	6.10	4.58	4.58	0.46	4.27	
38	13.12	7.32	5.49	5.49	0.55	4.88	
50	16.78	9.15	7.32	7.32	0.70	6.10	
63	21.05	10.68	8.85	8.85	0.85	7.63	
75	25.62	13.12	10.68	10.68	0.98	9.15	
88	30.50	15.25	12.51	12.51	1.22	10.68	
100	36.60	17.69	14.34	14.34	1.37	12.20	Angle Lift: Same as Angle Valve
125	42.70	21.66	17.69	17.69	1.83	15.25	
150	51.85	26.84	21.35	21.35	2.14	18.30	
200	67.10	35.08	25.93	25.93	2.75	24.40	
250	85.40	44.23	32.03	32.03	3.66	30.50	
300	97.60	50.33	39.65	39.65	3.97	36.60	
350	109.8	56.43	41.18	41.18	4.58	41.18	
400	125.05	64.05	54.90	54.90	5.19	45.75	
450	140.3	73.20	61.00	61.00	5.80	50.33	
500	158.6	83.88	71.68	71.68	6.71	61.00	
600	186.05	97.60	80.83	80.83	7.63	73.20	
* These losses do not apply to valves with needle point type seat, ** Losses also apply to the in-line, ball type check valve.							

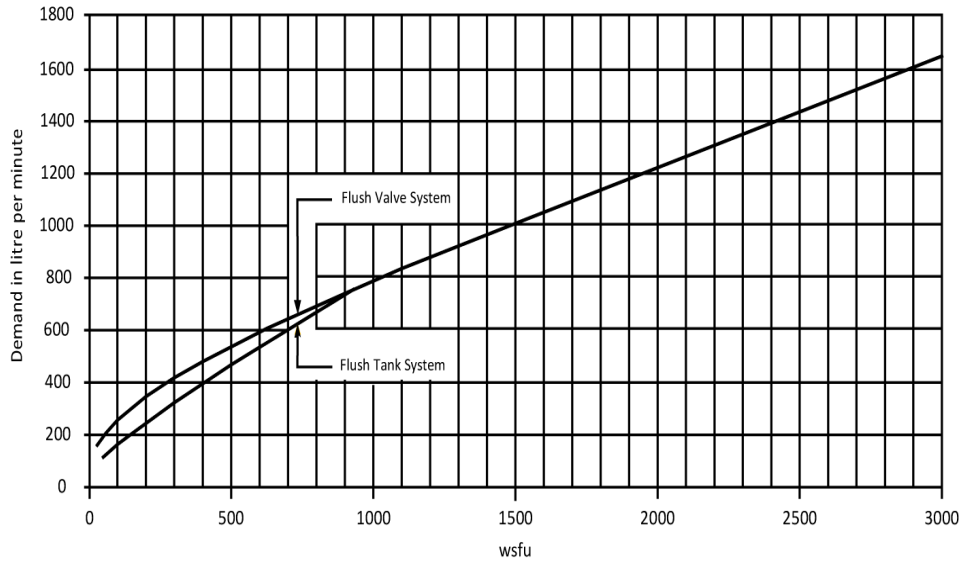


Figure 8.O.1 Water supply demand for various load in water supply fixture units (Wsfu)

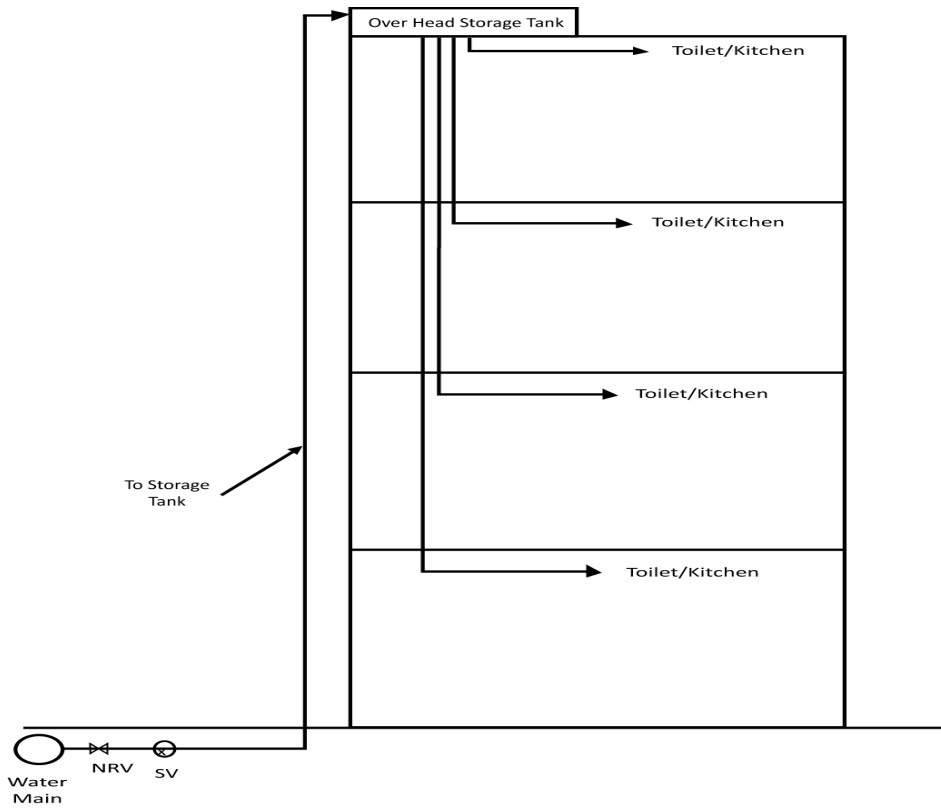


Figure 8.O.2(a) Direct connection of roof storage tank with public water main

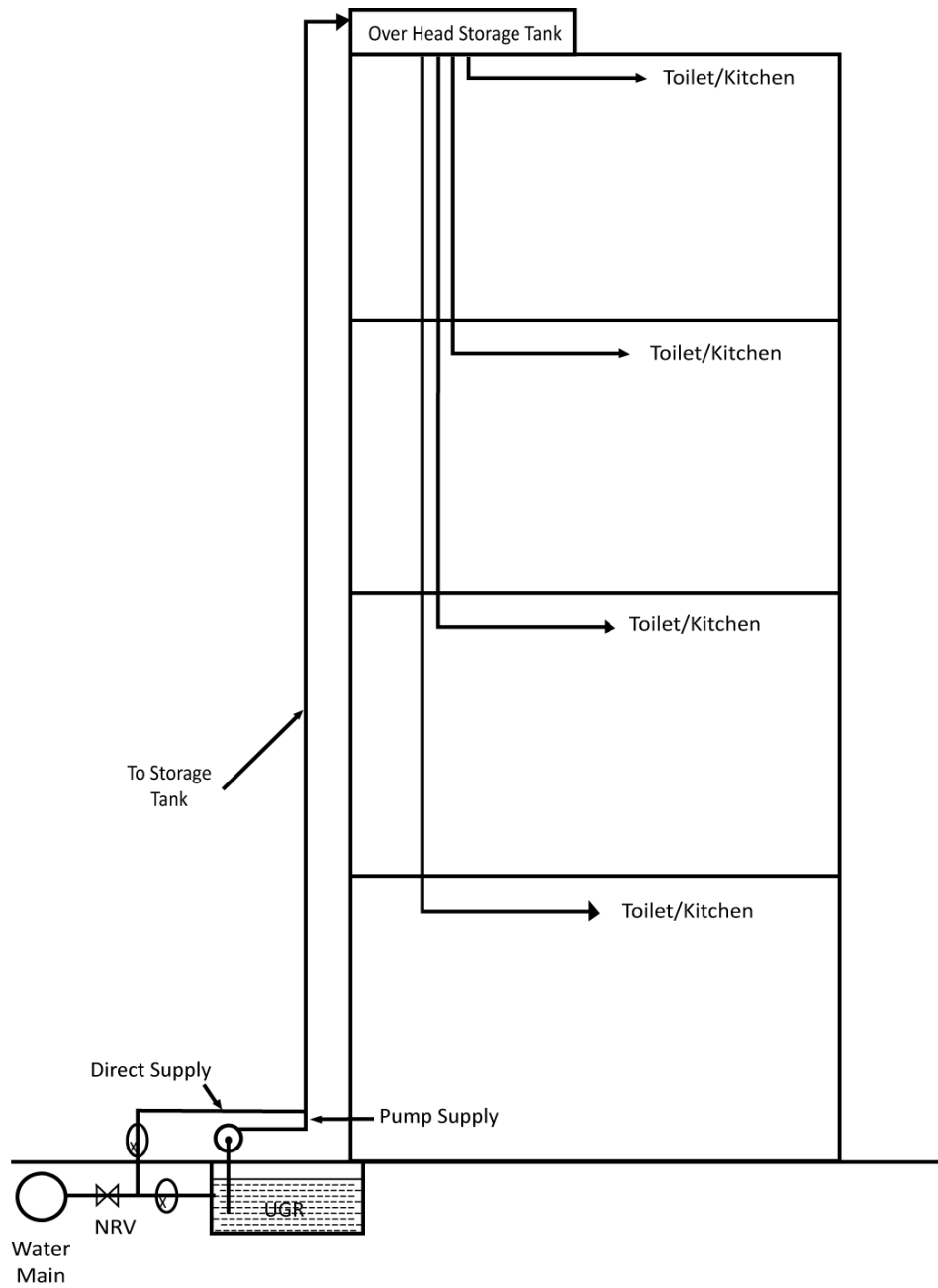


Figure 8.O.2(b) System incorporating balancing roof tank and direct water main connection

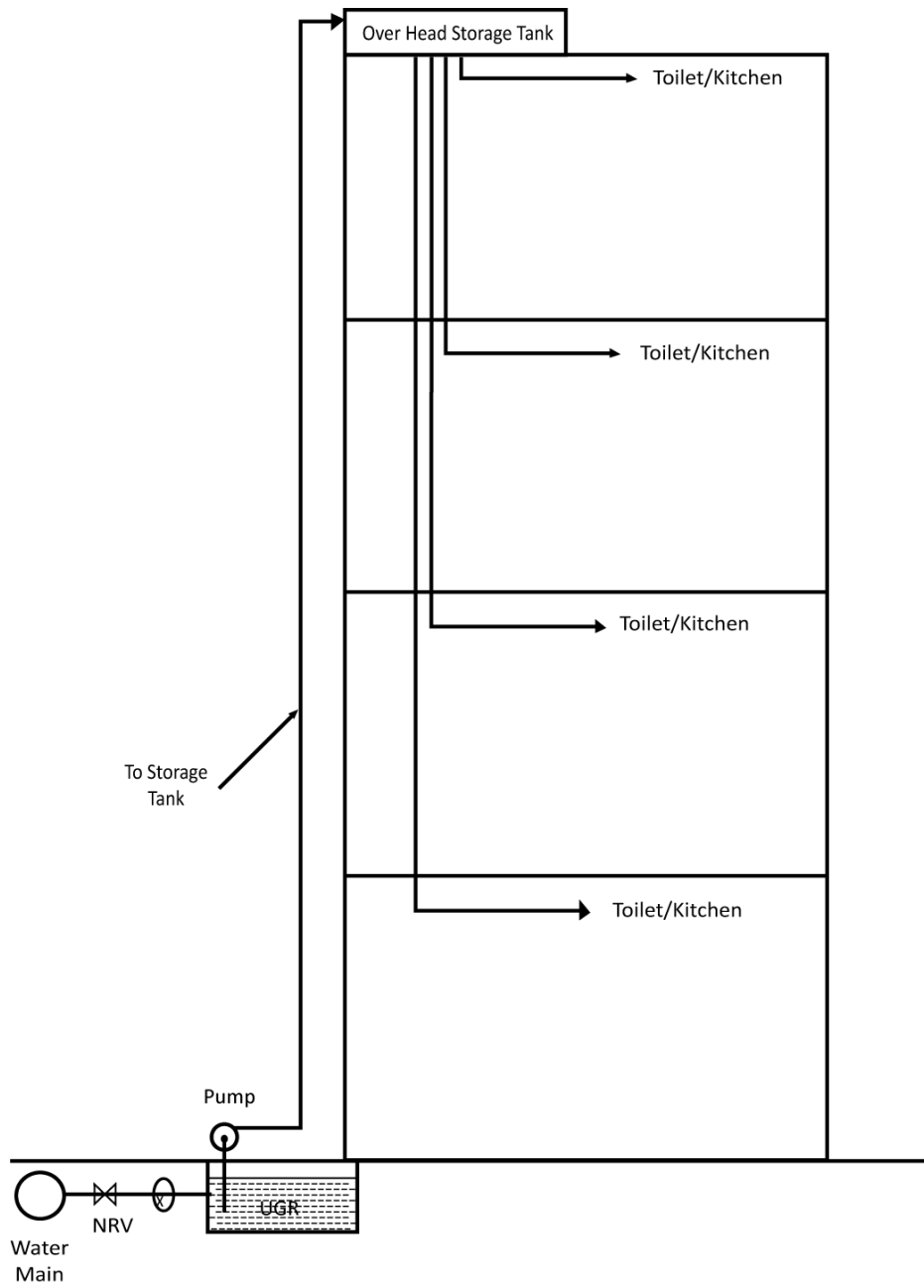


Figure 8.O.2(c) System incorporating underground tank

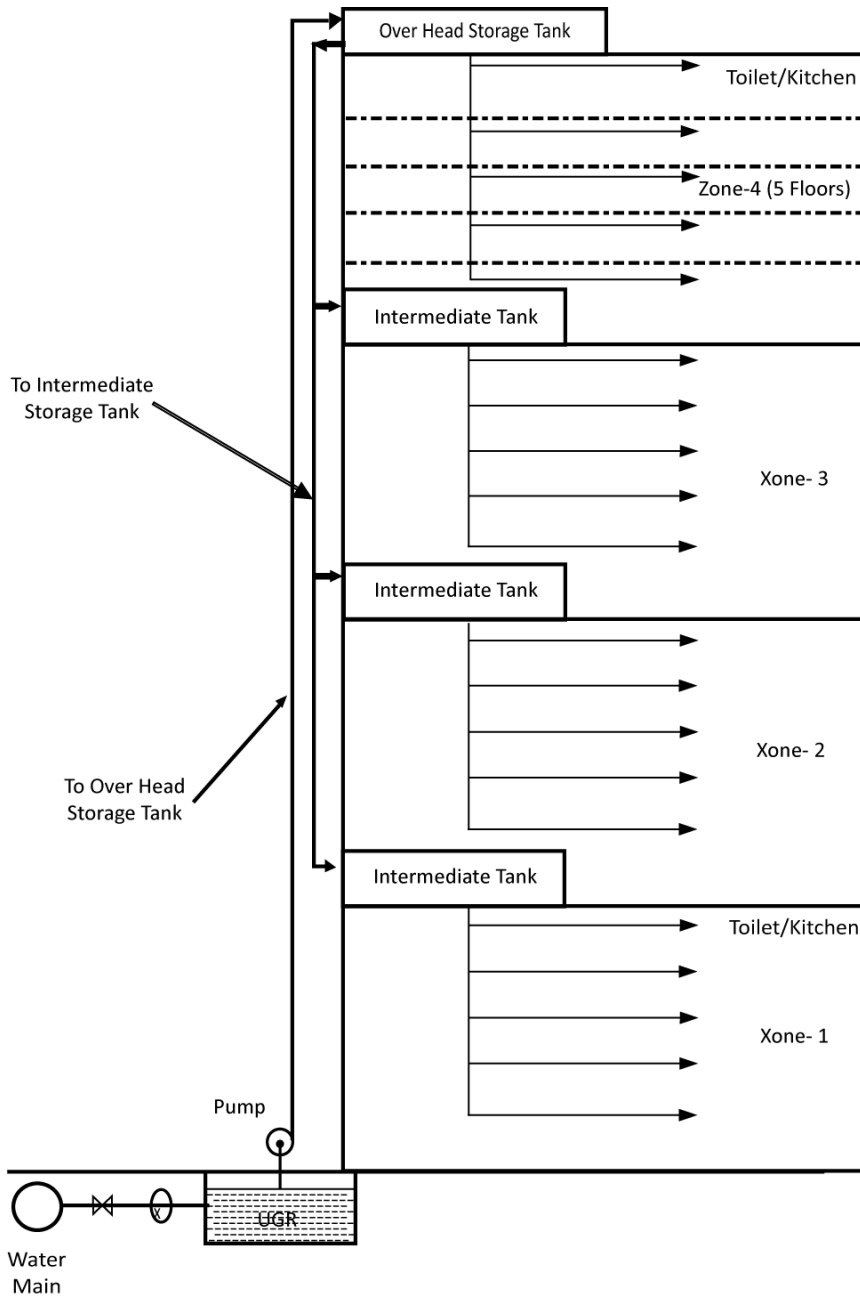


Figure 8.O.3(a) Zoning floors (5) by intermediate tanks supplied by OH storage tank

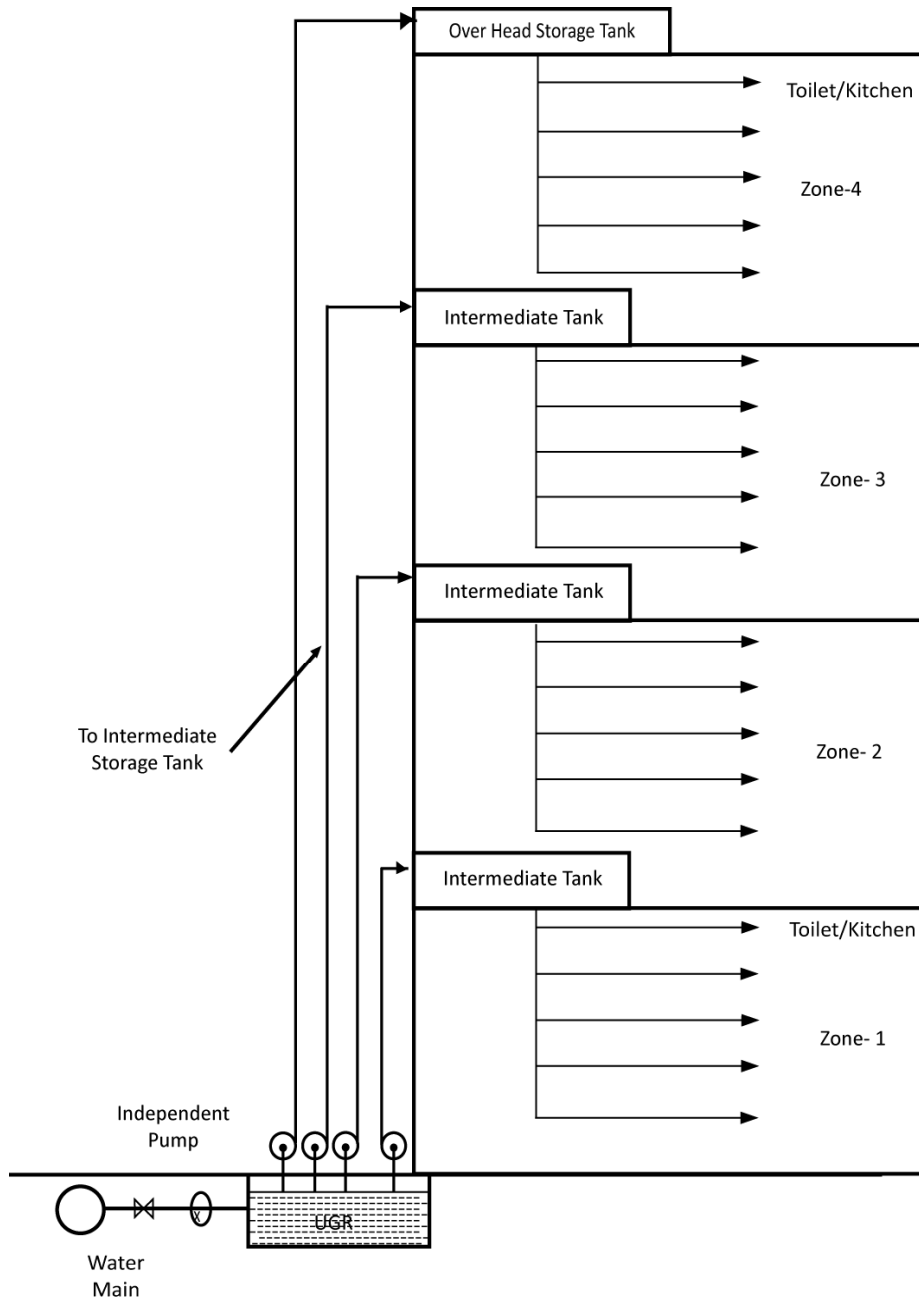


Figure 8.O.3(b) Zoning floors (5) by intermediate tanks supplied by independent pumps

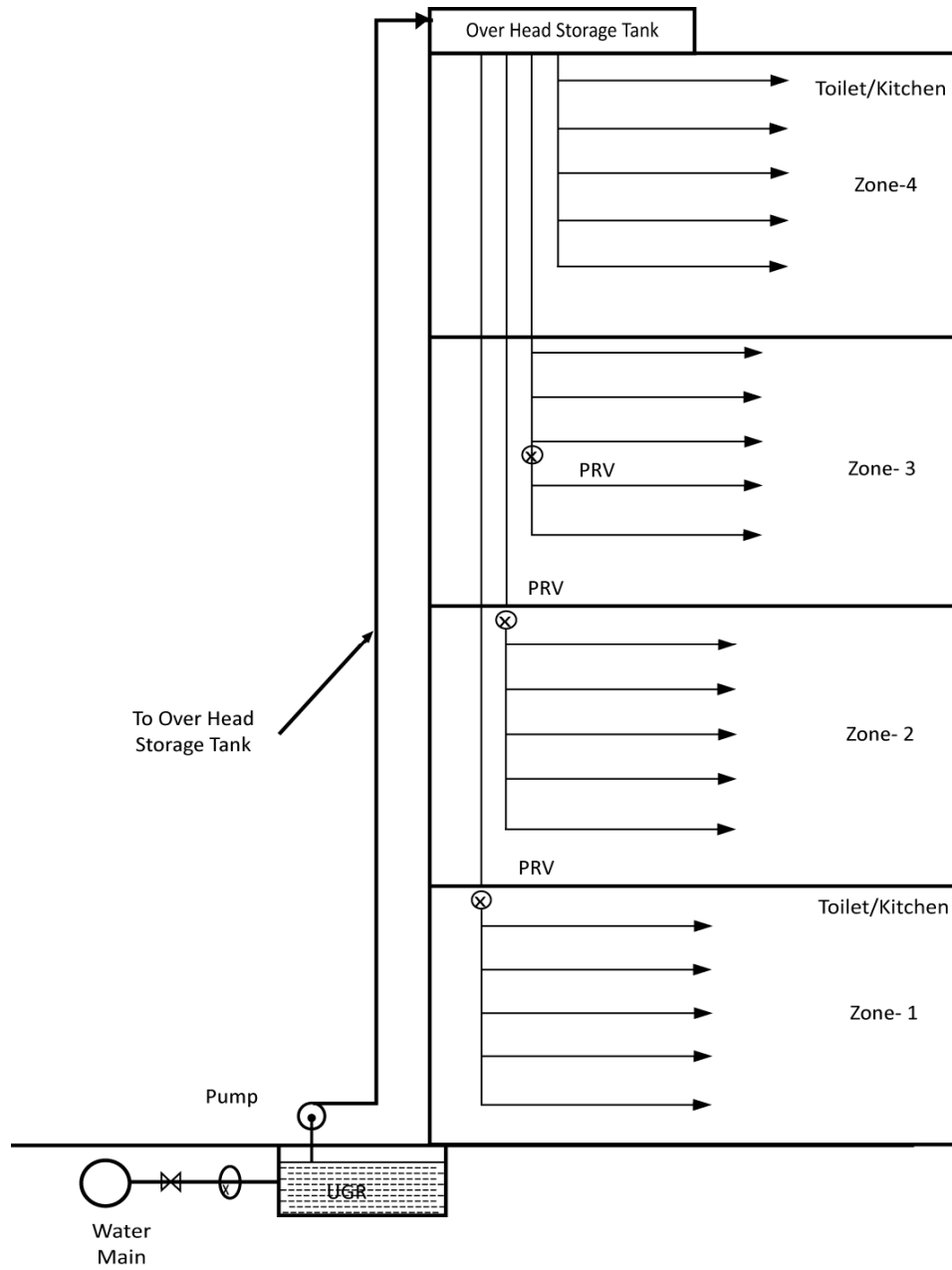


Figure 8.O.3(c) Gravity water supply system with pressure-reducing valves

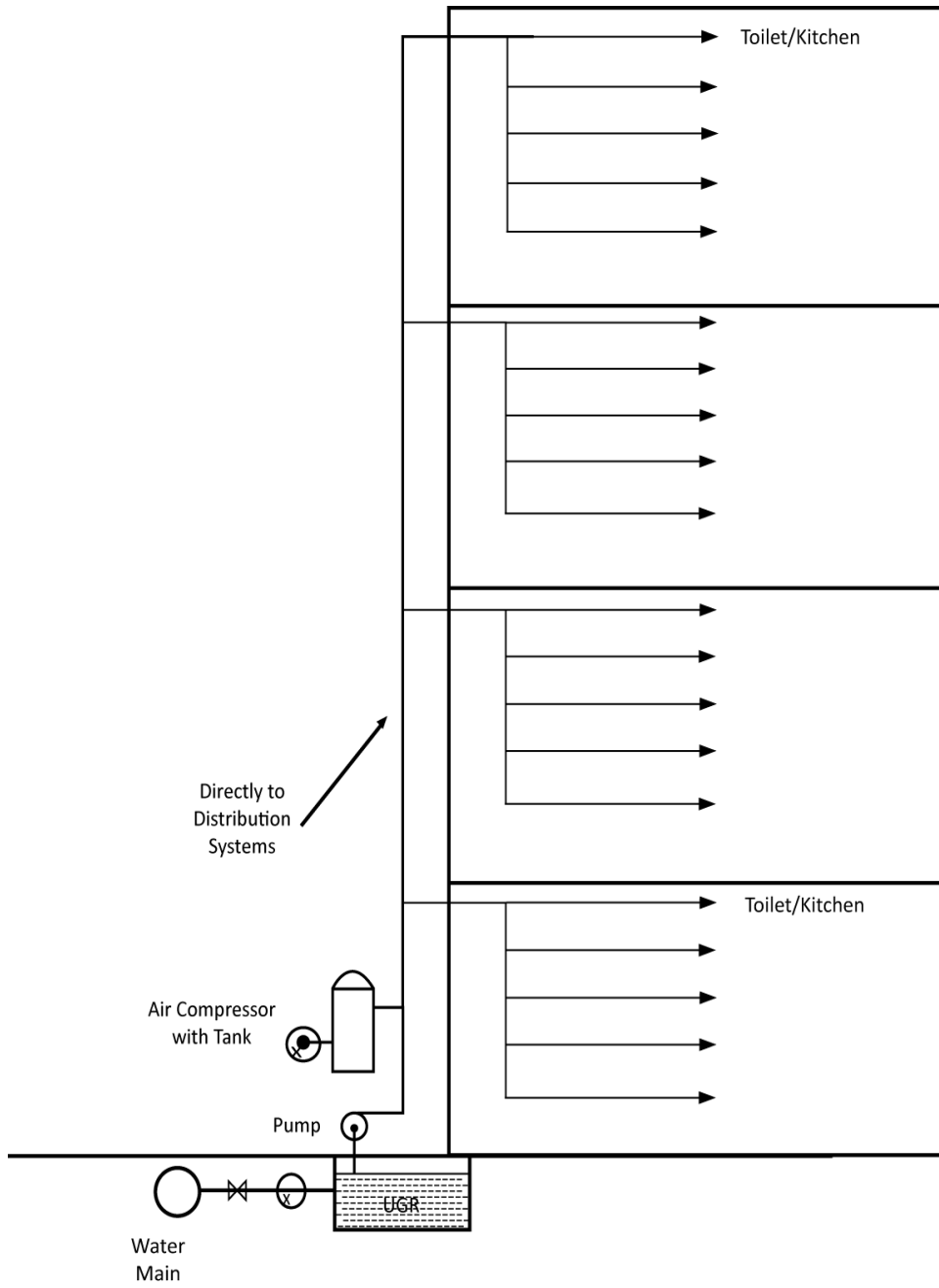


Figure 8.O.3(d) Hydro-pneumatic system of water supply in a building

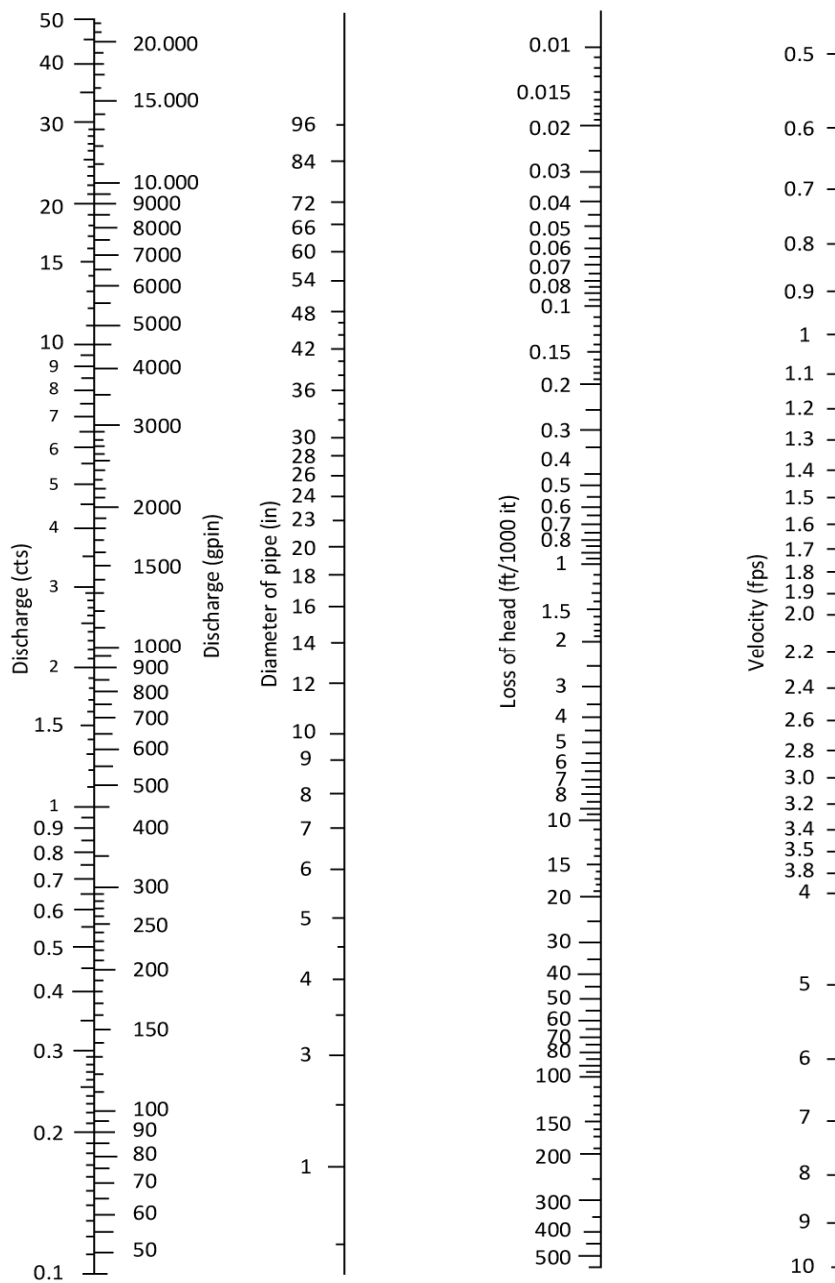


Figure 8.O.4 Hazen-Williams nomograph with roughness coefficient, C = 100

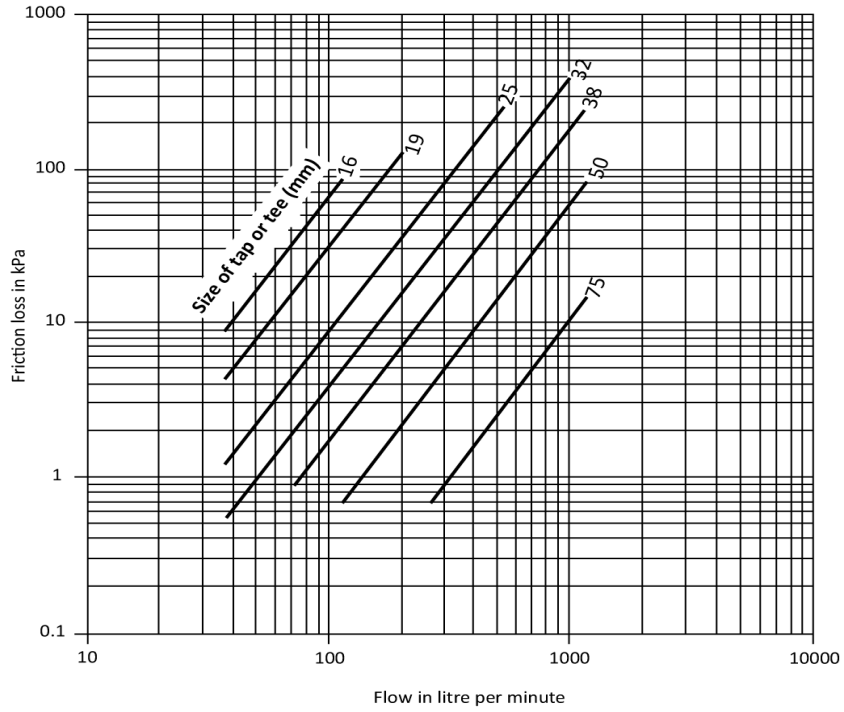


Figure 8.O.5 Friction loss through taps and tees

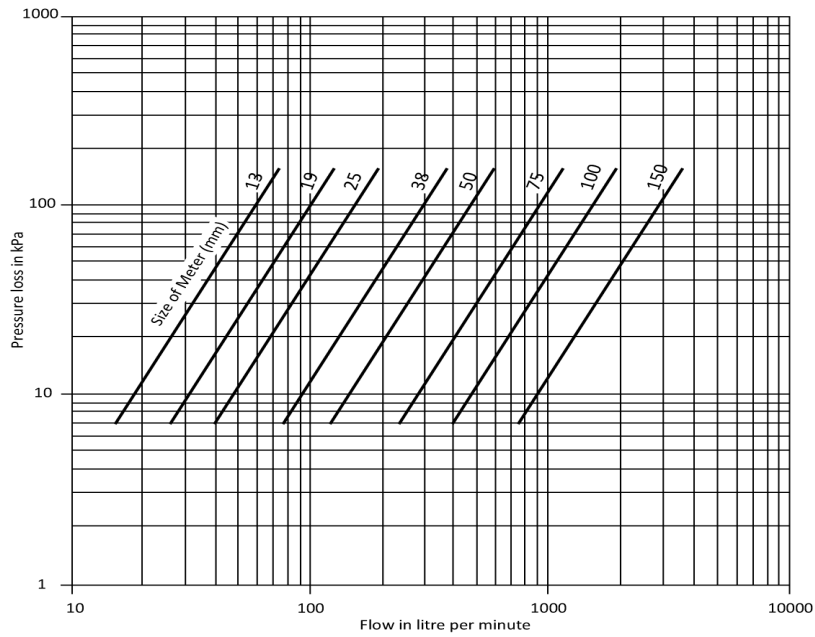


Figure 8.O.6 Loss of pressure through disc - type meter in kPa

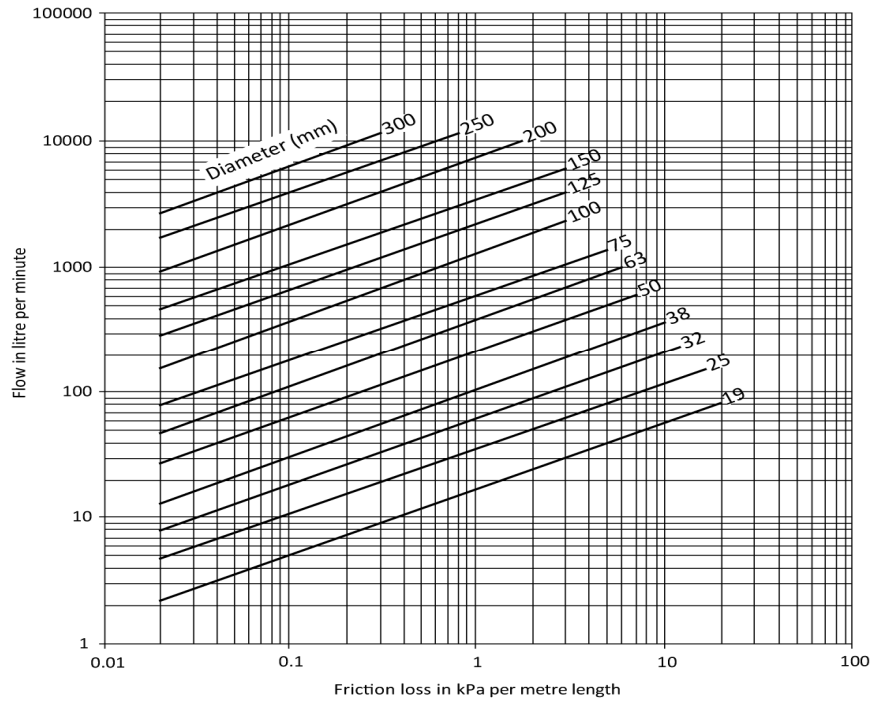


Figure 8.O.7 Friction loss in fairly rough pipe

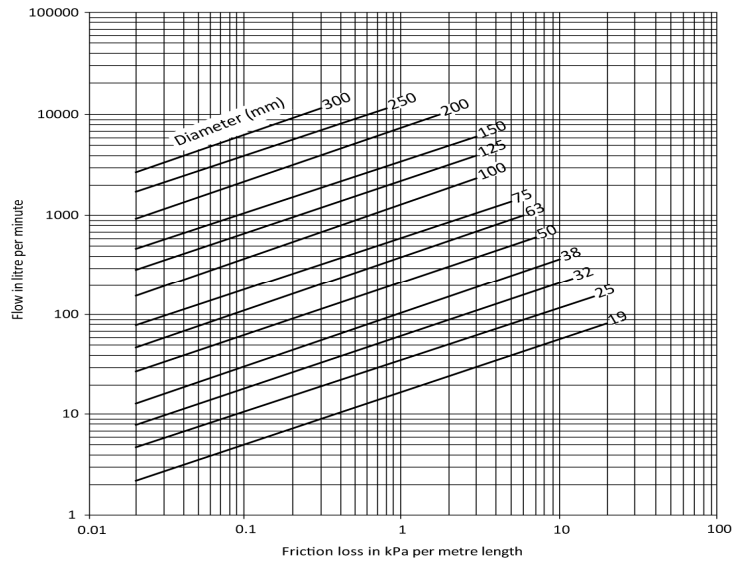


Figure 8.O.8 Friction loss in rough pipe

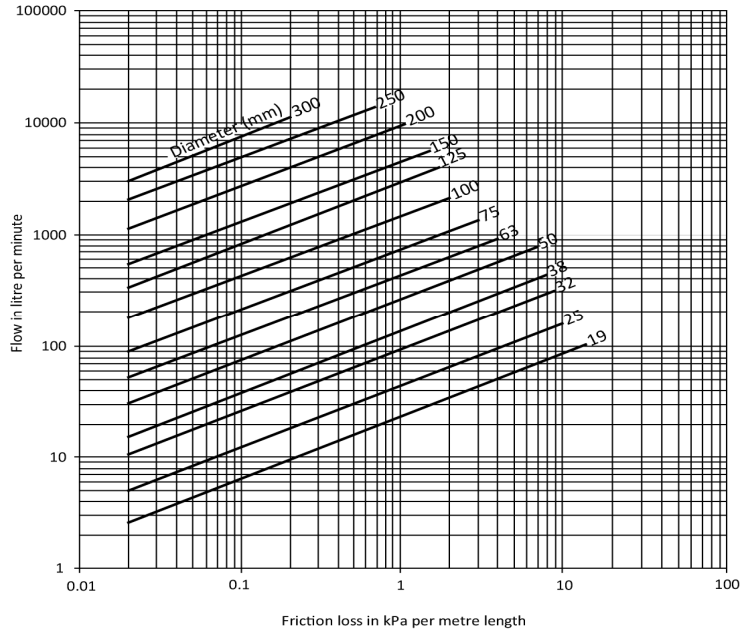


Figure 8.O.9 Friction loss in fairly smooth pipe

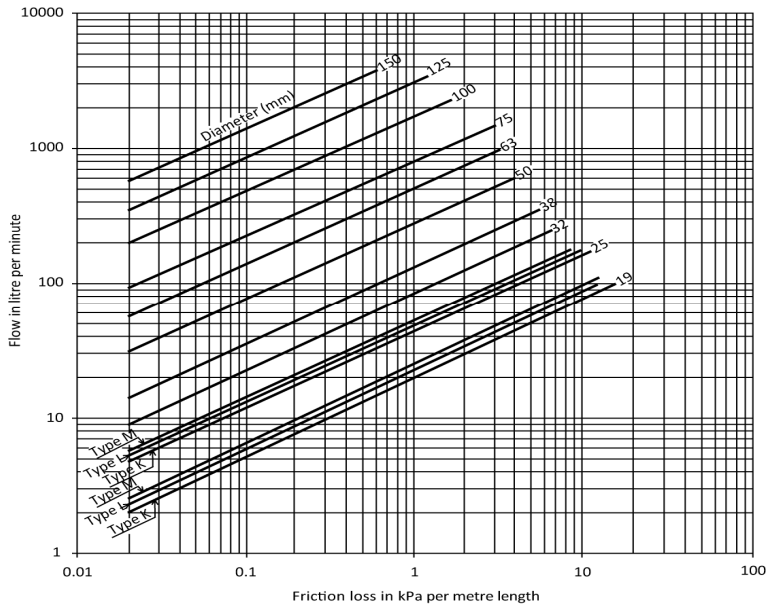


Figure 8.O.10 Friction loss in copper pipe

PART VIII
Appendix P
Recommended Water Quality for Domestic Purposes

Table 8.P.1: Water Quality Standards

Water Quality Parameters	Unit	WHO Guideline Values (2004)	Environmental Conservation Rules (ECR, 1997)
1. pH	Value	6.5 - 8.5	6.5 - 8.5
2. Turbidity	NTU	5	10
3. Color	TCU	15	15
4. Odor	TON	--	Odorless
5. Hardness (as CaCO ₃)	mg/l	500	200-500
6. Iron (Fe)	mg/l	0.3	0.3-1.0
7. Manganese, Mn	mg/l	0.4*	0.1
8. Sodium, Na	mg/l	200	200
9. Calcium, Ca	mg/l	--	75
10. Magnesium, Mg	mg/l	--	30-35
11. Potassium, K	mg/l	--	12
12. Chloride, Cl	mg/l	250	150-600
13. Nitrate, NO ₃	mg/l	50	10
14. Ammonia-Nitrogen, NH ₃ -N	mg/l	1.5	0.5
15. Sulfate, SO ₄	mg/l	250	400
16. Phosphate, PO ₄	mg/l	--	6
17. Fluoride, F	mg/l	0.6 -1.5	1
18. Mercury, Hg	mg/l	0.001	0.001
19. Arsenic, As	mg/l	0.01	0.05
20. Lead, Pb	mg/l	0.01	0.05
21. Chromium, Cr	mg/l	0.05	0.05
22. Cadmium, Cd	mg/l	0.003	0.005
23. Boron, B	mg/l	0.5	1.0
24. Aluminum, Al	mg/l	0.2	0.2
25. Nickel, Ni	mg/l	0.02	0.1
26. Copper, Cu	mg/l	2.0	1.0
27. Total Dissolved Solids, TDS	mg/l	1000	1000
28. Total Suspended Solids, SS	mg/l	--	10
29. Total Coliform, TC	CFU	0	0
30. Faecal Coliform, FC	CFU	0	0

* Health Risk Guideline Value

PART VIII
Appendix Q

Application for Permit to Construct Drainage and Sanitation System

1. Occupancy Classification: _____
2. Number of Storeys: _____
3. Location: _____
4. This application is accompanied by all required plans, drawings (showing details of materials, sizes, gradient and location of pipes and fixtures) and other details as specified in Sections 6.4.2, 6.4.3, 6.4.4 and 7.5.2 of Part 8 of the Bangladesh National Building Code.

Signature of the Plumber

Signature of the Owner or his/
her appointed person

Name and Address _____

Name and Address _____

PART VIII
Appendix R
One-Hour Rainfall

One hour rainfall values for a 25-year return period for various locations in Bangladesh may be taken from Figure 8.R.1. The figure shows different regions of equal rainfall intensity as well as isohyets at 5 mm intervals.

Rainfall for a particular location shall be obtained as follows:

- (a) When the location lies within any region (shown shaded in the map), the value marked for that region shall be taken.
- (b) For a location lying on any isohyet in this map, the value of that isohyet shall be taken.
- (c) For a location lying outside the positions (a) and (b) above, linear interpolation shall be made between the adjacent isohyets to obtain the required rainfall value.

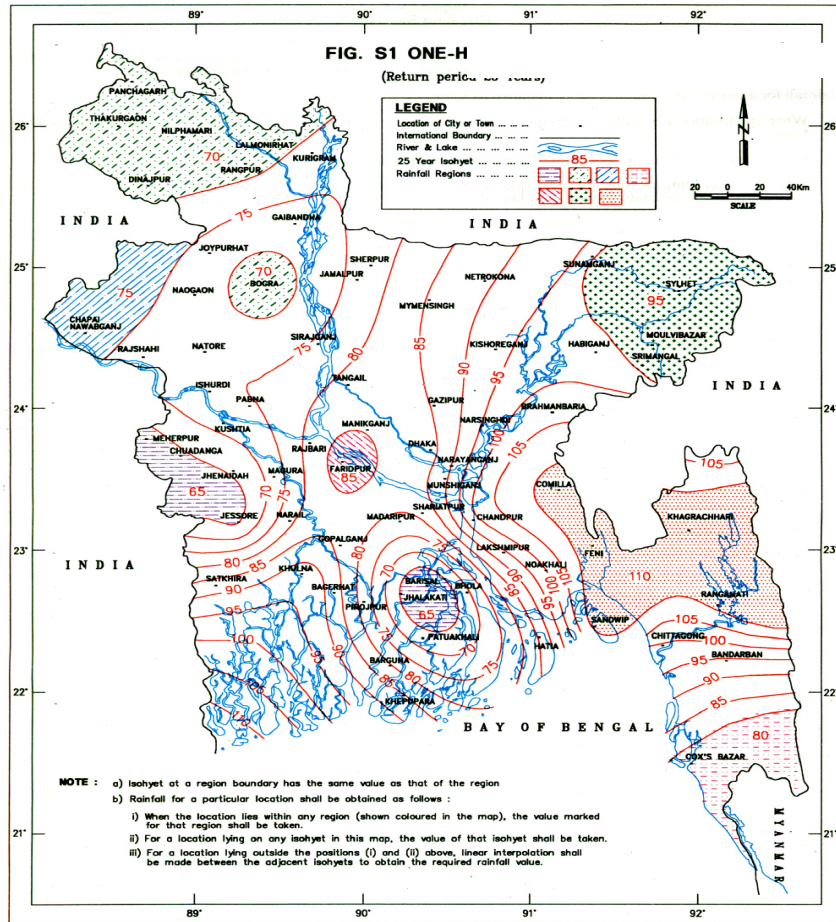


Figure 8.R.1 One-hour rainfall (in mm) map for Bangladesh

PART VIII
Appendix S
Design Guideline of a Septic Tank

The volume of a septic tank may be computed using the following equation:

$$V = PQ + PSY \quad (8.S.1)$$

Where,

V = Volume of the septic tank (litre)

P = Number of persons served

Q = Flow, litre/capita/day (*lpcd*)

The flow may be computed considering waste water flow 60% to 70% of the water consumption or on the basis of the plumbing fixtures discharging simultaneously into the septic tank, Sec 6.9.12.7. In absence of these data the waste water flow for the Occupancy groups A, C and D may be considered 120 *lpcd* for cities, 50 *lpcd* for district town and 20 *lpcd* for thanas and rural areas. For other Occupancy groups a waste water flow of 10 *lpcd* may be considered.

t = Liquid retention time, day (minimum 1 day Sec 6.9.12.11)

s = Volume required for sludge and scum (0.04 m³/capita/year, Sec 6.9.12.10)

v = Desludging frequency, year (Minimum 1 year, Sec 6.9.12.12).

If computed volume is less than 2000 litres then minimum volume of the septic tank shall be 2000 litre (Sec 6.9.12.8).

Table 8.S.1: Reduction factors for various occupancies.

Type of Development		Factor
(i) Church:	Hall-Seating capacity	0.01
	Residential Staff	1.00
(ii) School:	Primary & Secondary School-student and staff population per session	0.25
(iii) School:	Institution of Higher Learning-Total enrolment and staff	0.25
(iv) Community Centre:	Staff/worker	0.25
	Resident	1.00
	Kindergarten-student and staff population per session	0.08
	Maximum gathering	0.01

Type of Development		Factor
(v) Factory:	One shift per 24 hours	0.50
	Two/three shifts per 24 hours	1.00
(vi) Market:	Hawker /employee	0.25
(vii) Hawker/Cooked Food center:	No. of stall	1.75
(viii) Cinema:	Hall-seating capacity	0.03
	Staff	0.50
(ix) Bar & Snack Bar, Coffee- House, Restaurant:	Seating capacity	0.20
(x) Hotel:	No. of beds	0.70
	Staff/worker	0.50
(xi) Office:	No. of staff	0.50

PART VIII
Appendix T

Completion Certificate (Drainage and Sanitation Works)

Ref. No. of the Authority's permit: _____ Date: _____

This is to certify that I/We have completed the drainage and sanitation system for the building and the premises at: _____

Detailed description of the work: _____

This may be inspected, tested and approved.

Signature of the Plumber

Name and Address: _____

The Authority's Certificate

This is to certify that the above drainage and sanitation system has been completed in accordance with the provisions of the Bangladesh National Building Code. The drainage connection to the main sewer (if any) may now be made _____.

Signature of the Building Official or his

Authorized deputy

Seal

**PART VIII
Appendix U**

Determining Catchments Area for a Flat Surface

Figure 8.U.1 shows a building having flat roofs at different levels. In level 3 the area ABCD is the catchment area contributing to the rainwater down pipe RDP1.

In level 2 horizontal area EFGH and 50% of the vertical wall surface area AFHM, projecting above is the catchment area of rainwater down pipe RDP2.

For the rainwater down pipe RDP3 the catchment area will be the terrace at level 2, 3 and fifty percent of the adjacent contributory wall AFHM, GHIJ and MJLC.

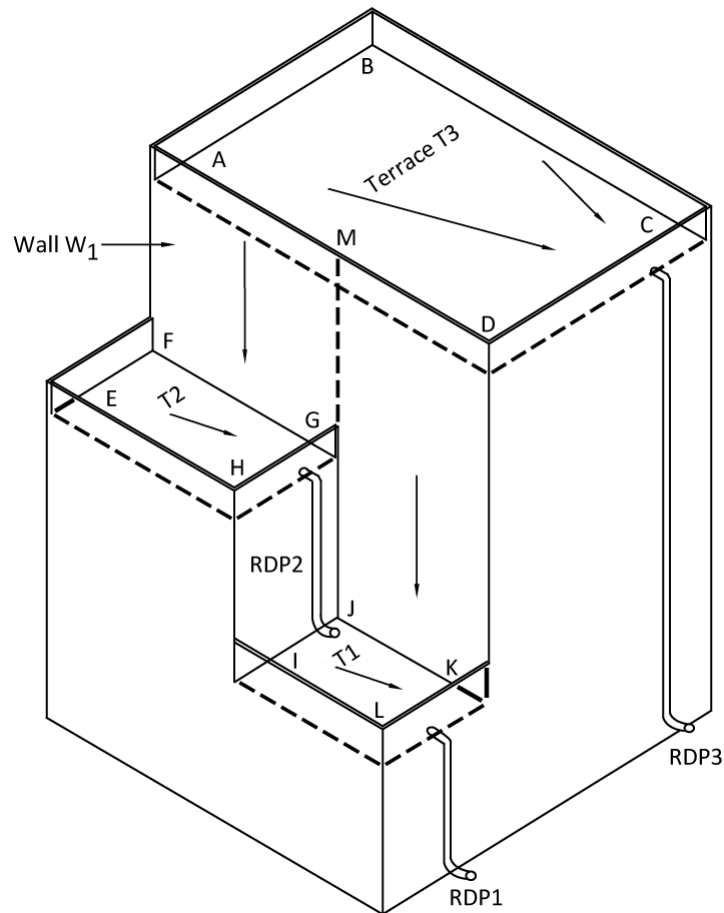


Figure U.1 Catchment area of flat roof and surface wall

PART VIII
Appendix V
Work on the Gas Supply System

This Appendix applies only to work on gas supply systems ahead of the outlet of the meter set assembly, or of the service regulator when there is no meter.

(a) Serving Gas Supplier's Main

No person, unless in the employ of or authorized by the gas supply company shall open or make connections with gas main.

(b) Serving Gas Piping

No person, unless in the employ of or authorized by the gas supply company, shall repair, alter, open or make connections to the services gas piping or do any other work on the parts of the gas supply system up to the meter set assembly or the service regulator when there is no meter.

(c) Meter or Service Regulator When a Meter is not provided

No person, unless in the employ of or authorized by the gas supply company, shall disconnect the inlet of the gas meter or service regulator when there is no meter, nor move such meter or regulator. A gas fitter may disconnect the outlet of such a meter or regulator from the house piping only when necessary. He shall make the joint at the meter or service regulator outlet when there is no meter, carefully replacing all insulating fittings or insulating parts of such fittings, and shall leave the gas turned off at the meter or regulator unless the gas supply company's rules require or allow deviation from this procedure

(d) Notify Gas Supply Company of any Repairs Needed

In case any work done by a gas fitter reveals the need for repairs or alterations on any part of the gas supply system, the gas supply company shall be notified promptly of this fact.

(e) Notify Gas Supply Company of any Leakage

If gas is leaking from any part of the gas supply system, a gas fitter or plumber not in the employ of the gas supply company may make necessary repairs and shall promptly notify the gas supply company.

PART VIII
Appendix W
Documentation for Piping Installation

The gas supply company requires the following to be fulfilled by the consumer(s) for having gas supply from its distribution piping system:

- (a) Application for gas connection in prescribed form along with the approved plan of the building where the gas is to be used. If the building is not approved by the Authority its plan is to be prepared by an approved contractor of the gas supply company.
- (b) An approved contractor of the gas supply company shall prepare the plan of the gas piping system for the building. The plan is to include plan and elevation of the proposed piping system. The plan so prepared shall be submitted to the gas supply company.
- (c) Installation of the piping system as approved by the gas supply company shall be carried out by an approved contractor of the gas supply company.
- (d) Completion report of the installation of the piping system (using the approved drawing) along with the pressure and leak tests by the approved contractor shall be submitted to the gas supply company. The pressure test is to be witnessed by the approved official of the gas supply company.
- (e) Completion report mentioned in (d) above is to include the papers related to the permission from the Authority for digging/cutting the road for taking the connection from the main supply line lying under the road, needed.
- (f) The legal owner of the building shall sign an agreement with the gas supply company using the prescribed agreement document of the gas supply company prior to having the gas supplied to his/her premises.

Chapter 1 Applicability and Implementation

1.1 General

The provisions of this Part are intended to maintain or increase the current degree of public safety as well as health and general welfare in existing buildings while permitting alteration, addition to or change of use. In addition, certain environmental measures to make the existing building stock sustainable, is also a requirement that needs to be addressed to make buildings more energy efficient and environmentally responsive. This concept is introduced in Chapter 2 of this Part.

1.2 Applicability

1.2.1 General

The provision of this Part shall apply to existing buildings that will continue to be or are proposed to be in occupancy groups A, B, C, D, E, F, G, H, I, J, K, L and M. The provisions shall not apply to buildings of historical or architectural value identified and classified by designated authorities. For buildings of historical or architectural value buildings, the provisions of Sec 1.5: Historic or Architecturally Valuable Buildings, of Part 1 Sec 1.16 Buildings and Places of Historical or Architectural Value, of Part 3 and Part 9 Chapter 3 shall be applicable.

Certain provisions to existing buildings and land-use even when additions, alterations or amendments not proposed are included in Sec 2.3 of this Part.

1.2.2 Change in Use

1.2.2.1 No change in use of any existing building shall be made without permission from the permitting authority.

1.2.2.2 No change in use of an existing building shall be allowed if the proposed use is not in conformity with land use pattern as referred in Sec 1.3 Part 3 and within the permitted occupancy classes of Sec 1.4 Part 3 as may be determined by the city or area development authorities having jurisdictions.

1.2.2.3 Where an existing building is changed to a new use group classification, the provisions for the new use group in this Code shall be used to determine compliance.

1.2.3 Part Change in Use

1.2.3.1 No change in use of any part of an existing building shall be made without permission from the permitting authority.

1.2.3.2 Where a portion of the building is changed to a new use group classification, and that portion is separated from the remainder of the building with fire separation assemblies having a fire resistance rating as required by Part 4, Fire Protection, for the separate uses, the portion changed shall be made to conform to the provisions of this Code.

1.2.3.3 Where a portion of the building is changed to a new use group classification, and that portion is not separated from the remainder of the building with fire separation assemblies having a fire resistance rating as required by Part 4, Fire, for the separate uses, the provisions of this Code which apply to each use shall apply to the entire building. Where there are conflicting provisions, those requirements which secure the greater public safety shall apply to the entire building or structure.

1.2.4 Additions

1.2.4.1 No addition to any existing buildings shall be made without permission from the permitting authority.

1.2.4.2 Additions to existing buildings shall comply with all the requirements of this Code for new constructions as set forth in Part 3 of this Code and shall comply with fire requirements set forth in Part 4 of this Code.

1.2.4.3 The combined height and area of the existing buildings and new additions shall not exceed the height and open space requirements for new buildings specified in Part 3 of this Code.

1.2.4.4 Where a separating wall that complies with Part 4, Fire Protection, is provided between the addition and the existing building, the addition shall be considered as a separate building.

1.2.5 Alterations

1.2.5.1 An existing building or portion thereof which does not comply with the requirements of this Code for new construction (Part 3) shall not be altered in such a manner that results in the building being less safe or sanitary than such building is at present.

1.2.5.2 If, in the alteration the present level of safety or sanitation is to be reduced, the portion altered shall conform to the requirements of this Code.

1.2.6 Removal

1.2.6.1 Any construction within the site which does not have approval of the appropriate authority must be removed before any new addition, alteration or change of use is carried out. All other types of existing construction and their changes shall comply with Sections 1.2.4 and 1.2.5 of this Part.

1.2.6.2 Before demolishing a building of construction Type 1 Part 4 Fire Protection the owner shall notify all utilities having service connections within the building or plot, such as water, gas, electricity, sewer and other connections.

1.2.6.3 A permit to demolish a building shall not be issued until a clearance is obtained from utilities stating that their respective service connections and appurtenant equipment, such as, meters and regulators have been removed or sealed and plugged in a safe manner.

1.3 Implementation

1.3.1 Investigation and Evaluation

For the proposed works relating to alteration, addition to and change of use, the owner of the building shall cause the existing buildings to be investigated and evaluated by competent professionals in accordance with the provisions of this Code.

1.3.2 Structural Analysis

1.3.2.1 The owner shall have a structural analysis of the existing building carried out by professional experts to determine the adequacy of all structural systems for the proposed alteration, addition or change of use.

1.3.2.2 The existing building together with the addition or alteration shall be capable of supporting the minimum load requirements specified in Part 6: Structural Design of this Code.

1.3.2.3 For Detail Engineering Assessment (DEA) of existing light manufacturing factory including readymade garment factory buildings, minimum live load of manufacturing floor shall be considered as 3 kN/m² except stacking and storage area where the minimum live load shall be 6 kN/m². However, if retrofitting is required live load for retrofitting design shall be taken according to the load requirements specified in Part 6: Structural Design of this Code.

1.3.3 Submittal

The results of the investigation and evaluation as required in Sec 1.3.1 above along with all proposed compliance alternatives shall be submitted to the Building Official for permission to implement addition, alteration or change of use.

1.3.4 Determination of Compliance

The Building Official shall examine all relevant documents, as specified by the authorities, and determine whether the existing building, with the proposed additions, alterations or change of use, complies with the provisions specified in this Code for the occupancy classification and type of construction.

Chapter 2 Evaluation and Compliance

2.1 Evaluation

The evaluation of the existing building with the proposed additions, alterations or change of use, shall take into consideration the planning requirements as well as those relating to public safety and environmental sustainability.

2.1.1 Planning Requirements

2.1.1.1 The permitting authority through building officials shall determine if any provisions of this Code are violated by the proposed change of use, addition or alteration works.

2.1.1.2 The general requirements for buildings in various occupancy classes and types of construction are specified in Part 3 and Part 8 of this Code. These include :

	Item Description	Reference
(a)	Land use classification and permitted use	Sec 1.3 Chapter 1 Part 3
(b)	Requirement of plots	Sec 1.5 Chapter 1 Part 3
(c)	Means of access	Sec 1.7 Chapter 1 Part 3
(d)	Staircase	Sec 1.14.5 Chapter 1 Part 3
(e)	Universal accessibility requirements	Chapter 3 and Appendix D, Part 3
(f)	Open spaces within a plot; minimum separation of buildings in the same plot; road front, side and rear open spaces, Permitted Construction in the Mandatory Open Space	Sec 1.8 Chapter 1 Part 3
(g)	General height and area limitations based on Road Width	Sec 1.9.2 Chapter 1 Part 3
(h)	General height and area limitations based on FAR	Sec 1.9.3 Chapter 1 Part 3
(i)	Off street (on-site) parking spaces	Sec 1.10 Chapter 1 and Appendix F, Part 3
(j)	Street encroachment	Sec 1.11 Chapter 1 Part 3

	Item Description	Reference
(k)	Community open space and amenities for various types of buildings	Sec 1.12 Chapter 1 Part 3
(l)	Ventilation requirements :	
	Natural	Sec 1.19 Chapter 1 Part 3
	Artificial	Chapter 2 Part 8
(m)	Lighting and illumination requirements	Sec 1.19 Chapter 1 Part 3
	Electric lighting	Chapter 1 Part 8
	Day lighting and Supplementary lighting system	Sec 4.5.1 Chapter 4 Part 3
	Electrical and electronic engineering services for buildings	Chapter 1 Part 8
(n)	Sanitation and drainage requirements	Sec 1.19 Chapter 1 Part 3
	Site drainage and run-off coefficient	Sec 4.3.2 Chapter 3 Part 3
	Internal water management	Sec 4.6 Chapter 4 Part 3
	Water Supply	Chapter 5 Part 8
	Sanitary Drainage	Chapter 6, Part 8
(o)	Minimum dimension of habitable and non-habitable parts of the buildings	Sec 1.14.2.2 and Sec 1.19.6, Chapter 1 Part 3

2.1.1.3 The existing building with proposed alteration or addition shall conform to the requirements of new buildings in the proposed occupancy classification. The proposed alteration or addition shall not make the building less sanitary than present.

2.1.1.4 To promote the preservation of historic buildings, open space or unique architectural/ cultural resources, the local permitting authority shall transfer development rights (TDR), as decided by the authority, to owners as compensation, in accordance with Appendix E, Part 3 of this Code.

2.1.2 Safety Requirements

2.1.2.1 Additions or alterations to an existing building or structure is not to be made if such additions or alterations cause the building or structure to be unsafe or more hazardous based on fire safety, life and structural safety and/or environmental degradation.

2.1.2.2 The fire safety requirement shall take into consideration the structural fire resistance, smoke and fire detection, fire protective signaling and fire suppression system feature of the facility and shall satisfy the requirements of various elements for Types 1, 2 and 3 fire resistive buildings.

2.1.2.3 The fire resistance of the wall used for compartmentalization of a building shall not be less than that specified in subsections of Sec 2.4, Part 3 of this Code.

2.1.2.4 Duct penetrations of this wall shall not be permitted. Ferrous or copper piping and conduit shall be allowed to penetrate or pass through the wall if the openings around such piping and conduit are sealed with impervious noncombustible materials sufficiently tight to prevent fire transfer of smoke or combustible gases from one side of the wall to the other side and are so maintained.

2.1.2.5 The fire door between compartments serving as horizontal exit shall be so installed, fitted and provided with gaskets that such fire door will provide a substantial barrier to the passage of smoke.

2.1.2.6 The floor/ceiling shall be of such construction that the fire resistive integrity between stories is maintained.

2.1.2.7 The smoke detection capability within the facility based on the location and operation of automatic fire detectors shall be evaluated with respect to the requirements of Chapters 3 and 4 of Part 4 for various Occupancies.

2.1.2.8 Where a fire protecting alarm and signaling system is provided, the capability of the system shall also be evaluated (Part 4).

2.1.2.9 The ability of the natural or mechanical venting, exhaust or pressurization system to control the movement of smoke from a fire shall be evaluated.

2.1.2.10 The shaft and exit enclosures shall satisfy the fire protection requirements as specified in Part 4 of this Code.

2.1.2.11 The configuration, characteristics and support features for means of egress in the facility including the capacity of and the number of exit routes available to the building occupants shall be evaluated and the adequacy of the means of egress routes leading to a safe area shall be examined. The length of the exit access travel path in which building occupants are confined to a single path of travel shall be evaluated. The length of exit access travel to an approved exit shall also be evaluated with respect to the exit requirements for various occupancies as detailed in Part 4 of this Code.

2.1.2.12 The efficiency and effectiveness of the elevator equipment and controls that are available to the fire department to rescue building occupants from upper floors during a fire when such equipment is installed shall be evaluated.

2.1.2.13 The presence of and reliability of means of egress emergency lighting system shall be evaluated.

2.1.2.14 The ability to suppress fire based on the installation of automatic sprinkler and stand pipe systems shall be evaluated (Chapters 4 and 5, Part 4).

2.1.2.15 The lightning protection of the building shall satisfy the requirements specified in Chapter 1 Part 8.

2.1.3 Egress Requirements

2.1.3.1 Addition to or alteration or changes of use of a building shall not be permitted if such addition or alteration or change of use causes violation of the egress requirements specified in Chapter 3 Part 4.

2.1.3.2 Permissions shall not be granted for any such work that will obstruct or block or hamper the existing means of egress of the building or any other building unless an equivalent and adequate means of egress is provided.

2.1.4 Structural Requirements

2.1.4.1 Additions to, alterations or change of use of an existing building or structure shall not be permitted if they cause an overloading or instability of the structural elements including the foundation.

2.1.4.2 On evaluation, if the structure of the existing building is found in non-conformity with the safety provisions of this code, the building will be declared as 'unsafe building' by the authority.

2.1.4.3 For all buildings identified as an 'unsafe building' the authorities shall identify measures that remove danger to the structure, life or property so that the building can be made safe for occupation.

2.1.4.4 Buildings that cannot be made structurally safe will be declared 'unfit for occupation' and demolished by the authorities.

2.1.5 Environmental Requirements

Additions to, alterations or change of use of an existing building or structure shall not be permitted if they cause environmental degradation and unsustainable development in the locality.

2.2 Compliance

2.2.1.1 When an evaluation is carried out as described above and the existing building with the proposed alteration, addition and/or change of use satisfy the requirement specified for the relevant occupancy classification, the results of the evaluation shall be accepted by the Building Official.

2.2.1.2 The owner shall fully comply with the results of such evaluation for the existing building with the proposed alteration, addition and/or change of use for the relevant occupancy classification and its recommended remedies if relevant as set forth in Sec 2.1.4 above.

2.3 Sustainability Measures for Existing Buildings

2.3.1 When there are no proposals for additions, alterations or change of use, to make existing building stock sustainable, environmentally responsive and energy efficient, the Authority may propose necessary measures after evaluating the condition of the existing buildings. When it is found that environmental degradation is taking place or such is feared by experts, the measures to be proposed may include, but not restricted to the following:

- (a) introduction of renewable energy
- (b) installation of rainwater harvesting
- (c) installation of ground water recharge systems
- (d) introduction of low energy sources

2.3.2 Any sustainability and/or energy efficiency measure suggested shall comply with relevant requirements in Chapter 4 Part 3 of this Code.

Chapter 3 Conservation

3.1 Scope

Historical places, buildings, objects and manifestation of cultural, scientific, symbolic, spiritual and religious value are important expressions of the culture and heritage, identity and religious beliefs of societies. Their role and importance, particularly in the light of the need for cultural identity and continuity in a rapidly changing world, need to be promoted.

Buildings, spaces, places and landscapes charged with historical, cultural, spiritual and religious value represent an important element of stable and humane social life and community pride. Without appropriate restoration / conservation, the architectural evolution in relation to socio cultural concept of a country's heritage remains misinterpreted, and can lead to virtual disappearance.

National legislation and international treaties and regulations aim to strike a balance between the need for development and the need to conserve the environment for the future.

3.2 Terminology and Conceptual Definitions

3.2.1 Conservation

This is the process of retention of existing buildings or groups of buildings, landscapes etc. and taking care not to alter or destroy character or detail, even though repairs or changes may be necessary. Conservation conventionally is concerned to preserve as much original fabric as possible.

3.2.2 Restoration

This is the process of carrying on alterations and repairs to a building with the intention of restoring it to its original form, often involving reinstatement of missing or badly damaged parts, so it usually includes replication. As far as possible, efforts are made to replicate the materials and construction techniques of the original in this endeavor.

While often necessary after a disaster, it is generally regarded as more drastic than conservation, which suggests retention, repair and maintenance.

3.2.3 Area Conservation/Historic Districts

Area conservation includes conservation of any building or portion thereof, that fall under historic districts and/or abutting Heritage Streets as listed by the National Committee for Heritage listing.

3.2.4 Structures of Architectural Significance

Structures of architectural significance include any building or portion thereof with architectural significance, which may not be a historic building, but is designated as of significance for its architectural qualities as designated by the standing committee for Heritage listing.

3.3 Aims of Conservation

3.3.1 Conservation, rehabilitation and culturally sensitive adaptive reuse of urban, rural and architectural heritage shall be in accordance with the sustainable use of natural and human made resources. Access to culture and the cultural dimension of development is of utmost importance, benefiting all the people who have such access.

3.3.2 In order to promote historical and cultural continuity and to encourage broad civic participation in all kinds of cultural activities, the Government at the appropriate levels, including the local authorities, should undertake the following:

- (a) Identify and document, whenever possible, the historical and cultural significance of areas, sites, landscapes, ecosystems, buildings and other objects and manifestations
- (b) Establish conservation goals relevant to the cultural and spiritual development of the society;
- (c) Promote awareness of heritage in order to highlight its value and the need for its conservation and the financial viability of rehabilitation;
- (d) Encourage and support the local heritage and cultural institutions, association and communities in their conservation and rehabilitation efforts and inculcate in children and youth an adequate sense of their heritage;
- (e) Promote adequate financial and legal support for the effective protection of cultural heritage;
- (f) Promote education and training in traditional skills in all disciplines appropriate to the conservation and promotion of heritage.

3.4 Objectives of Conservation

To integrate development with conservation and rehabilitation goals, the Government at appropriate levels, including Ministries, local authorities and municipalities, shall undertake the following:

- (a) Recognizing that historical and cultural heritage is an important asset, strive to maintain the social, cultural and economic viability of historically and culturally important sites and communities.

-
- (b) Preserve the inherited historical settlement and landscape forms, while protecting the integrity of the historical urban fabric and thereby guiding new construction in historical areas;
 - (c) Provide adequate legal and financial support for the implementation of conservation and rehabilitation activities, in particular through adequate training of specialized human resources;
 - (d) Promote incentives for such conservation and rehabilitation to public, private and non-profit developers.
 - (e) Promote community based action for the conservation, rehabilitation, regeneration and maintenance of neighborhoods.
 - (f) Support public and private sector and community partnership for the rehabilitation of inner cities and neighborhoods.
 - (g) Ensure the incorporation of environmental concerns in conservation and rehabilitation projects;
 - (h) Take measures to reduce acid rain and other types of environmental pollution that damage to buildings and other items of cultural and historical value.
 - (i) Adopt human settlement planning policies, including transport and other infrastructure policies that avoid environmental degradation of historical and cultural areas.
 - (j) Ensure that the accessibility concerns of people with disabilities are incorporated in conservation and rehabilitation projects.

3.5 Ethics of Conservation

The following standards of conservation ethics shall be rigorously observed in conservation works:

- (a) The condition of the building must be recorded before any intervention.
- (b) Historic evidence must not be destroyed, falsified or removed.
- (c) Any intervention must be the minimum necessary.
- (d) Any intervention must be governed by unswerving respect for the aesthetic, historical and physical integrity of cultural property.
- (e) All method and material used during treatment must be documented.

3.6 Guidelines for Conservation

Any proposed intervention should:

- (a) be reversible or repeatable, if technically possible, or
- (b) not prejudice a future intervention whenever this may become necessary;
- (c) not hinder the possibility of later access to all evidence incorporated in the objects;
- (d) allow the maximum amount of existing material to be retained;
- (e) be harmonious in color, tone, texture, form and scale, if addition is necessary. But should be less noticeable than original material, while at the same time being identifiable;
- (f) not be undertaken by conservator/restorer who are insufficiently trained or experienced.

3.7 Listing of Heritage Building or Area

3.7.1 Aim and Objectives of Listing

Since a large part of Bangladesh's cultural heritage has so far remained undocumented, preparing an inventory of heritage buildings worthy of conservation is the most important task with which to begin the process of conservation.

This inventory will become National Register of Historic and Architectural Properties. It attempts to create a systematic, accessible and retrievable record of the built heritage of this country. It will serve as resource material for developing heritage conservation policies and regulations.

The primary aim of listing is to document the fast disappearing built heritage and then present it to scholars and the general public in a user-friendly format, which aids conservation by generating public awareness. Once a property/ building is included in such a list, it becomes justifiable to undertake necessary conservation activities by formulating special regulations for its conservation or according it due protection under Town Planning Acts or Detail Area Plan. Ideally, the footprints of all listed buildings along with the guidelines referred in Sec 3.8.2 below should be included in the Master Plan documents of all cities.

3.7.2 Listing and Protection of Buildings or Area of Historic Value

All historic buildings and places identified, listed and classified so by the appropriate agency of the Government under the Act of Antiquity shall be deemed to be protected. Any change of use, repair, alteration or extension of such buildings shall be in compliance with the requirements of this Code as referred in Sec 1.18 Chapter 1 Part 3, and with those of the Department of Archaeology of the Government.

3.7.3 Listing of Projects or Work of Architectural Value

Buildings and works under the jurisdiction of and identified by the Authority as having architectural value shall be deemed protected. The owner of any such building may also apply to the Building Official for enlistment as a building with architectural value. To be so identified, a building shall have been in existence for at least 20 years from the date of its completion. To determine whether the building or work is architecturally valuable, the Authority shall appoint a standing committee comprising noted experts from the fields of Architecture, Planning, Engineering, History, Art, Literature or any other discipline which may be deemed relevant. The committee shall identify a building as architecturally valuable if, in their judgment, the building possesses distinctive architectural features, has cultural or symbolic value, has become part of the heritage, or bears testimony of some historical event. In addition to satisfying the requirements of Sec 1.18.2 Chapter 1 Part 3 any proposed repair, alteration or addition to such buildings must also have the approval of the standing committee who shall have to be satisfied that the proposed changes will not impair the aesthetic quality and architectural character of the building.

3.7.4 Publication and Web Notification

Periodically, this database of listed heritage should be made more comprehensive and the information compiled should be available in published form and online. It should also be made compatible with similar registers of other countries to facilitate international research. The list of gazetted historic buildings shall be available on the websites of all concerned departments or development authorities or in the Government website on heritage conservation.

3.7.5 Selection Criteria for Listing

Conservation must preserve and if possible enhance the message and values of cultural properties. These values help systematically to set overall priorities that will determine whether a property is worthy of listing. The values assigned to cultural property come under three major headings:

A. Cultural values	B. Use values	C. Emotional Values
• Documentary	• Functional	• Wonder
• Historic	• Economic	• Identity
• Archaeological age and scarcity	• Social	• Continuity
• Aesthetic	• Political and ethnic.	• Spiritual and symbolic.
• Architectural		
• Townscape, landscape and ecological		
• Technological and scientific.		

After analyzing these values they should be condensed into a statement of the significance of the cultural property, whether or not the property is worthy for listing.

3.7.6 Detailed Format for all Listed Properties

Information for each building or site should be recorded as per format as described below.

- (a) Each proforma shall contain information about persons engaged in the process of listing and review. Listing shall be carried out by or under the supervision of experienced conservation architects.
- (b) At least one photograph of the property/building shall be recorded for identification purposes. All significant elements of the property shall also be photographed. All photographs should be properly catalogued.
- (c) A conceptual plan (if available, a measured drawing) should be given for each building/area to be listed.
- (d) Any additional information related to or affecting the built heritage of the city/town/region documented and its conservation should be included as appendices, for example: laws and regulations on planning and conservation, etc.

3.7.7 Grading of Historic Buildings

The primary objective of listing is to record extant architectural heritage and sites. But the outcome of this process should invariably be to grade the listed heritage into a hierarchical series. This process must be undertaken in a rigorous and transparent manner by a multi-disciplinary team of experts whose recommendations should be available for public scrutiny. The importance of this process determines the basis for subsequent conservation decisions. Such hierarchical categorization facilitates the prioritization of decisions relating to the future of architectural heritage and sites.

The listed historic buildings and sites may further be classified in descending order of importance into the following categories:

- (i) Grade I and I* – Buildings of outstanding merits, in which every effort should be made to preserve. (Buildings and sites classified as Grade I* are already listed as per Antiquity Act)
- (ii) Grade II – Buildings of special merits; in which efforts should be made to preserve selectively.
- (iii) Grade III – Buildings of some merit; in which preservation in some form would be desirable and alternative means could be considered if full preservation is not practicable.

Grade I and II should be conserved in accordance with the provisions of official and legal manuals of practice (for example, Department of Archaeology's Works Manual). Endorsed grading may be subject to review and revision. The grading system is an internal administrative mechanism carrying no legal effect.

3.7.8 Upgrading of the List

The process of listing should be constantly upgraded and the updated list should maintain the availability of fresh information of the listed building or site.

3.8 Implementation Strategy

3.8.1 Community Participation

In order to ensure community participation in the conservation process, scaled drawings of the proposed conservation shall be appended to the site during construction so that the public may become accustomed to the proposal and have the option of registering their opinion regarding the same.

If necessary the proposals shall be amended if strong public opinion is found against the proposal for conservation / restoration.

3.8.2 Protection of the Building or Site

3.8.2.1 A clear space around each monument shall be formed as an immediate environmental protection to the monument. This area should follow, as the case may be, the original line of the enclosure wall.

3.8.2.2 In rural or suburban setting no new structures/built forms of any size, shape shall be allowed to develop within the UNESCO/UNDP suggested area of half a mile radius from the epicenter of the monument under consideration.

3.8.2.3 In rural or suburban settings, a parcel of land representing approximately a circular area of a half mile radius of the farmland immediately surrounding the heritage building/monument shall be acquired to protect it from encroachment

3.8.2.4 In urban areas or metropolitan cities the radius of this protected zone shall be 250 m from the heritage building or area.

3.8.2.5 In both rural and urban areas, an immediate buffer zone shall beset by the permitting authorities, but not less than 9 m in width, adjacent to the heritage building or area, must be kept absolutely free of any structure or establishment surrounding the heritage building or its part thereof.

3.8.2.6 In general, authority having jurisdiction for planning and development, shall guide the height of any proposed buildings within the protected zone, depending upon the historic and architectural value of the building or area.

3.8.2.7 To protect the monument against human impact, movement of visitors within the structure and site shall be controlled. Climbing over the fabric of the monument shall be illegal and be prevented at all times.

3.8.2.8 Signage shall be installed within the site and building premises to guide visitors by creating circumambulatory path or circulation area around each of the heritage buildings/monuments.

3.8.3 Original Elements

3.8.3.1 Structures that impinge directly on the monument/s, identified to be additions, alterations or extensions of any form or kind on to the original monument/s, shall be removed/relocated elsewhere, in an attempt to recognize the original form/feature of the monument.

3.8.3.2 All original structures and architectural elements are to be retained and restored.

3.8.3.3 In the event that such elements have to be repaired, their features are to be retained intact.

3.8.4 Land Use, Building Height, Setback and Ground Coverage in the Listed Zone

3.8.4.1 For area conservation, to retain the urban fabric of the area, the height, setback and ground coverage for any new development within the listed zone shall comply with the height, setback and ground coverage of the heritage buildings or area to be conserved.

3.8.4.2 For all new developments in area conservation and for the conservation of any listed building or monument the guidelines of Sec 1.17 of Chapter 1 Part 3 shall be applicable.

3.8.5 Upgrading and Adaptive Reuse

3.8.5.1 Adaptive reuse shall follow logical consequence considering public requirements of the region, tourist influx and socio-cultural context of the region under influence.

3.8.5.2 The decision of including different functions shall be made only after thorough investigation by a committee working under the guideline of experts in archaeology and architecture of the region.

3.9 Incentives to Private Owners Affected by Conservation

3.9.1 Listed historic buildings, sites and areas are usually under huge pressure from competing economic activities, and hence are giving rise to sharp land values. Thus listed properties become easy target for demolition or replacement by more use-intensive and denser and taller structures, with apparently better economic return. Hence to safeguard those threaten landowner, special financial incentive should be offered to the stakeholders to preserve our national and universal outstanding values. Considering them as affected people, Transfer of Development Right's (TDR) certificate shall be introduced to protect these heritages.

3.9.2 Transfer of Development Rights (TDR) is a market-based mechanism that promotes responsible growth, while conserving culturally and environmentally sensitive sites and areas. Transfer of Development Rights (TDR) means making available certain amount of additional built up area in lieu of the area relinquished or surrendered by the owner of the land, so that he can use extra built up area either himself or transfer it to another in need of the extra built up area for an agreed value. It is designed to steer growth not to limit or stop development.

3.9.3 Local Governments may use TDR to direct development in specific zones. They may use this tool to preserve heritage areas etc. by allowing its owners to give up their rights to develop these spaces commercially in lieu of TDR. The affected land owner gets the benefit as private sector funds are used to purchase the development rights and build more in areas as per permission of the authority. The Government also gets the benefit by avoiding large public expenditures to protect historically and environmentally sensitive areas and development occurs in suitable areas, resulting in more efficient public services.

3.9.4 In implementing TDR, a Development Rights Certificate (DRC) is a certificate shall be issued by the Authority having jurisdiction to the affected owner of a property, when such property gets listed for conservation or gets affected by falling within the protected zone as mentioned in Sec 3.8.4 where his/her property (either partly or wholly) is reserved for the purpose of public utilities or conservation.

3.9.5 The DRC certificate shall state clearly the following issues-

- (a) The extra FAR (Floor Area Ratio) credit in square meter of the built-up area and the occupancy type to which the owner or lessee of the listed site/plot or affected site/plot is entitled,
- (b) The place and user zone in which the development rights are earned, and
- (c) The areas or zones in which they may be utilized.

3.9.6 To control the unplanned density, this TDR should be used only in the planned non-residential plots developed by the Government. The property owner may use DRC for himself or transfer to any other person.

Chapter 1 Scope And General

1.1 Purpose and Scope

1.1.1 The purpose of this part of the Code is to provide minimum standards to safeguard life, health, property and public welfare by regulating and controlling the design, location, construction and maintenance of signs and outdoor display structures. The requirements of the Code cover the spatial, structural and fire safety aspects of signs located on, within or outside the building. Official traffic signs erected on roads and highways are not covered by this Code.

1.1.2 The unrestrained placement of advertising signs mars the landscape with hoardings and advertising signs within the cityscape as well as in rural areas. Therefore, all signs and billboards shall be liable to take permit as per guidelines of Sec 1.4 of this Chapter and shall also comply with the guidelines of Chapter 3 Part 10 (see Sections 3.10 to 3.11).

1.1.3 The regulations of this Code are not intended, and shall not be understood to permit violation of the provisions of other ordinances, regulations or official requirements in force at or near railway stations, roads, railways, terminals or other places controlled by public agencies having jurisdiction to formulate such regulations.

1.1.4 No sign shall be erected in a manner that would confuse or obstruct the view or interfere with official signs, signals or devices installed for the purpose of guiding or controlling road, rail, marine or air traffic.

1.2 Terminology

This section provides an alphabetical list of the terms used in and applicable to this part of the Code. In case of any conflict or contradiction between a definition given in this Section and that in Part 1, the meaning specified in this part shall govern for interpretation of the provisions of this Part.

ADVERTISING SIGN	Any surface or structure with characters, letters or illustrations applied thereto and displayed in any manner whatsoever out of doors for purposes of advertising or to give information regarding or to attract the public to any place, person, public performance, article or merchandise whatsoever, and which surface or structure is attached to, forms part of or is connected with any building, or is fixed to a tree or to the ground or to any pole, screen, fence or hoarding or displayed in space.
---------------------	---

ALLEY	Public way having width between 2.5 m and 4 m that has been dedicated to public use.
APPROVED PLASTIC	Plastic materials conforming to the requirement of Sec 2.2.5
DIRECTION SIGN	Usually included with an arrow and used for indicating a change in route or confirmation to a correct direction.
DISPLAY SURFACE	The area used to display the advertising message in a sign structure.
IDENTIFICATION SIGN	A sign that gives specific location information identifies specific items, for example, Parking Lot B, Building No. 5, First Aid, etc.
ILLUMINATED SIGN	The display of signs, permanent or otherwise, functions of which depend upon its being illuminated by direct or indirect light, and other than an electric sign.
INFORMATIONAL SIGN	Used for overall information for general organization of a series of elements that is, campus plan, bus route, building layout, shopping mall plan, etc.
MARQUEE	A roofed structure attached to and supported by a building and projecting beyond building line or property line.
NONCOMBUSTIBLE MATERIAL	A material no part of which ignites or burns when subject to fire. Any material conforming to ASTM E136 shall be considered noncombustible.
PUBLIC PASSAGE	A public way having a width less than 2.5 m.
PUBLIC PROPERTY	The land property which has been dedicated or deeded to the public for use.
REGULATORY SIGN	Sign that gives operational requirements, restrictions or gives warnings, usually used for traffic delineation or control, for example 'stop', 'No parking', 'one Way', etc.

1.3 Classification of Signs

For the purpose of this Code, and the regulations and provisions thereof, outdoor displays shall be classified into one of the following types of sign.

BALCONY SIGN	An advertising sign attached to, hung from or posted on a balcony or verandah of a building.
COMBINATION SIGN	An outdoor sign incorporating any combination of features of other signs.
ELECTRIC SIGN	An outdoor advertising display sign, usually animated, wired for lights or luminous tubing and containing other electric fittings, excluding those illuminated by external light source. They shall meet the requirements of the provisions of this Code governing ground, roof, wall, projecting, marquee or other sign as set forth below, depending upon where the electric signs are built.
FIN SIGN	An outdoor sign affixed to the wall or exterior surface of a building with the plane of the sign perpendicular to or at an angle with the building surface projecting more than 300 mm from the surface, the property line or the building line.
GROUND SIGN	An outdoor advertising display sign painted or otherwise displayed on the ground, supported by a pole or a structure erected independently on the ground, or mounted on a vehicle or mobile structure.
MARQUEE SIGN	A projecting sign attached to or hung from a marquee canopy or covered structure projecting from and supported by a building and extending beyond the building line or property line.
PROJECTING SIGN	An outdoor sign other than a wall sign affixed to the wall or exterior surface of a building, with the exposed face of sign in a plane parallel to the wall surface projecting more than 300 mm from the building surface, building line or property line.
ROOF SIGN	An outdoor sign painted on the roof surface or erected upon or above a roof or parapet of a building.
TEMPORARY SIGN	Any sign, banner, pendant or other display constructed of cloth, canvas, fabric, cardboard, bamboo or other light material, with or without a structural frame, intended to be displayed for a limited period only. They shall include signs on gas filled balloons afloat in the air, free or anchored to the ground or a structure, signs or words traced by smoke emitted by flying aircraft or a stationary source and signs tied to a flying aircraft.
WALL SIGN	An outdoor sign directly painted on or pasted or attached to or erected against the wall or exterior surface of a building, projecting not more than 300 mm from the wall.

1.4 Application and Permit

1.4.1 Requirement of Permit

No sign shall be erected, re-erected, constructed, altered or maintained except as provided by this Code. A written permit shall be obtained from the Authority for all signs except those exempted from such permit in Sec 1.4.2.

1.4.2 Exemptions

Signs or alterations of signs described in this section and its subsections shall be exempted from the requirement of a permit. These exemptions shall not be construed as relieving the owner of the sign from the responsibility of ensuring compliance with the provisions of this Code or other regulations or laws pertaining to signs. The following works may be undertaken on existing signs without a permit:

- (a) Changing of the advertisement copy or message on a painted or printed sign only. Except for cinema or theatre marquee signs or similar signs specifically designed for replaceable copy, electric signs shall not be included in this exemption.
- (b) Cleaning, painting or repainting of a sign or sign structure not involving any structural alteration.

The following signs may be erected without a written permit :

- (a) Signs, the top of which is less than 2 m above grade.
- (b) Signs exhibited within the window of a building provided they do not affect the light and ventilation of the building.
- (c) Signs relating to the trade or business carried on within the premises on which such signs are displayed or notices of meeting or sale etc. to be held within the premises.
- (d) Signs painted or pasted on buses or other public transport vehicles provided that no part of such signs projects beyond the body of the vehicle⁶ or obstructs the visibility of the driver or passengers to endanger safe ride.

No permission shall be required for signs covered by the provisions of Sections 1.4.2.1 to 1.4.2.4.

1.4.2.1 Wall Signs: Wall signs listed below shall not require a permit:

- (a) Shop Signs: Signs erected over a display window or entrance of a shop or business establishment which announce the name of the shop and the business carried on provided such signs are less than 1 m in height.

- (b) Building Names: Wall signs erected on public or private buildings which announce the name of the establishment and the nature of occupancy.
- (c) Name Plates: Any wall sign less than 0.5 m² in area announcing the name and identity of the occupier.
- (d) Boundary Signs: Any wall sign less than 0.5 m² in area erected on boundary walls or fences surrounding the premises, or on other ornamental fences, announcing the identity of the premises.

1.4.2.2 Ground Signs Erected on or Visible from Highways: Ground signs erected on or visible from the highways bearing warning, cautionary, informative, identifying and temporary advertising messages of the following description shall not require a permit. When placed on highways these ground signs shall conform to the requirements of Sec 1.6.3.

- (a) Official warning signs, traffic directions and notices displayed on the highway by public authorities or by the requirement of a judicial order.

Example: FERRY AHEAD

- (b) Direction indicators to places of public service.

Examples: POLICE STATION PETROL PUMP

- (c) Signs bearing names of places

Example: SHERPUR TOWN

- (d) Defense warning signs.

Example: SHOOTING RANGE

- (e) Private warning signs not more than 0.2 m² in area.

Example: PRIVATE ROAD

- (f) Signs not more than 0.2 m² in area placed sufficiently clear of the carriageway showing direction to a private property.
- (g) Signs bearing identification, direction or warning messages with respect to the premises on which they are displayed, not exceeding 0.2 m² in area.

Example: MIND THE STEP

- (h) Advertising signs relating to businesses, trades or professions carried out in the buildings on which they are displayed, limited to one sign not exceeding 0.3 m² in area for each business, trade or profession.
- (i) Identification signs relating to educational, medical, social, religious, cultural, recreational or similar institutions, hotels, blocks of flats, hostels, rest houses etc. situated on the premises on which such signs are displayed, limited to one sign not exceeding 1.2 m² in area for each such institution.

- (j) Temporary advertisements relating to the sale or rent of the premises on which they are displayed, limited to one sign not exceeding 2 m² in area for each sale or rent.
- (k) Advertisements announcing sale of goods or livestock, limited to one sign not exceeding 1.2 m² in area, displayed on the land or premises where such sale is held or goods or livestock are situated.
- (l) Advertisements relating to construction works in progress on the land on which the sign is displayed not exceeding 2 m² in area.
- (m) Signs announcing noncommercial local events of a religious, cultural, recreational or educational character, limited to a total of 0.6 m² of display on any premises on which such events are to take place.

1.4.2.3 Temporary Signs: Temporary signs of the following character shall not require a permit :

- (a) Construction site signs displaying the owner or builder's identity or the project description.
- (b) Special and decorative displays used for festivities, fairs, circuses, public demonstrations or promotion of civic welfare and charitable activities, provided such displays do not involve the use of electricity.

1.4.2.4 Other Displays: Signs displayed on the concerned premises meeting the general requirements of Table 10.1.1 and conforming to the other requirements of this Code shall not require a permit.

1.4.3 Application for Permit

Application for a sign permit shall be made in writing by the erector of the sign and the owner/lessee of the premises or site where the sign is to be erected on prescribed form (Appendix A). The application shall be accompanied by the following information:

- (a) Full specification of the sign in a sketch showing the length, height and weight of the sign, and, where applicable, number and disposition of electric lights and fittings and wiring diagram.
- (b) A location plan showing the position of the sign on the site, an elevation showing the sign in relation to the facade and detail drawing of the sign.
- (c) Detail drawings of the sign structure indicating the size of all members and the foundation and, if required by the Authority, design calculations of the structure.
- (d) Any other information as may be required by the Authority.
- (e) Required fee as may be decided by the Authority from time to time.

1.4.4 Condition for Grant of Permit

The grant of permit or license to erect signs shall be subject to the following conditions:

- (a) An application for the grant of permit shall be made to the Authority in the manner prescribed in this Code.
- (b) The applicants must possess right over the property, building or premises upon which the sign is proposed to be erected either by way of ownership or by lease.
- (c) The permission shall be granted at any one time for a period not exceeding three years, on expiry of which the Authority shall have the right to have the sign removed at the erector's expense unless a renewal of the permit has been obtained.
- (d) A permit shall be renewed only upon continued satisfaction of all the conditions under which the original permit was issued.
- (e) The permission or the renewal of permission granted by the Authority shall become void, if
 - any addition or alteration is made to the sign structure except as may be directed by the Authority to make it secure;
 - any change is made in the sign or part thereof, involving a change in the type of sign;
 - any addition or alteration is made to the building which supports the sign involving disturbance of the sign or any part thereof;
 - the sign or any part thereof falls due to accident or other causes; or
 - the building or structure supporting the sign is demolished or destroyed or declared 'unsafe building' by the concerned authority.
- (f) The Authority may, in the interest of the public, suspend the license before expiry of the period in which case the licensee shall remove the sign forthwith.
- (g) The licensee shall maintain the sign and the building or structure supporting or occupied by the sign in safe, neat and sanitary condition.
- (h) The sign shall not, in the opinion of the Authority, mar the aesthetic beauty of the locality.
- (i) No sign other than that pertaining to the building concerned shall be allowed to obstruct or obscure buildings such as hospitals, public offices, educational institutions, places of worship, museums and buildings of national and historic importance.

- (j) No sign or hoarding shall be allowed to obstruct light and ventilation of buildings situated near it.
- (k) No sign shall bear any objectionable, unlawful or obscene display.
- (l) Any hoarding or sign erected on the highways shall also require the express permission of the authority or agency in charge of the highway.
- (m) In addition, all signs shall at all times conform to the requirements given in this Code.

1.4.5 Sanction or Refusal of Permit

Upon receipt of an application for permit the Authority may sanction, sanction with modification or refuse such a permit. The decision of the Authority shall be communicated within 30 days of the date of receipt of all information desired by them, failing which the permit shall be deemed to have been sanctioned. The Authority may withdraw a permit at any time in the interest of public safety and welfare.

Table 10.1.1: Signs Displayed on Concerned Premises which shall not Require a Permit (Sec1.4.2.4)

Description	Example	Number Permitted	Dimensional Limits	Maximum Size of Letters, Symbols etc.	Maximum Height Above Grade to Top of Sign	Electrification Restriction	Other Special Requirements
Identification signs of public undertakings	FIRE BRIGADE PATHOLOGY	As required	As required	As required	As required	As required	
Warnings, direction or identification of utilities	NO PARKING	No limit	Maximum area 4 m ²	800 mm (400 mm in restricted sign zone*)	6 m (5 m in restricted sign zone)	Only for medical services and to indicate danger	
Identification of company, trade, business, profession or person	ABCD & CO.	One at each entrance	Maximum area 0.3 m ² each	800 mm (400 mm in restricted sign zone*)	6 m (5 m in restricted sign zone)	Only for medical services and to indicate danger	
Name of building or premises	CENTRAL LAW ACADEMY	One on each entrance	Maximum area 1.2 m ² each	800 mm (400 mm in restricted sign zone*)	6 m (5 m in restricted sign zone)	Only for medical services and to indicate danger	

Description	Example	Number Permitted	Dimensional Limits	Maximum Size of Letters, Symbols etc.	Maximum Height Above Grade to Top of Sign	Electrification Restriction	Other Special Requirements
Temporary signs relating to sale or letting of property on which displayed	<div style="border: 1px solid black; padding: 2px; width: fit-content; margin: 5px auto;">FOR SALE</div> <div style="border: 1px solid black; padding: 2px; width: fit-content; margin: 5px auto;">TO LET</div>	No restriction but total area not to exceed 2.4 m ²	Width to depth ratio 2:1, total area of all signs not to exceed 2.4 m ²	800 mm (400 mm in restricted sign zone*)	6 m (5 m in restricted sign zone)	No electrification permitted	Shall not be displayed earlier than 1 month prior to date the sale or letting is due and shall be removed within 2 weeks after conclusion of sale or letting.
Construction site signs	SHOPPING CENTRE Consultant Contractor	One for each frontage for each contractor	Maximum area 4 m ²	800 mm (400 mm in restricted sign zone*)	6 m (5 m in restricted sign zone)	No electrification permitted	Permitted only while the construction is in progress
Temporary signs announcing events displayed on the premises where these take place	<div style="border: 1px solid black; padding: 2px; width: fit-content; margin: 5px auto;">INTERNATIONAL BOOK FAIR</div>	No restriction but total area not to exceed 4 m ²	Maximum aggregate area 4 m ²	800 mm (400 mm in restricted sign zone*)	6 m (5 m in restricted sign zone)	Electrification shall require permission	Shall not be displayed earlier than 1 month prior to the start of event and shall be removed within 2 weeks of end of event
Identifying and advertising signs on business premises in restricted sign zone	<div style="border: 1px solid black; padding: 2px; width: fit-content; margin: 5px auto;">XYZ BANK LTD.</div> <div style="border: 1px solid black; padding: 2px; width: fit-content; margin: 5px auto;">ABC TRAVEL</div>	No restriction but total area not to exceed 10% of area of face	Maximum aggregate area not to exceed 10% of area of face	400 mm	5 m	Electrification shall require permission except for medical services and to indicate danger	

1.4.6 Application for Alteration of Sign

A fresh application for permit shall be made each time the ownership of the sign changes or any change in type or structure of the sign is proposed.

1.4.7 Existing Signs

Signs in existence on the date of promulgation of this Code, that would otherwise require a permit, shall be exempted from the requirement of permit for a period of two years after the promulgation of the Code. On expiry of this period these signs shall require a permit as for a new sign.

1.5 Unsafe and Unlawful Signs**1.5.1 Responsibility of the Owner**

It shall be the responsibility of the owner to ensure the safety and legality of the sign irrespective of any reference from the Authority.

1.5.2 Notice of the Authority

If any sign is unlawfully installed or maintained violating any of the provisions of the Code, or if any sign becomes insecure or unsafe, the owner of the sign shall, upon written notice of the Authority, make the sign conform to the provisions of the Code or remove it, within a time period specified by the Authority which shall in no case exceed three days. If the owner fails to comply within the specified time, the Authority shall remove the sign and charge the expenses to the owner.

1.5.3 Prohibited Signs

Any sign which in the opinion of the Authority, fits any of the following descriptions, shall not be permitted under any circumstance:

- (a) Signs of obscene, repulsive, vulgar, revolting or otherwise objectionable character,
- (b) Signs displaying messages prejudicial or subversive to state discipline,
- (c) Signs producing pernicious or injurious effect on a class of persons or the public,
- (d) Signs that disfigure any neighbourhood or destroy its sanctity, or
- (e) Signs those are likely to affect the sentiment of public.

1.6 Restrictions**1.6.1 Restricted Sign Zone**

1.6.1.1 The Authority may, in the interest of aesthetics, moral values or public welfare, designate an area as a restricted sign zone. Kindergartens, elementary schools, primary schools and secondary schools, Parks, playgrounds, places of historical interest, places of architectural heritage, important national monuments, animal and bird sanctuaries, nature reserves etc. may also be designated as restricted sign zones.

1.6.1.2 The erection or display of signs within the restricted sign zone shall be prohibited or restricted in any manner deemed necessary by the Authority.

1.6.1.3 The wording on any sign in the restricted sign zone shall be limited to messages for identification of, direction to and information about the owner of the premises, the nature of business carried on within the premises and location of utilities and services.

1.6.1.4 The restriction on signs in a restricted sign zone shall apply within a distance of 30 m outside the zone.

1.6.2 Prohibition of Advertisement

The erection of any advertising sign shall be prohibited on a site, when in the opinion of the Authority:

- (a) the site is unsuitable for display of advertising signs by virtue of the historic, cultural, architectural or similar characteristics of the locality, or
- (b) the display of an advertising sign is likely to pose a hazard for any form of transport.

1.6.3 Signs on Highways and Roads

Any advertising sign at or near highways or roads shall conform to the following requirements in addition to the requirements of the respective authority.

- (a) No sign shall obscure or otherwise hinder interpretation of official traffic signs.
- (b) Signs on the sides of over-bridges or flyovers across the carriageway shall not project beyond any edge of the parapet of the over-bridge or flyover.
- (c) No sign shall be erected within the right of way of the road nor within 10 m of the edge of the carriageway. The size of the sign erected at 10 m away from the edge of the carriageway shall not be more than 3 m². This limit on size shall be increased by 0.3 m² for each extra meter of setback from the edge of the carriageway.
- (d) No sign shall be erected in such manner or at such places as to obstruct or interfere with the visibility of approaching, intersecting or merging traffic.
- (e) No sign shall be erected within 100 m of a bridge, railway level crossing or road junction. For urban roads this distance may be reduced to 50 m.
- (f) No sign shall be erected in such a way as to hinder visibility at pedestrian crossings.

1.6.4 Illuminated Displays

The following illuminated advertisements that threaten traffic safety shall not be permitted:

- (a) Illuminated or electric advertisements of such brilliance or intensity as to produce glare and impair vision of the driver and the pedestrians;
- (b) Advertisements containing flashing or intermittent lights of intense brightness;
- (c) Advertisements containing lights of such colour, disposition, brightness, movement or flashes as to obscure or reduce effectiveness of official traffic lights, signals, signs or devices.

1.7 Maintenance and Inspections

1.7.1 Maintenance

Signs and their supporting structures, together with the supports, braces, guys and anchors shall be maintained in sound condition and any deterioration shall be repaired immediately. All non-galvanized and corrosion susceptible metal components shall be painted at least once in every two years. The Authority may order removal of signs which are not maintained in proper order and such removal shall be at the owner's expense.

1.7.2 Inspection

Every sign shall be subject to inspection by the Authority from time to time as required by the Authority. The owner of the sign shall ensure access of the inspector and facilitate the inspection.

1.8 Location Restrictions

1.8.1 An outdoor display sign shall not be erected, constructed or maintained so as to obstruct any fire escape or any window or door or opening used as a means of egress or so as to prevent free passage from one part of a roof to the other.

1.8.2 A sign shall not be attached in any form, shape or manner to a fire escape, nor be placed in such manner as to interfere with openings required for lighting and ventilation.

1.9 Projection Over Public Property

1.9.1 No part of a sign or sign structure shall project into a private property not owned or leased by the owner/erector of the sign, unless explicit agreement has been entered into with the owner of that property.

1.9.2 Signs and sign structures shall project neither into public property nor into roads wider than 4 m, below a height of 2.5 m above grade, nor project more than 0.3 m when the sign is erected 2.5 m above finished grade. The signs may project 0.3 m plus 0.12 m for each 0.25 m of clearance above 2.5 m when the height is between 2.5 m and 5 m above grade. Signs may not project more than 1.5 m into a public property under any circumstance.

1.9.3 No sign or part thereof shall project into public passages. Projection of signs and sign structures over public alleys shall be limited to the values provided in Table 10.1.

Table 10.1.2: Projection of Signs over Public Alleys

Height Above Finished Grade (m)	Maximum Projection (m)
Less than 4	No projection permitted
4 to 5	0.3
over 5	0.6

1.10 CLEARANCE FROM POWER LINES

All signs and sign structures shall maintain the clearances from overhead electrical conductors as specified in Table 10.1.3

Table 10.1.3: Clearance from Power Lines

Voltage of the Line	Vertical distance (m)	Horizontal Distance (m)
Low and Medium Volt	2.5	1.25
33 KV	3.5	1.75
Over 33 KV	3.5 Plus 0.3 m for each additional 33 KV or part thereof	1.75 Plus 0.3 m for each additional 33 KV or Part thereof

1.11 Related Appendix

Appendix A Application for Permit to Erect or Alter Outdoor Signs

Chapter 2 General Requirements

2.1 Design

2.1.1 Loads

All outdoor signs and sign structures shall be designed to resist wind, gust during storm, seismic and other forces as specified in Chapter 2: Loads, Part 6 of this Code. Combination of wind and seismic loads shall not be required. Loading that produces higher stresses shall be used.

2.1.2 Design Consideration

All outdoor signs and sign structures shall be designed fulfilling the design requirements as set out in Chapter 1: General Design Requirements: Structural Design, Part 6 of this Code.

2.2 Construction

All outdoor signs and sign structures shall be constructed and erected in accordance with the requirements of Chapter 1: Constructional Responsibilities and Practices, Part 7 of this Code.

2.1.2 Use of Materials

All materials for outdoor signs and sign structures shall conform to the specification as set out in Part 5: Building Materials of this Code.

2.2.2 Use of Combustible Materials

Ground signs not higher than 6 m may be constructed of any material that meets the requirements of this Code. No combustible material other than approved plastic as defined in Sec 2.2.5, shall be used in the construction of electric signs. Roof, wall, projecting, fin, balcony, marquee and combination signs shall be constructed of noncombustible materials except as provided below:

- (a) On roofs of combustible construction, the roof sign may be constructed of combustible materials.
- (b) On roofs of any type of construction, roof signs not higher than 1.5 m and not exceeding 5 m² in area may be constructed of combustible materials.
- (c) On walls of combustible construction, wall signs not involving the use of electricity may be constructed of combustible materials.

2.2.3 Anchorage

Foundation for all unbraced signs shall be designed to resist horizontal, vertical and overturning forces. All braced ground signs shall be anchored to resist the specified wind and seismic forces in any direction. Anchors shall be designed for safe soil bearing capacity and for an effective uplift force which is 25% more than the force required to resist overturning. Anchorage of signs shall not be connected to an unbraced parapet wall unless the wall is designed for seismic load.

2.2.4 Display Surfaces

Display surfaces of outdoor signs may be made of metal, glass or approved plastic. If the surface of the sign is made of glass, the thickness and area shall be as set forth in Table 10.2.1.

Table 10.2.1: Type, Size and Thickness of Glass Panels Used in Signs

Maximum Size of Glass Panel		Minimum Thickness (mm)	Type of Glass
Any dimension (m)	Area (m ²)		
0.75	0.30	3	Plain, Plate or Wired
1.15	0.45	5	Plain, Plate or Wired
3.65	2.30	6	Plain, Plate or Wired
above 3.65	above 2.30	6	Wired Glass

Plastic of approved type may be used for wall signs in sections not exceeding 20 m² in area. Plastics sections on wall signs shall be separated 1 m laterally and 2 m vertically. Approved plastics of unlimited area may be used on any sign other than wall sign, if approved by the Authority

2.2.5 Approved Plastics

Plastic materials which burn at a rate no faster than 65 mm per minute when tested in accordance with ASTM D 635 shall be deemed approved plastic. Only approved plastic shall be used for plastic display surfaces provided for in Sec 2.2.4 above. Approved plastics may also be used for ornamental purposes, decorations, lettering, facings etc. on signs and outdoor display structures.

2.2.6 Draining Arrangements

Signs constructed on ground or at places where possibility of accumulation of water exists shall have adequate provision for proper drainage.

2.3 Use of Glass In Signs

Glass when used in outdoor signs shall be at least 3 mm thick and shall conform to the requirements of Sec 2.16.14: Glass and Glazing, of Part 5 of this Code. The area of each glass panel shall not exceed 6 m² and shall be securely fixed with the frame independently. Appropriate protection against damage by falling objects shall be provided to all glass panels by metal canopies or other approved means. Use of glass may be discouraged or avoided wherever possible for signs placed overhead. For such uses, if permitted, the authority may impose condition of using 'tempered glass' so as to produce no sharp edges or large pieces if broken accidentally.

2.4 Servicing Devices

All servicing devices (ladders, platforms, hooks, rings etc.), used for cleaning, painting, repainting of sign shall have adequate safety devices and shall be of approved type and quality.

2.5 Interference by Signs

Signs shall not be placed at such locations that would obstruct the use of fire hydrants or other firefighting appliances. Signs in bends and curves shall be placed in such a location so as not to obstruct the view of traffic at intersecting streets.

2.6 Hours of Operations

No electric sign or other type of signs using electric power source, other than those necessary in the opinion of the Authority in the interest of public amenity, health and safety, shall be operated between midnight and sunrise.

Chapter 3

Specific Requirements for Various Types of Signs

3.1 Electric Signs

3.1.1 Materials

Materials for the construction of electric signs shall be noncombustible except as provided in Sec 2.2.2

3.1.2 Location

Electric signs in colour erected at a height lower than two stories or 6 m above the pavement shall be provided with suitable screen to avoid confusion with traffic signals. No sign in red, amber or green colours shall be erected within a horizontal distance of 10 m from any traffic signal.

3.1.3 Installation

All electric signs including the electrical equipment in connection with the sign shall be installed in accordance with the provisions of Chapter 1 Part 8 of this Code.

3.1.4 Illumination

Electric signs shall not be of such intense illumination as to cause inconvenience or disturbance to residents of adjacent buildings or to the drivers on road.

3.1.5 Operational Hours

The operational hours of electric signs will be restricted (as referred in Sec 2.6 Chapter 2 of this Part)

3.2 Ground Sign

3.2.1 Material

All ground signs over 6 m in total height shall be constructed of noncombustible materials meeting the requirements of this Code, or of approved plastics as defined in Sec 2.2.5 Chapter 2 of this Part. Materials used for the construction of ground sign supporting structures may be treated timber, masonry, concrete or corrosion resistant metal.

3.2.2 Height

The height of ground signs excluding the lighting reflectors shall be limited to 9 m.

3.2.3 Design

The design and construction of ground signs shall conform to the requirements of Part 6 and Part 7 of this Code. All ground signs shall have a firm support and shall be anchored to the ground.

3.2.4 Clearance

All ground signs shall be provided with a clearance height of 0.6 m from the ground. The intervening space may be filled with open lattice work. Under no circumstance shall any ground sign obstruct or interfere with entrance or exit of a building.

3.2.5 Visual Obstruction

All ground signs must be sited in a manner so that they don't pose any visual obstruction to the traffic signs or to any emergency signs (e.g. hospital entry)

3.3 Roof Signs

3.3.1 Material

All roof signs including the frames shall be constructed of noncombustible materials except as provided in Sec 2.2.2 Chapter 2 of this Part.

3.3.2 Design

Design and construction of roof signs shall conform to the requirements of Part 6 and Part 7 of this Code. Roof signs shall be properly secured and anchored to the building and the building shall be designed to avoid overstress due to the sign.

3.3.3 Clearance

Roof signs shall not prevent free passage from one part of the roof to the other. Such passages shall be not less than 1 m wide and 1.25 m high.

3.3.4 Projection

No roof sign shall project beyond the roof in any directions.

3.4 Projecting Signs

3.4.1 Material

All projecting signs and their supporting frames shall be of noncombustible material except as provided in Sec 2.2.2 Chapter 2 of this Part

3.4.2 Design

The supporting frame of projecting signs and the building element to which it is anchored shall be designed to withstand, in addition to dead, live and wind loads calculated in accordance with Part 6 of this Code, appropriate loads due to servicing personnel and equipment.

3.4.3 Height and Clearance

A minimum of 2.5 m clearance from the road surface shall be provided for any projecting sign. The maximum height of a projecting sign shall be 15 m when erected against buildings having a height of more than 8 storey or 36 m. For buildings 5 to 8 stories high but not exceeding 36 m, the height of the projecting signs shall be limited to 12 m. The height of the sign shall be limited to 9 m when attached to a building less than 4 storey or 18 m high.

3.4.4 Projection

Projecting sign or any part of its supporting structures shall not project more than 2 m beyond the building. When such sign faces the street, it shall not project beyond the property line. Projecting sign shall not extend above the eaves of the roof of the building to which it is attached. Projection over public property or alley of projecting signs shall be limited to the values as specified in Sec 1.9 Chapter 1 of this Part.

3.4.5 Attachment

All projecting signs shall be so constructed or attached to the building that movement in any direction is prevented by rods, anchors, brackets, chains etc.

3.4.6 Visual Obstruction

All projection signs must be sited in a manner so that they don't pose any visual obstruction to the traffic signs or to any emergency signs (e.g. hospital entry)

3.5 Fin Signs

3.5.1 Material

Materials for fin sign shall conform to the requirements of Sec 2.2.2 Chapter 2 of this Part.

3.5.2 Design

Design and construction of fin signs shall conform to the requirements of Part 6 and Part 7 of the Code.

3.5.3 Clearance

Fin signs shall not obstruct windows and reduce light and ventilation to such a point as the Code or other regulations prohibit. Such signs and their frames shall not obstruct fire escape, exit and entrance of the building to which they are attached. Projection of fin signs over public property shall conform to the requirements of Sec 1.9 Chapter 1 of this Part.

3.6 Balcony Signs

3.6.1 Materials

Materials for balcony signs shall conform to the requirements of Sec 2.2.2 Chapter 2 of this Part.

3.6.2 Location

Balcony signs shall be placed above eaves of the balcony and shall not project beyond rear of the roof gutter.

3.6.3 Size

The height of a balcony signs shall be limited to 1 m. The hanging balcony sign shall not exceed 2.5 m in length and 50 mm in thickness. For hanging box type signs the maximum allowable depth shall be 200 mm.

3.6.4 Projection

Balcony signs shall not extend beyond the balcony line. Hanging balcony signs shall maintain a clearance height of 2.5 m from the finished ground level. Projection of balcony sign over public property or alley shall be limited to values as specified in Sec 1.9 Chapter 1 of this Part.

3.7 Marquee Signs

3.7.1 Materials

Materials for the construction and erection of marquee signs shall conform to the requirements of Sec 2.2.2 Chapter 2 of this Part.

3.7.2 Size

The height of a marquee sign shall be limited to 2 m. The length of such sign may be equal to the length of the marquee and no projection beyond the full length shall be allowed.

3.7.3 Clearance

A clearance height of at least 2.5 m shall be provided for marquee signs.

3.8 Combination Signs

All combination signs shall meet the general and specific requirements of all the component classes of sign.

3.9 Temporary Signs

3.9.1 Size

The area of a temporary sign shall not ordinarily exceed 10 m². Temporary signs of a larger area may be erected upon explicit approval of the Authority which shall only be granted, for signs of a duration not exceeding 7 days. Temporary signs made of rigid material shall not exceed 3 m² in area, nor shall they have a height more than 2 m. Such rigid signs shall be anchored to the ground or a building by a rigid structure.

3.9.2 Duration

Temporary signs shall be removed from the location within 60 days of first erection, unless explicit permission of the Authority for extending this period has been obtained. In no case a temporary sign shall be permitted to be maintained for more than 90 days.

3.9.3 Support

Temporary signs shall be adequately supported and secured in place. No part of the sign shall be permitted to dangle, sway or otherwise become loose or detached. In order to reduce wind resistance on signs made of fabric, adequate perforations shall be provided.

3.9.4 Location

All temporary signs shall be subject to the approval of the Authority and shall be erected in such a place so as not to obstruct any public way, foot path or entrance and exit of any building.

3.9.5 Projection

Temporary cloth sign may extend over public property. A clearance of 6 m shall be maintained when such signs are placed over a public street. Other temporary signs when placed 2.5 m above the ground may project not more than 300 mm over public property or beyond the legal setback line.

3.10 Additional Guidelines for Signs in Urban and Rural Areas

3.10.1 Erecting, maintaining and owning signs in rural areas shall be encouraged so as to create awareness, dissemination of information and to boost economic status of the rural population.

3.10.2 The tolerance criteria for the permission granted towards putting up any signs for any urban area shall be as given in Sections 3.10.2.1 to 3.10.2.4.

3.10.2.1 Small towns

The traffic hazards in small towns are few and the defacement due to excessive advertising signs has not occurred. Therefore, orderly development of signs may enliven the town environment and boost the economy. The tolerance here may be high.

The following guidelines may be followed for signage :

ADVERTISING SIGN	Electric sign, ground sign, building sign, illuminated sign, sky sign and temporary sign are permissible.
DIRECTIONAL SIGN	Electric sign, ground sign, building sign, illuminated sign and temporary sign are permissible while sky sign is not permissible.
INFORMATIONAL SIGN	Electric sign, ground sign, building sign, illuminated sign and temporary sign are permissible while sky sign is not permissible.
IDENTIFICATION SIGN	Electric sign, ground sign, building sign, illuminated sign and temporary sign are permissible while sky sign is not permissible.
REGULATORY SIGN	Electric sign, ground sign, illuminated sign and temporary sign are permissible while building sign and sky sign are not permissible.

3.10.2.2 Medium (District level) towns

The traffic hazards in medium towns are few and the defacement due to excessive advertising signs has not occurred. Proper design, erection and maintenance of the signs shall be encouraged. The following guidelines may be followed for signage :

ADVERTISING SIGN	Electric sign, ground sign, building sign, illuminated sign, sky sign and temporary sign are permissible.
DIRECTIONAL SIGN	Electric sign, ground sign, illuminated sign are permissible while building sign, sky sign and temporary sign are not permissible.
INFORMATIONAL SIGN	Electric sign, ground sign, illuminated sign, and temporary sign are permissible while building sign and sky sign are not permissible.
IDENTIFICATION SIGN	Electric sign, ground sign, building sign, illuminated sign and temporary sign are permissible while sky sign is not permissible.
REGULATORY SIGN	Electric sign, ground sign, illuminated sign and temporary sign are permissible while building sign and sky sign are not permissible.

3.10.2.3 Large (Divisional level) cities

Accident risks due to density and complexity of traffic in large cities is high. Unplanned advertisements may add more risk to this situation. Defacement of buildings, roads and urban spaces due to advertisements has to be controlled. Therefore, the permissivity and tolerance for erecting signs is very low. The following guidelines may be followed for signage:

ADVERTISING SIGN	Electric sign, ground sign, illuminated sign and sky sign are permissible while building sign and temporary sign are not permissible.
DIRECTIONAL SIGN	Ground sign, illuminated sign are permissible while electric sign, building sign, sky sign and temporary sign are not permissible.
INFORMATIONAL SIGN	Ground sign, illuminated sign, building sign and temporary sign are permissible while electric sign and sky sign are not permissible.
IDENTIFICATION SIGN	Electric sign, ground sign, building sign, illuminated sign and temporary sign are permissible while sky sign is not permissible.
REGULATORY SIGN	Ground sign, illuminated sign and temporary sign are permissible while electric sign, building sign and sky sign are not permissible.

3.10.2.4 Mega and metro cities

The traffic hazards in mega and metro cities are many and the defacement due to excessive advertising signs has marred the urban environment. The density of population is very high and the danger of greater loss of life due to disasters is self-evident. Therefore, the permissivity for erecting signs is very low and no tolerance exists for law breakers. The following guidelines may be followed for signage :

ADVERTISING SIGN	Electric sign, ground sign, illuminated sign and sky sign are permissible while building sign and temporary sign are not permissible.
DIRECTIONAL SIGN	Ground sign, illuminated sign are permissible while electric sign, building sign, sky sign and temporary sign are not permissible.

INFORMATIONAL SIGN	Ground sign, illuminated sign and temporary sign are permissible while electric sign, building sign and sky sign are not permissible.
IDENTIFICATION SIGN	Electric sign, ground sign, building sign, illuminated sign and temporary sign are permissible while sky sign is not permissible.
REGULATORY SIGN	Ground sign, illuminated sign and temporary sign are permissible while electric sign, building sign and sky sign are not permissible.

3.11 Environmental Graphics and Graphics for Universal Accessibility for Cityscape

3.11.1 The urban environment may be susceptible to confusion and chaos due to improper graphics, hoardings and advertisements. Therefore, the signage should be installed following requisite guidelines keeping the functional, safety and aesthetic aspects in view. The scale of the project should also be considered for implementing signage design. In urban design/planning projects and landscape projects on a large scale, the following criteria should be followed for signs and outdoor display structures :

- (a) The aesthetic and harmonious development of the visual environment.
- (b) Signage for the handicapped at all grade changes, entry points to buildings and public conveniences and facilities. Braille strips used should be displayed not above 1.5 m height for the benefit of the visually impaired at all important nodes, entrances and routes, Ramps for the people on wheelchair should be highlighted with the appropriate international sign of the wheelchair. These signs are needed to be lighted adequately even at night time.
- (c) Environmental graphics should be creatively designed to cater to the basic function of information, identity and way finding, with the objective of improvement of urban-scape.
- (d) Safety aspects.
- (e) Protection of trees and other vegetation from harm due to signs.

3.11.2 For People with disabilities or any kind of impairment all signs and symbols shall comply with the guidelines of Sec D.26 of Appendix D of Part 3.

Appendix A**Application for Permit to Erect or Alter Outdoor Signs****Application for Permit to Erect or Alter Outdoor Signs**

1. Type of Sign : _____
2. Location of Sign : _____

3. Details of Sign
 - a) Dimension
 - i) Length _____ m
 - ii) Width _____ m
 - iii) Thickness _____ mm
 - b) Clearance and Projection
 - i) Clearance _____ m
 - ii) Projection _____ m
4. Type of Materials Used
 - i) Noncombustible
 - ii) Approved plastic
 - iii) Combination
5. Details of Electrical Installations (if any) : _____

6. Structural details of signs and supporting structures including foundations : _____

7. This application is accompanied by all required plans, drawings and other details as required by Sec 1.4.3 of this code.

Yes _____ No _____

Signature of owner of
the Building/Premise

Date _____

Name in Full _____

Address _____

Signature of Applicant

Date _____

Name in Full _____

Address _____